

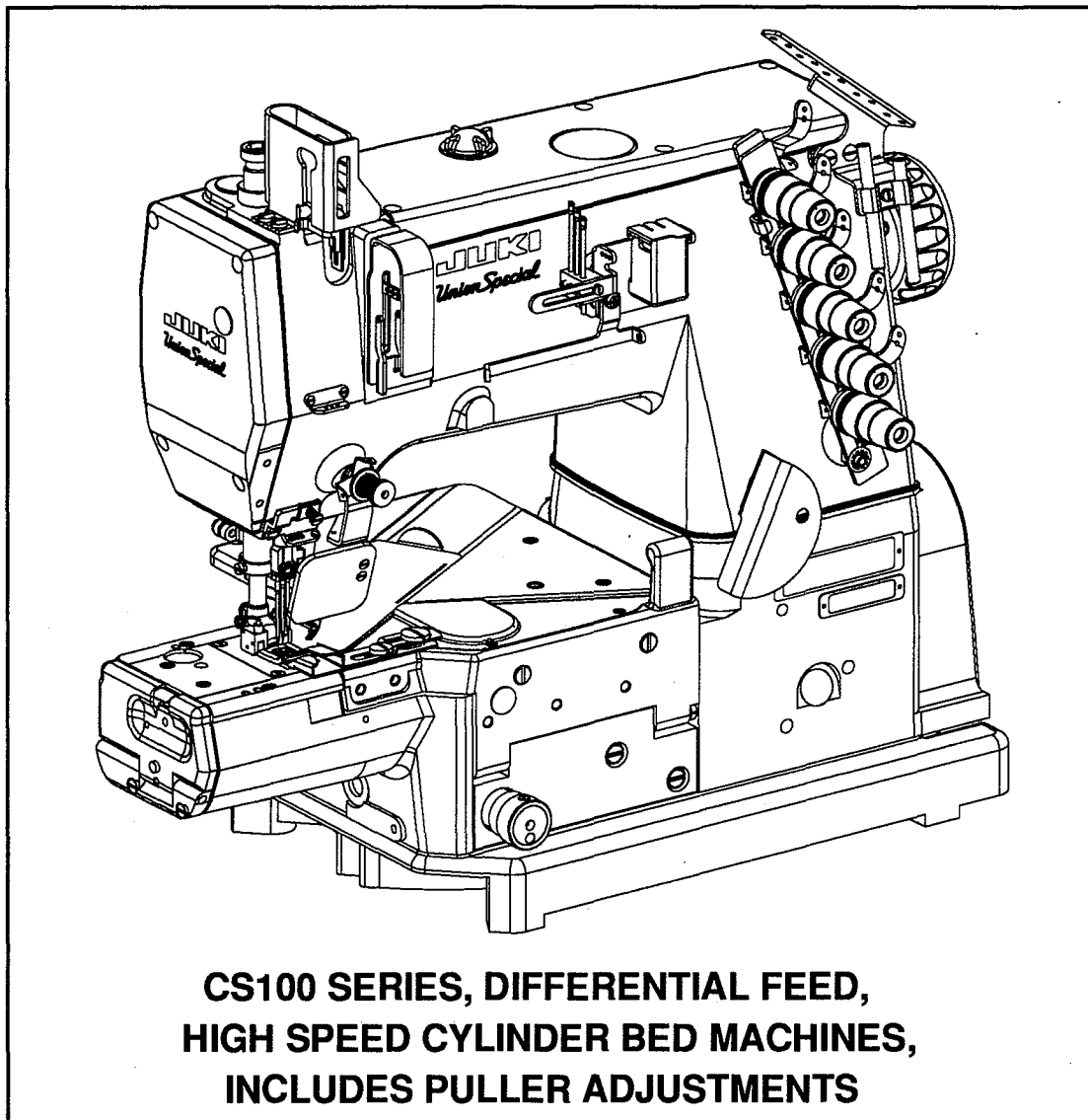

Union Special

INDUSTRIAL SEWING EQUIPMENT

OPERATOR'S MANUAL



CS100 SERIES, DIFFERENTIAL FEED,
HIGH SPEED CYLINDER BED MACHINES,
INCLUDES PULLER ADJUSTMENTS

MANUAL NO. OP9637

STYLES

CS122E11

CS122H21

CS125H11

CS132E11

CS132H21

CS135H11

CS122H01

CS122K01

CS132H01

CS122K02

Manual No. OP9637 Operator's Manual for CS100 Series Machines

Third Edition Copyright 1997

By

Union Special Corporation Rights Reserved In All Countries

Printed in U.S.A. 1997

PREFACE:

This operator's manual has been prepared to guide you while operating the CS100 Series machines. It can be used in conjunction with Union Special Engineer's Manual EN9424 and Parts Manuals PT9425, PT9505, PT9609 depending on application.

This manual explains in detail the proper settings for operation of the machine. Illustrations are used to show the adjustments and reference letters are used to point out specific items discussed.

Careful attention to the instructions and cautions for operating and adjusting these machines will enable you to maintain the superior performance and reliability designed and built into every Union Special machine.

Adjustments and cautions are presented in sequence so that a logical progression is accomplished. Some adjustments performed out of sequence may have an adverse effect on the function of the other related parts.

This manual has been comprised on the basis of available information. Changes in design and/or improvements may incorporate a slight modification of configuration in illustrations or cautions.

On the following pages will be found illustrations and terminology used in describing operating instructions for your machine.

CONTENTS

PREFACE:	2
• IDENTIFICATION OF MACHINES:	3
• STYLES OF MACHINES:	3
• NEEDLES:	3
• SAFETY RULES:	4
• BUILDING BLOCK STYLE DESIGNATION SYSTEM	5
• CAUTION AREAS:	6
• OPERATOR'S DAILY CHECK LIST:	7
• OPERATING CAUTIONS:	7
• OPERATING CAUTIONS (CONT.):	8
• OPERATING THE PEDALS:	8
• LUBRICATION:	9
• LUBRICATION (CONT.):	10
• CLEANING OIL FILTER AND CHAMBER:	10
• INSERTING NEEDLES:	11
• THREADING THE MACHINE:	12
• THREADING THE MACHINE (CONT.):	13
• THREADING THE MACHINE (CONT.):	14
• THREADING METHODS:	14
• PRESSER FOOT PRESSURE AND LIFTER:	14
• ROLLER PRESSURE ADJUSTING KNOB:	15
• ADJUSTING THE STITCH LENGTH:	15
• PULLER STITCH LENGTH:	15
• DIFFERENTIAL FEED MECHANISM:	16
• PULLER LIFTER LEVER:	16
• FOLDER ADJUSTMENTS:	17
NOTES	18
NOTES	19



IDENTIFICATION OF MACHINES:

Each UNION SPECIAL machine is identified by a style number, which is stamped into the style plate affixed to the middle of the machine under the tension assembly. The serial number is stamped into the serial number plate affixed to the right rear base of the machine.

STYLES OF MACHINES:

Precision two or three needle cylinder bed machines with top or bottom coverstitch. Rotary mainshafts for smoother, quieter and faster operations. Equipped with quick change for main and differential feed. Independently driven rear needle guard, no adjustment necessary when changing stitch length. Adjustable looper avoid eccentric to adapt the looper avoid motion and the elliptic path of looper to the required needle size and type of sewing threads.

NEEDLES:

Each needle has both a type and size number. The type number denotes the kind of shank, point, length, groove, finish and other details. The size number, stamped on the needle shank, denotes the largest diameter of the blade measured between the shank and the eye. Collectively, the type number and size number represent the complete symbol which is given on the label of all needles packed and sold by Union Special.

TYPE

DESCRIPTION

121 GJS	Short, double groove, struck groove, regular point, spotted, tapered blade reinforcement, chromium plated - sizes 055/022, 060/024, 065/025, 070/027, 075/029, 080/032, 090/036.
---------	--

When changing the needle, make sure it is fully inserted in the needle head before the screw is tightened.

When ordering needles, please use the complete type and size numbers as printed on the package to ensure prompt and accurate processing of your order. A complete order should read as follows: "100 needles, type 121 GJS, size 070/027".



SAFETY RULES:

1. Before putting the machines described in this manual into service, carefully read the instructions. The starting of each machine is only permitted after taking notice of the instructions and by qualified operators.

IMPORTANT! Before putting the machine into service, also read the safety rules and instructions from the motor supplier.

2. Observe the national safety rules valid for your country.
3. The sewing machines described in this instruction manual are prohibited from being put into service until it has been ascertained that the sewing units which these sewing machines will be built into, have conformed with the EC Council Directives (89/392/EEC, Annex II B).

Each machine is only allowed to be used as foreseen. The foreseen use of the particular machine is described in paragraph "STYLES OF MACHINES" of this instruction manual. Another use, going beyond the description, is not as foreseen.

4. All safety devices must be in position when the machine is ready for work or in operation. Operation of the machine without the appertaining safety devices is prohibited.
5. Wear safety glasses.
6. In case of machine conversions and changes all valid safety rules must be considered. Conversions and changes are made at your own risk.
7. The warning hints in the instructions are marked with one of these two symbols:



8. When doing the following the machine has to be disconnected from the power supply by turning off the main switch or by pulling out the main plug:
 - 8.1 When threading needle(s), looper, spreader etc.
 - 8.2 When replacing any parts such as needle(s), presser foot, throat plate, looper, spreader, feed dog, needle guard, folder, fabric guide etc.
 - 8.3 When leaving the workplace and when the workplace is unattended.
 - 8.4 When doing maintenance work.
 - 8.5 When using clutch motors without actuation lock, wait until the motor is stopped totally.
9. Maintenance, repair and conversion work (see item 8) must be done only by trained technicians or special skilled personnel under consideration of the instructions.
10. Any work on the electrical equipment must be done by an electrician or under direction and supervision of special skilled personnel.
11. Work on parts and equipment under electrical power is not permitted. Permissible exceptions are described in the applicable sections of standard sheet DIN VDE 0105.
12. Before doing maintenance and repair work on the pneumatic equipment, the machine has to be disconnected from the compressed air supply. In case of existing residual air pressure, after disconnecting from compressed air supply (i.e. pneumatic equipment with air tank), the pressure has to be removed by bleeding.

CS100 SERIES

BUILDING BLOCK STYLE DESIGNATION SYSTEM

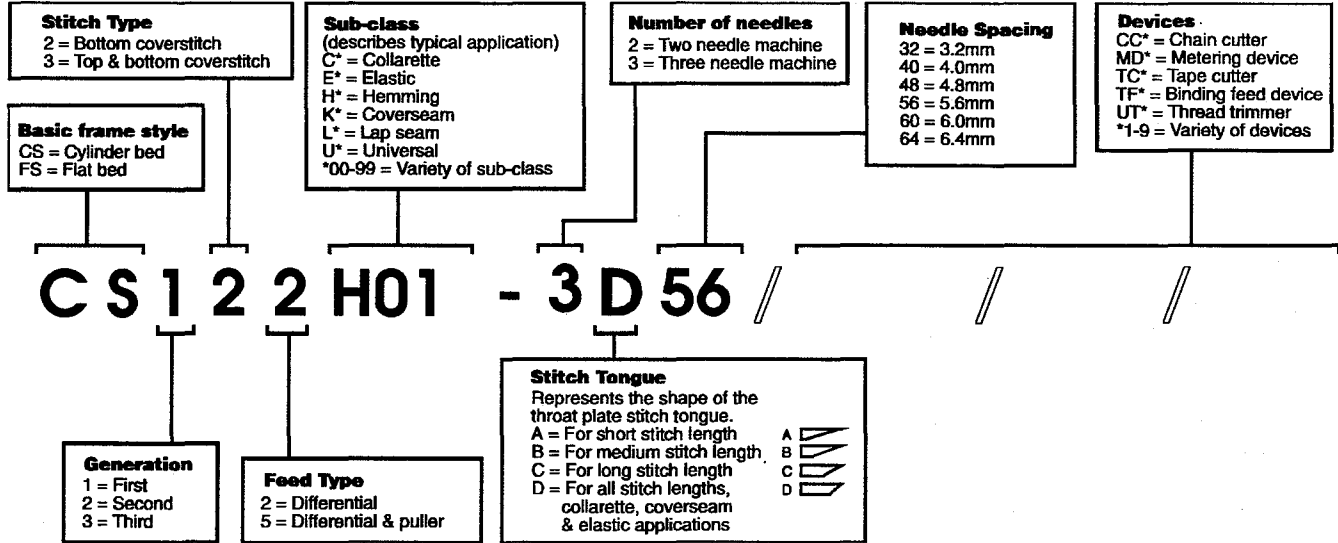

CAUTION AREAS:

CAUTION



WEAR SAFETY GLASSES DO NOT TAMPER WITH SAFETY SHIELD. USE WITHOUT SHIELD MAY CAUSE INJURY.

CAUTION



KEEP NEEDLE BAR GUARD IN PLACE

NEEDLE TYPE 121

CAUTION



KEEP BELT GUARD IN PLACE

CAUTION



KEEP COVER CLOSED DURING OPERATION

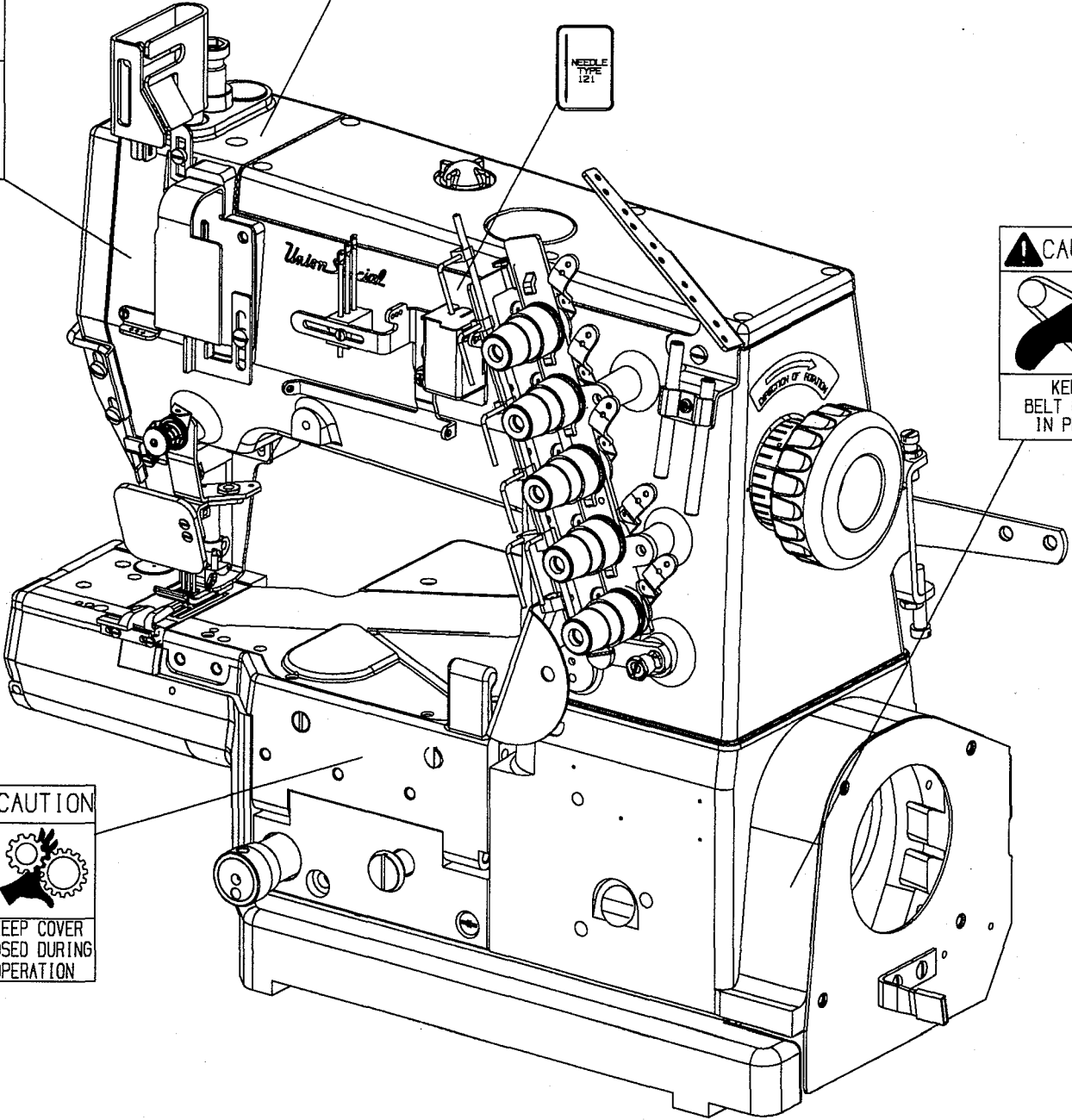

OPERATOR'S DAILY CHECK LIST:

The following should be checked daily and cleaned as required when it applies to your Union Special machine:

- Oil flow
- Oil level
- Lint area (clean with compressed air or brush)
- Looper thread take-up cam area (clean with compressed air or brush)
- Needle bar bushings
- Under feed dogs & throat plates
- In knives
- In thread control eyelets
- Cooling airways
- In the machine
- In the motor
- In the cooling package (package is an extra send charge)

NOTE: Failure to keep sewing parts and feeding area clear of lint may result in oil leakage and soiled garments.

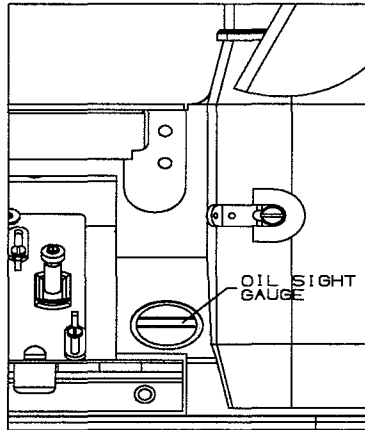

1. The oil level in the sight gauge should be between the two red lines when the machine is at rest. If not, fill with Union Special Specification 175 oil, (Union Special Part No. 28604R).

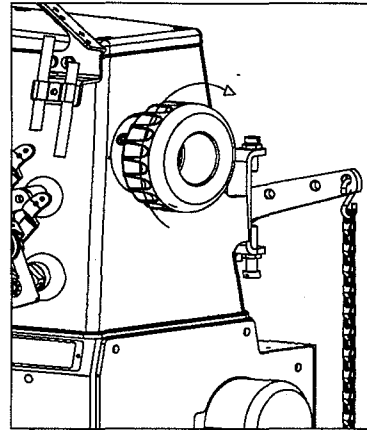

2. The correct rotating direction of the handwheel is clockwise, as viewed from the handwheel's side. NEVER run the machine in reverse direction.

OPERATING CAUTIONS:

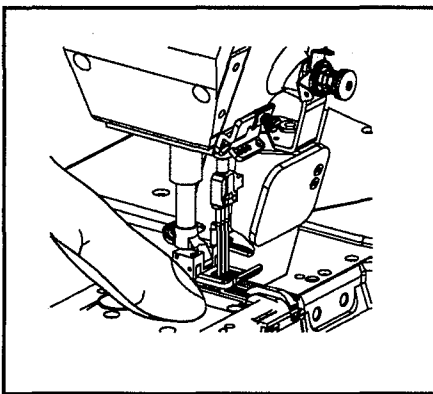

1. Do not put your hand under the needles when turning on the power switch or at any time.

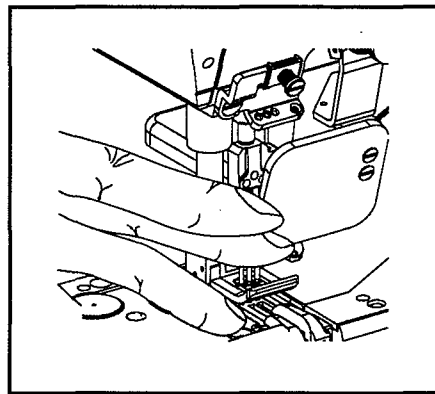

2. Do not put your hand into the sewing area while the machine is running.

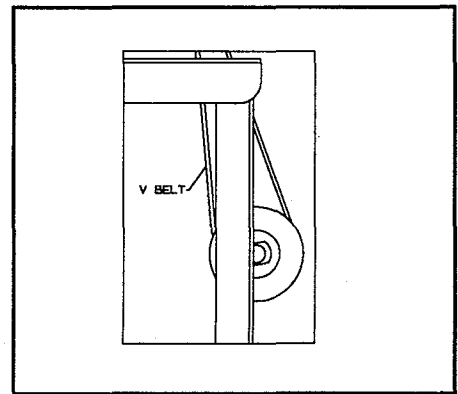

3. Turn off the power switch and make sure the clutch motor is at rest before removing the V belt.

OPERATING CAUTIONS (CONT.):



4. During operation, do not allow head, hands or any instrument, tool etc. near handwheel, V belt and motor.
5. Do not operate your machine without the proper belt guard, sewing guards or any other protectors that have been provided. Doing so is very dangerous.
6. Before inspecting, adjusting, cleaning, threading the head or replacing needles, turn OFF the power switch. Make sure the flywheel on the motor has stopped, it will be kept running by inertia after turning OFF the power switch. DO NOT depress the foot pedal while the motor is running or it will cause the machine to rotate abruptly.
7. Turn OFF the power switch when you leave your machine or in case of a power failure.
8. Do not wipe the machine surface with lacquer thinner.

OPERATING THE PEDALS:

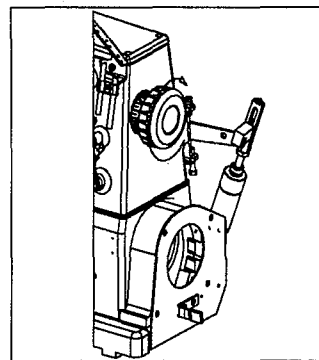
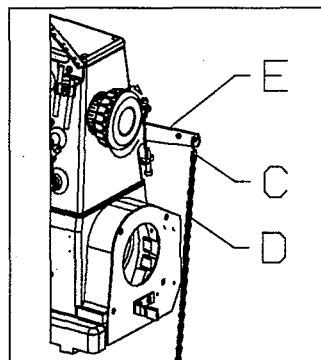
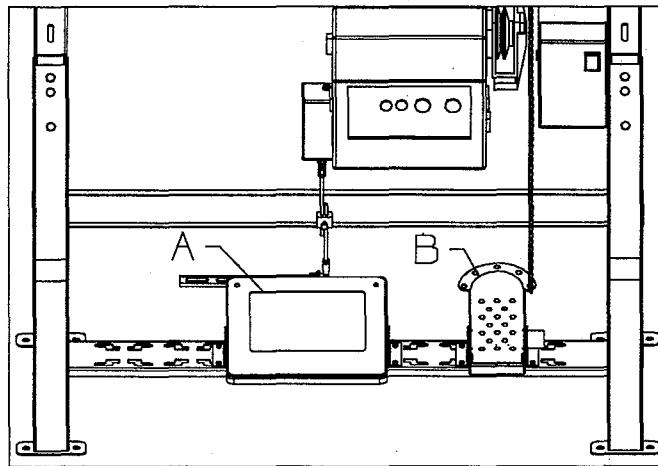

1. Locate the center of drive treadle (A) to be in line with the needles.
2. Locate presser lifter pedal (B) for operator comfort.
3. Use S-shaped hook (C) to connect presser lifter pedal chain (D) to presser lifting lever (E). Depending on application.

LUBRICATION:

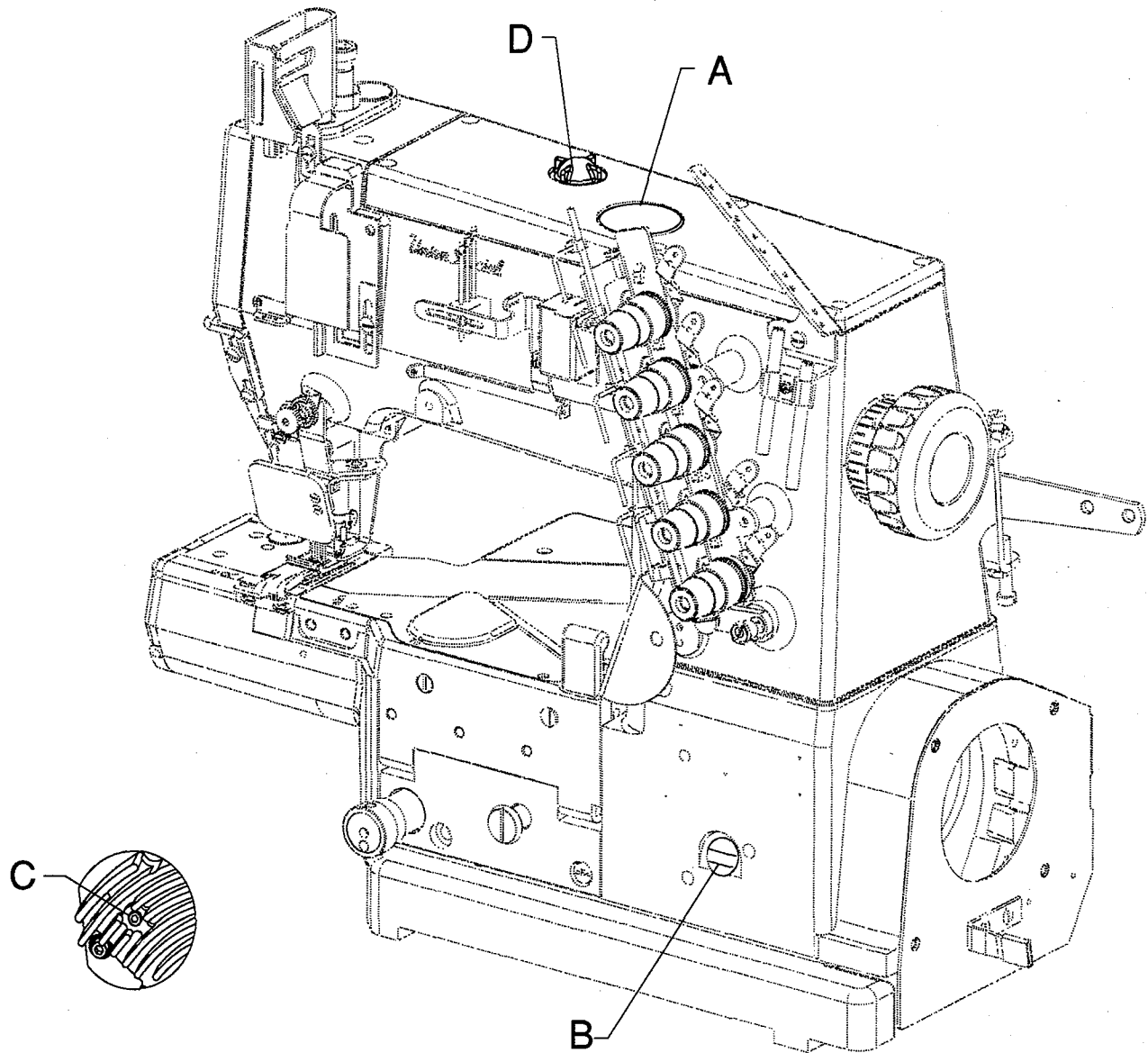

The oil should be between the two red lines in sight gauge (B) when the machine is at rest.

1. If oil is required remove oil cap (A).
2. Fill between lines (B) with Union Special Specification 175 oil (Union Special Part No. 28604R).



CAUTION: Do not exceed the upper red marker line. Excessive oil in the machine will result in oil leakage and possible overheating.

3. To drain oil reservoir, remove oil drain cap (C) on the underside of the machine.
4. To ensure oil flow through machine, check oil flow window (D).

LUBRICATION (CONT.):

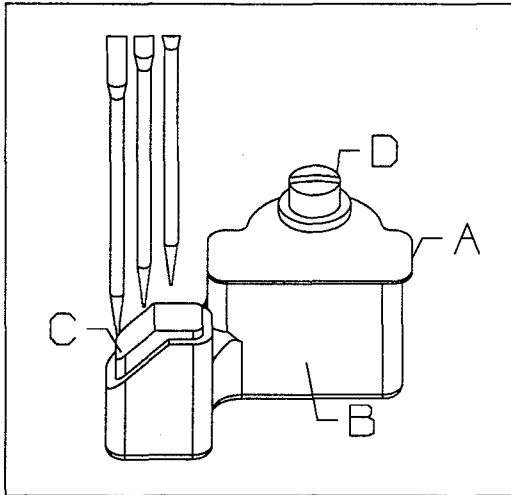

Lubrication of Needle Tip Dipper *(Optional, extra send charge item)

1. Open cloth plate and well cover (A), fill well (B) approximately 80% full with silicone oil.
2. The back of the needles should just touch the front of felt (C).
3. If adjustment is necessary loosen screw (D) and move dipper as required.
4. Saturate silicone oil into felt (C) if the machine is started immediately after lubricating needle tip dipper.

CLEANING OIL FILTER AND CHAMBER:

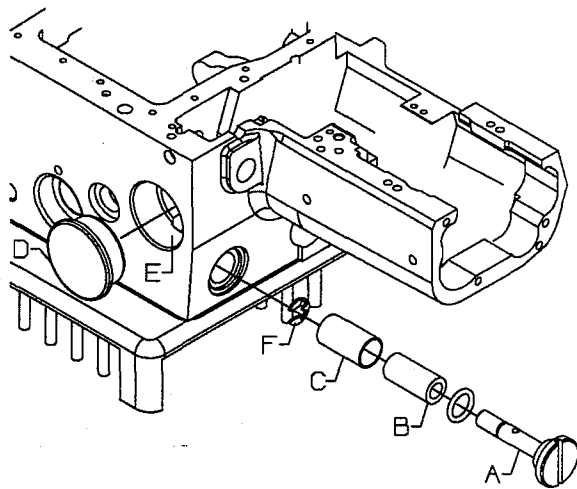

1. Oil filter (B) can be removed by turning mounting stud (A) counterclockwise.
2. Slide oil screen (C) and remove retainer (F).
3. Slide filter (B) off.
4. Slide new filter (B) back onto cleaned mounting stud (A), with oil screen (C) and retainer (F).
5. Remove plug (D) and wipe out chamber (E).
6. Wipe off plug (D) and replace into chamber (E).
7. Replace filter mounting stud (A) and retighten clockwise.
8. Verify oil level. Add oil if required.

NOTE: Oil filter (B) should be replaced every six months under normal use. Oil filter stud (A), oil screen (C) and chamber (E) must be cleaned every six months under normal use.

INSERTING NEEDLES:

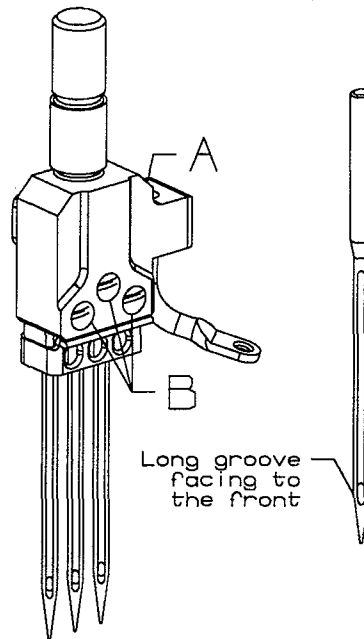

The standard needle is 121GJS, needle range sizes " 055/022 - 090/036."
Insert needles according to the following procedure:

1. Bring needle head (A) to the highest position.
2. Loosen screws (B), insert needles into holes. The needle scarf should face rearwards as viewed from the operator's side.
3. Retighten screws (B).

THREADING THE MACHINE:



Turn off main power switch before threading! When using clutch motors without actuation lock wait until the motor has completely stopped.

Thread the machine according to the following threading illustrations.

NOTE: When threading two needle machines use needles "A" & "C".

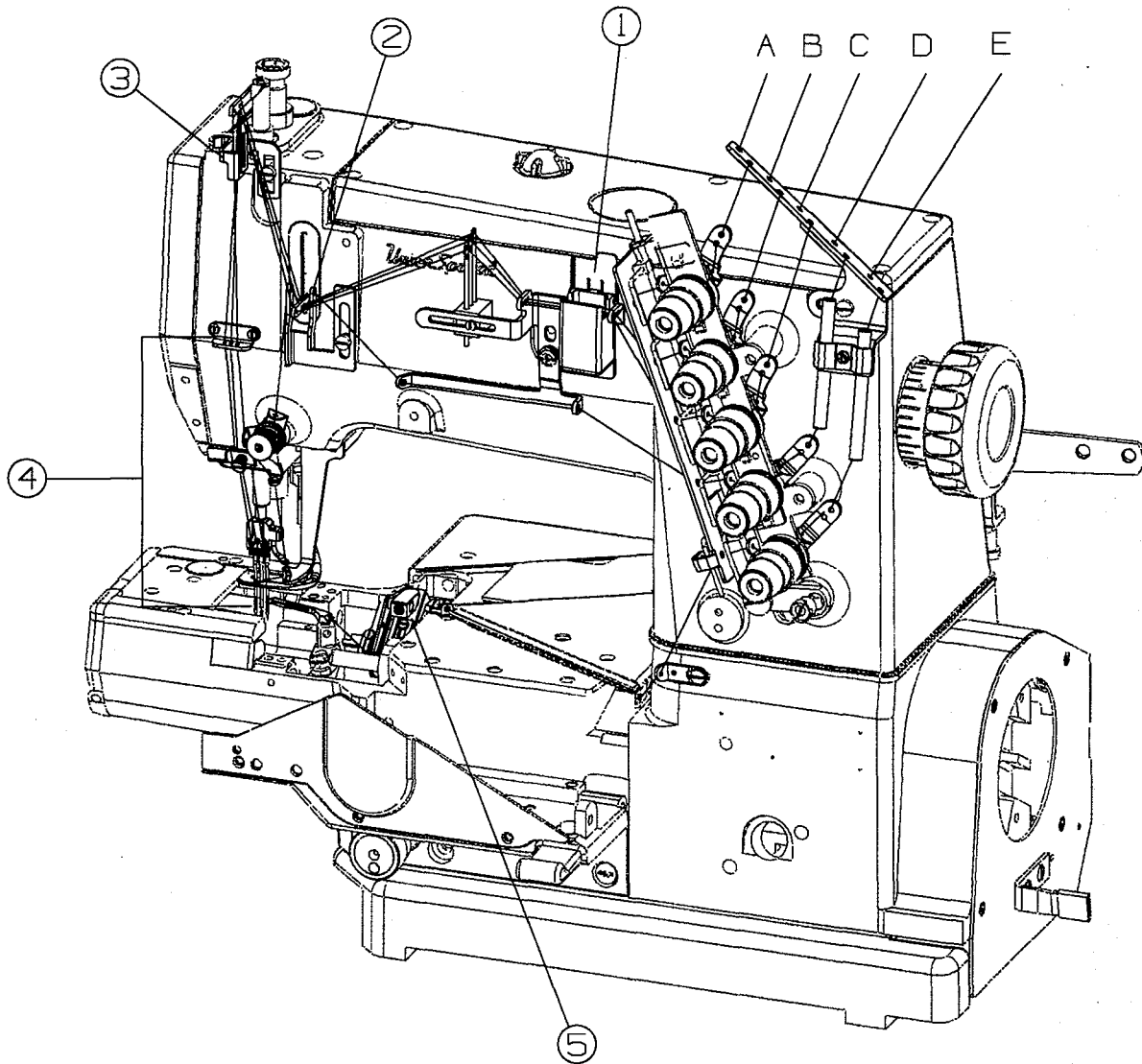

- | | |
|------------------------|--------------------------------|
| A Left Needle Thread | 1 Thread Lubricator Area |
| B Middle Needle Thread | 2 Needle Thread Eyelet Area |
| C Right Needle Thread | 3 Needle Bar Area |
| D Spreader Thread | 4 Thread Nipper, Spreader Area |
| E Looper Thread | 5 Thread Take-Up Area |

NOTE: When threading two needle machines use needles "A" & "C", DO NOT use needle "B".



THREADING THE MACHINE (CONT.):

NOTE: When threading two needle machines use needles "A" & "C".

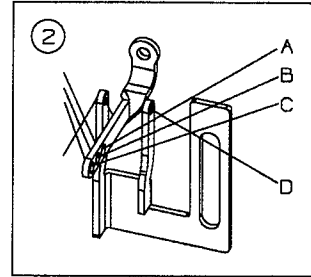
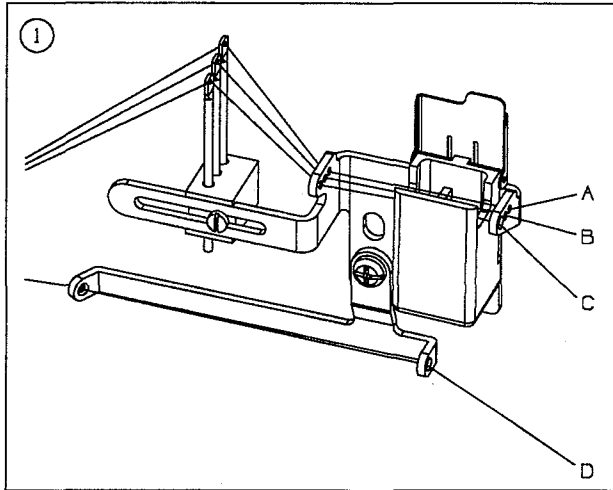

Needle Thread Eyelet Area

Thread Lubricator Area

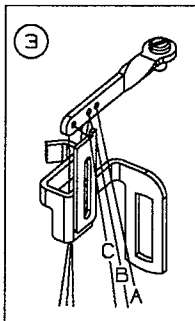

Needle Bar Area

Thread Nipper, Spreader Area

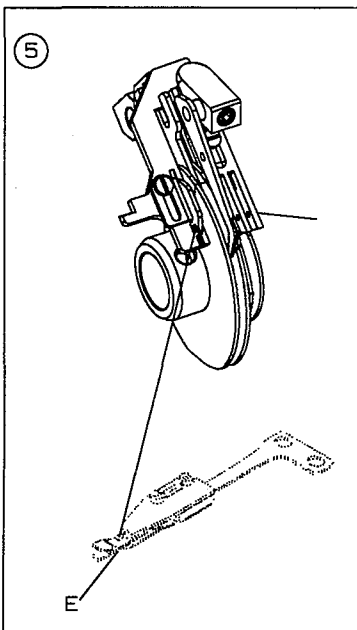
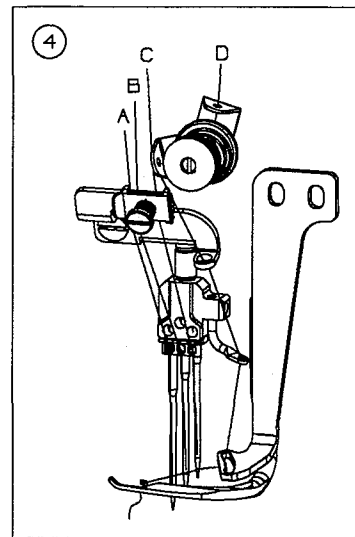

Thread Take-up Area



THREADING THE MACHINE (CONT.):

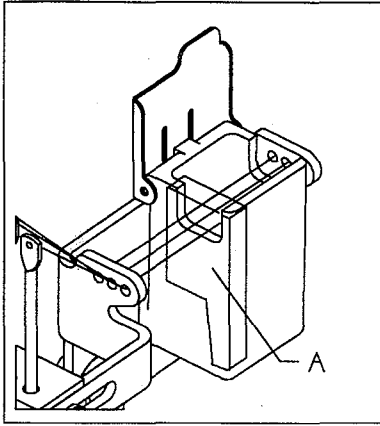

When the needle thread lubricator is used:

1. Saturate felt (A).
2. Pass thread over felt.

When the needle thread lubricator is not used:

1. Remove felt (A).

THREADING METHODS:

Twisted Thread

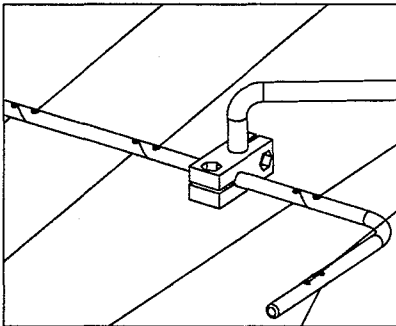

Non-Twist Thread

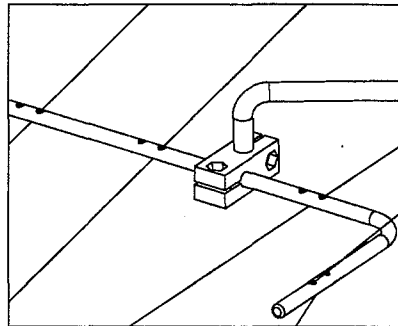

CAUTION!

When using an untwisted thread such as wooly nylon thread or weak thread, do not wind it around the immediate thread guide.

PRESSER FOOT PRESSURE AND LIFTER:

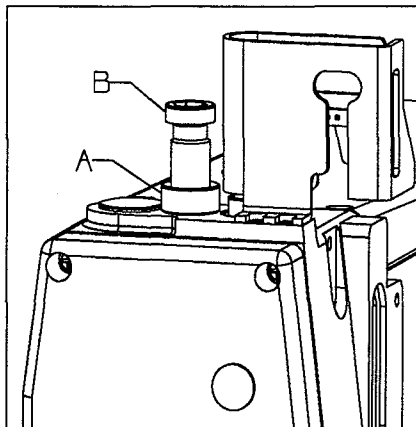

1. Adjust presser foot pressure by loosening nut (A) and turning presser foot adjust screw (B) clockwise to increase the pressure, counterclockwise to decrease the pressure.
2. Retighten nut (A).

ROLLER PRESSURE ADJUSTING KNOB:

1. To adjust the pressure for the puller drive roller assembly turn adjusting screw (A) clockwise to increase the pressure, counterclockwise to decrease the pressure.

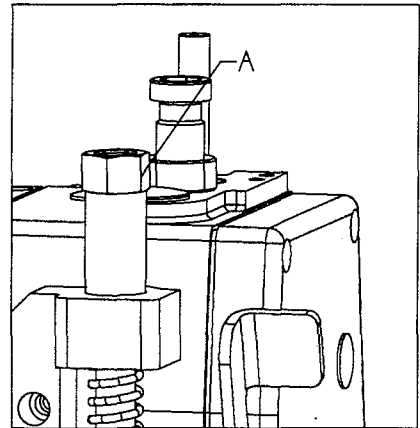

ADJUSTING THE STITCH LENGTH:



Turn off main power switch before setting the stitch length! When using clutch motors without actuation lock wait until the motor has completely stopped.

1. Locking feature may be engaged, refer to Engineer's Manual EN9424.
2. To change stitch length push down on stitch regulator button (A) and rotate handwheel in appropriate direction.

Clockwise to increase the stitches per inch/shorten the length of one stitch.

Counterclockwise to decrease stitches per inch/increase the length of one stitch.

3. The arrows on the belt cover are for operator's reference only.

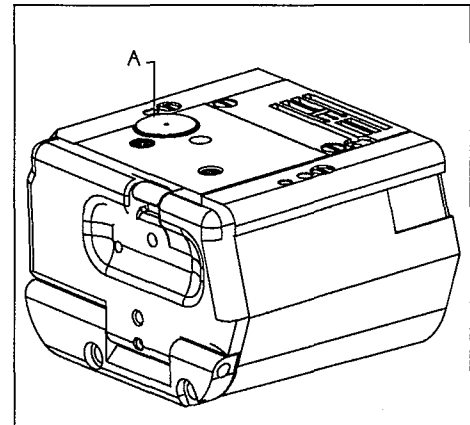

PULLER STITCH LENGTH:

1. Moving lever (A) towards or away from operator set stitch length of puller.
 - Set closer to operator for short stitches
 - Set farther away from operator for longer stitches
2. Loosen nut (B) and move lever (A) as needed to obtain proper stitch length.

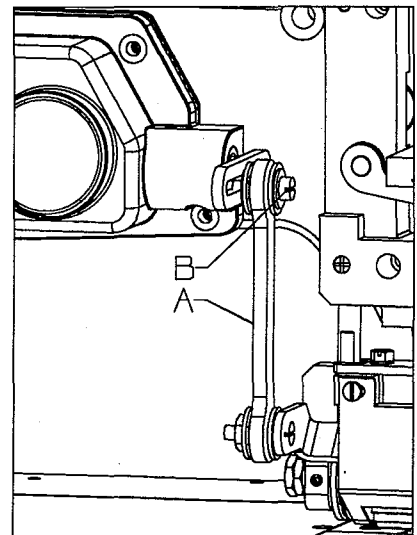

DIFFERENTIAL FEED MECHANISM:

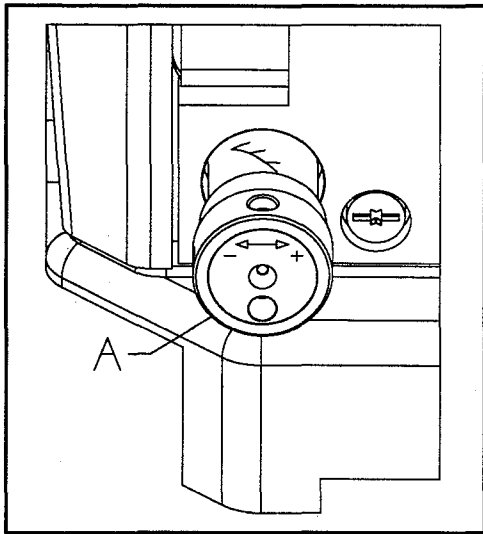

1. Turn knob (A) to change the travel of the differential feed dog.

Clockwise to increase the stitches per inch/shorten the length of one stitch.

Counterclockwise to decrease stitches per inch/increase the length of one stitch.

PULLER LIFTER LEVER:

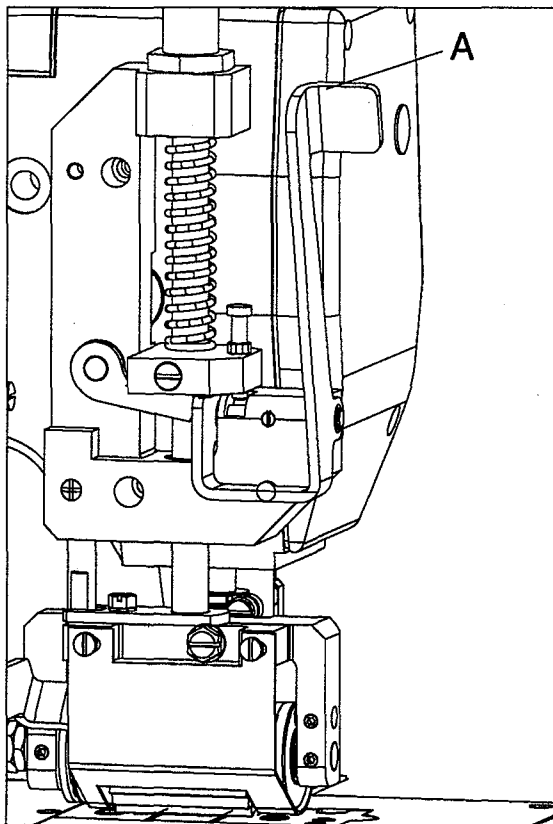

1. To engage puller roller to material, push lifter lever (A) away from the operator.
2. To disengage puller roller to material, pull lifter lever (A) towards the operator.

FOLDER ADJUSTMENTS:

1. Loosen screw (A) to adjust the right edge of the hem guide.
2. Loosen screw (B) to adjust the left edge of the hem guide.
3. Retighten screws.

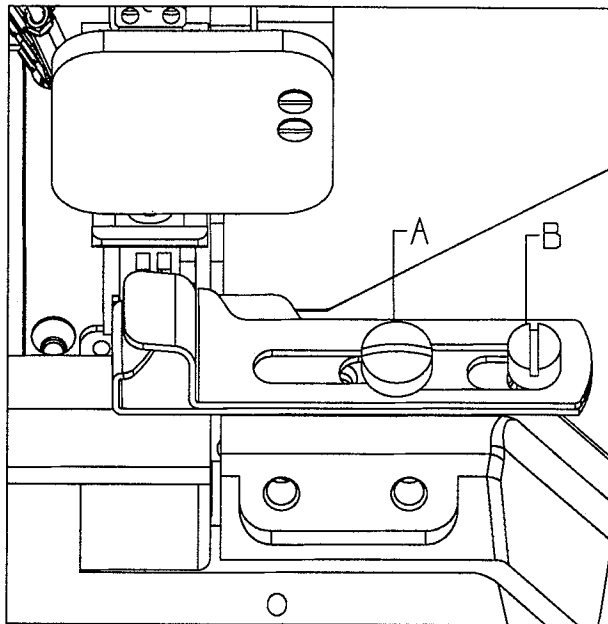

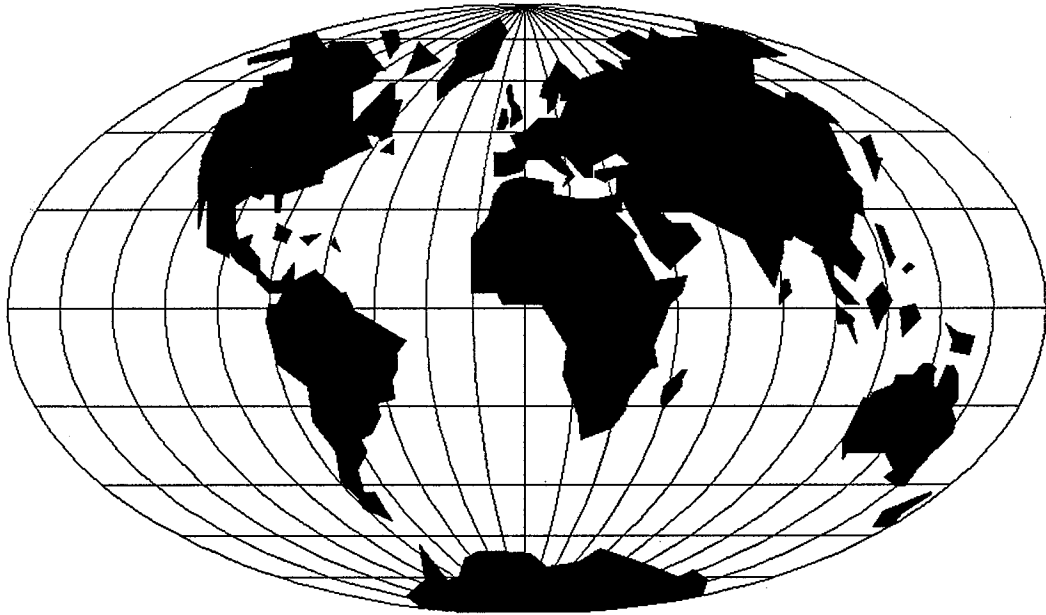

WORLDWIDE SALES AND SERVICE

Union Special Corporation maintains sales and service facilities throughout the world. These offices will aid you in the selection of the right sewing equipment for your particular operation. Union Special Corporation representatives and service technicians are factory trained and are able to serve your needs promptly and efficiently. Whatever your location, there is a qualified representative to serve you.

Corporate Office: One Union Special Plaza
Huntley, IL 60142
Phone: 847•669•5101
Fax: 847•669•4454

European Distribution Center: Union Special GmbH
Raiffeisenstrasse 3
D-71696 Möglingen, Germany
Tel: 49•07141•247•0
Fax: 49•7141•247•100

Brussels, Belgium
Charlotte, N.C.
El Paso, TX
Hong Kong, China
Huntley, IL
Leicester, England
Lille, France
Miami, FL
Milan, Italy
Möglingen, Germany
Montreal, Quebec
Osaka, Japan
Santa Fe Springs, CA

Other Representatives throughout
all parts of the world.



Union Special
INDUSTRIAL SEWING EQUIPMENT