

**CHANDLER MACHINE
USA**

**INSTRUCTIONS
&**

PARTS BOOK

CM-12P-2

**Chandler Machine USA,
LLC**

400 VETERANS BLVD, CARLSTADT NJ 07072

212-741-2474

TO CUSTOMERS:

Read the manual carefully:

Install the main operating rod with M6 inside hexagon spanner(2), fix the screw 6 and aim the main axle inside hole and then fix it

Up regulate foot

Put the pad well

Pull the operation rod. Regulate it(8) well if not to cut, loosen it first then adjust (7), after then fix(8)

The machine has been passed quality when out of the factory

ACCESSORIES

1.2 rubber pads

2.1 manual

3.1 hexagon spanner

4.4 feet

5.1 accessory plate

MAIN MACHINE FITTINGS

- 1 OPERATION TABLE
- 2 OPERATION HANDLE
- 3 OPERATION HANDLE SCREW
- 4 MAIN BLADE
- 5 CUTTER CARRIER
- 6 SUPPORTING POLE
- 7 CUTTER REGULATING SCREW
- 8 FUR SCREWS
- 9 REGULATING FOOT
- 10 MAIN AXLE
- 11 CUTTING BOARD
- 12 TABLE EXTENSION

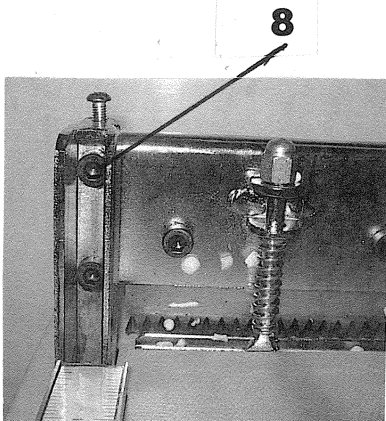
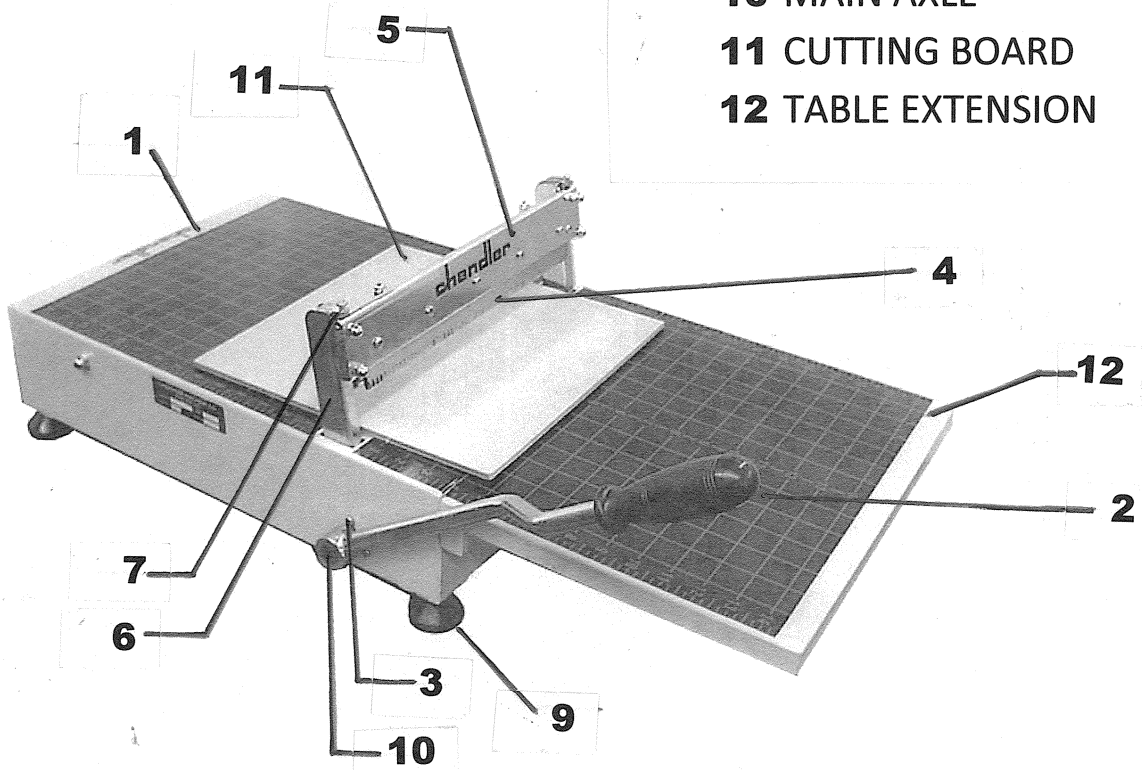

2---M6 SCREWS INSIDE, FOR REGULATING THE DEPTH OF THE BLADE.

BACK COVER

CM-12P-2

**Chandler Machine USA,
LLC**

400 VETERANS BLVD, CARLSTADT NJ 07072

212-741-2474