

FINEST QUALITY

Union Special[®]
LEWIS[®] • COLUMBIA[®]

**INDUSTRIAL
SEWING
MACHINES**

**CLASSES
61800
62200**

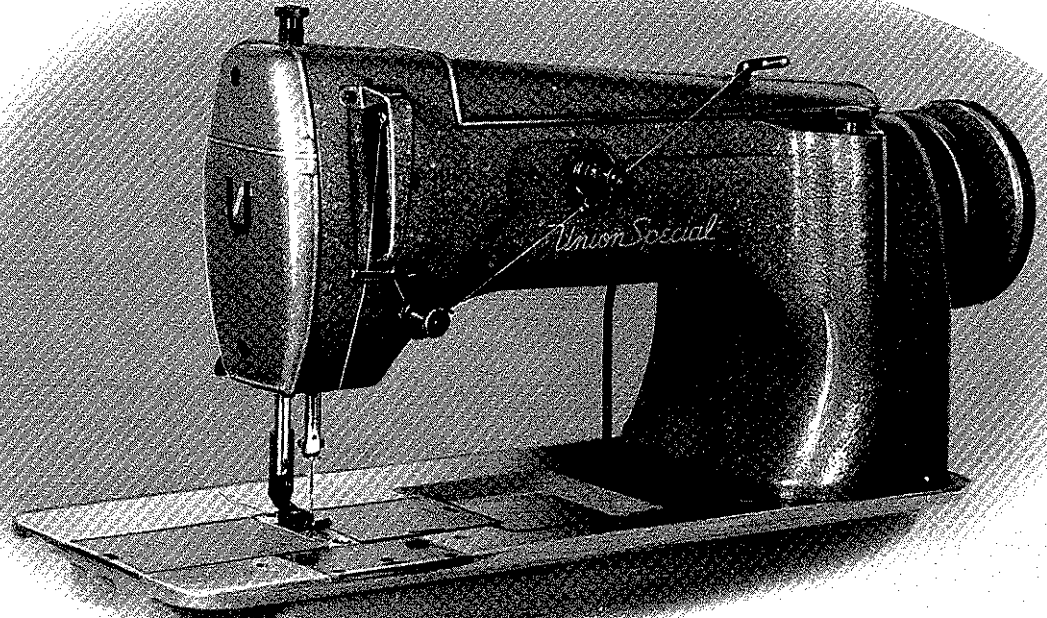

STYLE 61800 CA

**STREAMLINED
NEEDLE FEED
VERTICAL HOOK
LOCKSTITCH MACHINES**

**CATALOG
No.
101 R**

UNION SPECIAL CORPORATION

CHICAGO

Catalog No. 101 R

INSTRUCTIONS

FOR

ADJUSTING AND OPERATING

and

LIST OF PARTS

FOR

CLASSES 61800, 62200

Streamlined, Vertical Hook, Needle Feed Lockstitch Machines
Styles

61800 C	62200 G
61800 D	62200 H
61800 H	62200 K
61800 CA	62200 L
61800 DA	62200 GA
61800 HA	62200 HA
	62200 KA
	62200 LA

First Edition

Copyright 1960, 1968
by
Union Special Corporation
Rights Reserved in All Countries

UNION SPECIAL CORPORATION

INDUSTRIAL SEWING MACHINES

CHICAGO

Printed in U.S.A.

April, 1979

IDENTIFICATION OF MACHINES

Each UNION SPECIAL machine is identified by a style number which is stamped into the name plate on the machine. Style numbers are classified as standard and special. Standard Style numbers have one or more letters suffixed, but never contain the letter "Z". Example: "Style 61800 C". Special Style numbers contain the letter "Z". When only minor changes are made in a standard machine, a "Z" is suffixed to the Standard Style number. Example: "Style 61800 CZ".

Styles of machines similar in construction are grouped under a Class number which differs from the Style number, in that it contains no letters. Example: "Class 61800".

APPLICATION OF CATALOG

This catalog applies specifically to the Standard Styles of machines as listed herein. It can also be applied with discretion to some Special Styles of machines in these Classes. Reference to directions, such as right, left, front, back, etc., are given from the operator's position while seated at the machine. Operating direction of handwheel is toward the operator.

STYLES OF MACHINES IN CLASS 61800 AND 62200

Streamlined Flat Bed Lockstitch Machines, Light, Medium and Heavy Duty, Needle Feed and Drop Feed, Rotary Hook, Vertical Hook Shaft, Thumb Screw Stitch Regulator with Locking Device, External Needle Thread Tension Mechanism, One Reservoir Enclosed Automatic Lubricating System for Main Driving Mechanism, Automatic or Manual Head Lubrication, Separate Reservoir for Automatic Lubrication of Rotary Hook Mechanism. Maximum Work Space to Right of Needle Bar 10 Inches.

- 61800 C Single Needle Machine with manual lubrication for head, for miscellaneous seaming operations on light, medium and heavy weight materials; equipped with hinged bottom presser foot. 24-3 cord is maximum usable thread size. Type 180 GXS or 180 GYS needle. Specify needle type and size. Maximum recommended speed 4000 R.P.M.
- 61800 D Single Needle Machine with manual lubrication for head, for top stitching waist bands of trousers and similar operations; equipped with double action compensating presser foot, to compensate for uneven thickness of materials. 24-3 cord is maximum usable thread size. Type 180 GXS or 180 GYS needle. Specify needle type and size. Maximum recommended speed 4000 R.P.M.
- 61800 H Single Needle Machine with manual lubrication for head, for miscellaneous seaming operations on medium and medium heavy weight materials, requiring the use of heavy threads; equipped with hinged bottom presser foot. 16-4 cord is maximum usable thread size. Type 182 GAS needle. Maximum recommended speed 4000 R.P.M.
- 61800 CA Same as Style 61800 C, except equipped with automatic lubrication for head.
- 61800 DA Same as Style 61800 D, except equipped with automatic lubrication for head.
- 61800 HA Same as Style 61800 H, except equipped with automatic lubrication for head.

STYLES OF MACHINES IN CLASS 61800 AND 62200 (Continued)

- 62200 G Two Needle Machine with manual lubrication for head, for miscellaneous seaming operations on work shirts, overalls, work pants, dungarees, corsets and other foundation garments, jackets, shop coats, aprons and similar light, medium and heavy weight articles. 24-3 cord is maximum usable thread size. Type 180 GXS or 180 GYS needle. Specify needle type and size. Standard gauges Nos. 8, 12, 16, 20, 24, 28 and 32. Specify gauge. Maximum recommended speed 4000 R.P.M.
- 62200 H Two Needle Machine with manual lubrication for head, for miscellaneous operations on overalls, western type dungarees, jackets, medium weight canvas, upholstery and similar items requiring the use of heavy thread. 16-4 cord is maximum usable thread size. Type 182 GAS needle. Standard gauges Nos. 12, 16, 20, 24, 28 and 32. Specify gauge. Maximum recommended speed 4000 R.P.M.
- 62200 K Two Needle Machine with manual lubrication for head, for quality control along the edges and when turning corners, while taping brassieres, and for taping top, bottom, gore seams and reinforcement seams on corsets. Tape reel furnished with machine. Folder has 1/32 inch capacity, takes 5/8 inch wide tape and finishes 5/16 inch wide. Seam Specification 301-LSK-2. Type 180 GYS needle. Standard gauge No. 12 only. Maximum recommended speed 4000 R.P.M.
- 62200 L Two Needle Machine with manual lubrication for head, general utility machine for chaining on short operations such as hemming pockets. Equipped with positive chaining parts. Type 180 GXS or 180 GYS needle. Standard gauge No. 12 only. Maximum recommended speed 4000 R.P.M.
- 62200 GA Same as Style 62200 G, except equipped with automatic lubrication for head.
- 62200 HA Same as Style 62200 H, except equipped with automatic lubrication for head.
- 62200 KA Same as Style 62200 K, except equipped with automatic lubrication for head.
- 62200 LA Same as Style 62200 L, except equipped with automatic lubrication for head.

NEEDLES

Each UNION SPECIAL needle has both a type and size number. The type number denotes the kind of shank, point, length, groove, finish and other details. The size number, stamped on the needle shank, denotes largest diameter of the blade, measured in thousandths of an inch across the eye. Collectively, the type and size number represent the complete symbol, which is given on the label of all needles packaged and sold by Union Special.

To have needle orders promptly and accurately filled, an empty package, a sample needle, or the type and size number should be forwarded. Use description on label. A complete order would read: "1000 Needles, Type 180 GXS, size 090/036".

NEEDLES (Continued)

The type numbers of the needles recommended for each style of machine covered by this catalog are given in the machine style description. Other needles are available, but the ones indicated are those recommended to produce the most satisfactory results. The type numbers of the recommended needles together with their descriptions, and the sizes available are listed below:

<u>Type No.</u>	<u>Description and Sizes</u>
180 GXS	Round shank, round point, lockstitch, short length, ball eye, single groove, wide angle groove, struck groove, deep spot, ball point, chromium plated - sizes 075/029, 080/032, 090/036, 100/040, 110/044, 125/049, 140/054, 150/060.
180 GYS	Round shank, round point, lockstitch, short length, ball eye, single groove, wide angle groove, struck groove, deep spot, chromium plated - sizes 075/029, 080/032, 090/036, 100/040, 110/044, 125/049, 140/054, 150/060.
182 GAS	Round shank, round point, lockstitch, long length, ball eye, single groove, struck groove, deep spot, chromium plated - sizes 110/044, 125/049, 140/054, 150/060, 170/067.

Selection of proper needle size is determined by size of thread used. Thread should pass freely through needle eye in order to produce a good stitch formation.

Success in the operation of UNION SPECIAL machines can be secured only by use of needles packaged under our brand name, *Union Special*[®], which is backed by a reputation for producing highest quality needles in materials and workmanship for more than three-quarters of a century.

IDENTIFYING PARTS

Where the construction permits, each part is stamped with its part number. Parts too small for a complete catalog stamping are identified by letter symbols which distinguish one part from another that is similar in appearance.

Part numbers represent the same part, regardless of the catalog in which they appear.

IMPORTANT! ON ALL ORDERS, PLEASE INCLUDE PART NAME AND STYLE OF MACHINE FOR WHICH PART IS ORDERED.

TERMS

Prices are net cash and subject to change without notice. All shipments are forwarded f.o.b. shipping point. Parcel Post shipments are insured unless otherwise directed. A charge is made to cover the postage and insurance.

ORDERING REPAIR PARTS

ILLUSTRATIONS

This catalog has been arranged to simplify the ordering of repair parts. Exploded views of various sections of the mechanism are shown so that the parts may be seen in their actual position in the machine. Small keyline views show by a blackened area where the parts fit in the assembled machine. On the page opposite the illustration will be found a listing of the parts with their part numbers, descriptions and the number of pieces required in the particular view being shown.

ILLUSTRATIONS (Continued)

Numbers in the first column are reference numbers only, and merely indicate the position of that part in the illustration. Reference numbers should never be used in ordering parts. Always use the part number listed in the second column.

Component parts of sub-assemblies which can be furnished for repairs are indicated by indenting their descriptions under the description of the main sub-assembly. Example:

Ref. No.	Part No.	Description	Amt. Req.
50	51239 L	Feed Driving Connection Ball Joint, upper -----	1
51	97 A	Screw -----	2

It will be noted in the above example that the bearing and the ball stud are not listed. The reason is that replacement of these parts individually is not recommended, so the complete sub-assembly should be ordered.

Basically, Classes 61800 and 62200 are the same except Class 61800 is a single needle machine, while Class 62200 is a two needle machine; therefore, all parts for the standard machine are the same. In some cases, the quantity requirement is changed. In those cases where a part is common to all the machines covered by this catalog, no specific usage will be mentioned in the description. However, when the parts for the various machines are not the same, the specific usage will be mentioned in the description, and if necessary, the difference will be shown in the illustration.

At the back of the book will be found a numerical index of all the parts shown in this catalog. This will facilitate locating the illustration and description when only the part number is known.

OILING INSTRUCTIONS

There are three oil reservoirs on Class 62200 machines which are filled through oil cups "C", "D" and "E" (Fig. 1) on Styles 62200 G, H, K and L. For Styles 62200 GA, HA, KA and LA the reservoirs are filled through oil cups "A", "B" and "C" (Fig. 1A).

Each hook is automatically lubricated from its own reservoir by a spiral oil screw. The amount of oil required for each hook may be adjusted by a metering screw located at the bottom of each reservoir. To increase or decrease the amount of oil supplied to the hook, first loosen nut and then turn metering screw counterclockwise to increase the amount of oil or clockwise to decrease the amount of oil supplied to the hook. Tighten nut after adjusting the metering screw. The main reservoir which houses the gears, stitch regulating mechanism, needle feed driving mechanism, upper main shaft, etc., lubricates these parts by a splash action and also supplies oil to the lower feed mechanism through the lower main shaft.

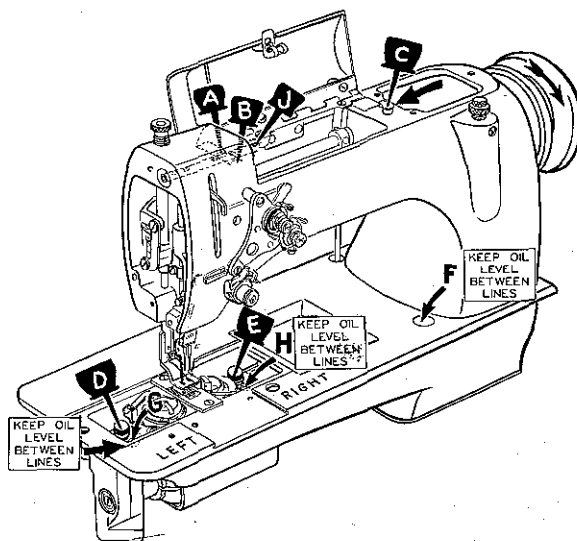
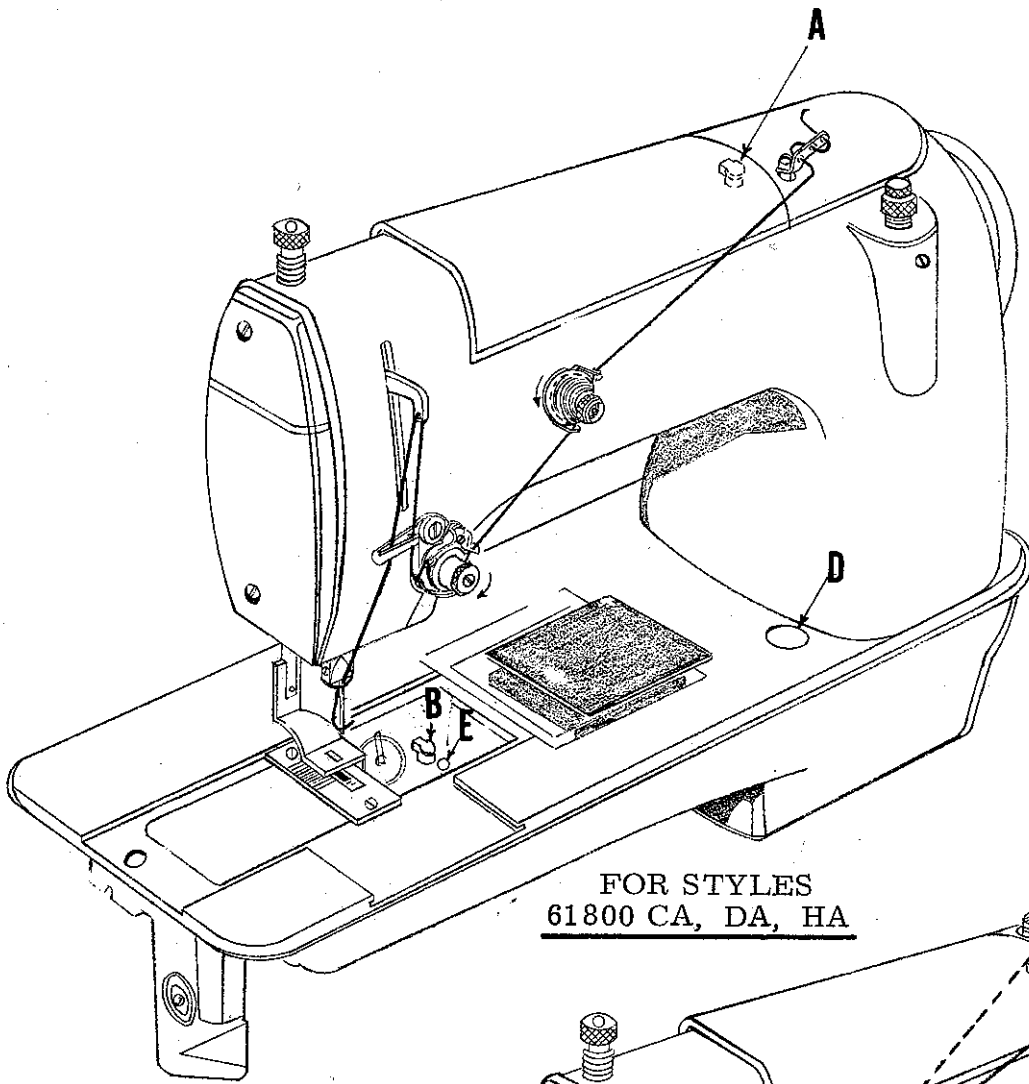
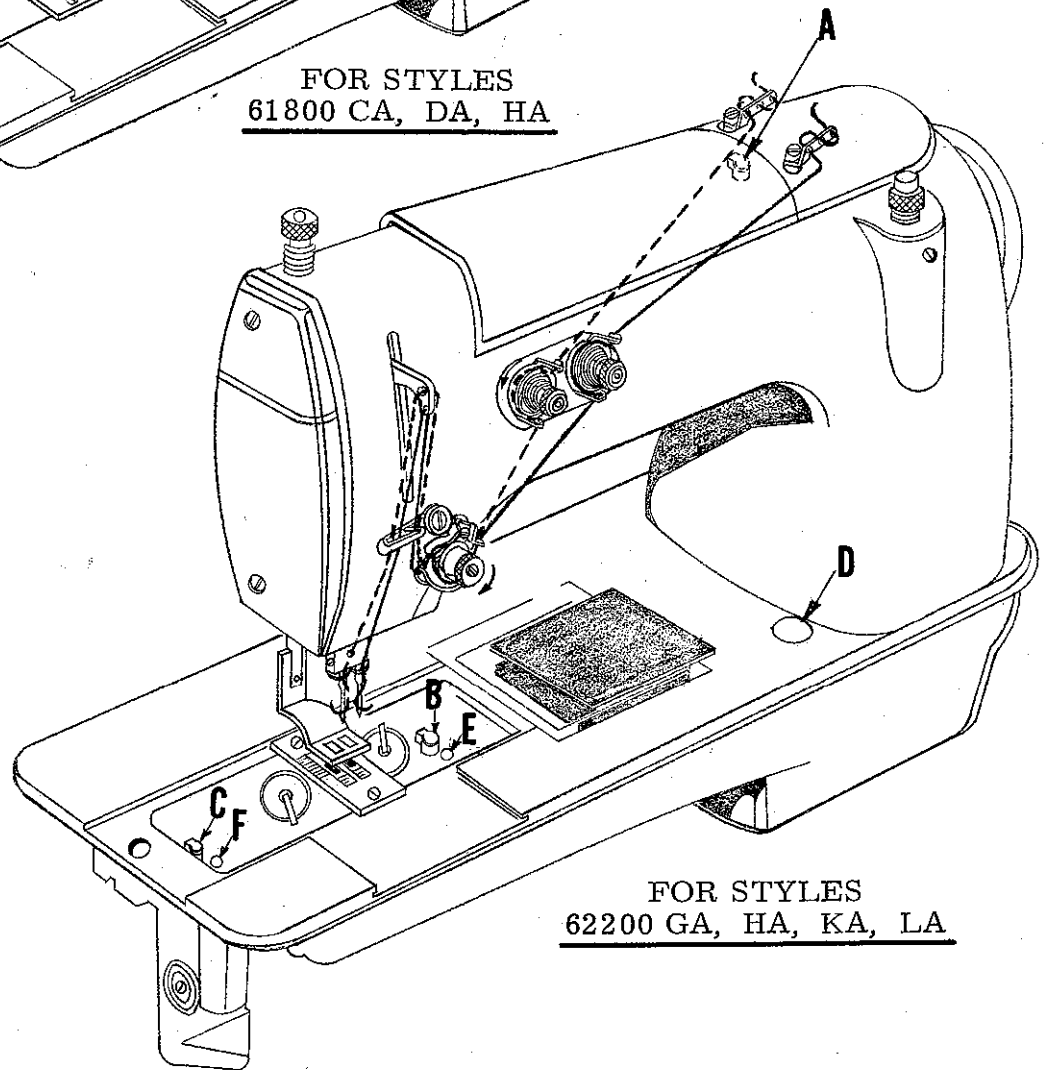

Fig. 1



FOR STYLES
61800 CA, DA, HA



FOR STYLES
62200 GA, HA, KA, LA

Fig. 1A

OILING INSTRUCTIONS (Continued)

On Styles 62200 G, H, K and L, the level of oil in the three main reservoirs can readily be observed at the lucite gauges "F", "G" and "H" (Fig. 1). The level of oil in the three main reservoirs on Styles 62200 GA, HA, KA and LA, can be observed at the lucite gauges "D", "E" and "F" (Fig. 1A).

The manually oiled holes "A", "B" and "J" (Fig. 1) lubricates the head mechanism, the left upper main shaft bearing and the needle bar frame pivot pin, respectively, on Styles 62200 G, H, K and L.

Use a straight mineral oil of a Saybolt viscosity of 90 to 125 seconds at 100° Fahrenheit in all reservoirs and all oiling places. On Styles 62200 G, H, K and L, lubricate points "A", "B" and "J" (Fig. 1) twice daily depending on operating conditions. Add oil to cups as outlined in paragraph 1 and maintain oil levels between lines on lucite gauges, as outlined in paragraph 3.

CAUTION! The main reservoir is drained before the machine is shipped and must be filled before starting to operate. Check the hook reservoirs to be sure that the oil is at the proper level. If oil has been drained from hook reservoir and refilled, loosen nut and turn metering screw approximately 6 complete turns counter-clockwise. Now run machine slowly until oil appears at hook, then turn metering screw clockwise to adjust for the proper flow of oil to the hook.

NOTE: The oiling for Styles 61800 C, D and H are the same as for Styles 62200 G, H, K and L, except there is only one hook reservoir, thus no "D" oil cup or "G" (Fig. 1) lucite oil gauge. Also the oiling for Styles 61800 CA, DA and HA are the same as for Styles 62200 GA, HA, KA and LA, except there is only one hook reservoir, thus no "C" oil cup or "F" (Fig. 1A) lucite oil gauge.

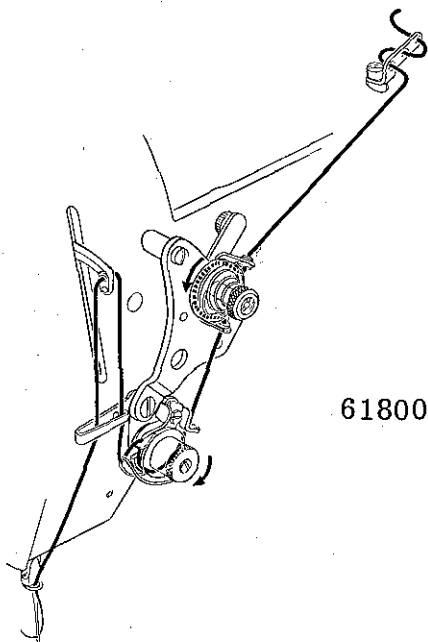

Fig. 2

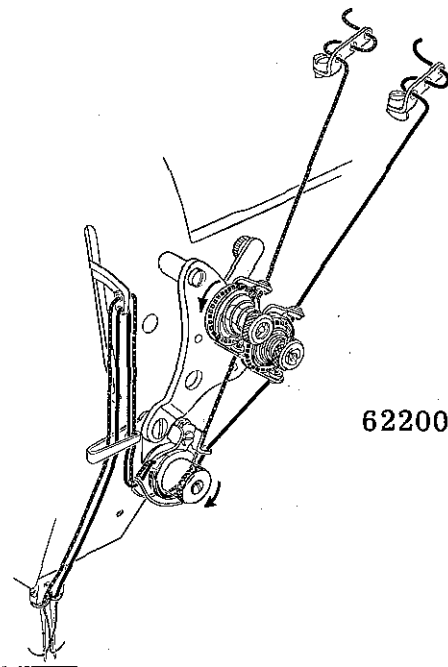

Fig. 3

THREADING

Thread machines as indicated in Fig. 1A, 2 or 3, depending on the Style of machine. Use Fig. 1A for Styles 61800 CA, DA, HA, 62200 GA, HA, KA or LA; use Fig. 2 for Styles 61800 C, D or H; and use Fig. 3 for Styles 62200 G, H, K or L. The needle on Class 61800 and the right needle on Class 62200 are inserted with the spot (sometimes called scarf) to the right and the thread passes through the needle from left to right. The left needle of Class 62200 is inserted with the spot to the left and the thread passes through the needle from right to left.

WINDING THE BOBBIN

Thread the bobbin winder by leading the thread from the supply down through the eyelet (A, Fig. 4), down between the tension discs, and under the tension post. Press an empty bobbin on the winder shaft (B) up to the stop, wind the end of thread around the bobbin a few turns in a clockwise direction and press downwardly on hand lever (C) until pulley is moved into contact with machine belt, and is locked in that position. When the machine is operated, the bobbin will be rotated and filled until the thread engages the automatic throwout member, which disengages the pulley. The extent to which the bobbin is filled can be varied by the regulating screw (D).

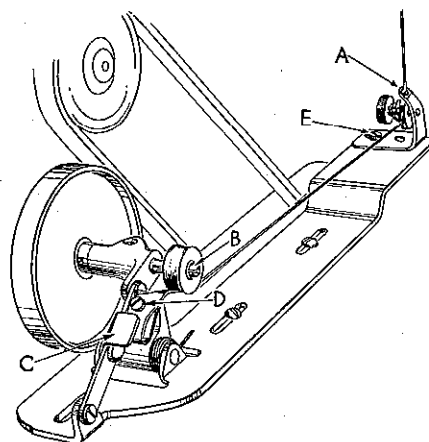

Fig. 4

The tension post bracket is mounted on the winder base, and can be shifted from left to right by loosening screw (E), so that any tendency of the bobbin to wind unevenly may be readily corrected.

The purpose of the bobbin winder is to assure the operator a full bobbin at all times. When the bobbin in the machine is used up, replace it with a full one and begin to wind the empty bobbin immediately. Bobbins can be rewound while machine is sewing.

INSERTING THE BOBBIN

Place the bobbins in the hooks so that they unwind in the opposite direction to that of the hook rotation (Fig. 5). Pull the threads into the slots of the bobbin cases (A). This operation will bring the bobbin threads between the tension springs and the bobbin cases. Adjust bobbin thread tension, by regulating the pressure on spring (B) with screw (C) on both bobbin cases, so that there is a slight drag on the thread. Make sure that the bobbin thread is between the tension spring and bobbin case.

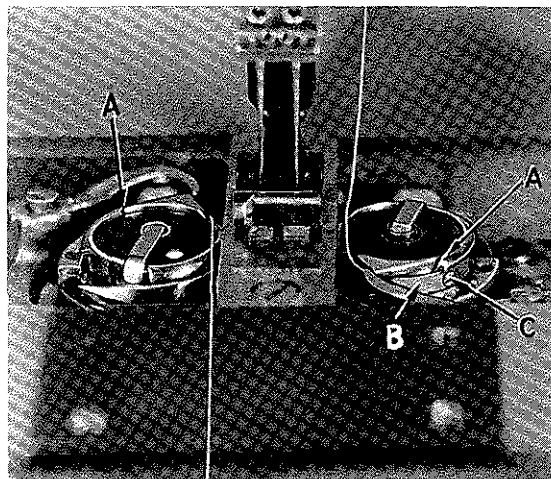

Fig. 5

ADJUSTING INSTRUCTIONS FOR MECHANICS

CHECKING THE FLOW OF OIL FROM THE HOOK SHAFTS

Oil is filtered to the hook shafts from the oil reservoirs. All of the hook opener mechanisms are maintained in peak operative condition by running in oil. Daily checks for adequate oil supply in the reservoirs are important.

CHECKING THE FLOW OF OIL FROM THE HOOK SHAFTS (Continued)

The metering pins (A, Fig. 6) are the control screws for the quantity of oil flowing to the hooks. Regulate these pins somewhere between 1/2 and 3/4 of a turn from the closed position for normal flow requirements.

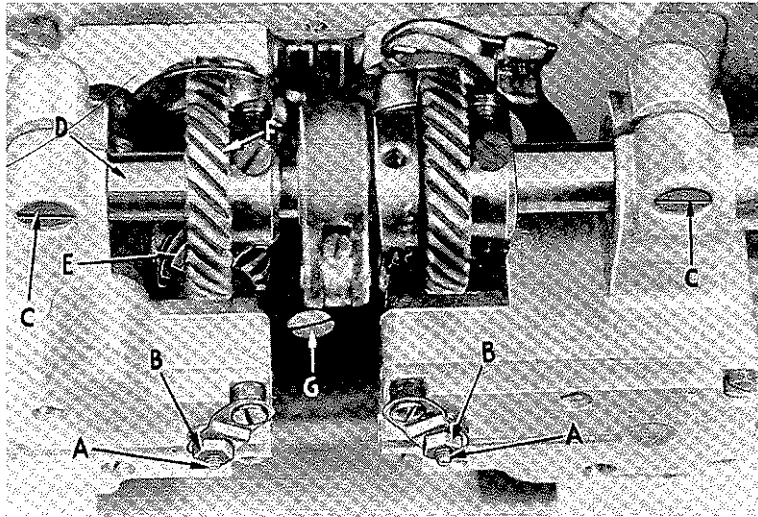

Fig. 6

Check and regulate the flow of oil to the hook shafts, by first, loosening the lock nuts (B, Fig. 6) and with the fingers, opening the metering pins 4 or 5 turns to allow a test of maximum flow of oil to the hooks. Tighten the nuts, run the machine until oil sprays from the shafts or hooks. Then loosen lock nuts, turn pins in until they set and back off 1/2 to 3/4 turn. Tighten lock nuts, and while holding a piece of yellow paper behind the hooks and parallel with the hook shafts, run the machine for about a minute to make sure that a fine spray of oil appears on the paper.

Additional checks are normally required at time of new installation and when refilling the reservoirs of machines that have been allowed to run completely dry.

NOTE: Check of oil from the hook shafts may also be made while hooks are out of the machine.

SETTING THE NEEDLE BAR

The setting of the needle bar (A, Fig. 7) to the proper needle bar height timing line will, in practically all cases, produce the optimum location of the needle loop with respect to the hook point for proper loop pick up.

A maximum "down" position of the needle bar may be established by turning the handwheel in the operating direction until the crank pin and the needle bar connecting link align perpendicular behind the needle bar. (Looking into end as shown by Fig. 7, pin and link cannot be seen).

Needle bar height adjustment is governed by the length of the needle used. Two sets of timing lines (B, Fig. 7) are engraved on every needle bar to assure accurate timing. The upper pair is used when Type 180 GXS or 180 GYS "short length" needles are specified and the lower pair is used with needle Type 182 GA "long length".

Set the upper timing line of the pair selected for timing (depending on the type needle being used) flush with the lower edge of the needle bar bushing (C). This is done by loosening screw (D) in the needle bar clamp and while holding the needle bar clamp in its "down" position, moving the needle bar as required. Tighten clamp screw at this position.

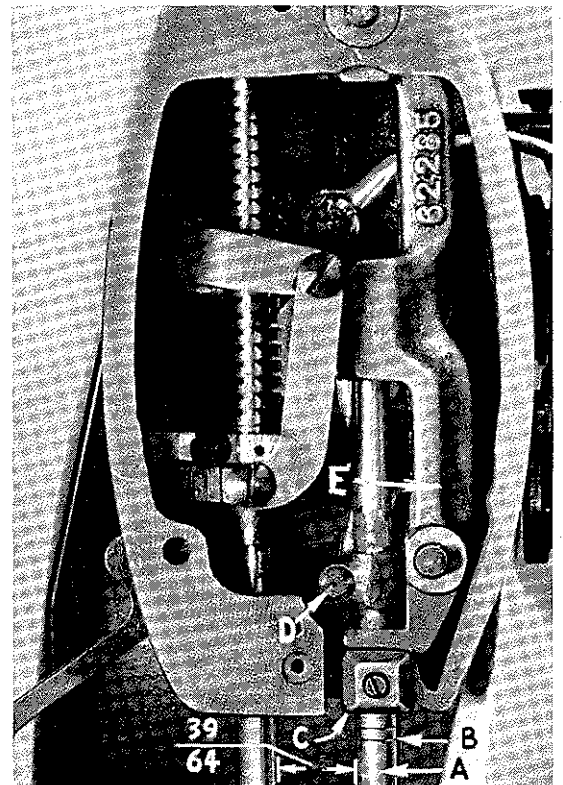

Fig. 7

SETTING THE NEEDLE BAR (Continued)

To position the needle bar in relation to the presser bar, first set the needle bar at the bottom of its stroke. Then, remove the top reservoir cover at the right end of the machine. Loosen clamp nut (A, Fig. 8) of the feed driving lever (B) and swing the needle bar frame (E, Fig. 7) forward or backward in the line of feed until the factory specified distance of $39/64$ to $5/8$ inch is obtained between the needle bar and the presser bar. (Gauge No. 21227 BL is available for measuring this adjustment). After needle bar meets required setting, tighten clamp nut (A, Fig. 8) and re-assemble cover.

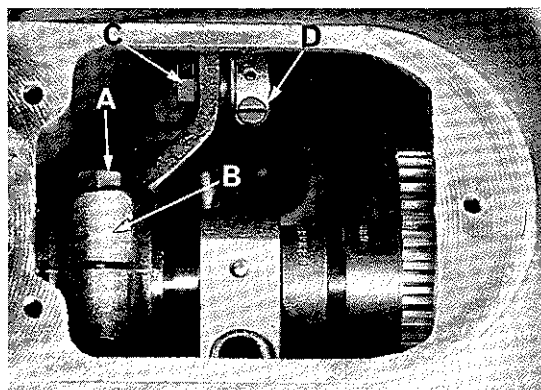

Fig. 8

TIMING

Timing is the synchronization between the upper main shaft and the lower main shaft.

To change or check the timing between the lower and upper main shafts, remove the head cover and the main gear case reservoir bottom cover (Fig. 9).

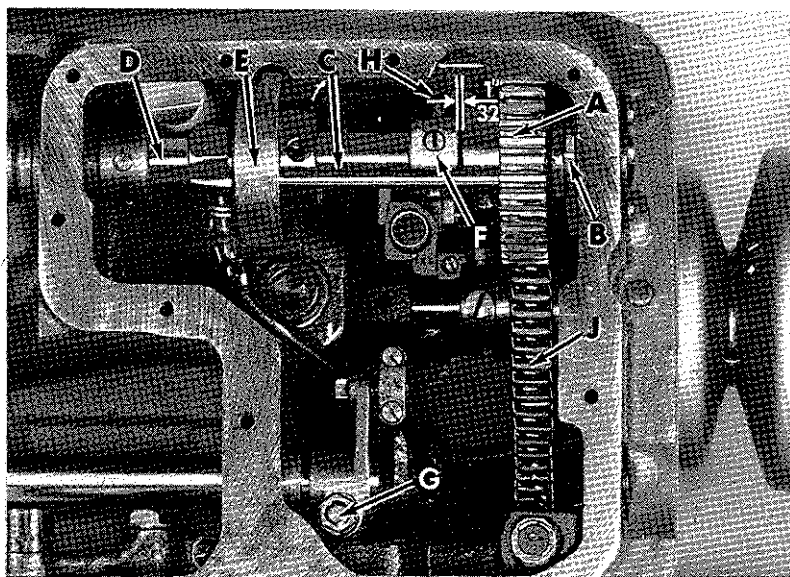

Fig. 9

Make certain (by a visual check) that the needle bar is in its maximum "down" position by turning the handwheel in operating direction until the crank pin and the needle bar connecting link align perpendicular behind the needle bar.

Timing between the needle bar and the feed lift eccentric (not illustrated but located on the lower feed shaft D, Fig. 6) is determined by angular relativity between flats of the upper and lower main shafts.

TIMING (Continued)

Upon location of the needle bar in its maximum "down" position, the timing may be checked by looking into the main reservoir at the bottom. If the machine is timed properly, the flexible coupling pin (C, Fig. 9) will line up with the center of the lower main shaft (D). It will also be noted that the end of the pin (C) which is held in gear (A) will line up with the small casting boss (B). Since the flexible coupling head (E) has two pins, located 180° apart, care must be taken to choose the correct pin for the timing check. The correct pin (C) which is the farthest away from the two hub securing screws, is to be used for this check.

If the feed timing is incorrect, loosen the two set screws on the main shaft collar (F, Fig. 9) and remove the bed casting screw (H). Now, slip the flexible coupling gear (A) to the left, far enough to disengage it from the idler (intermediate) gear (J). This will allow you to set the lower main shaft to the upper main shaft. After timing has been made, slip the flexible coupling gear (A) to the right to engage it with the idler (intermediate) gear (J). Replace the bed casting screw (H) and tighten securely. Move the main shaft collar (F) to the right, maintaining a 1/32 inch between it and the flexible coupling gear (A) when this coupling gear is fixed in operating position at extreme right. Tighten the two set screws on collar (F) securely.

If a finer adjustment is necessary, loosen nut (C, Fig. 8) and move ball joint (D) forward or backward as required. Tighten nut (C).

Final check on the timing can be made after machine is adjusted by observation of the entry of the needles into the feed dog needle holes (A, Fig. 10). The point of the needles should enter the feed dog holes as the feed dog is just passing the top of the throat plate.

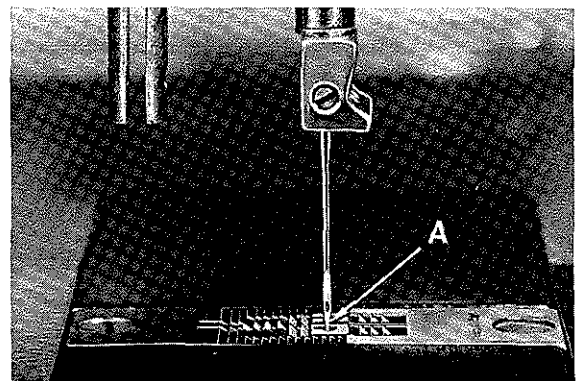

Fig. 10

LOCATING THE FEED DOG

Having previously spaced the needle bar with the presser bar, the position of feed dog with respect to the needles may be checked. The feed dog is to be so aligned in the line of feed that the needles will enter the needle holes at the center or just slightly to the front. Should an enlarged needle hole be required, countersink the feed dog from the top, and, if possible, do not enlarge the bottom of the needle hole.

To center needles in the feed dog in the line of feed, remove the bottom cover of the main reservoir exposing the clamp screw (G, Fig. 9) in the feed driving arm. Loosening the screw enables the feed rocker shaft to be rotated to secure the proper location of the feed dog. Retighten clamp screw and replace main reservoir bottom cover, after locating feed dog.

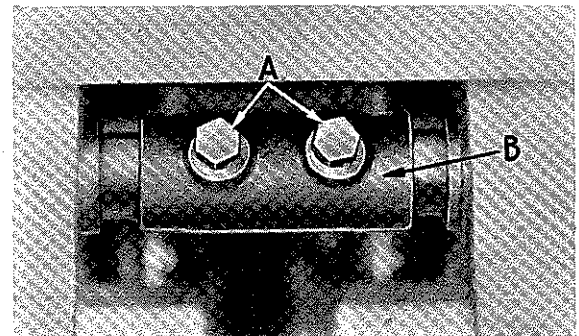

Fig. 11

To adjust the feed dog across the line of feed, loosen the feed rocker set screws (A, Fig. 11) and move the feed rocker (B) in the required direction to center the needle in the feed dog needle hole.

TIMING THE HOOKS

The correct position of the hooks on their shafts is of great importance. The timing between the hook opener finger and the hook is governed by the position of the hook timing screw on the hook shaft flat. If the wrong hook screw is placed on the flat, the hook opening finger will be out of time with the hook. The timing screw intended for the flat on the shaft is the first one visible as the hook is turned in operating direction.

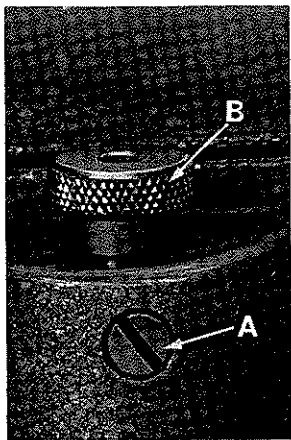

Fig. 12

Fig. 12 illustrates the stitch regulator. For timing the hooks, it is recommended the regulator be turned to produce shortest stitch length. To do this, loosen lock screw (A) and turn the stitch regulator (B) counterclockwise as far as possible. Lock in position by tightening lock screw (A).

Loosen the two screws on each of the hook shaft pinion gears (E, Fig. 6) so the hooks will turn freely with the hook shaft without turning the driving gears.

Visually check position of the needles. Make sure their spots face their respective hooks. Now, turn handwheel in operating direction to obtain a maximum "down" position of the needle bar. When this has been reached, continue to turn until lower timing line (of the pair selected) (B, Fig. 7) is flush with the bottom of the lower needle bar bushing. At this time, the hook point should be approximately 1/32 inch above needle eye.

The needle and the hook point should be approximately .003 inch apart (Fig. 13) while the needle guard is just brushing the needle (A) as the hook point is rotated back and forth across the needle. The hook needle guard may be bent slightly to obtain this condition.

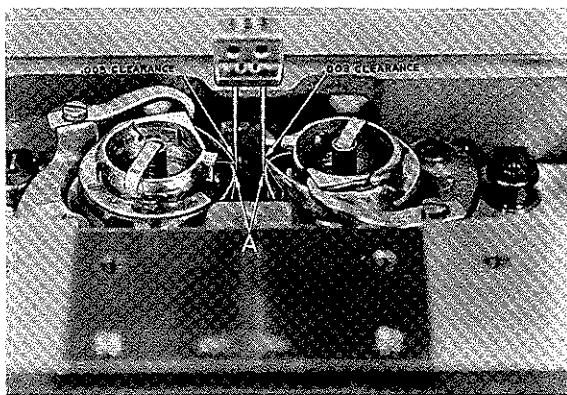

Fig. 13

Adjustment of the hooks, right or left, is accomplished by loosening the saddle screws (C, Fig. 6), and moving the hook saddles as required. (Note: Two screws in back are not shown).

After the saddle is correctly located and the retaining screws are tightened, (tightening the back screws first and the clamp screws last) the hook shaft driving gear (F, Fig. 6) should be centered on the hook shaft looking directly at the gear faces. The alignment of the driving gear and the hook shaft is extremely important if the maximum gear life and minimum gear sound are to be gained.

When the saddles and their driving gears have been correctly positioned, the hooks may be timed by using the timing marks on the needle bar (B, Fig. 14). To maintain permanently the hook in its properly timed position, tighten the set screws on the hook shaft driven gear (E, Fig. 6).

Whenever it is necessary for a hook to be removed after this initial timing, the hook need only be replaced on the shaft with the timing screw against the flat on the hook shaft as described in paragraph 1. Automatically, the hook retains its correctly timed position.

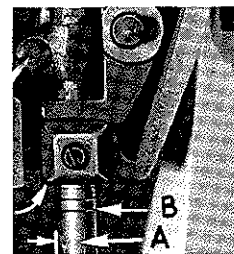

Fig. 14

SETTING THE FEED DOG HEIGHT

Place the throat plate in the machine. The approximate height of the feed dog teeth is .050 inch above the throat plate (Fig. 15) at the highest point of travel.

Height adjustment is accomplished by turning screw (G, Fig. 16) in the feed bar on which the bottom edge of the feed dog rests. Raise the feed dog to the desired height by turning the screw clockwise. To lower it, turn the screw in the opposite direction.

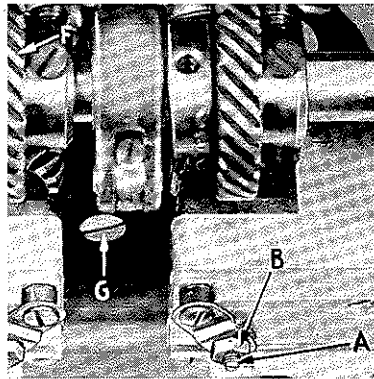

Fig. 16

To make this adjustment, loosen the clamp screw (B) on the opener finger lever and swing the lever to the proper position to obtain the 1/16 inch setting. The screw (D) is used to take up any vertical end play that may exist in the opener finger drive shaft. Now loosen screw (C) and move the opener finger approximately .005 inch away from the cam surface of the hook basket. Retighten screw.

ADJUSTING THE FOOT PRESSURE

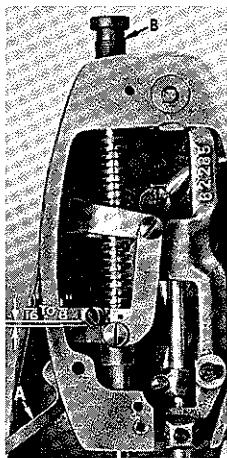

Fig. 18

The presser spring regulator (B, Fig. 18) atop the machine head, controls the amount of pressure on the presser foot. Turning the thumbscrew in counterclockwise direction decreases foot pressure, while clockwise turning increases it. Only enough pressure to feed the work uniformly is required.

With the hand lifter in down position (A, Fig. 18) the presser foot should rest securely on the throat plate. Approximately 1/16 to 1/8 inch should be maintained between the presser bar guide and the presser bar connection as the presser foot rests on the throat plate.

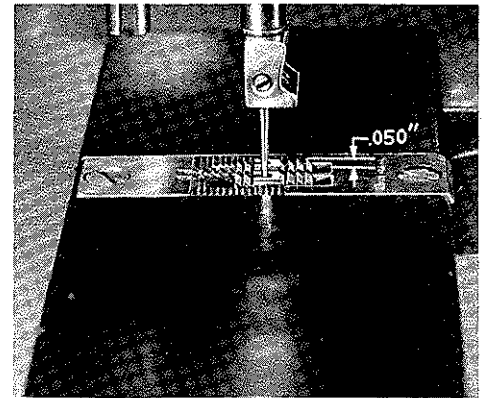

Fig. 15

ADJUSTING THE HOOK OPENER FINGER

Place the opener finger (A, Fig. 17) in the machine. Turn the handwheel in the operating direction until the finger is at its maximum point of travel from the needle. While in this position, the opener finger should be moved tightly against the hook basket (E). Loosen screw (C) to make this adjustment. The opener finger should contact the cam surface on the basket for a length of 1/16 inch.

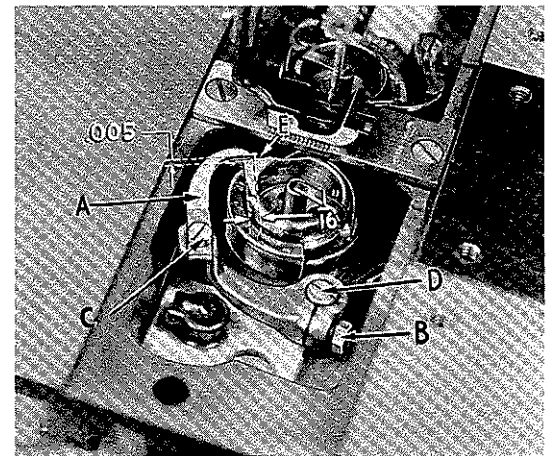

Fig. 17

CHECK SPRING ADJUSTMENT

The take-up spring barrel (A, Fig. 19), which controls the needle thread should be set so that the lower spring stop is at the 9 o'clock position as shown (B, Fig. 19). Loosen screw (C) and turn barrel (A) immediately behind locknut (D) to make this adjustment. This recommended position for the barrel should be approximately correct for first sewing trials. Ultimately, the take-up spring barrel should be adjusted so that there is about $\frac{1}{16}$ to $\frac{1}{8}$ inch movement of the check spring (E) as the needle thread passes around the 6 o'clock position of the hook.

Test check spring tension (E). There should be enough tension to insure a good returning snap when spring is raised and released. The take-up spring adjusting screw (F) may be set so that the head slot slants from the 10 to 4 o'clock position for first sewing trials. This adjustment is made from the take-up pressure screw (F) position of no pressure, and turning the screw counterclockwise to above suggested position. Maintain this adjustment with locknut (D). Final check spring pressure adjustment will depend upon weight and type of thread and weight of fabric.

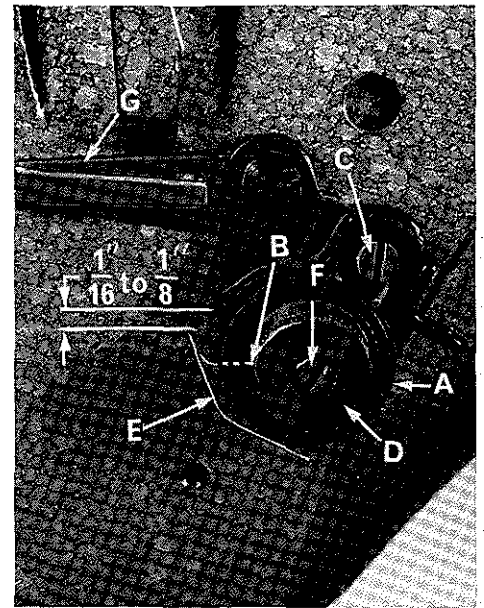

Fig. 19

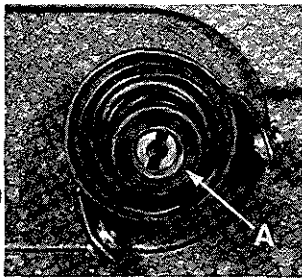

Fig. 20

POSITIONING OF THE FRONT EYELET

Set the front frame needle thread eyelet (G, Fig. 19) in its lowest position parallel with the cloth plate.

ADJUSTMENT FOR CONTINUOUS SEWING

By sewing trials, adjust the needle thread tension (A, Fig. 20), check spring pressure, position barrel (A, Fig. 19) and set the stitch length (B, Fig. 12) to required specifications.

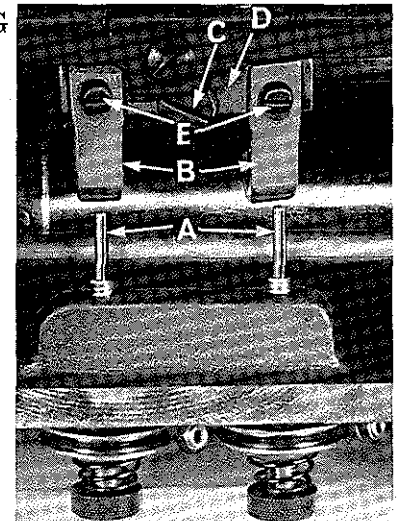

Fig. 21

Machine should sew continuously without thread breakage, circle tack, in line of feed tack, and across the line of feed tack, at all speeds. Styles 62200 L and LA must sew on and off material without thread breakage.

SETTING THE NEEDLE TENSION RELEASE (FOR STYLES 61800 CA, DA, HA, 62200 GA, HA, KA and LA)

The tension release pin (A, Fig. 21) should be centered on the tension release arm (B). This adjustment is made by loosening screw (C) and moving the tension release sleeve (D) right or left as required. Tighten screw

The tension release is to be actuated when the presser foot is raised $\frac{2}{3}$ to $\frac{3}{4}$ of its maximum travel. This is accomplished by loosening screw (C) and rotating the tension release sleeve forward or backward until proper setting has been attained.

The tension release pin (A) should exert only enough pressure to release the thread in the tension discs. This adjustment is made by loosening screw (E) and moving the tension release arm (B) to the rear for less pressure and to the front for more pressure.

NOTE: The setting of the tension release sleeve and the tension release arm should be done together, because if the tension release arm is too far back any rotation of the tension release sleeve will still not give the proper tension release.

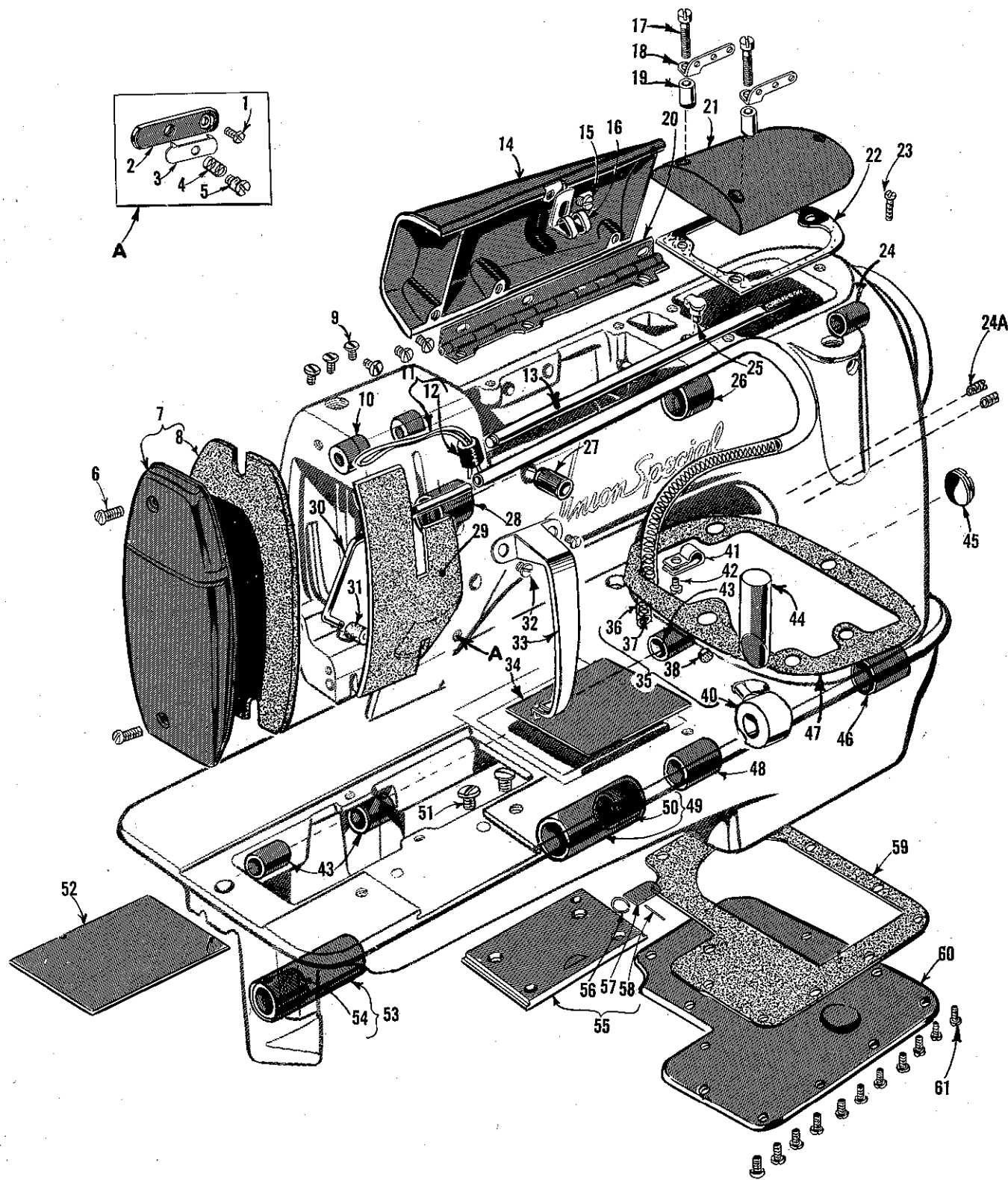

MAIN FRAME BUSHINGS, COVERS, PLATES AND HEAD OILING PARTS

<u>Ref. No.</u>	<u>Part No.</u>	<u>Description</u>	<u>Amt. Req.</u>
1	22564 B	Screw, Needle Thread Nipper Base-----	1
2	62271 F	Needle Thread Nipper Base-----	1
3	57 WB	Nipper Plate -----	1
4	15438 C	Needle Thread Nipper Spring -----	1
5	57 WD	Screw, Nipper Plate -----	1
6	22569	Screw, Head Cover -----	2
7	62282	Head Cover -----	1
8	62282 K	Sound Insulator-----	1
9	22569 D	Screw, Top Cover and Top Cover Hinge-----	6
10	62285 B	Needle Bar Frame Pivot Pin Bushings, for Styles 61800 C, D, H, 62200 G, H, K and L-----	2
	62285 J	Needle Bar Frame Pivot Pin Bushings, for Styles 61800 CA, DA, HA, 62200 GA, HA, KA and LA -----	2
11	666-258	Oil Wick -----	1
12	666-138	Felt -----	1
13	62294	Oil Tube, for Styles 61800 CA, DA, HA, 62200 G, A, HA, KA, and LA -----	1
14	62282 A	Top Cover, hinged -----	1
15	22569 D	Screw, Top Cover Latch -----	1
16	62282 B	Top Cover Latch -----	1
17	294	Screw, Top Cover, right, for Class 61800 -----	1
		Screw, Top Cover, right, for Class 62200 -----	2
18	61271	Needle Thread Lead-in Eyelet, for Class 61800-----	1
		Needle Thread Lead-in Eyelet, for Class 62200-----	2
19	62271 G	Eyelet Mounting Sleeve, for Class 61800 -----	1
		Eyelet Mounting Sleeve, for Class 62200 -----	2
20	62282 C	Top Cover Hinge -----	1
21	62282 D	Top Cover, right -----	1
22	62282 E	Top Cover Gasket, right -----	1
23	22569	Screw, Top Cover, right, for Class 61800 -----	2
	22569	Screw, Top Cover, right, for Class 62200 -----	1
24	62290 B	Main Shaft Bushing -----	1
24A	88	Plug Screw, for synchronizer mounting bracket holes -	2
25	666-117	Oil Cup -----	1
26	62284 A	Needle Feed Rock Shaft Bushing, right -----	1
27	62292 M	Tension Release Pin Bushing, for Styles 61800 C, D, H, 62200 G, H, K and L -----	1
28	62284 B	Needle Feed Rock Shaft Bushing, left -----	1
29	666-257	Head Oil Attraction Felt, for Styles 61800 CA, DA, HA, 62200 GA, HA, KA and LA -----	1
30	62294 A	Oil Siphon Intake Tube, for Styles 61800 CA, DA, HA, 62200 GA, HA, KA and LA -----	1
31	666-256	Oil Siphon Intake Felt, for Styles 61800 CA, DA, HA, 62200 GA, HA, KA and LA -----	1
32	22564	Screw, Take-up Shield, for Styles 61800 CA, DA, HA, 62200 GA, HA, KA and LA -----	2
33	62251 E	Take-up Shield, for Styles 61800 CA, DA, HA, 62200 GA, HA, KA and LA -----	1
34 to 61		See following page	

NOTE: "A", the use of these parts are recommended when sewing with nylon thread.

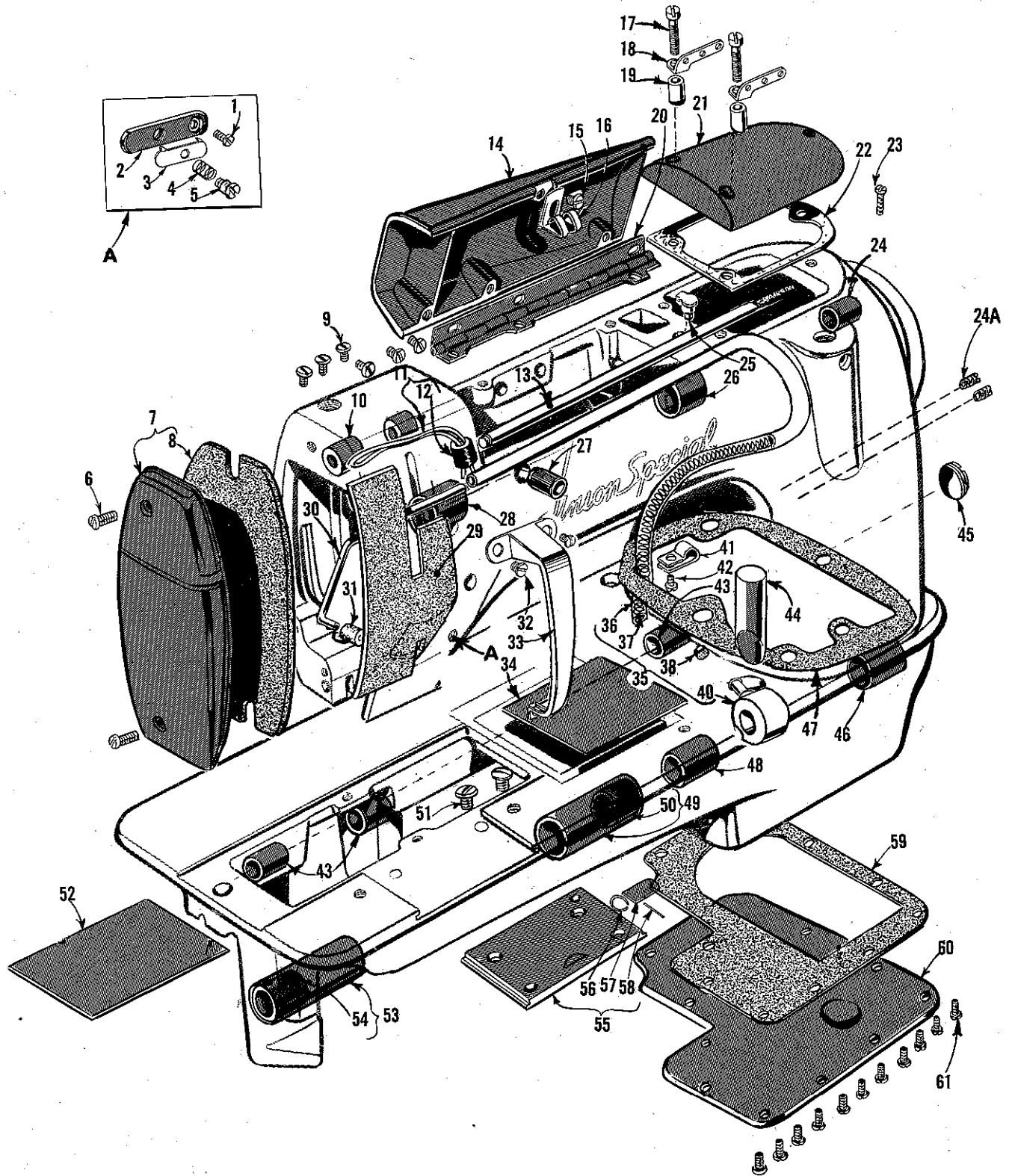

MAIN FRAME BUSHINGS, COVERS, PLATES AND HEAD OILING PARTS

<u>Ref. No.</u>	<u>Part No.</u>	<u>Description</u>	<u>Amt. Req.</u>
1 to 33		See preceding page	
34	62202 G-98	Bed Slide, right, for No. 8 gauge -----	1
	62202 G-97	Bed Slide, right, for No. 12 gauge -----	1
	62202 G-96	Bed Slide, right, for No. 16 gauge -----	1
	62202 G-94	Bed Slide, right, for Nos. 20 and 24 gauges -----	1
	62202 G-92	Bed Slide, right, for Nos. 28 and 32 gauges -----	1
	62202 G-90	Bed Slide, right, for No. 40 gauge -----	1
	62202 G-88	Bed Slide, right, for No. 48 gauge -----	1
	62202 G-86	Bed Slide, right, for No. 56 gauge -----	1
	62202 G-84	Bed Slide, right, for No. 64 gauge -----	1
	62202 G-80	Bed Slide, right, for No. 80 gauge -----	1
	62202 G-76	Bed Slide, right, for No. 96 gauge -----	1
35	61893	Head Oil Pump Assembly, for Styles 61800 CA, DA, HA, 62200 GA, HA, KA and LA -----	1
36	62294 C	Oil Tube -----	1
37	61893 A	Oil Tube Spring -----	1
38	56393 G	Porex Filter -----	1
40	56393	Head Oil Pump -----	1
41	660-356	Oil Tube Clamp, for Styles 61800 CA, DA, HA, 62200 GA, HA, KA and LA -----	1
42	22849 A	Screw, Oil Tube Clamp, for Styles 61800 CA, DA, HA, 62200 GA, HA, KA and LA -----	1
43	62236 C	Feed Rocker Rock Shaft Bushing -----	3
44	50-568 Blk.	Oil Sight Gauge -----	1
45	22539 D	Plug Screw, Feed Rocker Rock Shaft Hole -----	1
46	62232 B	Lower Main Shaft Bushing, right -----	1
47	61882	Shim and Oil Seal Gasket -----	1
48	62232 F	Lower Main Shaft Bushing, inner right -----	1
49	62232 D	Lower Main Shaft Bushing Sleeve, right -----	1
50	62232 A	Lower Main Shaft Bushing -----	1
51	25 C	Screw, Bed Slide, front, and Attachments -----	2
52	62202 F-125	Bed Slide, left, for No. 8 gauge Class 62200 -----	1
	62202 F-124	Bed Slide, left, for Class 61800 and No. 12 gauge Class 62200 -----	1
	62202 F-123	Bed Slide, left, for No. 16 gauge -----	1
	62202 F-122	Bed Slide, left, for No. 20 gauge -----	1
	62202 F-121	Bed Slide, left, for No. 24 gauge -----	1
	62202 F-120	Bed Slide, left, for No. 28 gauge -----	1
	62202 F-119	Bed Slide, left, for No. 32 gauge -----	1
	62202 F-117	Bed Slide, left, for No. 40 gauge -----	1
	62202 F-115	Bed Slide, left, for No. 48 gauge -----	1
	62202 F-113	Bed Slide, left, for No. 56 gauge -----	1
	62202 F-111	Bed Slide, left, for No. 64 gauge -----	1
	62202 F-107	Bed Slide, left, for No. 80 gauge -----	1
	62202 F-103	Bed Slide, left, for No. 96 gauge -----	1
53	62232 C	Lower Main Shaft Bushing Sleeve, left -----	1
54	62232 A	Lower Main Shaft Bushing -----	1
55	62202 N	Bed Slide, front, for all Styles in Class 61800 and 62200 except Style 62200 K -----	1
56	62202 T	Friction Spring, Bed Slide, front -----	1
57	62202 R	Friction Slide, Bed Slide, front -----	1
58	62202 S	Retaining Spring, Bed Slide, front -----	1
59	62282 G	Gasket, Bottom Cover -----	1
60	62282 F	Bottom Cover -----	1
61	22569 C	Screws, Bottom Cover -----	11

NOTE: "A", the use of these parts are recommended when sewing with nylon thread.

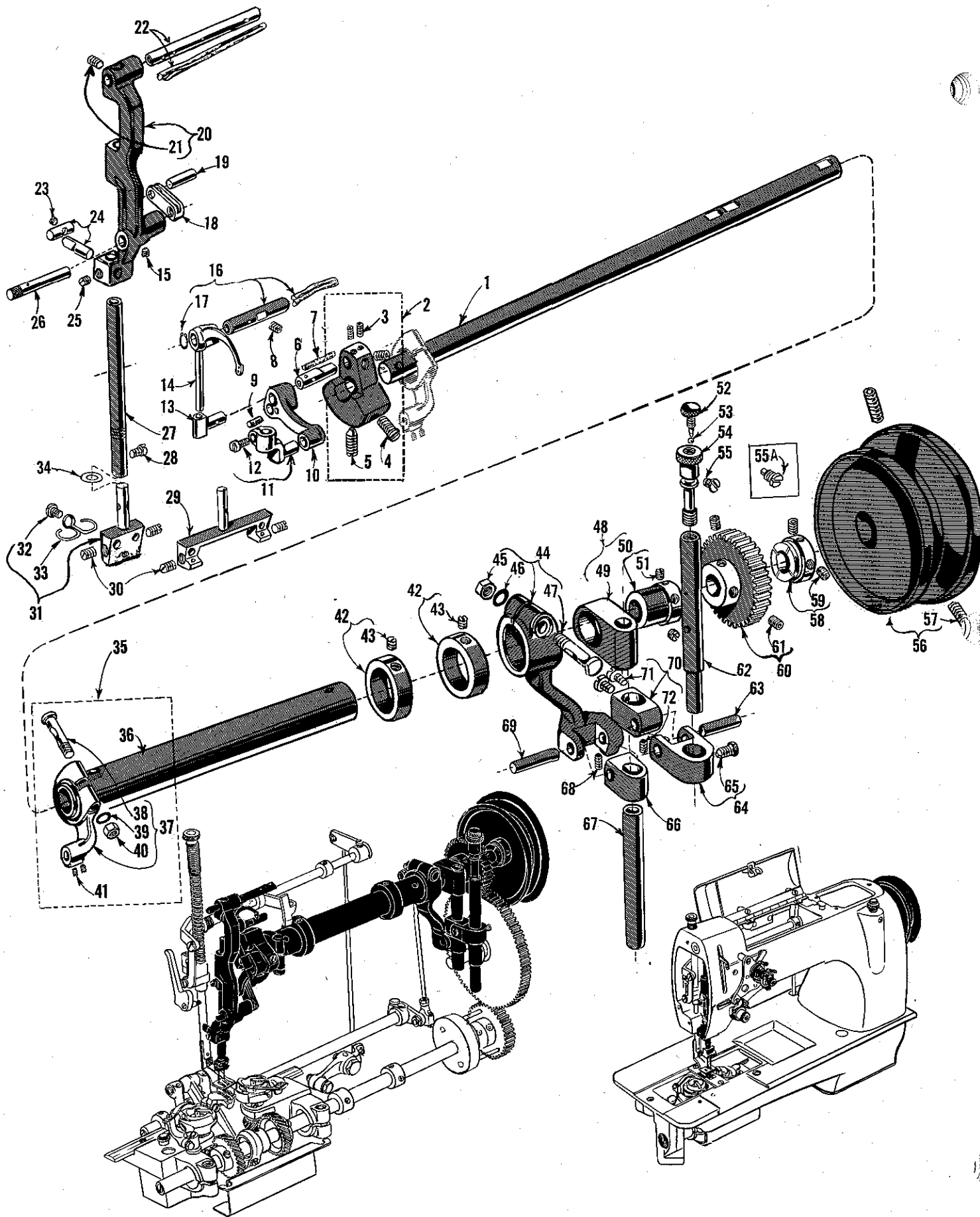

UPPER MAIN SHAFT, NEEDLE FEED DRIVE AND STITCH REGULATING MECHANISM

Ref. No.	Part No.	Description	Amt. Req.
1	62222	Upper Main Shaft -----	1
2	62291 A	Main Shaft Crank and Counterweight -----	1
3	22894 C	Set Screw, Main Shaft Crank -----	3
4	22884 A	Set Screw, Main Shaft Crank -----	1
5	22894 AC	Spot Screw, Main Shaft Crank -----	1
6	62252 A	Crank Pin -----	1
7	666-137	Oil Wick, Crank Pin -----	1
8	22533	Screw, Take-up Lever Stud -----	1
9	666-113	Oil Wick, Needle Bar Connection Stud -----	1
10	62255 E	Needle Bar Driving Link -----	1
11	62255 D	Needle Bar Connecting Stud -----	1
12	22596 D	Screw, Needle Bar Connection Stud -----	1
13	62251 A	Take-up Lever Sleeve -----	1
14	62251 C	Take-up Lever -----	1
15	89	Screw, Needle Bar Frame Rocking Link Pin, front -----	1
16	62251 B	Take-up Lever Stud -----	1
17	660-208	Retaining Ring, Take-up Lever Stud -----	1
18	62285 C	Needle Bar Frame Rocking Link -----	1
19	62285 E	Needle Bar Frame Rocking Link Pin, rear -----	1
20	62285	Needle Bar Frame -----	1
21	78	Screw, Needle Bar Frame Pivot Pin -----	1
22	62285 A	Needle Bar Frame Pivot Pin -----	1
23	22565 B	Screw, Needle Bar Frame Guide and Stud -----	1
24	62285 H	Needle Bar Frame Guide and Stud -----	1
25	95	Screw, Needle Bar Frame Guide and Stud -----	1
26	62285 D	Needle Bar Frame Rocking Link Pin, front -----	1
27	62217 A	Needle Bar, marked "CW", for Class 62200 -----	1
28	22845 H	Holding Screw, Needle Bar Head, for Class 62200 -----	1
29	62218 A	Needle Bar Head, for gauge 40 thru 96 (specify gauge) -----	1
30	22743	Holding Screw, Needles -----	2
31	62218 A	Needle Bar Head, for gauges 8 thru 32 (specify gauge) -----	1
32	22798 B	Screw -----	1
33	62271 K	Needle Holder Eyelet, for Nos. 12 and 16 gauges -----	1
	62271 L	Needle Holder Eyelet, for gauge Nos. 20 thru 32 -----	1
34	66218 W-033	Needle Holder Washer, for Class 62200, .033 inch thick -----	as required
-	62218 W-035	Needle Holder Washer, for Class 62200, .035 inch thick -----	as required
-	62218 W-037	Needle Holder Washer, for Class 62200, .037 inch thick -----	as required
-	62218 W-039	Needle Holder Washer, for Class 62200, .039 inch thick -----	as required
35	29475 X	Needle Feed Rock Shaft and Lever Assembly -----	1
36	62284 E	Needle Feed Rock Shaft -----	1
37	62284 C	Needle Feed Rock Shaft Lever -----	1
38	62283 F	Screw, Needle Feed Rock Shaft Lever -----	1
39	6042 A	Washer, Needle Feed Rock Shaft Lever -----	1
40	55235 E	Nut, Needle Feed Rock Shaft Lever -----	1
41	22565 C	Screw, Needle Feed Rock Shaft Lever -----	2
42	62284 D	Needle Feed Rock Shaft Locking Collar -----	2
43	95	Screw, Locking Collar -----	1
44	62283 L	Feed Driving Lever -----	1
45	55235 E	Nut, Feed Driving Lever -----	1
46	6042 A	Washer, Feed Driving Lever -----	1
47	62283 F	Screw, Feed Driving Lever -----	1
48	29126 BF	Feed Driving Eccentric Assembly -----	1
49	62283 A	Bearing, Feed Driving Eccentric Assembly -----	1
50	62283 J	Eccentric, Feed Driving Eccentric Assembly, .150 inch throw -----	1
51	95	Screw, Feed Driving Eccentric -----	2
52	62245 A	Stitch Regulating Stud Locking Screw, for Styles 61800 C, D, H, 62200 G, H, K and L -----	1
53	28619	Locking Ball, Stitch Regulating Stud, for Styles 61800 C, D, H, 62200 G, H, K and L -----	1
54	62245	Stitch Regulating Stud -----	1
55	62245 B	Locating Stud, Stitch Regulating Stud, for Styles 61800 C, D, H, 62200 G, H, K and L -----	1
55 A	62245 C	Locating Stud, Stitch Regulating Stud, for Styles 61800 CA, DA, HA, 62200 GA, HA, KA, LA -----	1
56	62221 C	Handwheel, #1 Vee or Round Belt -----	1
57	22894 G	Screw, Handwheel -----	2
58	62221 A	Thrust Collar -----	1
59	22894 F	Screw, Thrust Collar -----	2
60	62260	Feed Driving Gear, upper -----	1
61	22894 F	Set Screw, Feed Driving Gear, upper -----	2
62	62246	Stitch Regulating Shaft -----	1
63	62283 D	Pin, Stitch Regulating Shaft Connection -----	1
64	62246 A	Stitch Regulating Shaft Connection -----	1
65	22882 B	Screw, Stitch Regulating Shaft Connection -----	1
66	62283 G	Feed Driving Lever Guide, lower -----	1
67	62283 E	Feed Driving Lever Guide Shaft -----	1
68	22560 A	Screw, Feed Driving Lever Guide Link Pin -----	1
69	62283 H	Feed Driving Lever Guide Link Pin -----	1
70	62283 C	Feed Driving Lever Guide, upper -----	1
71	22570 A	Screw, Feed Driving Lever Guide, upper -----	2
72	531	Screw, Feed Driving Lever Guide, upper -----	1

NOTE: Detail number 32 and 33 are included with detail number 31 on all gauges except No. 8 gauge.

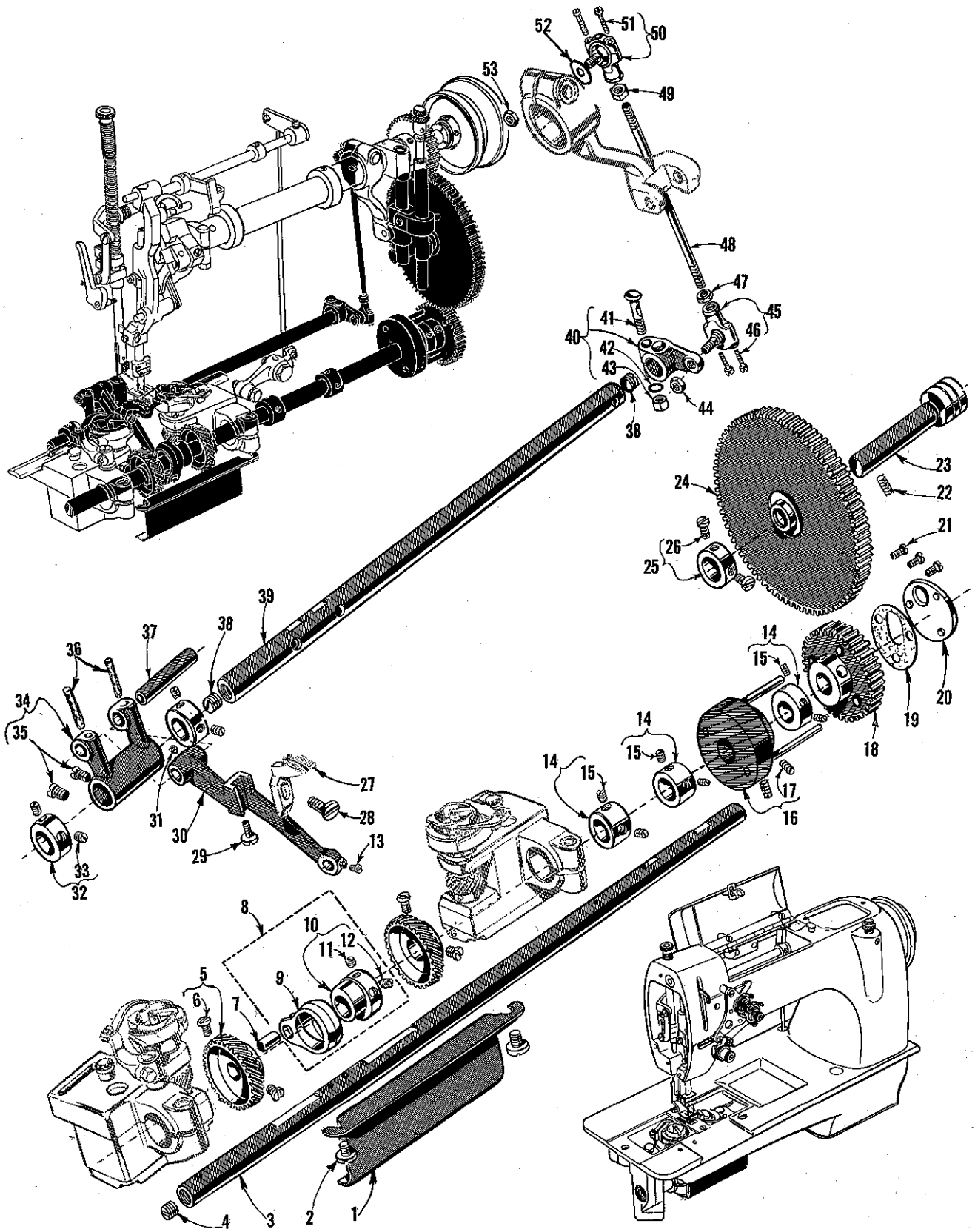

LOWER FEED DRIVING AND HOOK DRIVING PARTS

<u>Ref. No.</u>	<u>Part No.</u>	<u>Description</u>	<u>Amt. Req.</u>
1	62243 A	Hook Shaft Driving Gear Guard -----	1
2	25 S	Screw, Hook Shaft Driving Gear Guard -----	2
3	62232 G	Feed Driving Shaft -----	1
4	22706 A	Screw, Feed Driving Shaft -----	1
5	62243 E	Hook Shaft Driving Gear, for Class 62200 -----	2
-	62243 C	Hook Shaft Driving Gear, for Class 61800 -----	1
6	22839 A	Screw, Hook Shaft Driving Gear -----	2
7	62238 A	Feed Lift Eccentric Link Pin -----	1
8	29126 BL	Feed Lift Eccentric Assembly -----	1
9	62238	Feed Lift Eccentric Bearing -----	1
10	62206	Feed Lift Eccentric -----	1
11	22894 C	Set Screw, Feed Lift Eccentric -----	1
12	22894 D	Spot Screw, Feed Lift Eccentric -----	1
13	22 KH	Screw, Feed Lift Eccentric Link Pin -----	1
14	51147	Collar, Lower Main Shaft -----	3
15	95	Screw, Collar, Lower Main Shaft -----	2
16	62260 H	Lower Main Shaft Driving Gear Coupling -----	1
17	22894 F	Set Screw, Coupling -----	2
18	62260 G	Main Shaft Driving Gear -----	1
19	62282 J	Gasket, Lower Main Shaft Hole Cover Plate -----	1
20	62282 H	Lower Main Shaft Hole Cover Plate -----	1
21	22569 C	Screw, Lower Main Shaft Hole Cover Plate -----	3
22	22597 A	Set Screw, Intermediate Gear Shaft -----	1
23	62262	Intermediate Gear Shaft -----	1
24	62261	Intermediate Gear -----	1
25	61264 A	Collar, Intermediate Gear Shaft -----	1
26	HA61 D	Screw, Collar, Intermediate Gear Shaft -----	2
27		Feed Dog (See Pages 29, 31, 33) -----	1
28	9663	Screw, Feed Dog -----	1
29	22775 A	Screw, Feed Dog Height Adjustment -----	1
30	62234	Feed Bar -----	1
31	89	Screw -----	1
32	62236 D	Collar, Feed Rocker Rock Shaft -----	2
33	95	Screw, Collar, Feed Rocker Rock Shaft -----	2
34	62236	Feed Rocker -----	1
35	22866 G	Screw, Feed Rocker -----	2
36	666-115	Oil Wick -----	2
37	63435 A	Feed Bar Shaft -----	1
38	22706 A	Screw, Feed Rocker Rock Shaft -----	2
39	62236 A	Feed Rocker Rock Shaft -----	1
40	62236 F	Feed Rocker Rock Shaft Driving Arm -----	1
41	55235 D	Locking Stud, Driving Arm -----	1
42	6042 A	Washer, Driving Arm -----	1
43	55235 E	Nut, Driving Arm -----	1
44	18	Nut, Ball Joint Feed Driving Connection, lower -----	1
45	51241 D	Ball Joint Feed Driving Connection, lower -----	1
46	22729 C	Screw, Ball Joint Connection -----	2
47	269	Nut, Feed Driving Connecting Rod -----	1
48	HS35 E	Feed Driving Connecting Rod -----	1
49	18	Nut, Feed Driving Connecting Rod -----	1
50	51239 L	Ball Joint Feed Driving Connection, upper -----	1
51	22729 C	Screw, Ball Joint Connection -----	2
52	51242 M	Washer, Ball Joint Feed Driving Connection, upper -----	1
53	18	Nut, Ball Joint Feed Driving Connection, upper -----	1

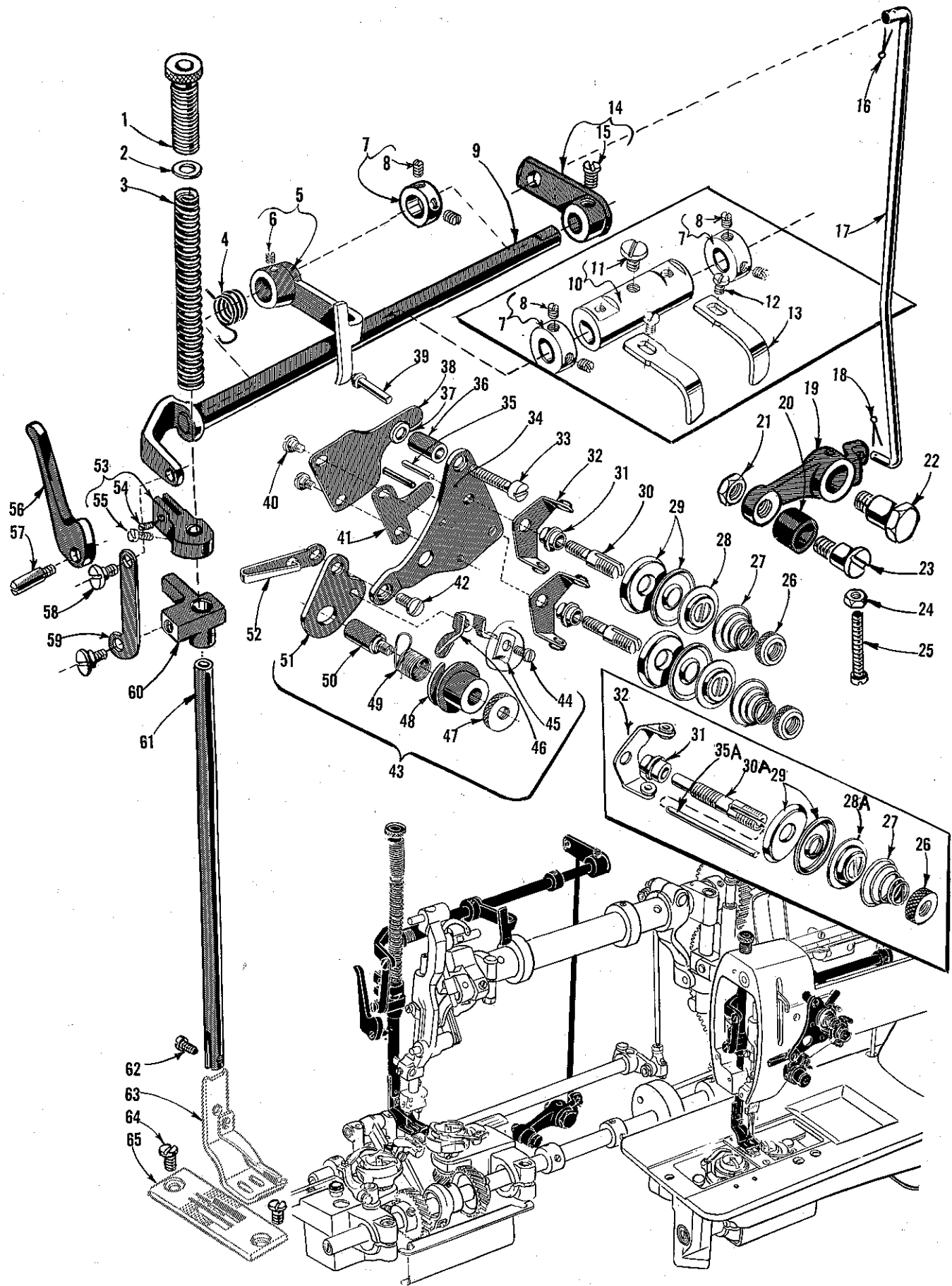

PRESSER BAR, FOOT LIFT AND TENSION RELEASE PARTS

Ref. No.	Part No.	Description	Amt. Req.
1	61257 G	Presser Spring Regulator and Presser Bar Bushing, upper -----	1
2	61256 G	Washer, Presser Bar Bushing, upper -----	1
3	62256	Presser Spring -----	1
4	62268 A	Presser Foot Lifter Shaft Spring-----	1
5	62292 K	Tension Release Arm, for Styles 61800 C, D, H, 62200 G, H, K and L -----	1
6	22894 W	Screw, Tension Release Arm -----	1
7	61248 H	Stitch Regulator Shaft Collar, for Styles 61800 C, D, H, 62200 G, H, K and L -----	1
-	61248 H	Stitch Regulator Shaft Collar, for Styles 61800 CA, DA, HA, 62200 GA, HA, KA, LA -----	2
8	88	Screw, Stitch Regulator Shaft Collar -----	2
9	62268	Presser Foot Lifter Shaft -----	1
10	62292 V	Tension Release Sleeve, for Styles 61800 CA, DA, HA, 62200 GA, HA, KA and LA -----	1
11	88 D	Screw, Tension Release Sleeve -----	1
12	22585 C	Screw, Tension Release Arm -----	1 or 2
13	62292 W	Tension Release Arm, for Styles 61800 CA, DA, HA, 62200 GA, HA, KA and LA -----	1 or 2
14	62268 H	Presser Foot Lifter Lever -----	1
15	22884	Screw, Presser Foot Lifter Lever -----	1
16	660-142	Cotter Pin, upper, Presser Foot Lifter Rod -----	1
17	62268 J	Presser Foot Lifter Rod -----	1
18	660-142	Cotter Pin, lower, Presser Foot Lifter Rod -----	1
19	62268 F	Presser Foot Lifter Lever Bell Crank -----	1
20	62268 G	Presser Foot Lifter Lever Bell Crank Roller -----	1
21	11635 B	Nut, Presser Foot Lifter Lever Bell Crank Roller -----	1
22	22817 C	Screw, Presser Foot Lifter Lever Bell Crank -----	1
23	22712 A	Screw, Presser Foot Lifter Lever Bell Crank Roller -----	1
24	9937	Lock Nut, Presser Foot Lifter Lever Bell Crank -----	1
25	22874	Adjusting Screw, Presser Foot Lifter Lever Bell Crank -----	1
26	61292 C	Tension Post Nut -----	1 or 2
27	61392 F-9	Needle Thread Tension Spring -----	1 or 2
28	61292 H	Tension Release Washer, for Styles 61800 C, D, H, 62200 G, H, K and L -----	1 or 2
28 A	61492 H	Tension Release Washer, for Styles 61800 CA, DA, HA, 62200 GA, HA, KA and LA -----	1 or 2
29	109	Tension Disc -----	2 or 4
30	62292 S	Tension Post, for Styles 61800 C, D, H, 62200 G, H, K and L -----	1 or 2
30 A	62292 U	Tension Post, for Styles 61800 CA, DA, HA, 62200 GA, HA, KA and LA -----	1 or 2
31	51292 A	Tension Post Ferrule -----	1 or 2
32	51292 D	Tension Post Thread Eyelet -----	1 or 2
33	294	Screw, Tension Post Bracket, for Styles 61800 C, D, H, 62200 G, H, K and L -----	1
34	62292 J	Tension Post Bracket, for Styles 61800 C, D, H, 62200 G, H, K and L -----	1
35	62292 C	Tension Release Pin, for Styles 61800 C, D, H, 62200 G, H, K and L -----	1 or 2
35 A	62292 T	Tension Release Pin, for Styles 61800 CA, DA, HA, 62200 GA, HA, KA and LA -----	1 or 2
36	62292 P	Spacing Sleeve, for Styles 61800 C, D, H, 62200 G, H, K and L -----	1
37	51235 G	Spacer Washer, Spacing Sleeve, for Styles 61800 C, D, H, 62200 G, H, K and L -----	if required
38	62292 L	Tension Disc Lifter, for Styles 61800 C, D, H, 62200 G, H, K and L -----	1
39	62292 N	Tension Release Pin, for Styles 61800 C, D, H, 62200 G, H, K and L -----	1
40	22760	Screw, Tension Disc Lifter, for Styles 61800 C, D, H, 62200 G, H, K and L -----	2
41	62292 R	Tension Disc Lifter Spring, for Styles 61800 C, D, H, 62200 G, H, K and L -----	1
42	22569 C	Screw, Needle Thread Guide -----	1
43	29475 AL	Check Spring Assembly -----	1
44	22562	Screw, Thread Eyelet -----	1
45	62253 H	Barrel Clamp -----	1
46	62253 E	Thread Eyelet -----	1
47	62253 K	Lock Nut -----	1
48	62253 L	Check Spring Barrel -----	1
49	62253 D	Check Spring -----	1
50	62253 J	Screw Stud -----	1
51	62253 F	Mounting Plate -----	1
52	62271 C	Needle Thread Guide -----	1
53	62259	Presser Bar Guide -----	1
54	77 Q	Screw -----	1
55	93 A	Screw -----	1
56	61265	Hand Lifter -----	1
57	22799 M	Screw, Hand Lifter -----	1
58	22758 B	Screw, Presser Foot Lifter Link -----	2
59	62268 E	Presser Foot Lifter Link -----	1
60	62258	Presser Bar Connection -----	1
61	62257 A	Presser Bar -----	1
62	22726 L	Screw, Presser Foot -----	1
63		Presser Foot (See Pages 29, 31, 35) -----	1
64	22569 F	Screw, Throat Plate -----	2
65		Throat Plate (See Pages 29, 31, 33) -----	1

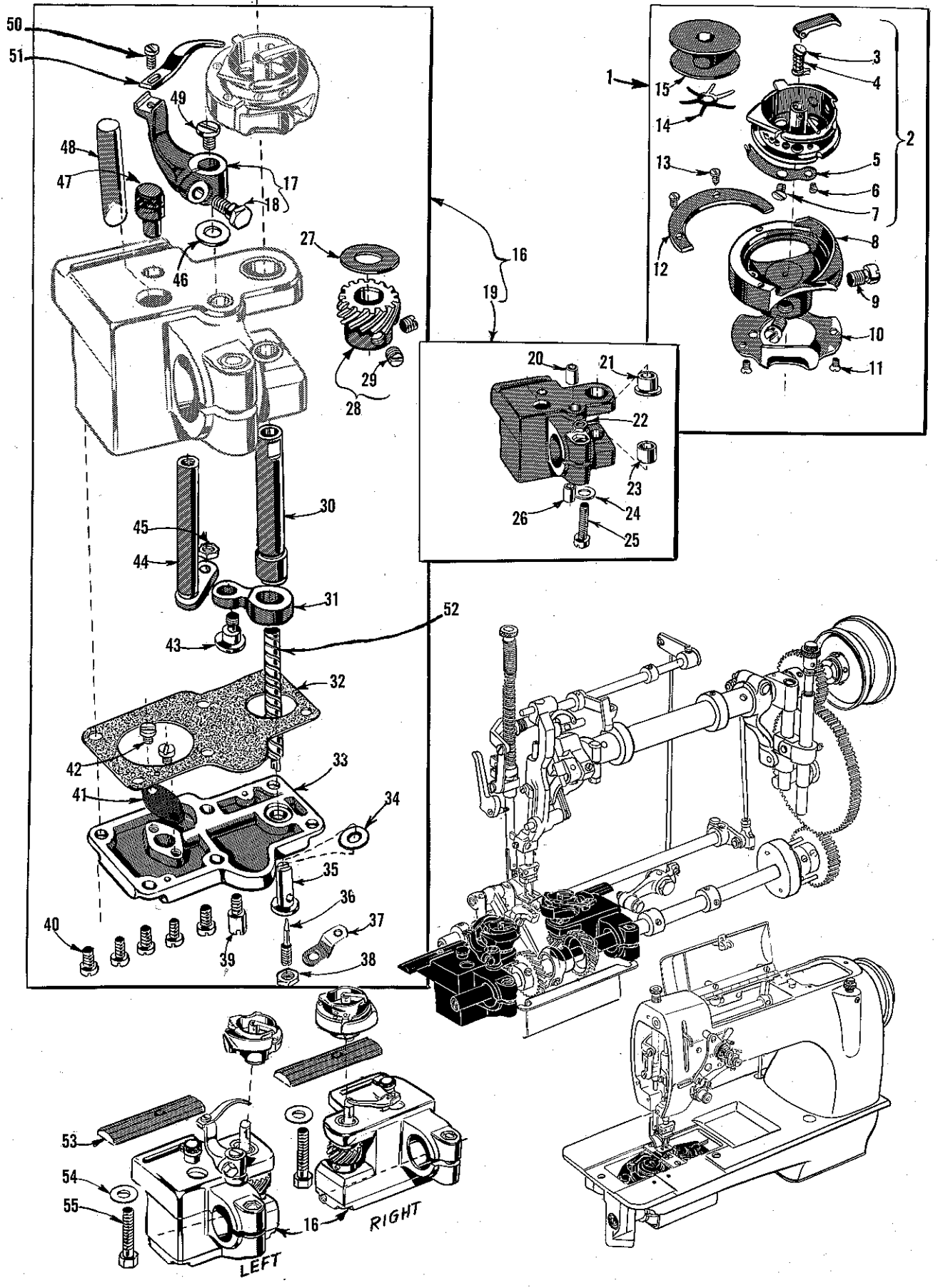

HOOK, HOOK DRIVING AND LUBRICATING PARTS

Ref. No.	Part No.	Description	Amt. Req.
1	29474 H	Vertical Hook Assembly, for Styles 61800 C, D, CA, DA, 62200 G, K, L, GA, KA and LA -----	1 or 2
	29474 K	Vertical Hook Assembly, for Styles 61800 H, HA, 62200 H and HA ----	1 or 2
2	62214	Bobbin Case Assembly -----	1
3	62215 C	Latch Pressure Pin -----	1
4	62215 B	Latch Spring -----	1
5	62214 J	Thread Tension Spring -----	1
6	22716 F	Screw -----	1
7	22716 E	Screw -----	1
8	62208 A	Hook, for No. 29474 H assembly -----	1
	62208 C	Hook, for No. 29474 K assembly -----	1
9	72	Screw -----	2
10	62210	Needle Guard -----	1
11	22716 A	Screw -----	2
12	62214 D	Bobbin Case Retainer, marked "B", for No. 29474 H assembly ---	1
	62214 K	Bobbin Case Retainer, marked "C", for No. 29474 K assembly ---	1
13	22716 G	Screw -----	2
14	62212 B	Bobbin Brake Spring, for No. 29474 K assembly -----	1
15	62212	Bobbin -----	1
16	29480 AT	Hook Shaft Mounting Bracket and Oil Reservoir Assembly, left -----	1
	29480 AU	Hook Shaft Mounting Bracket and Oil Reservoir Assembly, right -----	1
17	62242 A	Bobbin Case Opener Lever -----	1
18	22519 E	Screw -----	1
19	62241	Hook Shaft Mounting Bracket and Oil Reservoir, left -----	1
	62241 A	Hook Shaft Mounting Bracket and Oil Reservoir, right -----	1
20	62242 F	Bushing -----	1
21	62241 H	Bushing, bronze -----	1
22	258 A	Nut -----	1
23	62241 G	Bushing, bronze -----	1
24	6042 A	Washer -----	1
25	820	Screw -----	1
26	62242 G	Bushing -----	1
27	62244 A	Washer -----	1
28	62244	Hook Shaft Pinion -----	1
29	98	Screw -----	2
30	62240	Hook Shaft -----	1
31	62242 D	Bobbin Case Opener Lever Link -----	1
32	62241 C	Gasket, left -----	1
	62241 E	Gasket, right -----	1
33	62241 B	Bottom Cover, left -----	1
	62241 D	Bottom Cover, right -----	1
34	41355 U-8	Shim, .008 inch thick ----- if required	
35	62296 D	Hook Shaft Oil Valve -----	1
36	62296 A	Oil Flow Regulating Screw -----	1
37	62296 C	Lock Washer (not used on later models) -----	1
38	907	Nut -----	1
39	22585 G	Screw (not used on later models) -----	1
40	22585	Screw -----	5
41	62241 F	Oil Filter Screen -----	1
42	T26	Screw -----	2
43	22735 A	Screw -----	1
44	62242 B	Bobbin Case Opener Lever Shaft -----	1
45	12934 A	Nut -----	1
46	61451 C	Washer -----	1
47	666-243	Oil Cup -----	1
48	50-629 Blk.	Oil Sight Gauge -----	1
49	88 D	Screw -----	1
50	J87 J	Screw -----	1 or 2
51	62242	Bobbin Case Opener -----	1 or 2
52	62296 B	Hook Shaft Spiral Oil Feed -----	1 or 2
53	62241 K-168	Rest Plate, .168 inch thick -----	1 or 2
	62241 K-178	Rest Plate, .178 inch thick -----	1 or 2
	62241 K-188	Rest Plate, .188 inch thick -----	1 or 2
	62241 K-198	Rest Plate, .198 inch thick for No. 62241 and 62241 A -----	1 or 2
54	61341 J	Washer -----	1 or 2
55	157	Screw -----	1 or 2

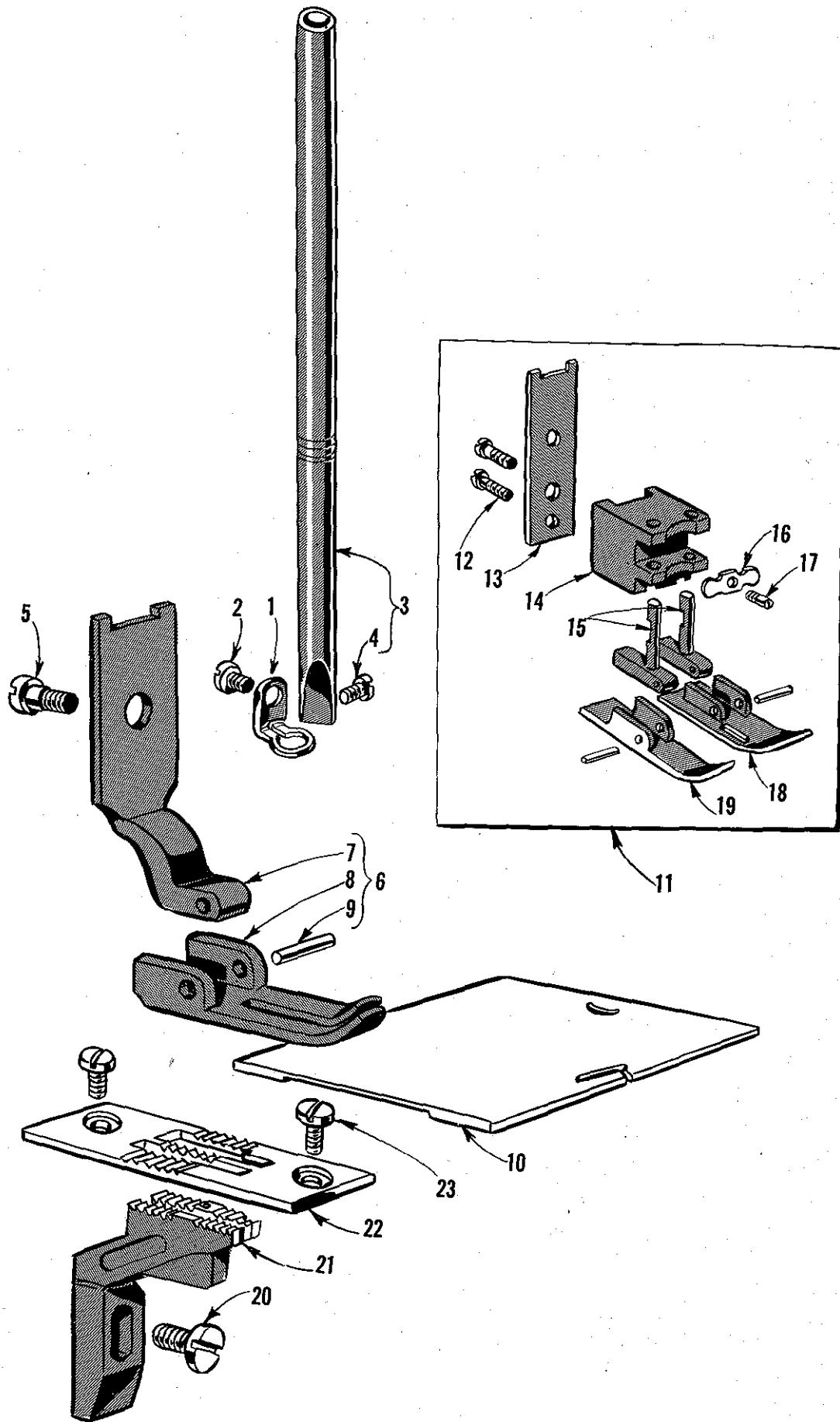

PARTS FOR STYLES IN CLASS 61800

<u>Ref. No.</u>	<u>Part No.</u>	<u>Description</u>	<u>Amt. Req.</u>
1	61871 A	Needle Bar Eyelet, for Styles 61800 C, D, H, CA, DA and HA -----	1
2	187 A	Screw -----	1
3	61817	Needle Bar, for Styles 61800 C, D, H, CA, DA and HA -----	1
4	77 A	Screw -----	1
5	22726 L	Screw, for presser foot -----	1
6	61820 A	Presser Foot, for Styles 61800 C, H, CA and HA -----	1
7	61830	Shank -----	1
8	61830 A	Bottom -----	1
9	61330 B-35	Hinge Pin -----	1
10	61802	Bed Slide, right, for Styles 61800 C, D, H, CA, DA and HA -----	1
	62202 F-124	Bed Slide, left, for Styles 61800 C, D, H, CA, DA and HA -----	1
11	61820 B	Presser Foot, for Styles 61800 D and DA -----	1
12	22797	Screw -----	2
13	61830 G	Shank, vertical section -----	1
14	61830 B	Shank, base section -----	1
15	61830 E	Plunger -----	2
16	61830 F	Equalizer -----	1
17	22799 F	Screw -----	1
18	61830 D	Bottom Section, right -----	1
19	61830 C	Bottom Section, left -----	1
20	9663	Screw -----	1
21	61805 A	Feed Dog, for Styles 61800 C, D, H, CA, DA and HA -----	1
22	61828	Throat Plate, for Styles 61800 C, D, H, CA, DA and HA -----	1
23	22569 F	Screw -----	2

125 thick.

Can also use 61824A same as 61828 but .109 thick

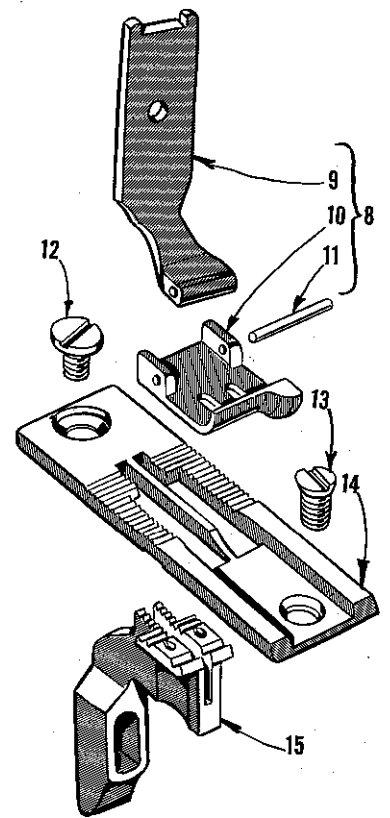
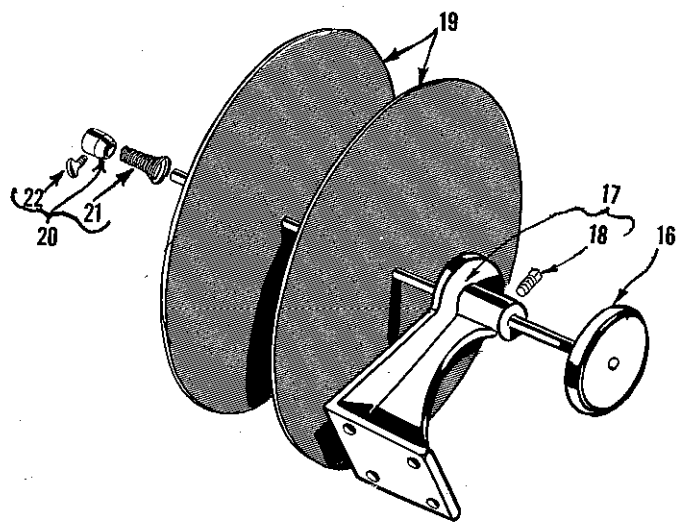
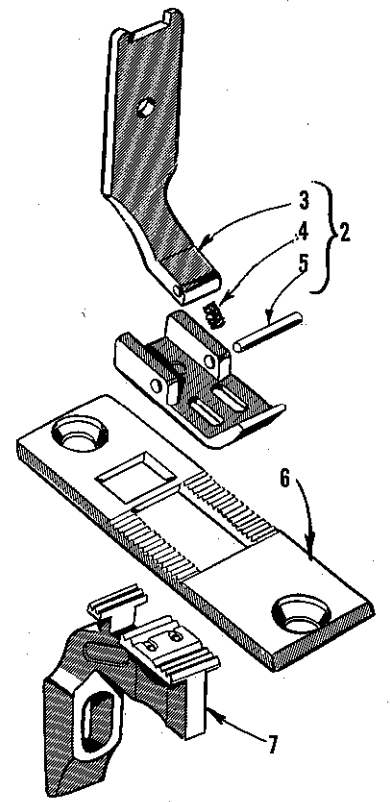
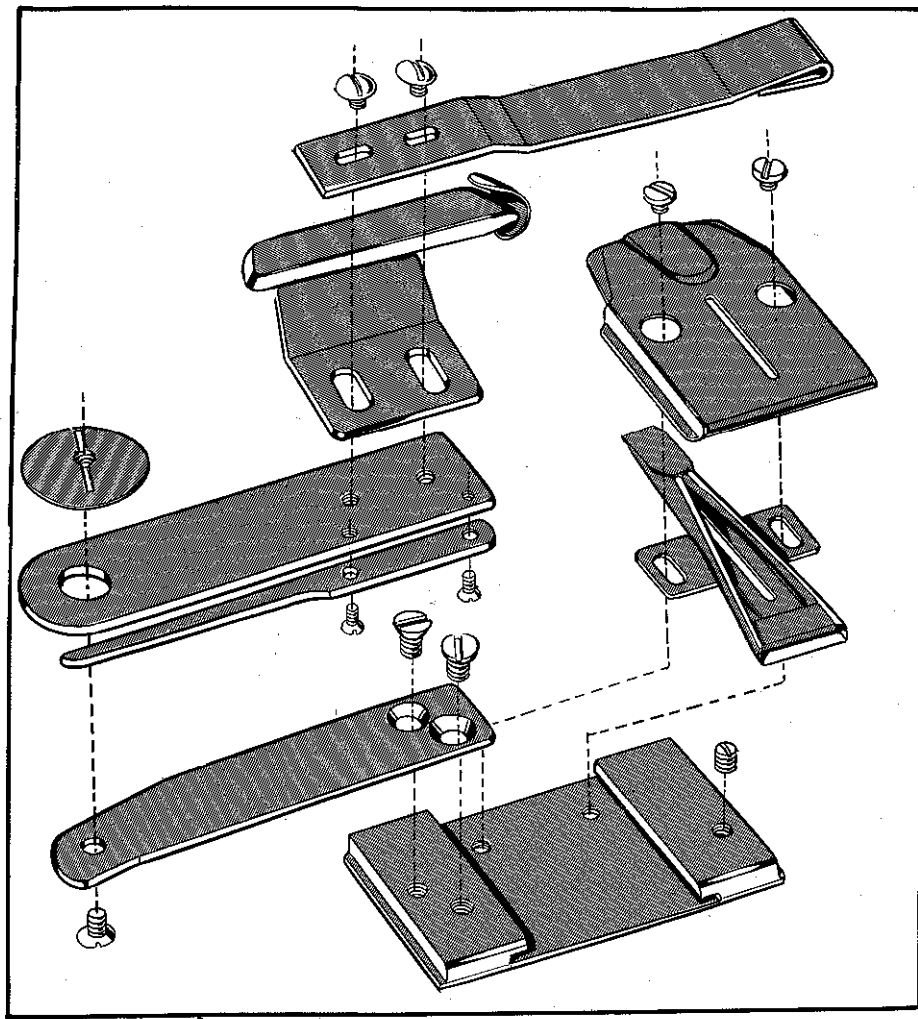

ATTACHMENT, AND COMBINATION OF SEWING PARTS
FOR STYLES 62200 K, L, KA and LA

Ref. No.	Part No.	Description	Amt. Req.
1	23520 A-12	Taping Attachment, for Styles 62200 K and KA -----	1
2	62220 N-12	Presser Foot, for Styles 62200 L and LA -----	1
3	61830	Shank -----	1
4	62230 H	Spring -----	1
5	62230 D-41	Hinge Pin -----	1
6	62228 L-12	Throat Plate, for Styles 62200 L and LA -----	1
7	62205 L-12	Feed Dog, marked "BD", for Styles 62200 L and LA -----	1
8	62220 M-12	Presser Foot, for Styles 62200 K and KA -----	1
9	62230	Shank -----	1
10	62230 T-12	Presser Foot Bottom, marked "R" -----	1
11	62230 D-41	Hinge Pin -----	1
12	22569 F	Screw, Throat Plate, for Styles 62200 K and KA -----	1
-	22569 F	Screw, Throat Plate, for all other styles -----	2
13	22757 E	Screw, Throat Plate, for Styles 62200 K and KA -----	1
14	62228 K-12	Throat Plate, for Styles 62200 K and KA -----	1
15	62205 K-12	Feed Dog, for Styles 62200 K and KA -----	1
16	21385 B	Tape Reel Axle, for Styles 62200 K and KA -----	1
17	201 A	Tape Reel Bracket, for Styles 62200 K and KA -----	1
18	22508	Screw -----	1
19	21178	Tape Reel Disc, for Styles 62200 K and KA -----	2
20	21177 A	Spring Collar, for Styles 62200 K and KA -----	1
21	1349 A-5	Spring -----	1
22	22647 K-24	Thumb Screw -----	1

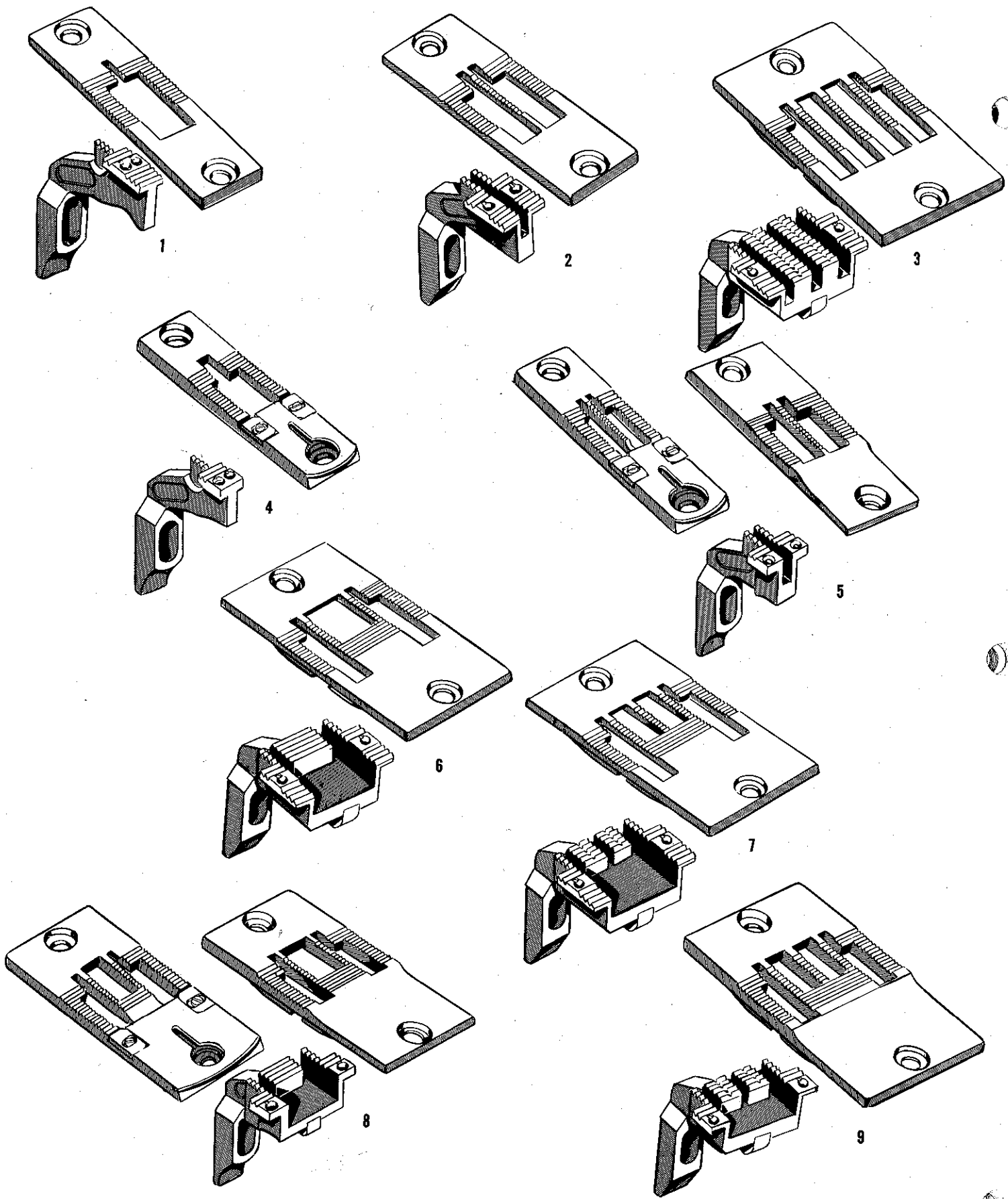

COMBINATIONS OF SEWING PARTS

Minor numbers after the part numbers indicate the gauge or the distance between the needles in 64ths of an inch. Example: 62205 F-16 is a feed dog with 16/64 or 1/4 inch between the needles. The gauge of "K" numbers is shown in parentheses after the part number.

All feed dogs have .082 inch diameter needle holes except those where the number is preceded by a reference mark. Refer to explanation below.

FULL FEED

<u>REFERENCE NO. 1</u>			<u>REFERENCE NO. 2</u>			<u>REFERENCE NO. 3</u>		
<u>FEED DOG</u>	<u>THROAT PLATE, TYPE</u>		<u>FEED DOG</u>	<u>THROAT PLATE, TYPE</u>		<u>FEED DOG</u>	<u>THROAT PLATE, TYPE</u>	
62205 A-8	62228 A-8	Flat	62205 F-12	62228-12	Flat	62205-64	62224-64	Flat
62205 A-12	62228 A-12	Flat	62205 F-16	62228-16	Flat	62205-80	62224-80	Flat
K67352 (10)	K67351 (10)	Flat	62205 F-20	62228-20	Flat	62205-96	62224-96	Flat
+62205 H-12	62228 A-12	Flat	62205 F-24	62224-24	Flat			
			+ 62205 H-16	62228-16	Flat			
			+ 62205 H-20	62228-20	Flat			
			+ 62205 H-24	62224-24	Flat			
			*K67501 (12)	K68439 (12)	Flat			
			*K68375 (20)	62228-20	Flat			
			*K68444 (24)	62224-24	Flat			

HALF FEED

<u>REFERENCE NO. 4</u>			<u>REFERENCE NO. 5</u>		
<u>FEED DOG</u>	<u>THROAT PLATE, TYPE</u>		<u>FEED DOG</u>	<u>THROAT PLATE, TYPE</u>	
*K68441 (8)	K68440 (8)	Tape Slot	62205 B-12	62228 B-12	Tape Slot
			62205 B-16	62224 B-16	Tape Slot
			62205 B-20	62224 B-20	Tape Slot
			*K68445 (12)	62228 B-12	Tape Slot

FULL QUARTER FEED

<u>REFERENCE NO. 6</u>			<u>REFERENCE NO. 7</u>		
<u>FEED DOG</u>	<u>THROAT PLATE, TYPE</u>		<u>FEED DOG</u>	<u>THROAT PLATE, TYPE</u>	
62205 C-28	62224 C-28	Flat	62205 C-64	62224 C-64	Flat
62205 C-32	62224 C-32	Flat	62205 C-80	62224 C-80	Flat
62205 C-40	62224 C-40	Flat	62205 C-96	62224 C-96	Flat
62205 C-48	62224 C-48	Flat			
62205 C-56	62224 C-56	Flat			
+62205 G-28	62224 C-28	Flat			
+62205 G-32	62224 C-32	Flat			

HALF QUARTER FEED

<u>REFERENCE NO. 8</u>			<u>REFERENCE NO. 9</u>		
<u>FEED DOG</u>	<u>THROAT PLATE, TYPE</u>		<u>FEED DOG</u>	<u>THROAT PLATE, TYPE</u>	
62205 D-32	62224 D-32	Raised	62205 D-56	62224 D-56	Raised
62205 D-40	62224 D-40	Raised	62205 D-64	62224 D-64	Raised
62205 D-48	62224 D-48	Raised			
62205 D-28	62224 E-28	Tape Slot			
62205 D-32	62224 E-32	Tape Slot			
62205 D-40	62224 E-40	Tape Slot			
62205 D-48	62224 E-48	Tape Slot			

CHAINING COMB.
 62205 L-16 063 NOL HULL
 62205 N-16 8-12 SPL
 62228 L-16
 62205 N-16 063 NOL HULL
 62205 N-16 11-T-17-SPL
 62228 N-16

* Feed Dog has .063 inch diameter needle hole
 + Feed Dog has .093 inch diameter needle hole

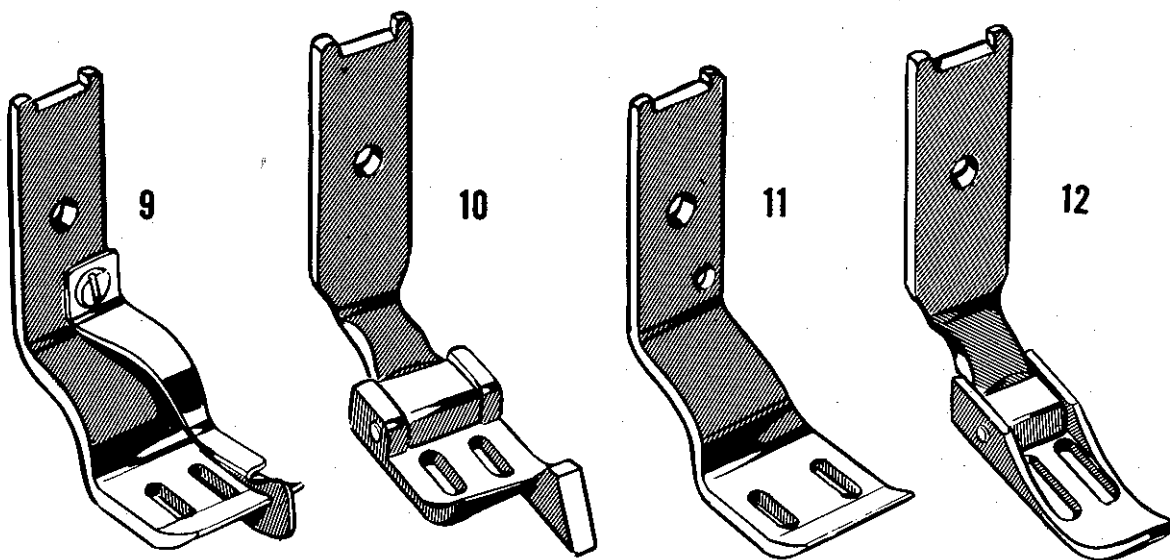
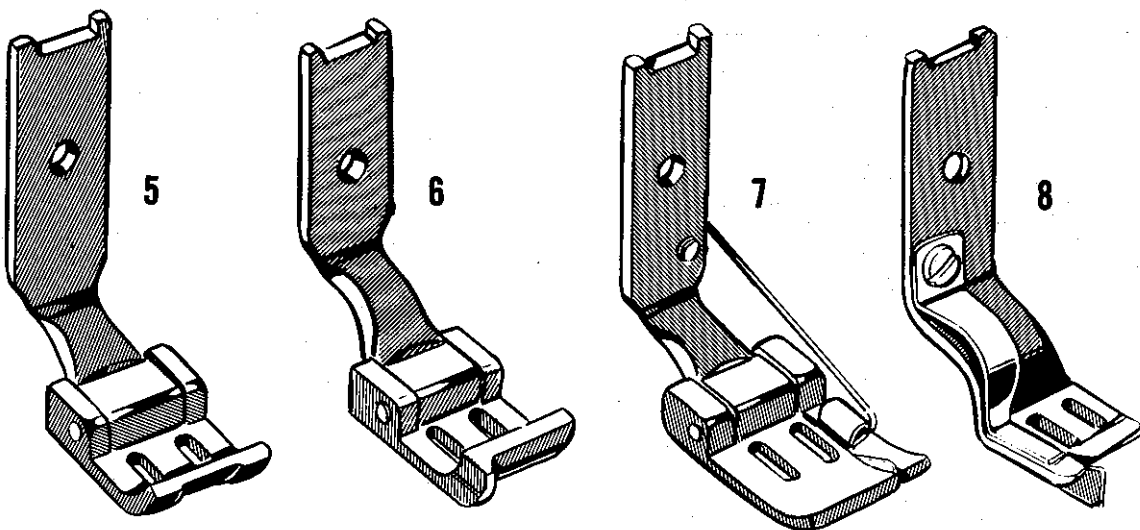
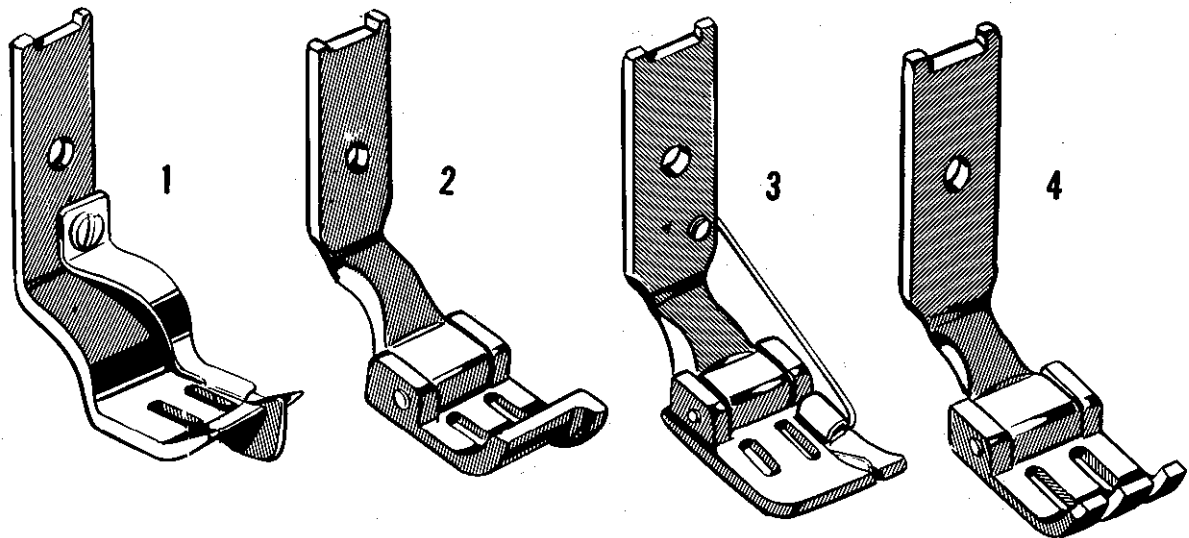

PRESSER FEET

REF. NO.	PART NO.	TYPE	GAUGE	MARGIN	SHANK	BOTTOM	HINGE PIN	TILTING SPRING	SPRING GUIDE	SCREW
1	62220-12	Solid	12	1/16					62230 E-12	605
	62220-16	Solid	16	1/16					62230 E-12	605
2	62220 A-8	Hinged	8		61830	62230 A-8	62230 D-41			
	62220 A-12	Hinged	12		62230	62230 A-12	62230 D-41			
	62220 A-16	Hinged	16		62230	62230 A-16	62230 D-41			
	62220 A-20	Hinged	20		62230	62230 A-20	62230 D-41			
	62220 A-24	Hinged	24		62230	62230 A-24	62230 D-41			
	62220 A-28	Hinged	28		62230	62230 A-28	62230 D-41			
	62220 A-32	Hinged	32		62230	62230 A-32	62230 D-41			
3	62220 C-12	Hinged	12	3/32	62230 F	62230 G-12		62230 H	62230 J	605 A
	62220 C-16	Hinged	16	3/32	62230 F	62230 G-16		62230 H	62230 J	605 A
4	62220 D-12	Hinged	12		62230	62230 K-12	62230 D-41			
	62220 D-16	Hinged	16		62230	62230 K-16	62230 D-41			
	62220 D-20	Hinged	20		62230	62230 K-20	62230 D-41			
	62220 D-24	Hinged	24		62230	62230 K-24	62230 D-41			
	62220 D-28	Hinged	28		62230	62230 K-28	62230 D-41			
	62220 D-32	Hinged	32		62230	62230 K-32	62230 D-41			
	62220 D-40	Hinged	40		62230	62230 K-40	62230 D-41			
	62220 D-48	Hinged	48		62230	62230 K-48	62230 D-41			
	62220 D-56	Hinged	56		62230	62230 K-56	62230 D-41			
	62220 D-64	Hinged	64		62230	62230 K-64	62230 D-41			
	62220 D-80	Hinged	80		62230	62230 K-80	62230 D-41			
	62220 D-96	Hinged	96		62230	62230 K-96	62230 D-41			
5	62220 E-8	Hinged	8		61830	62230 L-8	61330 B-29			
	62220 E-12	Hinged	12		62230	62230 L-12	62230 D-41			
	62220 E-16	Hinged	16		62230	62230 L-16	62230 D-41			
	62220 E-20	Hinged	20		62230	62230 L-20	62230 D-41			
	62220 E-24	Hinged	24		62230	62230 L-24	62230 D-41			
	62220 E-28	Hinged	28		62230	62230 L-28	62230 D-41			
	62220 E-32	Hinged	32		62230	62230 L-32	62230 D-41			
	62220 E-40	Hinged	40		62230	62230 L-40	62230 D-41			
	62220 E-48	Hinged	48		62230	62230 L-48	62230 D-41			
	62220 E-56	Hinged	56		62230	62230 L-56	62230 D-41			
	62220 E-64	Hinged	64		62230	62230 L-64	62230 D-41			
6	62220 F-8	Hinged	8		61830	62230 M-8	61330 B-29			
	62220 F-12	Hinged	12		62230	62230 M-12	62230 D-41			
	62220 F-16	Hinged	16		62230	62230 M-16	62230 D-41			
	62220 F-20	Hinged	20		62230	62230 M-20	62230 D-41			
	62220 F-24	Hinged	24		62230	62230 M-24	62230 D-41			
7	62220 G-8	Hinged	8	1/16	61830	62230 N-8	61330 B-35	62230 H	62230 J	605 A
	62220 G-12	Hinged	12	1/16	62230 F	62230 N-12	62230 D-41	62230 H	62230 J	605 A
	62220 G-16	Hinged	16	1/16	62230 F	62230 N-16	62230 D-41	62230 H	62230 J	605 A
	62220 G-20	Hinged	20	1/16	62230 F	62230 N-20	62230 D-41	62230 H	62230 J	605 A
	62220 G-24	Hinged	24	1/16	62230 F	62230 N-24	62230 D-41	62230 H	62230 J	605 A
	62220 G-28	Hinged	28	1/16	62230 F	62230 N-28	62230 D-41	62230 H	62230 J	605 A
	62220 G-32	Hinged	32	1/16	62230 F	62230 N-32	62230 D-41	62230 H	62230 J	605 A
8	62220 H-12	Solid	12	1/16					62230 R	605
9	62220 J-12	Solid	12	3/32					62230 E-12	605
	62220 J-16	Solid	16	3/32					62230 E-12	605
10	62220 K-16	Hinged	16		62230	62230 S-16	62230 D-41			
11	62220 L-24	Solid	24							
12	62220 P-12	Hinged	12		62230 V	62230 U-12				
	K68360	Hinged	16							

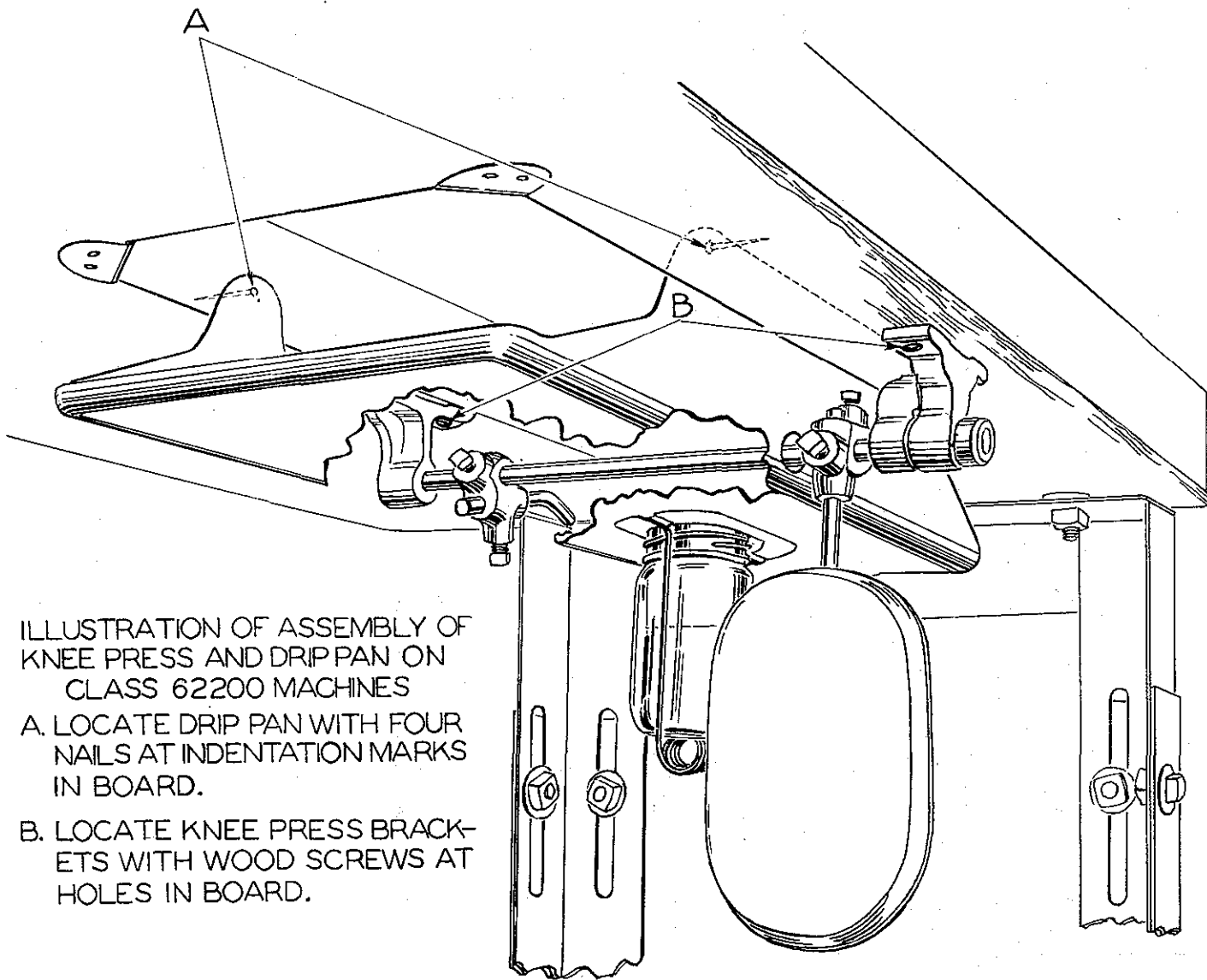

ILLUSTRATION OF ASSEMBLY OF
KNEE PRESS AND DRIP PAN ON
CLASS 62200 MACHINES

- A. LOCATE DRIP PAN WITH FOUR
NAILS AT INDENTATION MARKS
IN BOARD.
- B. LOCATE KNEE PRESS BRACK-
ETS WITH WOOD SCREWS AT
HOLES IN BOARD.

NUMERICAL INDEX OF PARTS

Part No.	Page No.	Part No.	Page No.	Part No.	Page No.
18.....	23	22565 B.....	21	55235 D.....	23
22 KH.....	23	22565 C.....	21	55235 E.....	21, 23
25 C.....	19	22569.....	17	56393.....	19
25 S.....	23	22569 C.....	19, 23, 25	56393 G.....	19
T26.....	27	22569 D.....	17		
HS35 E.....	23	22569 F.....	25, 29, 31	61248 H.....	25
50-568 Blk.....	19	22570 A.....	21	61256 G.....	25
50-629 Blk.....	27	22585.....	27	61257 G.....	25
57 WB.....	17	22585 C.....	25	61264 A.....	23
57 WD.....	17	22585 G.....	27	61265.....	25
HA61 D.....	23	22596 D.....	21	61271.....	17
72.....	27	22597 A.....	23	61292 C.....	25
77 A.....	29	22647 K-24.....	31	61292 H.....	25
77 Q.....	25	22706 A.....	23	61330 B.....	29, 35
78.....	21	22712 A.....	25	61341 J.....	27
J87 J.....	27	22716 A.....	27	61392 F.....	25
88.....	17, 25	22716 E.....	27	61451 C.....	27
88 D.....	25, 27	22716 F.....	27	61492 H.....	25
89.....	21, 23	22716 G.....	27	61802.....	29
93 A.....	25	22726 L.....	25, 29	61805 A.....	29
95.....	21, 23	22729 C.....	23	61817.....	29
98.....	27	22735 A.....	27	61820 A.....	29
109.....	25	22743.....	21	61820 B.....	29
157.....	27	22757 E.....	31	61828.....	29
187 A.....	29	22758 B.....	25	61830.....	29, 31, 35
201 A.....	31	22760.....	25	61830 A.....	29
258 A.....	27	22775 A.....	23	61830 B.....	29
269.....	23	22797.....	29	61830 C.....	29
294.....	17, 25	22798 B.....	21	61830 D.....	29
531.....	21	22799 F.....	29	61830 E.....	29
605.....	35	22799 M.....	25	61830 F.....	29
605 A.....	35	22817 C.....	25	61830 G.....	29
660-142.....	25	22839 A.....	23	61871 A.....	29
660-208.....	21	22845 H.....	21	61882.....	19
660-356.....	19	22849 A.....	19	61893.....	19
666-113.....	21	22866 G.....	23	61893 A.....	19
666-115.....	23	22874.....	25		
666-117.....	17	22882 B.....	21	62202 F.....	19, 29
666-137.....	21	22884.....	25	62202 G.....	19
666-138.....	17	22884 A.....	21	62202 N.....	19
666-243.....	27	22894 C.....	21, 23	62202 R.....	19
666-256.....	17	22894 D.....	23	62202 S.....	19
666-257.....	17	22894 F.....	21, 23	62202 T.....	19
666-258.....	17	22894 G.....	21	62205.....	33
820.....	27	22894 W.....	25	62205 A.....	33
907.....	27	22894 AC.....	21	62205 B.....	33
1349 A-5.....	31	23520 A-12.....	31	62205 C.....	33
6042 A.....	21, 23, 27	28619.....	21	62205 D.....	33
9663.....	23, 29	29126 BL.....	23	62205 F.....	33
9937.....	25	29126 BP.....	21	62205 G.....	33
11635 B.....	25	29474 H.....	27	62205 H.....	33
12934 A.....	27	29474 K.....	27	62205 K.....	31
15438 C.....	17	29475 X.....	21	62205 L.....	31
21177 A.....	31	29475 AL.....	25	62206.....	23
21178.....	31	29480 AT.....	27	62208 A.....	27
21385 B.....	31	29480 AU.....	27	62208 C.....	27
22508.....	31	41355 U-8.....	27	62210.....	27
22519 E.....	27	51147.....	23	62212.....	27
22533.....	21	51235 G.....	25	62212 B.....	27
22539 D.....	19	51239 L.....	23	62214.....	27
22560 A.....	21	51241 D.....	23	62214 D.....	27
22562.....	25	51242 M.....	23	62214 J.....	27
22564.....	17	51292 A.....	25	62214 K.....	27
22564 B.....	17	51292 D.....	25	62215 B.....	27

NOTE: Only the basic part numbers are shown in the index. For various gauges, capacities, etc. available, refer to the listings on pages indicated.

NUMERICAL INDEX OF PARTS

<u>Part No.</u>	<u>Page No.</u>	<u>Part No.</u>	<u>Page No.</u>	<u>Part No.</u>	<u>Page No.</u>
62215 C.....	27	62240.....	27	62282 B.....	17
62217 A.....	21	62241.....	27	62282 C.....	17
62218 A.....	21	62241 A.....	27	62282 D.....	17
62218 W.....	21	62241 B.....	27	62282 E.....	17
62220.....	35	62241 C.....	27	62282 F.....	19
62220 A.....	35	62241 D.....	27	62282 G.....	19
62220 C.....	35	62241 E.....	27	62282 H.....	23
62220 D.....	35	62241 F.....	27	62282 J.....	23
62220 E.....	35	62241 G.....	27	62282 K.....	17
62220 F.....	35	62241 H.....	27	62283 A.....	21
62220 G.....	35	62241 K.....	27	62283 C.....	21
62220 H.....	35	62242.....	27	62283 D.....	21
62220 J.....	35	62242 A.....	27	62283 E.....	21
62220 K.....	35	62242 B.....	27	62283 F.....	21
62220 L.....	35	62242 D.....	27	62283 G.....	21
62220 M.....	31	62242 F.....	27	62283 H.....	21
62220 N.....	31	62242 G.....	27	62283 J.....	21
62220 P.....	35	62243 A.....	23	62283 L.....	21
		62243 E.....	23	62284 A.....	17
62221 A.....	21	62244.....	27	62284 B.....	17
62221 C.....	21	62244 A.....	27	62284 C.....	21
62222.....	21	62245.....	21	62284 D.....	21
62224.....	33	62245 A.....	21	62284 E.....	21
62224 B.....	33	62245 B.....	21	62285.....	21
62224 C.....	33	62245 C.....	21	62285 A.....	21
62224 D.....	33	62246.....	21	62285 B.....	17
62224 E.....	33	62246 A.....	21	62285 C.....	21
62224 F.....	33	62251 A.....	21	62285 D.....	21
62228.....	33	62251 B.....	21	62285 E.....	21
62228 A.....	33	62251 C.....	21	62285 H.....	21
62228 B.....	33	62251 E.....	17	62285 J.....	17
62228 K.....	31	62252 A.....	21	62290 B.....	17
62228 L.....	31	62253 D.....	25	62291 A.....	21
62230.....	31, 35	62253 E.....	25	62292 C.....	25
62230 A.....	35	62253 F.....	25		
62230 D.....	31, 35	62253 H.....	25	62292 J.....	25
62230 E.....	35	62253 J.....	25	62292 K.....	25
62230 F.....	35	62253 K.....	25	62292 L.....	25
62230 G.....	35	62253 L.....	25	62292 M.....	17
62230 H.....	31, 35	62255 D.....	21	62292 N.....	25
62230 J.....	35	62255 E.....	21	62292 P.....	25
62230 K.....	35	62256.....	25	62292 R.....	25
62230 L.....	35	62257 A.....	25	62292 S.....	25
62230 M.....	35	62258.....	25	62292 T.....	25
62230 N.....	35	62259.....	25	62292 U.....	25
62230 R.....	35	62260.....	21	62292 V.....	25
62230 S.....	35	62260 G.....	23	62292 W.....	25
62230 T.....	31	62260 H.....	23	62294.....	17
62230 U.....	35	62261.....	23	62294 A.....	17
62230 V.....	35	62262.....	23	62294 C.....	19
62232 A.....	19	62268.....	25	62296 A.....	27
62232 B.....	19	62268 A.....	25	62296 B.....	27
62232 C.....	19	62268 E.....	25	62296 C.....	27
62232 D.....	19	62268 F.....	25	62296 D.....	27
62232 F.....	19	62268 G.....	25	63435 A.....	23
62232 G.....	23	62268 H.....	25	K67351.....	33
62234.....	23	62268 J.....	25	K67352.....	33
62236.....	23	62271 C.....	25	K67501.....	33
62236 A.....	23	62271 F.....	17	K68360.....	35
62236 C.....	19	62271 G.....	17	K68375.....	33
62236 D.....	23	62271 K.....	21	K68439.....	33
62236 F.....	23	62271 L.....	21	K68440.....	33
62238.....	23	62282.....	17	K68441.....	33
62238 A.....	23	62282 A.....	17	K68444.....	33
				K68445.....	33

NOTE: Only the basic part numbers are shown in the index. For various gauges, capacities, etc. available, refer to the listings on pages indicated.



Union Special[®]
INDUSTRIAL SEWING MACHINES

UNION SPECIAL maintains sales and service facilities throughout the world. These offices will aid you in the selection of the right sewing equipment for your particular operation. Union Special representatives and service men are factory trained and are able to serve your needs promptly and efficiently. Whatever your location, there is a Union Special Representative to serve you. Check with him today.

ATLANTA, GA.

BOSTON, MASS.

CHICAGO, ILL.

DALLAS, TEXAS

LOS ANGELES, CAL.

NEW YORK, N. Y.

PHILADELPHIA, PA.

MONTREAL, CANADA

TORONTO, CANADA

BRUSSELS, BELGIUM

LEICESTER, ENGLAND

LONDON, ENGLAND

PARIS, FRANCE

STUTTGART, GERMANY

Representatives and distributors in all important industrial cities throughout the world.

UNION SPECIAL CORPORATION
400 N. FRANKLIN ST., CHICAGO, ILL. 60610