

**FINEST QUALITY**

*Union Special*<sup>®</sup>

LEWIS • COLUMBIA

**INDUSTRIAL  
SEWING  
MACHINES**

**CLASS  
60000**

**CATALOG  
No.  
87A**

**INSTRUCTIONS  
FOR  
ADJUSTING  
STYLE 60000 D**

*Union Special* **MACHINE COMPANY**

**CHICAGO**

Catalog No. 87 A

ADJUSTING INSTRUCTIONS

CLASS 60000.

Style

60000 D

First Edition

Copyright 1945

by

Union Special Machine Co.  
Rights Reserved in All Countries

*Union Special*  
**MACHINE COMPANY**  
INDUSTRIAL SEWING MACHINES  
**CHICAGO**

Printed in U.S.A.

September, 1968

## ADJUSTING INSTRUCTIONS

FOR

STYLE 60000 D

### DESCRIPTION OF MACHINE

60000 D Flat bed, single needle, chain stitch Type 101, for closing small filled paper bags on Style 21800 N, with two paper reinforcing tapes, one guided next to presser foot and the other next to feed dog, seam Type SSa-1, round belt drive, trimming mechanism for top of bag, automatic cutter severing tape between bags, stitch range 5 to 8 per inch.

Needles for machine Style 60000 D are Type 924 and are available in sizes 049, 054, 067, 073 and 080. The size of the needle should be determined by the size of the thread. The thread should pass through the needle eye freely.

The following instructions apply to the machine as it sets in front of the mechanic on a repair table with the pulley to the right, and the needle bar in a vertical position.

## HOOK AND HOOK SHAFT

Insert a needle of the size required as far up in the needle bar as it will go with the scarf or spot toward the pulley end of the machine. Tighten the clamp nut. Wrench No. 116 is available for this purpose.

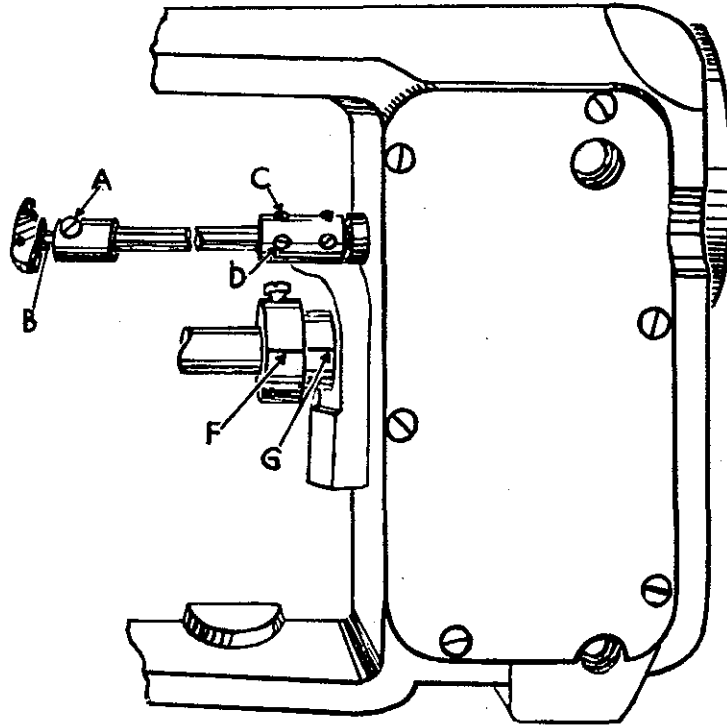

Fig. 1

The hook should be placed in the hook shaft so that the set screw (A, Fig. 1) in the shaft bears against the flat (B) on the shank of the hook and the set screw should be firmly tightened. With the needle bar in its lowest position, the hook should be set so that its point is  $\frac{3}{16}$  inch from the center of the needle (Fig. 2). Gauge No. 21225- $\frac{3}{16}$  can be used advantageously in making this adjustment. In order to obtain the above setting when the hook is out of adjustment, it becomes necessary to re-time the hook shaft.

In re-timing the hook shaft, the two screws (C, D, Fig. 1) in the hook shaft coupling should be loosened so the hook shaft turns freely. The shaft should then be turned with the fingers and the hook located properly, maintaining the needle bar in its lowest position. Retighten coupling screws securely.

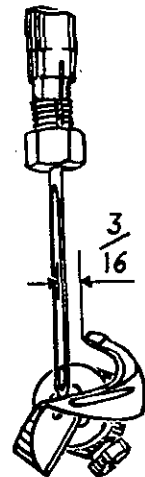

Fig. 2

The hook should also be set laterally so there is approximately .003 inch to .005 inch clearance between the spot in the needle and the point of the hook (Fig. 3). This is done by loosening set screw (A, Fig. 1) and moving the hook to the left or to the right as may be required and retightening the screw.

#### NEEDLE BAR HEIGHT

With the needle bar moving upwardly, the point of the hook should be even with the back of the needle (Fig. 4) when the bottom of the point is  $\frac{1}{64}$  inch above the eye of the needle. By loosening clamp screw (E, Fig. 14) the needle bar can be set to the correct height. As a final check see that the needle in its lowest position, does not strike the sides of the hole in the hook.

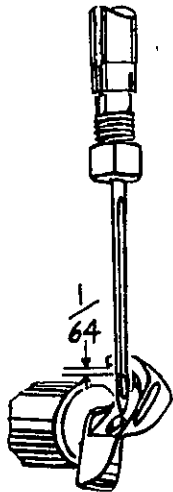

Fig. 4

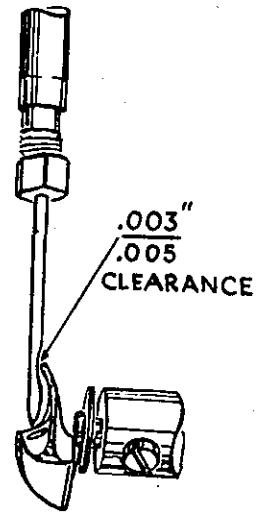

Fig. 3

#### FEED DOGS

The front feed dog (A, Fig. 5) should be set so that at its highest point of travel, it projects the full depth of the teeth above the throat plate. Height adjusting screw (C) for the front feed dog is set in the feed bar so that the screw driver slot is toward the bottom of the machine which makes for easier adjustment when machine is in operating position.

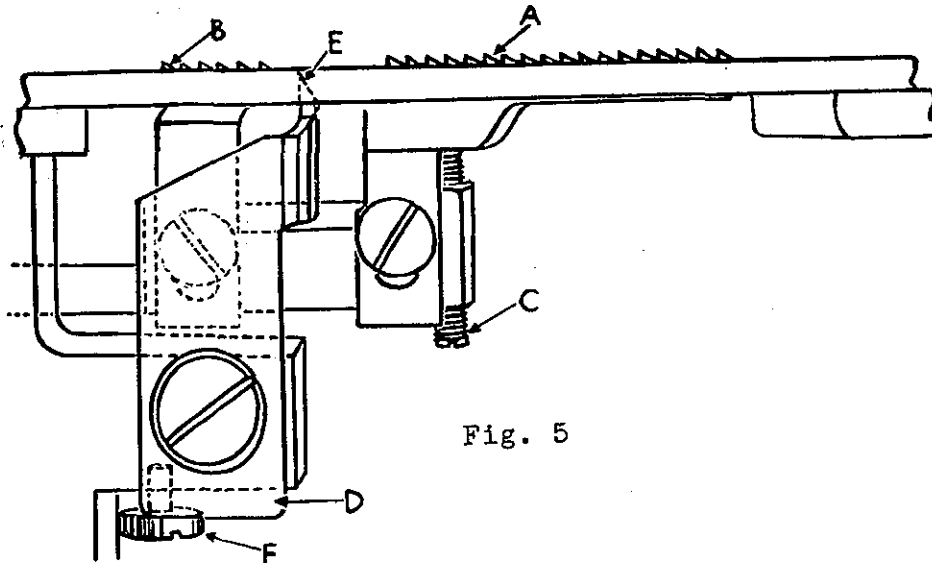

Fig. 5

The rear feed dog (B) should be set slightly lower than the front feed so that only  $3/4$  of the depth of a tooth extends above the throat plate when the feed dog is at its highest point of travel. This is done to prevent the possibility of the rear feed dog back feeding.

#### LOWER TAPE CUTTER KNIFE

Lower tape cutter knife (D, Fig. 5) should be set in the holder so that the knife edge (E) is located flush with the top of the throat plate. Adjusting screw (F) is used to raise the knife to its proper height and maintain this height when in operation.

#### UPPER TAPE CUTTER KNIFE

The upper tape cutter knife (B, Fig. 6) must be set after the tape cutter knife bar (A) has been correctly located. The knife should then be positioned so that the highest point of its cutting edge passes the cutting edge of the lower knife by  $1/32$  inch when the knife bar is in its lowest position.

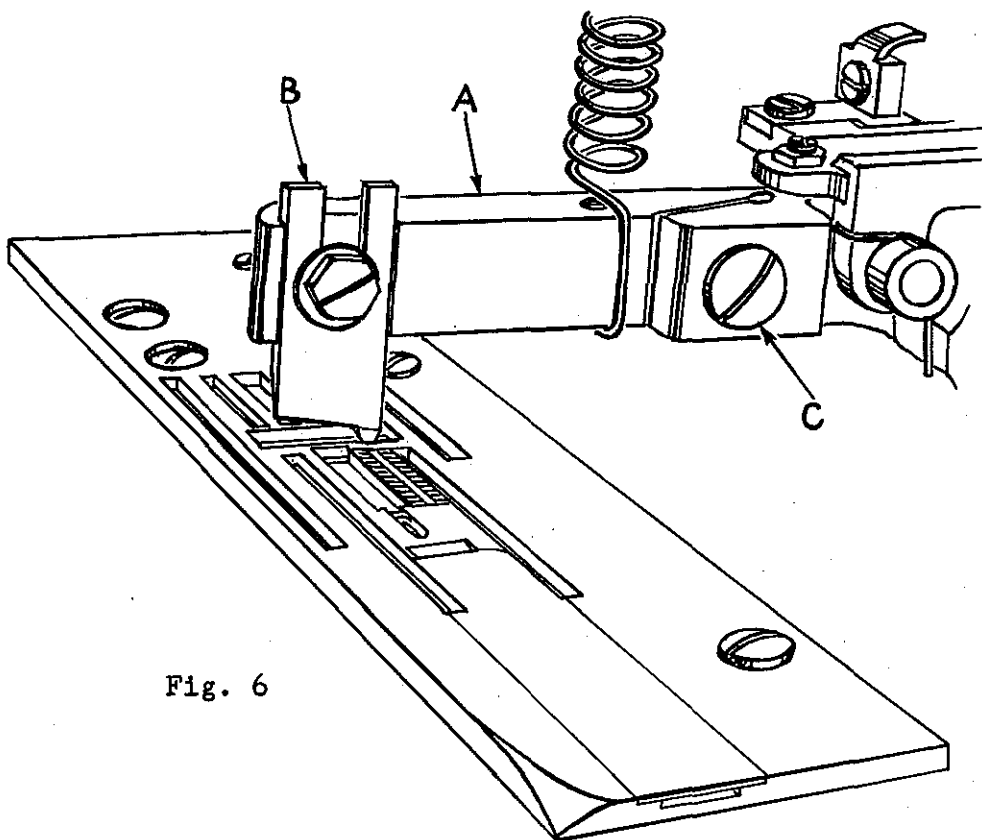

Fig. 6

For efficient operation, the cutting edges of the upper and lower knives must have a slight shearing angle so that there will be a cutting action the whole length of the blades. This angle is set in the upper knife mechanism at the factory.

The two cutting edges must exert a pressure against one another. The amount of pressure should be such that it can be felt in the upper tape cutter knife bar when the knife bar is pressed down with the finger. The pressure is obtained by adjusting the screw (C, Fig. 6) in the upper tape cutter knife bar. Turning screw to the right adds pressure against lower knife, turning screw to the left acts the reverse.

#### AUTOMATIC TAPE CUTTING MECHANISM

The automatic tape cutting mechanism has four main adjustments. Adjustment No. 1 (Fig. 7) regulates the stop position of actuating lever (A). This stop is properly set when there is a small amount of play, from  $1/32$  to  $1/16$  inch, between points (B) and (C) when the mechanism is at rest.

Adjustment No. 2 is for the spring that maintains a downward tension on the actuating shoe (D). The tension on this spring is corrected by loosening the two set screws (F) and turning stud (G) clockwise to increase tension and counterclockwise to reduce tension. The tension on this spring should be only sufficient to operate the mechanism promptly as shoe (D) rides off the bag. Too great a tension

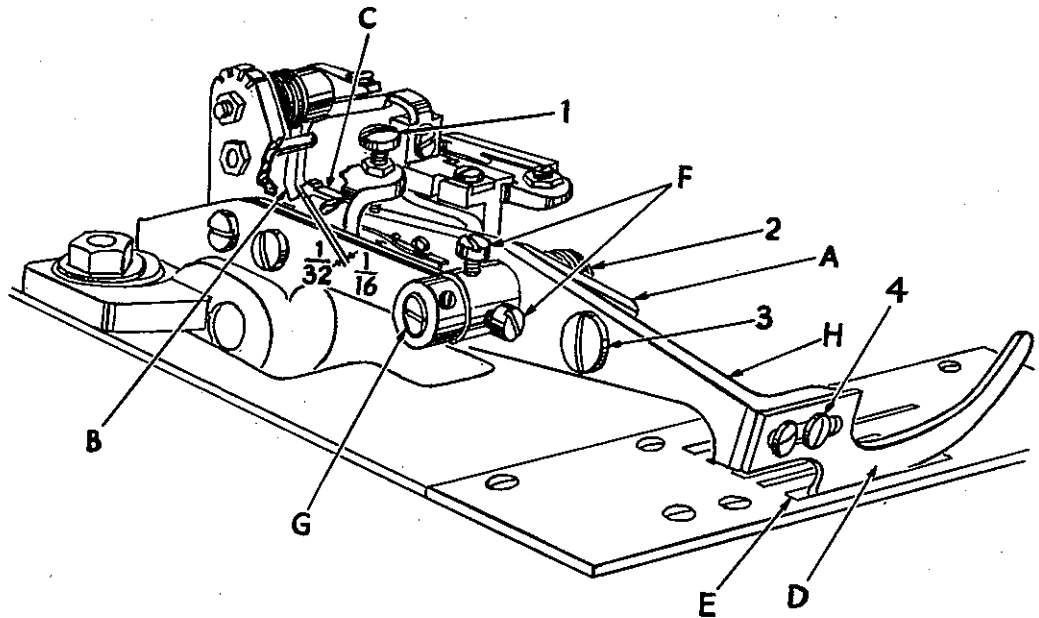

Fig. 7

on this spring will cause the shoe to force the bag down into the throat plate slot (E) causing the front end of the bag to have uneven tape ends. Tighten screws (F) securely when the tension has been properly adjusted.

Adjustment No. 3 limits the distance shoe (D) drops into the throat plate slot (E) and controls the position of cutting as shoe (D) rides on to the bag. This depth of adjustment is proper when shoe (D), in its upward travel, is about  $1/32$  inch below the top surface of throat plate as the points (B) and (C) pass.

Adjustment No. 4 locates the position of shoe (D) on the end of the actuating lever extension (H) and controls the length of tape on the ends of the bag. The overall length of the tape is a fixed amount and is only divided on each end of the bag by the location of shoe (D). This automatic tape cutting mechanism, although it appears complicated and to have numerous adjustments, is relatively simple in that all adjustments are fixed and there is no reason to deviate from instructions. Properly adjusted, it will give a positive single clip at each end of the sewn bag and will not double chop.

Several details of the tape cutting mechanism were not discussed in the instructions for the four main adjustments because they do not actually enter into the adjusting of the unit. It is, however, necessary that the mechanic have some knowledge of these because they are important to the functioning of the unit in the event it should be necessary to replace any parts.

The actuating lever dog (A, Fig. 8) is held on to the actuating lever (B) by a hinge screw (C). The amount of hinge of (A) on (B) is limited by two stop pins (D). The position of the dog (A) is controlled by the stationary spring (E) and stationary pin (F). The function of this

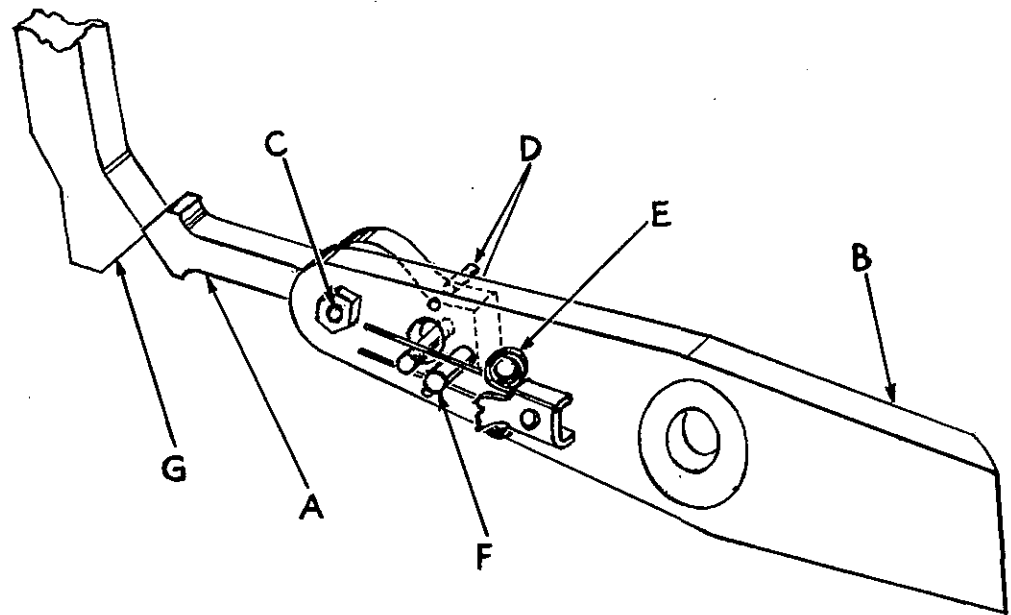

Fig. 8

spring is to allow the point of (A) to lag as it contacts the point of the trip dog (G) until the actuating dog (A) reaches the limit of hinge controlled by pins (D). Spring (E) then accelerates the point of (A) in the direction the lever is moving to make the points of (A) and trip dog (G) pass each other by a considerable amount and prevent the possibility of a double chop.

After the upper tape cutter knife (B, Fig. 6) has been temporarily assembled in the upper tape cutter bar (A), set the bar height by manipulating adjusting screw (C, Fig. 9) so that .015 to .020 inch distance remains between the point of driving pawl (A, Fig. 9) and the point of ratchet lever (B)



when the ratchet lever is in its lowest operating position. Maintain this adjustment by locking the nut (D) on adjusting screw (C).

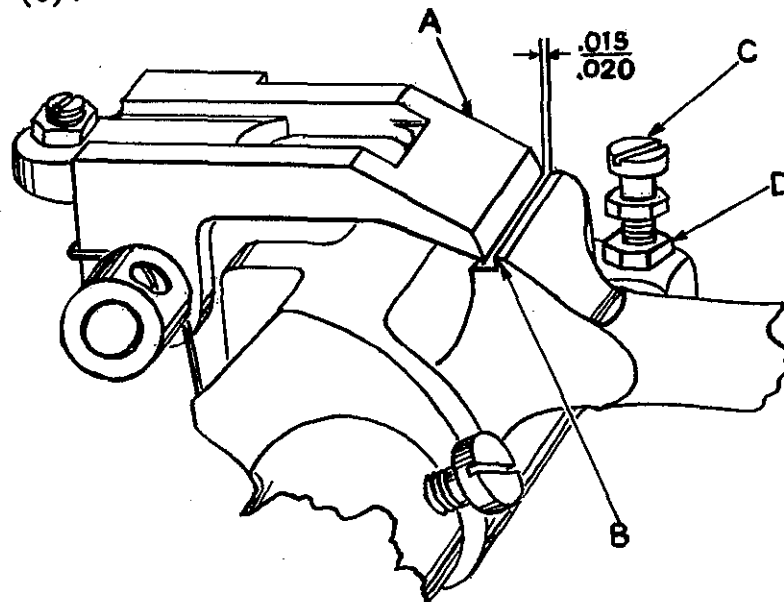

Fig. 9

TO ADJUST HEIGHT OF THE DRIVING PAWL ABOVE RATCHET LEVER

With set screw (A, Fig. 10) released from position, adjust the point of pawl (B) above the point of ratchet

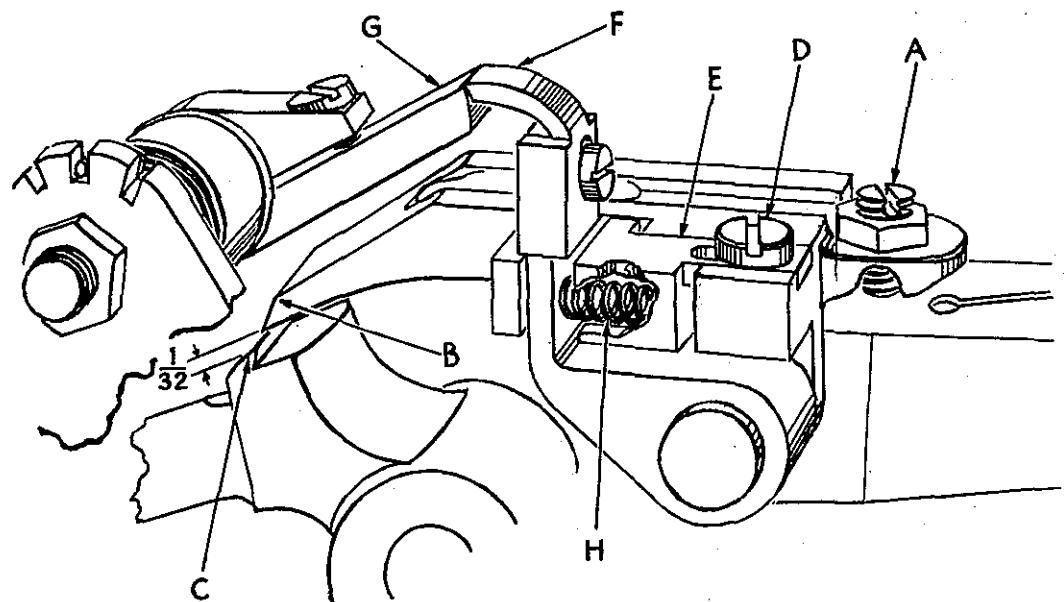

Fig. 10

lever (C) to 1/32 inch by loosening screw (D) and moving adjusting block (E) in or out whichever is required. This

adjustment is made when the pawl lever extension (F) is resting against dog (G). Retighten screw (D) securely. Maintain this position by setting and locking screw (A) to this height, but do not exert a tension on spring (H) with screw (A).

The trip of this mechanism is accurately set when the point of the pawl lever extension (A, Fig. 11) passes over the top of the point of dog (B) momentarily before the point

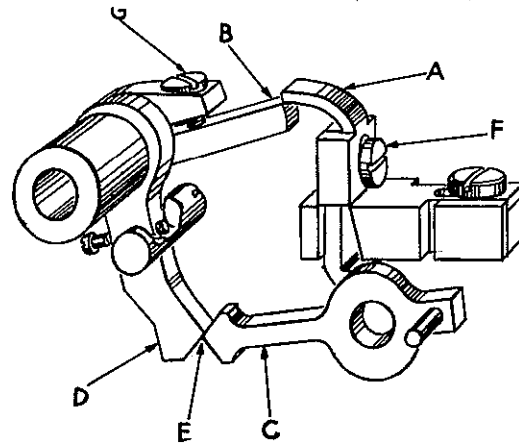

Fig. 11

of the actuating lever trip dog (C) passes the point of dog (D) at position (E) when the actuating lever is moved either up or down causing the points at (E) to pass. This adjustment is made by loosening clamp screw (G) and moving the dog (B) up or down whichever is required. NOTE: On machines having the dogs (B and D) in one integral unit without any clamp screw (G), this adjustment is made by loosening the screw (F) and moving the pawl lever extension (A) up or down as required.

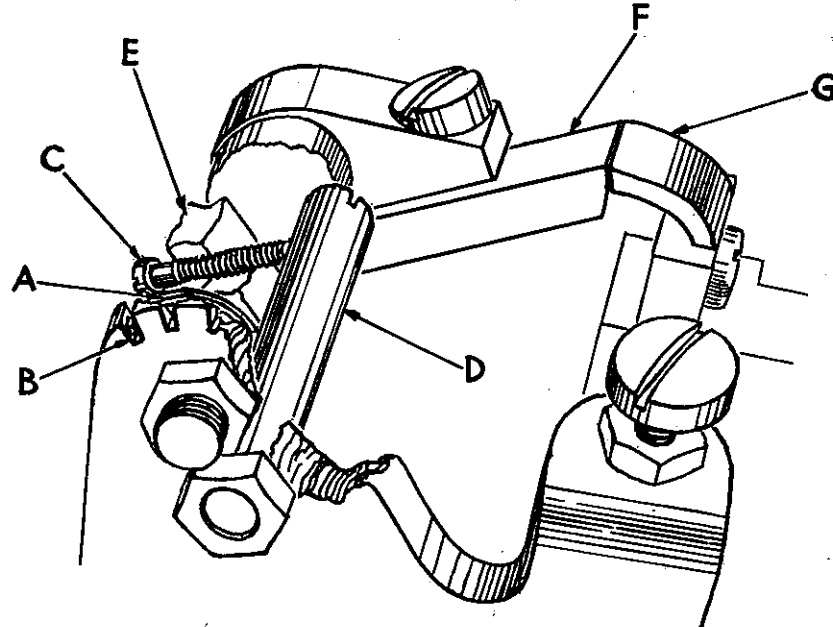

Fig. 12

The height of dog (F, Fig. 12) is properly set by adjusting screw (C) against stop pin (D) until the point of the dog (F) is flush with the top of the lever extension (G). This adjustment and the one in the preceding paragraph may seem to conflict. However, by working these two adjustments together the desired settings will be obtained.

Spring (A, Fig. 12) should be positioned in the proper notch of bracket (B) to return screw (C) against stop pin (D) during the clipping cycle when the dog (E) is free to move.

Another feature not mentioned in the adjusting instructions is the action of springs (A and B, Fig. 13). Spring (A) engages the driving pawl (C) into ratchet lever (D) when dog (E) is tripped by the movement of the actuating lever. It is important that this spring be strong enough to overcome the tension of spring (F) that holds dog (E) in position.

EXAMPLE: If dog (E) is tripped while the ratchet lever (D) is in its forward position as indicated by dotted line, pawl (C) will by action of spring (A) drop to rest on top of ratchet lever (D). Pawl (C) will not drop into operating position until (D) has returned to the back of its stroke. It is then necessary for spring (A) to drop pawl (C) into ratchet lever (D) firmly and completely. In making this

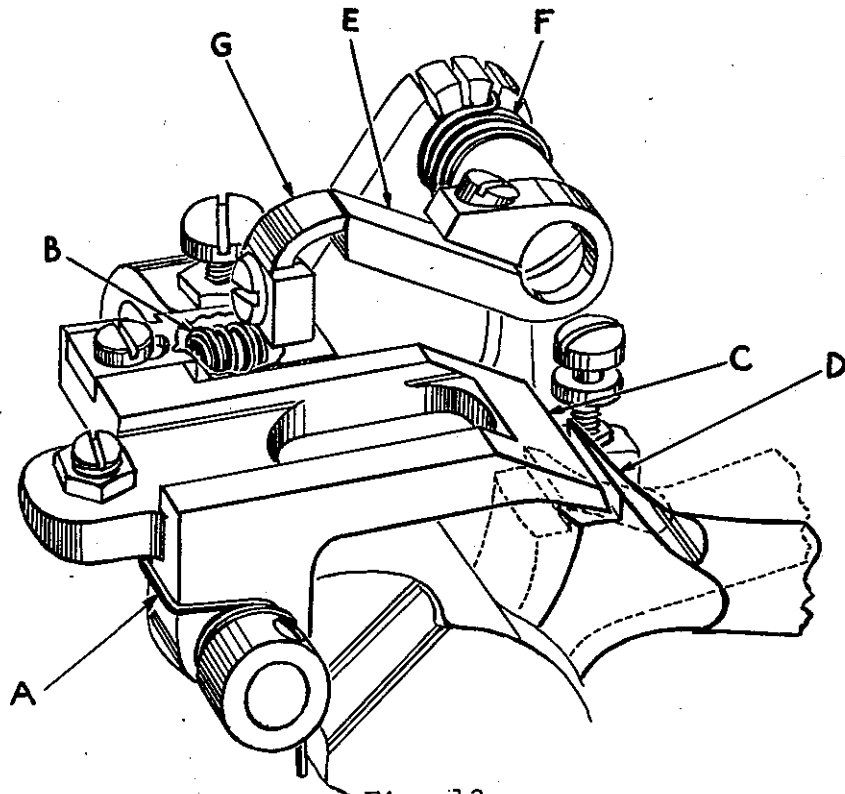

Fig. 13

motion, the pawl lever extension (G) forces dog (E) downward thereby overcoming the action of spring (F) which holds dog (E) up into position.

Spring (B) is a strong spring and used only to cushion the disengagement of pawl (C) from ratchet lever (D) when the clipping cycle is completed.

EXAMPLE: As ratchet lever (D, Fig. 13) is returning to its lowest position and the knife bar is coming up from the clip, pawl lever extension (G) contacts dog (E), which has returned to rest position by action of spring (F). Spring (B) is then compressed until the knife bar comes to rest against its stop screw. Pawl (C) is then disengaged by the action of spring (B) overcoming the tension of spring (A).

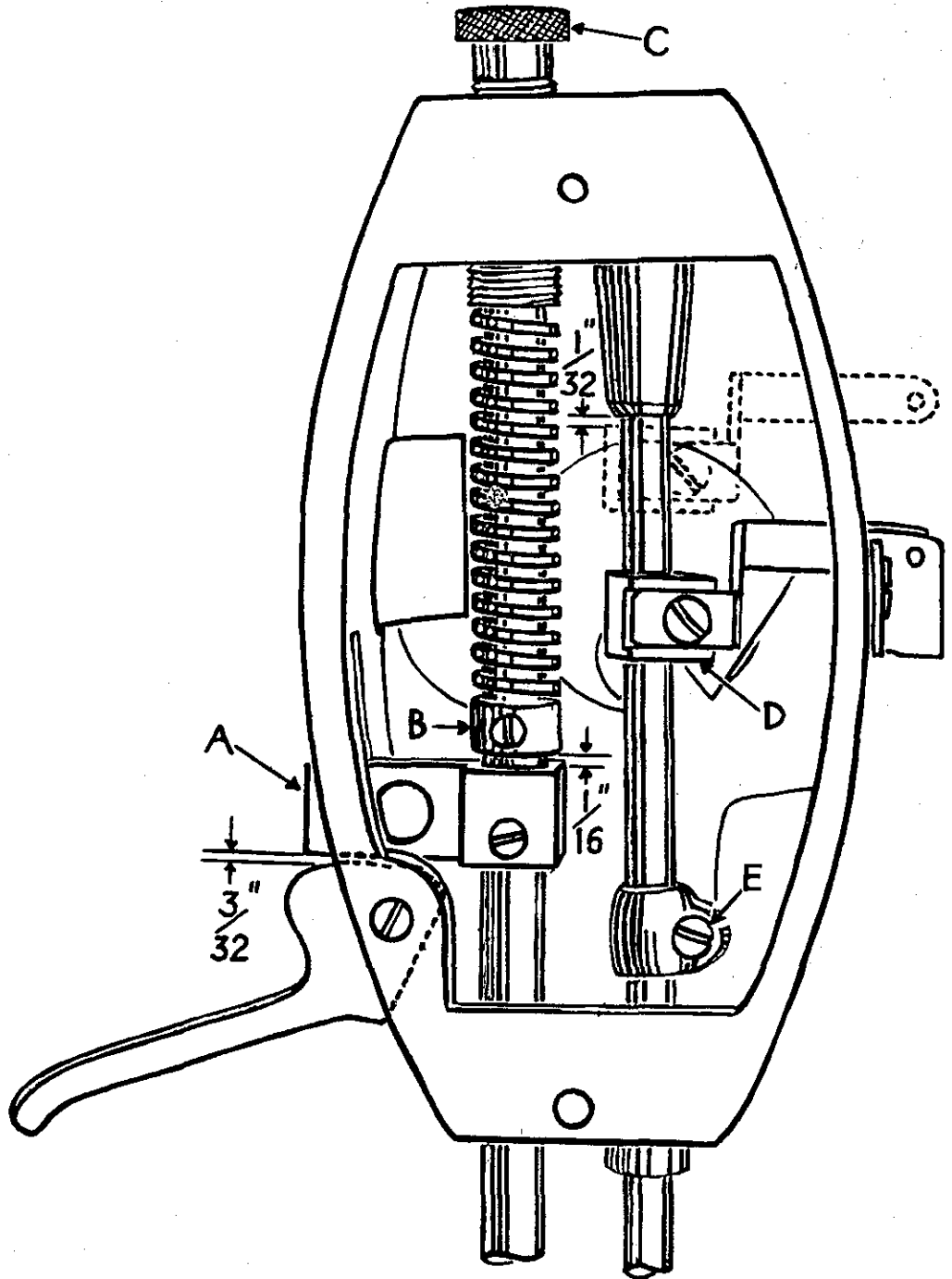

Fig. 14

### PRESSER BAR HAND LIFTER

Assemble the presser foot to the presser bar. Turn handwheel so the feed dog is in its lowest position. Set presser bar connection (A, Fig. 14) so there is  $3/32$  inch clearance between it and the hand lifter.

### PRESSER BAR

Set the lower presser spring collar (B, Fig. 14) so there is  $1/16$  inch clearance between the top of the presser bar connection and the bottom of the collar.

Only enough pressure to feed the material uniformly should be applied to the presser foot. To increase the pressure turn the regulator (C) in a clockwise direction. Turning the regulator in the opposite direction releases the pressure.

The presser bar can be swung in any position desired to line up the front presser foot by loosening the set screw in the presser bar connection (A, Fig. 14).

### NEEDLE BAR EYELET

With the needle bar in its highest position, the needle bar thread eyelet holder (D, Fig. 14) should have  $1/32$  inch clearance between it and the bottom of the bushing. To set the eyelet correctly, turn handwheel until needle bar is in its highest position, loosen eyelet holder clamp screw and move eyelet and eyelet holder to their correct positions.

### TAKE-UP EYELET

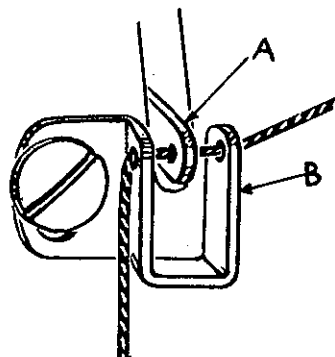

Fig. 15

When the needle bar thread eyelet (A, Fig. 15) is at the bottom of its stroke, the take-up eyelet (B) should be positioned so that a thread drawn through the take-up thread holes and the needle bar thread eyelet hole will form a horizontal line. Also, the needle bar thread eyelet, in its lowest position, should be located in the middle of the needle thread take-up eyelet equidistant from the two take-up eyelet thread holes.

### BAG TRIMMING KNIFE

The bag trimming knife (A, Fig. 16) should be set centrally in the knife slots in the presser foot and throat plate. It should also be set so that when at its highest position, the point of the knife is  $1/32$  inch below the surface of the throat plate. In order to set the knife for height loosen knife driving stud clamp screw "B" which allows the knife and knife holder to be moved up or down to proper position. To set the knife laterally, loosen screws (C) and locate knife in center of knife slot.

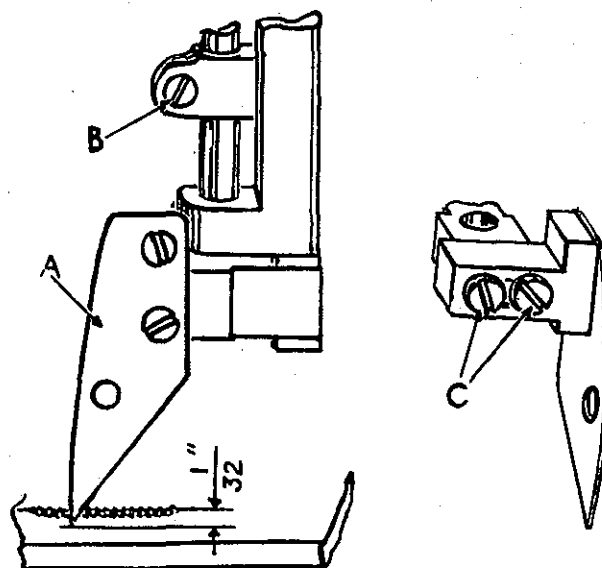

Fig. 16

INTERMITTENT THREAD NIPPER

The thread nipper is set correctly when a maximum amount of tension can be applied to the spring without breaking the thread and yet have sufficient opening between the tension discs to allow free passage of thread as the tension is released. After the nipper mechanism has been adjusted, the tension should be relieved and just enough tension applied to eliminate occasional large loops in the stitching, and to prevent the hook from catching the cast off loops causing broken stitches to occur in the sewing.

The nipper mechanism is adjusted by raising or lowering the thread nipper sleeve (A, Fig. 17) in the sleeve holder (B). The opening between the discs, can be increased by loosening the set screw (C) and tapping the top of the tension post forcing the nipper mechanism deeper into the sleeve holder. Inserting a screw driver between the tension eyelet and the sleeve holder and forcing the nipper mechanism up decreases the amount of opening between the discs.

The nipper mechanism is set correctly for a 12-4 twine when there is a 3/64 inch space between the discs at their open position. The sleeve should then extend 3/64 inch out of the sleeve holder.

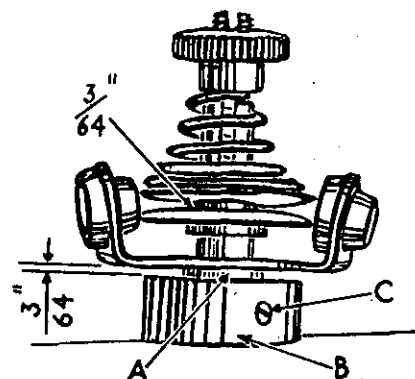
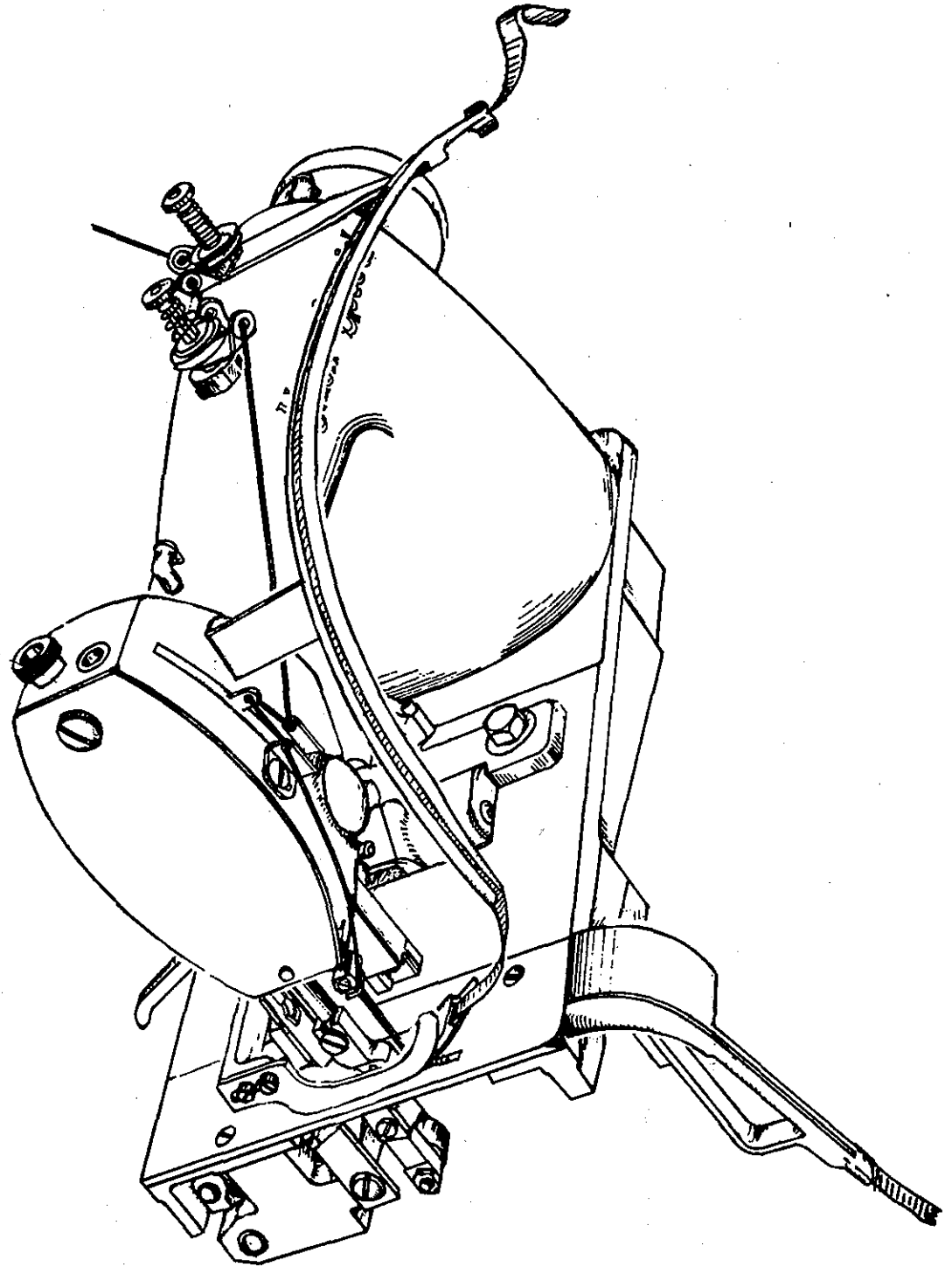

Fig. 17

## THREADING

Thread the machine as shown in the threading diagram (Fig. 18) noting the position of the tension eyelets.

The needle thread tension (the one nearest the cone of thread) should be set so that just enough tension is applied to the thread to pull up a neat stitch.



## TAPE GUIDES

The lower tape guide must be set so that the delivery end fits up against tape opening in the throat plate. The tape should then slide from the guide into the throat plate in one continuous motion until it contacts the presser foot.

The setting of the upper tape guide is a matter of placing its brackets in their proper places. Refer to the threading diagram (Fig. 18) for these adjustments.

## STITCH LENGTH

To set the length of stitch, loosen the hexagonal head screw (A, Fig. 19) that holds the feed drive eccentric connecting rod to the feed rocker. Wrench No. 21388 AG is available for this purpose. Moving the sleeve screw nut (B) in the feed rocker slot (C) toward the cloth plate shortens the stitch, the reverse lengthens the stitch. Make sure that hexagonal head screw is tight after setting the stitch length.

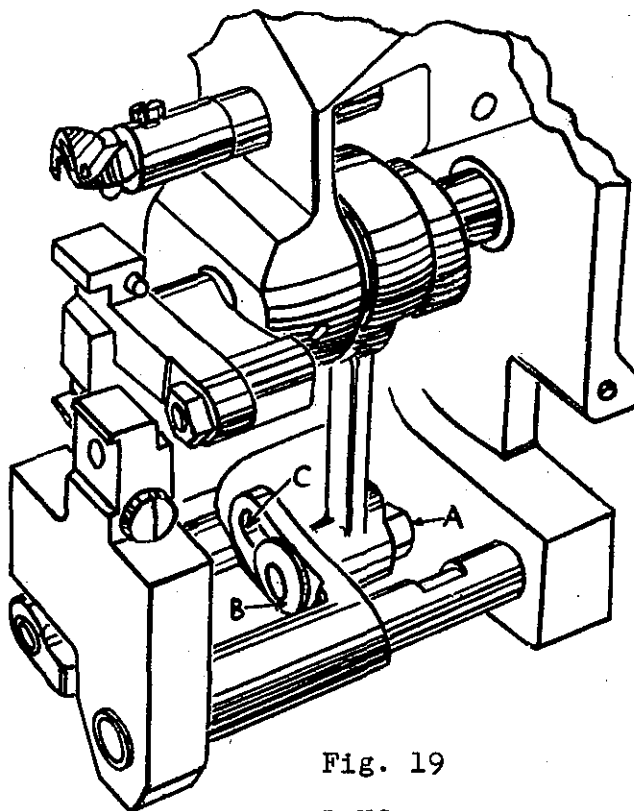

Fig. 19

## OILING

Before starting the machine, make sure that all oiling points as indicated on (Fig. 20) are lubricated with a straight mineral oil similar to an S.A.E. 10 W. The oiling points are arranged in numerical sequence on the chart for the operator's convenience.

When machine is operated all day long and in hard service, oil twice daily, once at the morning start and again at the noon start. If there is a large quantity of dust in the air, more frequent oiling will be beneficial.



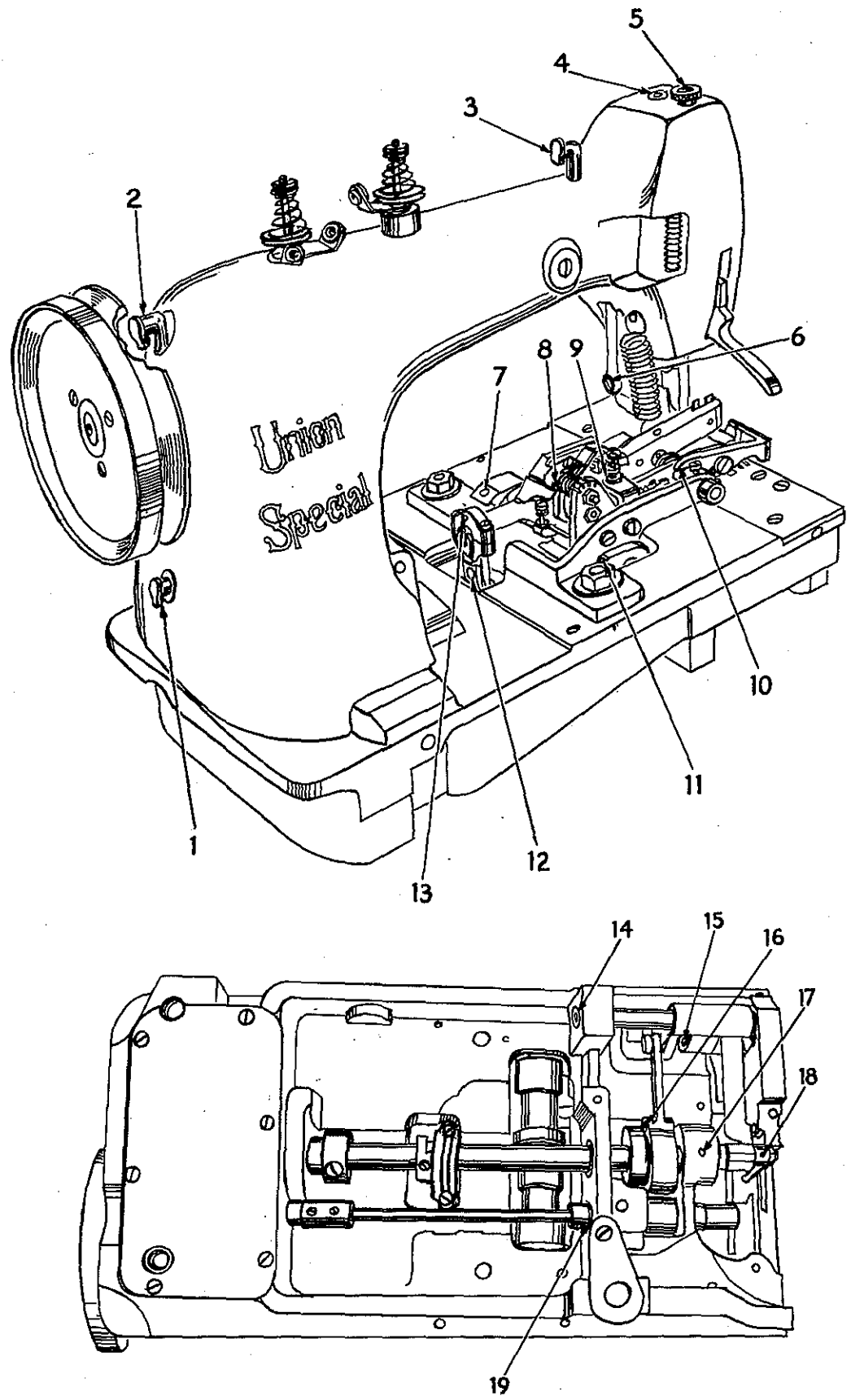

Fig. 20

The amount of grease in the gear housing should be checked semi-annually to keep gears well lubricated. If more is necessary, refill with grease similar to a commercial No. 3.

The correct application of good quality oil and grease will add years of service and trouble free operation.

#### FEED TIMING

The feed dog and needle bar motions are synchronized so that when the handwheel is turned in the operating direction and the needle bar is moved downwardly until the top of the eye of the needle is even with the top surface of the throat plate, the teeth of the feed dog are .015 inch above the throat plate and the feed is descending.

This adjustment is made at the factory. For convenience in checking, timing marks will be found on the feed drive shaft collar and its adjoining bushing (F, G, Fig. 1). If the machine is synchronized as described above, the timing marks will coincide when the needle bar is at the bottom of its stroke.

#### CAUTION:

Do not change timing of machine unless it becomes absolutely necessary. If machine does not operate correctly, check all the other adjustments on the machine. In all probability, it will be found that some other adjustment has not been taken care of.

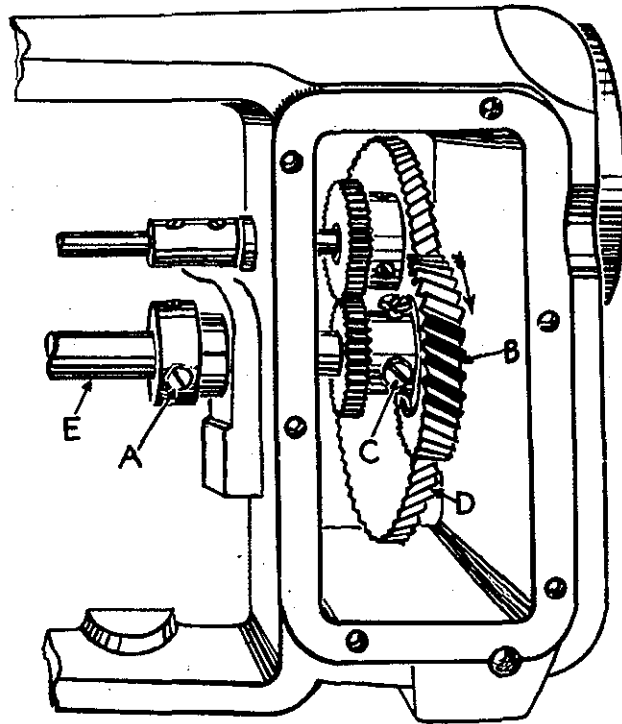

Fig. 21

Should it become necessary to change the timing the following procedure must be observed.

1. Check to see if the fillister head screw in the feed driving shaft collar (A, Fig. 21) bears against the flat on shaft (E).
2. Remove gear housing cover.
3. Check position of feed driving gear (B) on the shaft. When the handwheel is turned in the operating direction and the feed driving gear is rotating in the direction indicated by the arrow (Fig. 21), the first screw coming into view is the time screw (C) and should bear against the flat on the shaft. The flat for the time screw is in line with the flat for the feed driving shaft collar set screw.
4. Loosen the screws in the feed driving gear and disengage the gear from the intermediate gear (D) by sliding it to the right.
5. Turn handwheel in operating direction until needle bar is at the bottom of its stroke.
6. Turn the feed driving shaft (E) with the fingers until the timing marks on the collar and the bushing coincide.
7. Re-engage driving gear temporarily with the time screw up as high as possible and still remain accessible to a screw driver (Fig. 22). Tighten screw only enough to maintain adjustments.

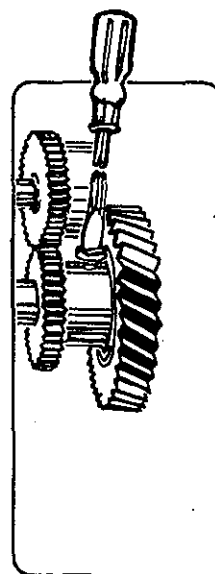

Fig. 22

8. Turn handwheel in operating direction until fillister head screw (A, Fig. 21) in the feed driving shaft collar is in line with the timing mark on the bushing.
9. Loosen time screw in driving gear, disengage gear, holding handwheel to maintain settings, and turn driving gear so that the time screw is in line with the timing mark on the bushing. Re-engage gear and tighten all screws securely.
10. Check timing and reset hook and hook shaft as previously described.



*Union Special*<sup>®</sup>  
INDUSTRIAL SEWING MACHINES

UNION SPECIAL maintains sales and service facilities throughout the world. These offices will aid you in the selection of the right sewing equipment for your particular operation. Union Special representatives and service men are factory trained and are able to serve your needs promptly and efficiently. Whatever your location, there is a Union Special Representative to serve you. Check with him today.

**ATLANTA, GA.**

**BOSTON, MASS.**

**CHICAGO, ILL.**

**DALLAS, TEXAS**

**LOS ANGELES, CAL.**

**NEW YORK, N. Y.**

**PHILADELPHIA, PA.**

**MONTREAL, CANADA**

**TORONTO, CANADA**

**BRUSSELS, BELGIUM**

**LEICESTER, ENGLAND**

**LONDON, ENGLAND**

**PARIS, FRANCE**

**STUTTGART, GERMANY**

Representatives and distributors in all important industrial cities throughout the world.

*Union Special*

**MACHINE COMPANY**

**400 N. FRANKLIN ST., CHICAGO, ILL. 60610**