

**SECOND
EDITION**

Union Special[®]
INDUSTRIAL SEWING EQUIPMENT

CATALOG NO. 97N

STYLES

52900BF

52900BG

52900BH

52900BL

52900BM

52900BN

52900BP

52900BR

STREAMLINED

HIGH SPEED

SAFETY STITCH MACHINES

FRONT DIPOSAL OF TRIMMINGS

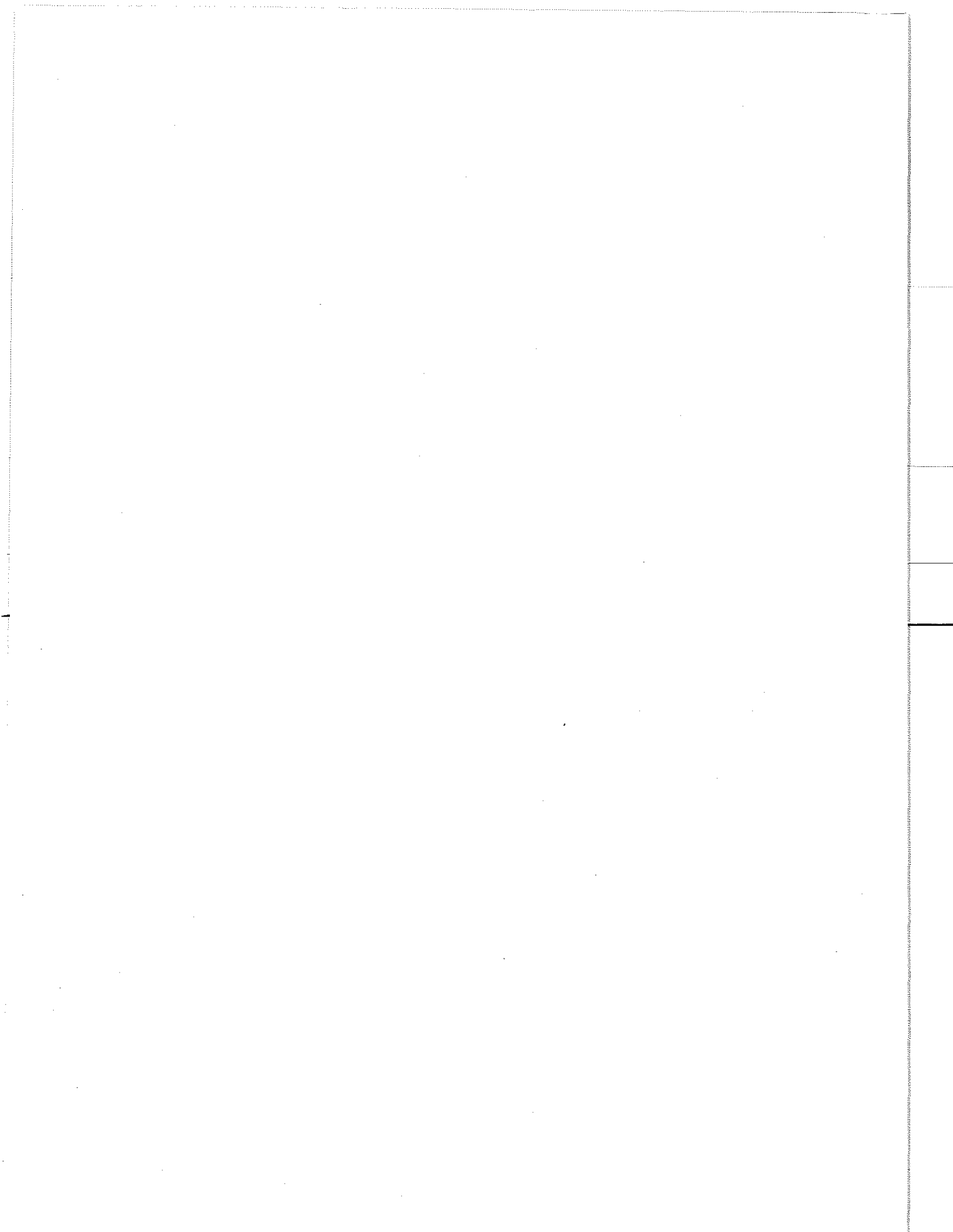

Catalog No. 97 N

LIST OF PARTS

For Styles

52900 BF	52900 BL
52900 BG	52900 BM
52900 BH	52900 BN
52900 BP	
52900 BR	

Second Edition

Copyright © 1960

by

Union Special Corporation
Rights Reserved in All Countries

UNION SPECIAL CORPORATION

INDUSTRIAL SEWING MACHINES

CHICAGO

Printed in U. S. A.

September, 1978

FOREWORD

These latest improved famous UNION SPECIAL "Safety Stitch", Class 52900 machines offer many advantages on seaming-overedging operations on various types of garments such as pants, slacks, ladies' skirts, jackets, bathing suits, beach and bathrobes, kiddies' corduroy overalls, sport shirts, ladies' blouses, street and house dresses, nightgowns, dungarees, ladies' jeans, pedal pushers and similar garments.

New light weight parts and needle bearings make them lighter running and smoother operating. A new light weight presser bar mechanism reduces pressure required to lift the foot.

Increased speed has been made possible by design changes and the new filter type oil return pump, used in conjunction with isolated mounting oil pan base plate, which returns any excess oil to reservoir.

It is our constant aim to furnish carefully prepared information which will enable our customers to secure all possible advantages from the use of UNION SPECIALS. The following pages illustrate and describe the parts for Styles in Class 52900 - front disposal of trimmings.

Union Special representatives will be found in all manufacturing centers, ready to cooperate with you to plan and estimate requirements.

UNION SPECIAL CORPORATION
Engineering Department

IDENTIFICATION OF MACHINE

Each UNION SPECIAL carries a Style number which is stamped in the name plate on the machine. Style numbers are classified as standard and special. Standard Style numbers have one or more letters suffixed, but never contain the letter "Z". Example: "Style 52900 BF". Special Style numbers contain the letter "Z". When only minor changes are made in a standard machine, a "Z" is suffixed to the standard Style number. Example: "Style 52900 BFZ".

The distance between the rows of stitches or between needles is represented by a gauge number measured in 1/64ths of an inch, going from left to right. Thus, 5-8 gauge represents a distance of 5/64 inch from left needle (needle for 401 stitch) to middle or left needle of 602 stitch and 8/64 or 1/8 inch from middle needle to extreme right needle. Similarly, 1-11-12 gauge on tandem needle Style 52900 BP represents a distance of 1/64 of an inch from left row of 401 stitch to right row of 401 stitch, 11/64 of an inch from right row of 401 stitch to left needle of 602 stitch and finally 12/64 or 3/16 of an inch from left needle of 602 stitch to extreme right needle.

APPLICATION OF CATALOG

This catalog applies specifically to the standard Styles of machines as listed herein. It can also be applied with discretion to some Special machines in this Class. Reference to direction such as right, left, front, back, etc., are given from the operator's position while seated at the machine. Operating direction of handwheel is toward the operator.

STYLES OF MACHINES

High Speed Streamlined Flat Bed, Medium and High Throw Machines, Vertical Trimmer, Front Disposal of Trimmings, Light Weight Presser Bar and Needle Bar Driving Mechanism. Three Needles, Left Needle in Rear, Two Loopers, Dual Stitch, Double Locked Stitch on Left, Four Thread Interlock Stitch on Right Unless Otherwise Specified. One Reservoir Enclosed Automatic Lubricating System with Filter Type Oil Return Pump for Main Driving Mechanism, Separate Reservoir for Automatic Lubrication of Spreader Mechanism, Lateral Looper Travel.

52900 BF Medium throw machine for simultaneous seaming and overedging on garment pockets and for similar operations on medium to medium heavy weight material. Seam specification 401 and 602-SSa-2. Type 128 GAS needle. Standard gauge No. 5-8 only. Maximum recommended speed 5000 R. P. M.

52900 BG Medium throw machine for simultaneous seaming and overedging on sport shirts, ladies' blouses, street and house dresses, shoulder pads, coat linings, pillow cases and for similar operations on medium to medium heavy weight material. Seam specification 401 and 602-SSa-2. Type 128 GAS needle. Standard gauges Nos. 5-8, 16-8, 24-8. Maximum recommended speed 5000 R. P. M.

52900 BH Medium throw machine for simultaneous seaming and overedging on the in-seams and out-seams of light and medium weight corduroy pants, wash pants, slacks, ladies' skirts, jackets, bathing suits, beach and bathrobes, kiddies' corduroy overalls, and for similar operations on light to medium weight material. Seam specification 401 and 602-SSa-2. Type 128 GAS needle. Standard gauges Nos. 5-8, 12-12, 16-8. Maximum recommended speed 5000 R. P. M.

STYLES OF MACHINES (Continued)

52900 BL Medium throw machine with treadle controlled intermittent differential feed mechanism for setting puff sleeves, shirt backs to yokes, and a variety of operations on street and house dresses, nightgowns, nylon blouses, bathing suits and for similar operations on light to medium weight material. Seam specification 401 and 602-SSa-2. Type 128 GAS needle. Standard gauges Nos. 5-8, 12-12, 16-8. Maximum recommended speed 5000 R. P. M.

52900 BM Medium throw machine with top feed mechanism for seaming and inserting a corded welt to furniture slip covers and for similar operations on medium to heavy weight material. Seam specification 401 and 602-SSk-2. Type 128 GAS needle. Standard gauges Nos. 5-8, 12-12. Maximum recommended speed 4000 R. P. M.

52900 BN High throw machine for side seaming, shoulder seaming, sleeve setting and closing on sport shirts, play pants, heavy bathrobes, and for similar operations on medium heavy to heavy weight material. Seam specification 401 and 602-SSa-2. Type 147 GS needle. Standard gauges Nos. 5-8, 12-12, 16-8. Maximum recommended speed 5000 R. P. M.

52900 BP High throw, four needle, three looper, tandem needle machine for producing two rows of 401 stitching 1/64 inch apart and with a Type 602 overedge stitch. Tandem needles mounted to left and rear of two needles abreast, producing Type 602 stitch. The tandem needle arrangement gives an equivalent of 14 stitches per inch on the 401 stitch as compared to 6 stitches per inch on the 602 overedge stitch. Designed to handle materials made of seersucker, denim, corduroy, twill, drill, etc. For inseaming, side seaming, front seaming, seat seaming on men's work, service and semi-dress pants, dungarees, ladies' jeans, pedal pushers, and for similar operations on medium to heavy weight material. Seam specification 401 and 602-SSa-3. Type 128 GAS needle. Standard gauge No. 1-11-12 only. Maximum recommended speed 4500 R. P. M.

52900 BR Same as Style 52900 BH except feed dog has teeth cut 22 per inch and throat plate has .050 inch needle holes, for sewing garments made of durable press material. Seam specification 401 and 602-SSa-2. Type 128 GAS needle. Standard gauges Nos. 5-8 and 12-12. Maximum recommended speed 5000 R. P. M.

NEEDLES

Each needle has a type number and size number. The type number denotes the kind of shank, point, length, groove, finish and other details. The size number denotes the largest diameter of the blade, measured in thousandths of an inch, midway between the shank and the eye, and is stamped in the needle shank. Collectively, the type number and size number is the complete symbol.

To have needle orders promptly and accurately filled, forward a sample needle, the empty package, or description on label. A complete order would read as follows: "1000 Needles, Type 128 GAS, Size 100/040".

The type numbers of the needles recommended for each style of machine covered by this catalog are given in the machine style description. Other needles are available, but the ones indicated are those recommended to produce the most satisfactory results. The type numbers of the recommended needles together with their descriptions, and the sizes available are listed on next page.

NEEDLES (Continued)

<u>Type No.</u>	<u>Description and Sizes</u>
128 GAS	Short, double groove, struck groove, ball eye, spotted chromium plated - sizes 080/032, 090/036, 100/040, 110/044, 125/049, 140/054, 150/060, 170/067.
147 GS	Long, double groove, struck groove, ball eye, spotted short point, undersize eye and grooves, one step reduction, chromium plated - sizes 080/032, 090/036, 100/040, 110/044, 125/049, 140/054, 150/060, 170/067.

Selection of the proper needle size should be determined by size of thread used. Thread should pass freely through needle eye in order to produce a good stitch formation.

ORDERING REPAIR PARTS

ILLUSTRATIONS

This catalog has been arranged to simplify ordering repair parts. Exploded views of various sections of the mechanism are shown so that the parts may be seen in their actual position in the machine. On the page opposite the illustration will be found a listing of the parts with their parts numbers, descriptions and the number of pieces required in the particular view being shown.

Numbers in the first column are reference numbers only, and merely indicate the position of that part in the illustration. Reference numbers should never be used in ordering parts. Always use the part number listed in the second column.

Component parts of sub-assemblies which can be furnished for repairs are indicated by indenting their descriptions under the description of the main sub-assembly. Example:

61	29476 LE	Looper Driving Lever Crank Assembly -----	1
62	22587	Screw, upper -----	2
63	22729 D	Screw -----	1
64	51243 C	Ball Stud Guide -----	1
65	22729 D	Screw, lower -----	2

It will be noted in the above example that the eccentric and bearing are not listed. The reason is that replacement of these parts individually is not recommended, so the complete sub-assembly should be ordered.

In those cases where a part is common to all of the machines covered by this catalog, no specific usage will be mentioned in the description. However, when the parts for the various machines are not the same, (the specific machine style or styles covered on that page will be noted on top of page or) the specific usage will be mentioned in the description and, if necessary, the difference will be shown in the illustration.

At the back of the book will be found a numerical index of all the parts shown in this book. This will facilitate locating the illustration and description when only the part number is known.

IDENTIFYING PARTS

Where the construction permits, each part is stamped with its part number. On some of the smaller parts, and on those where construction does not permit, an identification letter is stamped in to distinguish the part from similar ones.

IDENTIFYING PARTS (Continued)

Part numbers represent the same part, regardless of catalog in which they appear.

IMPORTANT! ON ALL ORDERS, PLEASE INCLUDE PART NAME AND STYLE OF MACHINE FOR WHICH PART IS ORDERED.

USE GENUINE NEEDLES AND REPAIR PARTS

Success in the operation of these machines can be secured only with genuine UNION SPECIAL Needles and Repair Parts as furnished by the Union Special Corporation, its subsidiaries and authorized distributors. They are designed according to the most approved scientific principles, and are made with utmost precision. Maximum efficiency and durability are assured.

Genuine needles are packaged with labels marked *Union Special*®. Genuine repair parts are stamped with the Union Special trademark, U S Emblem. Each trademark is your guarantee of the highest quality in materials and workmanship.

TERMS

Prices are net cash and subject to change without notice. All shipments are forwarded f. o. b. shipping point. Parcel Post shipments are insured unless otherwise directed. A charge is made to cover postage and insurance.

OILING AND THREADING

The oil has been drained from the machine before shipping and the reservoir must be filled before beginning to operate. Use a straight mineral oil with a Saybolt viscosity of 90 to 125 seconds at 100° Fahrenheit.

Oil is filled at the spring cap in the top cover and the level is checked at the sight gauge on the front of the machine. The oil level should be maintained between the red lines on the gauge. The capacity of the oil reservoir is 12 ounces.

The machine is automatically lubricated and no oiling other than keeping the main reservoir filled is necessary.

A daily check before the morning start should be made and oil added if required. Oil which has gone through the machine is filtered and pumped back into the main reservoir making too frequent oilings unnecessary. Excessive oil in the main reservoir may be drained at the plug screw in the main frame directly under the handwheel.

On the next page is a picture showing the manner in which the 52900 Styles covered in this catalog are threaded. The spreader and looper threading has been enlarged for clarity.

THREADING AND OILING DIAGRAM

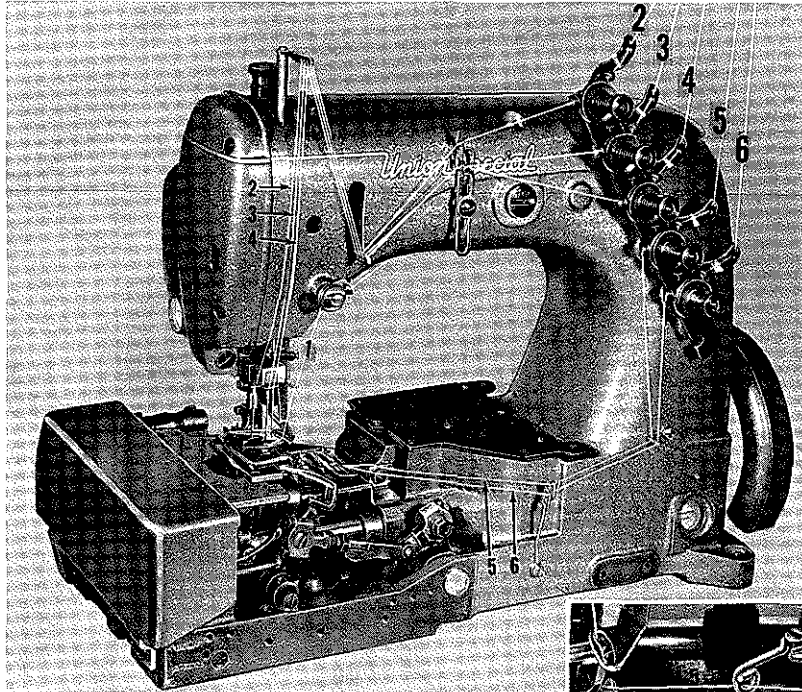

FOR STYLES 52900 BF, EG, BH, BL, BM, BN

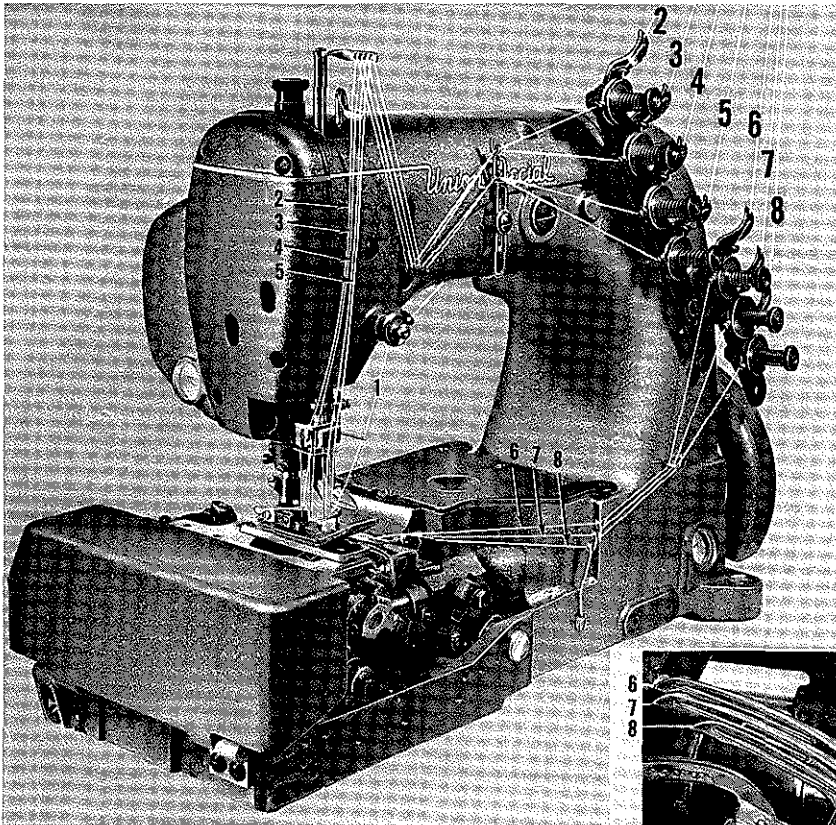
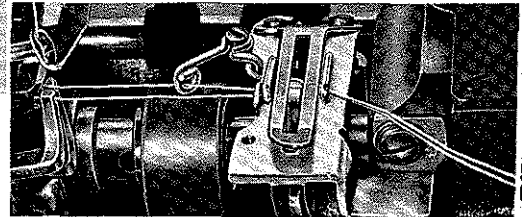

FOR STYLE 52900 BP

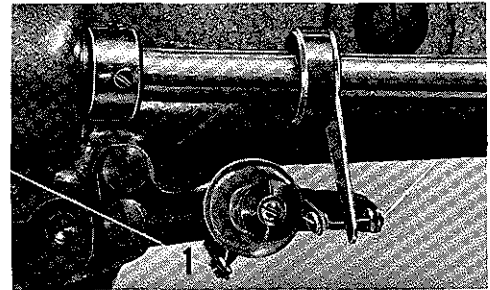

FOR ALL STYLES IN CLASS 52900

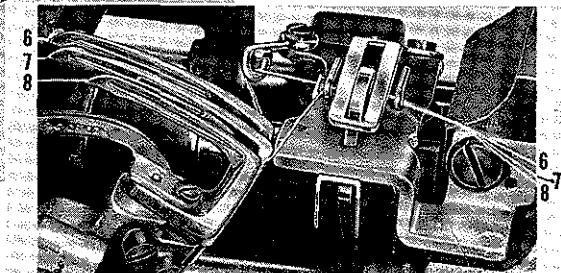

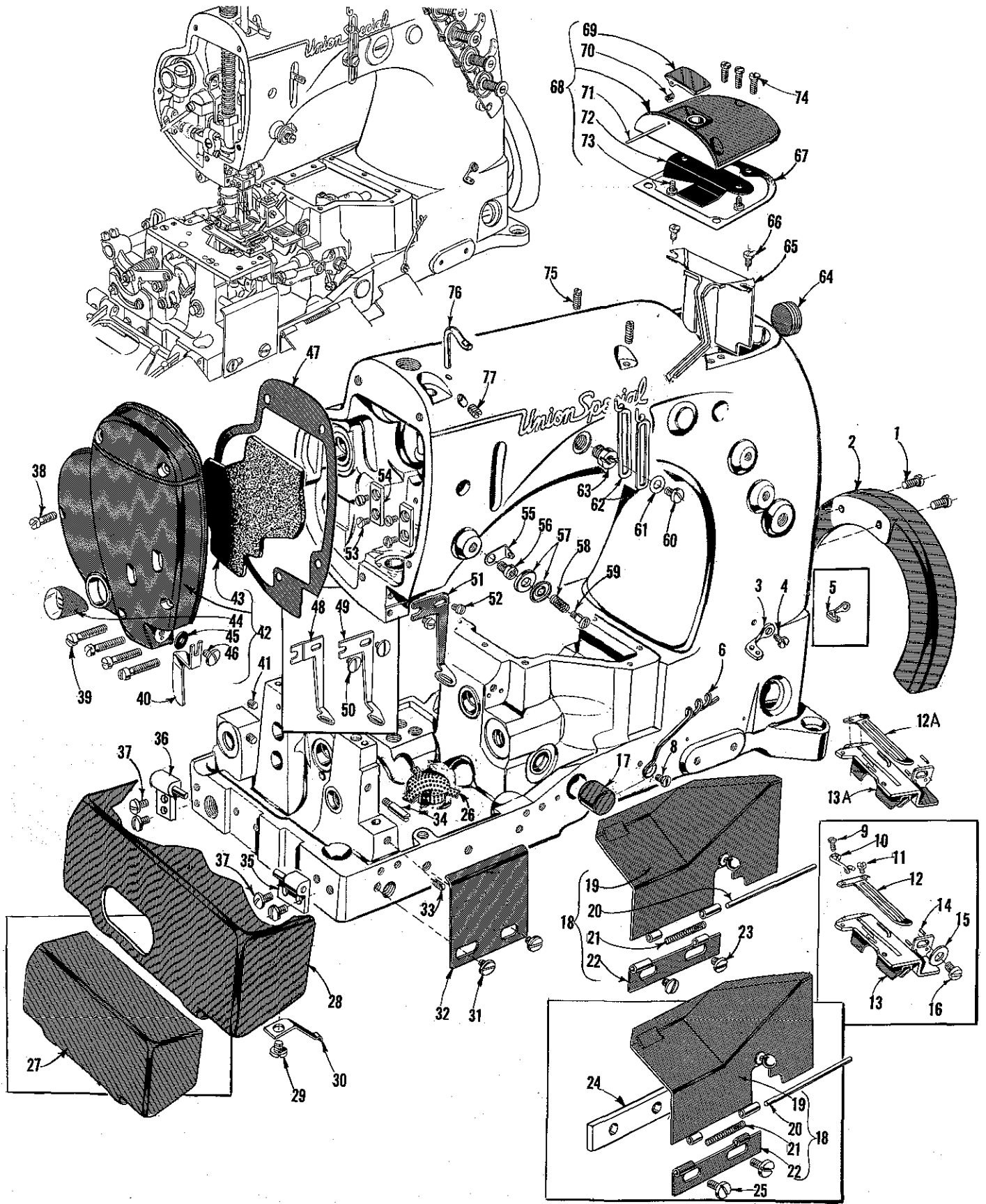

MAIN FRAME, CAST-OFF PLATE, MISCELLANEOUS COVERS AND PLATES

Ref. No.	Part No.	Description	Amt. Req.
1	93	Screw	2
2	BB21375 AH	Belt Guard	1
3	158 B	Thread Eyelet, for all Styles except 52900 BP	1
4	98 A	Screw	1
5	158 A	Thread Eyelet, for Style 52900 BP	1
6	52958 G	Frame Thread Eyelet	1
8	98 A	Screw	1
9	22768	Screw	1
10	52958	Looper Thread Control Pull-off Wire	1
11	28	Screw	1
12	52904	Cast-off Wire, for all Styles except 52900 BM	1
12A	52904 A	Cast-off Wire, for Style 52900 BM	1
13	52957	Cast-off Plate, for all Styles except 52900 BM	1
13A	52957 A	Cast-off Plate, for Style 52900 BM	1
14	50-216 Blk.	Dowel Pin	2
15	21657 E	Washer	1
16	22528	Screw	1
17	52942 Y	Looper Rocker Shaft Synchronizing Stud	1
18	57978	Front Cover and Chip Guard Assembly	1
19	57978 A	Front Cover	1
20	52978 U	Hinge Pin	1
21	39158 U	Spring	1
22	52978 T	Hinge	1
23	22730	Screw, for all Styles except 52900 BP	2
24	52978 W	Chip Guard Spacer, for Style 52900 BP	1
25	22548	Screw, for Style 52900 BP	2
26	51493 BK	Lint Filter Screen	1
27	52985	End Cover, for all Styles except 52900 BL	1
28	52985 A	End Cover, for Style 52900 BL	1
29	22711	Screw	1
30	52885 L	Spring	1
31	22730	Screw	2
32	52978 H	Front Cover, left	1
33	22560 B	Screw	1
34	22799 M	Screw	1
35	57885	Hinge Bracket, front	1
36	57885 B	Hinge Bracket, rear	1
37	22848	Screw	4
38	22572 A	Screw	1
39	294	Screw	4
40	52931 G	Presser Foot Toe Lifter, for Style 52900 BL	1
41	22597	Screw, for Style 52900 BL	2
42	52882 R	Head Cover	1
43	52882 Z	Felt Liner	1
44	52894 AN	Oil Gauge	1
45	52882 W	Gasket	1
46	22542	Screw	1
47	52882 S	Gasket	1
48	52944 S	Spreader Thread Guide, for Style 52900 BN	1
49	52944 D	Spreader Thread Guide, for Style 52900 BP	1
50	22542	Screw, for Style 52900 BP	2
51	52944 A	Spreader Thread Guide, for Styles 52900 BF, BG, BH, BL, BM, BR	1
52	90	Screw, for all Styles except 52900 BP	2
53	22513	Screw	4
54	35731 A	Presser Bar Connection Guide Plate	2
55	35582 B	Thread Guide	1
56	22517 C	Spreader Thread Tension Screw, front	1
57	15438 B	Tension Disc	2
58	15438 C	Tension Spring, front	1
59	15438 D	Stud	1
60	22848	Screw	1
61	20	Washer	1
62	539	Eyelet	2
63	22889 A	Adaptor Plug Screw	1
64	22539 D	Plug Screw	1
65	56382 AC	Needle Lever Bearing Oiler and Baffle Plate Assembly	1
66	90	Screw	2
67	52882 P	Gasket	1
68	52882 AD	Chamber Cover	1
69	39582 L	Oil Cap	1
70	52882 AC	Oil Cap Torsion Spring	1
71	50-789 Blk.	Oil Cap Hinge Pin	1
72	52882 AA	Drip Plate	1
73	90	Screw	2
74	22541 B	Screw	3
75	719	Screw	2
76	95	Screw	1
77	57770	Pull-off Wire	1

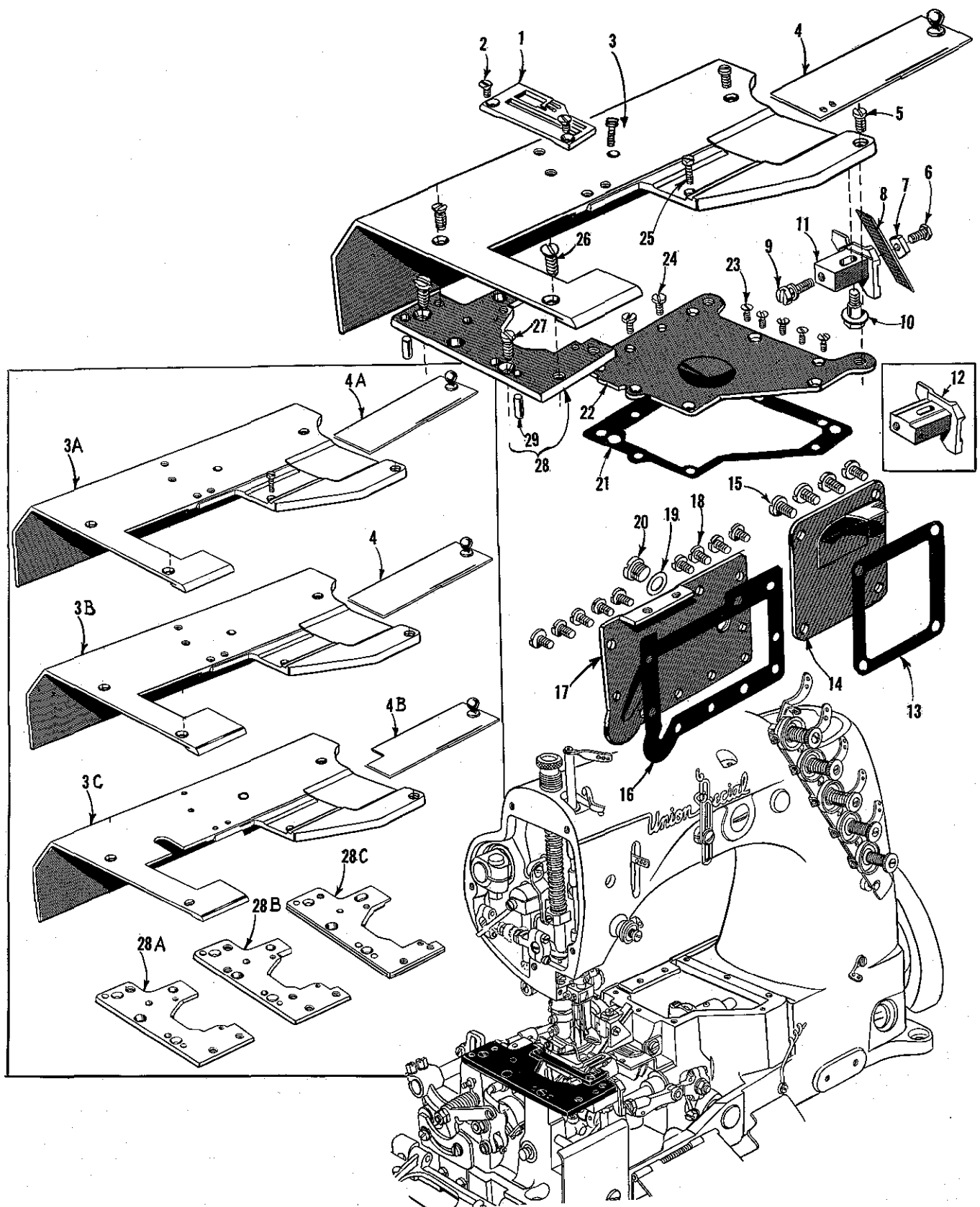

LOWER KNIFE PARTS, CLOTH PLATES AND MISCELLANEOUS COVERS

<u>Ref. No.</u>	<u>Part No.</u>	<u>Description</u>	<u>Amt. Req.</u>
1		Throat Plate (See Pages 37, 39, 41) -----	1
2	87	Screw-----	2
3	52901 L	Cloth Plate, for Style 52900 BL-----	1
3A	52901 M	Cloth Plate, for Style 52900 BP-----	1
3B	52901 J	Cloth Plate, for Styles 52900 BF, BG, BH, BN, BR-----	1
3C	52901 K	Cloth Plate, for Style 52900 BM-----	1
4	57902	Cloth Plate Sliding Cover, for Styles 52900 BF, BG, BH, BL, BN, BR-----	1
4A	52902 C	Cloth Plate Sliding Cover, for Style 52900 BP-----	1
4B	52902 B	Cloth Plate Sliding Cover, for Style 52900 BM-----	1
5	22839 C	Screw-----	2
6	22588 A	Screw-----	1
7	52950 H	Lower Knife Holder Plate-----	1
8	52949 A	Knife, lower-----	1
9	22568	Screw;-----	1
10	35766	Stud-----	1
11	52950 A	Lower Knife Holder Block, for all Styles except 52900 BP-----	1
12	52950 B	Lower Knife Holder Block, for Style 52900 BP-----	1
13	52882 U	Gasket-----	1
14	52882 AF	Crank Chamber Cover-----	1
15	22548	Screw;-----	4
16	52982 E	Gasket-----	1
17	52982 D	Oil Reservoir Back Cover-----	1
18	22848	Screw-----	9
19	41394 A	Gasket-----	2
20	22733 B	Screw-----	1
21	51382 A	Gasket-----	1
22	52982 F	Oil Reservoir Top Cover-----	1
23	22524	Screw-----	5
24	22585 A	Screw-----	2
25	22585 R	Screw-----	2
26	80	Screw-----	2
27	22839	Screw-----	2
28	52980 C	Throat Plate Support, for Style 52900 BL-----	1
28A	52980	Throat Plate Support, for Styles 52900 BF, BG, BH, BN, BR-----	1
28B	52980 A	Throat Plate Support, for Style 52900 BM-----	1
28C	51380 A	Throat Plate Support, for Style 52900 BP-----	1
29	51280 J	Dowel Pin-----	2

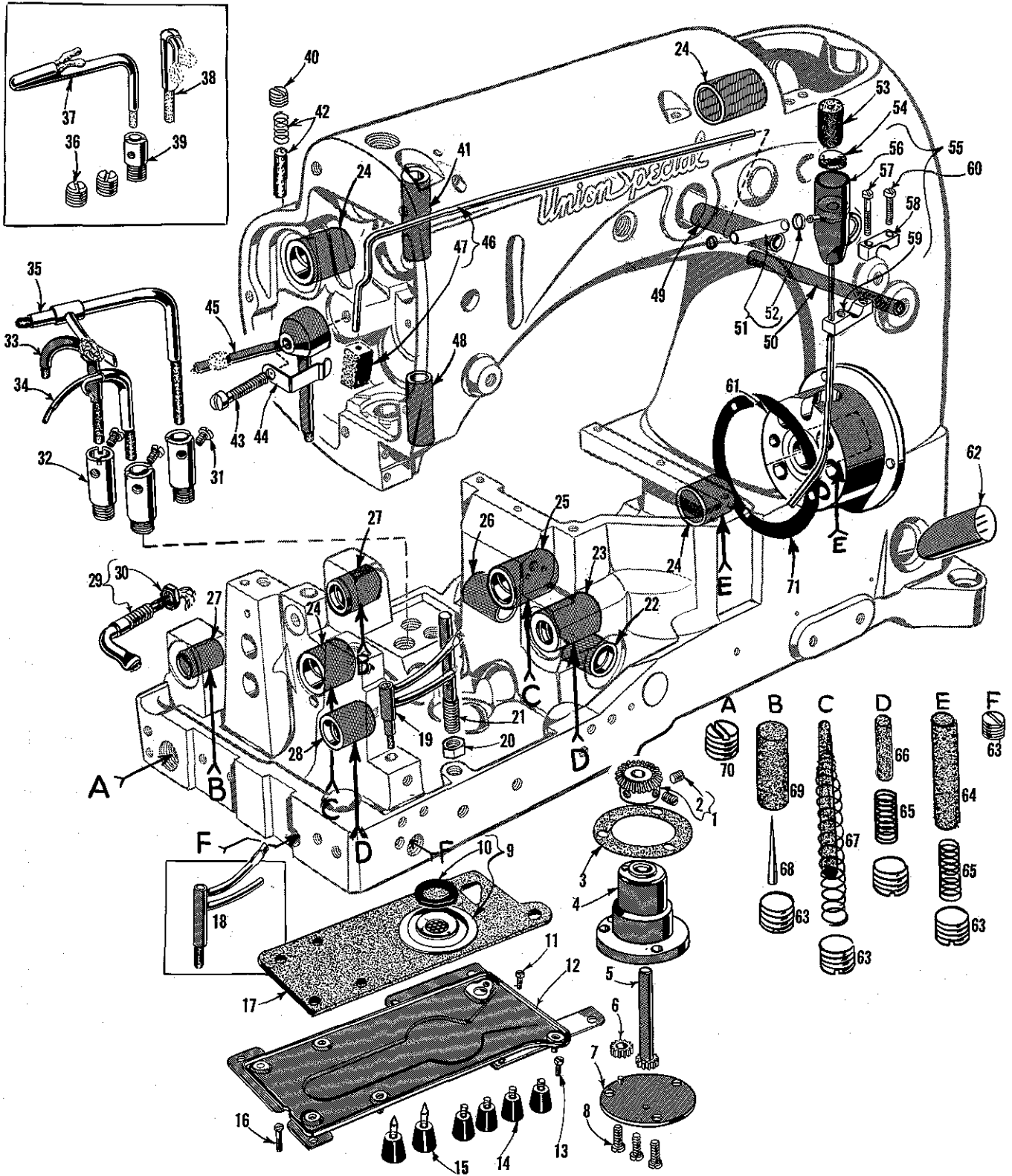

MAIN FRAME, BUSHINGS AND MISCELLANEOUS PARTS

<u>Ref. No.</u>	<u>Part No.</u>	<u>Description</u>	<u>Amt. Req.</u>
1	51493 BQ	Pump Driven Gear-----	1
2	531	Screw-----	2
3	643-127 Blk.	Gasket-----	1
4	51493 AG	Oil Pump Housing-----	1
5	51493 D	Oil Pump Driving Shaft-----	1
6	51493 E	Driving Shaft Gear-----	2
7	51493 AH	Oil Pump Housing Cover-----	1
8	22569 B	Screw-----	3
9	51493 BH	Filter Cap Assembly-----	1
10	51493 BJ	Washer, sponge rubber-----	1
11	22645 H-64	Screw-----	1
12	51493 AZ	Oil Pan Base Plate, for all Styles except 52900 BP-----	1
	51493 BB	Oil Pan Base Plate, for Style 52900 BP-----	1
13	22823 A	Screw-----	1
14	39595	Mounting Isolators-----	4
15	51295 B	Mounting Isolators-----	2
16	22823 B	Screw-----	1
17	51493 BG	Base Plate Oil Pad-----	1
18	52994 AG	Oil Tube, for looper rocker and left ball joint, for Style 52900 BP-----	1
19	52894 AK	Oil Tube, for looper rocker and left ball joint, for all Styles except 52900 BP--	1
20	258	Nut-----	1
21	15455	Lower Knife Holder Pin Support-----	1
22	52942 W	Looper Drive Lever Shaft Bushing, front-----	1
23	52944 U	Looper Rocker Shaft Bushing, right-----	1
24	52890 C	Main Shaft Bushing, left, inner right, and Rocker Shaft Bushing, left, upper right-----	4
25	51290 T	Main Shaft Bushing, middle-----	1
26	52942 X	Looper Drive Lever Shaft Bushing, rear-----	1
27	52836 P	Feed Rocker Shaft Bushing-----	2
28	52836 R	Looper Rock Shaft Bushing, left-----	1
29	660-136	Oil Tube, for feed crank link-----	1
30	258 A	Nut-----	1
31	90	Screw, for Styles 52900 BF, BG, BH, BN, BP, BR-----	1
	90	Screw, for Style 52900 BL-----	3
	90	Screw, for Style 52900 BM-----	2
32	52894 AB	Oil Tube Holder, for Styles 52900 BF, BG, BH, BM, BN, BP, BR-----	1
	52894 AB	Oil Tube Holder, for Style 52900 BL-----	3
33	52894 AD	Oil Tube, for differential feed bar shaft, for Style 52900 BL-----	1
34	52794 G	Oil Tube, for feed lift and looper avoid eccentric, for all Styles except 52900 BM-----	1
35	52894 AE	Oil Tube, for differential feed bar guide, for Style 52900 BL-----	1
36	22571 B	Plug Screw, for Styles 52900 BF, BG, BH, BN, BP, BR-----	2
	22571 B	Plug Screw, for Style 52900 BM-----	1
37	52994 AA	Oil Tube, for feed lift, for Style 52900 BM-----	1
38	52994 AC	Oil Tube, for upper feed lift and looper avoid, for Style 52900 BM-----	1
39	52994 AD	Oil Tube Holder, for Style 52900 BM-----	1
40	22706 A	Plug Screw-----	1
41	51254 C	Needle Bar Bushing, upper-----	1
42	666-99	Oil Wick, for spreader rocker shaft-----	1
43	294	Screw-----	1
44	52994 V	Oil Siphon Clamp-----	1
45	52894 K	Oil Tube Assembly-----	1
46	52994 U	Oil Siphon Tube-----	1
47	666-214	Felt Lint Filter-----	1
48	52954 B	Needle Bar Bushing, lower-----	1
49	52883 R	Presser Foot Lifter Lever Bushing-----	1
50	21657 X	Tension Release Lever Shaft Bushing-----	1
51	51294 Y	Oil Tube Connection-----	1
52	21212	Oil Siphon Connection Locking Ring-----	2
53	666-201	Felt Plug-----	1
54	666-209	Felt Plug-----	1
55	51294 U	Oil Siphon Assembly-----	1
56	643-263 Blk.	Siphon-----	1
57	22729 B	Screw-----	1
58	51294 K	Clamp, upper-----	1
59	28-182 Blk.	Clamp, lower-----	1
60	22729 A	Screw-----	1
61	52891 B	Crankshaft Bushing Housing, including bushing-----	1
62	50-648 Blk.	Lucite Oil Gauge-----	1
63	22571 A	Plug Screw-----	18
64	666-114	Oil Wick, for right main shaft bearing-----	2
65	35178 D	Spring-----	4
66	666-65	Oil Wick, for looper rocker shaft-----	2
67	666-118	Oil Wick, for left main shaft bearing-----	2
68	666-179	Wedge Pin-----	2
69	666-111	Oil Wick, for feed rocker shaft-----	2
70	22539 H	Plug Screw-----	1
71	56390 E	Gasket, for crankshaft bearing housing-----	1

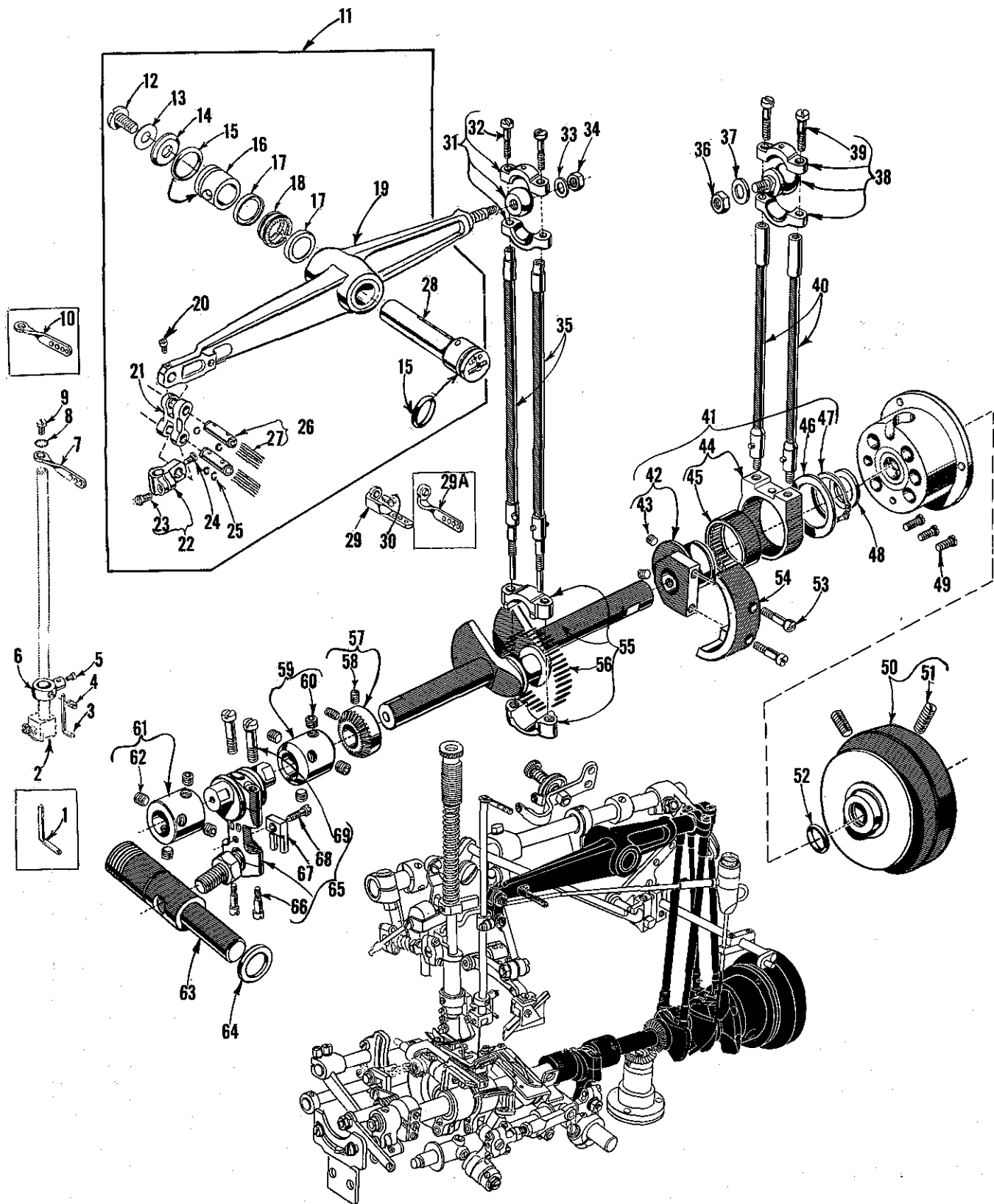

CRANKSHAFT, NEEDLE LEVER AND LOOPER DRIVING PARTS

<u>Ref. No.</u>	<u>Part No.</u>	<u>Description</u>	<u>Amt. Req.</u>
1	52944 C	Thread Eyelet, for Style 52900 BP -----	1
2		Needle Bar Assembly (See Page 35) -----	1
3	41076 D	Thread Eyelet, for Styles 52900 BF, BG, BH, BL, BM, BN, BR -----	1
4	22743	Screw -----	1
5	73 A	Screw -----	1
6	52842 A	Needle Bar Finger Thread Eyelet Support -----	1
7	56958 A	Needle Bar Thread Eyelet, for Styles 52900 BF, BG, BH, BL, BM, BN, BR -----	1
8	652 C-9	Needle Bar Eyelet Lock Washer -----	1
9	22768	Screw -----	1
10	54158 A	Needle Bar Thread Eyelet, for Style 52900 BP -----	1
11	29348 AF	Needle Lever Assembly -----	1
12	22586 R	Screw -----	1
13	51250 F	Gasket -----	1
14	51250 D	Washer -----	1
*15	660-212	Oil Seal Ring -----	2
16	56350 E	Needle Lever Thrust Collar -----	1
17	56350 F	Thrust Washer -----	2
18	660-614	Temper Load Ring -----	1
19	56315 A	Needle Lever -----	1
20	77	Screw -----	1
21	56354 D	Needle Bar Link -----	1
22	51254 K	Needle Bar Connection -----	1
23	22562 A	Screw -----	1
24	22564	Screw -----	1
25	660-215	Retaining Ring -----	4
26	52336 A	Link Pin -----	2
27	WO-3	Columbia Yarn, 6 strands -----	-
28	56350 D	Needle Lever Stud -----	1
29	56958	Needle Lever Eyelet, for Styles 52900 BF, BG, BH, BL, BM, BN, BR -----	1
29A	54158	Needle Lever Eyelet, for Style 52900 BP -----	1
30	22768	Screw -----	1
31	29066 R	Needle Lever Connecting Rod and Upper Bearing Assembly -----	1
32	22559 G	Screw -----	2
33	51216 N	Washer -----	1
	51216 P	Nut -----	1
35	51216 G	Needle Lever Connecting Rod -----	2
36	18	Nut -----	1
37	HA20 A	Washer -----	1
38	52952 B	Spreader Connecting Rod Ball Joint, upper -----	1
39	22559 G	Screw -----	2
40	52916	Connecting Rod -----	2
41	29126 CR	Spreader Drive Eccentric Assembly -----	1
42	52951	Spreader Driving Eccentric, .382 inch throw -----	1
43	95	Screw -----	2
44	52951 A	Connecting Rod Bearing -----	1
45	660-244	Needle Bearing -----	1
46	52951 B	Retaining Washer -----	1
47	660-246	Tru-Arc Ring -----	1
48	52951 C	Spacing Washer -----	1
49	22569 B	Screw -----	3
50	52921 B	Pulley -----	1
51	22894 G	Screw -----	2
52	660-202	Oil Seal Ring -----	1
53	22587 H	Screw -----	2
54	52947 A	Counterweight -----	1
55	29476 HW	Crankshaft Assembly, for Styles 52900 BN, BP, .990 inch throw -----	1
	29476 HL	Crankshaft Assembly, for Styles 52900 BF, BG, BH, BL, BM, BR, .910 inch throw -----	1
56	51216 M	Needle Bearing -----	28
57	51493 BP	Pump Driving Gear -----	1
58	22560 B	Screw -----	2
59	52943 L	Collar -----	1
60	22894 X	Screw -----	4
61	56343 D	Collar -----	1
62	22894 X	Screw -----	4
63	52942 A	Looper Drive Lever Rocker Shaft -----	1
64	52951 C	Spacing Washer -----	1
65	29476 LE	Looper Driving Lever Crank Assembly -----	1
66	22729 D	Screw, lower -----	2
67	51243 C	Ball Stud Guide -----	1
68	22729 D	Screw -----	1
69	22587	Screw, upper -----	2

* Det. No. 15 is not a component of part No. 29348 AF needle lever assembly.

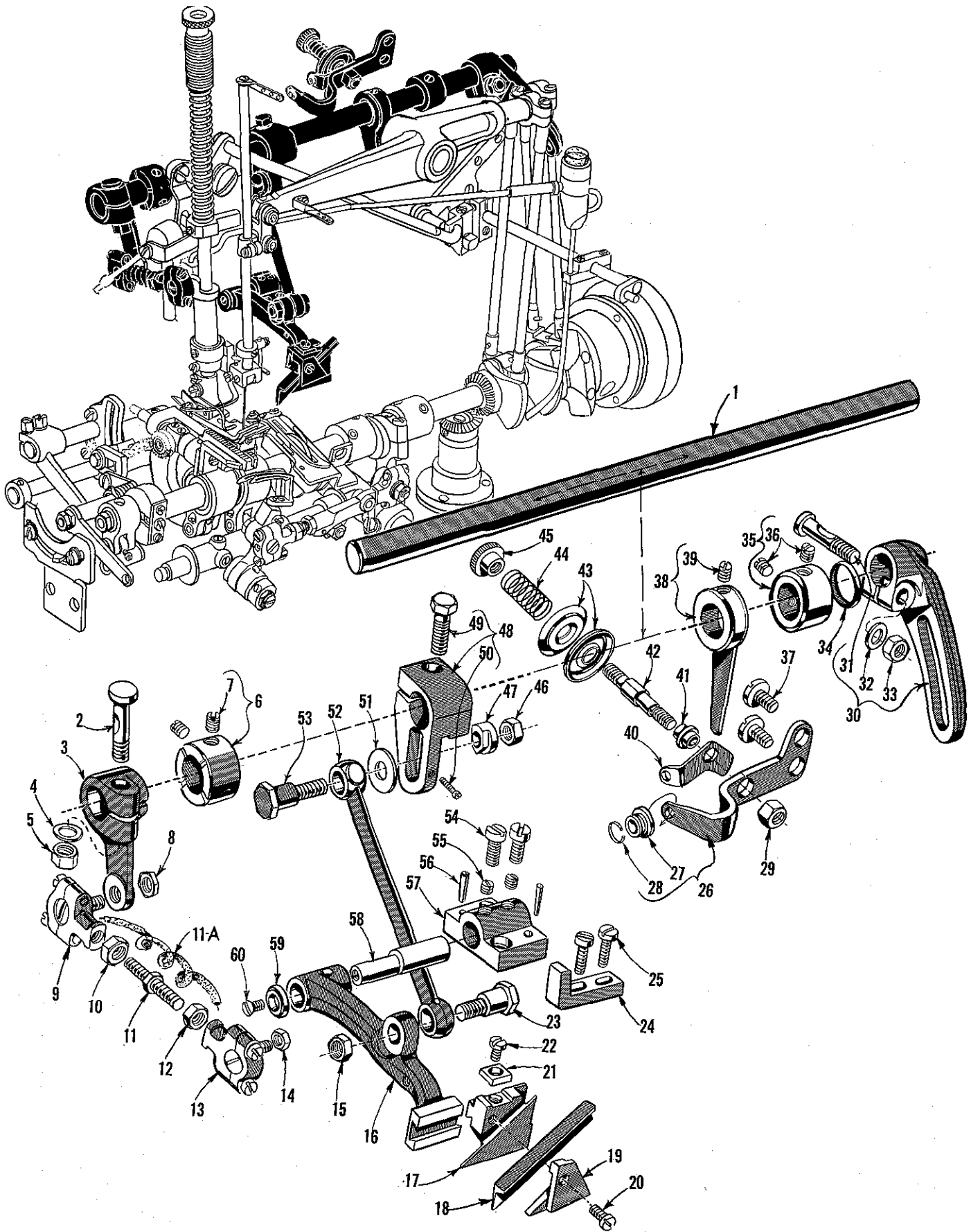

UPPER KNIFE AND SPREADER DRIVE MECHANISM

<u>Ref. No.</u>	<u>Part No.</u>	<u>Description</u>	<u>Amt. Req.</u>
1	52849	Spreader Rocker Shaft -----	1
2	55235 D	Screw -----	1
3	52849 B	Rocker Shaft Arm -----	1
4	6042 A	Washer-----	1
5	55235 E	Nut -----	1
6	51147	Collar-----	1
7	95	Screw-----	2
8	15037 A	Nut -----	1
9	52848 C	Spreader Connecting Rod Ball Joint, rear -----	1
10	269	Nut, left thread -----	1
11	51240 D	Spreader Connecting Rod -----	1
11A	CL21	Oil Wick-----	1
12	18	Nut, right thread -----	1
13	52848 B	Spreader Connecting Rod Ball Joint, front-----	1
14	12934 A	Nut -----	1
15	258	Nut -----	1
16	52973 X	Upper Knife Lever-----	1
17	52973 Z	Knife Holder Block -----	1
18	52970 E	Knife, upper -----	1
19	52973 T	Knife Clamp, upper-----	1
20	97	Screw -----	1
21	52973 S	Knife Holder Block Clamp -----	1
22	90	Screw -----	1
23	22857 B	Screw -----	1
24	52973 Q	Upper Knife Lever Thrust Bracket -----	1
25	22596	Screw -----	2
26	52855 A	Spreader Thread Pull-Off Eyelet -----	1
27	668-25	Steel Eyelet -----	1
28	668-28	Locking Ring -----	1
29	43266	Nut -----	1
30	52952 C	Spreader Thread Rock Shaft Lever -----	1
31	55235 D	Screw-----	1
32	6042 A	Washer -----	1
33	55235 E	Nut -----	1
34	660-202	Oil Ring -----	1
35	52849 C	Spreader Rocker Shaft Oil Seal Collar -----	1
36	95	Screw-----	2
37	22872	Screw -----	2
38	52855 G	Spreader Thread Pull-Off Arm-----	1
39	95	Screw-----	1
40	51292 D	Tension Thread Eyelet -----	1
41	51292 A	Tension Post Ferrule-----	1
42	51292	Spreader Thread Tension Post -----	1
43	109	Spreader Thread Tension Disc -----	2
44	51292 F-5	Tension Spring, spreader -----	1
45	51292 C	Tension Nut -----	1
46	258	Nut -----	1
47	52973 L	Driving Lever Link Adjusting Nut -----	1
48	52973 U	Upper Knife Driving Lever -----	1
49	22811 B	Screw-----	1
50	22738 D	Screw-----	1
51	53636 C	Washer-----	1
52	52973 K	Driving Lever Link -----	1
53	22857 B	Screw -----	1
54	22517	Screw -----	2
55	22580	Screw -----	2
56	60077 K	Pin -----	2
57	52973 W	Upper Knife Lever Stud Support Bracket -----	1
58	52973 V	Upper Knife Lever Stud -----	1
59	129	Washer-----	1
60	22526	Screw -----	1

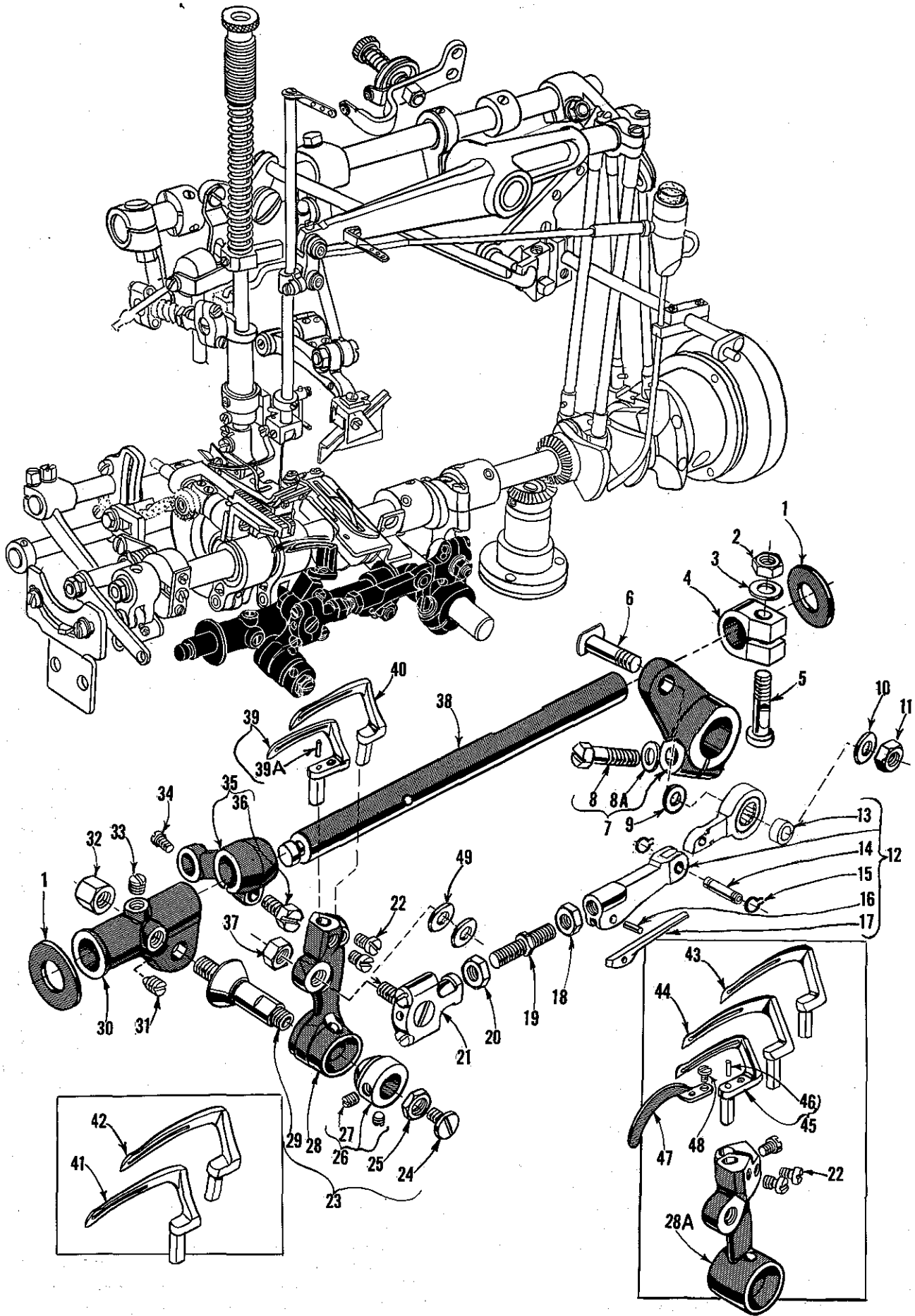

LOOPER ROCKER AND CONNECTING ROD PARTS

Ref. No.	Part No.	Description	Amt. Req.
1	51244 L	Thrust Washer-----	2
2	18	Nut-----	1
3	51216 N	Washer-----	1
4	51244 N	Looper Rocker Shaft Collar-----	1
5	55244 G	Locking Stud-----	1
6	52942 R	Looper Lever Stud-----	1
7	52942 P	Looper Drive Lever-----	1
8	22882 A	Screw-----	1
8A	51242 M	Washer-----	1
9	41355 U-4	Shim, .004 inch thick-----	as required
	41355 U-5	Shim, .005 inch thick-----	as required
	41355 U-6	Shim, .006 inch thick-----	as required
	41355 U-7	Shim, .007 inch thick-----	as required
	41355 U-8	Shim, .008 inch thick-----	as required
	41355 U-9	Shim, .009 inch thick-----	as required
10	20	Washer-----	1
11	18	Nut-----	1
12	56341 M	Looper Connecting Rod Section and Ball Joint Assembly, right----	1
13	56341 F	Ferrule-----	1
14	56341 E	Hinge Pin-----	1
15	660-310	Truarc Retaining Ring-----	2
16	50-458 Blk.	Spring Pin-----	1
17	56341 G	Spring-----	1
18	18	Nut, right thread-----	1
19	51240 E	Looper Connecting Rod-----	1
20	269	Nut, left thread-----	1
21	52841 A	Looper Connecting Rod Ball Joint, left-----	1
22	73	Looper Set Screw, for Style 52900 BP-----	3
-	73	Looper Set Screw, for all Styles except 52900 BP-----	2
23	29192 G	Looper Rocker Assembly, for Styles 52900 BF, BG, BH, BM, BN, BR-----	1
-	29192 S	Looper Rocker Assembly, for Style 52900 BP-----	1
-	29192 U	Looper Rocker Assembly, for Style 52900 BL-----	1
24	22829	Lock Nut Screw-----	1
25	258 A	Lock Nut-----	1
26	15465 F	Looper Rocker Cone-----	1
27	88	Set Screw-----	2
28	52913	Looper Rocker, for Styles 52900 BF, BG, BH, BM, BN, BR-----	1
-	73	Screw, for looper-----	2
-	52913 B	Looper Rocker, for Style 52900 BL-----	1
28A	52913 B	Looper Rocker, for Style 52900 BP-----	1
29	51745	Looper Rocker Cone Stud-----	1
30	51244	Looper Rocker Frame-----	1
31	96	Spot Screw-----	1
32	51246	Looper Rocker Stud Nut-----	1
33	98	Set Screw-----	1
34	22768	Screw-----	1
35	51244 B	Looper Rocker Shaft Arm-----	1
36	22519 H	Screw-----	1
37	18	Nut-----	1
38	51144	Looper Rocker Shaft-----	1
39	52808 E	Looper, front, for all Styles except 52900 BP-----	1
39A	1740	Pin-----	1
40	52909 A	Looper, back, for No. 5-8 gauge, Styles 52900 BF, BG, BH, BL, BM, BN, BR-----	1
41	52909 E-16	Looper, back, for Nos. 12-12 and 16-8 gauges, Styles 52900 BG, BH, BL, BM, BN, BR-----	1
42	52909 B-24	Looper, back, for No. 24-8 gauge, Style 52900 BG-----	1
43	52909 D	Looper, back, for Style 52900 BP-----	1
44	52908 F-1	Looper, middle, for Style 52900 BP-----	1
45	52908 D	Looper, front, for Style 52900 BP-----	1
46	1740	Pin-----	1
47	52910	Looper Needle Guard, for Style 52900 BP-----	1
48	73 A	Screw-----	1
49	20	Washer-----	2

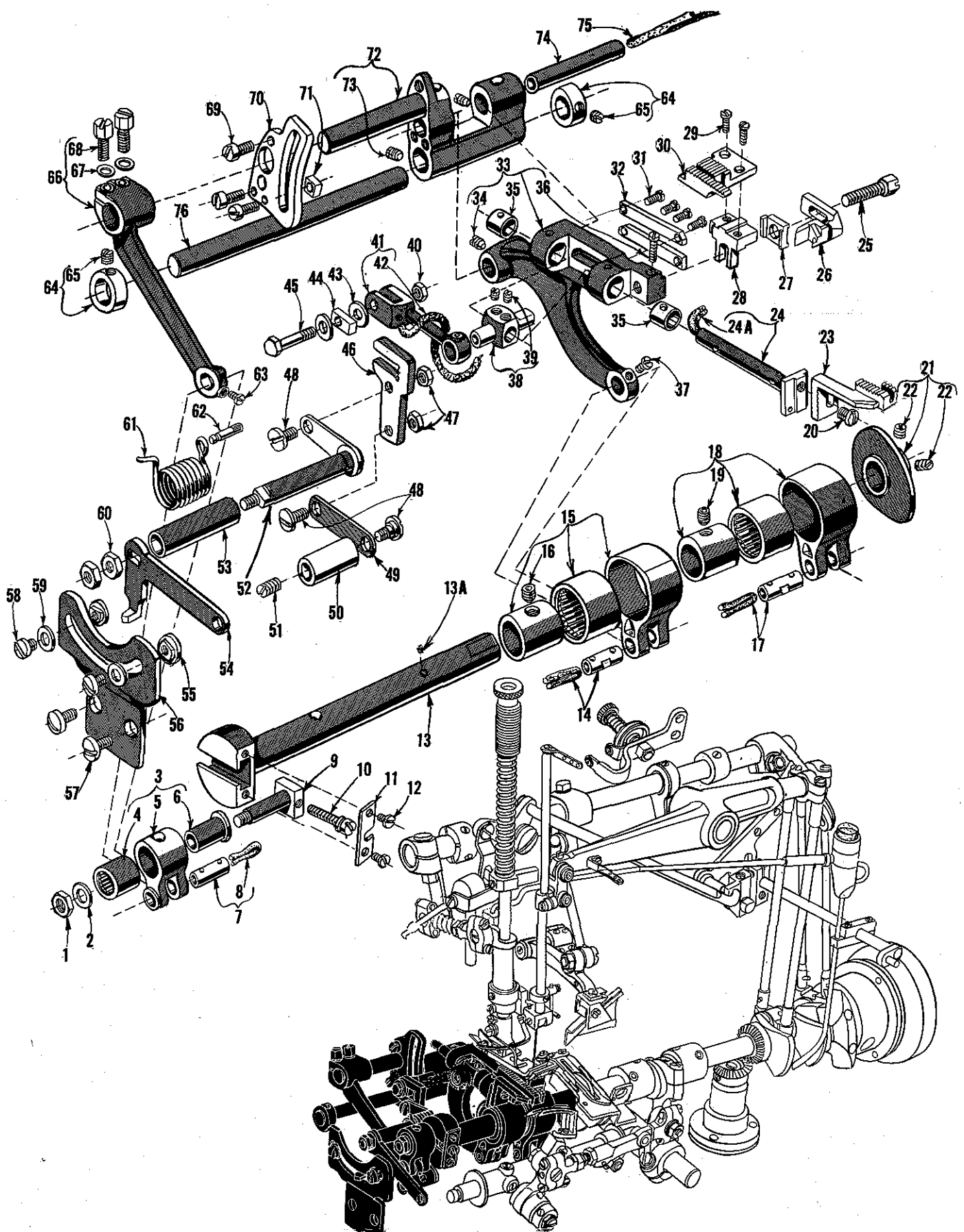

FOR STYLE 52900 BL ONLY
MAIN SHAFT AND DIFFERENTIAL FEED MECHANISM

Ref. No.	Part No.	Description	Amt. Req.
1	269	Nut, left thread-----	1
2	20	Washer-----	1
3	51236 E	Feed Crank Link Assembly -----	1
4	660-169	Needle Bearing-----	1
5	51236 D	Feed Crank Link-----	1
6	51236 F	Feed Crank Link Ferrule-----	1
7	51054	Link Pin-----	1
8	666-149	Oil Wick-----	1
9	51236 G	Feed Crank Stud-----	1
10	82	Stitch Regulating Screw-----	1
11	51236 B	Feed Crank Stud Cap-----	1
12	22768	Screw-----	2
13	52822 B	Main Shaft-----	1
13A	22801	Screw-----	1
14	51236 A	Link Pin-----	1
15	29476 DX	Feed Link Eccentric Assembly-----	1
16	22894 D	Screw-----	1
17	51236 A	Link Pin-----	1
18	29476 DX	Looper Avoid Eccentric Assembly-----	1
19	22894 D	Screw-----	1
20	90	Screw-----	1
21	52923 C	Take-up-----	1
22	22580	Set Screw-----	2
23		Differential Feed Dog (See Page 37)-----	1
24	52834 H	Differential Feed Bar-----	1
24A	CL21	Oil Wick-----	1
25	22519 J	Screw, for differential feed dog holder-----	1
26	52925 C	Needle Guard-----	1
27	52925 D	Needle Guard Holder-----	1
28	52953 A	Feed Dog Holder-----	1
29	22593	Screw-----	2
30		Main Feed Dog (See Page 37)-----	1
31	22593	Screw-----	4
32	39237 D	Differential Feed Bar Guide Plate-----	2
33	52834	Main Feed Bar-----	1
34	22560 B	Screw-----	1
35	39237 G	Bushing-----	2
36	22747	Feed Dog Height Adjusting Screw-----	1
37	77	Screw-----	1
38	39237	Differential Feed Bar Guide-----	1
39	22565 C	Screw-----	2
40	907	Nut-----	1
41	52835 V	Differential Feed Bar Driving Link-----	1
42	CL21	Oil Wick-----	1
43	51225 W	Washer-----	2
44	52835 S	Differential Feed Fork Block-----	1
45	22868 A	Screw-----	1
46	to 76	See following page	

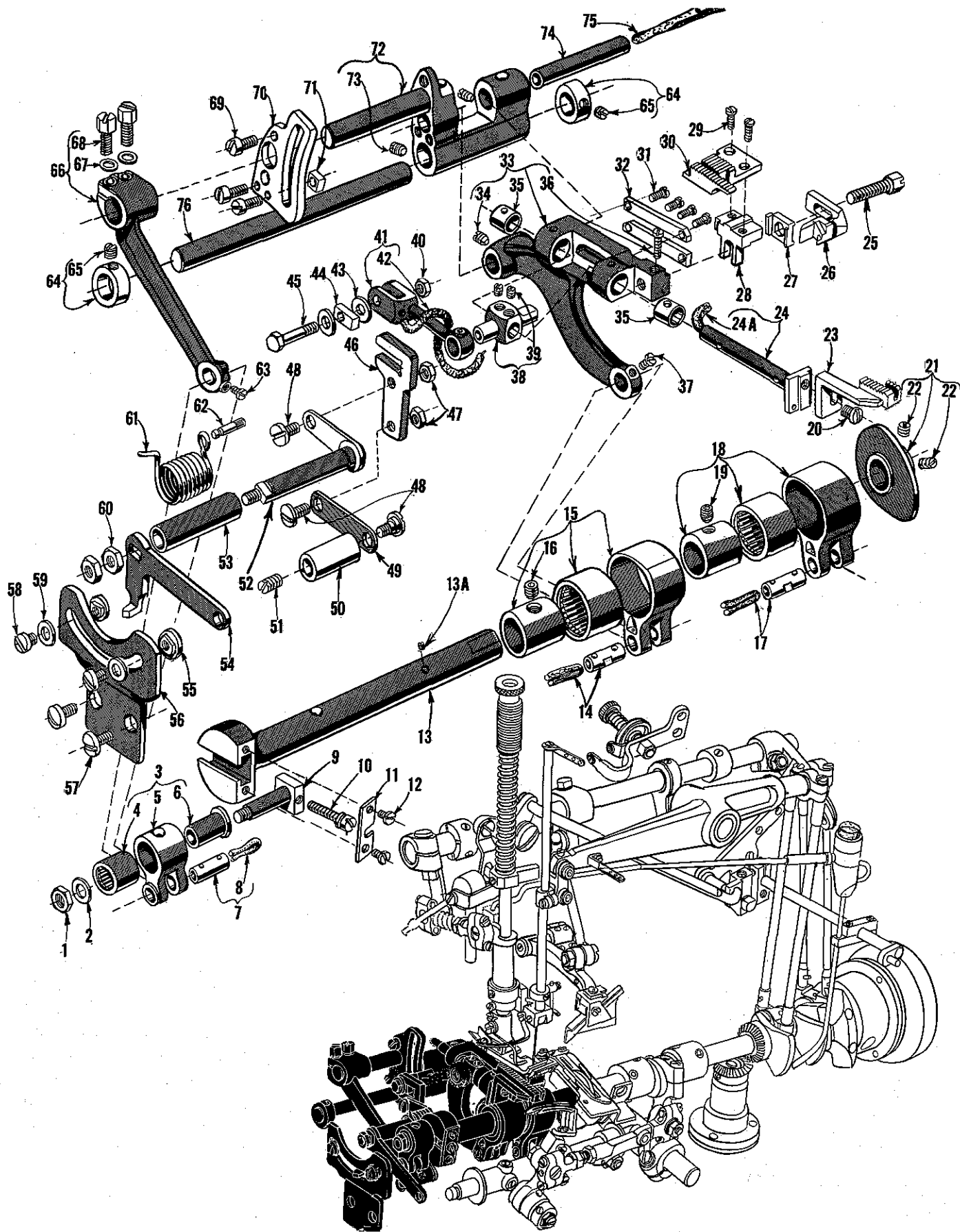

FOR STYLE 52900 BL ONLY

DIFFERENTIAL FEED MECHANISM PARTS

<u>Ref. No.</u>	<u>Part No.</u>	<u>Description</u>	<u>Amt. Req.</u>
1 to 45		See preceding page	
46	52835 Q	Differential Feed Fork-----	1
47	12934 A	Nut-----	2
48	22758 B	Screw-----	3
49	52835 G	Control Lever Link-----	1
50	52835 U	Pivot Stud Insert-----	1
51	719	Screw-----	1
52	51435	Control Lever, rear-----	1
53	51435 B	Control Lever Bushing-----	1
54	52835	Differential Feed Control Lever-----	1
55	43139 A	Indicator Stop-----	2
56	52835 N	Control Lever Stop Plate-----	1
57	22848	Screw-----	2
58	25 CC	Screw-----	2
59	8372 A	Indicator Stop Washer-----	2
60	9937	Nut-----	2
61	52835 K	Control Lever Spring-----	1
62	61267 G	Pin-----	1
63	77	Screw-----	1
64	482	Collar-----	2
65	98	Screw-----	2
66	52836 C	Feed Rocker Arm-----	1
67	51235 G	Washer-----	2
68	22519 C	Screw-----	2
69	22516	Screw-----	3
70	52836 H	Feed Rocker Segment Plate-----	1
71	57836 F-40	Sliding Block, marked "N", .2540 inch wide-----	1
-	57836 F-45	Sliding Block, marked "P", .2545 inch wide-----	1
-	57836 F-50	Sliding Block, marked "R", .2550 inch wide-----	1
72	52836	Feed Rocker-----	1
73	22894 P	Screw-----	2
74	39135	Feed Bar Shaft-----	1
75		Wool Yarn-----	1
76	8	Feed Rocker Shaft-----	1

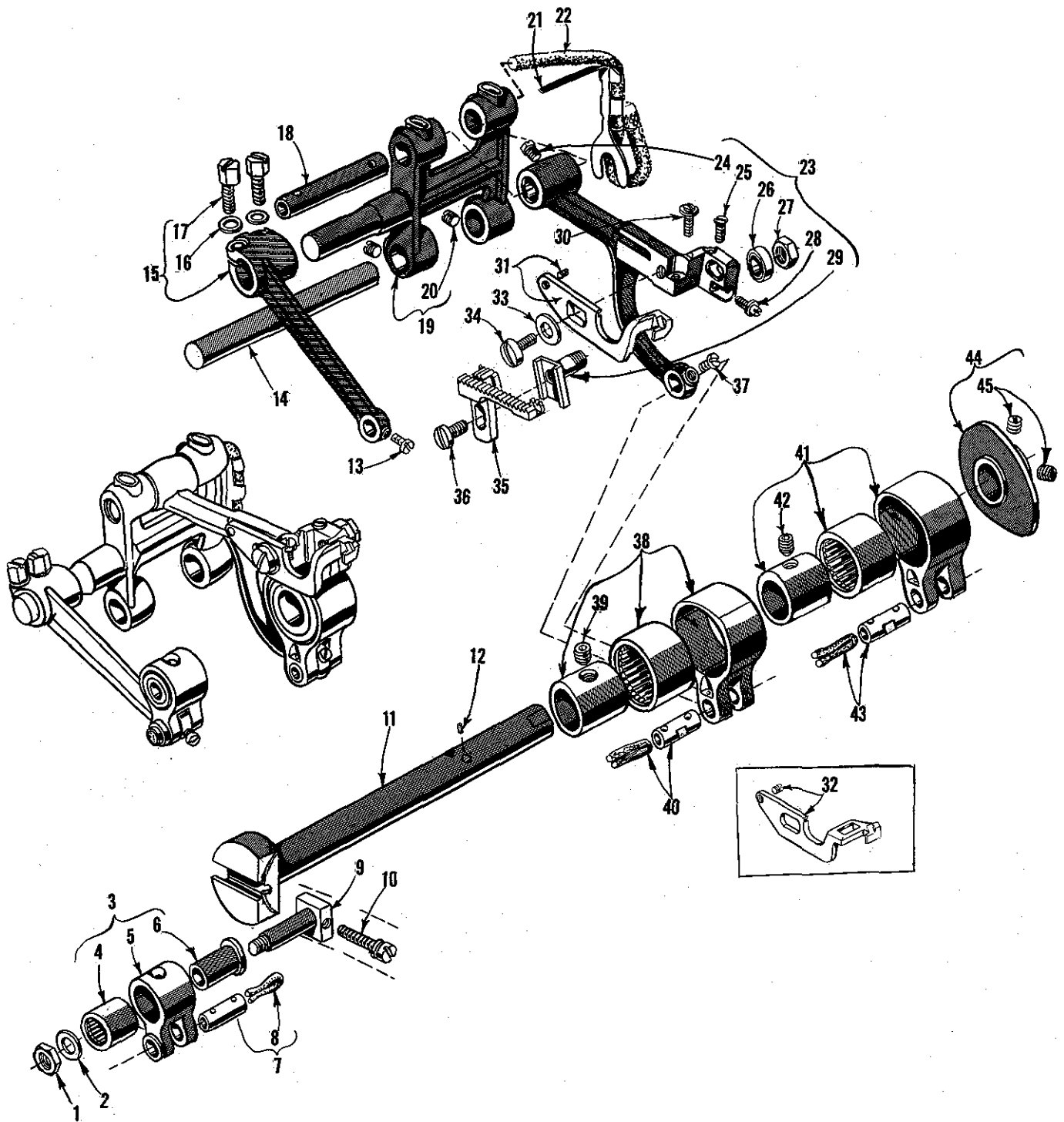

FOR STYLES 52900 BF, BG, BH, BN, BP, BR ONLY

MAIN SHAFT AND FEED MECHANISM

<u>Ref. No.</u>	<u>Part No.</u>	<u>Description</u>	<u>Amt. Req.</u>
1	269	Nut, left thread-----	1
2	20	Washer-----	1
3	51236 E	Feed Crank Link, complete-----	1
4	660-169	Needle Bearing-----	1
5	51236 D	Feed Crank Link-----	1
6	51236 F	Feed Crank Link Ferrule-----	1
7	51054	Link Pin-----	1
8	666-149	Oil Wick-----	1
9	51236 G	Feed Crank Stud-----	1
10	82	Stitch Regulating Screw-----	1
11	52922 C	Main Shaft-----	1
12	22801	Screw-----	1
13	77	Screw-----	1
14	8	Feed Rocker Shaft-----	1
15	51235 A	Feed Rocker Arm-----	1
16	51235 G	Washer-----	2
17	22519 C	Screw-----	2
18	51134 C	Feed Bar Shaft-----	1
19	51235	Feed Rocker-----	1
20	98	Screw-----	2
21	51134 R	Lubricating Felt Guard-----	1
22	51134 P	Lubricating Felt-----	1
23	51134 A	Tiltable Feed Bar-----	1
24	166	Screw-----	1
25	538	Feed Dog Height Adjusting Screw-----	1
26	51134 J	Feed Dog Holder Washer-----	1
27	258 A	Check Nut-----	1
28	22863	Feed Dog Holder Adjusting Screw-----	1
29	56334 E	Feed Dog Holder-----	1
30	22834	Needle Guard Adjusting Screw-----	1
31		Needle Guard (See Page 35)-----	1
32		Needle Guard (See Page 35)-----	1
33	51225 W	Washer-----	1
34	22585 B	Screw-----	1
35		Feed Dog (See Pages 37, 39, 41)-----	1
36	22528	Screw-----	1
37	77	Screw-----	1
38	29476 DR	Feed Lift Eccentric Assembly-----	1
39	22894 D	Screw-----	1
40	51236 A	Link Pin-----	1
41	29476 DX	Looper Avoid Eccentric Assembly-----	1
42	22894 D	Screw-----	1
43	51236 A	Link Pin-----	1
44	52923 C	Take-up-----	1
45	22580	Set Screw-----	2

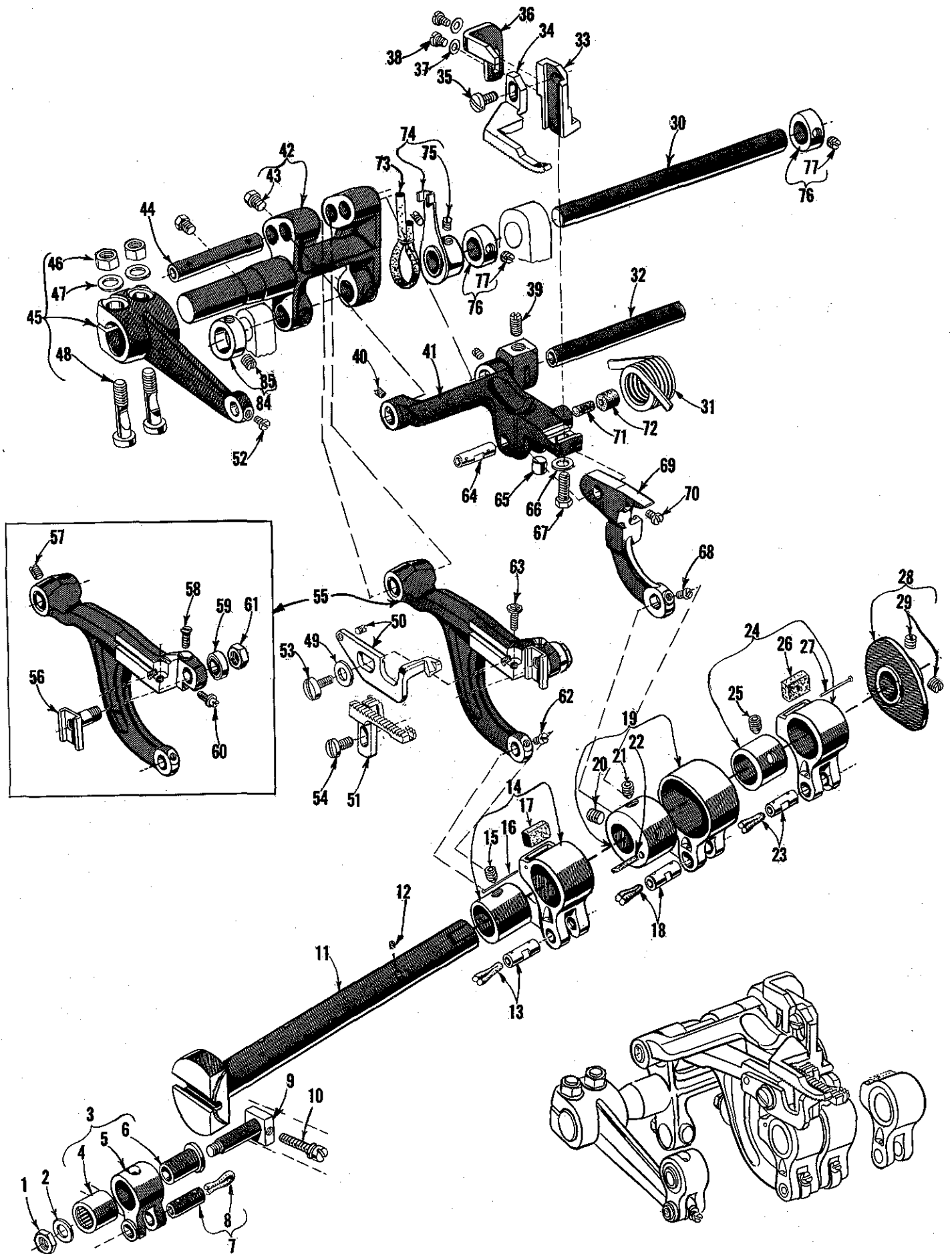

FOR STYLE 52900 BM ONLY

MAIN SHAFT AND TOP FEED MECHANISM

<u>Ref. No.</u>	<u>Part No.</u>	<u>Description</u>	<u>Amt. Req.</u>
1	269	Nut-----	1
2	20	Washer-----	1
3	51236 E	Feed Crank Link Assembly-----	1
4	660-169	Needle Bearing-----	1
5	51236 D	Feed Crank Link-----	1
6	51236 F	Feed Crank Link Ferrule-----	1
7	51054	Link Pin-----	1
8	666-149	Oil Wick-----	1
9	51236 G	Feed Crank Stud-----	1
10	82	Screw-----	1
11	52922 G	Main Shaft-----	1
12	22801	Screw-----	1
13	51236 A	Link Pin-----	1
14	29476 AR	Feed Lift Eccentric Assembly-----	1
15	22894 D	Screw-----	1
16	PI-18	Pin-----	1
17	666-82	Felt Wick-----	1
18	51236 A	Link Pin-----	1
19	29476 GM	Top Feed Lift Eccentric Assembly-----	1
20	22894 C	Screw, set-----	1
21	22894 D	Screw, spot-----	1
22	666-81	Felt Wick-----	1
23	51236 A	Link Pin-----	1
24	29476 BJ	Looper Avoid Eccentric Assembly-----	1
25	22894 D	Screw-----	1
26	666-82	Felt Wick-----	1
27	PI-18	Pin-----	1
28	52923 C	Looper Thread Take-up-----	1
	22580	Screw, set-----	2
	8	Feed Rocker Shaft-----	1
31	51134 N	Feed Bar Spring-----	1
32	51034 A	Feed Bar Shaft-----	1
33	52934 D	Top Feed Dog Holder-----	1
34		Top Feed Dog (See Page 39)-----	1
35	22528	Screw-----	1
36	K68719	Top Feed Lifter-----	1
37	21210 B	Washer-----	2
38	90	Screw-----	2
39	HA95	Screw-----	1
40	88 B	Screw-----	2
41	52934 A	Feed Bar, upper-----	1
42 to 77		See following page	

FOR STYLE 52900 BM ONLY

TOP FEED MECHANISM

<u>Ref. No.</u>	<u>Part No.</u>	<u>Description</u>	<u>Amt. Req.</u>
1 to 41		See preceding page	
42	52935	Feed Rocker-----	1
43	92127	Screw-----	2
44	51134 C	Feed Bar Shaft-----	1
45	51135 P	Feed Rocker Arm-----	1
46	55235 E	Nut-----	2
47	6042 A	Washer-----	2
48	55235 D	Stud-----	2
49	51225 W	Washer-----	1
50		Needle Guard (See Page 35)-----	1
51		Feed Dog (See Page 39)-----	1
52	77	Screw-----	1
53	22585 B	Screw-----	1
54	22528	Screw-----	1
55	52934	Feed Bar-----	1
56	51134 HA	Feed Dog Holder-----	1
57	22560 B	Screw-----	1
58	538	Screw-----	1
59	51134 J	Washer-----	1
60	22863	Screw-----	1
61	258	Nut-----	1
62	77	Screw-----	1
63	22834	Needle Guard Adjusting Screw-----	1
64	51134 V	Taper Pin-----	1
65	52934 C	Upper Feed Bar Stop-----	1
66	51216 N	Washer-----	1
67	22852	Screw-----	1
68	77	Screw-----	1
69	52934 B	Upper Feed Bar Arm-----	1
70	90	Screw-----	1
71	666-47	Felt-----	1
72	666-138	Felt-----	1
73	51134 T	Lubricating Felt-----	1
74	51135 R	Feed Rocker Shaft Collar and Lubricating Felt Support-----	1
75	98	Screw-----	2
76	14649	Collar-----	3
77	88	Screw-----	6

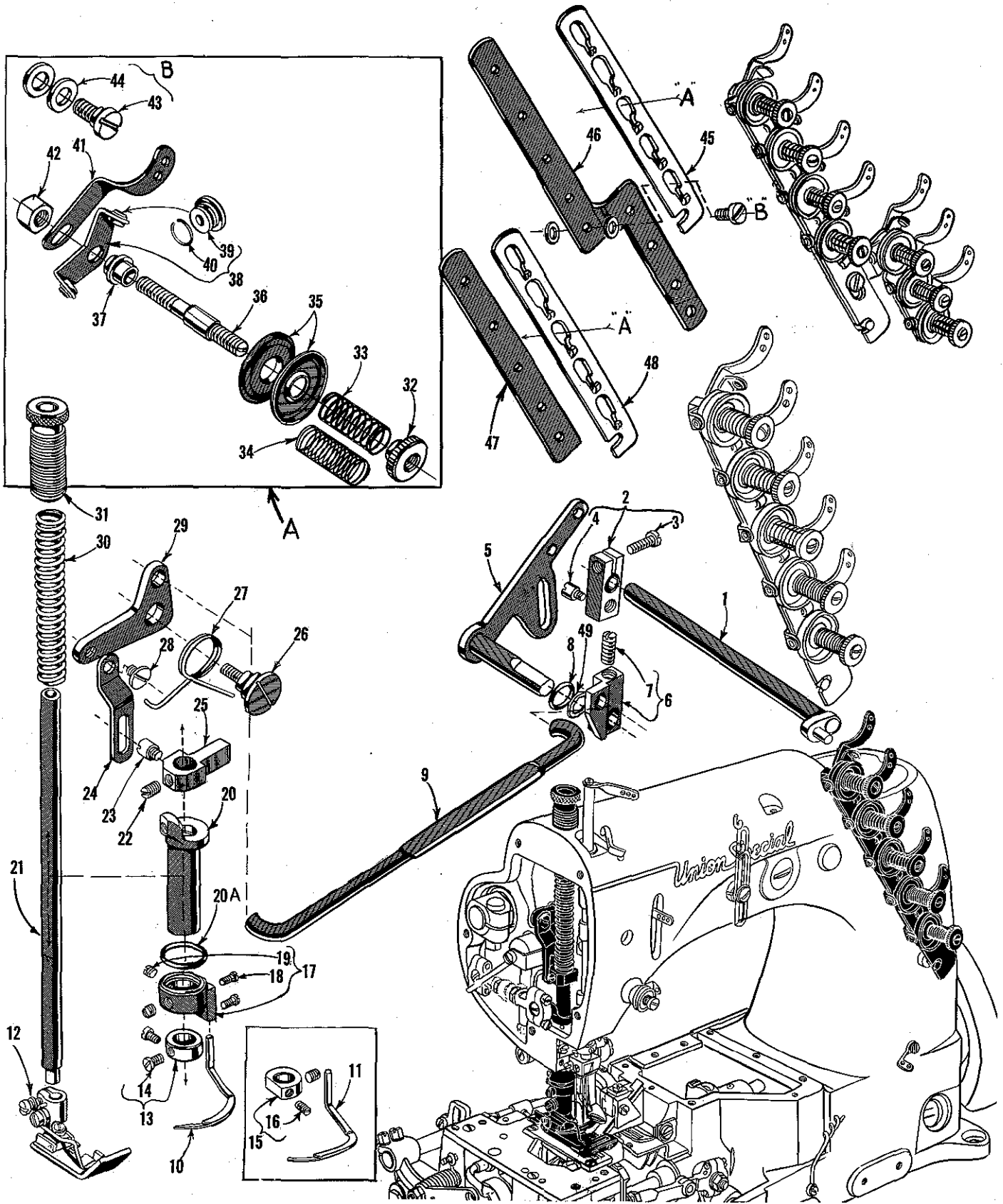

THREAD TENSION, LIFTER LEVER PARTS AND SPREADER HOLDING PARTS

<u>Ref. No.</u>	<u>Part No.</u>	<u>Description</u>	<u>Amt. Req.</u>
1	21657 W	Tension Release Lever Shaft -----	1
2	21657 Y	Tension Release Lever Connection -----	1
3	22596	Screw -----	1
4	402	Screw -----	1
5	51283 H	Presser Foot Lifter Lever -----	1
6	53783 N	Presser Foot Lifter Lever, internal -----	1
7	22537	Screw -----	1
8	660-207	Oil Ring, for presser foot lever -----	1
9	53783 M	Presser Foot Lifter Lever Connecting Rod -----	1
10	52945 M	Spreader, for all Styles except 52900 BP -----	1
11	52945 L	Spreader, for Style 52900 BP -----	1
12		Presser Foot (See Pages 37, 39, 41) -----	1
13	52888 B	Presser Bar Stop Collar, for all Styles except 52900 BM --	1
14	22562	Screw -----	2
15	K68042	Presser Bar Stop Collar, for Style 52900 BM -----	1
16	22565 C	Screw -----	2
17	52846 A	Spreader Holder -----	1
18	77 A	Screw -----	2
19	22894 W	Screw -----	2
20	52847	Spreader Holder Carrier and Lower Presser Bar Bushing--	1
20A	660-202	Oil Ring -----	1
21	53688	Presser Bar -----	1
22	531	Screw -----	1
23	402	Screw -----	1
24	53783 A	Lifter Lever Link -----	1
25	51257 M	Presser Bar Connection and Guide -----	1
26	22557 B	Screw -----	1
27	52883 S	Presser Foot Lifter Lever Bell Crank Spring -----	1
28	22758 C	Screw -----	1
29	53783 L	Presser Foot Lifter Lever Crank -----	1
30	51256 C	Presser Bar Spring -----	1
31	52889 A	Presser Spring Regulator -----	1
32	51292 C	Tension Nut, for Style 52900 BP -----	7
	51292 C	Tension Nut, for all Styles except 52900 BP -----	5
33	51292 F-8	Tension Spring, needle, for Style 52900 BP -----	4
	51292 F-8	Tension Spring, needle, for all Styles except 52900 BP ---	3
34	51292 F-2	Tension Spring, looper, for Style 52900 BP -----	3
	51292 F-2	Tension Spring, looper, for all Styles except 52900 BP ---	2
35	109	Tension Disc, for Style 52900 BP -----	14
	109	Tension Disc, for all Styles except 52900 BP -----	10
36	51292 G	Tension Post, for Style 52900 BP -----	7
	51292 G	Tension Post, for all Styles except 52900 BP -----	5
37	51292 A	Tension Post Ferrule, for Style 52900 BP -----	7
	51292 A	Tension Post Ferrule, for all Styles except 52900 BP -----	5
38	51292 D	Tension Post Eyelet, for Style 52900 BP -----	7
	51292 D	Tension Post Eyelet, for all Styles except 52900 BP -----	5
39	668-25	Eyelet Insert -----	10-14
40	668-28	Locking Ring -----	10-14
41	51491 C	Thread Lead-in Guide, for Style 52900 BP -----	7
	51491 C	Thread Lead-in Guide, for all Styles except 52900 BP ---	5
42	43266	Nut, for Style 52900 BP -----	6
	43266	Nut, for all Styles except 52900 BP -----	3
43	22598 C	Tension Release Stud, for Style 52900 BP -----	1
44	80557	Washer, for Style 52900 BP -----	2
45	21657 AM-5	Tension Disc Separator -----	1
46	51892	Tension Post Support, for Style 52900 BP -----	1
47	52992 A	Tension Post Support, for all Styles except 52900 BP -----	1
48	21657 AM-5	Tension Disc Separator -----	1
49	39552 C	Washer, for presser foot lifter lever, internal -----	1

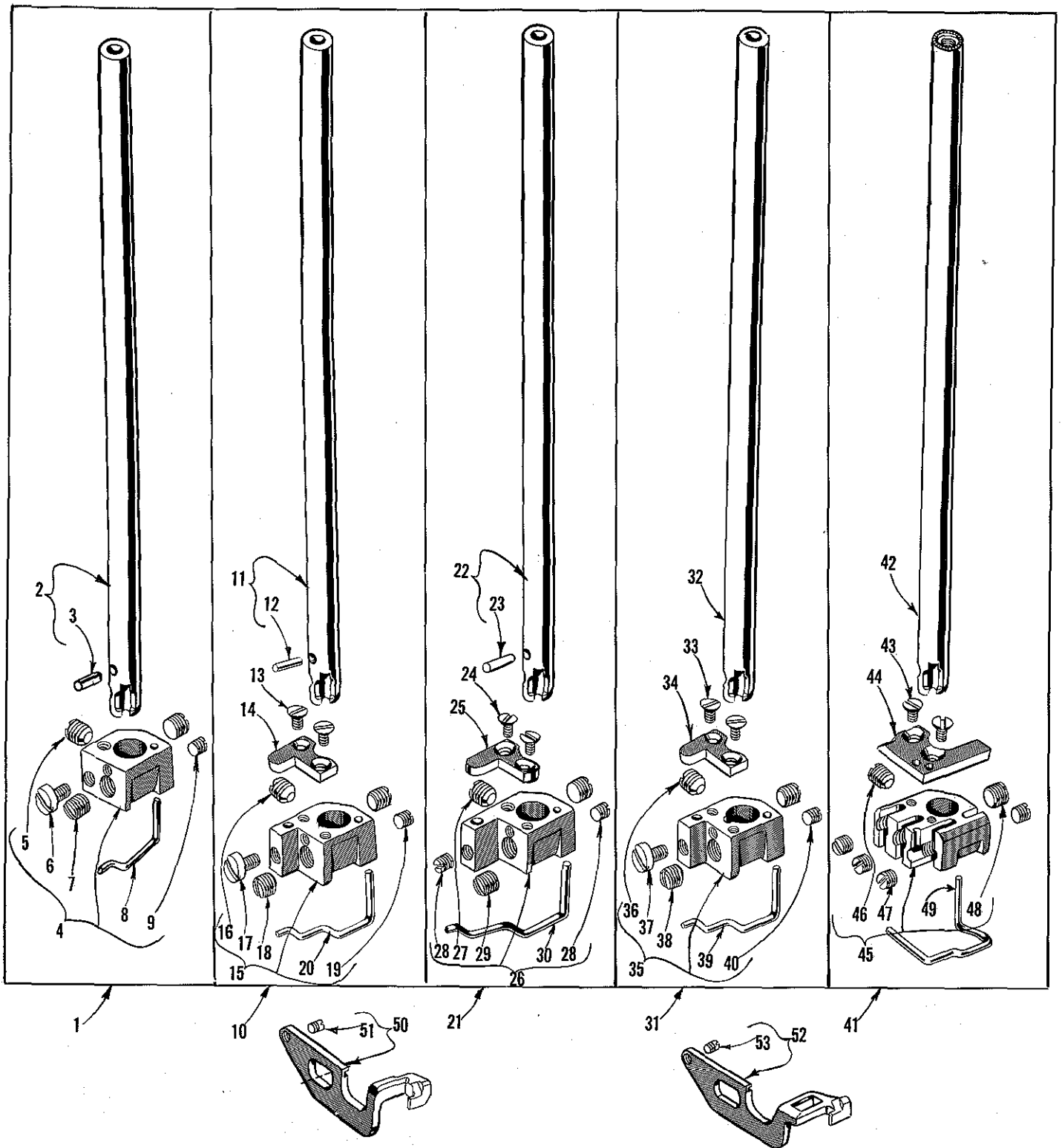

NEEDLE BARS, NEEDLE HOLDERS AND NEEDLE GUARDS

Ref. No.	Part No.	Description	Amt. Req.
1	29264 S-5-8	Needle Bar Assembly, for No. 5-8 gauge, Styles 52900 BF, BG, BH, BL, BM, BN, BR-----	1
2	52917-8	Needle Bar, marked "BE-8"-----	1
3	50 J-16	Needle Stop Pin-----	1
4	52918-5-8	Needle Clamp Collar, marked "AG"-----	1
5	89	Screw, spot-----	1
6	28	Screw, needle set-----	1
7	88 B	Screw, needle set-----	2
8	52842 G	Thread Guide Wire-----	1
9	28 C	Screw-----	1
10	29264 T-16-8	Needle Bar Assembly, for No. 16-8 gauge, Styles 52900 BG, BH, BL, BN, BR-----	1
11	52917-8	Needle Bar, marked "BE-8"-----	1
12	50 J-16	Needle Stop Pin-----	1
13	22716	Screw-----	2
14	52931	Needle Stop Plate-----	1
15	52918-16-8	Needle Clamp Collar, marked "R"-----	1
16	89	Screw, spot-----	1
17	28	Screw, needle set-----	1
18	88 B	Screw, needle set-----	2
19	28 C	Screw-----	1
20	52942 H	Thread Guide Wire-----	1
21	29264 U-24-8	Needle Bar Assembly, for No. 24-8 gauge, Style 52900 BG---	1
22	52917-8	Needle Bar, marked "BE-8"-----	1
23	50 J-16	Needle Stop Pin-----	1
24	22716	Screw-----	2
25	52931 A	Needle Stop Plate-----	1
26	52918-24-8	Needle Clamp Collar, marked "Y"-----	1
27	89	Screw, spot-----	1
28	28 C	Screw, needle set-----	2
29	88 B	Screw, needle set-----	2
30	52942 J	Thread Guide Wire-----	1
31	29264 U-12-12	Needle Bar Assembly, for No. 12-12 gauge, Styles 52900 BH, BL, BM, BN, BR-----	1
32	52917-12	Needle Bar, marked "BE-12"-----	1
33	22716	Screw-----	2
34	52931	Needle Stop Plate-----	1
35	52918-12-12	Needle Clamp Collar, marked "W"-----	1
36	89	Screw, spot-----	1
37	28	Screw, needle set-----	1
38	88 B	Screw, needle set-----	2
39	52942 H	Thread Guide Wire-----	1
40	28 C	Screw-----	1
41	29264 W-1-11-12	Needle Bar Assembly, for No. 1-11-12 gauge Style 52900 BP-----	1
42	52917 B-1-11-12	Needle Bar, marked "DU"-----	1
43	22716	Screw-----	2
44	52931 C	Needle Stop Plate-----	1
45	52918 A-1-11-12	Needle Clamp Collar, marked "AE"-----	1
46	89	Screw, spot-----	1
47	22743	Screw, needle set-----	4
48	88 B	Screw-----	1
49	52942 K	Thread Guide Wire-----	1
50	52925 G	Needle Guard, for Nos. 5-8, 24-8, 16-8 and 12-12 gauges Styles 52900 BF, BG, BH, BM, BN, BR-----	1
51	22801	Pivot Screw-----	1
52	52925 E	Needle Guard, for No. 1-11-12 gauge, Style 52900 BP----	1
53	22801	Pivot Screw-----	1

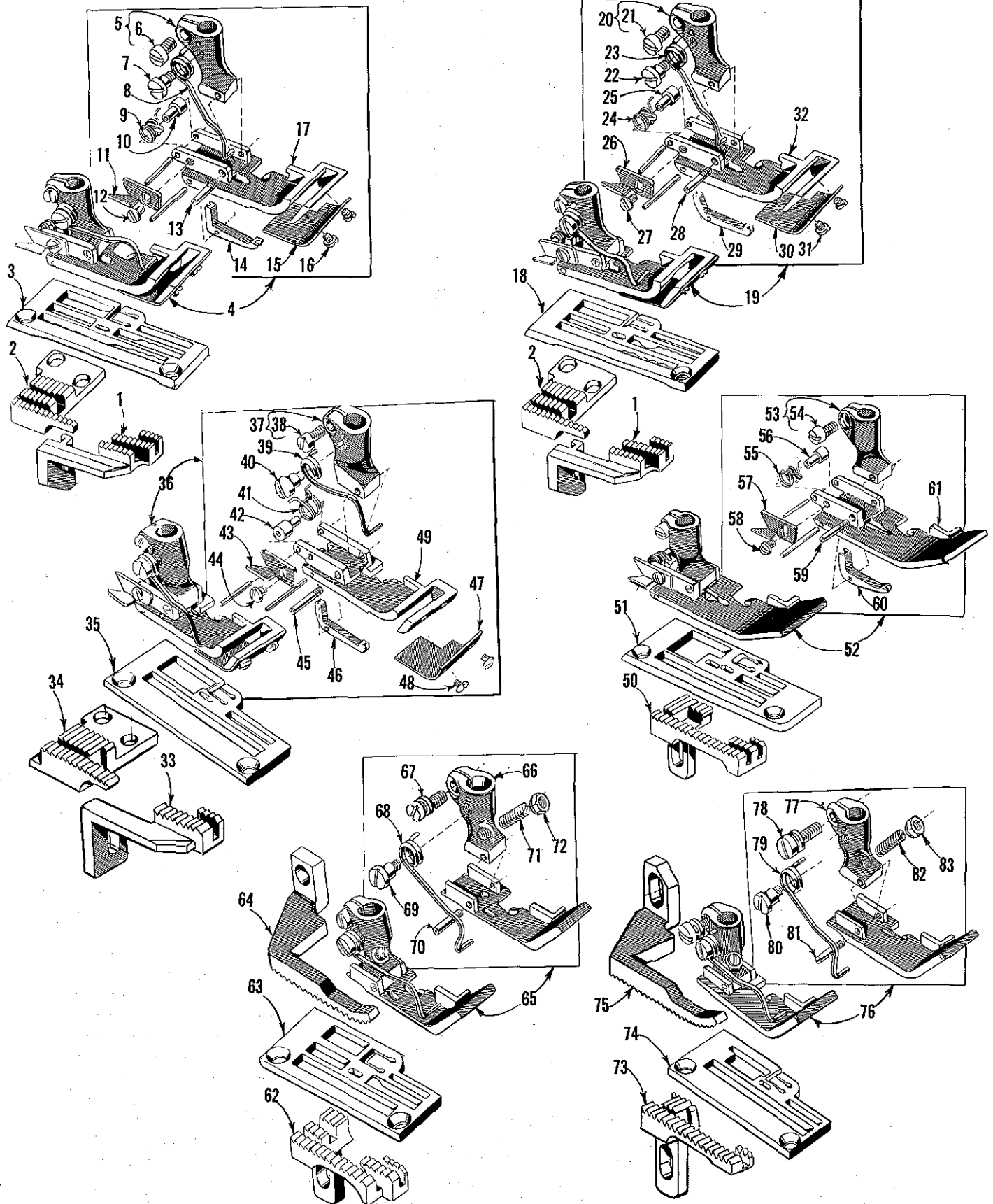

FEED DOGS, THROAT PLATES, PRESSER FEET

<u>Ref. No.</u>	<u>Part No.</u>	<u>Description</u>	<u>Amt. Req.</u>
1	52926 BL-12-12	Differential Feed Dog, for Nos. 12-12 and 16-8 gauges, Style 52900 BL -----	1
2	52905 BL-12-12	Main Feed Dog, for Nos. 12-12 and 16-8 gauges, Style 52900 BL -----	1
3	52928 BL-12-12	Throat Plate, for No. 12-12 gauge, Style 52900 BL -----	1
4	52920 BL-12-12	Presser Foot, for No. 12-12 gauge, Style 52900 BL -----	1
5	52930 HB	Presser Foot Shank -----	1
6	91	Screw -----	1
7	57 WD	Spring Screw -----	1
8	52830 G	Presser Foot Spring -----	1
9	52930 V	Needle Hole Section Spring-----	1
10	52930 AG	Spring Ferrule -----	1
11	52930 AC	Chain Cutter -----	1
12	604	Screw -----	1
13	22799 R	Hinge Screw-----	1
14	52930 J	Needle Hole Section -----	1
15	52930 AJ	Stripper Blade-----	1
16	91 A	Screw -----	2
17	52930 BL-12-12	Presser Foot Bottom-----	1
18	52928 BL-16-8	Throat Plate, for No. 16-8 gauge, Style 52900 BL -----	1
19	52920 BL-16-8	Presser Foot, for No. 16-8 gauge, Style 52900 BL -----	1
20	52930 HB	Presser Foot Shank -----	1
21	91	Screw -----	1
22	57 WD	Spring Screw -----	1
23	52830 G	Presser Foot Spring -----	1
24	52930 V	Needle Hole Section Spring-----	1
25	52930 AG	Spring Ferrule -----	1
26	52930 AC	Chain Cutter -----	1
27	604	Screw -----	1
28	22799 R	Hinge Screw-----	1
29	52930 J	Needle Hole Section -----	1
30	52930 AJ	Stripper Blade-----	1
31	91 A	Screw -----	2
32	52930 BL-16-8	Presser Foot Bottom-----	1
33	52926 BL-5-8	Differential Feed Dog, for No. 5-8 gauge, Style 52900 BL -----	1
34	52905 BL-5-8	Main Feed Dog, for No. 5-8 gauge, Style 52900 BL -----	1
35	52924 BL-5-8	Throat Plate, for No. 5-8 gauge, Style 52900 BL -----	1
36	52920 BL-5-8	Presser Foot, for No. 5-8 gauge, Style 52900 BL -----	1
37	52930 HB	Presser Foot Shank -----	1
38	91	Screw -----	1
39	52830 G	Presser Foot Spring -----	1
40	57 WD	Spring Screw -----	1
41	52930 V	Needle Hole Section Spring-----	1
42	52930 AG	Spring Ferrule -----	1
43	52930 AC	Chain Cutter -----	1
44	604	Screw -----	1
45	22799 R	Hinge Screw-----	1
46	52930 C	Needle Hole Section -----	1
47	52930 AK	Stripper Blade-----	1
48	91 A	Screw -----	2
49	52930 BL-5-8	Presser Foot Bottom-----	1
50 to 83		See following page	

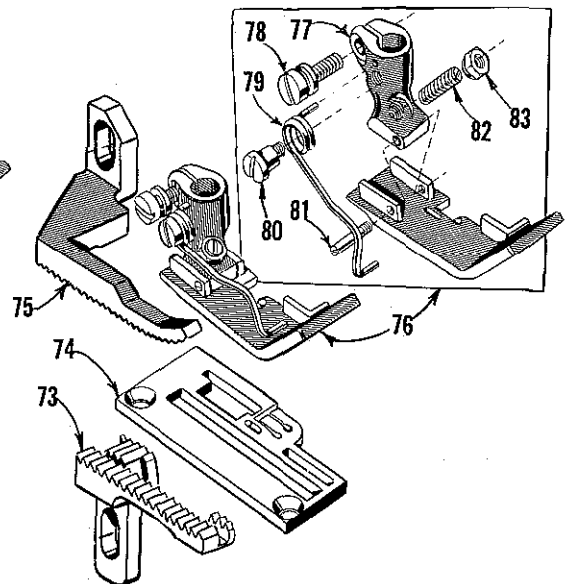
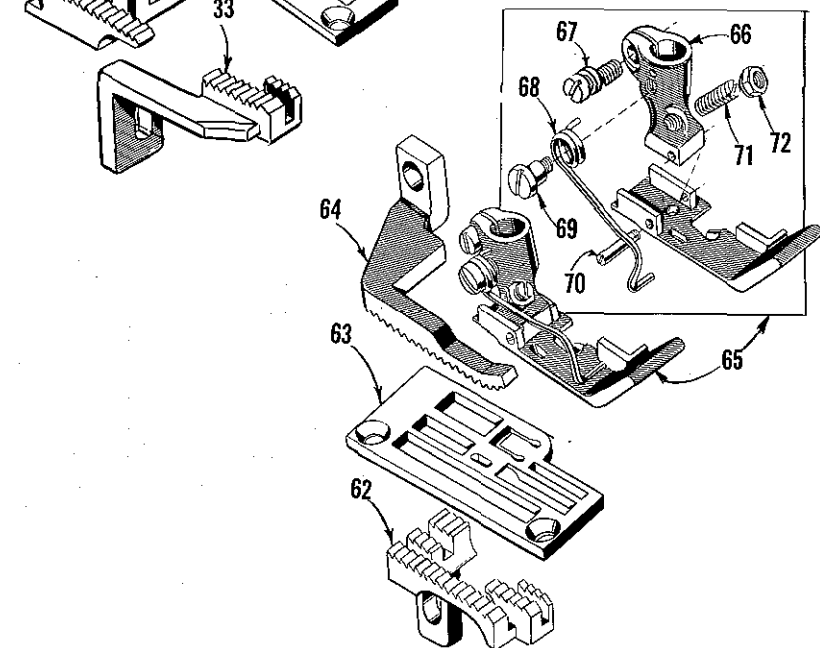
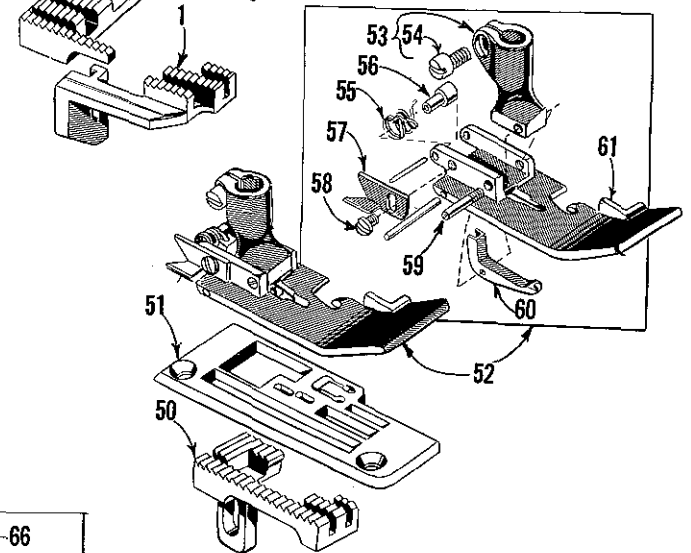
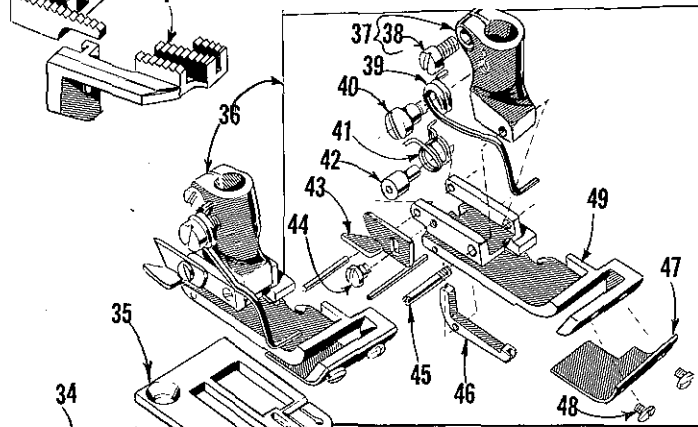
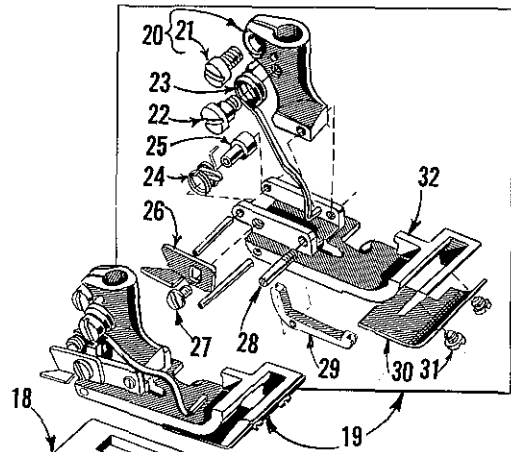
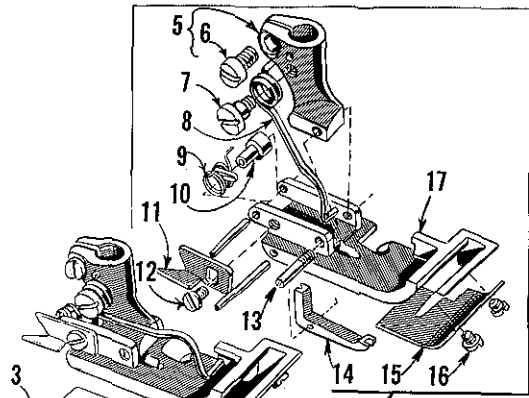

FEED DOGS, THROAT PLATES, PRESSER FEET

<u>Ref. No.</u>	<u>Part No.</u>	<u>Description</u>	<u>Amt. Req.</u>
1 to 49		See preceding page	
50	52905 BJ-1-11-12	Feed Dog, for No. 1-11-12 gauge, Style 52900 BP -----	1
51	52924 BJ-1-11-12	Throat Plate, for No. 1-11-12 gauge, Style 52900 BP -----	1
52	52920 BP-1-11-12	Presser Foot, for No. 1-11-12 gauge, Style 52900 BP -----	1
53	52930 H	Presser Foot Shank-----	1
54	91	Screw-----	1
55	52930 V	Needle Hole Section Spring -----	1
56	52930 AG	Spring Ferrule -----	1
57	52930 AC	Chain Cutter -----	1
58	604	Screw -----	1
59	22799 R	Hinge Screw -----	1
60	52930 AM	Needle Hole Section-----	1
61	52930 AL-1-11-12	Presser Foot Bottom -----	1
62	52905 BM-12-12	Feed Dog, for No. 12-12 gauge, Style 52900 BM-----	1
63	K67893	Throat Plate, for No. 12-12 gauge, Style 52900 BM-----	1
64	52926 BM-12-12	Upper Feed Dog, for No. 12-12 gauge, Style 52900 BM-----	1
65	K67719	Presser Foot, for No. 12-12 gauge, Style 52900 BM-----	1
66	K70976	Presser Foot Shank-----	1
67	22795	Screw -----	1
68	52830 G	Presser Foot Spring -----	1
69	57 WD	Spring Screw-----	1
70	22799 P	Hinge Screw -----	1
71	22840 A	Screw-----	1
72	51430 F	Nut -----	1
73	K68077	Feed Dog, for No. 5-8 gauge, Style 52900 BM -	1
74	K68076	Throat Plate, for No. 5-8 gauge, Style 52900 BM-----	1
75	K68413	Upper Feed Dog, for No. 5-8 gauge, Style 52900 BM-----	1
76	K67615	Presser Foot, for No. 5-8 gauge, Style 52900 BM-----	1
77	K70976	Presser Foot Shank-----	1
78	22795	Screw -----	1
79	52830 G	Presser Foot Spring -----	1
80	57 WD	Spring Screw-----	1
81	22799 P	Hinge Pin-----	1
82	22840 A	Screw -----	1
83	51430 F	Nut -----	1

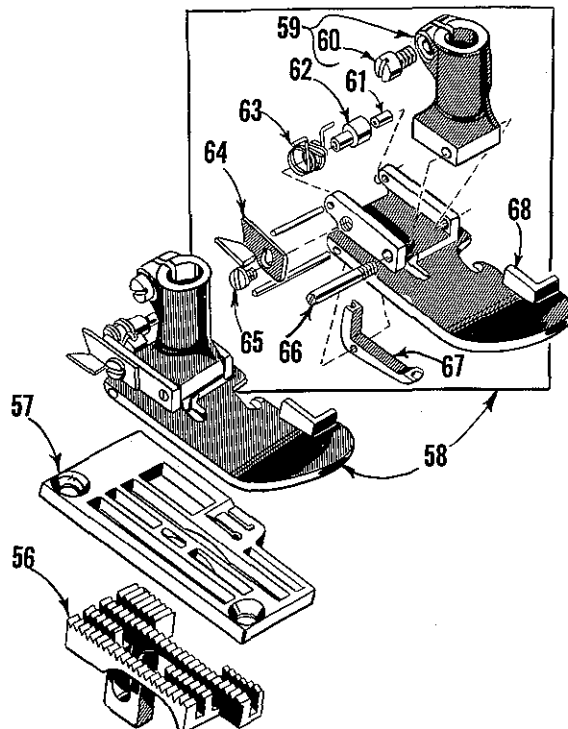
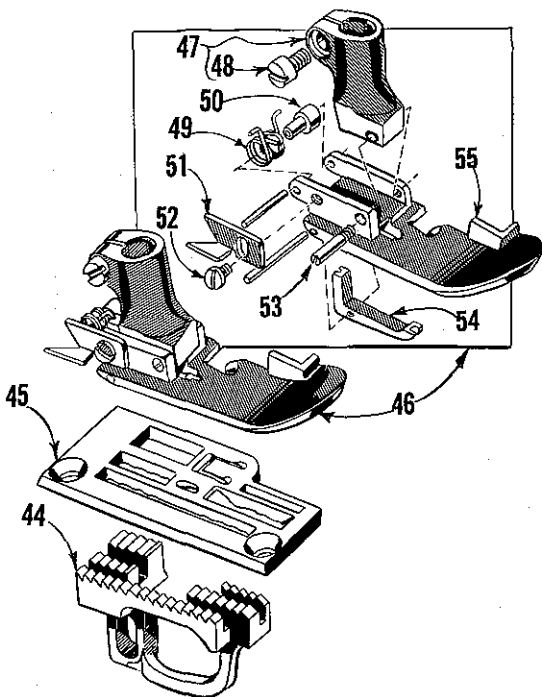
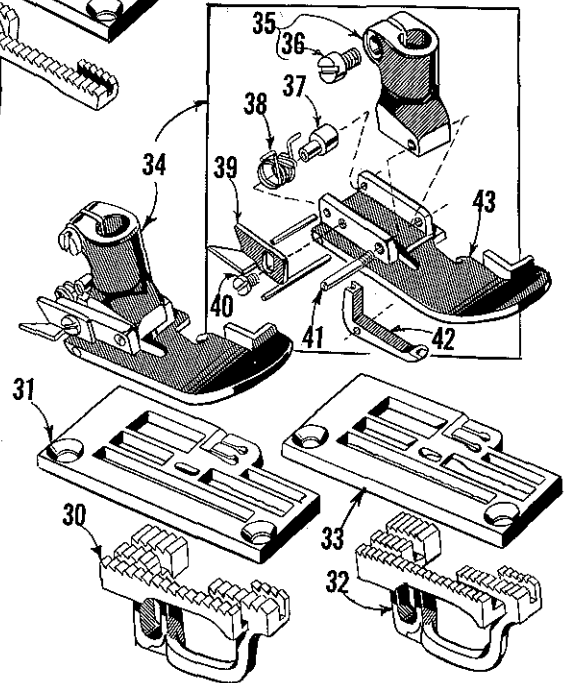
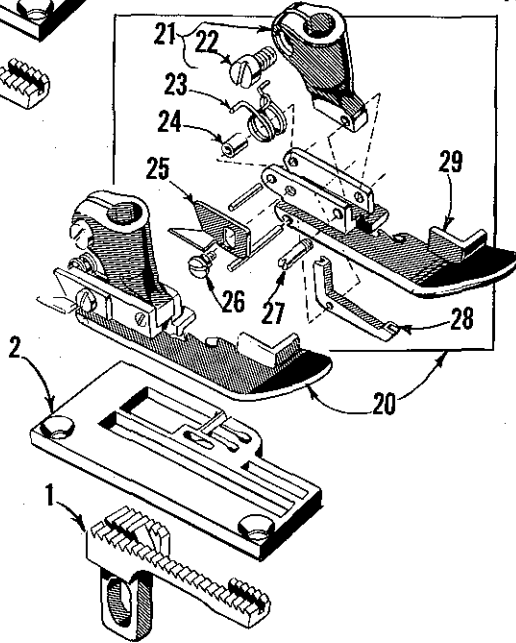
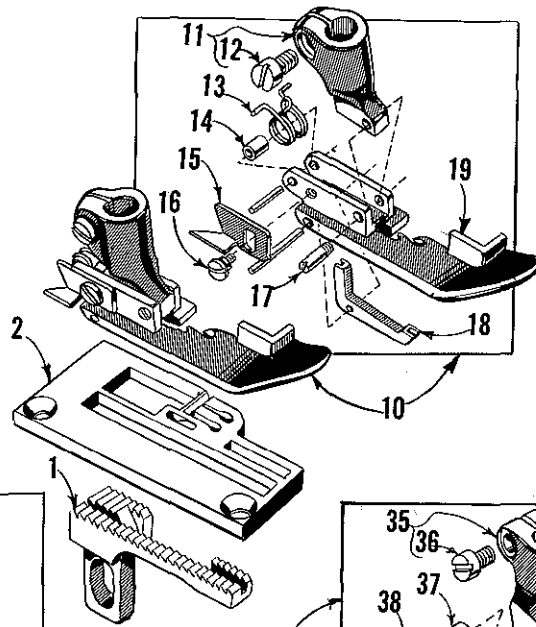
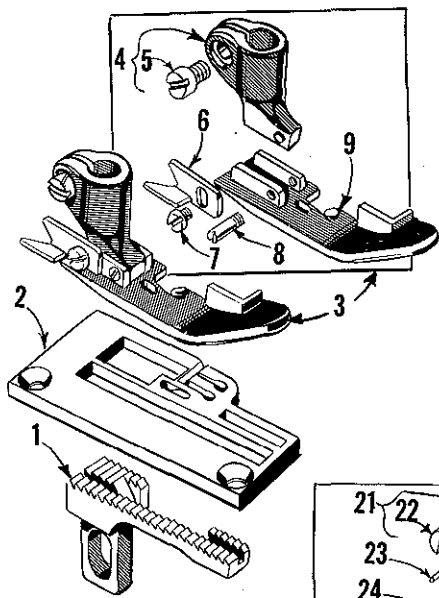

FEED DOGS, THROAT PLATES, PRESSER FEET

Ref. No.	Part No.	Description	Amt. Req.
1	52905 BH-5-8	Feed Dog, 16 teeth per inch, for No. 5-8 gauge, Styles 52900 BF, BG, BH, BN-----	1
-	52926 BR-5-8	Feed Dog, 22 teeth per inch, for No. 5-8 gauge, Style 52900 BR-----	1
2	52924 BH-5-8	Throat Plate, .060 inch needle hole, for 5-8 gauge, Styles 52900 BF, BG, BH, BN-----	1
-	52928 BR-5-8	Throat Plate, .050 inch needle hole, for No. 5-8 gauge, Style 52900 BR-----	1
3	52920 F-5-8	Presser Foot, for No. 5-8 gauge, Style 52900 BF-----	1
4	52930	Presser Foot Shank-----	1
5	91	Screw-----	1
6	52930 AC	Chain Cutter-----	1
7	91 A	Screw-----	1
8	22799 F	Hinge Screw-----	1
9	52930 Y	Presser Foot Bottom-----	1
10	52920 G-5-8	Presser Foot, for No. 5-8 gauge, Styles 52900 BH, BN, BR-----	1
11	52930	Presser Foot Shank-----	1
12	91	Screw-----	1
13	52930 V	Needle Hole Section Spring-----	1
14	52930 W	Bearing Sleeve-----	1
15	52930 AC	Chain Cutter-----	1
16	604	Screw-----	1
17	22799 F	Hinge Screw-----	1
18	52930 C	Needle Hole Section-----	1
19	52930 Z	Presser Foot Bottom-----	1
20	52920 BG-5-8	Presser Foot, for No. 5-8 gauge, Style 52900 BG-----	1
21	52930	Presser Foot Shank-----	1
22	91	Screw-----	1
23	52930 V	Needle Hole Section Spring-----	1
24	52930 W	Bearing Sleeve-----	1
25	52930 AC	Chain Cutter-----	1
26	604	Screw-----	1
27	22799 F	Hinge Screw-----	1
28	52930 C	Needle Hole Section-----	1
29	52930 AR	Presser Foot Bottom-----	1
30	52926 BH-16-8	Feed Dog, for No. 16-8 gauge, Styles 52900 BH, BN-----	1
31	52924 D-16-8	Throat Plate, for No. 16-8 gauge, Styles 52900 BH, BN-----	1
-	52928 BR-16-8	Throat Plate, for No. 16-8 gauge, Style 52900 BR-----	1
32	52926 BB-16-8	Feed Dog, for No. 16-8 gauge, Style 52900 BG-----	1
-	52926 BR-16-8	Feed Dog, for No. 16-8 gauge, Style 52900 BR-----	1
33	52928 A-16-8	Throat Plate, for No. 16-8 gauge, Style 52900 BG-----	1
*34	52920 G-16-8	Presser Foot, for No. 16-8 gauge, Styles 52900 BG, BH, BN, BR-----	1
35	52930 HA	Presser Foot Shank-----	1
36	91	Screw-----	1
37	52930 AG	Spring Ferrule-----	1
38	52930 V	Needle Hole Section Spring-----	1
39	52930 AC	Chain Cutter-----	1
40	604	Screw-----	1
41	22799 R	Hinge Screw-----	1
42	52930 J	Needle Hole Section-----	1
43	52930 AA	Presser Foot Bottom-----	1
44	52926 C-16-8	Feed Dog, 12 teeth per inch, for No. 12-12 gauge, Styles 52900 BH, BN-----	1
-	52926 BR-12-12	Feed Dog, 22 teeth per inch, for No. 12-12 gauge, Style 52900 BR-----	1
45	52924 C-12-12	Throat Plate, .070 inch needle hole, for No. 12-12 gauge, Styles 52900 BH, BN, BR-----	1
46	52920 H-12-12	Presser Foot, for No. 12-12 gauge, Styles 52900 BH, BN, BR-----	1
47	52930 H	Presser Foot Shank-----	1
48	91	Screw-----	1
49	52930 V	Needle Hole Section Spring-----	1
50	52930 AG	Spring Ferrule-----	1
51	52930 AC	Chain Cutter-----	1
52	604	Screw-----	1
53	22799 R	Hinge Screw-----	1
54	52930 J	Needle Hole Section-----	1
55	52930 X	Presser Foot Bottom-----	1
56	52926 A-24-8	Feed Dog, for No. 24-8 gauge, Style 52900 BG-----	1
57	52928 A-24-8	Throat Plate, for No. 24-8 gauge, Style 52900 BG-----	1
58	52920 G-24-8	Presser Foot, for No. 24-8 gauge, Style 52900 BG-----	1
59	52930 AD	Presser Foot Shank-----	1
60	91	Screw-----	1
61	52930 W	Bearing Sleeve-----	1
62	52930 AG	Spring Ferrule-----	1
63	52930 V	Needle Hole Section Spring-----	1
64	52930 AC	Chain Cutter-----	1
65	604	Screw-----	1
66	22799 E	Hinge Screw-----	1
67	52930 J	Needle Hole Section-----	1
68	52930 AE	Presser Foot Bottom-----	1

* NOTE: Tilt adjusting screw No. 22840 A, and locking nut No. 51430 F, are components of presser foot 52920 G-16-8, but are not shown on picture plate.

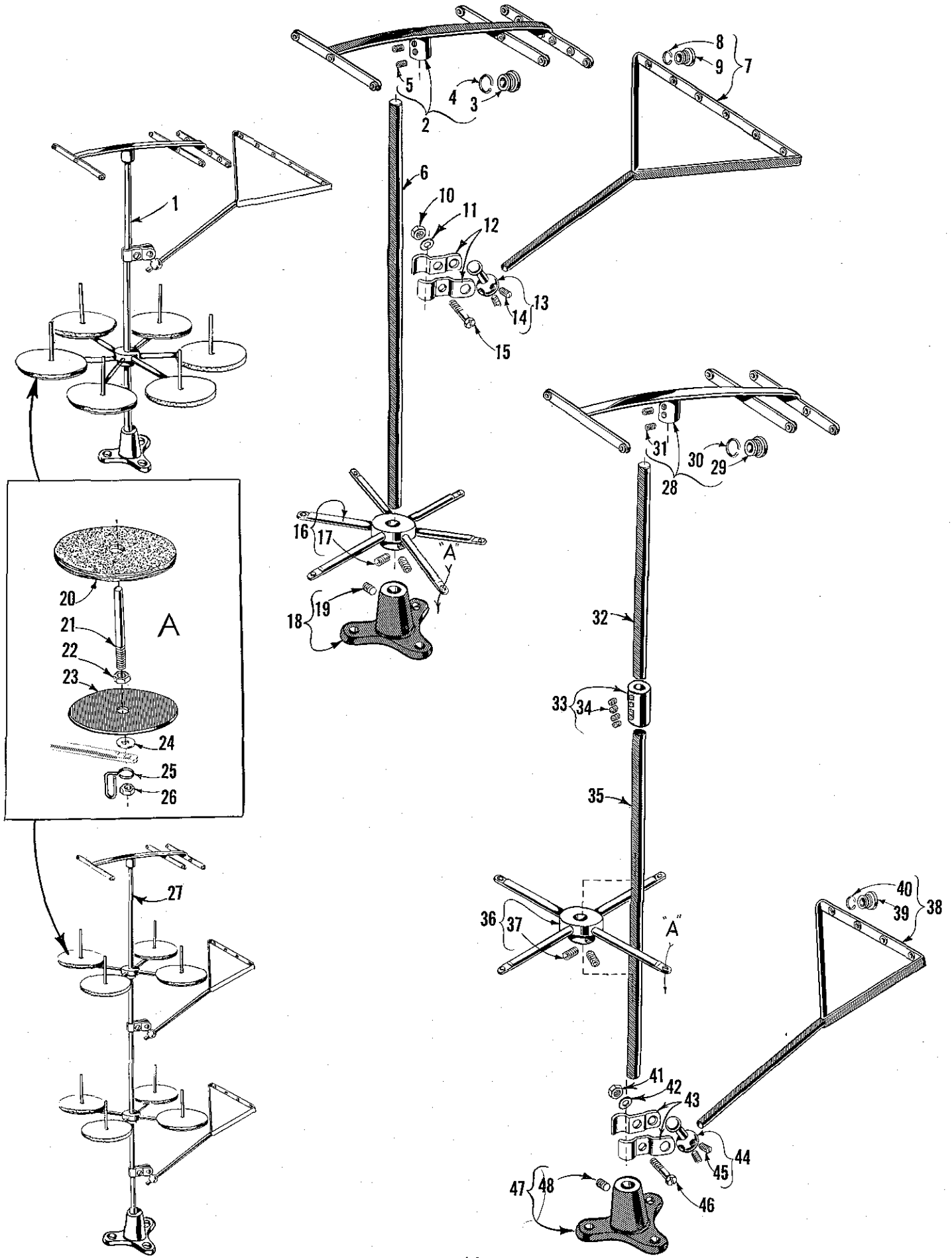

THREAD STAND AND ACCESSORIES

<u>Ref. No.</u>	<u>Part No.</u>	<u>Description</u>	<u>Amt. Req.</u>
1	21101 H-6	Thread Stand, complete, for Styles 52900 BF, BG, BH, BL, BM, BN-----	1
2	21114 H-6	Eyelet Support -----	1
3	21114 L	Eyelet-----	12
4	21114 M	Eyelet Locking Ring -----	12
5	22651 CD-4	Screw -----	2
6	21104 B-24	Thread Stand Rod-----	1
7	21114 S-6	Lead Eyelet-----	1
8	21114 M	Eyelet Locking Ring -----	6
9	21114 L	Eyelet-----	6
10	21104 H	Nut -----	1
11	652-16	Washer-----	1
12	21114 U	Lead Eyelet Ball Split Socket -----	2
13	21114 T	Lead Eyelet Socket Ball -----	1
14	22651 CD-4	Screw -----	2
15	22810	Screw -----	1
16	21114 D-6	Spool Seat Support -----	1
17	22651 CD-5	Screw -----	2
18	21114 A	Thread Stand Base-----	1
19	22651 CD-4	Screw -----	1
20	21104 V	Felt Pad, for 21101 H-6-----	6
	21104 V	Felt Pad, for 21101 P-8-----	8
21	21114 W	Spool Pin, for 21101 H-6-----	6
	21114 W	Spool Pin, for 21101 P-8-----	8
22	258 A	Nut, for 21101 H-6 -----	6
	258 A	Nut, for 21101 P-8 -----	8
23	21114	Spool Seat Disc, for 21101 H-6-----	6
	21114	Spool Seat Disc, for 21101 P-8-----	8
24	652-16	Washer, for 21101 H-6-----	6
	652-16	Washer, for 21101 P-8-----	8
25	21114 AF	Eyelet, for 21101 P-8 -----	4
26	258 A	Nut, for 21101 H-6 -----	6
	258 A	Nut, for 21101 P-8 -----	8
27	21101 P-8	Thread Stand, complete, for Style 52900 BP-----	1
28	21114 H-4	Eyelet Support -----	1
29	21114 L	Eyelet-----	8
30	21114 M	Eyelet Locking Ring -----	8
31	22651 CD-4	Screw -----	2
32	21104 B-11	Thread Stand Rod, upper -----	1
33	21127	Coupling-----	1
34	22651 CD-3	Screw -----	4
35	21104 B-24	Thread Stand Rod, lower -----	1
36	21114 D-4	Spool Seat Support -----	2
37	22651 CD-5	Screw -----	2
38	21114 S-4	Lead Eyelet-----	2
39	21114 L	Eyelet-----	4
40	21114 M	Eyelet Locking Ring -----	4
41	21104 H	Nut -----	2
42	652-16	Washer-----	2
43	21114 U	Lead Eyelet Ball Split Socket -----	4
44	21114 T	Lead Eyelet Socket Ball -----	2
45	22651 CD-4	Screw -----	2
46	22810	Screw -----	2
47	21114 A	Thread Stand Base-----	1
48	22651 CD-4	Screw -----	1

ACCESSORIES

- * 660-240 Thread Tweezers
- * 421 D-28 Treadle Chain, for presser foot
- * 421 D-38 Treadle Chain, for Style 52900 BL only
- * 21201 Screw Driver, 9/64 inch round blade, length over-all 7 5/8 inches
- * 21388 Wrench, single end, 3/8 inch opening
- * 21388 W Wrench, double end, curved, 9/32 inch opening
- * 29402 Treadle, for Style 52900 BL only
- * 51493 BC Lifter Link, for presser foot

* The tools and accessories are not illustrated but furnished with all machines except where indicated.

NUMERICAL INDEX OF PARTS

<u>Part No.</u>	<u>Page No.</u>	<u>Part No.</u>	<u>Page No.</u>	<u>Part No.</u>	<u>Page No.</u>	<u>Part No.</u>	<u>Page No.</u>
WO3	17	666-81	29	22559 A	17	22894 W	33
8	25, 27, 29	666-82	29	22559 G	17	22894 X	17
18	17, 19, 21	666-99	15	22560 B	11, 17, 23,	29066 R	17
PI18	29	666-111	15		31	29126 CR	17
20	11, 21, 23,	666-114	15	22562	33	29192 G	21
	27, 29	666-118	15	22562 A	17	29192 S	21
HA20 A	17	666-138	31	22564	17	29192 U	21
CL21	19, 23	666-149	23, 27, 29	22565 C	23, 33	29264 S	35
25 CC	25	666-170	31	22568	13	29264 T	35
28	11, 35	666-179	15	22569 B	15, 17	29264 U	35
28-182 Blk.	15	666-201	15	22571 A	15	29264 W	35
28 C	35	666-209	15	22571 B	15	29348 AF	17
50-216 Blk.	11	666-214	15	22572 A	11	29476 AR	29
50-458 Blk.	21	668-25	19, 33	22580	19, 23, 27,	29476 BJ	29
50-648 Blk.	15	668-28	19, 33		29	29476 DR	27
50-789 Blk.	11	719	11, 25	22585 A	13	29476 DX	23, 27
50 J	35	907	23	22585 B	27, 31	29476 GM	29
57 WD	37, 39	1740	21	22585 R	13	29476 HL	17
73	21	6042 A	19, 31	22586 R	17	29476 HW	17
73 A	17, 21	8372 A	25	22587	17	29476 LE	17
77	17, 23, 25,	9937	25	22587 H	17	35178 D	15
	27, 31	12934 A	19, 25	22588 A	13	35582 B	11
77 A	33	14649	31	22593	23	35731 A	11
80	13	15037 A	19	22596	19, 33	35766	13
82	23, 27, 29	15438 B	11	22597	11	39135	25
87	13	15438 C	11	22598 C	33	39158 U	11
88	21, 31	15438 D	11	22645 H	15	39237	23
88 B	29, 35	15455	15	22651 CD	43	39237 D	23
89	35	15465 F	21	22706 A	15	39237 G	23
90	11, 15, 19,	21101 H	43	22711	11	39552 C	33
	23, 29, 31	21101 P	43	22716	35	39582 L	11
91	37, 39, 41	21104 B	43	22729 A	15	39595	15
91 A	37, 41	21104 H	43	22729 B	15	41076 D	17
93	11	21104 V	43	22729 D	17	41355 U	21
95	11, 17, 19	21114	43	22730	11	41394 A	13
HA95	29	21114 A	43	22733 B	13	43139 A	25
96	21, 23, 27,	21114 D	43	22738 D	19	43266	19, 33
	29	21114 H	43	22743	17, 35	51034 A	29
97	19	21114 L	43	22747	23	51054	23, 27, 29
98	21, 25, 27,	21114 M	43	22758 B	25	51134 A	27
	31	21114 S	43	22758 C	35	51134 C	27, 31
98 A	11	21114 T	43	22768	11, 17, 21,	51134 J	27, 31
109	19, 33	21114 U	43		23	51134 N	29
129	19	21114 W	43	22795	39	51134 P	27
158 A	11	21114 AF	43	22799 E	41	51134 R	27
158 B	11	21210 B	29	22799 F	41	51134 T	31
166	27	21212	15	22799 M	11	51134 V	31
258	15, 19, 31	BB 21375 AH	11	22799 P	39	51134 HA	31
258 A	15, 21, 27,	21657 E	11	22799 R	37, 39, 41	51135 P	31
	43	21657 W	33	22801	23, 27, 29,	51135 R	31
269	19, 21, 23,	21657 X	15		35	51144	21
	27, 29	21657 Y	33	22810	43	51147	19
294	11, 15	21657 AM	33	22811 B	19		
402	33	22513	11	22823 A	15	51216 G	17
482	25	22516	25	22823 B	15	51216 M	17
531	15, 33	22517	19	22829	21	51216 N	17, 21, 31
538	27, 31	22517 C	11	22834	27, 31	51216 P	17
539	11	22519 C	25, 27	22839	13	51225 W	23, 27, 31
604	37, 39, 41	22519 H	21	22839 A	13	51235	27
643-127 Blk.	15	22519 J	23	22840 A	39	51235 A	27
643-263 Blk.	15	22524	13	22848	11, 13, 25	51235 G	25, 27
652-16	43	22526	19	22852	31	51236 A	23, 27, 29
652 C-9	17	22528	11, 27, 29,	22857 B	19	51236 B	23
660-136	15		31	22863	27, 31	51236 D	23, 27, 29
660-169	23, 27, 29	22537	33	22868 A	23	51236 E	23, 27, 29
660-202	17, 19, 33	22539 D	11	22872	19	51236 F	23, 27, 29
660-207	33	22539 H	15	22882 A	21	51236 G	23, 27, 29
660-212	17	22541 B	11	22889 A	11	51240 D	19
660-215	17	22542	11	22894 C	29	51240 E	21
660-244	17	22548	11, 13	22894 D	23, 27, 29	51242 M	21
660-246	17	22557 B	33	22894 G	17	51243 C	17
660-310	21			22894 P	25	51244	21
660-614	17					51244 B	21
666-65	15						

NOTE: Only the basic part numbers are shown in the index. For various gauges, capacities, etc. available, refer to the listings on pages indicated.

NUMERICAL INDEX OF PARTS

<u>Part No.</u>	<u>Page No.</u>	<u>Part No.</u>	<u>Page No.</u>	<u>Part No.</u>	<u>Page No.</u>	<u>Part No.</u>	<u>Page No.</u>
51244 L	21	52882 P	11	52926 BM	39	52973 Q	19
51244 N	21	52882 R	11	52926 BR	41	52973 S	19
51246	21	52882 S	11	52928 A	41	52973 T	19
51250 D	17	52882 U	13	52928 BL	37	52973 U	19
51250 F	17	52882 W	11	52928 BR	41	52973 V	19
51254 C	15	52882 Z	11	52930	41	52973 W	19
51254 K	17	52882 AA	11	52930 C	37, 41	52973 X	19
51256 C	33	52882 AC	11	52930 H	39, 41	52973 Z	19
51257 M	33	52882 AD	11	52930 J	37, 41	52978 H	11
51280 J	13	52882 AF	13	52930 V	37, 39, 41	52978 T	11
51283 H	33	52883 R	15	52930 W	41	52978 U	11
51290 T	15	52883 S	33	52930 X	41	52978 W	11
51292	19	52885 L	11	52930 Y	41	52980	13
51292 A	19, 33	52888 B	33	52930 Z	41	52980 A	13
51292 C	19, 33	52889 A	33	52930 AA	41	52980 C	13
51292 D	19, 33	52890 C	15	52930 AC	37, 39, 41	52982 D	13
51292 F	19, 33	52891 B	15	52930 AD	41	52982 E	13
51292 G	33	52894 K	15	52930 AE	41	52982 F	13
51294 K	15	52894 AB	15	52930 AG	37, 39, 41	52985	11
51294 U	15	52894 AD	15	52930 AJ	37	52985 A	11
51294 Y	15	52894 AE	15	52930 AK	37	52992 A	33
51295 B	15	52894 AK	15	52930 AL	39	52994 U	15
51380 A	13	52894 AN	11	52930 AM	39	52994 V	15
51382 A	13	52901 J	13	52930 AR	41	52994 AA	15
51430 F	39	52901 K	13	52930 BL	37	52994 AC	15
51435	25	52901 L	13	52930 HA	41	52994 AD	15
51435 B	25	52901 M	13	52930 HB	37	52994 AG	15
51491 C	33	52902 B	13	52931	35	53636 C	19
51493 D	15	52902 C	13	52931 A	35	53688	33
51493 E	15	52904	11	52931 C	35	53783 A	33
51493 AG	15	52904 A	11	52931 G	11	53783 L	33
51493 AH	15	52905 BH	41	52934	31	53783 M	33
51493 AZ	15	52905 BJ	39	52934 A	29	53783 N	33
51493 BB	15	52905 BL	37	52934 B	31	54158	17
51493 BG	15	52905 BM	39	52934 C	31	54158 A	17
51493 BH	15	52908 D	21	52934 D	29	55235 D	19, 31
51493 BJ	15	52908 F	21	52935	31	55235 E	19, 31
51493 BK	11	52909 A	21	52942 A	17	55244 G	21
51493 BP	17	52909 B	21	52942 H	35	56315 A	17
51493 BQ	15	52909 D	21	52942 J	35	56334 E	27
51745	21	52909 E	21	52942 K	35	56341 E	21
51892	33	52910	21	52942 P	21	56341 F	21
52336 A	17	52913	21	52942 R	21	56341 G	21
52794 G	15	52913 A	21	52942 W	15	56341 M	21
52808 E	21	52913 B	21	52942 X	15	56343 D	17
52822 B	23	52916	17	52942 Y	11	56350 D	17
52830 G	37, 39	52917	35	52943 L	17	56350 E	17
52834	23	52917 B	35	52944 A	11	56350 F	17
52834 H	23	52918	35	52944 C	17	56354 D	17
52835	25	52918 A	35	52944 D	11	56382 AC	11
52835 G	25	52920 F	41	52944 S	11	56390 E	15
52835 K	25	52920 G	41	52944 U	15	56958	17
52835 N	25	52920 H	41	52945 L	33	56958 A	17
52835 Q	25	52920 BG	41	52945 M	33	57770	11
52835 S	23	52920 BL	37	52947 A	17	57836 F	25
52835 U	25	52920 BP	39	52949 A	13	57885	11
52835 V	23	52921 B	17	52950 A	13	57885 B	11
52836	25	52922 C	27	52950 B	13	57902	13
52836 C	25	52922 G	29	52950 H	13	57978	11
52836 H	25	52923 C	23, 27, 29	52951	17	57978 A	11
52836 P	15	52924 C	41	52951 A	17	60077 K	19
52836 R	15	52924 D	41	52951 B	17	61267 G	25
52841 A	21	52924 BH	41	52951 C	17	K67615	39
52842 A	17	52924 BJ	39	52952 B	17	K67719	39
52842 G	35	52924 BL	37	52952 C	19	K67893	39
52846 A	33	52925 C	23	52953 A	23	K68042	33
52847	33	52925 D	23	52954 B	15	K68076	39
52848 B	19	52925 E	35	52957	11	K68077	39
52848 C	19	52925 G	35	52957 A	11	K68413	39
52849	19	52926 A	41	52958	11	K68719	29
52849 B	19	52926 C	41	52958 G	11	K70976	39
52849 C	19	52926 BB	41	52970 E	19	80557	33
52855 A	19	52926 BH	41	52973 K	19	92127	31
52855 G	19	52926 BL	37	52973 L	19		

NOTE: Only the basic part numbers are shown in the index. For various gauges, capacities, etc. available, refer to the listing on pages indicated.

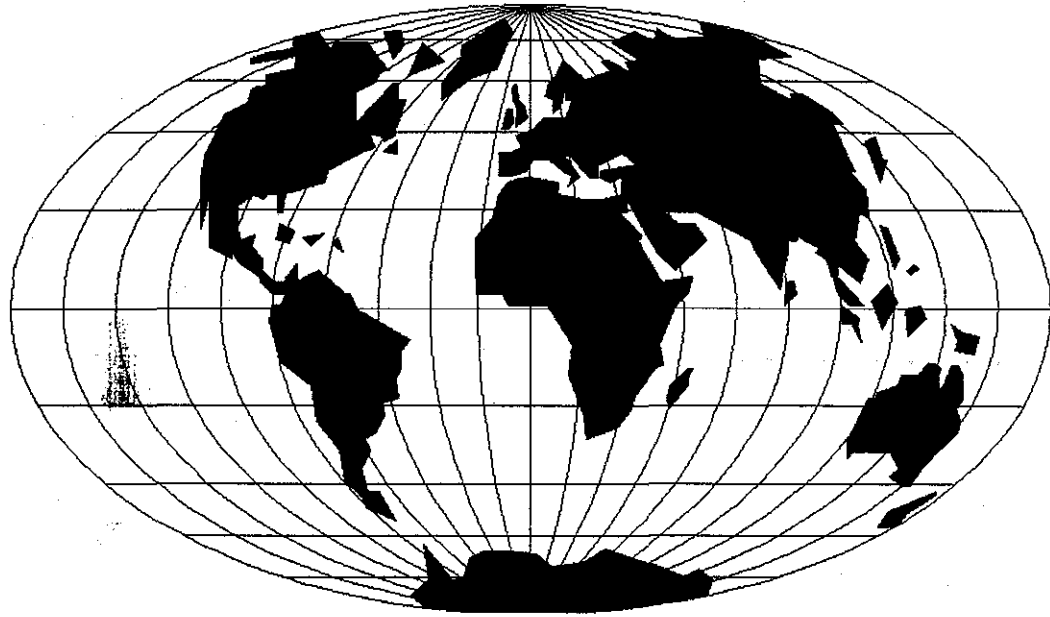

WORLDWIDE SALES AND SERVICE

Union Special Corporation maintains sales and service facilities throughout the world. These offices will aid you in the selection of the right sewing equipment for your particular operation. Union Special Corporation representatives and service technicians are factory trained and are able to serve your needs promptly and efficiently. Whatever your location, there is a qualified representative to serve you.

Corporate Office: One Union Special Plaza
Huntley, IL 60142
Phone: 708•669•5101
Fax: 708•669•1096

European Distribution Center: Union Special GmbH
Raiffeisenstrasse 3
D-71696 Möglingen, Germany
Tel: 49•07141•247•0
Fax: 49•7141•247•100

Brussels, Belgium
Charlotte, N.C.
Commerce, CA
El Paso, TX
Hong Kong, China
Huntley, IL
Leicester, England
Lille, France
Miami, FL
Milan, Italy
Mission, TX
Möglingen, Germany
Montreal, Quebec
Osaka, Japan

Other Representatives throughout
all parts of the world.



Union Special
INDUSTRIAL SEWING EQUIPMENT