

FILE

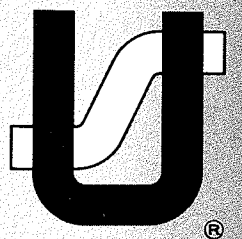

FINEST QUALITY

Union Special[®]
LEWIS[®] • COLUMBIA[®]

**INDUSTRIAL
SEWING
MACHINES**

**PROPERTY OF
DEVELOPMENT/CATALOG DEPT.**

Please return to the Catalog Dept.

OCT 02 1992

Date received to file: _____

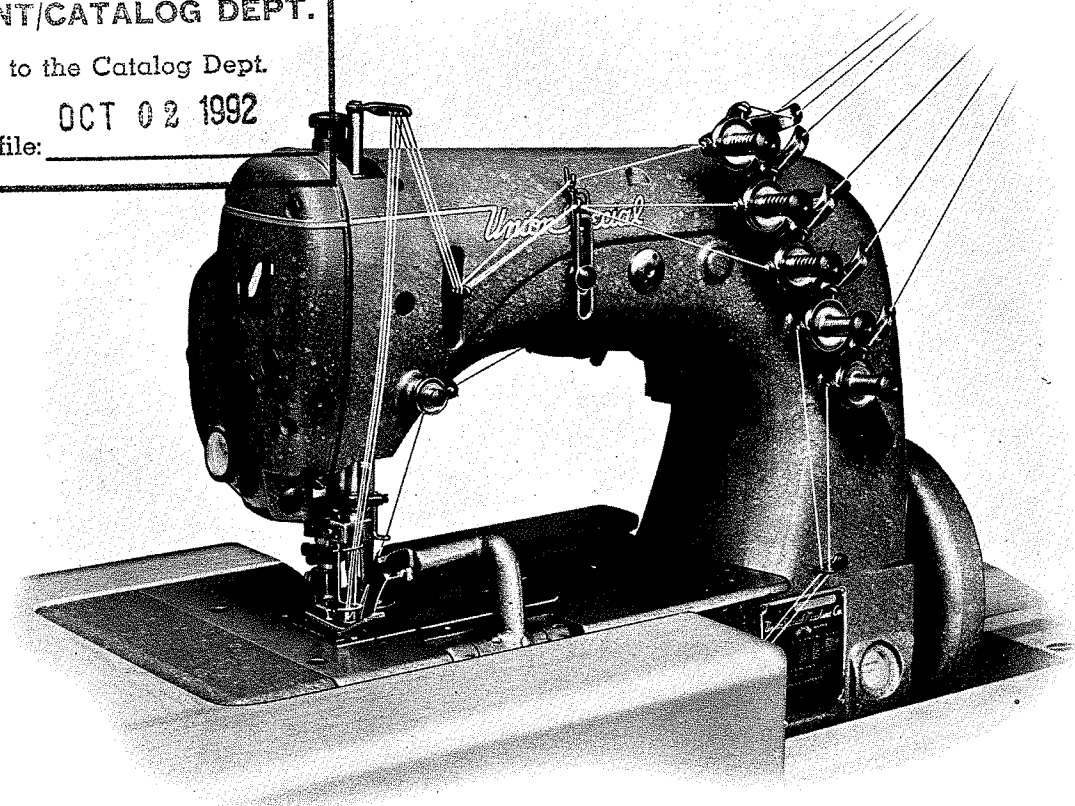

**STYLES
52900BA
52900BB
52900BC
52900BE
52900BJ**

**CATALOG
No.
97P**

CLASS 52900

STREAMLINED

HIGH SPEED

SAFETY STITCH MACHINES

REAR DISPOSAL OF TRIMMINGS

UNION SPECIAL CORPORATION

CHICAGO

Price \$2.00

Union Special Wants to Help You Cut Sewing Machine Maintenance Costs

Union Special is offering two practical systems to help pinpoint and reduce your sewing machine maintenance costs: a record keeping system to help spot machines requiring abnormally high maintenance, and a parts inventory system to speed routine repairs.

Machine Maintenance Records

Repair-prone machines or inexperienced operators can eat up your maintenance dollars in short order. To help spot these problems, Union Special suggests two variations of a simple maintenance record keeping system using cards provided by Union Special.

The first system utilizes a "Machine Maintenance Record" card (Form 237) for each sewing machine in a plant. When a repair is required, the card is pulled from the file and the repair date, parts used, and their cost are entered in the spaces provided and the card is refilled.

MACHINE MAINTENANCE RECORD					
MAKER'S NAME		STYLE	TYPE NEEDLE	SERIAL NO.	DATE PURCH.
DATE	SYMBOL PART USED	COST	DATE	SYMBOL PART USED	COST

FORM 237—
Machine Maintenance
Record card

UNION SPECIAL MACHINE CO. FORM NO. 237 PRINTED IN U.S.A.

The second system is normally used when more detailed information on repair costs is desired. Two record cards are used: a "Repair Request Card" (Form 234), and a "Machine Repair Record" (Form 233). When a machine requires service, the

MACHINE REPAIR RECORD CARD							INV. SYMBOL
MAKER'S NAME		MAKER'S SYMBOL	NEEDLES EMPLOYED	SERIAL NUMBER	DATE OF PURCHASE		
DATE	MECH'S NO.	LABOR COST	PARTS COST	TOTAL COST	SERVICE DAYS		

REPAIR REQUEST CARD

DATE: _____

INVENTORY SYMBOL: _____

MAKER'S NAME: _____

MACH. SERIAL NO.: _____

OPERATOR'S NO.: _____

PARTS USED

PCB.	PART NUMBER	COST

TIME STARTED: _____

TIME COMPLETED: _____

MECHANIC'S NO.: _____ HRS.: _____

UNION SPECIAL MACHINE CO. FORM NO. 234 PRINTED IN U.S.A.

FORM 233—
Machine Repair Record card

FORM 234—
Repair Request Card

forelady or foreman fills out the top of a "Repair Request Card" and gives it to a mechanic. He fills in the time the repair work is started, the parts used and their cost, and the completion time. This data is then transferred to the permanent "Machine Repair Record" kept in the office.

Whichever system is used, management now has an invaluable tool to reduce needless maintenance costs.

Repair Part Inventories

While record keeping tells management which machines require abnormally high maintenance, it does little to help reduce the downtime caused by routine repairs. To alleviate this situation, Union Special recommends that manufacturers establish a formal parts inventory system for each type of sewing machine they operate.

Excessive machine downtime and wasted hours by mechanics can be eliminated with an orderly in-plant inventory of the most commonly needed parts. There is no longer a need to cannibalize other machines for spare parts. Long waits for deliveries are avoided and machine downtime is kept to a minimum. The cost of a parts inventory is small when the overall savings are considered.

Style 39500 QB		
Part Number	Description	Minimum Spare Parts Per Machine
39520 A	Presser foot	1
39530	Presser foot hinge spring	2
39597 A	Presser foot stitch tongue marked "DS"	1
39524 B 3/32	Throat plate marked "V-3/32"	1
or	or	
39524 B 1/8	Throat plate marked "V-1/8"	1
22524	Throat plate screw	2
39526 B	Differential feed dog, 16 teeth per inch	1
39505 B	Main feed dog marked B, 16 teeth per inch	1
39505	Chaining feed dog	1
22528	Screw	2
93 A		2
22797 A		2
39570		4
14077	Upper knife clamp stud	1
39549	Lower knife	4
22588 A	Screw for lower knife clamp	1
39508 B	Lower looper	1
39508 A	Upper looper marked "CC"	1
225646	Screw for upper looper	2
39551 F	Needle clamp stud	1
14077	Nut for needle clamp stud	1
22596 E	Screw for needle driving arm	2
21225 1/8	Looper guage	1
154 GAS	Needles (specify size)	100

SAMPLE
Spare Parts List

For free sample copies of the machine record cards and spare part inventory lists for a variety of the most popular machines, contact your local Union Special Representative or write direct to Union Special.

Catalog No. 97 P

LIST OF PARTS

For Styles

52900 BA 52900 BC
52900 BB 52900 BE
 52900 BJ

First Edition

Copyright 1962
by
Union Special Corporation
Rights Reserved in All Countries

UNION SPECIAL CORPORATION
INDUSTRIAL SEWING MACHINES
CHICAGO

Printed in U.S.A.

September, 1976

FOREWORD

These latest improved famous UNION SPECIAL "Safety Stitch", Class 52900 machines offer many advantages on seaming-overedging operations on various types of garments, such as men's work, service and semi-dress pants, slacks, pillow cases, shoulder pads, jackets, windbreakers, mackinaws, lumberjacks, snow suits, kiddies' overalls, street and house dresses, dungarees, ladies' jeans, pedal pushers, furniture upholstery and seat covers, automobile seat covers with corded welts, vacuum cleaner bags and similar articles.

New light weight parts and needle bearings make them lighter running and smoother operating. A new light weight presser bar mechanism reduces pressure required to lift the foot.

Increased speed has been made possible by design changes and the new filter type oil return pump, used in conjunction with isolated mounting oil pan base plate, which returns any excess oil to reservoir.

It is our constant aim to furnish carefully prepared information which will enable our customers to secure all possible advantages from the use of UNION SPECIAL machines. The following pages illustrate and describe the parts for Styles in Class 52900 - rear disposal of trimmings.

Union Special representatives will be found in all manufacturing centers, ready to cooperate with you to plan and estimate requirements.

UNION SPECIAL CORPORATION
Engineering Department

IDENTIFICATION OF MACHINES

Each UNION SPECIAL carries a Style number which is stamped in the name plate on the machine. Style numbers are classified as standard and special. Standard Style numbers have one or more letters suffixed, but never contain the letter "Z". Example: "Style 52900 BA". Special Style numbers contain the letter "Z". When only minor changes are made in a standard machine, a "Z" is suffixed to the standard Style number. Example: "Style 52900 BAZ".

The distance between the rows of stitches or between needles is represented by a gauge number measured in 1/64ths of an inch, going from left to right. Thus, 5-8 gauge represents a distance of 5/64 inch from left needle (needle for 401 stitch) to middle or left needle of 602 stitch and 8/64 or 1/8 inch from middle needle to extreme right needle. Similarly, 1-5-8 gauge on tandem needle, Style 52900 BJ, represents a distance of 1/64 inch from left row of 401 stitch to right row of 401 stitch, 5/64 inch from right row of 401 stitch to left needle of 602 stitch, and finally, 8/64 or 1/8 inch from left needle of 602 stitch to extreme right needle.

Styles of machines similar in construction are grouped under a class number which differs from the style number in that it contains no letters. Example: "52900".

APPLICATION OF CATALOG

This catalog applies specifically to the standard Styles of machines as listed herein. It can also be applied with discretion to some Special machines in this class. Reference to direction, such as right, left, front, back, etc., are given from the operator's position while seated at the machine. Operating direction of handwheel is toward the operator.

STYLES OF MACHINES

High Speed Streamlined Flat Bed, Medium and High Throw Machines, Vertical Trimmer, Rear Disposal of Trimmings, Light Weight Presser Bar and Needle Bar Driving Mechanism, Three Needles, Left Needle in Rear, Two Loopers, Dual Stitch, Double Locked Stitch on Left, Four Thread Interlock Thread on Right, Unless Otherwise Specified. One Reservoir Enclosed Automatic Lubricating System With Filter Type Oil Return Pump for Main Driving Mechanism, Separate Reservoir for Automatic Lubrication of Spreader Mechanism, Head Oil Siphon Assembly, Lateral Looper Travel.

52900 BA Medium throw machine, for simultaneous seaming and overedging on watch pockets, front and rear pockets on pants, dungarees, and for similar operations on medium to medium heavy weight material. Seam Specification 401 and 602-SSa-2. Type 128 GAS needle. Standard gauge No. 5-8 only.

52900 BB Medium throw machine, for simultaneous seaming and overedging on children's boxer shorts, seersucker, denim and corduroy pants, street and house dresses, shoulder pads, coat linings, pillow cases, and for similar operations on medium to medium heavy weight material. Seam Specification 401 and 602-SSa-2. Type 128 GAS needle. Standard gauges Nos. 5-8, 16-8 and 24-8.

52900 BC High throw machine, for simultaneous seaming and overedging on wind-breakers, mackinaws, lumberjacks, snow suits, and for similar operations on medium heavy to heavy weight material. Overedging applied only to lower ply of fabric. Seam Specification 401 and 602-SSa-2, modified. Type 147 GS needle. Standard gauge No. 16-8.

STYLES OF MACHINES (continued)

52900 BE High throw machine, for simultaneous seaming and overedging with 1/8 inch corded piping on furniture upholstery and seat covers, automobile seat covers, vacuum cleaner bags, and for similar operations on medium heavy to heavy weight material. Seam Specification 401 and 602-SSk-2. Type 147 GS needle. Standard gauges Nos. 12-12 and 16-8.

52900 BJ High throw, four needle, three looper, tandem needle machine, for producing two rows of 401 stitching 1/64 inch apart, and with a Type 602 overedge stitch. Tandem needles mounted to left and rear of two needles abreast, producing Type 602 stitch. The tandem needle arrangement gives an equivalent of 14 stitches per inch on the 401 stitch as compared to 7 stitches per inch on the 602 overedge stitch. Designed to handle materials made of seersucker, denim, corduroy, twill, drill, etc. For in seaming, side seaming, front seaming, seat seaming and pocket seaming on men's work, service and semi-dress pants, dungarees, ladies' jeans, pedal pushers, and for similar operations on medium to heavy weight material. Seam Specification 401 and 602-SSa-3. Type 128 GAS needle. Standard gauge Nos. 1-5-8 and 1-11-12.

NEEDLES

Each needle has a type number and a size number. The type number denotes the kind of shank, point, length, groove, finish, and other details. The size number denotes the largest diameter of the blade, measured in thousandths of an inch, midway between the shank and the eye, and is stamped in the needle shank. Collectively, the type number and size number is the complete symbol.

To have needle orders promptly and accurately filled, forward a sample needle, the empty package, or description on label. A complete order would read as follows: "1000 Needles, Type 128 GAS, Size 100/040".

The type number of the needles recommended for each style of machine covered by this catalog are given in the machine style description. Other needles are available, but the ones indicated are those recommended to produce the most satisfactory results. The type numbers of the recommended needles, together with their descriptions, and the sizes available, are listed below:

<u>TYPE NO.</u>	<u>DESCRIPTION AND SIZES</u>
128 GAS	Round shank, round point, short, double groove, struck groove, ball eye, spotted, chromium plated - sizes 080/032, 090/036, 100/040, 110/044, 125/049, 140/054, 150/060, 170/067.
147 GS	Round shank, round point, long, double groove, struck groove, ball eye, spotted, short point, undersize eye and grooves, one step reduction, chromium plated - sizes 080/032, 090/036, 100/040, 110/044, 125/049, 140/054, 150/060, 170/067.

Selection of the proper needle size should be determined by the size of thread used. Thread should pass freely through needle eye in order to produce a good stitch formation.

ORDERING REPAIR PARTS

ILLUSTRATIONS

This catalog has been arranged to simplify ordering repair parts. Exploded views of various sections of the mechanism are shown so that the parts may be seen in their actual position in the machine. On the page opposite the illustration will be found a listing of the parts with their parts numbers, descriptions, and the number of pieces required in the particular view being shown.

ORDERING REPAIR PARTS (continued)

Numbers in the first column are reference numbers only, and merely indicate the position of that part in the illustration. Reference numbers should never be used in ordering parts. Always use the part number listed in the second column.

Component parts of sub-assemblies, which can be furnished for repairs, are indicated by indenting their descriptions under the description of the main sub-assembly. Example:

59	29476 LE	Looper Driving Lever Crank Assembly-----	1
60	22729 D	Screw, lower -----	2
61	51243 C	Ball Stud Guide-----	1
62	22729 D	Screw -----	1
63	22587	Screw, upper -----	2

It will be noted in the above example that the eccentric and bearing are not listed. The reason is that replacement of these parts individually is not recommended, so the complete sub-assembly should be ordered.

In those cases where a part is common to all of the machines covered by this catalog, no specific usage will be mentioned in the description. However, when the parts for the various machines are not the same, the specific usage will be mentioned in the description, and, if necessary, the difference will be shown in the illustration.

At the back of the book will be found a numerical index of all the parts shown in this book. This will facilitate locating the illustration and description when only the part number is known.

IDENTIFYING PARTS

Where the construction permits, each part is stamped with its part number. On some of the smaller parts, and on those where construction does not permit, an identification letter is stamped in to distinguish the part from similar ones.

Part numbers represent the same part, regardless of catalog in which they appear.

IMPORTANT! ON ALL ORDERS, PLEASE INCLUDE PART NAME AND STYLE OF MACHINE FOR WHICH PART IS ORDERED.

USE GENUINE NEEDLES AND REPAIR PARTS

Success in the operation of these machines can be secured only with genuine UNION SPECIAL Needles and Repair Parts as furnished by the Union Special Corporation, its subsidiaries and authorized distributors. They are designed according to the most approved scientific principles, and are made with utmost precision. Maximum efficiency and durability are assured.

Genuine needles are packaged with labels marked *Union Special*. Genuine repair parts are stamped with the Union Special trademark, US Emblem. Each trademark is your guarantee of the highest quality in materials and workmanship.

TERMS

Prices are net cash and subject to change without notice. All shipments are forwarded f. o. b. shipping point. Parcel Post shipments are insured unless otherwise directed. A charge is made to cover postage and insurance.

OILING AND THREADING

The oil has been drained from the machine before shipping, and the reservoir must be filled before beginning to operate. Use a straight mineral oil with a Saybolt viscosity of 90 to 125 seconds at 100° Fahrenheit.

Oil is filled at the spring cap in the top cover (A) and the level is checked at the sight gauge (B) on the front of the machine. The oil level should be maintained between the red lines on the gauge. The capacity of the oil reservoir is 12 ounces.

The machine is automatically lubricated, and no oiling, other than keeping the main reservoir filled is necessary.

A daily check before the morning start should be made, and oil added if required. Oil which has gone through the machine is filtered and pumped back into the main reservoir, making too frequent oilings unnecessary. Excessive oil in the main reservoir may be drained at the plug screw in the main frame (C), directly under the handwheel.

When oil level rises above the line of gauge (D), and does not recede, this indicates the head oil siphon tube is not functioning properly, and should be checked. Excess oil may be drained from the head by removing plug screw (E).

On the next page is a picture showing the manner in which the 52900 Styles covered in this catalog are threaded. The spreader and looper threading has been enlarged for clarity.

THREADING AND OILING DIAGRAM

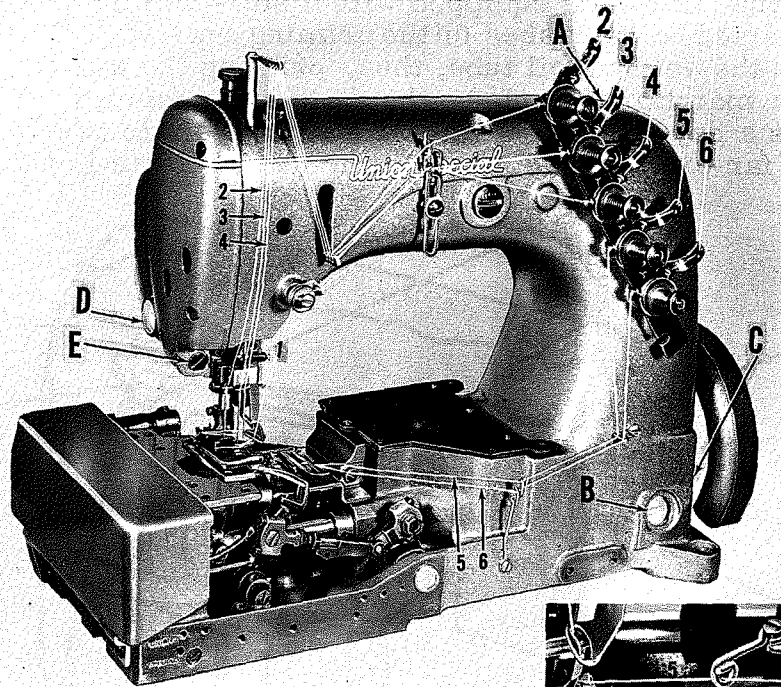

FOR STYLES 52900 BA, BB, BC, BE

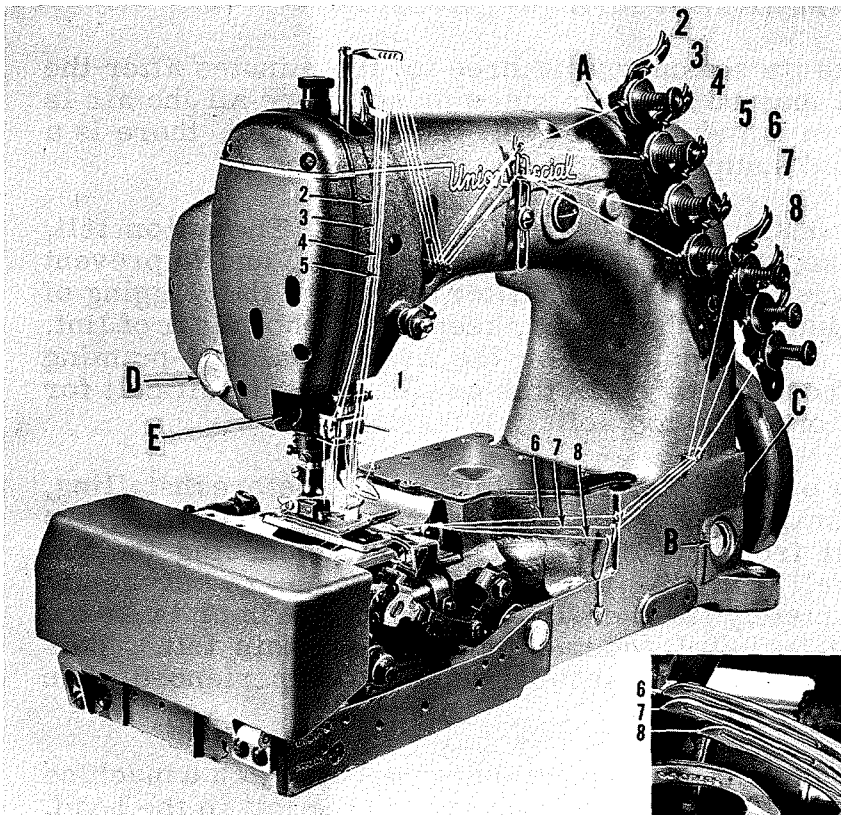
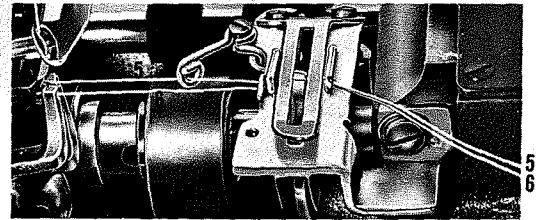

FOR STYLE 52900 BJ

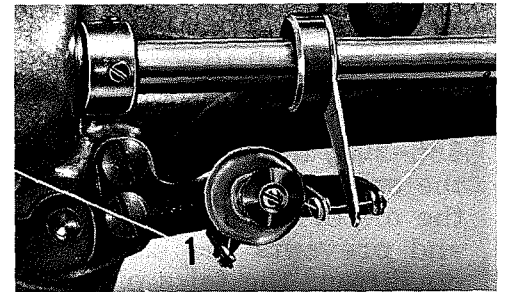

FOR ALL STYLES IN CLASS 52900

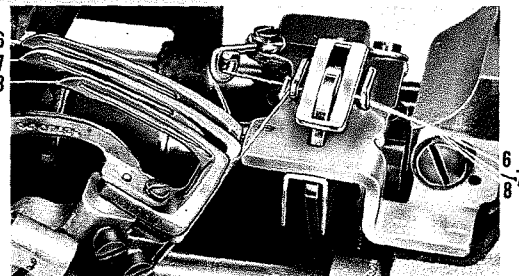

SELF-PRIMING HEAD OIL SIPHON

Class 52900 machines are equipped with a self-priming head oil siphon. When the machine is started, oil splashes on the priming cup felts, filters through the felts, and trickles down the vertical oil tube, thus, priming the siphon. Once the prime is established, it is maintained, unless the felts are removed. The siphon operates twenty-four hours a day, removing oil at the rate of six to twelve drops per minute, which of course, far exceeds the rate at which oil collects in the head.

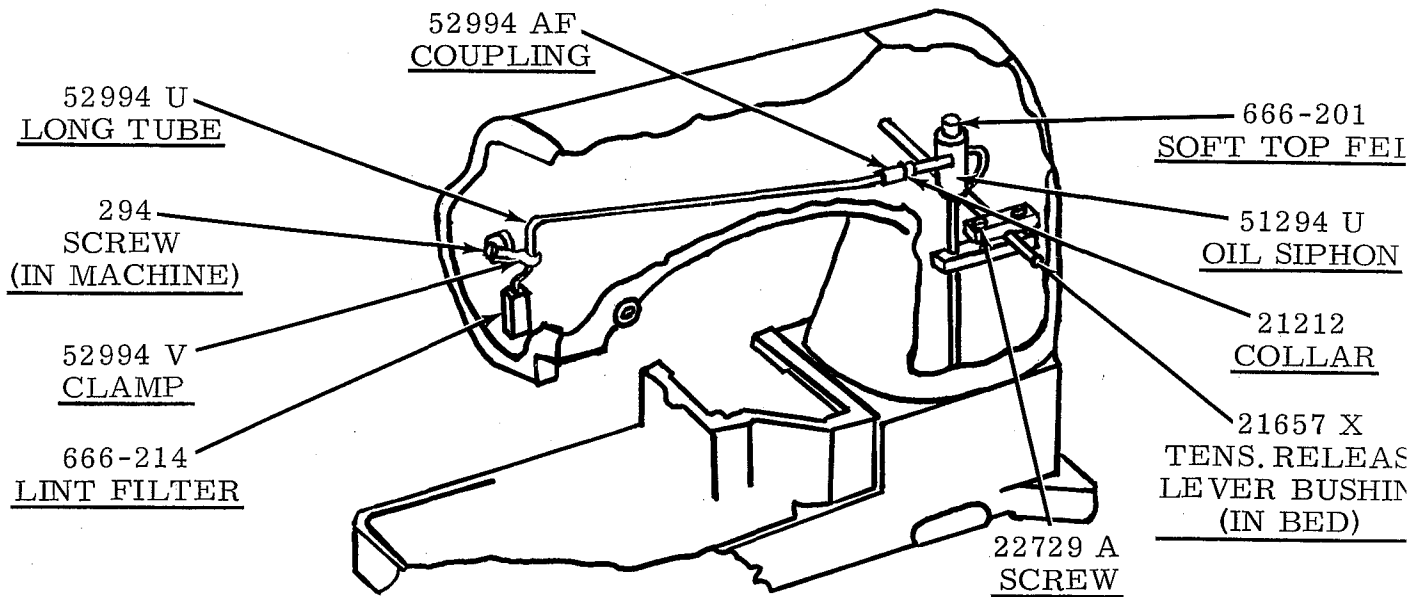

INSTALLING AND MAINTENANCE OF OIL SIPHON

A newly installed siphon starts its action within three to five minutes after the machine is operating. However, it may be twenty minutes or so before all the air is removed from the line and the siphon is in full operation. Within an hour, there is a distinct drop in oil level in the head sump.

The felts in the priming cup are designed for a specific purpose. The bottom felt, 666-209, is thin and relatively dense, to meter the flow of priming oil and to prevent the entrance of air. The softer top felt, 666-201, is a filter to prevent the clogging of the metering felt. This felt, at the intake of the siphon, keeps the siphon clear of lint, and prevents the entrance of air at that point. For the best initial self-priming condition, the felts of the siphon should be dry. In this condition, it is difficult for air to be trapped between the felts or in the top soft felt itself.

However, if for some reason the priming cup felts had been oiled before installing, the siphon may fail because air is trapped between the felts or in the soft top felt. As a precaution, remove the soft felt from the cup. Then, while squeezing the felt between the fingers, saturate it well with oil. In other words, squeeze out the air and replace it with oil. Then, completely fill the cup with oil, and push or twist the soft felt down into cup so that it definitely contacts the harder thin felt. This precaution prevents the trapping of air, and no trouble should be experienced when starting the siphon.

If you want to be doubly sure that the siphon is functioning correctly, on a machine in operation, apply a certain amount of oil in the sump around the felt in the head. Before doing this, be certain that this felt has been saturated in the same manner as explained for the soft felt in the top of the siphon cup. When this is done, the siphoning action will begin, and the oil will be removed as explained.

EXPLODED VIEWS
AND
DESCRIPTION OF PARTS
FOR
CLASS 52900 REAR DISPOSAL

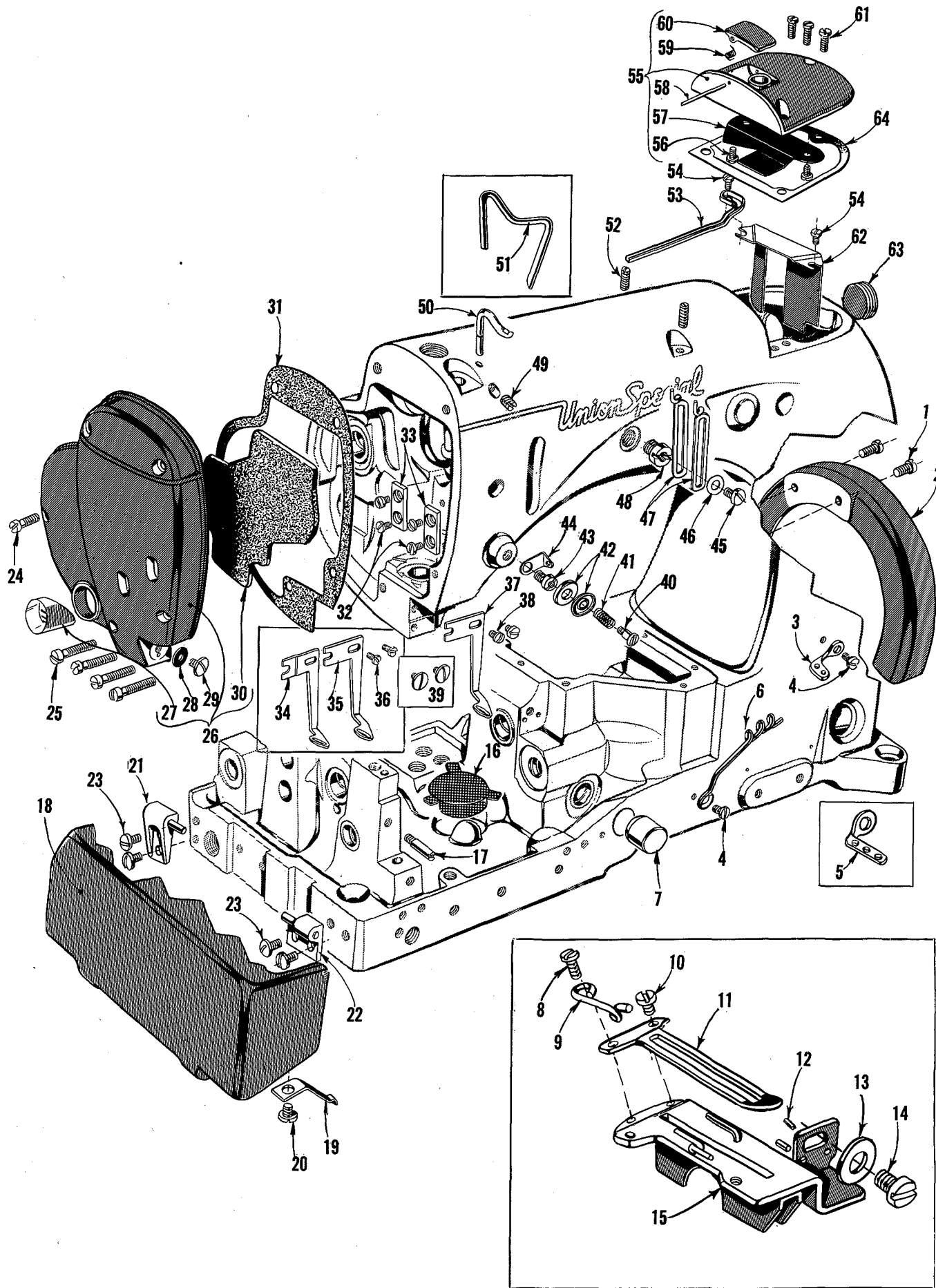

MAIN FRAME, CAST-OFF PLATE, MISCELLANEOUS COVERS AND PLATES

Ref. No.	Part No.	Description	Amt. Req.
1	93	Screw-----	2
2	B21375 AH	Belt Guard-----	1
3	158 B	Looper Thread Eyelet, for all Styles except 52900 BJ-----	1
4	98 A	Screw-----	2
5	158 A	Looper Thread Eyelet, for Style 52900 BJ-----	1
6	52958 G	Frame Thread Eyelet-----	1
7	52942 Y	Looper Rocker Shaft Synchronizing Stud-----	1
8	22768	Screw-----	1
9	52958	Looper Thread Eyelet-----	1
10	28	Screw-----	1
11	52904	Cast-off Wire-----	1
12	50-216 Blk.	Dowel Pin-----	2
13	21657 E	Washer-----	1
14	22528	Screw-----	1
15	52957	Cast-off Plate-----	1
16	51493 BK	Lint Filter Screen-----	1
17	22799 M	Screw-----	1
18	52985	End Cover-----	1
19	52885 L	End Cover Spring-----	1
20	22711	Screw-----	1
21	52885 J	Hinge Bracket, rear-----	1
22	52885 G	Hinge Bracket, front-----	1
23	22848	Screw-----	4
24	22572 A	Screw-----	1
25	294	Screw-----	4
26	52882 R	Head Cover-----	1
27	52894 AN	Oil Gauge-----	1
28	52882 W	Gasket-----	1
29	22542	Screw-----	1
30	52882 Z	Felt Liner-----	1
31	52882 S	Head Cover Gasket-----	1
32	22513	Screw-----	4
33	35731 A	Presser Bar Connection Guide Plate-----	2
34	52944 S	Spreader Thread Guide, for Styles 52900 BC, BE-----	1
35	52844 A	Spreader Thread Guide, for Styles 52900 BA, BB-----	1
36	22849 A	Screw, for Style 52900 BJ-----	2
37	52944 D	Spreader Thread Guide, for Style 52900 BJ-----	1
38	90	Screw, for all Styles except Styles 52900 BB-24-8 and BJ-----	2
39	22542	Screw, for Style 52900 BB-24-8-----	2
40	15438 D	Stud-----	1
41	15438 C	Tension Spring, front-----	1
42	15438 B	Tension Disc-----	2
43	22517 C	Spreader Thread Tension Screw, front-----	1
44	35582 B	Thread Guide-----	1
45	22848	Screw-----	1
46	20	Washer-----	1
47	539	Frame Thread Eyelet-----	2
48	22889 A	Plug Screw-----	1
49	95	Screw-----	1
50	57770	Pull-off Wire, for Style 52900 BA, BB, BJ-----	1
51	51270 B	Pull-off Wire, for Style 52900 BE, BC-----	1
52	719	Screw-----	2
53	51282 AE	Needle Lever Bearing Oiler-----	1
54	90	Screw-----	2
55	52882 AD	Chamber Cover-----	1
56	90	Screw-----	2
57	52882 AA	Drip Plate-----	1
58	50-789 Blk.	Oil Cap Hinge Pin-----	1
59	52882 AC	Oil Cap Torsion Spring-----	1
60	39582 L	Oil Cap-----	1
61	22541 B	Screw-----	3
62	52882 Y	Baffle Plate-----	1
63	22539 D	Plug Screw-----	1
64	52882 P	Gasket-----	1

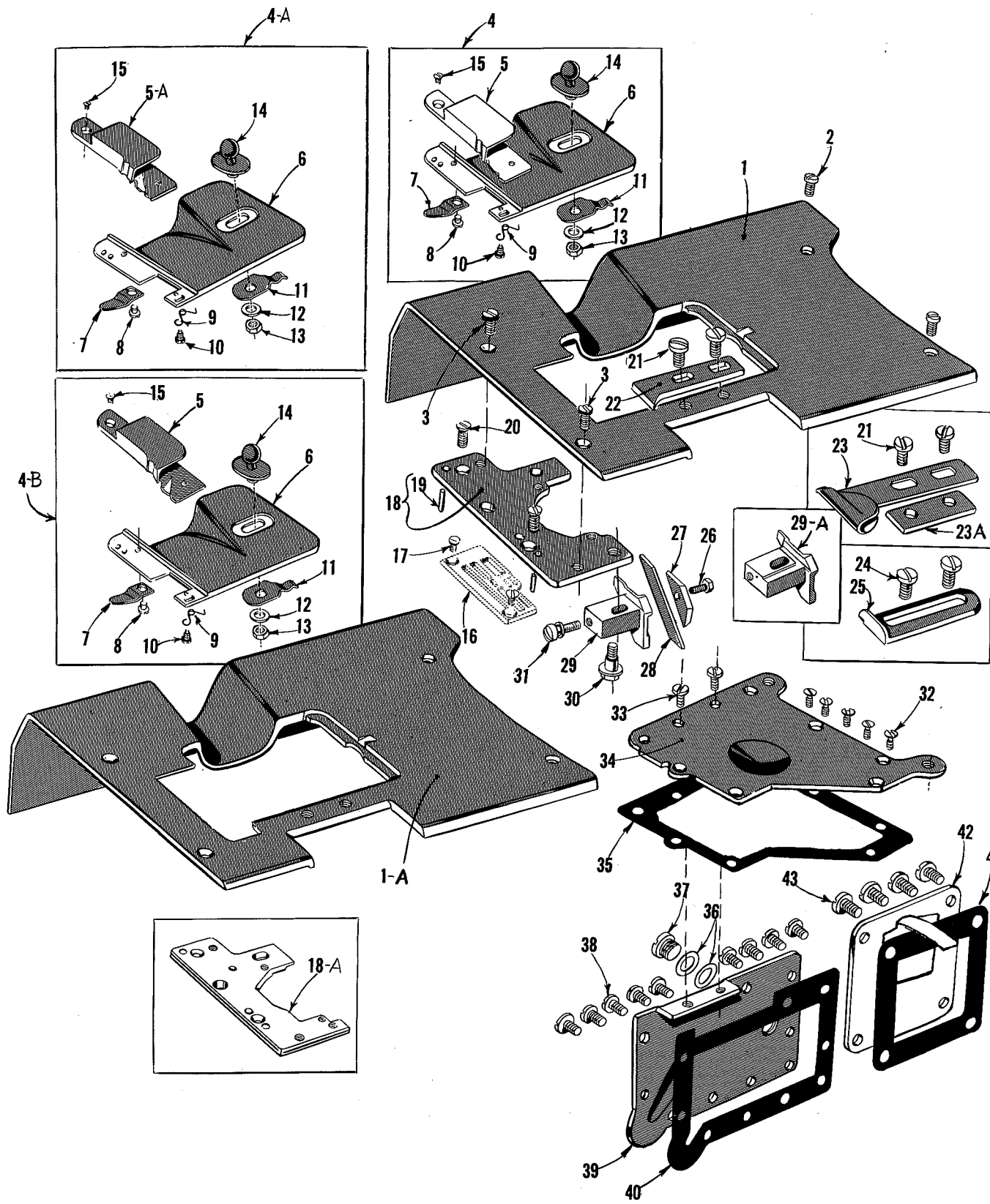

LOWER KNIFE PARTS, CLOTH PLATES AND MISCELLANEOUS COVERS

<u>Ref. No.</u>	<u>Part No.</u>	<u>Description</u>	<u>Amt. Req.</u>
1	52901 G	Cloth Plate, for all Styles except 52900 BJ -----	1
1A	52901 H	Cloth Plate, for Style 52900 BJ-----	1
2	22839 C	Screw -----	2
3	80	Screw -----	2
4	29435 G	Cloth Plate Cover Assembly, for Styles 52900 BC, BE --	1
4A	29435 H	Cloth Plate Cover Assembly, for Styles 52900 BA, BB --	1
4B	29435 K	Cloth Plate Cover Assembly, for Style 52900 BJ -----	1
5	52978 A-8	Chip Guard, for Styles 52900 BA, BB, BJ -----	1
5A	52978 B-8	Chip Guard, for Styles 52900 BC, BE -----	1
6	52981 C	Cloth Plate Cover -----	1
7	356	Cover Spring -----	1
8	22561	Screw -----	1
9	52978 N	Chip Guard Spring -----	1
10	21629	Screw -----	1
11	52981 G	Knob Cover Spring -----	1
12	8372 A	Washer -----	1
13	12934 A	Lock Nut -----	1
14	51381 A	Cover Spring Knob -----	1
15	22599 D	Screw -----	1
16		Throat Plate (See Pages 31, 33) -----	1
17	87	Screw -----	2
18	52980	Throat Plate Support, for all Styles except 52900 BJ----	1
18A	51380 A	Throat Plate Support, for Style 52900 BJ -----	1
19	51280 J	Dowel Pin -----	2
20	22839	Screw -----	2
21	22514	Screw, for Styles 52900 BC, BE -----	2
22	52903	Edge Guide, for Style 52900 BC -----	1
23	52903 C	Welt Guide, for Style 52900 BE -----	1
23A	52903 D	Attachment Plate for welt guide, for Style 52900 BE ----	1
24	25 C	Screw, for Style 52900 BB, No. 16-8 gauge -----	2
25	52903 B	Edge Guide, for Style 52900 BB, No. 16-8 gauge -----	1
26	22588 A	Screw -----	1
27	52950 G	Lower Knife Holder Plate -----	1
28	52949	Knife, lower -----	1
29	52950	Lower Knife Holder Block, for all Styles except 52900 BJ -----	1
29A	52950 C	Lower Knife Holder Block, for Style 52900 BJ -----	1
30	35766	Stud -----	1
31	22568	Screw -----	1
32	22524	Screw -----	5
33	22585 A	Screw -----	2
34	52982 F	Oil Reservoir Top Cover -----	1
35	51382 A	Gasket -----	1
36	41394 A	Gasket -----	2
37	22733 B	Screw -----	1
38	22848	Screw -----	9
39	52982 D	Oil Reservoir Back Cover -----	1
40	52982 E	Gasket -----	1
41	52882 U	Gasket -----	1
42	52882 AF	Crank Chamber Cover -----	1
43	22548	Screw -----	4

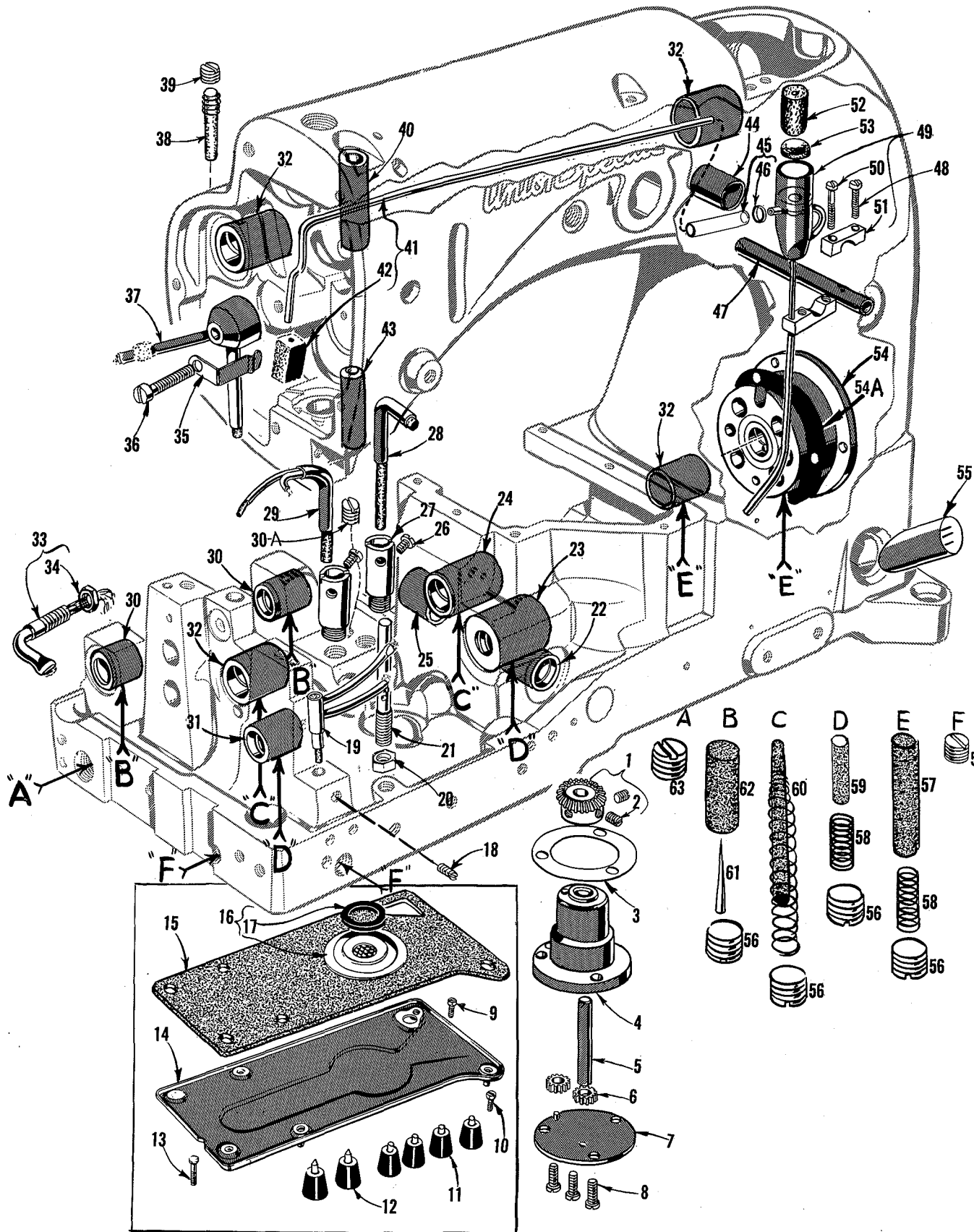

MAIN FRAME, BUSHINGS AND MISCELLANEOUS PARTS

Ref. No.	Part No.	Description	Amt. Req.
1	51493 BQ	Pump Driven Gear -----	1
2	531	Screw -----	2
3	643-127 Blk.	Gasket -----	1
4	51493 AG	Oil Pump Housing -----	1
5	51493 D	Oil Pump Driving Shaft -----	1
6	51493 E	Pump Driving Shaft Gear -----	2
7	51493 AH	Oil Pump Housing Cover -----	1
8	22569 B	Screw -----	3
9	22645 H-64	Screw -----	1
10	22823 A	Screw -----	1
11	39595	Mounting Isolators -----	4
12	51295 B	Mounting Isolators -----	2
13	22823 B	Screw -----	1
14	51493 BB	Oil Pan Base Plate -----	1
15	51493 BG	Base Plate Felt Pad -----	1
16	51493 BH	Filter Cap Assembly -----	1
17	51493 BJ	Washer, sponge rubber -----	1
18	22560 B	Screw -----	1
19	52894 AK	Oil Tube, for looper rocker and left ball joint -----	1
20	258	Nut -----	1
21	15455	Lower Knife Holder Pin Support -----	1
22	52942 W	Looper Drive Lever Shaft Bushing, front -----	1
23	52944 U	Looper Rocker Shaft Bushing, right -----	1
24	51290 T	Main Shaft Bushing, middle -----	1
25	52942 X	Looper Drive Lever Shaft Bushing, rear -----	1
26	90	Screw -----	2
27	52894 AB	Oil Tube Holder -----	2
28	52994 H	Oil Tube, for knife eccentric assembly -----	1
29	52794 G	Oil Tube, for feed lift and looper avoid eccentric -----	1
30	52936	Feed Rocker Shaft Bushing -----	2
30A	22571 B	Plug Screw -----	1
31	52944 T	Looper Rocker Shaft Bushing, left -----	1
32	52890 C	Main Shaft Bushing, left, inner right, and Rocker Shaft Bushing, left, and upper right -----	4
33	660-136	Oil Tube, for feed crank link -----	1
34	258 A	Nut -----	1
35	52994 V	Oil Siphon Clamp -----	1
36	294	Screw -----	1
37	52894 K	Oil Tube Assembly -----	1
38	666-99	Oil Wick, for spreader rocker shaft -----	1
39	22706 A	Plug Screw -----	1
40	51254 C	Needle Bar Bushing, upper -----	1
41	52994 U	Oil Siphon Tube -----	1
42	666-214	Felt Lint Filter -----	1
43	52954 B	Needle Bar Bushing, lower -----	1
44	52883 R	Presser Foot Lifter Lever Bushing -----	1
45	52994 AF	Oil Tube Connection -----	1
46	21212	Oil Siphon Connection Locking Ring -----	2
47	21657 X	Tension Release Lever Shaft Bushing -----	1
48	22729 A	Screw -----	1
49	51294 U	Oil Siphon Assembly -----	1
50	22729 B	Screw -----	1
51	51294 K	Clamp, upper -----	1
52	666-201	Felt Plug -----	1
53	666-209	Felt Plug -----	1
54	52891 B	Crankshaft Bushing Housing, including bushing -----	1
54A	56390 E	Crankshaft Bearing Housing Gasket -----	1
55	50-648 Blk.	Lucite Oil Gauge -----	1
56	22571 A	Plug Screw -----	18
57	666-114	Oil Wick, for right main shaft bearing -----	2
58	35178 D	Spring -----	4
59	666-65	Oil Wick, for looper rocker shaft -----	2
60	666-118	Oil Wick, for left main shaft bearing -----	2
61	666-179	Wedge Pin -----	2
62	666-111	Oil Wick, for feed rocker shaft -----	2
63	22539 H	Plug Screw -----	1

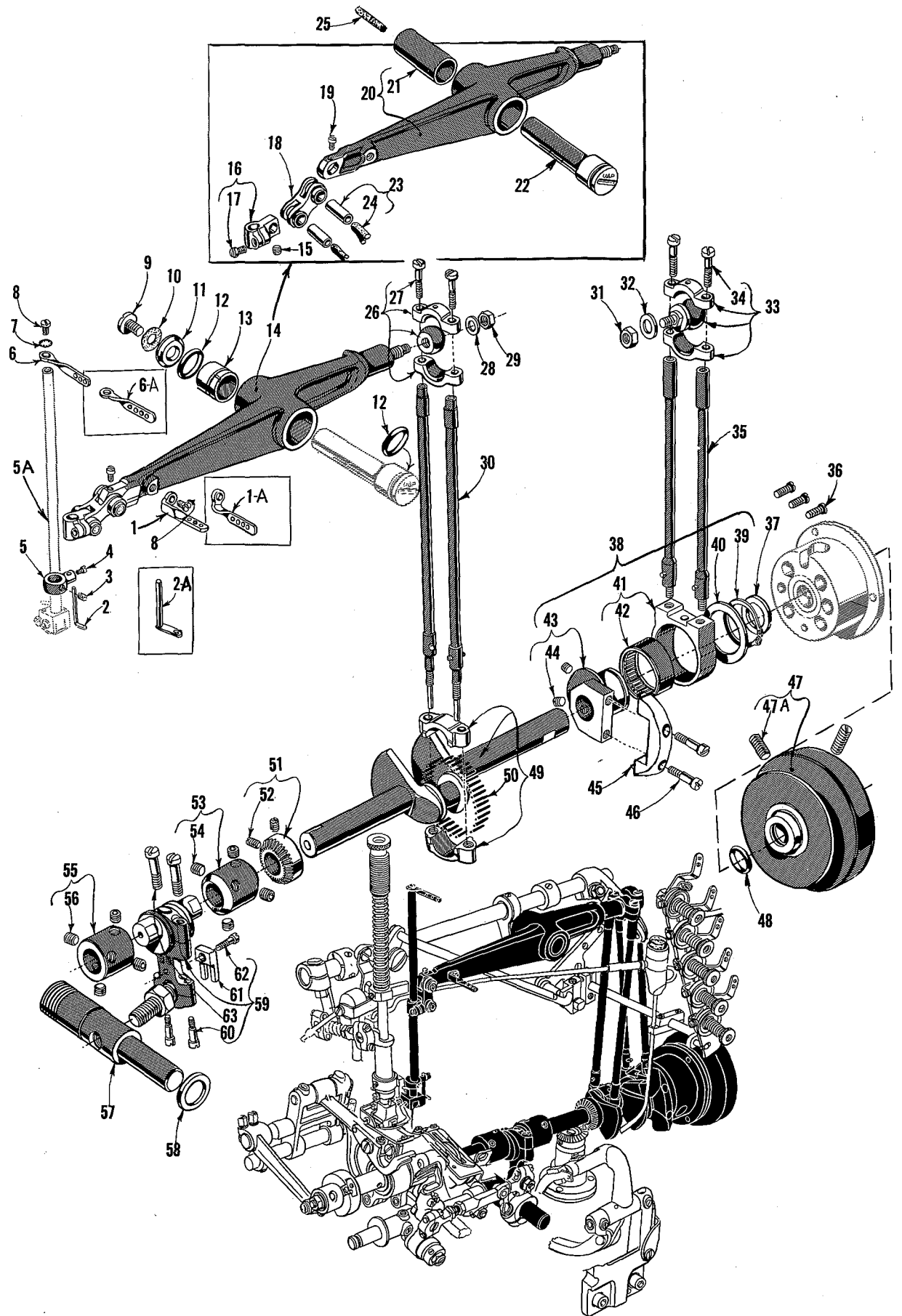

CRANKSHAFT, NEEDLE LEVER AND LOOPER DRIVING PARTS

Ref. No.	Part No.	Description	Amt. Req.
1	56958	Needle Lever Eyelet, for all Styles except 52900 BJ	1
1A	54158	Needle Lever Eyelet, for Style 52900 BJ	1
2	41076 D	Thread Eyelet, for all Styles except 52900 BJ	1
2A	52944 C	Thread Eyelet, for Style 52900 BJ	1
3	22743	Screw	1
4	73 A	Screw	1
5	52842 A	Needle Bar Finger Thread Eyelet Support	1
5A		Needle Bar (See Page 29)	1
6	56958 A	Needle Bar Thread Eyelet, for all Styles except 52900 BJ	1
6A	54158 A	Needle Bar Thread Eyelet, for Style 52900 BJ	1
7	652 C-9	Needle Bar Eyelet Lock Washer	1
8	22768	Screw	2
9	22586 R	Screw	1
10	51250 F	Gasket	1
11	51250 D	Washer	1
12	660-212	Oil Seal Ring	2
13	51150	Needle Lever Shaft Stop Collar	1
14	29348 P	Needle Lever Assembly	1
15	22564	Screw	1
16	51254 J	Needle Bar Connection	1
17	22562 A	Screw	1
18	56354 A	Needle Bar Link	1
19	77	Screw	1
20	56315	Needle Lever	1
21	56350 B	Bushing	1
22	56350 A	Needle Lever Stud	1
23	51054	Link Pin	2
24	666-149	Lubricating Felt	1
*25	666-170	Wick	1
26	29066 R	Needle Lever Connecting Rod and Upper Bearing Assembly	1
27	22559 G	Screw	2
28	51216 N	Washer	1
29	51216 P	Nut	1
30	51216 G	Needle Lever Connecting Rod	2
31	18	Nut	1
32	HA20 A	Washer	1
33	52952 B	Spreader Connector Rod Ball Joint, upper	1
34	22559 G	Screw	2
35	52916	Connecting Rod	2
36	22569 B	Screw	3
37	52951 C	Spacing Washer	1
38	29126 CR	Spreader Drive Eccentric Assembly	1
39	660-246	Tru-Arc Ring	1
40	52951 B	Retaining Washer	1
41	52951 A	Connecting Rod Bearing	1
42	660-244	Needle Bearing	1
43	52951	Spreader Driving Eccentric, .382 inch throw	1
44	95	Screw	2
45	52947 A	Counterweight	1
46	22587 H	Screw	2
47	52921 B	Pulley	1
47A	22894 G	Screw	2
48	660-202	Oil Seal Ring	1
49	29476 HW	Crankshaft Assembly, for Styles 52900 BC, BE, BJ, .990 inch throw	1
	29476 HL	Crankshaft Assembly, for Styles 52900 BA, BB, .910 inch throw	1
50	51216 M	Needle Bearing	28
51	51493 BP	Pump Driving Gear	1
52	22560 B	Screw	2
53	52943 L	Collar	1
54	22894 X	Screw	4
55	56343 D	Collar	1
56	22894 X	Screw	4
57	52942 A	Looper Drive Lever Rocker Shaft	1
58	52951 C	Spacing Washer	1
59	29476 LE	Looper Driving Lever Crank Assembly	1
60	22729 D	Screw, lower	2
61	51243 C	Ball Stud Guide	1
62	22729 D	Screw	1
63	22587	Screw, upper	2

*Not used on late model machines.

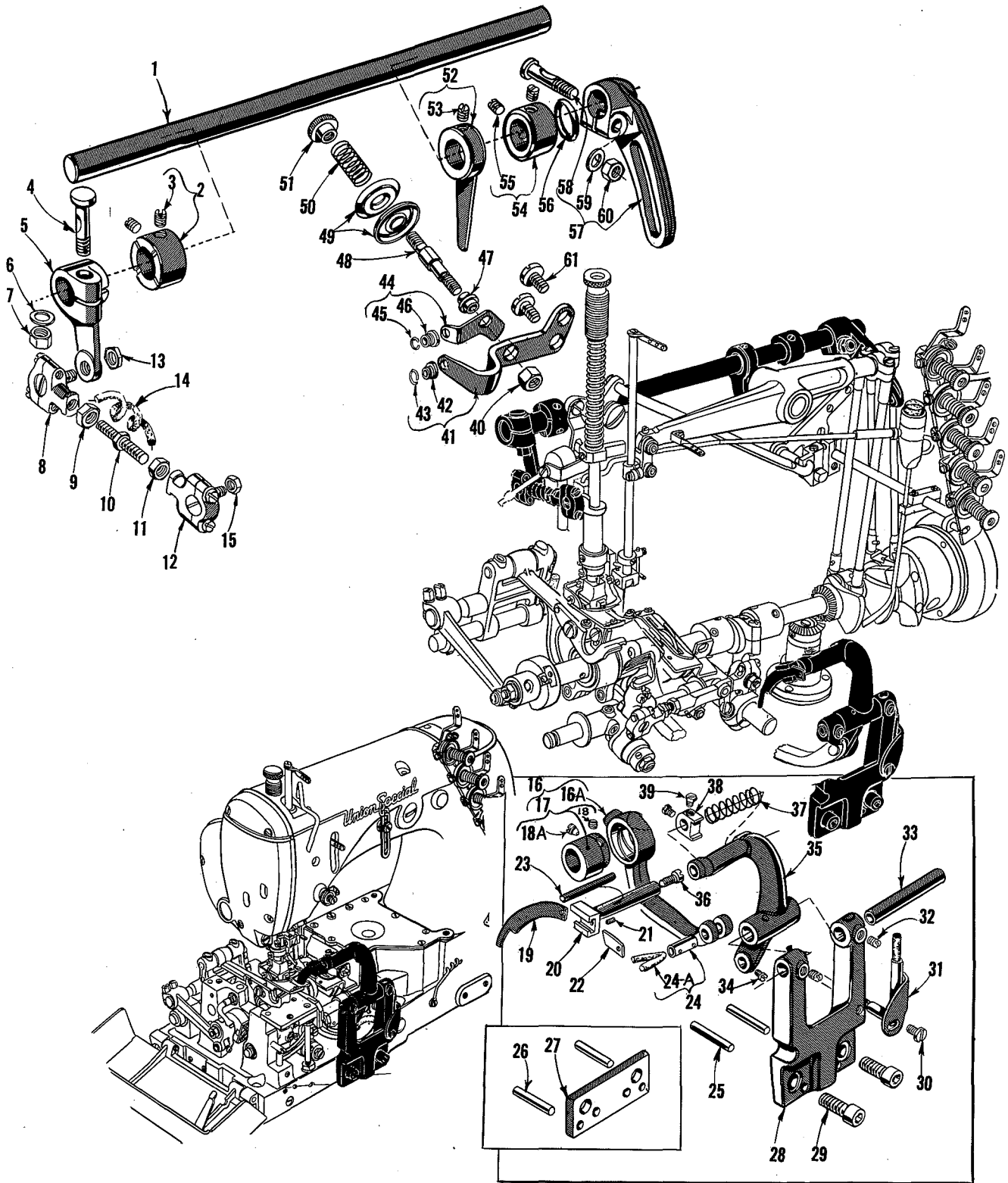

UPPER KNIFE AND SPREADER DRIVE MECHANISM

Ref. No.	Part No.	Description	Amt. Req.
1	52849	Spreader Rocker Shaft-----	1
2	51147	Collar-----	1
3	95	Screw-----	2
4	55235 D	Screw-----	1
5	52849 B	Spreader Rocker Shaft Arm-----	1
6	6042 A	Washer-----	1
7	55235 E	Nut-----	1
8	52848 C	Spreader Connecting Rod Ball Joint, rear-----	1
9	269	Nut, left hand thread-----	1
10	51240 D	Spreader Connecting Rod-----	1
11	18	Nut, right hand thread-----	1
12	52848 B	Spreader Connecting Rod Ball Joint, front-----	1
13	15037 A	Nut-----	1
14	CL21	Oil Wick-----	1
15	12934 A	Nut-----	1
16	29132 Y	Knife Eccentric Assembly, for Styles 52900 BA, BB-----	1
	29132 Z	Knife Eccentric Assembly, for Styles 52900 BC, BE-----	1
	29132 AA	Knife Eccentric Assembly, for Style 52900 BJ-----	1
16A	52974 A	Knife Holder Connecting Rod, for all Styles except 52900 BJ-----	1
	52974 B	Knife Holder Connecting Rod, for Style 52900 BJ-----	1
17	52975 B	Knife Drive Eccentric, for Styles 52900 BA, BB, BJ, .218 inch throw-----	1
	52975 C	Knife Drive Eccentric, for Styles 52900 BC, BE, .276 inch throw-----	1
18	22580 D	Set Screw-----	1
18A	96	Spot Screw-----	1
19	52970 C	Knife, upper-----	1
20	52971 A	Knife Holder-----	1
21	22799 N	Screw-----	1
22	52971 J	Knife Clamp Plate-----	1
23	20149 C	Pin-----	1
24	51054	Link Pin-----	1
24A	666-149	Lubricating Felt-----	1
25	667 C-10	Dowel Pin, for Styles 52900 BA, BB, BC, BE-----	2
26	53564 G	Dowel Pin, for Style 52900 BJ-----	2
27	52973 AA	Knife Bar Bracket Shim, for Style 52900 BJ-----	1
28	51373 AA	Knife Holder Rocker Arm Bracket-----	1
29	22653 E-12	Socket Head Cap Screw-----	2
30	93 A	Screw-----	1
31	51393 E	Oil Tube, for rocker arm bracket shaft-----	1
32	22560 B	Screw-----	2
33	51373 C	Knife Holder Rocker Arm Bracket Shaft-----	1
34	77	Screw-----	1
35	52973 C	Knife Holder Rocker Arm-----	1
36	22516	Screw-----	1
37	51240 C	Knife Holder Spring-----	1
38	52972	Knife Holder Guide Collar-----	1
39	166	Screw-----	2
40	43266	Nut-----	1
41	52855 A	Spreader Thread Pull-off Eyelet-----	1
42	668-25	Eyelet-----	1
43	668-28	Eyelet Locking Ring-----	1
44	51292 D	Thread Tension Eyelet-----	1
45	668-28	Eyelet Locking Ring-----	2
46	668-25	Eyelet-----	2
47	51292 A	Tension Post Ferrule-----	1
48	51292	Spreader Thread Tension Post-----	1
49	109	Tension Disc-----	2
50	51292 F-5	Tension Spring, spreader-----	1
51	51292 C	Tension Post Nut-----	1
52	52855 G	Spreader Thread Pull-off Arm-----	1
53	95	Screw-----	1
54	52849 C	Spreader Rocker Shaft Oil Seal Collar-----	1
55	95	Screw-----	2
56	660-202	Oil Ring-----	1
57	52952 C	Finger Rocker Shaft Lever-----	1
58	55235 D	Screw-----	1
59	6042 A	Washer-----	1
60	55235 E	Nut-----	1
61	22872	Screw-----	2

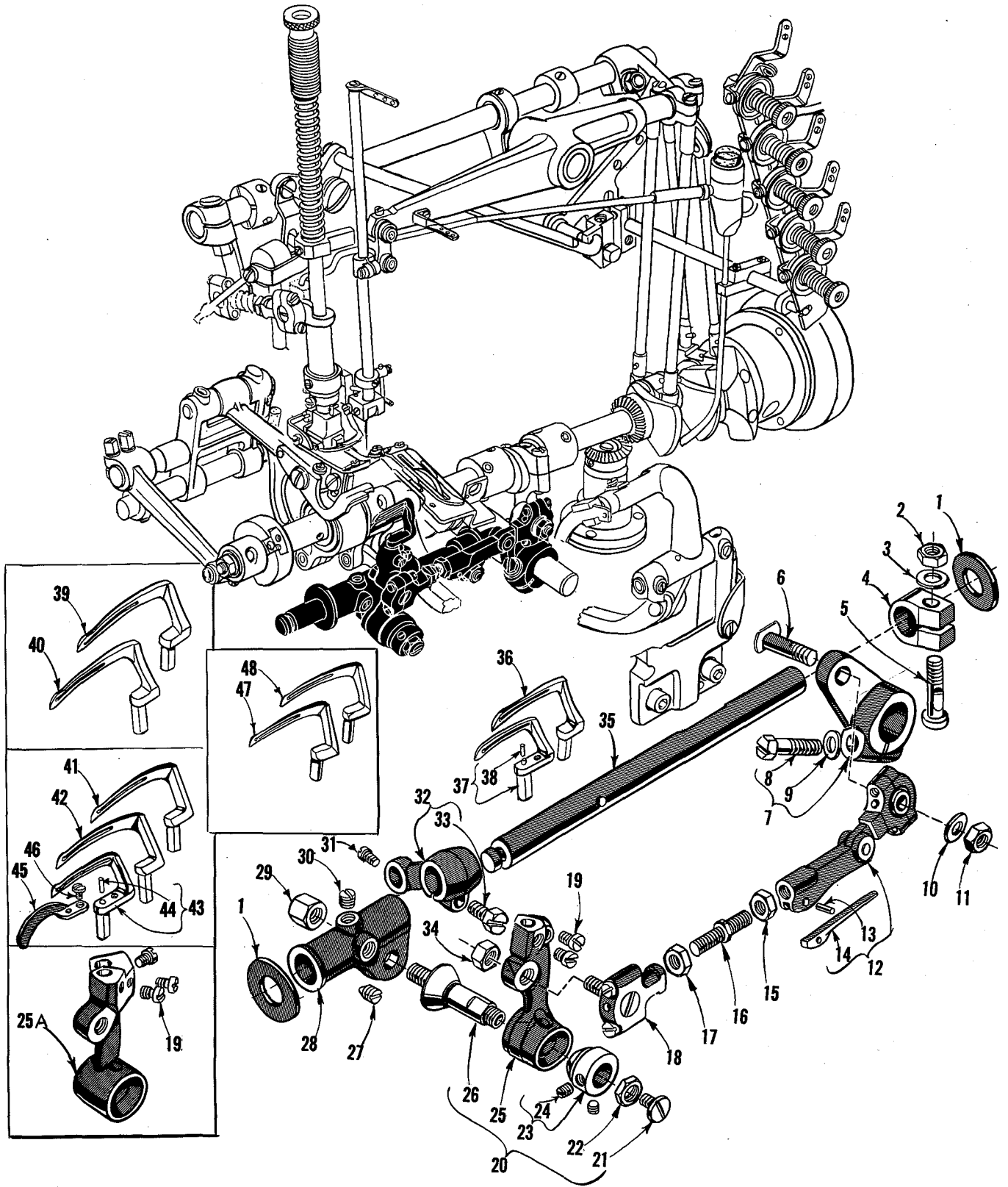

LOOPERS, LOOPER ROCKER AND CONNECTING ROD PARTS

<u>Ref. No.</u>	<u>Part No.</u>	<u>Description</u>	<u>Amt. Req.</u>
1	51244 L	Thrust Washer-----	2
2	18	Nut, right hand thread-----	1
3	20	Washer-----	1
4	51244 N	Looper Rocker Shaft Collar-----	1
5	55244 G	Looper Rocker Shaft Collar Stud-----	1
6	52942 R	Looper Lever Stud-----	1
7	52942 P	Looper Drive Lever-----	1
8	22882 A	Screw-----	1
9	51242 M	Washer-----	1
10	20	Washer-----	1
11	18	Nut, right hand thread-----	1
12	52941 F	Looper Connecting Rod Ball Joint, right-----	1
13	50-458 Blk.	Spring Pin-----	1
14	56341 G	Spring-----	1
15	18	Nut, right hand thread-----	1
16	51240 E	Looper Connecting Rod-----	1
17	269	Nut, left hand thread-----	1
18	52841 A	Looper Connecting Rod Ball Joint, left-----	1
19	73	Screw, for all Styles except 52900 BJ-----	2
	73	Screw, for Style 52900 BJ-----	3
20	29192 G	Looper Rocker Assembly, for all Styles except 52900 BJ--	1
	29192 S	Looper Rocker Assembly, for Style 52900 BJ-----	1
21	22829	Screw-----	1
22	258 A	Lock Nut-----	1
23	15465 F	Looper Rocker Cone-----	1
24	88	Set Screw-----	2
25	52913	Looper Rocker, for all Styles except 52900 BJ-----	1
25A	52913 A	Looper Rocker, for Style 52900 BJ-----	1
26	51745	Looper Rocker Cone Stud-----	1
27	96	Spot Screw-----	1
28	51244	Looper Rocker Frame-----	1
29	51246	Looper Rocker Stud Nut-----	1
30	98	Set Screw-----	1
31	77	Screw-----	1
32	51244 B	Frame Rocker Shaft Arm-----	1
33	22519 H	Screw-----	1
34	18	Nut, right hand thread-----	1
35	51144	Looper Rocker Shaft-----	1
36	52909 A	Looper, back, for No. 5-8 gauge, Styles 52900 BA, BB---	1
37	52808 E	Looper, front, for all Styles except 52900 BJ-----	1
38	1740	Pin-----	1
39	52909 B-24	Looper, back, for No. 24-8 gauge, Style 52900 BB-----	1
40	52909 E-16	Looper, back, for Nos. 12-12 and 16-8 gauge, Styles 52900 BB, BC, BE-----	1
41	52909 D	Looper, back, for No. 1-11-12 gauge, Style 52900 BJ-----	1
42	52908 F-1	Looper, middle, for No. 1-11-12 gauge, Style 52900 BJ---	1
43	52908 D	Looper, front, for No. 1-11-12 gauge, Style 52900 BJ----	1
44	1740	Pin-----	1
45	52910	Looper Needle Guard, for No. 1-11-12 gauge, Style 52900 BJ-----	1
46	73 A	Screw-----	1
47	52908 E-1	Looper, middle, for No. 1-5-8 gauge, Style 52900 BJ----	1
48	52909 C	Looper, back, for No. 1-5-8 gauge, Style 52900 BJ-----	1

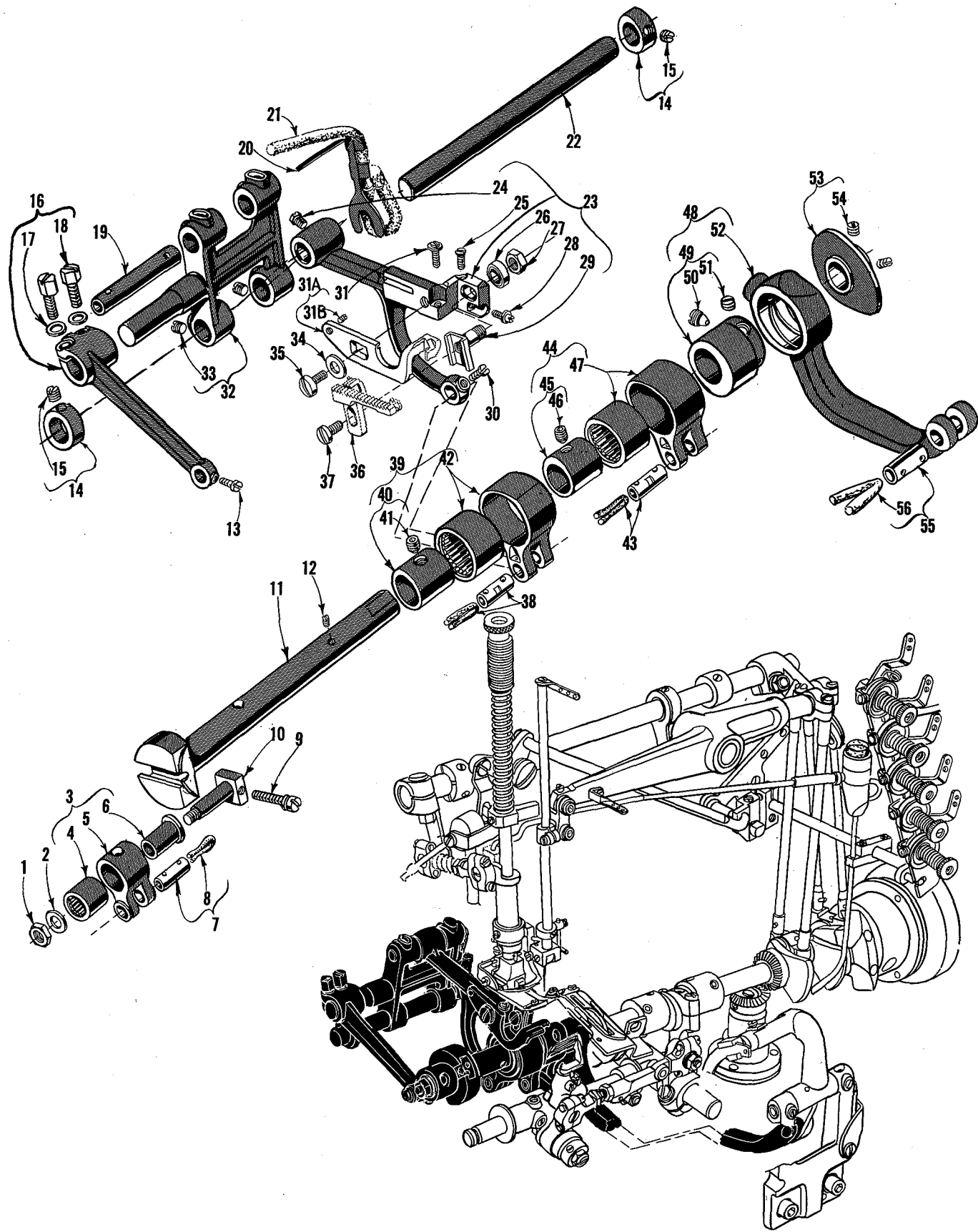

MAIN SHAFT AND FEED MECHANISM

Ref. No.	Part No.	Description	Amt. Req.
1	269	Nut-----	1
2	20	Washer-----	1
3	51236 E	Feed Crank Link Assembly-----	1
4	660-169	Needle Bearing-----	1
5	51236 D	Feed Crank Link-----	1
6	51236 F	Feed Crank Link Ferrule-----	1
7	51054	Link Pin-----	1
8	666-149	Oil Wick-----	1
9	82	Screw-----	1
10	51236 G	Feed Crank Stud-----	1
11	52922 C	Main Shaft-----	1
12	22801	Screw, for take-up-----	1
13	77	Screw-----	1
14	482	Collar-----	2
15	98	Screw-----	2
16	51235 A	Feed Rocker Arm-----	1
17	51235 G	Washer-----	2
18	22519 C	Screw-----	2
19	51134 C	Feed Bar Shaft-----	1
20	51134 R	Lubricating Felt Guard-----	1
21	51134 P	Lubricating Felt-----	1
22	8	Feed Rocker Shaft-----	1
23	51134 A	Tiltable Feed Bar-----	1
24	166	Screw-----	1
25	538	Feed Dog Height Adjusting Screw-----	1
26	51134 J	Feed Dog Holder Washer-----	1
27	258 A	Nut-----	1
28	22863	Feed Dog Holder Adjusting Screw-----	1
29	56334 L	Feed Dog Holder-----	1
30	77	Screw-----	1
31	22834	Needle Guard Adjusting Screw-----	1
31A		Needle Guard (See Page 29)-----	1
31B	22801	Screw-----	1
32	51235	Feed Rocker-----	1
33	98	Screw-----	2
34	51225 W	Washer-----	1
35	22585 B	Screw-----	1
36		Feed Dog (See Pages 31, 33)-----	1
37	22528	Screw-----	1
38	51236 A	Link Pin-----	1
39	29476 DR	Feed Lift Eccentric Assembly-----	1
40	51142 C	Eccentric, .080 inch throw-----	1
41	22894 D	Screw-----	1
42	51145 A	Eccentric Bearing-----	1
43	51236 A	Link Pin-----	1
44	29476 DX	Looper Avoid Eccentric Assembly-----	1
45	51306	Eccentric, .072 inch throw-----	1
46	22894 D	Screw-----	1
47	51145 A	Eccentric Bearing-----	1
48	29132 Y	Knife Eccentric Assembly, for Styles 52900 BA, BB-----	1
	29132 Z	Knife Eccentric Assembly, for Styles 52900 BC, BE-----	1
	29132 AA	Knife Eccentric Assembly, for Style 52900 BJ-----	1
49	52975 B	Knife Drive Eccentric, for Styles 52900 BA, BB, BJ, .218 inch throw-----	1
	52975 C	Knife Drive Eccentric, for Styles 52900 BC, BE, .276 inch throw--	1
50	96	Spot Screw-----	1
51	22580 D	Set Screw-----	1
52	52974 A	Knife Holder Connecting Rod, for all Styles except 52900 BJ-----	1
	52974 B	Knife Holder Connecting Rod, for Style 52900 BJ-----	1
53	52923 C	Take-up-----	1
54	22580	Screw-----	2
55	51054	Link Pin-----	1
56	666-149	Lubricating Felt-----	1

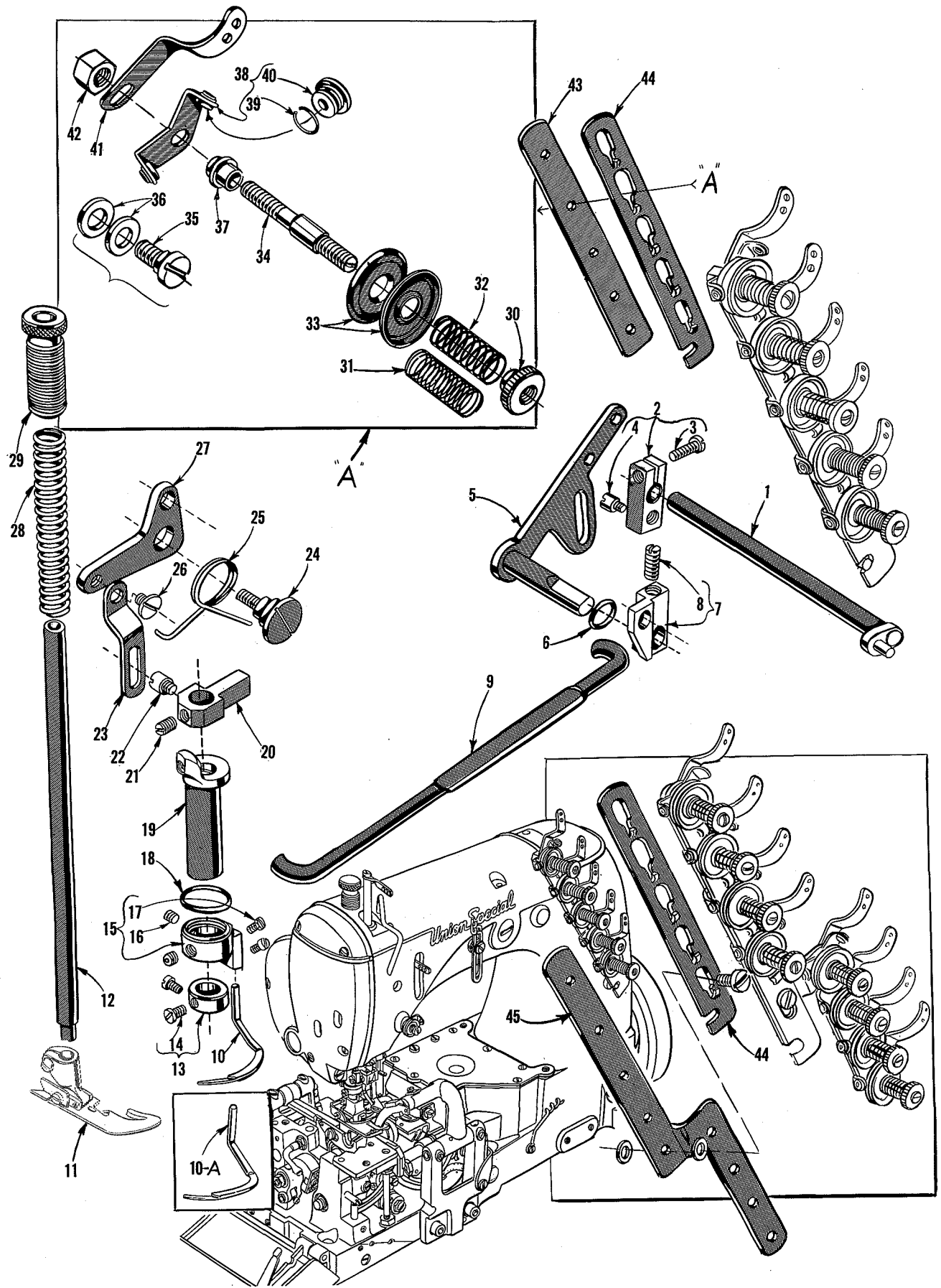

THREAD TENSION, LIFTER LEVER PARTS AND SPREADER HOLDING PARTS

<u>Ref. No.</u>	<u>Part No.</u>	<u>Description</u>	<u>Amt. Req.</u>
1	21657 W	Tension Release Lever Shaft -----	1
2	21657 Y	Tension Release Lever Connection-----	1
3	22596	Screw -----	1
4	402	Screw -----	1
5	51283 H	Presser Foot Lifter Lever-----	1
6	660-207	Oil Ring, for presser foot lifter lever-----	1
7	53783 N	Presser Foot Lifter Lever, internal -----	1
8	22537	Screw -----	1
9	53783 M	Presser Foot Lifter Lever Connecting Rod -----	1
10	52945 M	Spreader, for all Styles except 52900 BJ -----	1
10A	52945 L	Spreader, for Style 52900 BJ-----	1
11		Presser Foot (See Pages 31, 33)-----	1
12	53688	Presser Bar -----	1
13	52888 B	Presser Bar Stop Collar-----	1
14	22562	Screw -----	2
15	52846 A	Spreader Holder -----	1
16	22894 W	Screw -----	2
17	77 A	Screw -----	2
18	660-202	Oil Ring -----	1
19	52847	Spreader Holder Carrier and Lower Presser Bar Bushing-----	1
20	51257 M	Presser Bar Connection and Guide-----	1
21	531	Screw -----	1
22	402	Screw -----	1
23	53783 A	Lifter Lever Link-----	1
24	22557 B	Screw -----	1
25	52883 S	Presser Foot Lifter Lever Bell Crank Spring -----	1
26	22758 C	Screw -----	1
27	53783 L	Presser Foot Lifter Lever Crank-----	1
28	51256 C	Presser Bar Spring -----	1
29	52889 A	Presser Bar Spring Regulator-----	1
30	51292 C	Tension Nut, for all Styles except 52900 BJ-----	5
	51292 C	Tension Nut, for Style 52900 BJ -----	7
31	51292 F-2	Tension Spring, looper, for all Styles except 52900 BJ-----	2
	51292 F-2	Tension Spring, looper, for Style 52900 BJ -----	3
32	51292 F-8	Tension Spring, needle, for all Styles except 52900 BJ-----	3
	51292 F-8	Tension Spring, needle, for Style 52900 BJ -----	4
33	109	Tension Disc, for all Styles except 52900 BJ-----	10
	109	Tension Disc, for Style 52900 BJ -----	14
34	51292 G	Tension Post, for all Styles except 52900 BJ-----	5
	51292 G	Tension Post, for Style 52900 BJ -----	7
35	22598 C	Tension Release Stud, for Style 52900 BJ-----	1
36	80557	Washer, for Style 52900 BJ -----	2
37	51292 A	Tension Post Ferrule, for all Styles except 52900 BJ -----	5
	51292 A	Tension Post Ferrule, for Style 52900 BJ -----	7
38	51292 D	Tension Thread Eyelet, for all Styles except 52900 BJ -----	5
	51292 D	Tension Thread Eyelet, for Style 52900 BJ -----	7
39	668-28	Locking Ring-----	2
40	668-25	Eyelet-----	2
41	51491 C	Thread Lead-In Guide, for all Styles except 52900 BJ-----	5
	51491 C	Thread Lead-In Guide, for Style 52900 BJ -----	7
42	43266	Nut, for all Styles except 52900 BJ -----	3
	43266	Nut, for Style 52900 BJ-----	6
43	52992 A	Tension Post Support, for all Styles except 52900 BJ -----	1
44	21657 AA-4	Tension Disc Separator-----	1
45	51892	Tension Post Support, for Style 52900 BJ-----	1

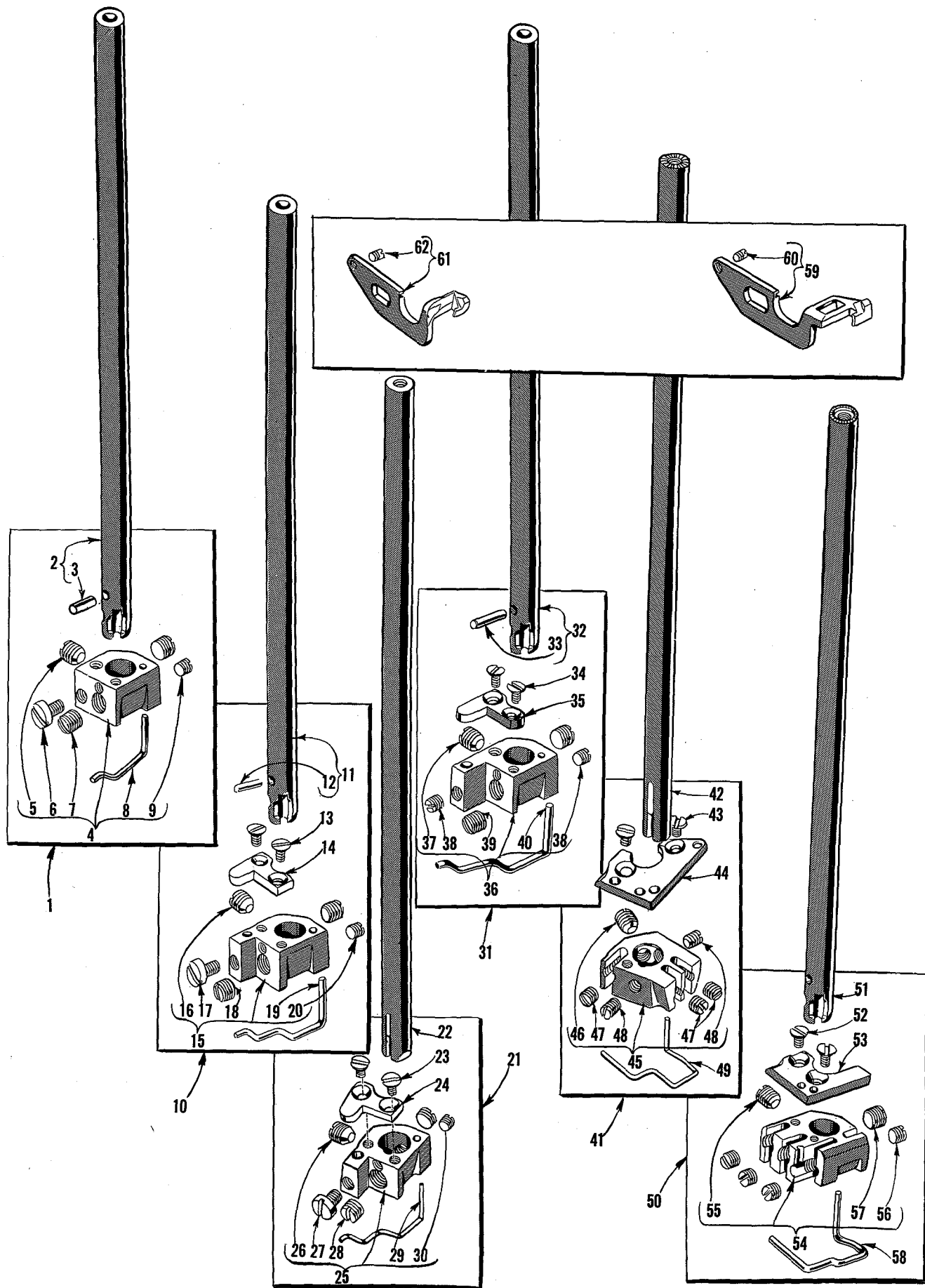

NEEDLE BARS, NEEDLE HOLDERS AND NEEDLE GUARDS

<u>Ref. No.</u>	<u>Part No.</u>	<u>Description</u>	<u>Amt. Req.</u>
1	29264 S-5-8	Needle Bar Assembly, for No. 5-8 gauge, Styles 52900 BA, BB -----	1
2	52917-8	Needle Bar, marked "BE-8"-----	1
3	50 J-16	Needle Stop Pin-----	1
4	52918-5-8	Needle Clamp Collar, marked "AG"-----	1
5	89	Screw, spot-----	1
6	28	Screw, needle set-----	1
7	88 B	Screw, needle set-----	2
8	52842 G	Thread Guide Wire-----	1
9	28 C	Screw-----	1
10	29264 T-16-8	Needle Bar Assembly, for No. 16-8 gauge, Style 52900 BB-----	1
	29264 K-16-8	Needle Bar Assembly, for No. 16-8 gauge, Styles 52900 BC, BE -----	1
11	52917-8	Needle Bar, marked "BE-8", for Style 52900 BB -----	1
	52917 A-8	Needle Bar, marked "CX-8", for Styles 52900 BC, BE -----	1
12	50 J-16	Needle Stop Pin-----	1
13	22716	Screw-----	2
14	52931	Needle Stop Plate, marked "A"-----	1
15	52918-16-8	Needle Clamp Collar, marked "R"-----	1
16	89	Screw, spot-----	1
17	28	Screw, needle set-----	1
18	88 B	Screw, needle set-----	2
19	52942 H	Thread Guide Wire-----	1
20	28 C	Screw-----	1
21	29264 K-12-12	Needle Bar Assembly, for No. 12-12 gauge, Style 52900 BE-----	1
22	51917 A-12	Needle Bar, marked "CX-12"-----	1
23	22716	Screw-----	2
24	52931	Stop Plate, marked "A"-----	1
25	52918-12-12	Needle Clamp Collar, marked "W"-----	1
26	89	Screw, spot-----	1
27	28	Screw, needle set-----	1
28	88 B	Screw, needle set-----	2
29	52942 H	Thread Guide Wire-----	1
30	28 C	Screw-----	1
31	29264 U-24-8	Needle Bar Assembly, for No. 24-8 gauge, Style 52900 BB-----	1
32	52917-8	Needle Bar, marked "BE-8"-----	1
33	50 J-16	Needle Stop Pin-----	1
34	22716	Screw-----	2
35	52931 A	Needle Stop Plate, marked "B"-----	1
36	52918-24-8	Needle Clamp Collar, marked "Y"-----	1
37	89	Screw, spot-----	1
38	28 C	Screw, needle set-----	2
39	88 B	Screw, needle set-----	2
40	52942 J	Thread Guide Wire-----	1
41	29264 W-1-5-8	Needle Bar Assembly, for No. 1-5-8 gauge, Style 52900 BJ-----	1
42	52917 B-1-5-8	Needle Bar, marked "DW"-----	1
43	22716	Screw-----	2
44	52931 B	Stop Plate, marked "D"-----	1
45	52918 A-1-5-8	Needle Clamp Collar, marked "AF"-----	1
46	89	Screw, spot-----	1
47	22743	Screw, needle set-----	3
48	22733	Screw, needle set-----	2
49	52942 L	Thread Guide Wire-----	1
50	29264 W-1-11-12	Needle Bar Assembly, for No. 1-11-12 gauge, Style 52900 BJ-----	1
51	52917 B-1-11-12	Needle Bar, marked "DU"-----	1
52	22716	Screw-----	2
53	52931 C	Stop Plate, marked "C"-----	1
54	52918 A-1-11-12	Needle Clamp Collar, marked "AE"-----	1
55	89	Screw, spot-----	1
56	22743	Screw, needle set-----	4
57	88 B	Screw, needle set-----	1
58	52942 K	Thread Guide Wire-----	1
59	52925 E	Needle Guard, for all gauges, Style 52900 BJ-----	1
60	22801	Pivot Screw-----	1
61	52925 G	Needle Guard, for all Styles except 52900 BJ-----	1
62	22801	Pivot Screw-----	1

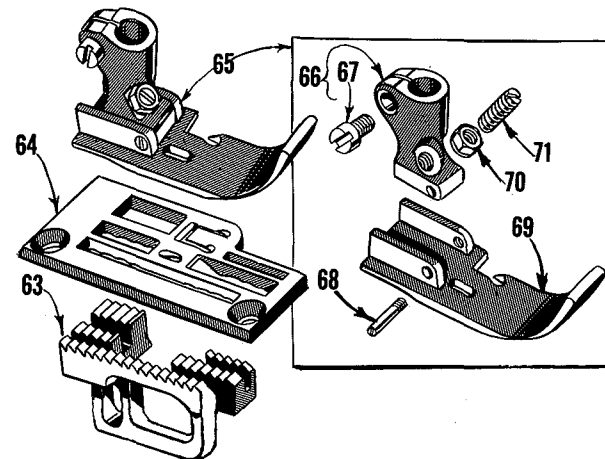
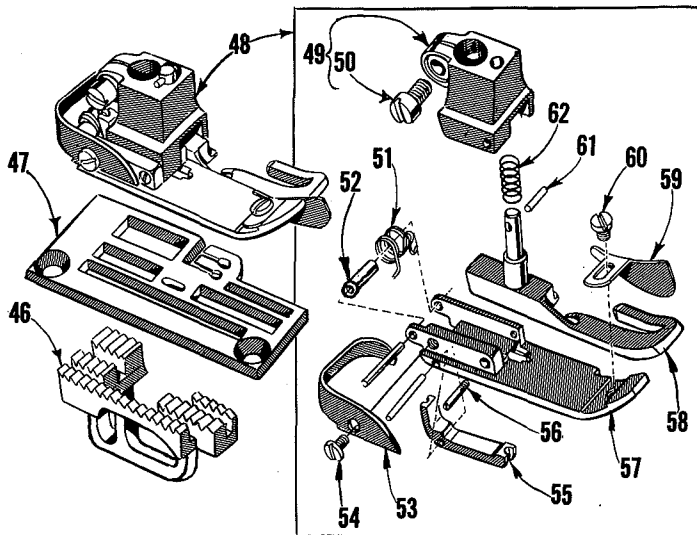
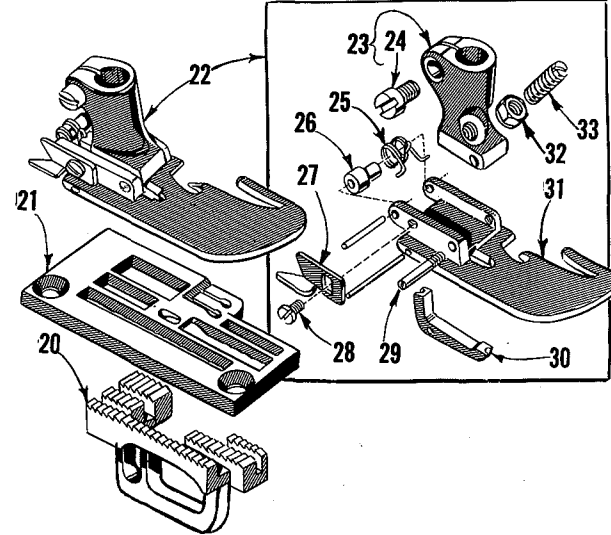
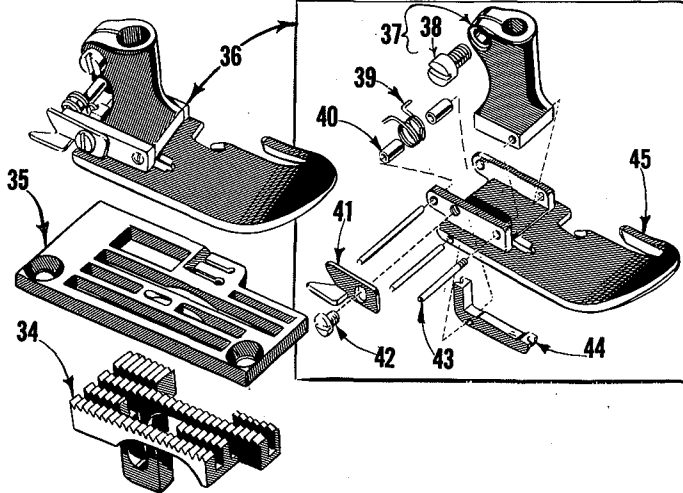
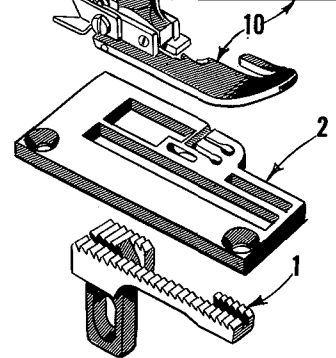
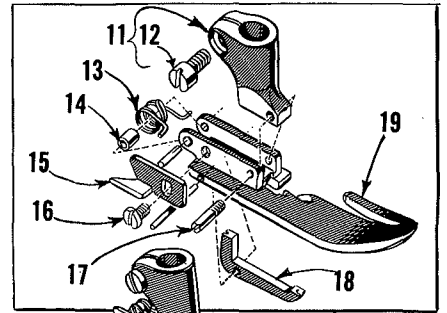
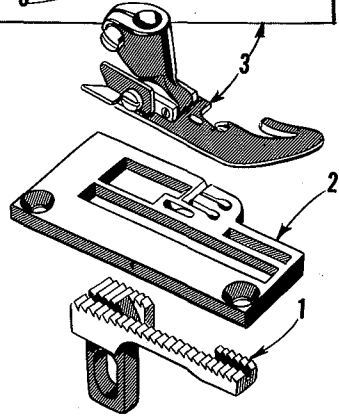
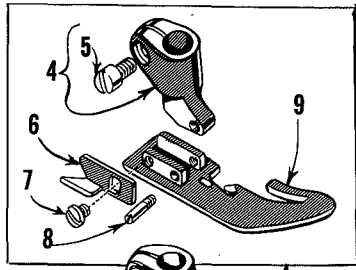

PRESSER FEET, THROAT PLATES AND FEED DOGS

Ref. No.	Part No.	Description	Amt. Req.
1	52905 BH-5-8	Feed Dog, for No. 5-8 gauge, Styles 52900 BA, BB-----	1
2	52924 BH-5-8	Throat Plate, for No. 5-8 gauge, Styles 52900 BA, BB-----	1
3	52920 A-5-8	Presser Foot, for No. 5-8 gauge, Style 52900 BA -----	1
4	52930	Presser Foot Shank -----	1
5	91 A	Screw-----	1
6	52930 AC	Chain Cutting Knife, marked "D" -----	1
7	91 A	Screw-----	1
8	22799 F	Hinge Screw -----	1
9	52930 A	Presser Foot Bottom -----	1
10	52920 B-5-8	Presser Foot, for No. 5-8 gauge, Style 52900 BB -----	1
11	52930	Presser Foot Shank -----	1
12	91	Screw-----	1
13	52930 V	Needle Hole Section Spring -----	1
14	52930 W	Bearing Sleeve-----	1
15	52930 AC	Chain Cutting Knife, marked "D" -----	1
16	604	Screw-----	1
17	22799 F	Hinge Screw -----	1
18	52930 C	Needle Hole Section -----	1
19	52930 B	Presser Foot Bottom -----	1
20	52926 BB-16-8	Feed Dog, for No. 16-8 gauge, Style 52900 BB -----	1
21	52928 A-16-8	Throat Plate, for No. 16-8 gauge, Style 52900 BB -----	1
22	52920 B-16-8	Presser Foot, for No. 16-8 gauge, Style 52900 BB -----	1
23	52930 HA	Presser Foot Shank -----	1
24	91	Screw-----	1
25	52930 V	Needle Hole Section Spring -----	1
26	52930 AG	Bearing Sleeve-----	1
27	52930 AC	Chain Cutting Knife, marked "D" -----	1
28	604	Screw-----	1
29	22799 R	Hinge Screw -----	1
30	52930 J	Needle Hole Section -----	1
31	52930 G	Presser Foot Bottom -----	1
32	51430 F	Lock Nut-----	1
33	22840 A	Adjusting Screw-----	1
34	52926 A-24-8	Feed Dog, for No. 24-8 gauge, Style 52900 BB -----	1
35	52928 A-24-8	Throat Plate, for No. 24-8 gauge, Style 52900 BB -----	1
36	52920 B-24-8	Presser Foot, for No. 24-8 gauge, Style 52900 BB -----	1
37	52930 AD	Presser Foot Shank -----	1
38	91	Screw-----	1
39	52930 V	Needle Hole Section Spring -----	1
40	52930 K	Bearing Sleeve-----	2
41	52930 AC	Chain Cutting Knife, marked "D" -----	1
42	604	Screw-----	1
43	22799 E	Hinge Screw -----	1
44	52930 J	Needle Hole Section -----	1
45	52930 AF	Presser Foot Bottom -----	1
46	52926 C-16-8	Feed Dog, for No. 16-8 gauge, Style 52900 BC and No. 12-12 gauge, Style 52900 BE -----	1
47	52924 C-16-8	Throat Plate, for No. 16-8 gauge, Style 52900 BC -----	1
48	52920 C-16-8	Presser Foot, for No. 16-8 gauge, Style 52900 BC -----	1
49	52930 N	Presser Foot Shank -----	1
50	91	Screw-----	1
51	35778 B	Needle Hole Section Spring -----	1
52	52930 K	Bearing Sleeve-----	1
53	52930 S	Chain Cutting Knife-----	1
54	73 A	Screw-----	1
55	52930 Q	Needle Hole Section -----	1
56	22799 P	Hinge Screw -----	1
57	52930 M	Presser Foot Bottom -----	1
58	52930 P	Yielding Section-----	1
59	52930 R	Guide -----	1
60	91 A	Screw-----	1
61	1740	Pin -----	1
62	52930 T	Yielding Section Spring -----	1
63	52926 C-16-8	Feed Dog, for No. 16-8 gauge, Style 52900 BC and No. 12-12 gauge, Style 52900 BE -----	1
64	52924 C-12-12	Throat Plate, for No. 12-12 gauge, Style 52900 BE -----	1
65	52920 E-12-12	Presser Foot, for No. 12-12 gauge, Style 52900 BE -----	1
66	52930 HA	Presser Foot Shank -----	1
67	91	Screw-----	1
68	22799 R	Hinge Screw -----	1
69	52930 AB-12-12	Presser Foot Bottom -----	1
70	51430 F	Lock Nut-----	1
71	22840 A	Adjusting Screw-----	1

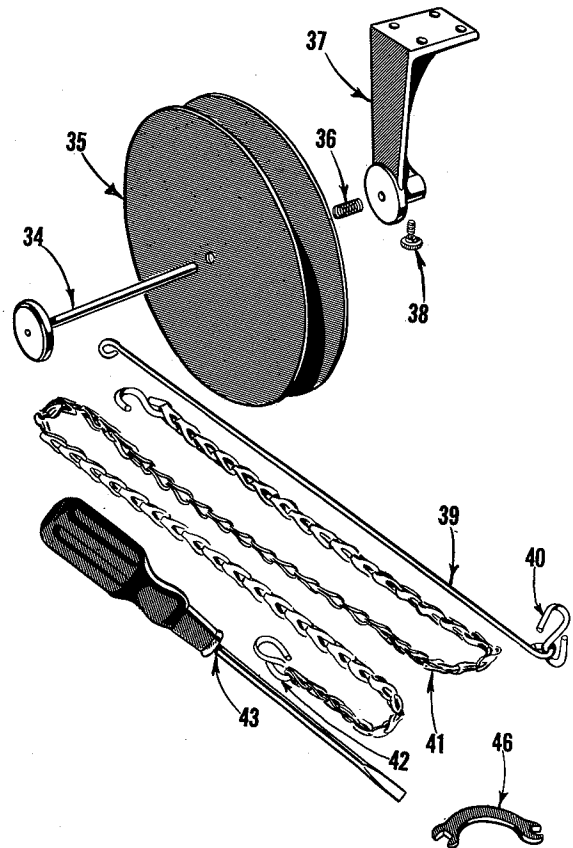
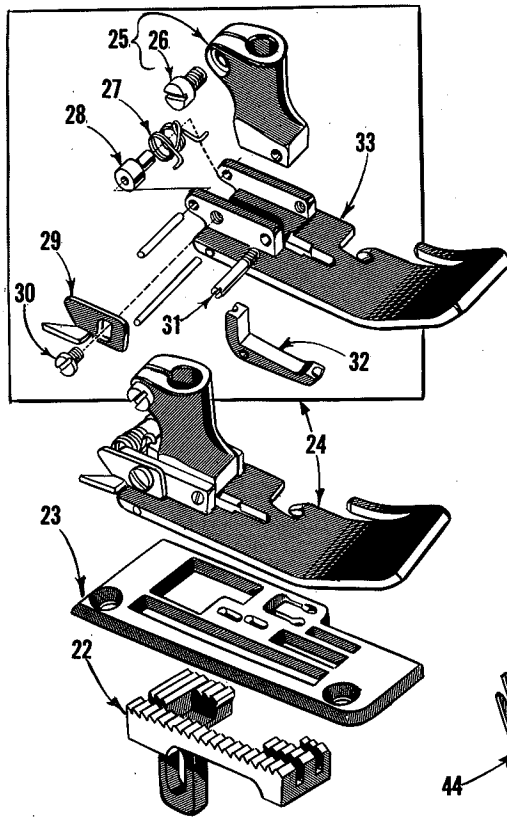
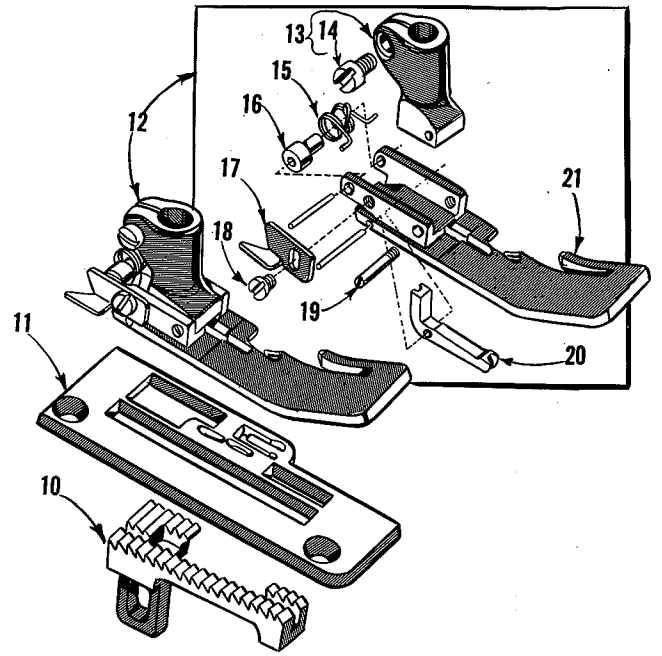
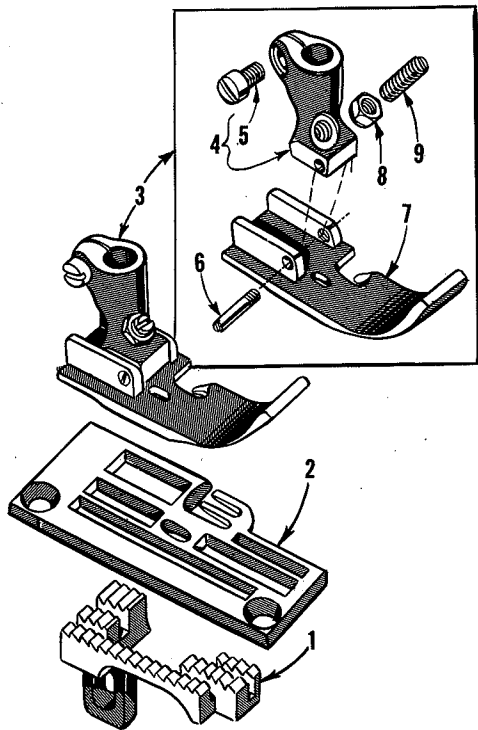

PRESSER FEET, THROAT PLATES, FEED DOGS AND ACCESSORIES

<u>Ref. No.</u>	<u>Part No.</u>	<u>Description</u>	<u>Amt. Req.</u>
1	52905 E-16-8	Feed Dog, for No. 16-8 gauge, Style 52900 BE-----	1
2	52924 E-16-8	Throat Plate, for No. 16-8 gauge, Style 52900 BE---	1
3	52920 E-16-8	Presser Foot, for No. 16-8 gauge, Style 52900 BE--	1
4	52930 HA	Presser Foot Shank-----	1
5	91	Screw-----	1
6	22799 P	Hinge Screw-----	1
7	52930 AB-16-8	Presser Foot Bottom-----	1
8	51430 F	Lock Nut-----	1
9	22840 A	Adjusting Screw-----	1
10	52905 BJ-1-5-8	Feed Dog, for No. 1-5-8 gauge, Style 52900 BJ-----	1
11	52924 BJ-1-5-8	Throat Plate, for No. 1-5-8 gauge, Style 52900 BJ--	1
12	52920 BJ-1-5-8	Presser Foot, for No. 1-5-8 gauge, Style 52900 BJ--	1
13	52930 AP	Presser Foot Shank-----	1
14	91	Screw-----	1
15	52930 V	Needle Hole Section Spring-----	1
16	52930 AG	Spring Ferrule-----	1
17	52930 AC	Chain Cutting Knife, marked "D"-----	1
18	604	Screw-----	1
19	22799 R	Hinge Screw-----	1
20	52930 AM	Needle Hole Section-----	1
21	52930 AN-1-5-8	Presser Foot Bottom-----	1
22	52905 BJ-1-11-12	Feed Dog, for No. 1-11-12 gauge, Style 52900 BJ---	1
23	52924 BJ-1-11-12	Throat Plate, for No. 1-11-12 gauge, Style 52900 BJ-----	1
24	52920 BJ-1-11-12	Presser Foot, for No. 1-11-12 gauge, Style 52900 BJ-----	1
25	52930 H	Presser Foot Shank-----	1
26	91	Screw-----	1
27	52930 V	Needle Hole Section Spring-----	1
28	52930 AG	Spring Ferrule-----	1
29	52930 AC	Chain Cutting Knife, marked "D"-----	1
30	604	Screw-----	1
31	22799 R	Hinge Screw-----	1
32	52930 AM	Needle Hole Section-----	1
33	52930 AN-1-11-12	Presser Foot Bottom-----	1
34	21385 D	Tape Reel Axle, for Style 52900 BE-----	1
35	21178	Tape Reel Disc, for Style 52900 BE-----	2
36	110-3	Tension Spring, for Style 52900 BE-----	1
37	201 A	Tape Reel Support, for Style 52900 BE-----	1
38	201 C	Thumbscrew, for Style 52900 BE-----	1
39	51493 BC	Lifter Link-----	1
40	660-264	"S" Hook, for lifter link-----	1
41	421 D-28	Treadle Chain, for presser foot, 28 inches long----	1
42	660-264	"S" Hook, for treadle chain-----	2
43	21201	Screw Driver, 9/64 inch round blade, length over-all 7 3/8 inches-----	1
44	660-240	Thread Tweezer-----	1
45	21388	Wrench, single end, 3/8 inch opening-----	1
46	21388 W	Wrench, double end, 9/32 inch opening-----	1

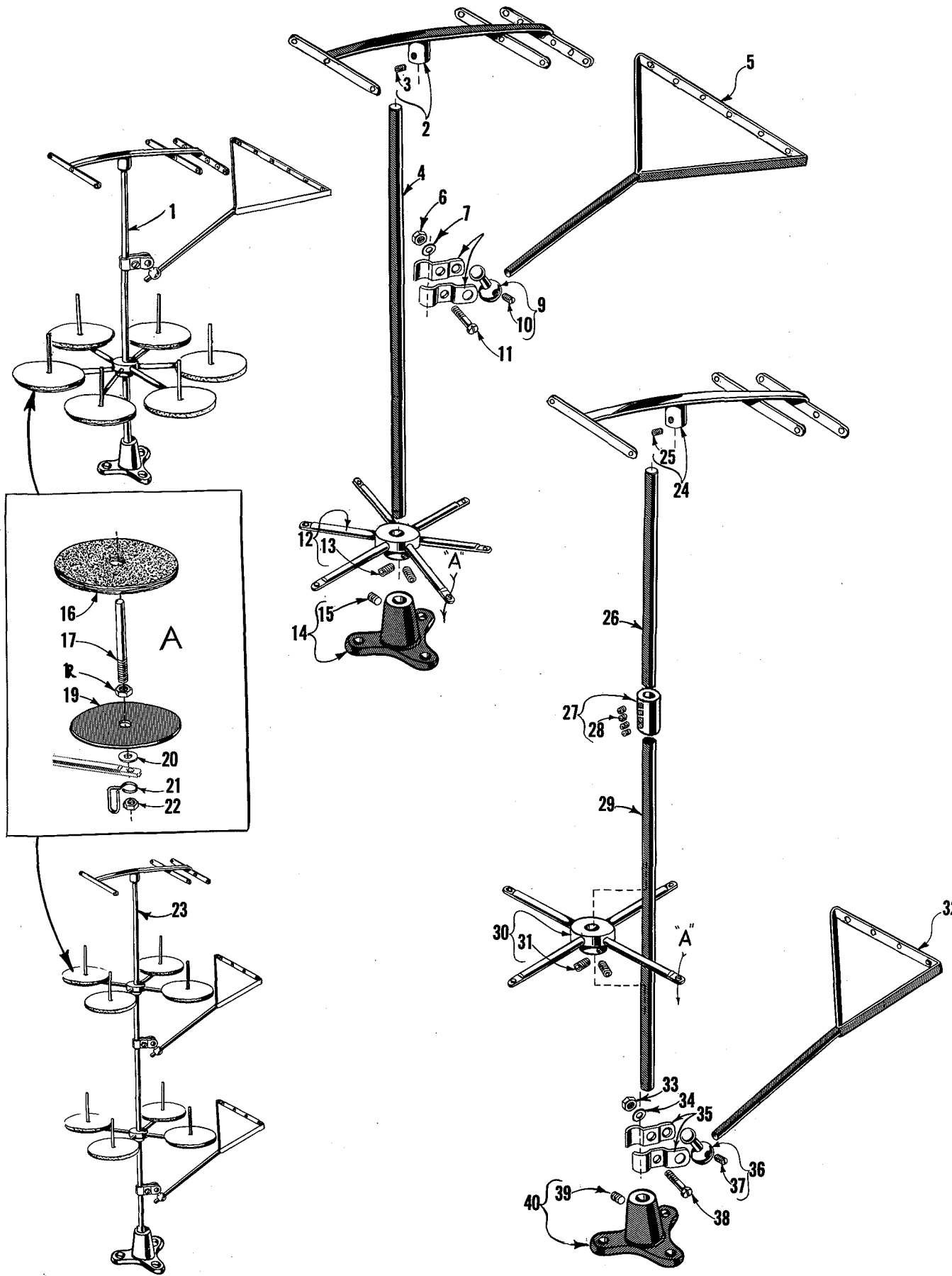

THREAD STANDS

Ref. No.	Part No.	Description	Amt. Req.
1	21101 H-6	Thread Stand, complete, for Styles 52900 BA, BB, BC, BE-	1
2	21114 H-6	Eyelet Support -----	1
3	22651 CD-4	Screw -----	1
4	21104 B-24	Thread Stand Rod-----	1
5	21114 S-6	Lead Eyelet-----	1
6	21104 H	Nut -----	1
7	652-16	Washer-----	1
8	21114 U	Lead Eyelet Ball Split Socket -----	2
9	21114 T	Lead Eyelet Socket Ball -----	1
10	22651 CD-4	Screw -----	1
11	22810	Screw -----	1
12	21114 D-6	Spool Seat Support -----	1
13	22651 CD-5	Screw -----	2
14	21114 A	Thread Stand Base-----	1
15	22651 CD-4	Screw -----	1
16	21104 V	Pad, for 21101 H-6 -----	6
	21104 V	Pad, for 21101 P-8 -----	8
17	21114 W	Spool Pin, for 21101 H-6 -----	6
	21114 W	Spool Pin, for 21101 P-8 -----	8
18	258 A	Nut, for 21101 H-6 -----	6
	258 A	Nut, for 21101 P-8 -----	8
19	21114	Spool Seat Disc, for 21101 H-6-----	6
	21114	Spool Seat Disc, for 21101 P-8-----	8
20	652-16	Washer, for 21101 H-6-----	6
	652-16	Washer, for 21101 P-8-----	8
21	21114 AF	Eyelet, for 21101 P-8-----	4
22	258 A	Nut, for 21101 H-6 -----	6
	258 A	Nut, for 21101 P-8 -----	8
23	21101 P-8	Thread Stand, complete, for Style 52900 BJ -----	1
24	21114 H-4	Eyelet Support -----	1
25	22651 CD-4	Screw -----	1
26	21104 B-11	Thread Stand Rod, upper -----	1
27	21127	Coupling-----	1
28	22651 CD-3	Screw -----	4
29	21104 B-24	Thread Stand Rod, lower -----	1
30	21114 D-4	Spool Seat Support -----	2
31	22651 CD-5	Screw -----	2
32	21114 S-4	Lead Eyelet-----	2
33	21104 H	Nut -----	2
34	652-16	Washer-----	2
35	21114 U	Lead Eyelet Ball Split Socket -----	4
36	21114 T	Lead Eyelet Socket Ball -----	2
37	22651 CD-4	Screw -----	1
38	22810	Screw -----	2
39	21114 A	Thread Stand Base-----	1
40	22651 CD-4	Screw -----	1

NUMERICAL INDEX OF PARTS

Part No.	Page No.	Part No.	Page No.	Part No.	Page No.	Part No.	Page No.
8.....	25	660-244.....	19	22519 H.....	23	22849 A.....	13
18.....	19, 21, 23	660-246.....	19	22524.....	15	22863.....	25
20.....	13, 23, 25	660-264.....	33	22528.....	13, 25	22872.....	21
HA20 A.....	19	666-65.....	17	22537.....	27	22882 A.....	23
CL21.....	21	666-99.....	17	22539 D.....	13	22889 A.....	13
25 C.....	15	666-111.....	17	22593 H.....	17	22894 D.....	25
28.....	13, 29	666-114.....	17	22541 B.....	13	22894 G.....	19
28 C.....	29	666-118.....	17	22542.....	13	22894 W.....	27
50-216 Blk.....	13	666-149.....	19, 21, 25	22548.....	15	22894 X.....	19
50-458 Blk.....	23	666-170.....	19	22557 B.....	27	29066 R.....	19
50-648 Blk.....	17	666-179.....	17	22559 G.....	19	29126 CR.....	19
50-789 Blk.....	13	666-201.....	17	22560 B.....	17, 19, 21	29132 Y.....	21, 25
50 J.....	29	666-209.....	17	22561.....	15	29132 Z.....	21, 25
73.....	23	666-214.....	17	22562.....	27	29132 AA.....	21, 25
73 A.....	19, 23, 31	667 C.....	21	22562 A.....	19	29192 G.....	23
77.....	19, 21, 23, 25	668-25.....	21, 27	22564.....	19	29192 S.....	23
77 A.....	27	668-28.....	21, 27	22568.....	15	29264 K.....	29
80.....	15	719.....	13	22569 B.....	17, 19	29264 S.....	29
82.....	25	1740.....	23, 31	22571 A.....	17	29264 T.....	29
87.....	15	6042 A.....	21	22571 B.....	17	29264 U.....	29
88.....	23	8372 A.....	15	22572 A.....	13	29264 W.....	29
88 B.....	29	12934 A.....	15, 21	22580.....	25	29348 P.....	19
89.....	29	15037 A.....	21	22580 D.....	21, 25	29435 G.....	15
90.....	13, 17	15438 B.....	13	22585 A.....	15	29435 H.....	15
91.....	31, 33	15438 C.....	13	22585 B.....	25	29435 K.....	15
91 A.....	31	15438 D.....	13	22586 R.....	19	29476 DR.....	25
93.....	13	15455.....	17	22587.....	19	29476 DX.....	25
93 A.....	21	15465 F.....	23	22587 H.....	19	29476 HL.....	19
95.....	13, 19, 21	20149 C.....	21	22588 A.....	15	29476 HW.....	19
96.....	21, 23, 25	21101 H.....	35	22596.....	27	29476 LE.....	19
98.....	23, 25	21101 P.....	35	22598 C.....	27	35178 D.....	17
98 A.....	13	21104 B.....	35	22599 D.....	15	35582 B.....	13
109.....	21, 27	21104 H.....	35	22645 H.....	17	35731 A.....	13
110-3.....	33	21104 V.....	35	22651 CD.....	35	35766.....	15
158 A.....	13	21114.....	35	22653 E.....	21	35778 B.....	31
158 B.....	13	21114 A.....	35	22706 A.....	17	39582 L.....	13
166.....	21, 25	21114 D.....	35	22711.....	13	39595.....	17
201 A.....	33	21114 H.....	35	22716.....	29	41076 D.....	19
201 C.....	33	21114 S.....	35	22729 A.....	17	41894 A.....	15
258.....	17	21114 T.....	35	22729 B.....	17	43266.....	21, 27
258 A.....	17, 23, 25, 35	21114 U.....	35	22729 D.....	19	51054.....	19, 21, 25
269.....	21, 23, 25	21114 W.....	35	22733.....	29	51134 A.....	25
294.....	13, 17	21114 AF.....	35	22733 B.....	15	51134 C.....	25
356.....	15	21127.....	35	22743.....	19, 29	51134 J.....	25
402.....	27	21178.....	33	22758 C.....	27	51134 P.....	25
421 D.....	33	21201.....	33	22768.....	13, 19	51134 R.....	25
482.....	25	21212.....	17	22799 E.....	31	51142 C.....	25
531.....	17, 27	B21375 AH.....	13	22799 F.....	31	51144.....	23
538.....	25	21385 D.....	33	22799 M.....	13	51145 A.....	25
539.....	13	21388.....	33	22799 N.....	21	51147.....	21
604.....	31, 33	21388 W.....	33	22799 P.....	31, 33	51150.....	19
643-127 Blk.....	17	21629.....	15	22799 R.....	31, 33	51216 G.....	19
652-16.....	35	21657 E.....	13	22801.....	25, 29	51216 M.....	19
652 C-9.....	19	21657 W.....	27	22810.....	35	51216 N.....	19
660-136.....	17	21657 X.....	17	22823 A.....	17	51216 P.....	19
660-169.....	25	21657 Y.....	27	22823 B.....	17	51225 W.....	25
660-202.....	19, 21, 27	21657 AA.....	27	22829.....	23	51235.....	25
660-207.....	27	22513.....	13	22834.....	25	51235 A.....	25
660-212.....	19	22514.....	15	22839.....	15	51235 G.....	25
660-240.....	33	22516.....	21	22839 C.....	15	51236 A.....	25
		22517 C.....	13	22840 A.....	31, 33	51236 D.....	25
		22519 C.....	25	22848.....	13, 15	51236 E.....	25

NOTE: Only the basic part numbers are shown in the index. For various gauges, capacities, etc. available, refer to the listings on pages indicated.

NUMERICAL INDEX OF PARTS

<u>Part No.</u>	<u>Page No.</u>	<u>Part No.</u>	<u>Page No.</u>	<u>Part No.</u>	<u>Page No.</u>	<u>Part No.</u>	<u>Page No.</u>
51236 F.....	25	52848 B.....	21	52921 B.....	19	52947 A.....	19
51236 G.....	25	52848 C.....	21	52922 C.....	25	52949	15
51240 C.....	21	52849	21	52923 C.....	25	52950	15
51240 D.....	21	52849 B.....	21	52924 C.....	31	52950 C.....	15
51240 E.....	23	52849 C.....	21	52924 E.....	33	52950 G.....	15
51242 M.....	23	52855 A.....	21	52924 BH.....	31	52951 A.....	19
51243 C.....	19	52855 G.....	21	52924 BJ.....	33	52951 B.....	19
51244	23	52882 P.....	13	52925 E.....	29	52951 C.....	19
51244 B.....	23	52882 R.....	13	52925 G.....	29	52952 B.....	19
51244 L.....	23	52882 S.....	13	52926 A.....	31	52952 C.....	21
51244 N.....	23	52882 U.....	15	52926 C.....	31	52954 B.....	17
51246	23	52882 W.....	13	52926 BB.....	31	52957	13
51250 D.....	19	52882 Y.....	13	52928 A.....	31	52958	13
51250 F.....	19	52882 Z.....	13	52930	31	52958 G.....	13
51254 C.....	17	52882 AA.....	13	52930 A.....	31	52970 C.....	21
51254 J.....	19	52882 AC.....	13	52930 B.....	31	52971 A.....	21
51256 C.....	27	52882 AD.....	13	52930 C.....	31	52971 J.....	21
51257 M.....	27	52882 AF.....	15	52930 G.....	31	52972	21
51270 B.....	13	52883 R.....	17	52930 H.....	33	52973 C.....	21
51280 J.....	15	52883 S.....	27	52930 J.....	31	52973 AA.....	21
51282 AE.....	13	52885 G.....	13	52930 K.....	31	52974 A.....	21, 25
51283 H.....	27	52885 J.....	13	52930 M.....	31	52974 B.....	21, 25
51290 T.....	17	52885 L.....	13	52930 N.....	31	52975 B.....	21, 25
51292	21	52888 B.....	27	52930 P.....	31	52975 C.....	21, 25
51292 A.....	21, 27	52889 A.....	27	52930 Q.....	31	52978 A.....	15
51292 C.....	21, 27	52890 C.....	17	52930 R.....	31	52978 B.....	15
51292 D.....	21, 27	52891 B.....	17	52930 S.....	31	52978 N.....	15
51292 F.....	21, 27	52894 K.....	17	52930 T.....	31	52980	15
51292 G.....	27	52894 AB.....	17	52930 V.....	31, 33	52981 C.....	15
51294 K.....	17	52894 AK.....	17	52930 W.....	31	52981 G.....	15
51294 U.....	17	52894 AN.....	13	52930 AB.....	31, 33	52982 D.....	15
51295 B.....	17	52901 G.....	15	52930 AC.....	31, 33	52982 E.....	15
51306	25	52901 H.....	15	52930 AD.....	31	52982 F.....	15
51373 C.....	21	52903	15	52930 AF.....	31	52985	13
51373 AA.....	21	52903 B.....	15	52930 AG.....	31, 33	52992 A.....	27
51380 A.....	15	52903 C.....	15	52930 AM.....	33	52994 H.....	17
51381 A.....	15	52903 D.....	15	52930 AN.....	33	52994 U.....	17
51382 A.....	15	52904	13	52930 AP.....	33	52994 V.....	17
51393 E.....	21	52905 E.....	33	52930 HA.....	31, 33	52994 AF.....	17
51430 F.....	31, 33	52905 BH.....	31	52931	29	53564 G.....	21
51491 C.....	27	52905 BJ.....	33	52931 A.....	29	53688	27
51493 D.....	17	52908 D.....	23	52931 B.....	29	53783 A.....	27
51493 E.....	17	52908 E.....	23	52931 C.....	29	53783 L.....	27
51493 AG.....	17	52908 F.....	23	52936	17	53783 M.....	27
51493 AH.....	17	52909 A.....	23	52941 F.....	23	53783 N.....	27
51493 BB.....	17	52909 B.....	23	52942 A.....	19	54158	19
51493 BC.....	33	52909 C.....	23	52942 H.....	29	54158 A.....	19
51493 BG.....	17	52909 D.....	23	52942 J.....	29	55235 D.....	21
51493 BH.....	17	52909 E.....	23	52942 K.....	29	55235 E.....	21
51493 BJ.....	17	52910	23	52942 L.....	29	55244 G.....	23
51493 BK.....	13	52913	23	52942 P.....	23	56315	19
51493 BP.....	19	52913 A.....	23	52942 R.....	23	56334 L.....	25
51493 BQ.....	17	52916	19	52942 W.....	17	56341 G.....	23
51745	23	52917	29	52942 X.....	17	56343 D.....	19
51892	17	52917	29	52942 Y.....	13	56350 A.....	19
52794 G.....	17	52917 A.....	29	52943 L.....	19	56350 B.....	19
52808 E.....	23	52917 B.....	29	52944 C.....	19	56354 A.....	19
52841 A.....	23	52918	29	52944 D.....	13	56958	19
52842 A.....	19	52918 A.....	29	52944 S.....	13	56958 A.....	19
52842 G.....	29	52920 A.....	31	52944 T.....	17	56390 E.....	17
52844 A.....	13	52920 B.....	31	52944 U.....	17	57770	13
52846 A.....	27	52920 C.....	31	52945 L.....	27	80557	27
52847	27	52920 E.....	31, 33	52945 M.....	27		
		52920 BJ.....	33				

NOTE: Only the basic part numbers are shown in the index. For various gauges, capacities, etc., available, refer to the listings on pages indicated.

Helpful, authoritative information on the most efficient types of equipment for making virtually any machine sewed article is available from Union Special's Sales Promotion Department. Among the many interesting, illustrated bulletins that are available without obligation are the following:



- No. 240, "Men's, Women's, Children's Footwear"
- No. 249, "Rainwear"
- No. 250, "Men's Dress Shirts"
- No. 251, "Service Shirts and Pants"
- No. 252, "Men's Shorts and Pajamas"
- No. 253, "Overalls, Coveralls, and Dungarees"
- No. 254, "Men's Knit Underwear"
- No. 256, "Knit Outerwear"
- No. 259, "Men's Sports Shirts"
- No. 260, "Work Gloves"
- No. 262, "Cotton, Burlap, Jute, and Multiwall Paper Bags"
- No. 263, "Men's Clothing"
- No. 264, "Men's Women's, Children's Jackets"
- No. 265, "Women's Wear"
- No. 266, "Women's Wear And High Fashion"
- No. 267, "Corsets, Girdles, Brassieres"
- No. 268, "Children's Wear"
- No. 269, "Mattresses, Slip Covers, Furniture Upholstery"
- No. 271, "Awnings, Canopies, Tents, Tarps"
- No. 273, "Curtains & Drapes"
- No. 610, "Klipp-it"
- No. 710, "MCS ForMation Unit"
- No. 730, "MCS Automatic Dual Underfront Shirt Hemmer"
- No. 740, "MCS Automatic Rib-Knit Cuff Machine"
- No. 750, "Fusing Presses"
- No. 1100, "Lewis Blindstitch, Chainstitch, Lockstitch, Machines"
- No. 1105, "Button Sewers—Ticket Tackers"
- "Columbia Blindstitch, Saddle Stitch, and Tie Closing Machines"
- No. 1500, "Alteration Department Machines"



**UNION SPECIAL
CORPORATION**

**HERE ARE HELPFUL
BULLETINS and CATALOGS
TO HELP YOU SOLVE
SEWING PROBLEMS**



BOOST PRODUCTION WITH THESE WORK AIDS FROM UNION SPECIAL

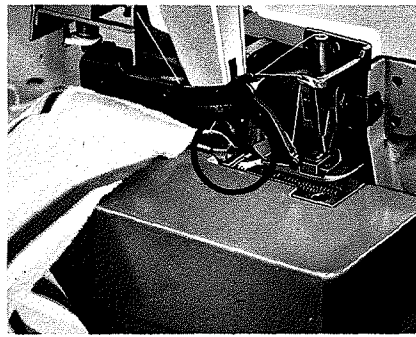

PNEUMATIC CHAIN-CUTTER—for use on conventional Class 39500 and 39600 is a durable scissor-action mechanism that makes a clean positive cut. Style 2899 A-1

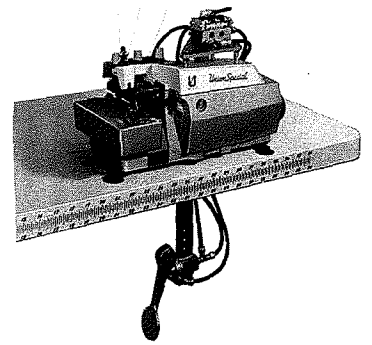

PNEUMATIC FOOT LIFTER—The air-operated foot lifter for use on Class 39500 machines allows the operator to raise the foot simply by knee-touching an actuating switch.

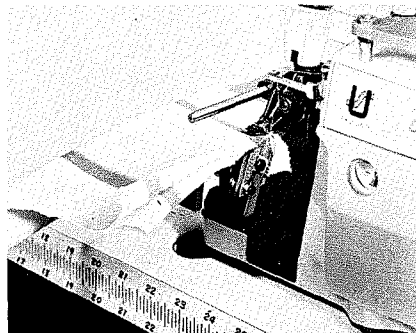

AIR FABRIC UNCURLER—This unit, designed for Class 39500 machines, uses air jets to remove curls from top and bottom plies of flat knit materials as fabric passes through sewing area. Style 2899 B-1

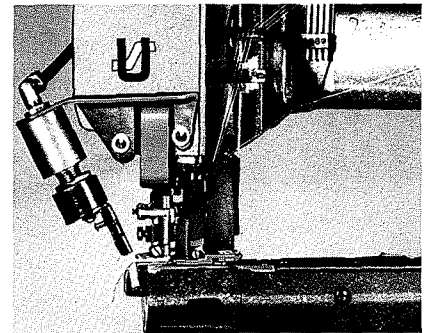

CHAIN CUTTER—The above photo shows the small pneumatic chain cutter that is available for installation as an accessory unit on Class 36200 Flatseamers. Style 2899 A-6

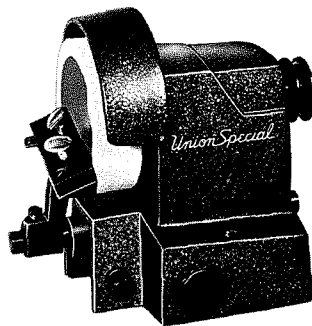
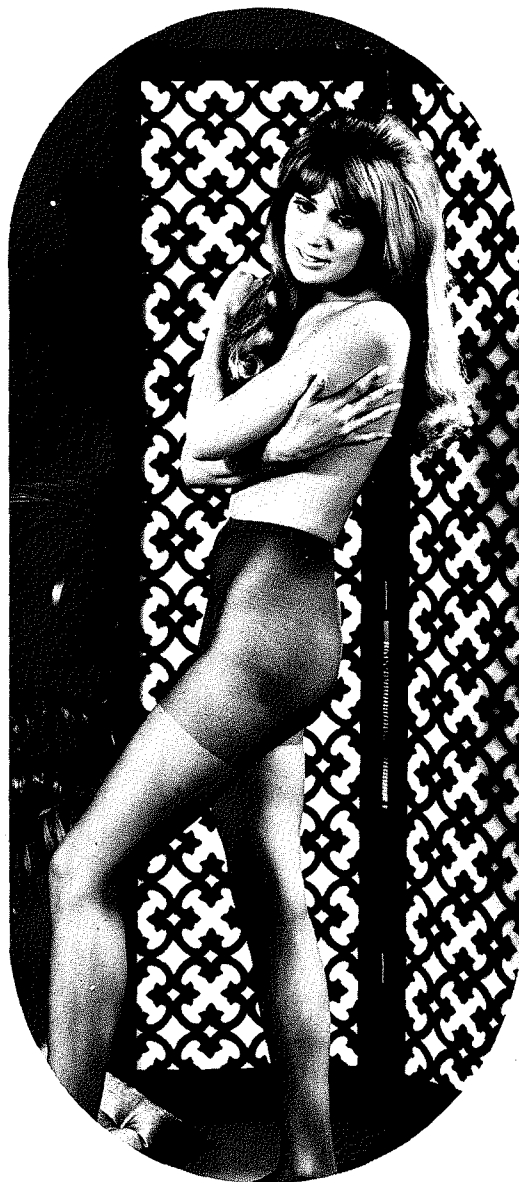

KNIFE GRINDER sharpens straight or angle type knives, is simple and easy to operate, eliminates defective garments caused by dull knives.

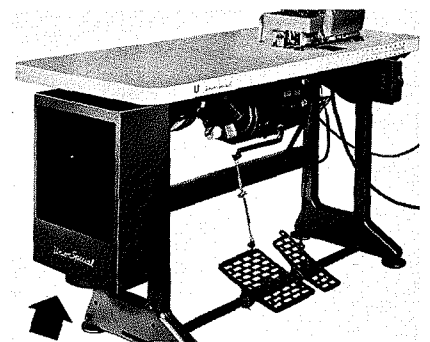

HEAT DISPELLER—Union Special's auxiliary unit (arrow) is an effective means for reducing oil temperature where heavy duty service requires it. Style 2899 E-1

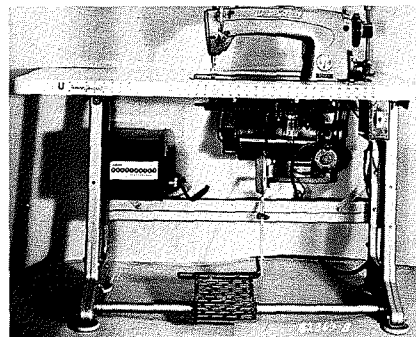

AMCO ELECTRONIC NEEDLE POSITIONERS eliminate the necessity of reaching for the hand-wheel to move the needle up or down . . . this allows the operator to keep both hands on the work, insuring better control, uniform quality and increased production.

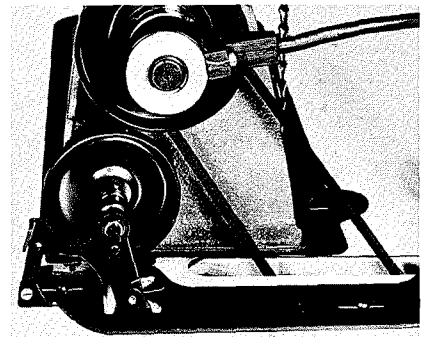

**UNION SPECIAL
CORPORATION**



Union Special[®]
INDUSTRIAL SEWING MACHINES

UNION SPECIAL maintains sales and service facilities throughout the world. These offices will aid you in the selection of the right sewing equipment for your particular operation. Union Special representatives and service men are factory trained and are able to serve your needs promptly and efficiently. Whatever your location, there is a Union Special Representative to serve you. Check with him today.

ATLANTA, GA.

BOSTON, MASS.

CHICAGO, ILL.

DALLAS, TEXAS

LOS ANGELES, CAL.

NEW YORK, N. Y.

PHILADELPHIA, PA.

MONTREAL, CANADA

TORONTO, CANADA

BRUSSELS, BELGIUM

LEICESTER, ENGLAND

LONDON, ENGLAND

PARIS, FRANCE

STUTT GART, GERMANY

Representatives and distributors in all important industrial cities throughout the world.

UNION SPECIAL CORPORATION
400 N. FRANKLIN ST., CHICAGO, ILL. 60610