

**FIRST
EDITION**

Union Special[®]
INDUSTRIAL SEWING EQUIPMENT

CATALOG NO. 111L

STYLES

52800BA	52800BR
52800BC	52800BS
52800 BD	52800BT
52800BE	52800BU
52800BF	52800 BV
52800BM	52800BW
52800BN	52800BX
52800BP	52800BY

**STREAMLINED
FIFTY THOUSAND SERIES**

Catalog No. 111 L

LIST OF PARTS

Styles

52800 BA	52800 BR
52800 BC	52800 BS
52800 BD	52800 BT
52800 BE	52800 BU
52800 BF	52800 BV
52800 BM	52800 BW
52800 BN	52800 BX
52800 BP	52800 BY

First Edition

Copyright 1961

By

Union Special Corporation
Rights Reserved in All Countries

UNION SPECIAL CORPORATION

INDUSTRIAL SEWING MACHINES

CHICAGO

Printed in U.S.A.

March, 1981

IDENTIFICATION OF MACHINES

Each UNION SPECIAL machine carries a Style number which is stamped in the name plate on the machine. Style numbers are classified as standard and special. Standard Style numbers have one or more letters suffixed, but never contain the letter "Z". Example: "Style 52800 BA". Special Style numbers contain the letter "Z". When only minor changes are made in a standard machine, a "Z" is suffixed to the standard Style number. Example: "52800 BAZ".

The over-all width of the stitch or the distance between the outside needles (extreme left and right) is represented by a gauge number. The actual spacing between the center lines of the outside needles, as applied to these machines, is as follows: No. 8 gauge, .125 inch, No. 10 gauge, .156 inch, No. 12 gauge, .172 inch, No. 14 gauge, .203 inch and No. 16 gauge, .234 inch.

APPLICATION OF CATALOG

This catalog applies specifically to the standard Styles of machines as listed herein. It can also be applied with discretion to some Special machines in this Class. References to direction such as right, left, front, back, etc., are given from the operator's position while seated at the machine. Operating direction of handwheel is toward the operator.

STYLES OF MACHINES

High Speed, Streamlined Flat Bed, Medium Throw Machines, Two and Three Needles Abreast, One Looper, Four and Five Thread Interlock Stitch, Light Weight Presser Bar and Needle Bar Driving Mechanism, Single Reservoir Enclosed Automatic Lubricating System, Filter Type Oil Return Pump and Oil Siphon Assembly, Oil Pan Base Plate, Lateral Looper Travel, Work Space to Right of Needle Bar 7 3/4 Inches.

- * 52800 BA Two needle four thread interlock machine, for attaching split tube borders to neck and armholes of knitted cotton and rayon athletic shirts, and for similar operations on light to medium weight material. For use with long length strips of light weight flat knit strip cut parallel with the wale. Wrench adjusted offset differential feed. Treadle operated intermittent strip tension, for releasing tension on armholes and straight sections of neck. Seam specification, 602-BSa-1. Type 121 GS needle. Standard gauge No. 8 only. Standard finished width 1/2 inch only.
- * 52800 BC Three needle five thread interlock machine, for attaching elastic waistband or leg bands to girdles. Wrench adjusted offset differential feed. Prepared for use with Galkin or Peerless undertrimmer. Adjustable elastic strip guide, tension assembly and tape reel for elastic. Seam specification, 605-LSa-3. Type 121 GBS needle. Standard gauge No. 16 only. Presser foot and differential feed dog not furnished.
- * 52800 BD Two needle four thread interlock machine, for attaching elastic waistband or leg bands to girdles. Wrench adjusted offset differential feed. Prepared for use with Galkin or Peerless undertrimmer. Adjustable elastic strip guide, tension assembly and tape reel for elastic. Seam specification, 602-LSa-2. Type 121 GBS needle. Standard gauge No. 12 only. Presser foot and differential feed dog not furnished.
- * 52800 BE Three needle five thread interlock machine, for joining main seams on girdles. Wrench adjusted tandem differential feed. Adjustable elastic strip guide, tension assembly and tape reel for elastic. Seam specification, 605-LSa-3. Type 121 GBS needle. Standard gauge No. 16 only.
- * 52800 BF Two needle four thread interlock machine, for attaching elastic waistband or leg bands to girdles. Wrench adjusted tandem differential feed. Adjustable elastic strip guide, tension assembly and tape reel for elastic. Seam specification, 602-LSa-2. Type 121 GBS needle, Standard gauge No. 12 only.
- * 52800 BM Three needle five thread interlock machine, for attaching cuffs in one operation to knitted undergarments, and for similar operations on medium to medium heavy weight material. Wrench adjusted offset differential feed. Seam specification, 605-LSa-1. Type 121 GBS needle. Standard gauge No. 16 only.

STYLES OF MACHINES (Continued)

- * 52800 BN Three needle five thread interlock machine, for single operation crotch seaming, and for similar operations on medium to medium heavy weight material. Wrench adjusted tandem differential feed. Seam specification, 605-FSa-1. Type 121 GBS needle. Standard gauge No. 16 only.
- * 52800 BP Two needle four thread interlock machine, for attaching split tube borders to neck and armholes of light weight knitted cotton and rayon athletic shirts, and for similar operations on light to medium weight material. For use with long length light weight flat knit strip cut parallel with the wale. Wrench adjusted offset differential feed. Treadle operated intermittent strip tension, for releasing tension on armholes and straight sections of neck. Seam specification, 602-BSa-1. Type 121 GS needle. Standard gauge No. 8 only. Standard finished widths 7/16, 1/2, 5/8 and 3/4 inch.
- * 52800 BR Same as 52800 BP, except it is equipped with treadle controlled intermittent differential feed and is not equipped with intermittent strip tension. Constant strip tension.
- * 52800 BS Two needle four thread interlock machine, for attaching split tube borders to men's, women's and children's knitted cotton, nylon and rayon underwear, Tee shirts, polo shirts, and for similar operations on light to medium weight material. For use with long length light weight flat knit strip cut parallel with the wale. Wrench adjusted offset differential feed. Constant strip tension. Seam specification, 602-BSa-1. Type 121 GS needle. Standard gauge No. 8 only. Standard finished widths 1/2, 5/8, 3/4, 7/8 and 1 inch.
- * 52800 BT Two needle four thread interlock machine, for attaching elastic and previously made lace to knitted undergarments, and for similar operations on light to medium weight material. Wrench adjusted tandem differential feed. Adjustable elastic strip guide and tension assembly. Seam specification, 602-FSa-1. Type 121 GS needle. Standard gauge Nos. 8, 10 and 12.
- * 52800 BU Two needle four thread interlock machine, for attaching collarettes to knitted undergarments, and for similar operations on light to medium weight material. For use with long length ribbed knit strip cut at right angle to the wale or parallel with the wale. Wrench adjusted offset differential feed. Constant strip tension. Seam specification, 602-BSa-1. Type 121 GS needle. Standard gauge Nos. 8 and 12. Standard finished widths 3/4, 7/8, 1 and 1 1/4 inches.
- * 52800 BV Two needle four thread interlock machine, for attaching collarettes to knitted undergarments, and for similar operations on light to medium weight material. For use with long length flat knit or ribbed knit strip cut at right angle to the wale or parallel with the wale. Wrench adjusted offset differential feed. Constant strip tension. Seam specification, 602-BSb-1. Type 121 GS needle. Standard gauge Nos. 8 and 12. Standard finished widths 1/2, 5/8, 3/4, 7/8, 1 and 1 1/4 inches.
- * 52800 BW Three needle five thread interlock machine, for attaching collarettes to knitted undergarments, and for similar operations on light to medium weight material. For use with long length ribbed knit strip cut at right angle to the wale or parallel with the wale. Wrench adjusted offset differential feed. Constant strip tension. Seam specification, 605-BSa-1. Type 121 GBS needle. Standard gauge Nos. 14 and 16. Standard finished widths 3/4, 7/8, 1 and 1 1/4 inches.
- * 52800 BX Three needle five thread interlock machine, for patch operations on flat and ribbed knit undergarments, and for similar operations on light to medium weight material. Wrench adjusted tandem differential feed. Seam specification, 605-SSa-1. Type 121 GBS needle. Standard gauge No. 16 only.
- * 52800 BY Same as 52800 BS, except no folder, folder clamp or edge guide furnished.
- * MACHINES DISCONTINUED In most instances, component parts can be ordered for customer repair.

NEEDLES

Each needle has a type number and size number. The type number denotes the kind of shank, point, length groove, finish and other details. The size number denotes the largest diameter of the blade, measured in thousandths of an inch, midway between the shank and the eye, and is stamped in the needle shank. Collectively, the type number and size number is the complete symbol.

NEEDLES (Continued)

To have orders promptly and accurately filled, forward the empty package, a sample needle, or the type and size number should be given. See description on packages. A complete order would read as follows: "1000 Needles, Type 121GS, Size 080/032".

The type numbers of the needles recommended for each style of machine covered by this catalog are given in the machine style description. Other needles are available, but the ones indicated are those recommended to produce the most satisfactory results. The type numbers of the recommended needles, together with their description, and the sizes available are listed below:

121 GS	Round shank, round point, short, double groove, struck groove, chromium plated - sizes 065/025, 070/027, 075/029, 080/032, 090/036, 100/040, 110/044, 125/049, 140/054.
121 GBS	Round shank, round point, short, single groove, struck groove, ball point chromium plated - sizes 065/025, 070/027, 075/029, 080/032, 090/036, 100/040.

Selection of the proper needle size should be determined by the size of thread used. Thread should pass freely through needle eye in order to produce a good stitch formation.

ORDERING REPAIR PARTS

ILLUSTRATIONS

This catalog has been arranged to simplify ordering repair parts. Exploded views of various sections of the mechanism are shown so that the parts may be seen in their actual position in the machine. On the page opposite the illustration will be found a listing of the parts with their part number, description and the number of pieces required in the particular view being shown.

The numbers in the first column are reference numbers only, and merely indicate the position of that part in the illustration. Reference numbers should never be used in ordering parts. Always use part number listed in the second column.

Component parts of sub-assemblies, which can be furnished for repairs, are indicated by indenting their descriptions under the description of the main sub-assembly. Example:

67	29476 LE	Looper Driving Lever Crank Assembly -----	1
68	22559 A	Screw, lower -----	2
69	51243 C	Ball Stud Guide-----	1
70	22729	Screw -----	1
71	22587	Screw, upper -----	2

It will be noted in the above example that the eccentric, ball stud and bearing are not listed. The reason is that replacement of these parts individually is not recommended, so the complete sub-assembly should be ordered.

In those cases where a part is common to all of the machines covered by this catalog, no specific usage will be mentioned in the description. However, when the parts for the various machines are not the same, the specific usage will be mentioned in the description, and, if necessary, the difference will be shown in the illustration.

At the back of the book will be found a numerical index of all the parts shown in this book. This will facilitate locating the illustration and description when only the part number is known.

IDENTIFYING PARTS

Where the construction permits, each part is stamped with its part number. On some of the smaller parts, and on those where construction does not permit, an identification letter is stamped in to distinguish the part from similar ones.

Part numbers represent the same part, regardless of catalog in which they appear.

IMPORTANT! ON ALL ORDERS, PLEASE INCLUDE PART NAME AND STYLE OF MACHINE FOR WHICH PART IS ORDERED.

USE GENUINE REPAIR PARTS

Success in the operation of these machines can be secured only with genuine UNION SPECIAL Repair Parts as furnished by the Union Special Corporation, its subsidiaries and authorized distributors. They are designed according to the most approved scientific principles, and are made with utmost precision. Maximum efficiency and durability are assured.

TERMS

Prices are net cash and subject to change without notice. All shipments are forwarded f.o.b. shipping point. Parcel Post shipments are insured unless otherwise directed. A charge is made to cover the postage and insurance.

OILING AND THREADING DIAGRAM

The oil has been drained from the machine before shipping, and the reservoir must be filled before beginning to operate. Use a straight mineral oil with a Saybolt viscosity of 90 to 125 seconds at 100° Fahrenheit.

Oil is filled at the spring cap "A" in the top cover, and the level is checked at the sight gauge "B" on the front of the machine. The oil level should be maintained between the red lines on the gauge. The capacity of the oil reservoir is 12 ounces.

The machine is automatically lubricated, and no oiling, other than keeping the main reservoir filled, is necessary.

When oil level rises above the line of gauge "C", and does not recede, this indicates the oil siphon tube is not functioning properly. Drain excess oil by removing plug screw "D".

A daily check before the morning start should be made, and oil added if required. Oil which has gone through the machine is filtered and pumped back into the main reservoir, making too frequent oilings unnecessary. Excessive oil in the main reservoir may be drained at the plug screw in the main frame directly under the hand-wheel.

On the next page is a picture showing the manner in which the 52800 Styles covered in this catalog are threaded. The three needle machines are threaded in substantially the same manner. The spreader and looper threading has been enlarged for clarity.

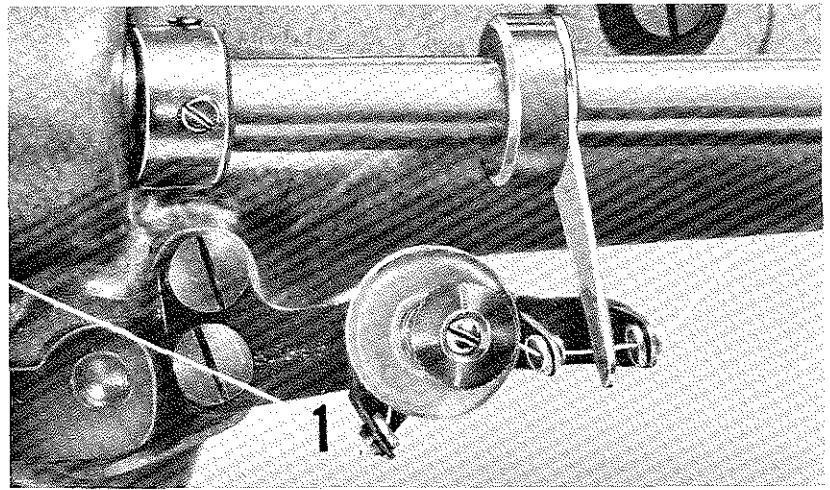
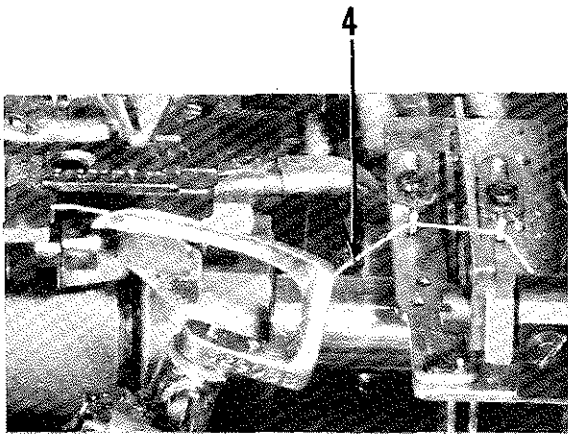
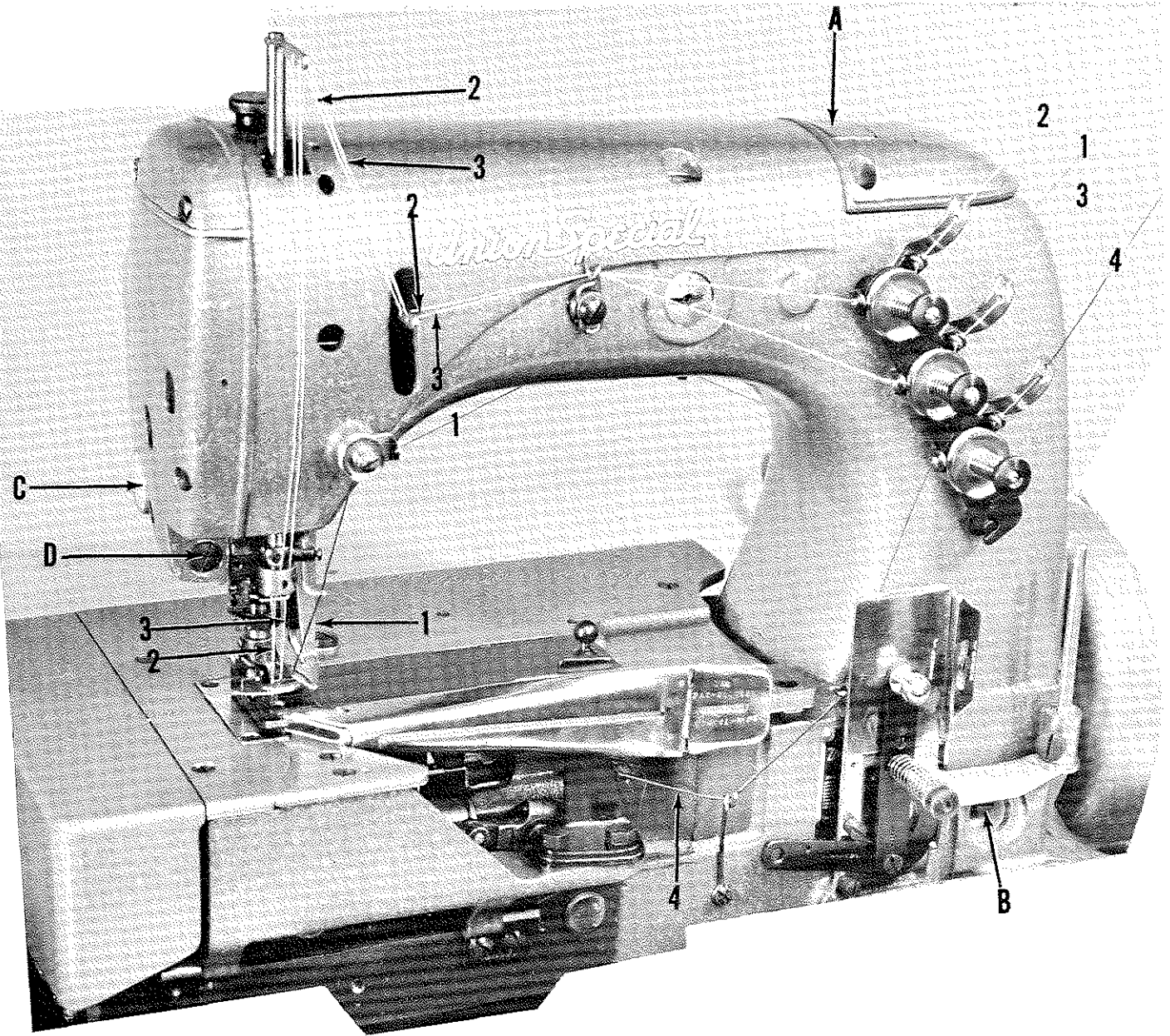

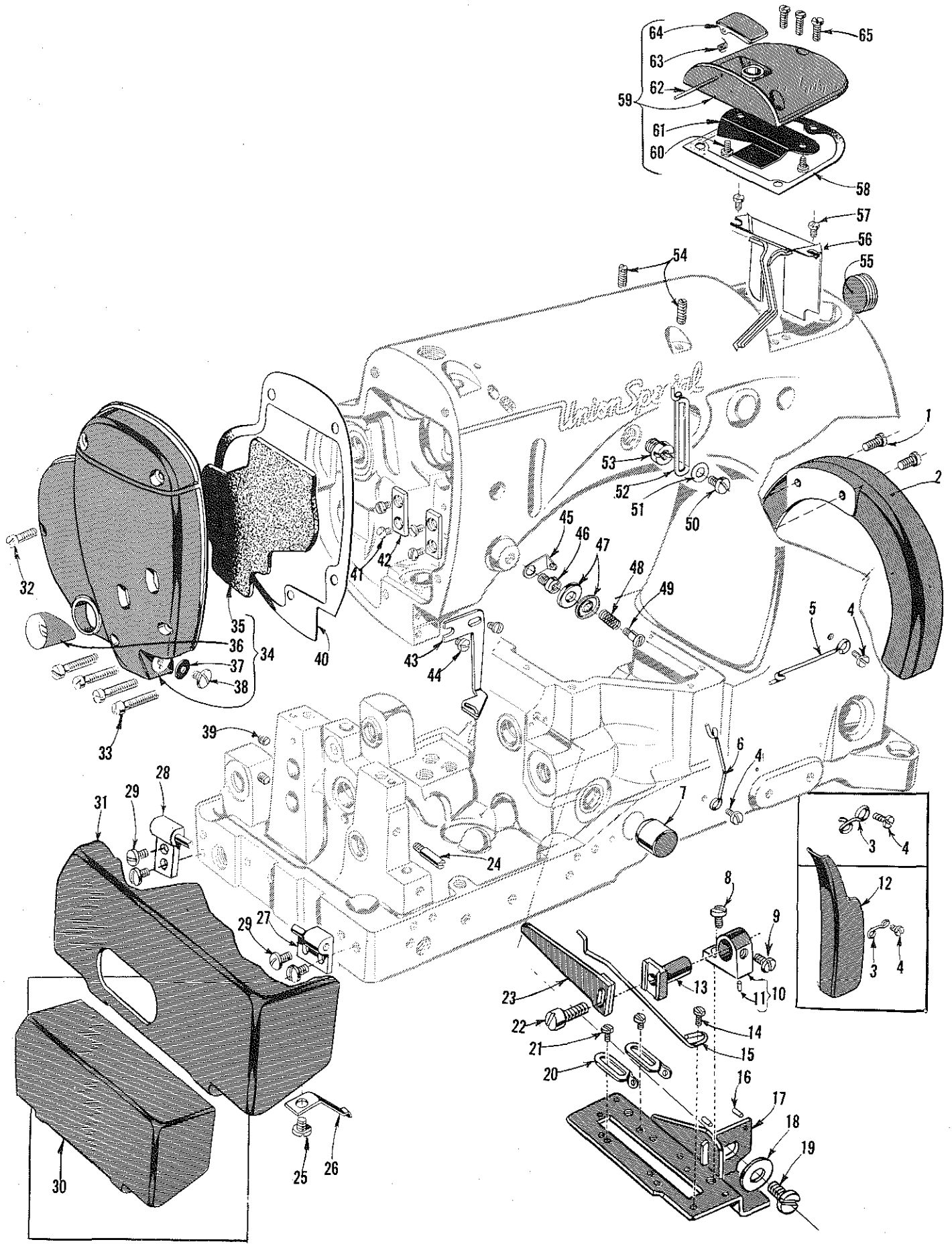

MAIN FRAME, CAST-OFF PLATE AND MISCELLANEOUS COVERS

Ref. No.	Part No.	Description	Amt. Req.
1	93	Screw -----	2
2	BB21375 AH	Belt Guard -----	1
3	52 A	Frame Thread Eyelet, for Styles 52800 BC, BD, BE, BF, BM, BN, BR, BS, BT, BU, BV, BW, BX, BY -----	1
4	98 A	Screw -----	2
5	52858	Frame Thread Eyelet, for Styles 52800 BA, BP -----	1
6	52958 B	Frame Thread Eyelet -----	1
7	52942 Y	Looper Drive Lever Shaft Synchronizing Stud -----	1
8	22768	Screw -----	1
9	87 U	Screw -----	1
10	52904 E	Cast-off and Retaining Finger Support Bracket -----	1
11	50-216 Blk.	Dowel Pin -----	1
12	51291 A	Looper Thread Guard, for Style 52800 BX -----	1
13	52804 E	Retainer Support -----	1
14	73 A	Screw -----	1
15	52904 G	Cast-off Wire -----	1
16	50-216 Blk.	Dowel Pin -----	2
17	52957 C	Cast-off Support Plate -----	1
18	21657 E	Washer -----	1
19	22528	Screw -----	1
20	52958 D	Looper Thread Take-up Eyelet -----	2
21	73 A	Screw -----	2
22	22516	Screw -----	1
23	52904 B	Retaining Finger -----	1
24	22799 M	Screw -----	1
25	22711	Screw -----	1
26	52885 L	End Cover Spring -----	1
27	57885	End Cover Hinge, front -----	1
28	57885 B	End Cover Hinge, rear -----	1
29	22848	Screw -----	4
30	52985	End Cover, for Styles 52800 BA, BC, BD, BE, BF, BM, BN, BP, BS, BT, BU, BV, BW, BX, BY -----	1
31	52985 A	End Cover, for Style 52800 BR -----	1
32	22572 A	Screw -----	1
33	294	Screw, for Styles 52800 BA, BM, BN, BP, BR, BS, BU, BV, BW, BX, BY -----	4
	294	Screw, for Styles 52800 BC, BD, BE, BF, BT -----	2
34	52882 R	Head Cover -----	1
35	52882 Z	Felt Liner -----	1
36	50-648 Blk.	Oil Gauge -----	1
37	52882 W	Gasket -----	1
38	22542	Screw -----	1
39	22597	Screw, for Style 52800 BR -----	2
40	52882 S	Gasket -----	1
41	22513	Screw -----	4
42	35731 A	Presser Bar Connection Guide Plate -----	2
43	52844 A	Thread Guide -----	1
44	90	Screw -----	2
45	35582 B	Thread Guide -----	1
46	22517 C	Supplementary Tension Screw, front -----	1
47	15438 B	Supplementary Tension Disc -----	2
48	15438 C	Supplementary Tension Spring, front -----	1
49	15438 D	Supplementary Tension Stud -----	1
50	22848	Screw -----	1
51	20	Washer -----	1
52	539	Frame Thread Eyelet -----	1
53	22889 A	Plug Screw -----	1
54	719	Screw -----	2
55	22539 D	Plug Screw -----	1
56	56382 AC	Needle Lever Bearing Oiler and Baffle Plate Assembly -----	1
57	90	Screw -----	2
58	52882 P	Gasket -----	1
59	52882 AD	Chamber Cover -----	1
60	90	Screw -----	2
61	52882 AA	Drip Plate -----	1
62	50-789 Blk.	Oil Cap Hinge Pin -----	1
63	52882 AC	Oil Cap Torsion Spring -----	1
64	39582 L	Oil Cap -----	1
65	22541 B	Screw -----	3

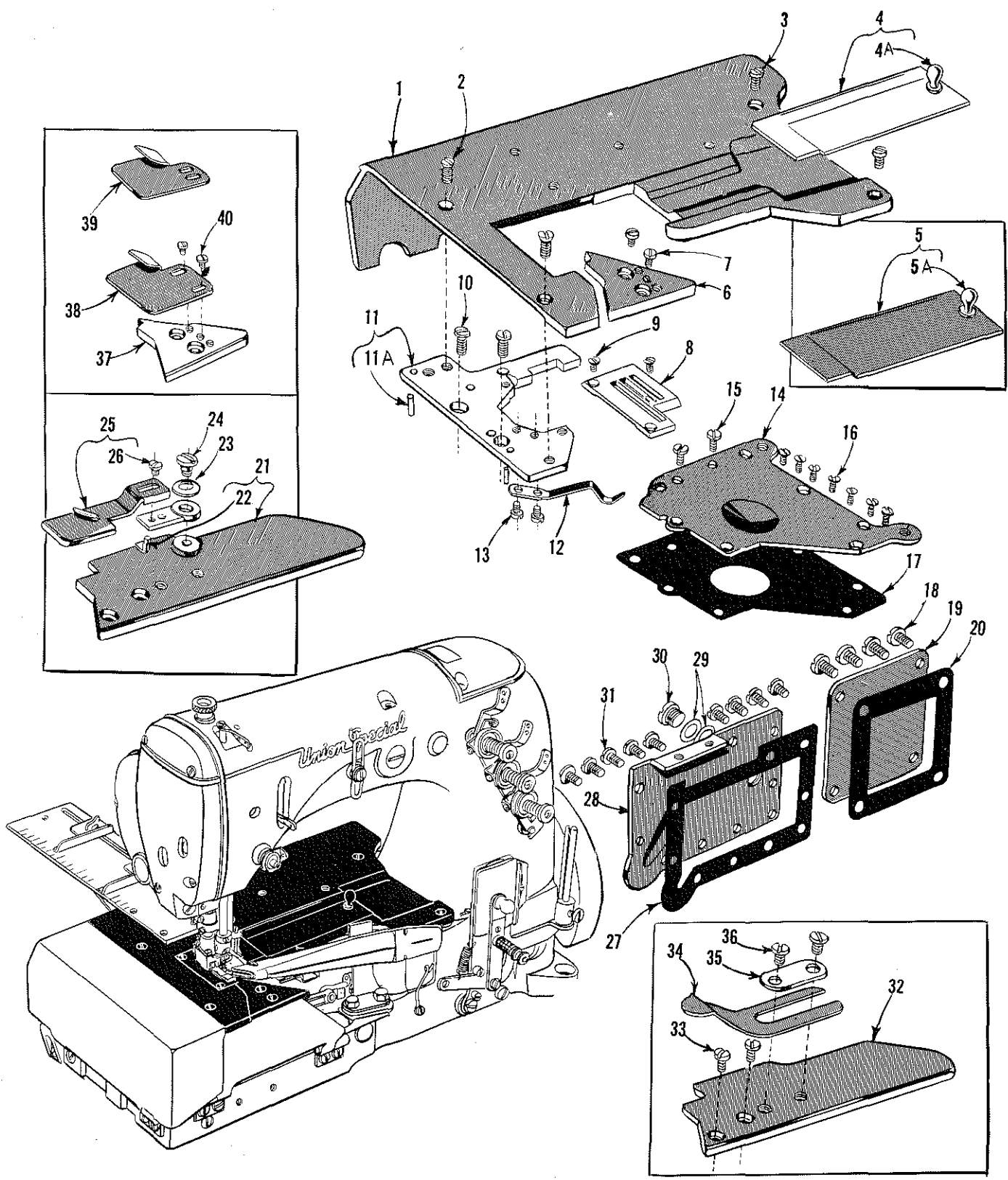

CLOTH PLATE, MISCELLANEOUS COVERS AND EDGE GUIDES

<u>Ref. No.</u>	<u>Part No.</u>	<u>Description</u>	<u>Amt. Req.</u>
1	52801 G	Cloth Plate -----	1
2	80	Screw -----	2
3	22839 C	Screw -----	2
4	52802 D	Cloth Plate Slide Cover, for Styles 52800 BA, BC, BD, BF, BP, BR, BS, BU, BV, BW, BY -----	1
4A	52978 V	Knob -----	1
5	52802 C	Cloth Plate Slide Cover, for Styles 52800 BE, BM, BN, BT, BX -----	1
5A	52978 V	Knob -----	1
6	52864 R	Folder Support Platform, for Styles 52800 BA, BP, BR, BS, BU, BV, BY -----	1
7	90	Screw -----	2
8		Throat Plate (See Pages 27, 29)-----	1
9	87	Screw -----	2
10	22839	Screw -----	2
11	52880	Throat Plate Support -----	1
11A	51280 J	Dowel Pin -----	2
12	43281 K	Hinge Bracket Spring -----	1
13	90	Screw -----	2
14	52982 F	Oil Reservoir Top Cover -----	1
15	22585 A	Screw -----	2
16	22524	Screw -----	7
17	51382 A	Gasket -----	1
18	22548	Screw -----	4
19	52882 AF	Crank Chamber Cover, lower -----	1
20	52882 U	Gasket -----	1
21	52864 U	Swinging Arm Platform, for Styles 52800 BF, BT -----	1
22	35772 D	Pin -----	1
23	12957 E	Spring Washer -----	1
24	22735	Screw -----	1
25	5003	Cloth Plate Gauge, for Styles 52800 BF, BT -----	1
26	357	Screw -----	1
27	52982 E	Gasket -----	1
28	52982 D	Oil Reservoir Back Cover -----	1
29	41394 A	Gasket -----	2
30	22733 B	Screw -----	1
31	22848	Screw -----	9
32	52864 T	Folder Support Swinging Arm Platform, for Styles 52800 BE, BM, BN, BX -----	1
33	93 A	Screw, for Styles 52800 BE, BF, BM, BN, BT, BX -----	2
34	10303 A	Cloth Plate Gauge, for Styles 52800 BE, BM -----	1
35	23425 V	Washer Plate -----	1
36	25 C	Screw -----	2
37	57764 A	Folder Support Platform, for Style 52800 BW -----	1
38	23133 M	Edge Guide, 5/64 inch capacity -----	1
39	23133 L	Edge Guide, 3/64 inch capacity, for Styles 52800 BS, BU, BV, BW -----	1
40	22561	Screw -----	2

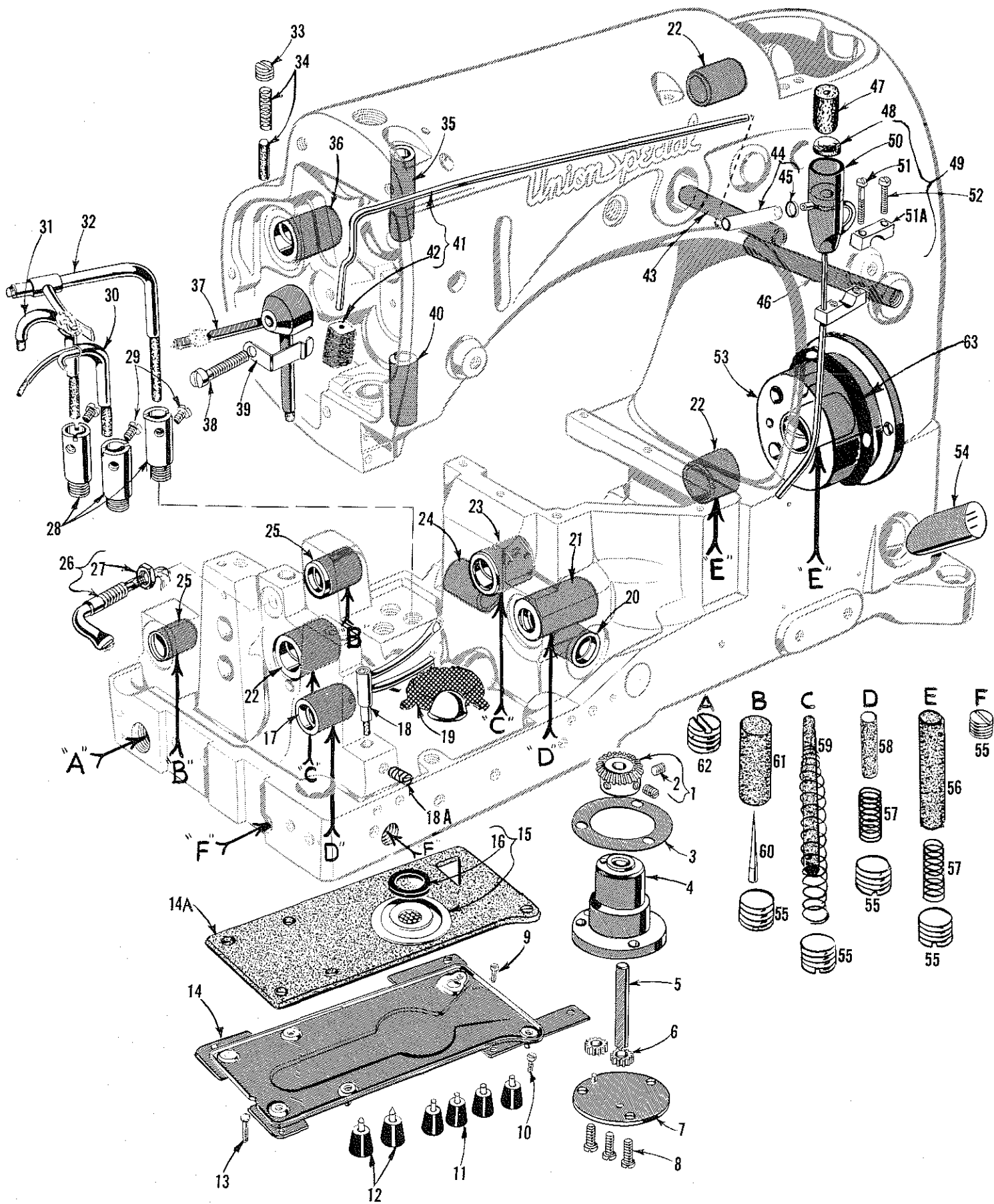

MAIN FRAME, BUSHINGS AND MISCELLANEOUS PARTS

Ref. No.	Part No.	Description	Amt. Req.
1	51493 BQ	Pump Driven Gear -----	1
2	531	Screw -----	2
3	643-127 Blk.	Gasket -----	1
4	51493 AG	Oil Pump Housing -----	1
5	51493 D	Oil Pump Driving Shaft -----	1
6	51493 E	Driving Shaft Gear -----	2
7	51493 AH	Oil Pump Housing Cover -----	1
8	22569 B	Screw -----	3
9	22645 H-64	Screw -----	1
10	22823 A	Screw -----	1
11	39595	Mounting Isolators -----	4
12	51295 B	Mounting Isolators -----	2
13	22823 B	Screw -----	1
14	51493 AZ	Oil Pan Base Plate -----	1
14A	51493 BG	Base Plate Oil Pad -----	1
15	51493 BH	Filter Cap Assembly -----	1
16	51493 BJ	Washer, sponge rubber -----	1
17	52944 T	Looper Rocker Shaft Bushing, left -----	1
18	52894 AK	Oil Tube, for looper rocker and left ball joint -----	1
18A	22560 B	Screw -----	1
19	51493, BK	Lint Filter Screen -----	1
20	52942 W	Looper Drive Lever Shaft Bushing, front -----	1
21	52944 U	Looper Rocker Shaft Bushing, right -----	1
22	52890 C	Main Shaft Bushing, left, inner right and Rocker Shaft Bushing, upper right -----	3
23	51290 T	Main Shaft Bushing, middle -----	1
24	57842 B	Looper Drive Lever Shaft Bushing, rear -----	1
25	52936	Feed Rocker Shaft Bushing, left and right -----	2
26	660-136	Oil Tube, for feed crank link -----	1
27	258 A	Nut -----	1
28	52894 AB	Oil Tube Holder -----	3
29	90	Screw -----	3
30	52794 G	Oil Tube, for feed, left and looper avoid eccentric -----	1
31	52894 AD	Oil Tube, for differential feed bar shaft -----	1
32	52894 AE	Oil Tube, for differential feed bar guide -----	1
33	22706 A	Plug Screw -----	1
34	666-99	Oil Wick, with spring, for spreader rocker shaft -----	1
35	51254 C	Needle Bar Bushing, upper -----	1
36	52890 C	Rocker Shaft Bushing, upper left -----	1
37	52894 K	Oil Tube Assembly -----	1
38	294	Screw -----	1
39	52994 V	Oil Siphon Clamp -----	1
40	51154 D	Needle Bar Bushing, lower -----	1
41	52994 U	Oil Siphon Tube -----	1
42	666-214	Felt Lint Filter -----	1
43	52883 R	Presser Foot Lifter Lever Bushing -----	1
44	51294 Y	Oil Tube Connection -----	1
45	21212	Oil Siphon Connection Locking Ring -----	2
46	21657 X	Tension Release Lever Shaft Bushing -----	1
47	666-201	Felt Plug -----	1
48	666-209	Siphon Cup Disc, felt -----	1
49	51294 U	Oil Siphon Assembly -----	1
50	643-263 Blk.	Siphon -----	1
51	22729 B	Screw -----	1
51A	51294 K	Clamp, upper -----	1
52	22729 A	Screw -----	1
53	52891 B	Crankshaft Bushing Housing, including bushing -----	1
54	50-648 Blk.	Lucite Oil Gauge -----	1
55	22571 A	Plug Screw -----	18
56	666-114	Oil Wick, for right main shaft bearing -----	2
57	35178 D	Spring -----	4
58	666-65	Oil Wick, for looper rocker shaft -----	2
59	666-118	Oil Wick, for left main shaft bearing -----	2
60	666-179	Wedge Pin -----	2
61	666-111	Oil Wick, for feed rocker shaft -----	2
62	22539 H	Plug Screw -----	1
63	56390 E	Crankshaft Bearing Housing Gasket -----	1

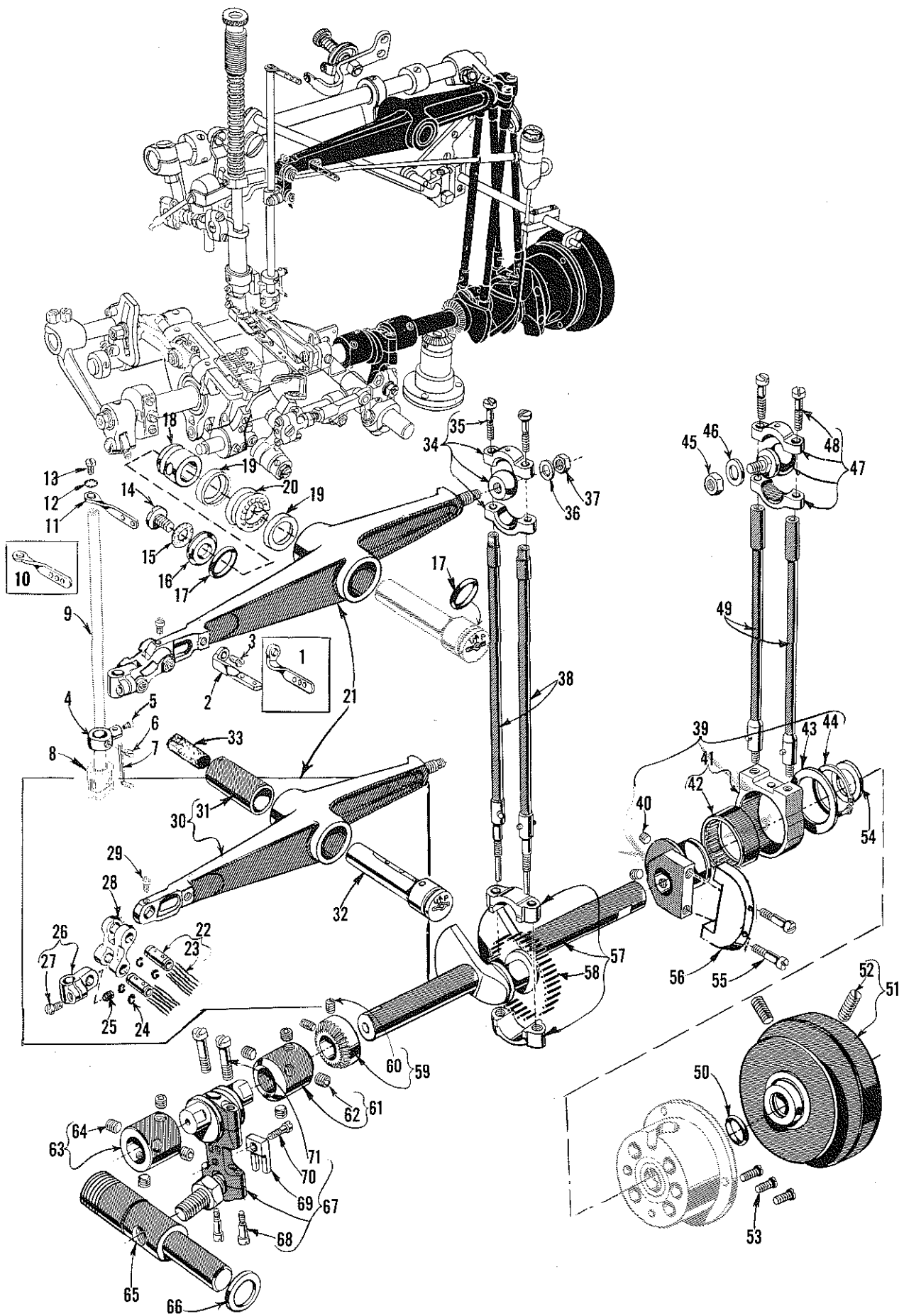

CRANKSHAFT, NEEDLE LEVER AND LOOPER DRIVING PARTS

Ref. No.	Part No.	Description	Amt. Req.
1	56958	Needle Lever Thread Eyelet, for Styles 52800 BC, BE, BM, BN, BW, BX-----	1
2	56458	Needle Lever Thread Eyelet, for Styles 52800 BA, BD, BF, BP, BR, BS, BT, BU, BV, BY -----	1
3	22768	Screw -----	1
4	52842 A	Needle Bar Finger Thread Eyelet Support -----	1
5	73 A	Screw -----	1
6	22743	Screw -----	1
7	41076 D	Thread Eyelet -----	1
8		Needle Bar Head (See Page 17) -----	1
9		Needle Bar (See Page 17) -----	1
10	56958 A	Needle Bar Thread Eyelet, for Styles 52800 BC, BE, BM, BN, BW, BX-----	1
11	56458 A	Needle Bar Thread Eyelet, for Styles 52800 BA, BD, BF, BP, BR, BS, BT, BU, BV, BY -----	1
12	27-435 Blk.	Washer -----	1
13	22768	Screw -----	1
14	22586 R	Screw -----	1
15	51250 F	Gasket-----	1
16	51250 D	Washer -----	1
17	660-212	Oil Seal Ring -----	2
18	56350 E	Needle Lever Thrust Collar -----	1
19	56350 F	Compression Cup-----	2
20	660-614	Temper Load Ring-----	1
21	29348 AF	Needle Lever Assembly -----	1
22	52336 A	Link Pin -----	2
23	WC-3	Columbia Yarn (6 strands) -----	-
24	660-215	Retaining Ring-----	4
25	22564	Screw -----	1
26	51254 K	Needle Bar Connection -----	1
27	22562 A	Screw -----	1
28	56354 D	Needle Bar Link -----	1
29	77	Screw -----	1
30	56315 A	Needle Lever -----	1
31	56350 G	Needle Lever Bushing -----	1
32	56350 D	Needle Lever Stud -----	1
*33	666-170	Oil Wick -----	1
34	29066 R	Needle Lever Connecting Rod and Upper Bearing Assembly -----	1
35	22559 G	Screw -----	2
36	51216 N	Washer -----	1
37	51216 P	Nut -----	1
38	51216 G	Needle Lever Connecting Rod -----	2
39	29126 CR	Spreader Drive Eccentric Assembly -----	1
40	95	Screw -----	2
41	52951 A	Connecting Rod Bearing -----	1
42	660-244	Needle Bearing -----	1
43	52951 B	Retaining Washing -----	1
44	660-246	Tru-Arc Ring -----	1
45	18	Nut -----	1
46	HA20 A	Washer -----	1
47	52952 B	Spreader Connecting Rod Ball Joint, upper -----	1
48	22559 G	Screw -----	2
49	52916	Spreader Driving Eccentric Connecting Rod -----	2
50	660-202	Oil Seal Ring -----	1
51	52921 B	Pulley -----	1
52	22894 G	Screw -----	2
53	22569 B	Screw -----	3
54	52951 C	Spacing Washer -----	1
55	22587 H	Screw -----	2
56	52947 A	Counterweight -----	1
57	29476 HL	Crankshaft Assembly, .910 inch throw -----	1
58	51216 M	Needle Bearing Rollers -----	28
59	51493 BP	Pump Driving Gear -----	1
60	22560 B	Screw -----	2
61	52943 L	Looper Drive Lever Crank and Crankshaft Connection -----	1
62	22894 X	Screw -----	4
63	56343 D	Looper Drive Lever Crank and Main Shaft Connection -----	1
64	22894 X	Screw -----	4
65	52942 A	Looper Drive Lever Rocker Shaft -----	1
66	52951 C	Spacing Washer -----	1
67	29476 LE	Looper Driving Lever Crank Assembly -----	1
68	22559 A	Screw, lower -----	2
69	51243 C	Ball Stud Guide -----	1
70	22729	Screw -----	1
71	22587	Screw, upper -----	2

* Used with needle lever stud No. 51250 E, in old machines.

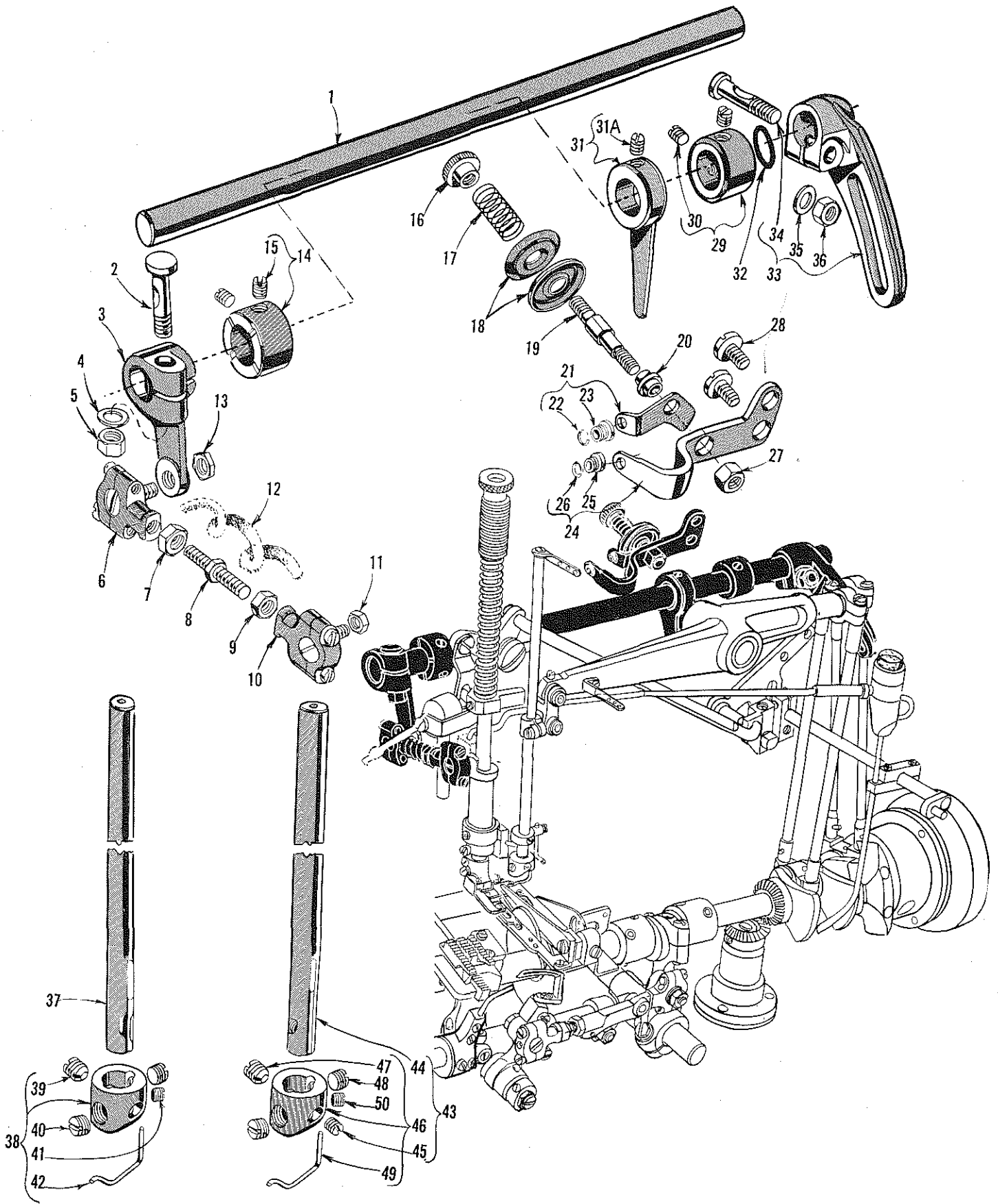

NEEDLE BARS AND SPREADER DRIVING MECHANISM

<u>Ref. No.</u>	<u>Part No.</u>	<u>Description</u>	<u>Amt. Req.</u>
1	52849	Spreader Rocker Shaft -----	1
2	55235 D	Screw -----	1
3	52849 B	Spreader Rocker Shaft Arm-----	1
4	6042 A	Washer-----	1
5	55235 E	Nut -----	1
6	52848 C	Spreader Connecting Rod Ball Joint, rear-----	1
7	269	Nut, left thread -----	1
8	51240 D	Spreader Connecting Rod -----	1
9	18	Nut, right thread -----	1
10	52848 B	Spreader Connecting Rod Ball Joint, front-----	1
11	12934 A	Nut -----	1
12	CL21	Oil Wick-----	1
13	15037 A	Nut -----	1
14	51147	Rocker Shaft Collar-----	1
15	95	Screw -----	2
16	51292 C	Tension Nut-----	1
17	51292 F-2	Tension Spring -----	1
18	109	Tension Disc-----	2
19	51292	Tension Post-----	1
20	51292 A	Tension Post Ferrule -----	1
21	51292 D	Tension Thread Eyelet -----	1
22	668-28	Eyelet Locking Ring -----	2
23	668-25	Eyelet-----	2
24	52855 A	Spreader Thread Pull-off Eyelet -----	1
25	668-25	Eyelet-----	1
26	668-28	Eyelet Locking Ring -----	1
27	43266	Nut -----	1
28	22872	Screw -----	2
29	52849 C	Spreader Rocker Shaft Oil Seal Collar -----	1
30	95	Screw -----	2
31	52855 G	Spreader Thread Pull-off Arm -----	1
31A	95	Screw -----	1
32	660-202	Oil Ring -----	1
33	52952 C	Spreader Thread Rock Shaft Lever -----	1
34	55235 D	Screw -----	1
35	6042 A	Washer-----	1
36	55235 E	Nut -----	1
37	52817 E-8	Needle Bar, for No. 8 gauge, 2 needle, on Styles 52800 BA, BP, BR, BS, BT, BU, BV, BY -----	1
	52817 E-10	Needle Bar, for No. 10 gauge, 2 needle, Style 52800 BT -----	1
	52717 E-12	Needle Bar, for No. 12 gauge, 2 needle, Style 52800 BD, BF, BT, BU, BV -----	1
	52817-14	Needle Bar, for No. 14 gauge, 3 needle, Style 52800 BW -----	1
38	52818-8	Needle Bar Head, for No. 8 gauge, Styles 52800 BA, BP, BR, BS, BT, BU, BV, BY-----	1
	52818-8	Needle Bar Head, for No. 10 gauge, Style 52800 BT -----	1
	52818-8	Needle Bar Head, for No. 12 gauge, Styles 52800 BD, BF, BT, BU, BV -----	1
	52818-8	Needle Bar Head, for No. 14 gauge, Style 52800 BW -----	1
39	89	Screw, spot-----	1
40	88 B	Screw, needle-----	2
41	28 B	Screw, thread guide wire-----	1
42	52842 G	Thread Guide Wire -----	1
43	29264 S-16	Needle Bar Assembly, for No. 16 gauge, 3 needle, Styles 52800 BC, BE, BM, BN, BW, BX-----	1
44	52817-16	Needle Bar, for No. 16 gauge, 3 needle, Styles 52800 BC, BE, BM, BN, BW, BX -----	1
45	28 C	Screw, middle needle -----	1
46	52818-8	Needle Bar Head -----	1
47	89	Screw, spot-----	1
48	88 B	Screw, needle-----	2
49	52842 G	Thread Guide Wire -----	1
50	28 B	Screw, thread guide wire-----	1

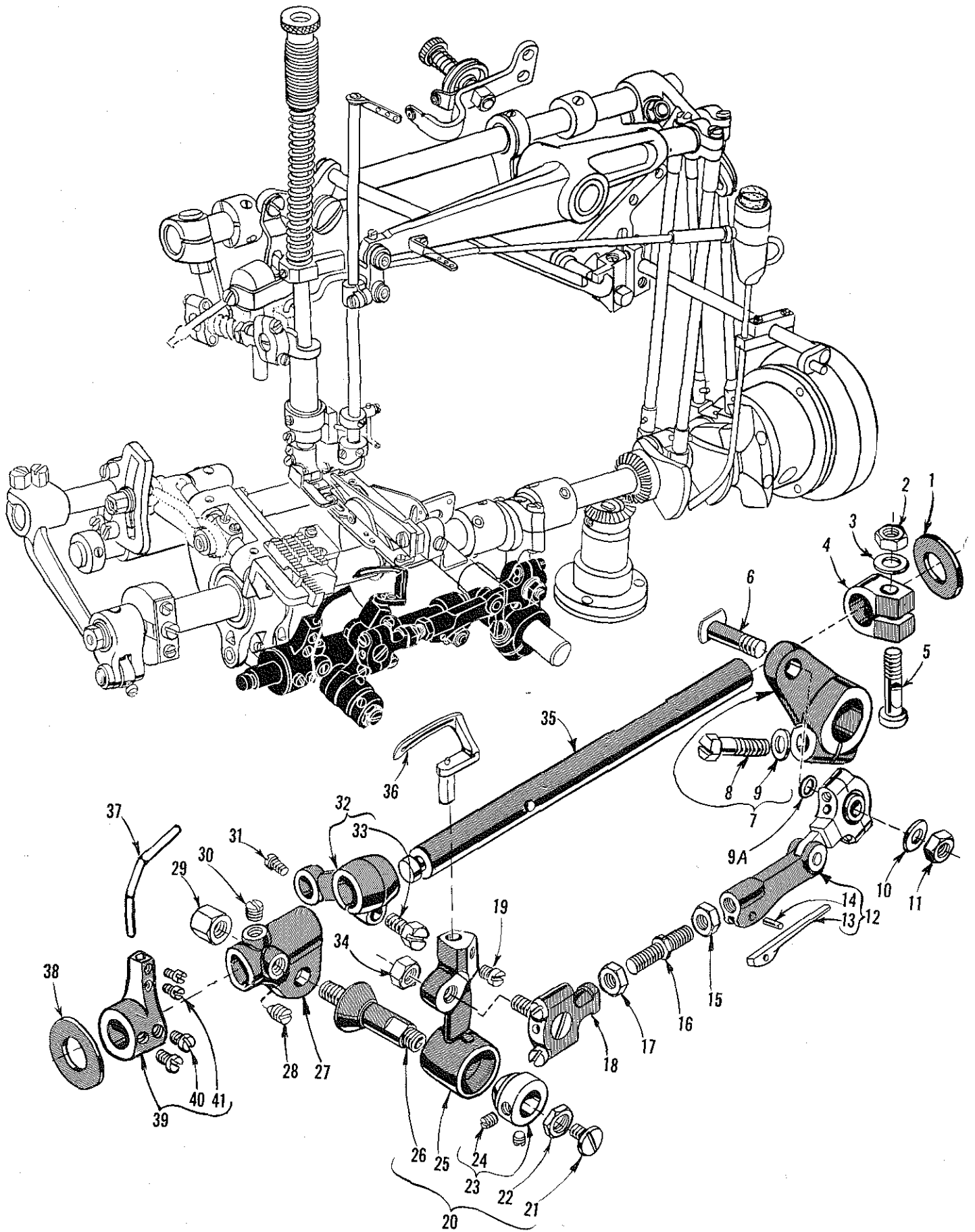

LOOPER ROCKER AND CONNECTING ROD PARTS

<u>Ref. No.</u>	<u>Part No.</u>	<u>Description</u>	<u>Amt. Req.</u>
1	51244 L	Thrust Washer-----	1
2	18	Nut-----	1
3	51216 N	Washer-----	1
4	51244 N	Looper Rocker Shaft Collar-----	1
5	55244 G	Looper Rocker Shaft Collar Stud-----	1
6	52942 R	Looper Drive Lever Stud-----	1
7	52942 P	Looper Drive Lever-----	1
8	22882 A	Screw-----	1
9	51242 M	Washer-----	1
9A	41355 U-4	Shim, .004 inch thick----- (as required)	
	41355 U-5	Shim, .005 inch thick----- (as required)	
	41355 U-6	Shim, .006 inch thick----- (as required)	
	41355 U-7	Shim, .007 inch thick----- (as required)	
	41355 U-8	Shim, .008 inch thick----- (as required)	
	41355 U-9	Shim, .009 inch thick----- (as required)	
10	20	Washer-----	1
11	18	Nut-----	1
12	29480 LY	Looper Connecting Rod Section and Ball Joint Assembly, right-----	1
13	56341 G	Spring-----	1
14	50-458 Blk.	Spring Pin-----	1
15	18	Nut, right thread-----	1
16	57840	Looper Connecting Rod-----	1
17	269	Nut, left thread-----	1
18	52841 A	Looper Connecting Rod Ball Joint, left-----	1
19	73	Looper Set Screw-----	1
20	29192 T	Looper Rocker Assembly-----	1
21	22829	Lock Nut Screw-----	1
22	258 A	Lock Nut-----	1
23	15465 F	Looper Rocker Cone-----	1
24	88	Set Screw-----	2
25	52813	Looper Rocker-----	1
26	51745	Looper Rocker Cone Stud-----	1
27	52444 B	Looper Rocker Frame-----	1
28	96	Spot Screw-----	1
29	51246	Looper Rocker Stud Nut-----	1
30	98	Set Screw-----	1
31	22768	Screw-----	1
32	51244 B	Thrust Rocker Shaft Arm-----	1
33	22519 H	Screw-----	1
34	18	Nut-----	1
35	51144	Looper Rocker Shaft-----	1
36	52708 BA	Looper, for all Styles except 52800 BF-----	1
	K70991	Looper, for Style 52800 BF-----	1
37	52825 C	Looper Needle Guard-----	1
38	51244 L	Thrust Washer-----	1
39	52825 D	Looper Needle Guard Holder-----	1
40	33174 B	Screw-----	2
41	22563	Screw-----	2

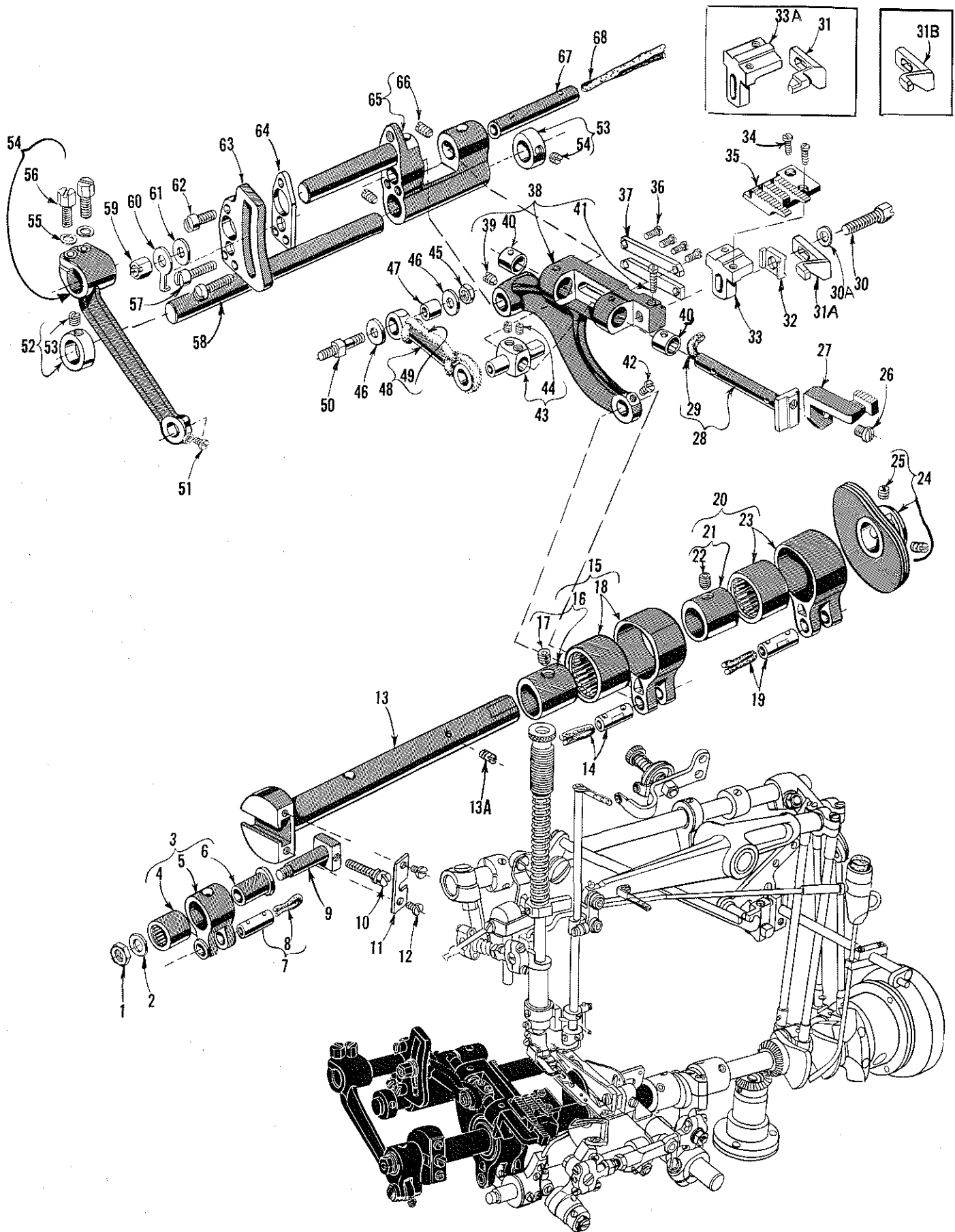

MAIN SHAFT, TAKE-UP AND DIFFERENTIAL FEED MECHANISM

<u>Ref. No.</u>	<u>Part No.</u>	<u>Description</u>	<u>Amt. Req.</u>
1	269	Nut, left thread -----	1
2	20	Washer -----	1
3	51236 E	Feed Crank Link Assembly -----	1
4	660-169	Needle Bearing -----	1
5	51236 D	Feed Crank Link -----	1
6	51236 F	Feed Crank Link Ferrule -----	1
7	51054	Feed Crank Link Pin -----	1
8	666-149	Oil Wick -----	1
9	51236 G	Feed Crank Stud -----	1
10	82	Stitch Regulating Screw -----	1
11	51236 B	Feed Crank Stud Cap -----	1
12	22768	Screw -----	2
13	52822 A	Main Shaft -----	1
13A	22801	Screw, for take-up -----	1
14	51236 A	Link Pin -----	1
15	29476 DX	Feed Lift Eccentric Assembly -----	1
16	51306	Feed Lift Eccentric, .072 inch throw -----	1
17	22894 D	Screw -----	1
18	51145 A	Eccentric Bearing -----	1
19	51236 A	Link Pin -----	1
20	29476 DX	Looper Avoid Eccentric Assembly -----	1
21	51306	Looper Avoid Eccentric, .072 inch throw -----	1
22	22894 D	Screw -----	1
23	51145 A	Eccentric Bearing -----	1
24	52923 D	Take-up -----	1
25	22580 D	Screw -----	2
26	90	Screw -----	1
27		Differential Feed Dog (See Pages 27, 29) -----	1
28	52834 H	Differential Feed Bar -----	1
29	CL21	Oil Wick -----	1
30	22519 J	Screw -----	1
30A	51235 G	Washer -----	1
31	52825 A	Rear Needle Guard, for 2 needle 12 gauge Styles 52800 BD, BF -----	1
	52825 E	Rear Needle Guard, for 3 needle 16 gauge Styles 52800 BC, BE -----	1
31A	52825 B	Rear Needle Guard, for 2 needle 8 gauge Style 52800 BP, 2 needle 10 or 12 gauge Styles 52800 BT, BU, BV and 3 needle 14 or 16 gauge Styles 52800 BM, BN, BW, BX -----	1
31B	52825 F	Rear Needle Guard, for 2 needle 8 gauge Styles 52800 BA, BR, BS, BT, BU, BV, BY -----	1
32	52925 D	Needle Guard Holder -----	1
33	52853	Feed Dog Holder, for all Styles except 52800 BC, BW -----	1
33A	52853 A	Feed Dog Holder, for Styles 52800 BC, BW -----	1
34	22593 A	Screw -----	2
35		Main Feed Dog (See Pages 27, 29) -----	1
36	22593	Screw -----	4
37	39237 D	Differential Feed Bar Guide Plate -----	2
38	52834	Main Feed Bar -----	1
39	22560 B	Screw -----	1
40	39237 G	Bushing -----	2
41	22747	Feed Dog Height Adjusting Screw -----	1
42	77	Screw -----	1
43	39237	Differential Feed Bar Guide -----	1
44	22565 C	Screw -----	2
45	907	Nut -----	1
46	51225 W	Differential Feed Bar Regulating Stud Washer -----	2
47	39236 V	Differential Feed Drive Link Bushing -----	1
48	52835 T	Differential Feed Bar Driving Link -----	1
49	CL21	Oil Wick -----	1
50	39236 B	Differential Feed Regulating Stud -----	1
51	77	Screw -----	1
52	482	Collar -----	2
53	98	Screw -----	2
54	52836 C	Feed Rocker Arm -----	1
55	51235 G	Washer -----	2
56	22519 C	Screw -----	2
57	75	Screw -----	2
58	8	Feed Rocker Shaft -----	1
59	52834 N	Differential Feed Regulating Stud Nut -----	1
60	39236 C	Regulating Stud Stop -----	1
61	51225 W	Washer -----	1
62	22516	Screw -----	1
63	52836 G	Feed Rocker Segment Plate -----	1
64	52836 N	Feed Rocker Segment Slot Plate Shim -----	1
65	52836	Feed Rocker -----	1
66	89	Screw -----	2
67	51134 C	Feed Bar Shaft -----	1
68		Wool Yarn -----	1

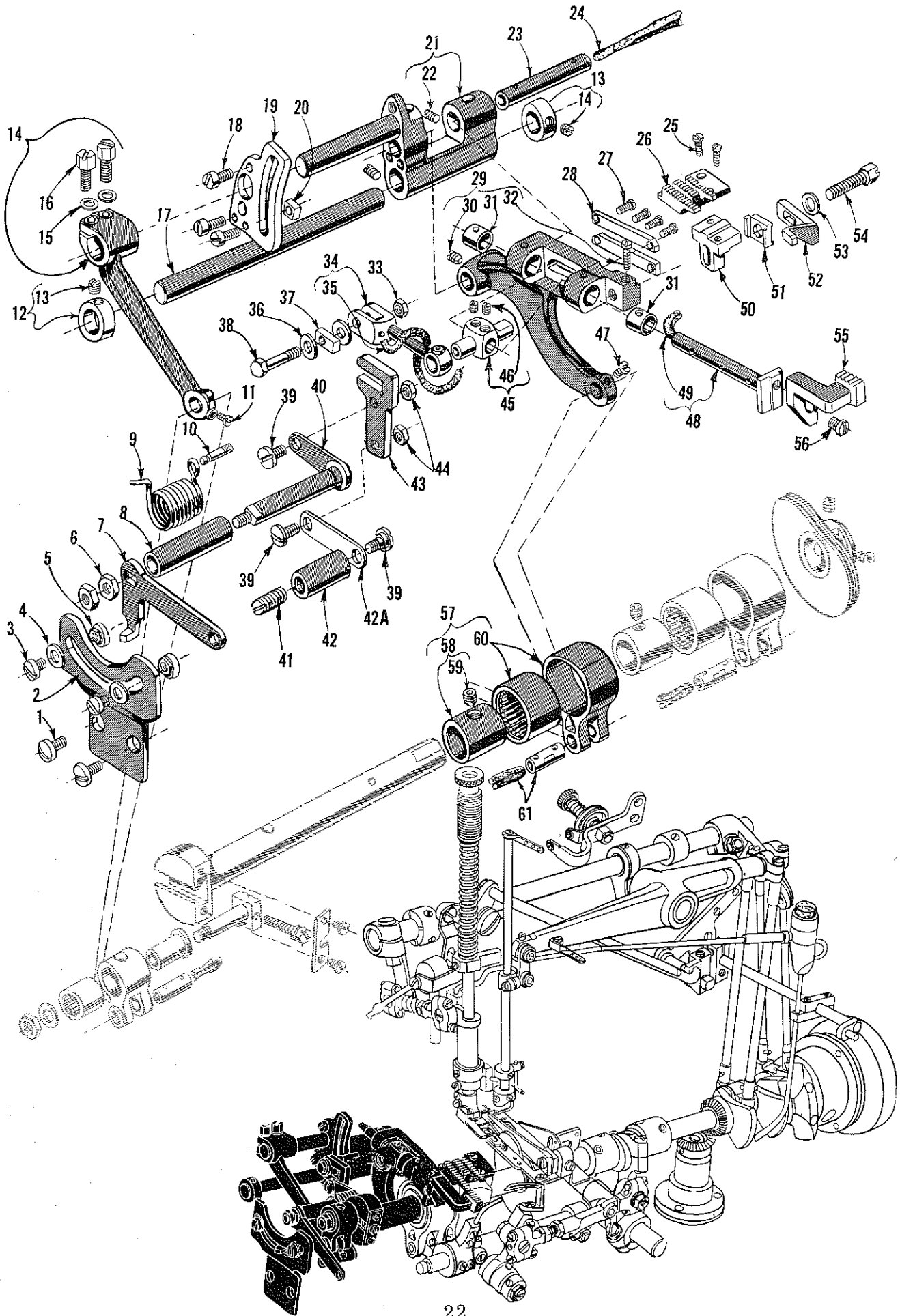

FOR STYLE 52800 BR ONLY

INTERMITTENT DIFFERENTIAL FEED MECHANISM

<u>Ref. No.</u>	<u>Part No.</u>	<u>Description</u>	<u>Amt. Req.</u>
1	22848	Screw -----	2
2	52835 N	Control Lever Stop Plate -----	1
3	25 CC	Screw -----	2
4	8372 A	Stop Washers -----	2
5	43139 A	Index Stop -----	2
6	9937	Nut -----	2
7	52835	Differential Feed Control Lever -----	1
8	51435 B	Control Lever Bushing -----	1
9	52835 K	Control Lever Spring -----	1
10	61267 G	Spring Pin -----	1
11	77	Screw -----	1
12	482	Collar -----	2
13	98	Screw -----	2
14	52836 C	Feed Rocker Arm -----	1
15	51235 G	Washer -----	2
16	22519 C	Screw -----	2
17	8	Feed Rocker Shaft -----	1
18	22516	Screw -----	3
19	52836 H	Feed Rocker Segment Plate -----	1
20	57836 F-40	Sliding Block, marked "N", .2540 inch wide -----	1
-	57836 F-45	Sliding Block, marked "P", .2545 inch wide -----	1
-	57836 F-50	Sliding Block, marked "R", .2550 inch wide -----	1
21	52836	Feed Rocker -----	1
22	89	Screw -----	2
23	51134 C	Feed Bar Shaft -----	1
24		Wool Yarn -----	1
25	22593	Screw -----	2
26		Main Feed Dog (See Pages 27, 29) -----	1
27	22593 A	Screw -----	4
28	39237 D	Differential Feed Bar Guide Plate -----	2
29	52834	Main Feed Bar -----	1
30	22560 B	Screw -----	1
31	39237 G	Bushing -----	2
32	22747	Feed Dog Height Adjusting Screw -----	1
33	907	Nut -----	1
34	52835 V	Differential Feed Bar Driving Link -----	1
35	CL21	Oil Wick -----	1
36	51225 W	Washer -----	2
37	52835 S	Differential Feed Fork Block -----	1
38	22868 A	Screw -----	1
39	22758 B	Screw -----	3
40	51435	Feed Control Lever, rear -----	1
41	719	Screw -----	1
42	52835 U	Pivot Stud Insert -----	1
42A	52835 G	Control Lever Link -----	1
43	52835 Q	Differential Feed Fork -----	1
44	12934 A	Nut -----	2
45	39237	Differential Feed Bar Guide -----	1
46	22565 C	Screw -----	2
47	77	Screw -----	1
48	52834 H	Differential Feed Bar -----	1
49	CL21	Oil Wick -----	1
50	52853	Feed Dog Holder -----	1
51	52925 D	Needle Guard Holder -----	1
52	52825 F	Rear Needle Guard, for 2 needle 8 gauge Styles 52800 BA, BR, BS, BT, BU, BV, BY -----	1
53	51235 G	Washer -----	1
54	22519 J	Screw -----	1
55		Differential Feed Dog (See Pages 27, 29) -----	1
56	90	Screw -----	1
57	29476 DV	Feed Lift Eccentric Assembly -----	1
58	51406	Feed Lift Eccentric, .062 inch throw -----	1
59	22894 D	Screw -----	1
60	51145 A	Eccentric Bearing -----	1
61	51236 A	Link Pin -----	1

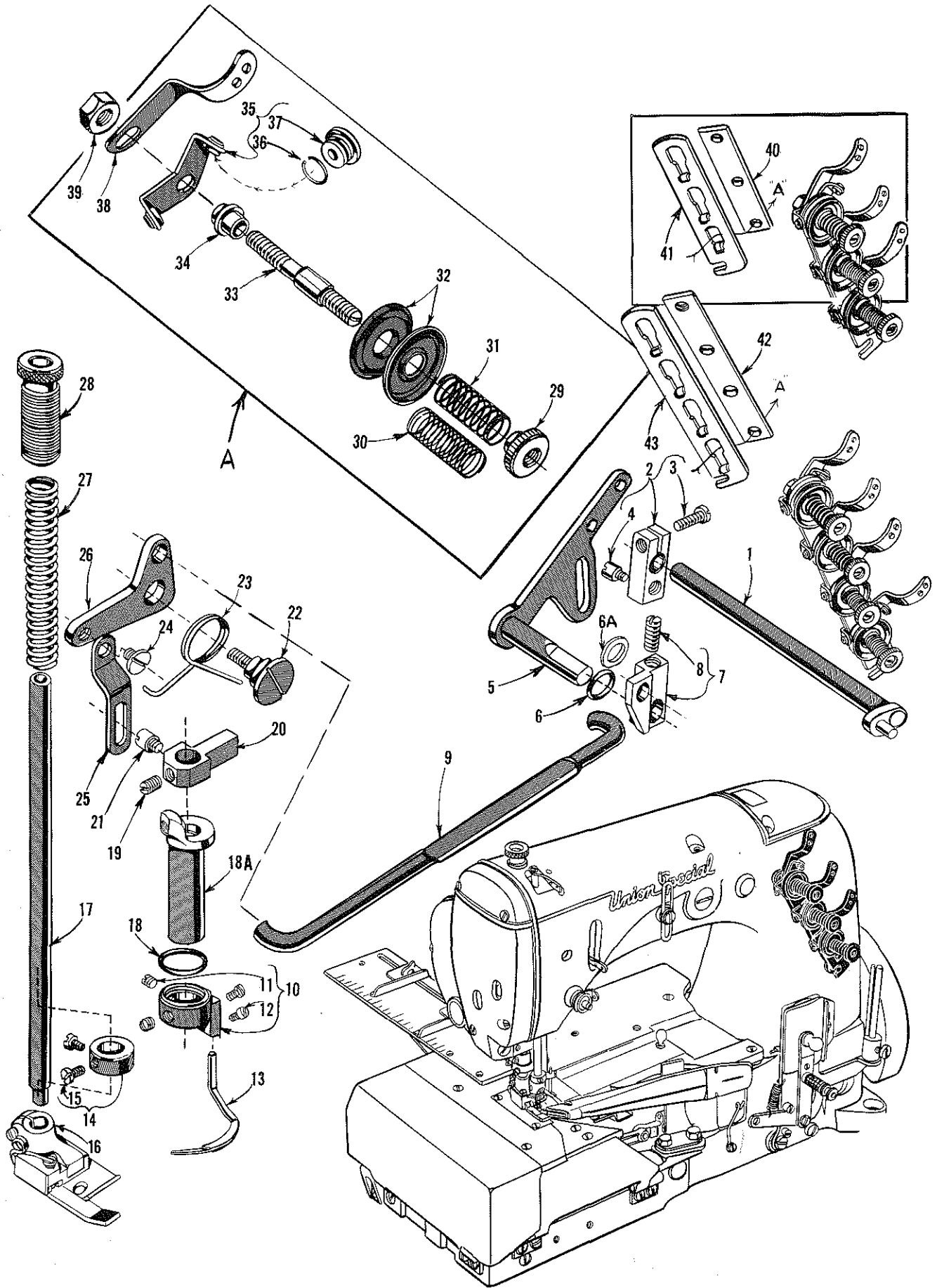

THREAD TENSION, LIFTER LEVER PARTS AND SPREADER HOLDING PARTS

Ref. No.	Part No.	Description	Amt. Req.
1	21657 W	Tension Release Lever Shaft -----	1
2	21657 Y	Tension Release Lever Connection -----	1
3	22596	Screw -----	1
4	402	Screw -----	1
5	51283 H	Presser Foot Lifter Lever -----	1
6	660-207	Oil Ring, for presser foot lifter lever -----	1
6A	39552 C	Washer -----	1
7	53783 N	Presser Foot Lifter Lever, internal-----	1
8	22537	Screw -----	1
9	56383 AB	Presser Foot Lifter Lever Connecting Rod-----	1
10	52846 A	Spreader Holder -----	1
11	88	Screw -----	2
12	77 A	Screw -----	2
13	52945 M	Spreader -----	1
14	52888 B	Presser Bar Stop Collar -----	1
15	22562	Screw -----	2
16		Presser Foot (See Pages 27, 29) -----	1
17	53688	Presser Bar -----	1
18	660-202	Oil Ring -----	1
18A	52847	Spreader Holder Carrier and Lower Presser Bar Bushing -----	1
19	531	Screw -----	1
20	51257 M	Presser Bar Connection and Guide -----	1
21	402	Screw -----	1
22	22557 B	Screw -----	1
23	52883 S	Presser Foot Lifter Lever Bell Crank Spring-----	1
24	22758 C	Screw -----	1
25	53783 A	Lifter Lever Link -----	1
26	53783 L	Presser Foot Lifter Lever Bell Crank -----	1
27	51256 C	Presser Bar Spring-----	1
28	52889 A	Presser Spring Regulator -----	1
29	51292 C	Tension Nut, for Styles 52800 BA, BD, BF, BP, BR, BS, BT, BU, BV, BY -----	3
	51292 C	Tension Nut, for Styles 52800 BC, BE, BM, BN, BW, BX -----	4
30	51292 F-1	Tension Spring, looper -----	1
31	51292 F-5	Tension Spring, needle, for Styles 52800 BA, BP, BR, BT -----	2
	51292 F-5	Tension Spring, needle, for Styles 52800 BC, BE, BM, BN, BW, BX-----	3
	51292 F-8	Tension Spring, needle, for Styles 52800 BD, BF, BS, BU, BV, BY --	2
32	109	Tension Disc, for Styles 52800 BA, BD, BF, BP, BR, BS, BT, BU, BV, BY -----	6
	109	Tension Disc, for Styles 52800 BC, BE, BM, BN, BW, BX -----	8
33	51292 G	Tension Post, for Styles 52800 BA, BD, BF, BP, BR, BS, BT, BU, BV, BY -----	3
	51292 G	Tension Post, for Styles 52800 BC, BE, BM, BN, BW, BX -----	4
34	51292 A	Tension Post Ferrule, for Styles 52800 BA, BD, BF, BP, BR, BS, BT, BU, BV, BY -----	3
	51292 A	Tension Post Ferrule, for Styles 52800 BC, BE, BM, BN, BW, BX --	4
35	51292 D	Tension Thread Eyelet, for Styles 52800 BA, BD, BF, BP, BR, BS, BT, BU, BV, BY -----	3
	51292 D	Tension Thread Eyelet, for Styles 52800 BC, BE, BM, BN, BW, BX -----	4
36	668-28	Locking Ring-----	6-8
37	668-25	Eyelet Insert-----	6-8
38	51491 C	Thread Lead-in Guide, for Styles 52800 BA, BD, BF, BP, BR, BS, BT, BU, BV, BY -----	3
	51491 C	Thread Lead-in Guide, for Styles 52800 BC, BE, BM, BN, BW, BX--	4
39	43266	Nut, for Styles 52800 BA, BD, BF, BP, BR, BS, BT, BU, BV, BY ----	1
	43266	Nut, for Styles 52800 BC, BE, BM, BN, BW, BX -----	2
40	52892	Tension Post Support, for Styles 52800 BA, BD, BF, BP, BR, BS, BT, BU, BV, BY -----	1
41	21657-3	Tension Dis Separator, for Styles 52800 BA, BD, BF, BP, BR, BS, BT, BU, BV, BY -----	1
42	56382 X	Tension Post Support, for Styles 52800 BC, BE, BM, BN, BW, BX --	1
43	21657-4	Tension Disc Separator, for Styles 52800 BC, BE, BM, BN, BW, BX -----	1

FEED DOGS, THROAT PLATES, PRESSER FEET

<u>Ref. No.</u>	<u>Part No.</u>	<u>Description</u>	<u>Amt. Req.</u>
1	57726	Differential Feed, for Styles 52800 BA, BP, BR, BS, BU, BV, BY-----	1
2	57705 A	Main Feed Dog, for Styles 52800 BA, BD, BP, BR, BS, BU, BV, BY-----	1
3	57824 A-8	Throat Plate, for No. 8 gauge, Styles 52800 BA, BP, BR, BS, BU BV, BY-----	1
4	13120 F-8	Presser Foot, for No. 8 gauge, Styles 52800 BA, BD, BP, BR, BS, BY----	1
5	13130 B	Presser Foot Shank-----	1
6	91	Screw-----	1
7	73 A	Screw-----	1
8	605	Screw-----	1
9	11534	Spring-----	1
10	13130 A	Yielding Section-----	1
11	13130 F-8	Presser Foot Bottom-----	1
12	22799 B	Hinge Screw-----	1
13	52820 H-8	Presser Foot, for No. 8 gauge, Styles 52800 BU, BV-----	1
14	13130 B	Presser Foot Shank-----	1
15	91	Screw-----	1
16	73 A	Screw-----	1
17	605	Screw-----	1
18	11534	Spring-----	1
19	52830 C	Yielding Section-----	1
20	52830 D	Adjustable Guide-----	1
21	22561	Screw-----	1
22	52830 H-8	Presser Foot Bottom-----	1
23	22799 B	Hinge Screw-----	1
24	52824 F-12	Throat Plate, for No. 12 gauge, Styles 52800 BU, BV-----	1
	52828 F-12	Throat Plate, for No. 12 gauge 16 to 20 S.P.I., Style 52800 BD-----	1
25	52820 H-12	Presser Foot, for No. 12 gauge, Styles 52800 BU, BV-----	1
	52820 M-12	Presser Foot, for No. 12 gauge, Style 52800 BF-----	1
26	13130 B	Presser Foot Shank-----	1
27	91	Screw-----	1
28	73 A	Screw-----	1
29	605	Screw-----	1
30	11534	Spring-----	1
31	52830 C	Yielding Section, for No. 52820 H-12-----	1
	52830 N	Yielding Section, for No. 52820 M-12-----	1
32	52830 D	Adjustable Guide, for No. 52820 H-12-----	1
33	22561	Screw, for No. 52820 H-12-----	1
34	52830 H-12	Presser Foot Bottom, for No. 52820 H-12-----	1
	52830 M-12	Presser Foot Bottom, for No. 52820 M-12-----	1
35	22799 B	Hinge Screw-----	1
36	52826 K	Differential Feed Dog, for Style 52800 BW-----	1
37	52805 K	Main Feed Dog, for Styles 52800 BC, BW-----	1
38	52824 K-14	Throat Plate, for No. 14 gauge, 9 to 12 S.P.I., Style 52800 BW-----	1
	52828 K-14	Throat Plate, for No. 14 gauge, 13 to 16 S.P.I., Style 52800 BW-----	1
39	52820 K-14	Presser Foot, for No. 14 gauge, Style 52800 BW-----	1
40	13130 B	Presser Foot Shank-----	1
41	91	Screw-----	1
42	73 A	Screw-----	1
43	605	Screw-----	1
44	11534	Spring-----	1
45	13130 A	Yielding Section-----	1
46	52830 K-14	Presser Foot Bottom-----	1
47	22799 B	Hinge Screw-----	1
48	52824 K-16	Throat Plate, for No. 16 gauge, 9 to 12 S.P.I., Style 52800 BW-----	1
	52828 K-16	Throat Plate, for No. 16 gauge, 13 to 16 S.P.I., Style 52800 BW-----	1
	52828 K-16	Throat Plate, for No. 16 gauge, 16 to 20 S.P.I., Style 52800 BC-----	1
49	52820 K-16	Presser Foot, for No. 16 gauge, Style 52800 BW-----	1
50	13130 B	Presser Foot Shank-----	1
51	91	Screw-----	1
52	73 A	Screw-----	1
53	605	Screw-----	1
54	11534	Spring-----	1
55	13130 A	Yielding Section-----	1
56	52830 K-16	Presser Foot Bottom-----	1
57	22799 B	Hinge Screw-----	1

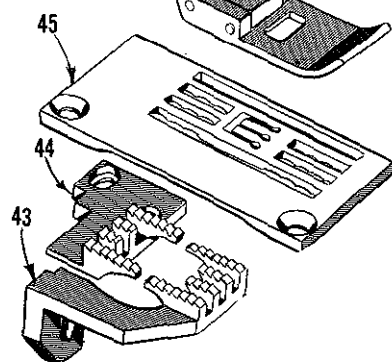
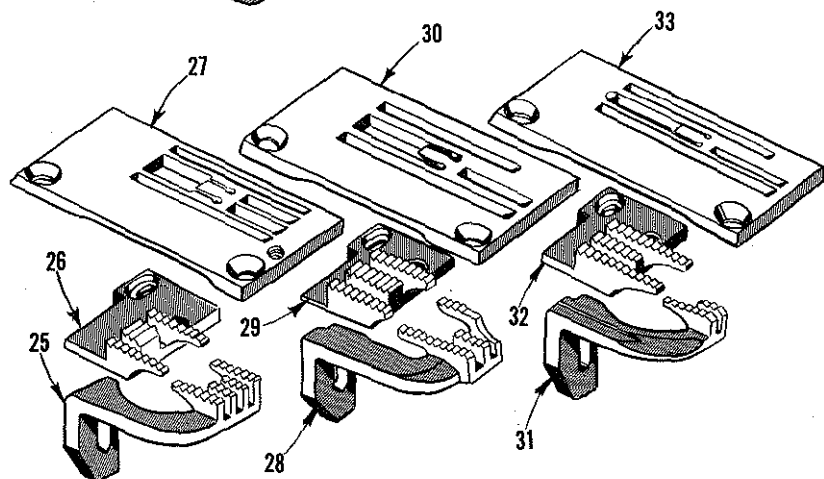
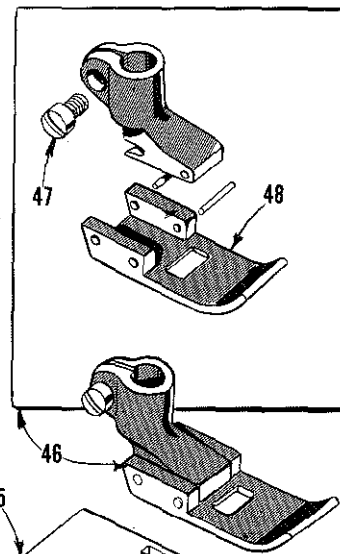
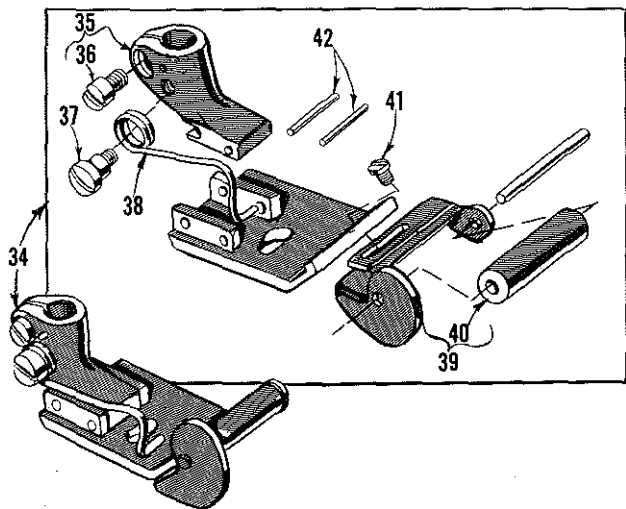
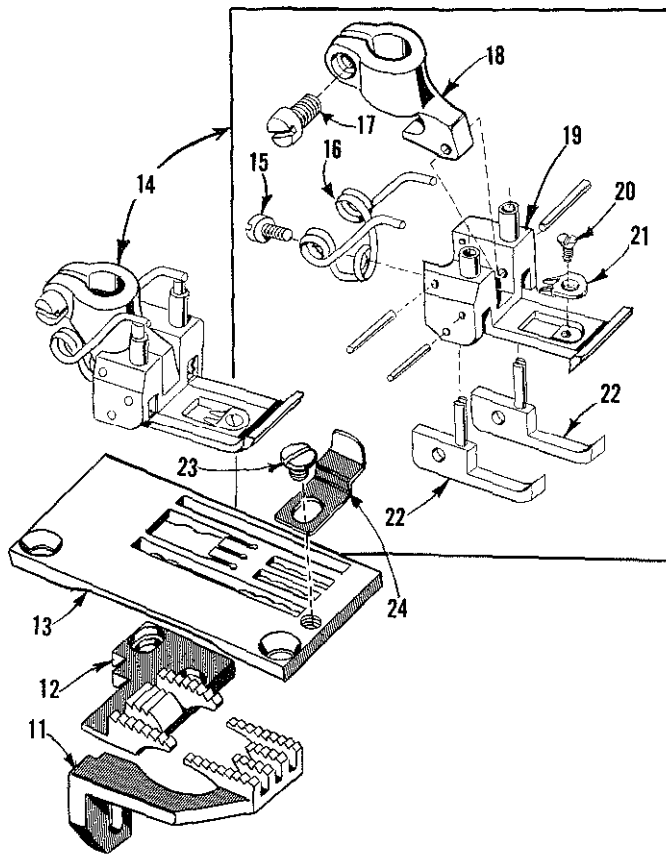
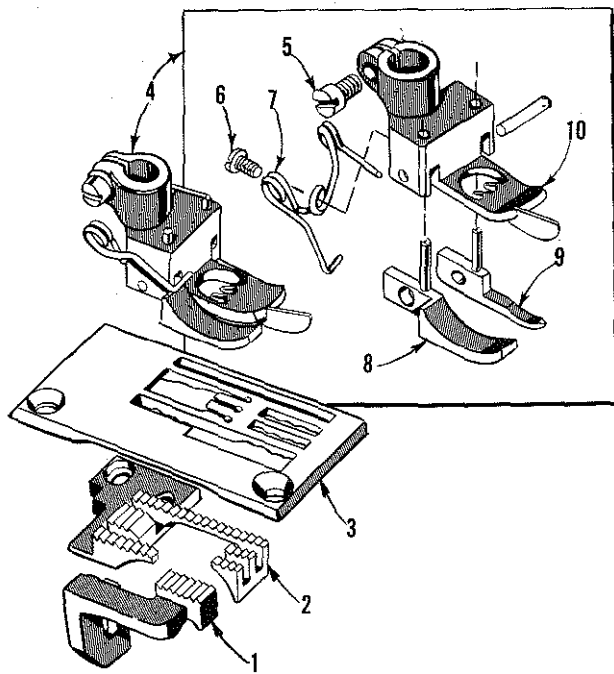

FEED DOGS, THROAT PLATES, PRESSER FEET

<u>Ref. No.</u>	<u>Part No.</u>	<u>Description</u>	<u>Amt. Req.</u>
1	5126 B	Differential Feed Dog, for Style 52800 BM -----	1
2	52805 B	Main Feed Dog, for Style 52800 BM -----	1
3	52824 B-16	Throat Plate, for No. 16 gauge, Style 52800 BM -----	1
4	5127 C	Presser Foot, for Styles 52800 BE, BM -----	1
5	91	Screw -----	1
6	605	Screw -----	1
7	5140	Spring-----	1
8	5141	Yielding Section, left -----	1
9	5041	Yielding Section, right -----	1
10	5141 A	Presser Foot Bottom -----	1
11	3026 A	Differential Feed Dog, for Styles 52800 BE, BN -----	1
12	52805 D-16	Main Feed Dog, for Styles 52800 BE, BN -----	1
13	52824 D-16	Throat Plate, for No. 16 gauge, 12 to 15 S. P. I., Style 52800 BN-----	1
	52828 D-16	Throat Plate, for No. 16 gauge, 16 to 18 S. P. I., Style 52800 BN-----	1
	52828 D-16	Throat Plate, for No. 16 gauge, 16 to 20 S. P. I., Style 52800 BE-----	1
14	G52827-16	Presser Foot, for Style 52800 BN -----	1
15	605	Screw -----	1
16	79633	Spring-----	1
17	91	Screw -----	1
18	G65-134	Presser Foot Shank-----	1
19	G52827-1	Presser Foot Bottom -----	1
20	22716 A	Screw -----	1
21	G52897 A-16	Stitch Tongue -----	1
22	G52827-2	Yielding Section -----	2
23	187 A	Screw, for Style 52800 BN-----	1
24	23195	Guide, for Style 52800 BN-----	1
25	5126	Differential Feed Dog, for No. 12 gauge, Styles 52800 BF, BT-----	1
26	5105 B	Main Feed Dog, for No. 12 gauge, Style 52800 BT -----	1
	52805 M-12	Main Feed Dog, for No. 12 gauge, Style 52800 BF -----	1
27	5024 B-12	Throat Plate, for No. 12 gauge, Style 52800 BT -----	1
	52824 M-12	Throat Plate, for No. 12 gauge, Style 52800 BF -----	1
28	52826	Differential Feed Dog, for No. 10 gauge, Style 52800 BT	1
29	13105 B	Main Feed Dog, for No. 10 gauge, Style 52800 BT -----	1
30	13124 B-10	Throat Plate, for No. 10 gauge, Style 52800 BT -----	1
31	52826 G	Differential Feed Dog, for No. 8 gauge, Style 52800 BT -	1
32	5005 R	Main Feed Dog, for No. 8 gauge, Style 52800 BT -----	1
33	5024 M-8	Throat Plate for No. 8 gauge, Style 52800 BT -----	1
34	52820 T-12	Presser Foot, for Style 52800 BT -----	1
35	52730	Presser Foot Shank-----	1
36	91	Screw -----	1
37	57 WD	Screw -----	1
38	52830 G	Spring-----	1
39	52730 A	Roller Guide, adjustable -----	1
40	52730 C	Roller-----	1
41	604	Screw -----	1
42	52730 X-578	Hinge Pin-----	2
43	52826 H	Differential Feed Dog, for Style 52800 BX-----	1
44	52805 X-16	Main Feed Dog, for Style 52800 BX-----	1
45	52824 X-16	Throat Plate, for No. 16 gauge, Style 52800 BX -----	1
46	52820 X-16	Presser Foot, for Style 52800 BX -----	1
47	91	Screw -----	1
48	52830 X-16	Presser Foot Bottom -----	1

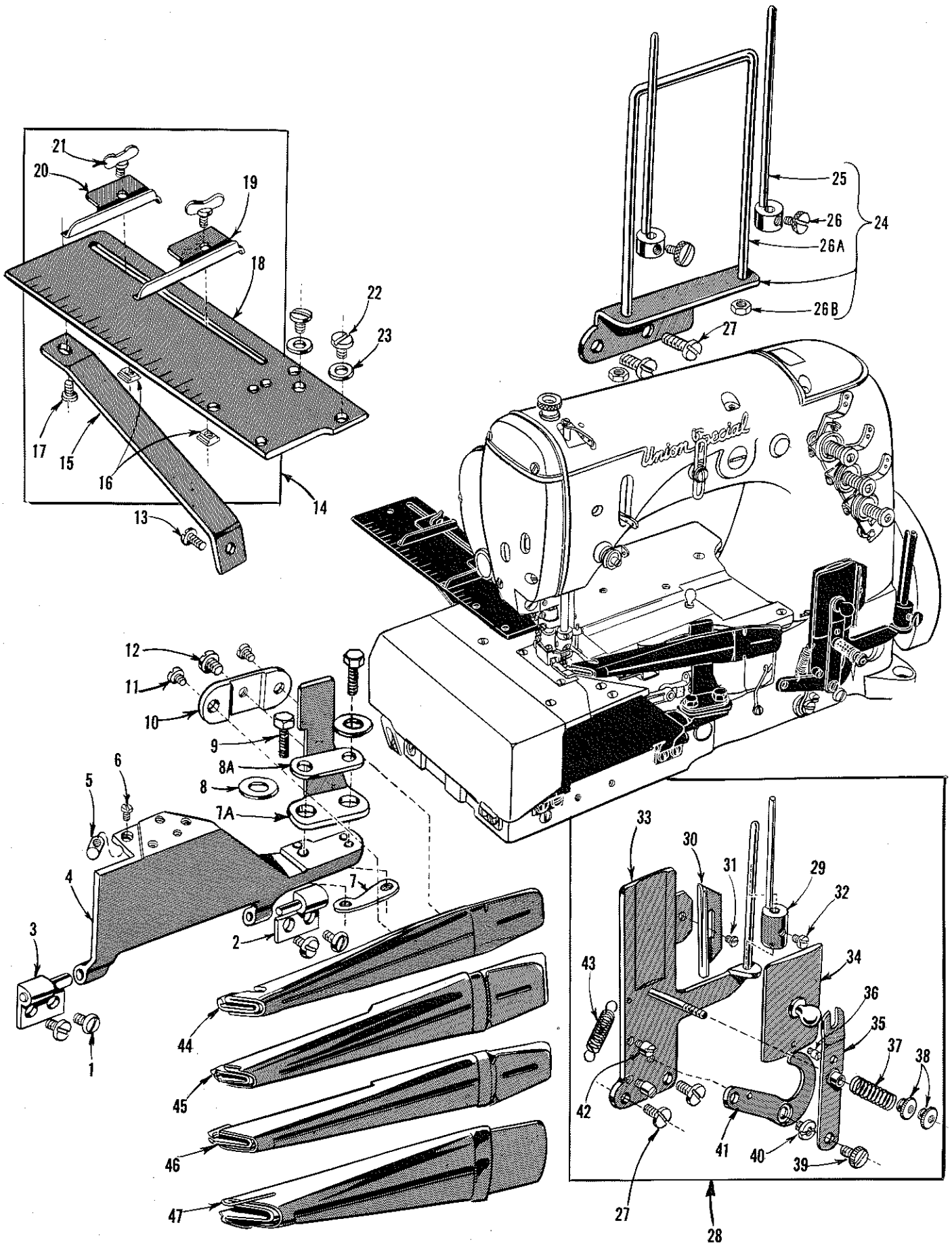

ATTACHMENTS

Ref. No.	Part No.	Description	Amt. Req.
1	22848	Screw -----	4
2	57885	Swing Cover Hinge, right -----	1
3	52885 H	Swing Cover Hinge, left -----	1
4	57764 B	Folder Support Hinged Bracket, for all Styles except 52800 BC, BD -----	1
5	57885 A	Hinge Bracket Spring.Pin -----	1
6	22564	Screw -----	1
7	57864	Clamp Plate, for Styles 52800 BA, BP, BR, BS, BU, BV, BW, BY -----	1
7A	52864 N	Folder Support Bracket, for Styles 52800 BA, BP, BR, BS, BU, BV, BW, BY -----	1
8	53634 C	Washer, for Styles 52800 BA, BP, BR, BS, BU, BV, BW, BY -----	2
8A	23425 V	Washer Plate -----	1
9	T38	Screw -----	2
10	23432	Folder Clamp, for Styles 52800 BA, BP, BR, BS, BU, BV, BW -----	1
11	25 CC	Screw -----	2
12	25 S	Screw -----	1
13	93	Screw -----	1
14	21198 K	Measuring Gauge, for Styles 52800 BA, BP, BR -----	1
15	21198 L	Brace -----	1
16	21198 J	Lock Nut -----	2
17	94	Screw -----	1
18	21198 F	Base -----	1
19	21198 G	Slide Gauge, front -----	1
20	21198 H	Slide Gauge, rear -----	1
21	22756	Thumb Screw -----	2
22	25 S	Screw -----	2
23	21657 E	Washer -----	2
24	23439 G	Strip Tension, for Styles 52800 BR, BS, BU, BV, BW, BY -----	1
25	23439 F	Adjustable Pin -----	2
26	188 D	Screw -----	2
26A	51-561 Blk.	Guide -----	1
26B	907	Nut -----	2
27	22548	Screw -----	2
28	21182 AA	Strip Tension, for Styles 52800 BA, BP -----	1
29	23439 E	Adjustable Pin -----	1
30	21182 AE	Adjustable Strip Guide -----	1
31	22561	Screw -----	1
32	188 D	Screw -----	1
33	21182 AB	Base -----	1
34	21182 AF	Tension Plate -----	1
35	21182 AD	Operating Arm -----	1
36	22845 A	Shoulder Screw -----	1
37	1349	Spring -----	1
38	21185	Nut -----	2
39	22760	Screw -----	1
40	22504 B	Pivot Stud -----	1
41	21182 AC	Operating Lever -----	1
42	402	Screw Pin -----	2
43	11663	Spring -----	1
44		Folder (See Chart Below) -----	1
45		Folder (See Chart Below) -----	1
46		Folder (See Chart Below) -----	1
47		Folder (See Chart Below) -----	1

TABLE OF FOLDERS

Ref. No.	Part No.	Machine Style Used On	Seam Type	Strip Size	Finish Size	Strip Capacity	Uncurlers	Amt. Req.	
44	23406 L-7/16	BP-8 7/16	BR-8 7/16	BSa-1	7/8"	7/16"	.025"	†Ent. & Del.	1
	23406 L-1/2	BP-8 1/2	BR-8 1/2	BSa-1	1"	1/2"	.025"	†Ent. & Del.	1
	23406 L-5/8	BP-8 5/8	BR-8 5/8	BSa-1	1-1/4"	5/8"	.025"	†Ent. & Del.	1
	23406 L-3/4	BP-8 3/4	BR-8 3/4	BSa-1	1-1/2"	3/4"	.025"	†Ent. & Del.	1
45	23406 R-1/2	BV-8 1/2	BV-12 1/2	BSb-1	1-1/4"	1/2" top*	3/64"	†Ent. & Del.	1
	23406 R-5/8	BV-8 5/8	BV-12 5/8	BSb-1	1-1/2"	5/8" top*	3/64"	Entrance	1
	23406 U-3/4	BV-8 3/4	BV-12 3/4	BSb-1	1-3/4"	3/4" top*	3/64"	None	1
	23406 S-3/4	BV-12 3/4		BSb-1	1-13/16"	3/4" top*	5/64"	None	1
	K59055	BV-8 7/8	BV-12 7/8	BSb-1	2-1/8"	7/8" top*	3/64"	Entrance	1
	K63210	BV-8 7/8	BV-12 7/8	BSb-1	2"	7/8" top*	5/64"	None	1
	K64049	BV-8-1	BV-12-1	BSb-1	2-1/4"	1" top*	3/64"	†Ent. & Del.	1
	23406 T-1	BV-8-1	BV-12-1	BSb-1	2-1/4"	1" top*	5/64"	None	1
	K64050	BV-8-1 1/4	BV-12-1 1/4	BSb-1	2-3/4"	1-1/4" top*	5/64"	None	1
46	23406 M-1/2	BS-8 1/2	BA-8 1/2	BSa-1	1"	1/2"	3/64"	Entrance	1
	23406 M-5/8	BS-8 5/8		BSa-1	1-1/4"	5/8"	3/64"	Entrance	1
	23406 M-3/4	BS-8 3/4		BSa-1	1-1/2"	3/4"	3/64"	Entrance	1
	23406 M-7/8	BS-8 7/8		BSa-1	1-3/4"	7/8"	3/64"	Entrance	1
	23406 M-1	BS-8-1		BSa-1	2"	1"	3/64"	Entrance	1
47	23406 N-3/4	BU-8 3/4	BW-14 3/4	BSa-1	1-1/2"	3/4"	5/64"	None	1
	23406 N-7/8	BU-12 3/4	BW-16 3/4	BSa-1	1-3/4"	7/8"	5/64"	None	1
		BU-8 7/8	BW-14 7/8						
	23406 N-1	BU-12 7/8	BW-16 7/8	BSa-1	2"	1"	5/64"	None	1
BU-8-1		BW-14-1							
23406 N-1 1/4	BU-12-1	BW-16-1	BSa-1	2-1/2"	1-1/4"	5/64"	None	1	
	BU-8-1 1/4	BW-14-1 1/4							
		BU-12-1 1/4	BW-16-1 1/4						

* Above folders, producing seam Type BSb-1, finish 1/16" wider on top than on bottom with 1/16" margin to left of left hand needle.

† Entrance and delivery ends.

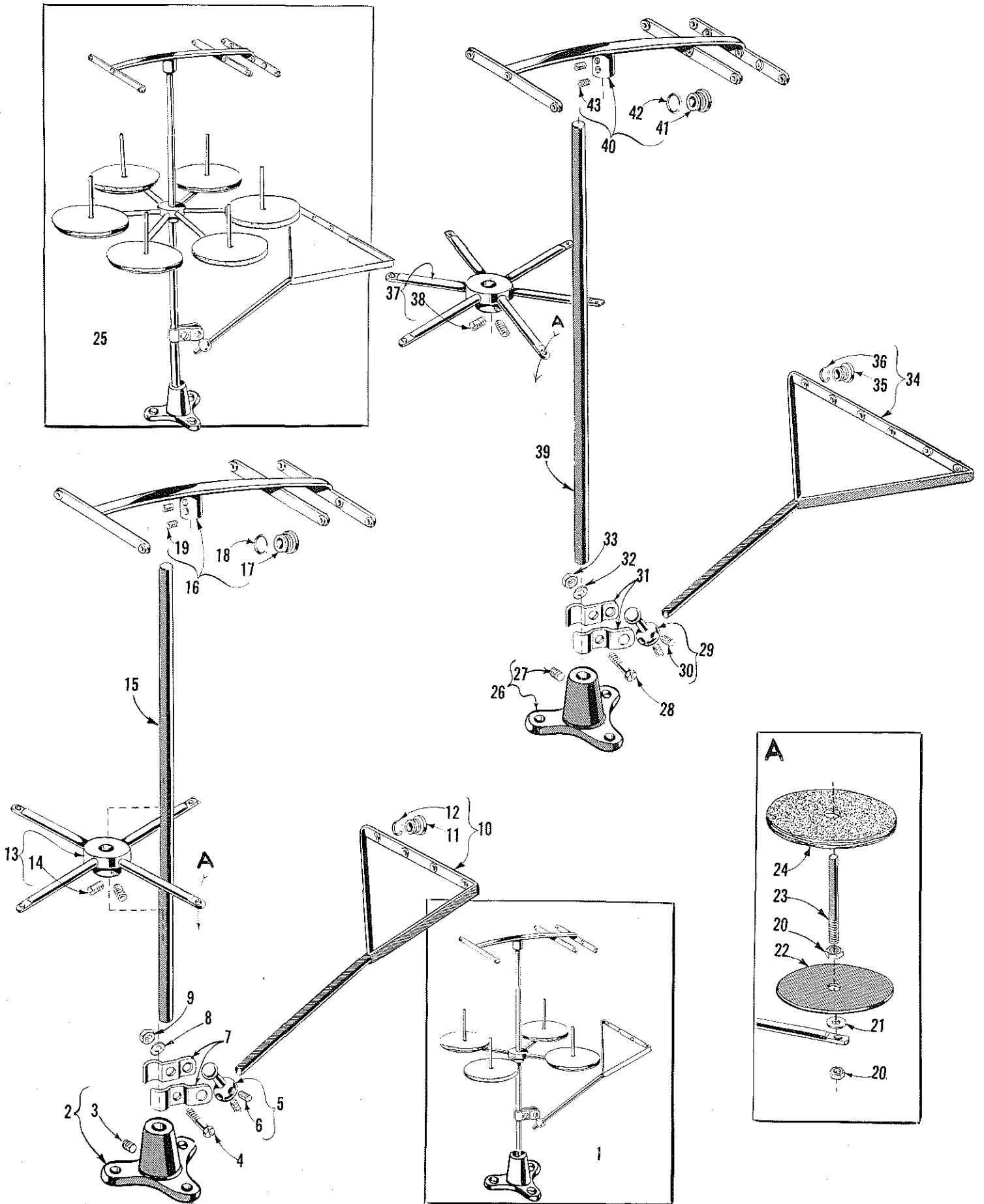

THREAD STAND PARTS

Ref. No.	Part No.	Description	Amt. Req.
1	21101 H-4	Thread Stand Assembly, for Styles 52800 BA, BD, BF, BP, BR, BS, BT, BU, BV, BY -----	1
2	21114 A	Thread Stand Base -----	1
3	22651 CD-4	Screw-----	1
4	22810	Screw-----	1
5	21114 T	Lead Eyelet Socket Ball-----	1
6	22651 CD-4	Screw-----	2
7	21114 U	Lead Eyelet Ball Split Socket -----	2
8	652-16	Washer -----	1
9	21104 H	Nut -----	1
10	21114 S-4	Lead Eyelet -----	1
11	21114 L	Eyelet -----	4
12	21114 M	Eyelet Locking Ring -----	4
13	21114 D-4	Spool Seat Support-----	1
14	22651 CD-5	Screw-----	2
15	21104 B-24	Thread Stand Rod -----	1
16	21114 H-4	Eyelet Support -----	1
17	21114 L	Eyelet -----	8
18	21114 M	Eyelet Locking Ring -----	8
19	22651 CD-4	Screw-----	2
20	258 A	Nut -----	8
21	652-16	Washer -----	4
22	21114	Spool Seat Disc -----	4
23	21114 W	Spool Pin-----	4
24	21104 V	Felt Pad -----	4
25	21101 H-6	Thread Stand Assembly, for Styles 52800 BC, BE, BM, BN, BW, BX-----	1
26	21114 A	Thread Stand Base -----	1
27	22651 CD-3	Screw-----	1
28	22810	Screw-----	1
29	21114 T	Lead Eyelet Socket Ball-----	1
30	22651 CD-4	Screw-----	2
31	21114 U	Lead Eyelet Ball Split Socket -----	2
32	652-16	Washer -----	1
33	21104 H	Nut -----	1
34	21114 S-6	Lead Eyelet -----	1
35	21114 L	Eyelet -----	6
36	21114 M	Eyelet Locking Ring-----	6
37	21114 D-6	Spool Seat Support-----	1
38	22651 CD-5	Screw-----	2
39	21104 B-24	Thread Stand Rod -----	1
40	21114 H-6	Eyelet Support -----	1
41	21114 L	Eyelet -----	12
42	21114 M	Eyelet Locking Ring -----	12
43	22651 CD-4	Screw-----	2

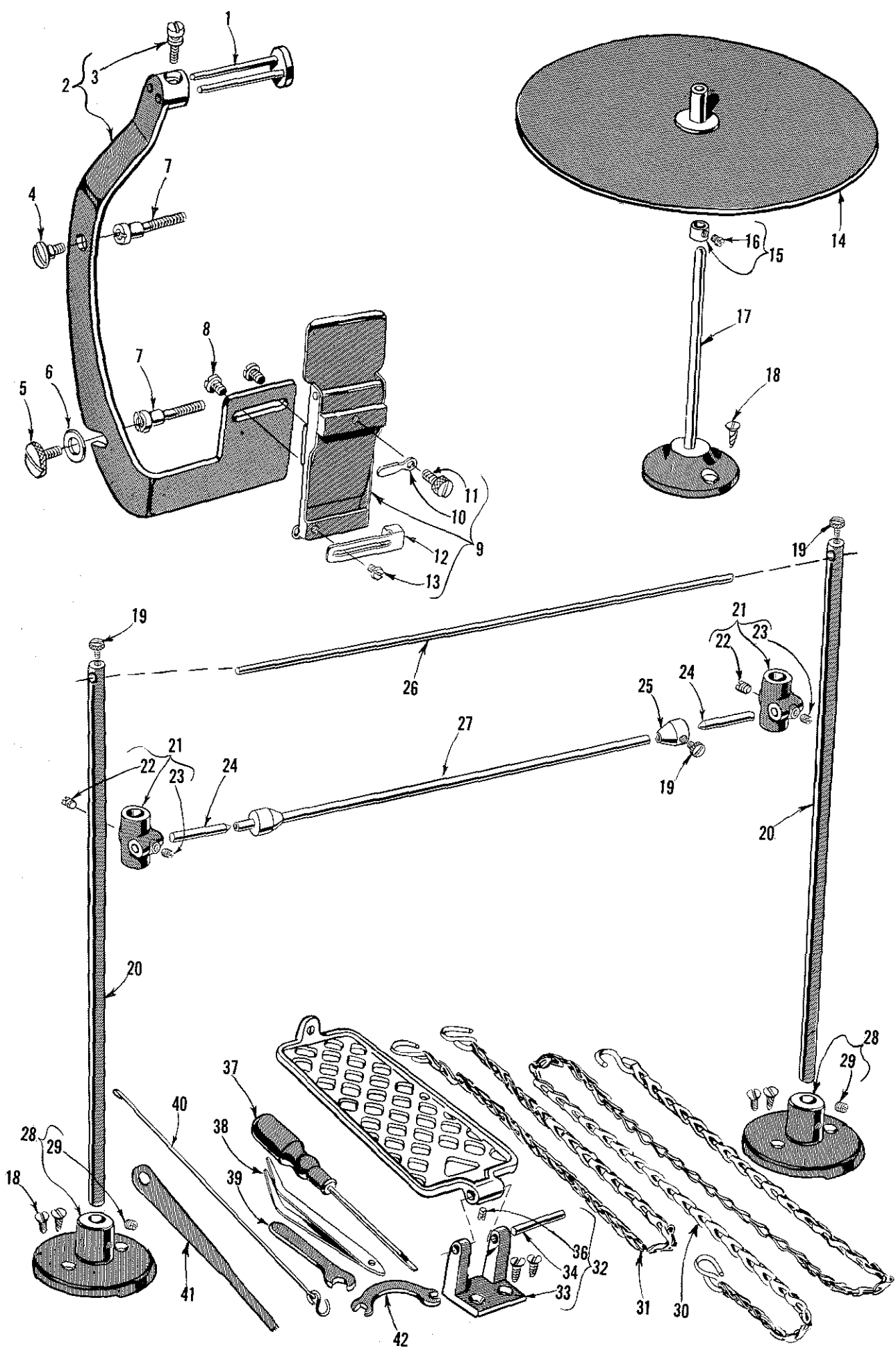

STRIP TENSION PARTS, STRIP HOLDING PARTS AND ACCESSORIES

Ref. No.	Part No.	Description	Amt. Req.
1	23306 Q	Strip Guide, for Style 52800 BT -----	1
	23306 A	Strip Guide, for Styles 52800 BC, BD, BE, BF -----	1
2	23306 AA	Strip Guide Support, for Styles 52800 BC, BD, BE, BF, BT -----	1
3	22568	Screw -----	1
4	22504 C	Screw, for Styles 52800 BC, BD, BE, BF, BT -----	1
5	22837	Thumbscrew, for Styles 52800 BC, BD, BE, BF, BT -----	1
6	12957 E	Washer, for Styles 52800 BC, BD, BE, BF, BT -----	1
7	52882 V	Stud, for Styles 52800 BC, BD, BE, BF, BT -----	2
8	94	Screw, for Styles 52800 BC, BD, BE, BF, BT -----	2
9	23306 Z	Strip Guide and Tension Assembly, for Style 52800 BT ----	1
	23306 AE	Strip Guide and Tension Assembly, for Styles 52800 BC, BD, BE, BF -----	1
10	23306 AF	Tension Adjusting Lock Nut -----	1
11	22703	Tension Thumbscrew -----	1
12	23306 T	Adjustable Strip Guide, for No. 23306 Z -----	1
	23306 W	Adjustable Strip Guide, for No. 23306 AE -----	1
13	25 B	Screw -----	1
14	21169 E	Binding Holder Disc, for Styles 52800 BA, BP, BR, BS, BU, BV, BW, BY -----	1
15	161	Binding Holder Stop Collar, for Styles 52800 BA, BP, BR, BS, BU, BV, BW, BY -----	1
16	88	Screw -----	1
17	21169 F	Binding Holder Base, for Styles 52800 BA, BP, BR, BS, BU, BV, BW, BY -----	1
18	SC303	Wood Screw #12-1" long -----	2
19	188 D	Screw, for Styles 52800 BC, BD, BE, BF, BT -----	3
20	21216	Spool Support Upright Rod, for Styles 52800 BC, BD, BE, BF, BT -----	2
21	21217 A	Pin Support, for Style 52800 BT -----	2
22	22651 CD-4	Screw -----	2
23	22650 CB-4	Screw -----	2
24	751 A	Pin, for Style 52800 BT -----	2
25	753	Axle Cone, for Styles 52800 BC, BD, BE, BF, BT -----	1
26	21102 B	Guide Holder Supporting Rod, for Styles 52800 BC, BD, BE, BF, BT -----	1
27	752	Axle, for Style 52800 BT -----	1
28	21114 A	Spool Support Base, for Styles 52800 BC, BD, BE, BF, BT -----	2
29	22651 CD-4	Screw -----	1
30	421 D-38	Treadle Chain, 38 inches long, for Styles 52800 BA, BP, BR -----	1
31	421 D-28	Treadle Chain, 28 inches long -----	1
32	29402	Lifter Treadle Assembly, for Styles 52800 BA, BP, BR ---	1
33	423	Lifter Treadle Rest -----	1
34	424	Lifter Treadle Pin -----	1
36	22813	Screw -----	1
37	21201	Screwdriver, 9/64 inch round blade, length over all 7 5/8 inches -----	1
38	660-240	Thread Tweezer -----	1
39	21388	Wrench, single end, 3/8 inch opening -----	1
40	51493 BC	Lifter Link -----	1
41	23279 D	Folder Threader, for Styles 52800 BA, BC, BD, BF, BP, BR, BS, BU, BV, BW, BX, BY -----	1
42	21388 W	Wrench, double end, curved, 9/32 inch opening -----	1

NUMERICAL INDEX OF PARTS

Part No.	Page No.	Part No.	Page No.	Part No.	Page No.	Part No.	Page No.
WO-3	15	660-240	35	21169 E	35	22711	9
8	21,23	660-244	15	21169 F	35	22716 A	29
18	15,17,19	660-246	15	21182 AA	31	22729	15
20	9,19,21	660-614	15	21182 AB	31	22729 A	13
HA20 A	15	666-65	13	21182 AC	31	22729 B	13
CL21	17,21,23	666-99	13	21182 AD	31	22733 B	11
25 B	35	666-111	13	21182 AE	31	22735	11
25 C	11	666-114	13	21182 AF	31	22743	15
25 S	31	666-118	13	21185	31	22747	21,23
25 CC	23,31	666-149	21	21198 F	31	22756	31
27-435 Blk	15	666-170	15	21198 G	31	22758 B	23
28 B	17	666-179	13	21198 H	31	22758 C	25
28 C	17	666-201	13	21198 J	31	22760	31
T38	31	666-209	13	21198 K	31	22768	9,15,19,
50-216 Blk	9	666-214	13	21198 L	31		21
50-458 Blk	19	668-25	17,25	21201	35	22729 B	27
50-648 Blk	9,13	668-28	17,25	21212	13	22799 M	9
50-789 Blk	9	719	9,23	21216	35	22801	21
51-561 Blk	31	751 A	35	21217 A	35	22810	33
52 A	9	752	35	BB21375 AH	9	22813	35
67 WD	29	753	35	21388	35	22823 A	13
G65-134	29	907	21,23,31	21388 W	35	22823 B	13
73	19	1349	31	21657	25	22829	19
73 A	9,15,27	3026 A	29	21657 E	9,31	22837	35
75	21	5003	11	21657 W	25	22839	11
77	15,21,23	5005 R	29	21657 X	13	22839 C	11
77 A	25	5024 B	29	21657 Y	25	22845 A	31
80	11	5024 M	29	22504 B	31	22848	9,11,23,
82	21	5041	29	22504 C	35		31
87	11	5105 B	29	22513	9	22868 A	23
87 U	9	5126	29	22516	9,21,23	22872	17
88	19,25,35	5126 B	29	22517 C	9	22882 A	19
88 B	17	5127 C	29	22519 C	21,23	22889 A	9
89	17,21,23	5127 H	29	22519 H	19	22894 D	21,23
90	9,11,13,	5140	29	22519 J	21,23	22894 G	15
	21,23	5141	29	22524	11	22894 X	15
91	27,29	5141 A	29	22528	9	23133 L	11
93	9,31	6042 A	17	22537	25	23133 M	11
93 A	11	8372 A	23	22539 D	9	23195	29
94	31,35	9937	23	22539 H	13	23279 D	35
95	15,17	10303 A	11	22541 B	9	23306 A	35
96	19	11534	27	22542	9	23306 Q	35
98	3,19,21	11663	31	22548	11,31	23306 T	35
98 A	9	12934 A	17,23	22557 B	25	23306 W	35
109	17,25	12957 E	11,35	22559 A	15	23306 Z	35
161	35	13105 B	29	22559 G	15	23306 AA	35
187 A	29	13120 F	27	22560 B	13,15,21,	23306 AE	35
188 D	31,35	13124 B	29		23	23306 AF	35
258 A	13,19,33	13130 A	27	22561	11,27,31	23406 L	31
269	17,19,21	13130 B	27	22562	25	23406 M	31
294	9,13	13130 F	27	22562 A	15	23406 N	31
SC303	35	15037 A	17	22563	19	23406 R	31
357	11	15438 B	9	22564	15,31	23406 S	31
402	25,31	15438 C	9	22565 C	21,23	23406 T	31
421 D	35	15438 D	9	22568	35	23406 U	31
423	35	15465 F	19	22569 B	13,15	23425 V	11,31
424	35	21101 H	33	22571 A	13	23432	31
482	21,23	21102 B	35	22572 A	9	23439 F	31
531	13,25	21104 B	33	22580 D	21	23439 G	31
539	9	21104 H	33	22585 A	11	29066 R	15
604	29	21114	33	22586 R	15	29126 CR	15
605	27,29	21114 A	33,35	22587	15	29192 T	19
643-127 Blk	13	21114 D	33	22587 H	15	29264 S-16	17
643-263 Blk	13	21114 H	33	22593 A	21,23	29348 AF	15
652-16	33	21114 L	33	22596	25	29402	35
660-136	13	21114 M	33	22597	9	29476 DV	23
660-169	21	21114 S	33	22645 H-64	13	29476 DX	21
660-202	15,17,25	21114 T	33	22650 CB-4	35	29476 HL	15
660-207	25	21114 U	33	22651 CD	33,35	29476 LE	15
660-212	15	21114 V	33	22703	35	29480 LY	19
660-215	15	21114 W	33	22706 A	13	33174 B	19

NOTE: Only the basic part numbers are shown in the index. For various gauges, capacities, etc. available, refer to the listings on pages indicated.

NUMERICAL INDEX OF PARTS

Part No.	Page No.	Part No.	Page No.	Part No.	Page No.	Part No.	Page No.
35178 D.....	13	51493 E.....	13	52834 H.....	21,23	52942 A.....	15
35582 B.....	9	51493 AG.....	13	52834 N.....	21	52942 P.....	19
35731 A.....	9	51493 AH.....	13	52835.....	23	52942 R.....	19
35772 D.....	11	51493 AZ.....	13	52835 G.....	23	52942 W.....	13
39236 B.....	21	51493 BC.....	35	52835 K.....	23	52942 Y.....	9
39236 C.....	21	51493 BG.....	13	52835 N.....	23	52943 L.....	15
39236 V.....	21	51493 BH.....	13	52835 Q.....	23	52944 T.....	13
39237.....	21,23	51493 BJ.....	13	52835 S.....	23	52944 U.....	13
39237 D.....	21,23	51493 BK.....	13	52835 T.....	21	52945 M.....	25
39237 G.....	21,23	51493 BP.....	15	52835 U.....	23	52947 A.....	15
39552 C.....	25	51493 BQ.....	13	52835 V.....	23	52951 A.....	15
39582 L.....	9	51745.....	19	52836.....	21,23	52951 B.....	15
39595.....	13	52336 A.....	15	52836 C.....	21,23	52951 C.....	15
41076 D.....	15	52444 B.....	19	52836 G.....	21	52952 B.....	15
41355 U.....	19	52708 BA.....	19	52836 H.....	23	52952 C.....	17
41394 A.....	11	52717 E.....	17	52836 N.....	21	52957 C.....	9
43139 A.....	23	52730.....	29	52841 A.....	19	52958 B.....	9
43266.....	17,25	52730 A.....	29	52842 A.....	15	52958 D.....	9
43281 K.....	11	52730 C.....	29	52842 G.....	17	52978 V.....	11
51054.....	21	52730 X.....	29	52844 A.....	9	52982 D.....	11
51134 C.....	21,23	52794 G.....	13	52846 A.....	25	52982 E.....	11
51144.....	19	52801 G.....	11	52847.....	25	52982 F.....	11
51145 A.....	21,23	52802 C.....	11	52848 B.....	17	52985.....	9
51147.....	17	52802 D.....	11	52848 C.....	17	52985 A.....	9
51154 D.....	13	52804 E.....	9	52849.....	17	52994 U.....	13
51216 G.....	15	52805 B.....	29	52849 B.....	17	52994 V.....	13
51216 M.....	15	52805 D.....	29	52849 C.....	17	53634 C.....	31
51216 N.....	15,19	52805 K.....	27	52853.....	21,23	53688.....	25
51216 P.....	15	52805 M.....	29	52853 A.....	17	53783 A.....	25
51225 W.....	21,23	52805 X.....	29	52855 A.....	17	53783 L.....	25
51235 G.....	21,23	52813.....	19	52855 G.....	17	53783 N.....	25
51236 A.....	21,23	52817.....	17	52858.....	9	55235 D.....	17
51236 B.....	21	52817 E.....	17	52864 N.....	31	55235 E.....	17
51236 D.....	21	52818.....	17	52864 R.....	11	55244 G.....	19
51236 E.....	21	52820 H.....	27	52864 T.....	11	56315 A.....	15
51236 F.....	21	52820 K.....	27	52864 U.....	11	56341 G.....	19
51236 G.....	21	52820 M.....	27	52880.....	11	56343 D.....	15
51240 D.....	17	52820 T.....	29	52882 P.....	9	56350 D.....	15
51242 M.....	19	52820 X.....	29	52882 R.....	9	56350 F.....	15
51243 C.....	15	52822 A.....	21	52882 S.....	9	56350 G.....	15
51244 B.....	19	52824 B.....	29	52882 U.....	11	56350 H.....	15
51244 L.....	19	52824 D.....	29	52882 V.....	35	56354 D.....	15
51244 N.....	19	52824 F.....	27	52882 W.....	9	56382 X.....	25
51246.....	19	52824 K.....	27	52882 Z.....	9	56382 AC.....	9
51250 D.....	15	52824 M.....	29	52882 AA.....	9	56383 AB.....	25
51250 F.....	15	52824 X.....	29	52882 AC.....	9	56390 E.....	13
51254 C.....	13	52825 A.....	21	52882 AD.....	9	56458.....	15
51254 K.....	15	52825 B.....	21,23	52882 AF.....	11	56458 A.....	15
51256 C.....	25	52825 C.....	19	52883 R.....	13	56958.....	15
51257 M.....	25	52825 D.....	19	52883 S.....	25	56958 A.....	15
51280 J.....	11	52825 E.....	21	52885 B.....	25	57705 A.....	27
51283 H.....	25	52825 F.....	21,23	52885 H.....	31	57726.....	27
51290 T.....	13	52826.....	29	52885 L.....	9	57764 A.....	11
51291 A.....	9	52826 G.....	29	52889 A.....	25	57764 B.....	31
51292.....	17	52826 H.....	29	52890 C.....	13	57824 A.....	27
51292 A.....	17,25	52826 K.....	27	52891 B.....	13	57836 F.....	23
51292 C.....	17,25	G52827-1.....	29	52892.....	25	57840.....	19
51292 D.....	17,25	G52827-2.....	29	52894 K.....	13	57842 B.....	13
51292 F.....	17,25	G52827-16.....	29	52894 AB.....	13	57864.....	31
51292 G.....	25	52828 D.....	29	52894 AD.....	13	57885.....	9,31
51294 K.....	13	52828 F.....	27	52894 AE.....	13	57885 A.....	31
51294 U.....	13	52828 K.....	27	52894 AK.....	13	57885 B.....	9
51294 Y.....	13	52830 C.....	27	G52897 A-16.....	29	K59055.....	31
51295 B.....	13	52830 D.....	27	52904 B.....	9	61267 G.....	23
51306.....	21	52830 G.....	29	52904 E.....	9	K63210.....	31
51382 A.....	11	52830 H.....	27	52904 G.....	9	K64049.....	31
51406.....	23	52830 K.....	27	52916.....	15	K64050.....	31
51435.....	23	52830 M.....	27	52921 B.....	15	K70991.....	19
51435 B.....	23	52830 N.....	27	52923 D.....	21		
51491 C.....	25	52830 X.....	29	52925 D.....	21,23		
51493 D.....	13	52834.....	21,23	52936.....	13		

NOTE: Only the basic part numbers are shown in the index. For various gauges, capacities, etc. available, refer to the listings on pages indicated.

Union Special Wants to Help You Cut Sewing Machine Maintenance Costs

Union Special is offering two practical systems to help pinpoint and reduce your sewing machine maintenance costs: a record keeping system to help spot machines requiring abnormally high maintenance, and a parts inventory system to speed routine repairs.

Machine Maintenance Records

Repair-prone machines or inexperienced competent operators can eat up your maintenance dollars in short order. To help spot these problems, Union Special suggests two variations of a simple maintenance record keeping system using cards provided by Union Special.

The first system utilizes a "Machine Maintenance Record" card (Form 237) for each sewing machine in a plant. When a repair is required, the card is pulled from the file and the repair date, parts used, and their cost are entered in the spaces provided and the card is refiled.

**FORM 237—
Machine Maintenance
Record card**

The second system is normally used when more detailed information on repair costs is desired. Two record cards are used: a "Repair Request Card" (Form 234), and a "Machine Repair Record" (Form 233). When a machine requires service, the forelady or foreman fills out the top of a "Repair Request Card" and gives it to a mechanic. He fills in the time the repair work is started, the parts used and their cost,

and the completion time. This data is then transferred to the permanent "Machine Repair Record" kept in the office.

Whichever system is used, management now has an invaluable tool to reduce needless maintenance costs.

Repair Part Inventories

While record keeping tells management which machines require abnormally high maintenance, it does little to help reduce the downtime caused by routine repairs. To alleviate this situation, Union Special recommends that manufacturers establish a formal parts inventory system for each type of sewing machine they operate.

Excessive machine downtime and wasted hours by mechanics can be eliminated with an orderly in-plant inventory of the most commonly needed parts. There is no longer a need to cannibalize other machines for spare parts. Long waits for deliveries are avoided and machine downtime is kept to a minimum. The cost of a parts inventory is small when the overall savings are considered.

**FORM 233—
Machine Repair Record card**

**FORM 234—
Repair Request Card**

For free sample copies of the machine record cards and spare part inventory lists for a variety of the most popular machines, contact your local Union Special Representative or write direct to Union Special.

U *Union Special*
FINEST QUALITY

Style 52800 BN-16

Suggested Minimum Spare Parts List*

Part Number	Description	Minimum Quantity Per 5 Machines	Part Number	Description	Minimum Quantity Per 5 Machines
G 52827-16	Presser foot	1	88 B	Needle clamp screw	4
91	Presser foot clamp screw	2	28 C	Needle clamp screw	2
52805 D-16	Main feed dog	1	41076 D	Spreader thread eyelet	2
22593	Main feed dog screw	4	73 A	Spreader thread eyelet screw	4
3026 A	Differential feed dog	1	22743	Spreader thread eyelet holder screw	4
90	Differential feed dog screw	2	52945 M	Spreader	2
52824 D-16	Throat plate (12 to 15 S.P.I.)	1	77 A	Spreader set screws	4
or			88	Spreader holder screws	4
52828 D-16	Throat plate (16 to 18 S.P.I.)	1	52844 A	Spreader thread guide	1
87	Throat plate screw	4	90	Spreader thread guide screws	4
121 GBS	Needles (specify size)	300	52904 G	Cast-off wire	2
52708 B	Looper	2	73 A	Cast-off wire screws	2
73	Looper set screw	2	22564	Needle bar clamp screw	2
22563	Looper needle guard screw	4	21225	Looper gauge	1
33174 B	Looper needle guard holder screw	4	21227 C-14	Spreader gauge	1
52842 G	Needle thread guide wire	2	29484	Screw assortment	1
28 B	Needle thread guide wire screw	4			

*The parts and quantities listed above are intended to assist you in setting up the initial inventory of spare parts. An efficient inventory can only be established according to actual usage. The nature of the sewing operation will determine actual usage.

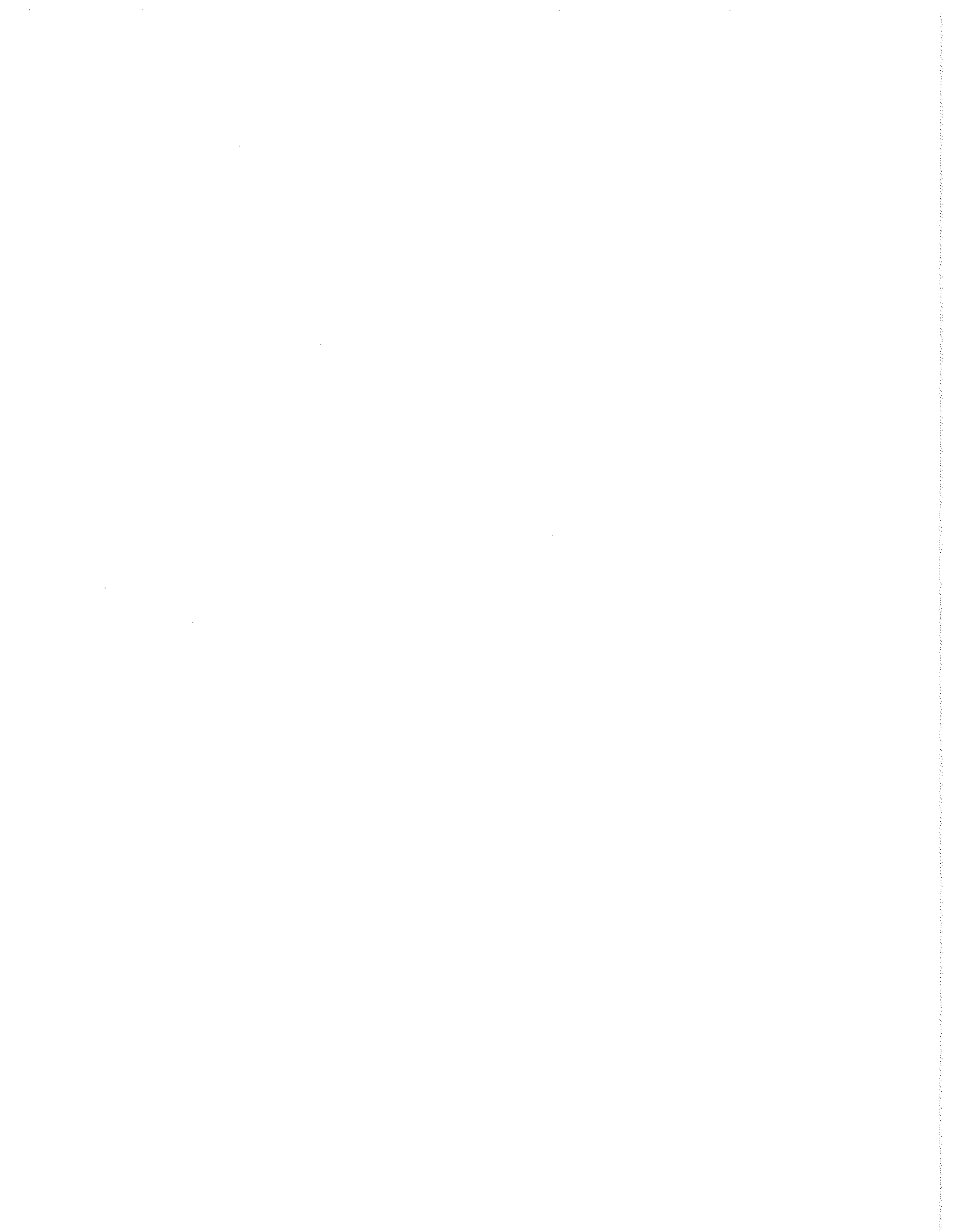

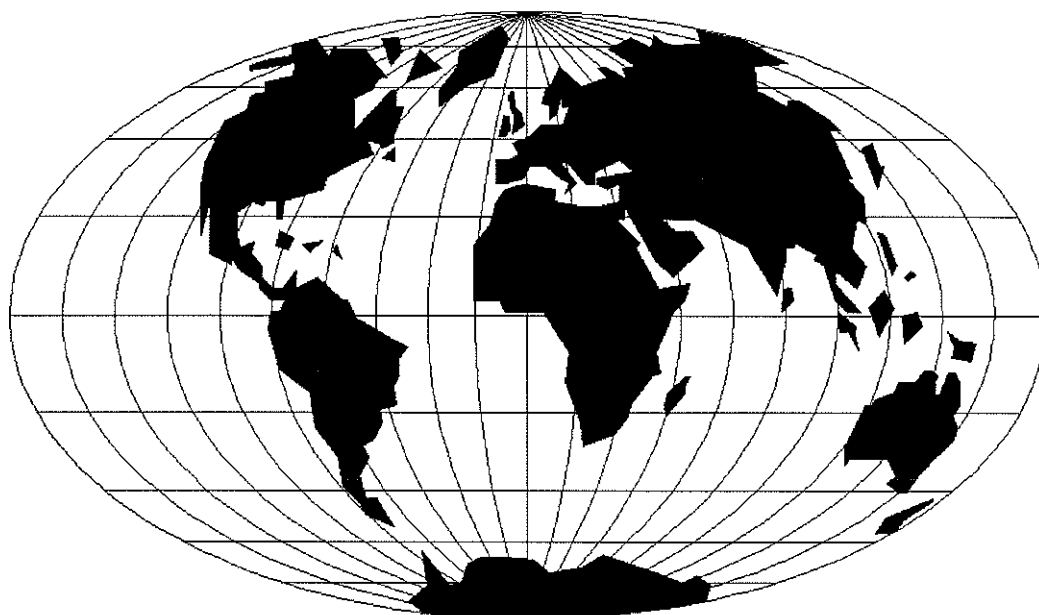

WORLDWIDE SALES AND SERVICE

Union Special Corporation maintains sales and service facilities throughout the world. These offices will aid you in the selection of the right sewing equipment for your particular operation. Union Special Corporation representatives and service technicians are factory trained and are able to serve your needs promptly and efficiently. Whatever your location, there is a qualified representative to serve you.

Corporate Office: One Union Special Plaza
Huntley, IL 60142
Phone: 847•669•5101
Fax: 847•669•4454

European Distribution Center: Union Special GmbH
Raiffeisenstrasse 3
D-71696 Möglingen, Germany
Tel: 49•07141•247•0
Fax: 49•07141•247•100

Brussels, Belgium
Charlotte, N.C.
Hong Kong, China
Huntley, IL
Leicester, England
Lille, France
Miami, FL
Milan, Italy
Möglingen, Germany
Montreal, Quebec
Osaka, Japan
Santa Fe Springs, CA
Suwanee, GA
Wayne, NJ

Other Representatives throughout
all parts of the world.



Union Special
INDUSTRIAL SEWING EQUIPMENT