

**FINEST QUALITY**

*Union Special*<sup>®</sup>  
LEWIS<sup>®</sup> • COLUMBIA<sup>®</sup>

**INDUSTRIAL  
SEWING  
MACHINES**

PROPERTY OF  
DEVELOPMENT/CATALOG DEPT.

Please return to the Catalog Dept.

Date received to file: \_\_\_\_\_

**STYLES**

**51100BM**

**51100BP**

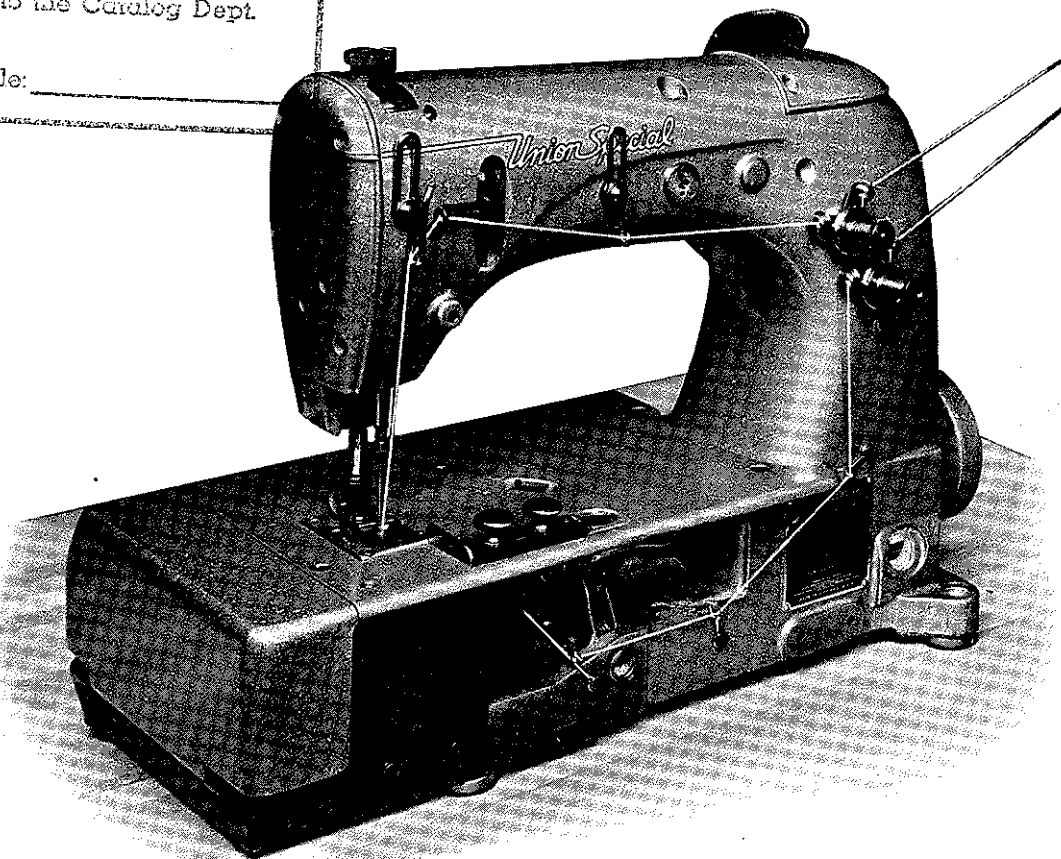

**CATALOG**

**No.**

**104M**

**CLASS 51100**

**STREAMLINED**

**FIFTY THOUSAND SERIES**

**UNION SPECIAL CORPORATION**

**CHICAGO**

Catalog No. 104 M

LIST OF PARTS

Styles

51100 BM                      51100 BP

First Edition

Copyright 1957

By

Union Special Corporation  
Rights Reserved in All Countries

**UNION SPECIAL CORPORATION**

INDUSTRIAL SEWING MACHINES

**CHICAGO**

Printed in U.S.A.

November, 1978

## FOREWORD

The 51100 streamlined machines covered by this catalog represent the latest design of the UNION SPECIAL flat bed bag seaming machine. Automatic lubrication, with a pump for returning filtered oil to the main reservoir, has made maintenance simple. All parts are made by precision methods insuring complete interchangeability.

It is our constant aim to furnish carefully prepared information that will enable the customer to secure all possible advantages from the use of UNION SPECIAL sewing machines. The following pages illustrate and describe the parts used in the 51100 bag seaming machines covered by this catalog.

In all manufacturing centers will be found Union Special representatives, who will cooperate with those who desire in planning and estimating their requirements.

**UNION SPECIAL CORPORATION**

Engineering Department

## IDENTIFICATION OF MACHINE

Each UNION SPECIAL carries a Style number which is stamped in the name plate on the machine. Style numbers are classified as standard and special. Standard Style numbers have one or more letters suffixed, but never contain the letter "Z". Example: "Style 51100 BP". Special Style numbers contain the letter "Z". When only minor changes are made in a standard machine, a "Z" is suffixed to the standard Style number. Example: 51100 BPZ".

Styles of machines similar in construction are grouped under a Class number which differs from the Style number in that it contains no letters. Example: "51100".

## APPLICATION OF CATALOG

This catalog applies specifically to the standard styles of machines as listed herein.

It can also be applied with discretion to some special machines in Class 51100. All reference to direction, such as left and right, front and back, etc., are taken from the operator's position while seated at the machine. Operating direction of handwheel is toward the operator.

## DESCRIPTION OF MACHINE

Streamlined, Flat Bed, High Throw, One Needle, Lateral Looper Travel, Single Reservoir, Enclosed Automatic Lubricating System, Equipped With Filter Type Oil Return Pump, Seam Specification 401-SSa-1, Stitch Range 3 1/2 to 7 S. P. I.

51100 BM For seaming medium and large size cotton and light and medium weight burlap bags 1 5/16" needle bar travel. Light weight presser bar and needle bar driving mechanism.

51100 BP For seaming medium and large size bags, made from medium and light weight fabrics 1 1/2" needle bar travel.

## NEEDLES

Each UNION SPECIAL needle has both type and size number. The type number denotes the kind of shank, point, length, groove, finish and other details. The size number, stamped on the needle shank, denotes largest diameter of blade, measured in thousandths of an inch, midway between shank and eye. Collectively, type and size number represent the complete symbol which is given on the label of all needles packaged and sold by Union Special.

Standard needle for Styles 51100 BM, 51100 BP is Type 143 G. It is a number 2 bag, double groove, spotted, chromium plated needle and is available in sizes 185/073, 200/080, 230/090, 250/100.

To have needle orders promptly and accurately filled, an empty package, a sample needle, or the type and size number should be forwarded. Use description on label. A complete order would read: "1000 Needles, Type 143 G, Size 200/080".

Selection of proper needle size is determined by size of thread used. Thread should pass freely through needle eye in order to produce a good stitch formation.

Success in the operation of UNION SPECIAL machines can be secured only by use of needles packaged under our brand name, *Union Specials*, which is backed by a reputation for producing highest quality needles in materials and workmanship for more than three-quarters of a century.

## ORDERING REPAIR PARTS

### ILLUSTRATIONS

This catalog is arranged to simplify the ordering of repair parts. Exploded views of various sections of the mechanism are shown so parts may be seen in their actual position within the machine. Opposite the page of illustration is found a listing of parts shown, their part numbers, description and number of pieces required in the particular view shown.

Numbers in the first column are reference numbers only and indicate the position of the part within the illustration. Reference numbers should never be used in ordering parts. Always use the part number given in the second column.

Component parts of sub-assemblies which can be furnished for repairs are indicated by the fact that their descriptions are indented under the description of the main sub-assembly. Example:

<u>Ref. No.</u>	<u>Part No.</u>	<u>Description</u>	<u>Amt. Req.</u>
41	29105 Z	Looper Drive Eccentric Assembly -----	1
42	22559 B	Bearing Cap Screw, upper -----	2
43	22894 D	Spot Screw -----	1
44	22894 C	Set Screw -----	4
45	22559 A	Bearing Cap Screw, lower -----	2

It will be noted in this example that the eccentric and bearing are not listed. This is done for the reason that the replacement of the parts individually is not recommended and the complete sub-assembly should be ordered.

In those cases where a part is common to both Styles 51100 BM and 51100 BP, no specific usage will be mentioned in the descriptions. However, when the parts for both machines are not the same, the specific usage will be mentioned in the descriptions, and, if necessary, the difference will be shown in the illustration.

At the back of the book will be found a numerical index of parts shown in the illustrations, which will facilitate locating illustration and description when part number is known.

### IDENTIFYING PARTS

Where construction permits, each part is stamped with its part number. Some smaller parts are stamped only with an identification letter to distinguish them from parts similar in appearance.

All part numbers represent the same part regardless of the catalog in which they appear.

### USE GENUINE NEEDLES AND REPAIR PARTS

Success in the operation of these machines can be secured only with genuine UNION SPECIAL Needles and Repair Parts as furnished by the Union Special Corporation, its subsidiaries and authorized distributors. They are designed according to the most approved scientific principles, and are made with utmost precision. Maximum efficiency and durability are assured.

Genuine needles are packaged with labels marked *Union Special*®. Genuine repair parts are stamped with the Union Special trademark, U S Emblem. Each trademark is your guarantee of the highest quality in materials and workmanship.

## ORDERING REPAIR PARTS (Cont'd.)

### TERMS

Prices are net cash and subject to change without notice. All shipments are forwarded f. o. b. shipping point. Parcel post shipments are insured unless otherwise directed. A charge is made to cover postage and insurance.

### OILING AND THREADING INSTRUCTIONS

The oil has been drained from the machine before shipping and the reservoir must be filled before operation. Use a straight mineral oil with a Saybolt viscosity of 90 to 125 seconds at 100° Fahrenheit.

Oil is filled at the spring cap in the top cover (A) of the accompanying drawing and oil level is checked at the sight gauge (B) on front of the machine. Oil level should be maintained between red lines on the gauge. The capacity of the oil reservoir is twelve ounces.

A daily check before the morning start should be made and oil added as required. Oil which has gone thru the machine is filtered and pumped back into the main reservoir, making too frequent oilings unnecessary. Excessive oil in the main reservoir may be drained at the plug screw in the main frame directly under the handwheel. After draining oil, wipe the hole and plug screw dry, paint hole and screw with a little gasket cement, and re-assemble screw.

The accompanying diagram also shows the threading of machine Styles 51100 BM and 51100 BP.

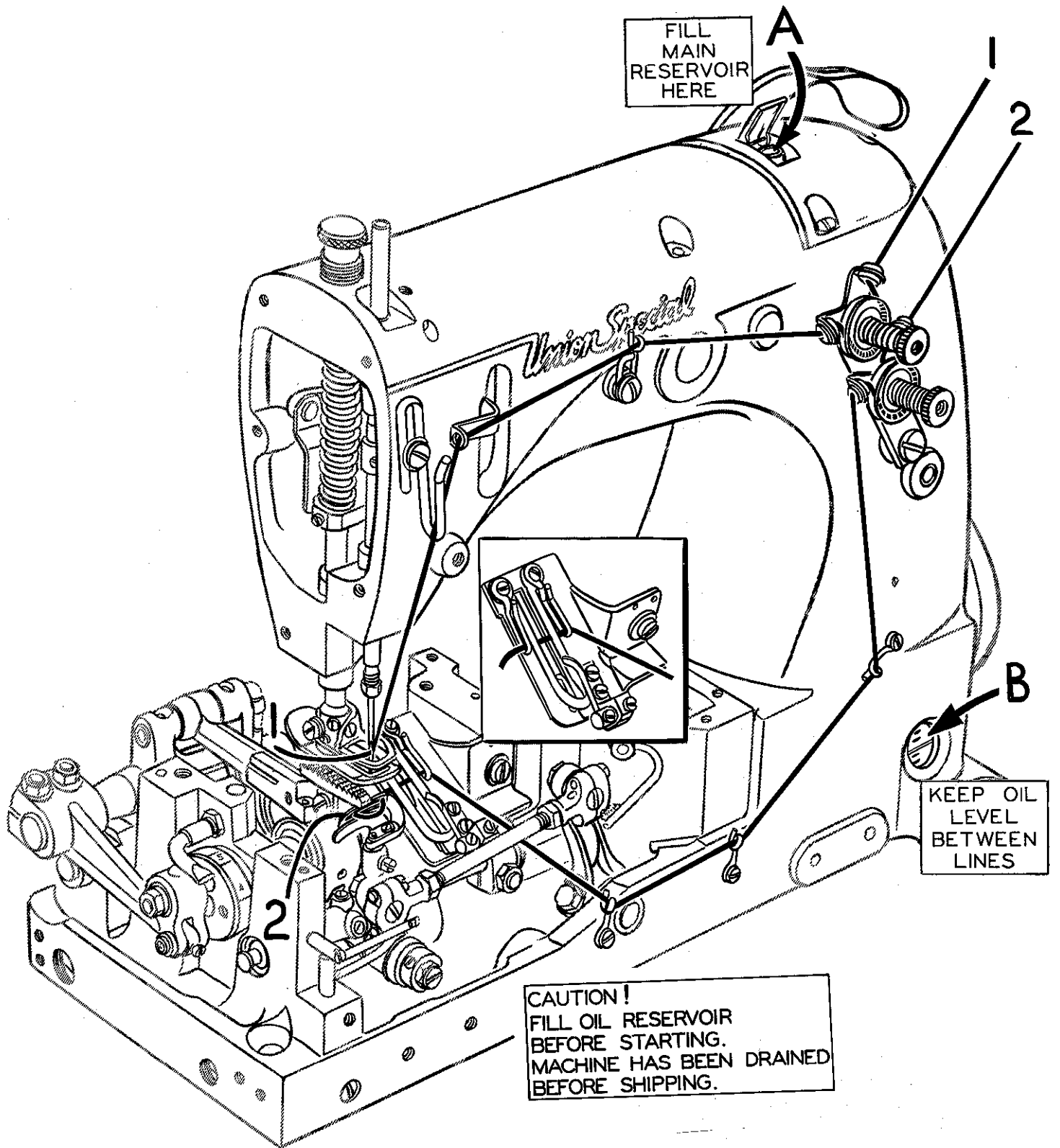

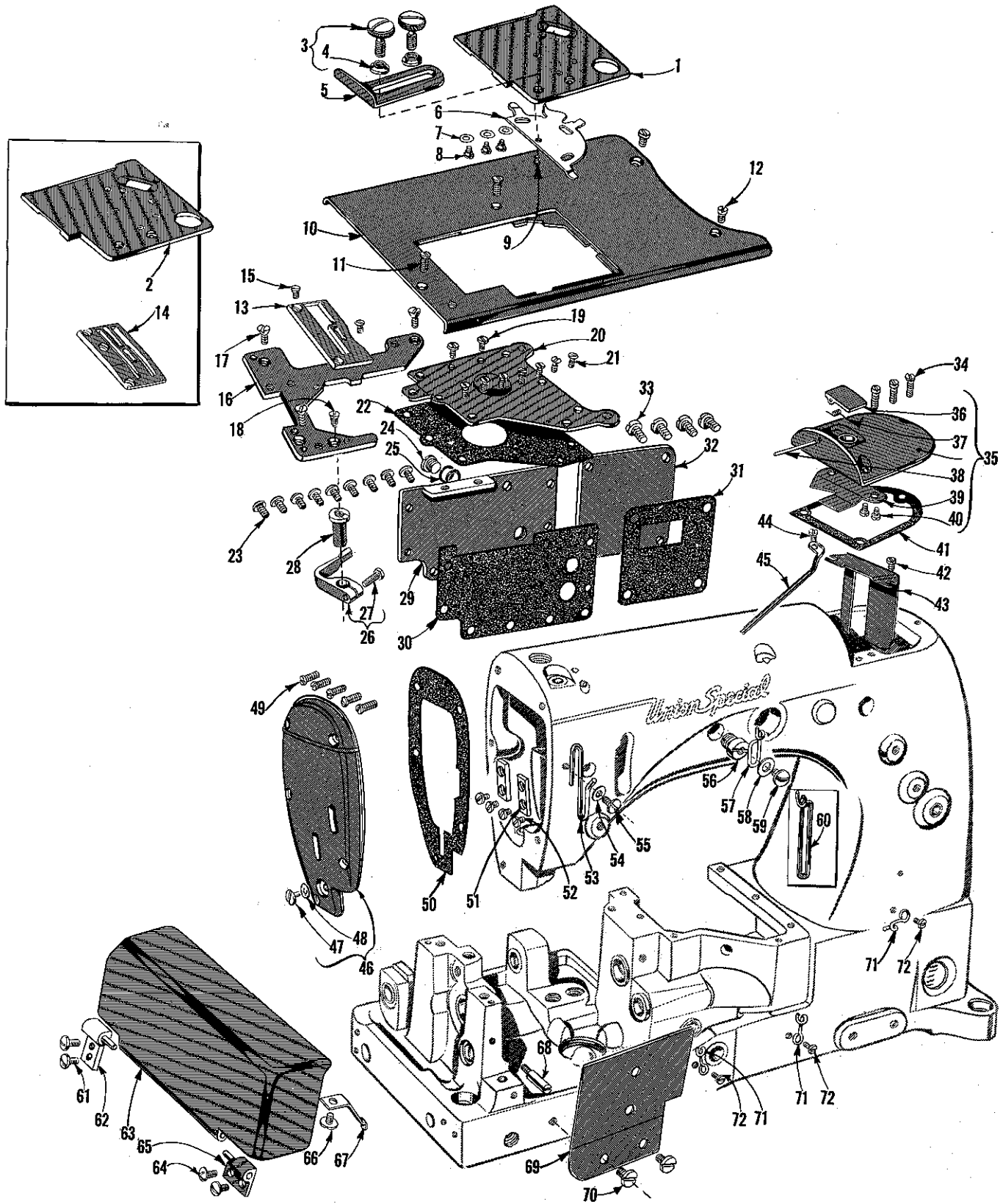



MAIN FRAME, MISCELLANEOUS COVERS AND PLATES

<u>Ref. No.</u>	<u>Part No.</u>	<u>Description</u>	<u>Amt. Req.</u>
1	51281 T-212	Cloth Plate Cover, for Style 51100 BP -----	1
2	51281 T-219	Cloth Plate Cover, for Style 51100 BM -----	1
3	25	Edge Guide Assembly Screw -----	2
4	25 D	Washer -----	2
5	24 X	Edge Guide -----	1
6	51281 AC	Cloth Plate Cover Spring -----	1
7	35772 H	Spring Washer -----	3
8	22760 A	Screw -----	3
9	22845 B	Screw -----	1
10	51101 R	Cloth Plate -----	1
11	80	Screw -----	2
12	22839 C	Screw -----	2
13	51124 D	Throat Plate, for Style 51100 BM -----	1
14	6624 L	Throat Plate, for Style 51100 BP -----	1
15	87	Screw -----	2
16	51180 J	Throat Plate Support -----	1
17	22839	Screw -----	3
18	22570 A	Screw, for Style 51100 BM -----	1
	22584	Screw, for Style 51100 BP -----	1
19	22585 A	Screw -----	2
20	53782 B	Oil Reservoir Top Cover -----	1
21	22524	Screw -----	7
22	51382 A	Gasket -----	1
23	22848	Screw -----	9
24	22733 B	Screw -----	1
25	41394 A	Gasket -----	2
26	51125 E	Needle Guard -----	1
27	906	Clamp Screw -----	1
28	56168	Needle Guard Holder -----	1
29	52882 L	Oil Reservoir Back Cover -----	1
30	52882 M	Gasket -----	1
31	52882 U	Gasket -----	1
32	52882 AF	Crank Chamber Cover -----	1
33	22548	Screw -----	4
34	22541 B	Screw -----	3
35	52882 AD	Crank Chamber Cover, upper -----	1
36	39582 L	Oil Cap -----	1
37	52882 AC	Oil Cap Spring -----	1
38	50-789 Blk.	Oil Cap Hinge Pin -----	1
39	52882 AA	Oil Drip Plate -----	1
40	90	Screw -----	2
41	52882 P	Gasket -----	1
42	90	Screw -----	1
43	51182 L	Baffle Plate -----	1
44	90	Screw -----	1
45	51282 AE	Needle Lever Bearing Oiler -----	1
46	51282 Y	Head Cover -----	1
47	22542	Screw -----	1
48	52882 W	Gasket -----	1
49	22569 B	Screw -----	5
50	51282 Z	Gasket -----	1
51	35731 A	Presser Bar Connection Guide Plate -----	2
52	22513	Screw, for Style 51100 BM -----	3
	22513	Screw, for Style 51100 BP -----	4
53	51170 E	Frame Needle Thread Guide -----	1
54	20	Washer -----	1
55	22848	Screw -----	1
56	22889 A	Adapter Screw -----	1
57	51758	Frame Thread Eyelet, for Style 51100 BM -----	1
58	20	Washer -----	1
59	22848	Screw -----	1
60	539	Frame Thread Eyelet, for Style 51100 BP -----	1
61	22596	Screw -----	2
62	57885 B	End Cover Hinge Bracket, rear -----	1
63	51182 C	End Cover -----	1
64	22848	Screw -----	2
65	57885	End Cover Hinge Bracket, front -----	1
66	22711	Screw -----	1
67	52885 L	End Cover Spring -----	1
68	22799 M	End Cover Spring Pin -----	1
69	51482 A	Guard -----	1
70	25 S	Screw -----	2
71	52 A	Eyelet -----	3
72	98 A	Screw -----	3
*	7947	Nut, for 51294 P, 51294 R, Style 51100 BM -----	1
*	51294 P	Oil Tube Clamp, for Style 51100 BM -----	1
*	51294 R	Screw, for 35731 A, 51294 P, Style 51100 BM -----	1
*	22848	Plug Screw, for belt guard screw holes, Style 51100 BM -----	2

\* Not shown on picture plate.

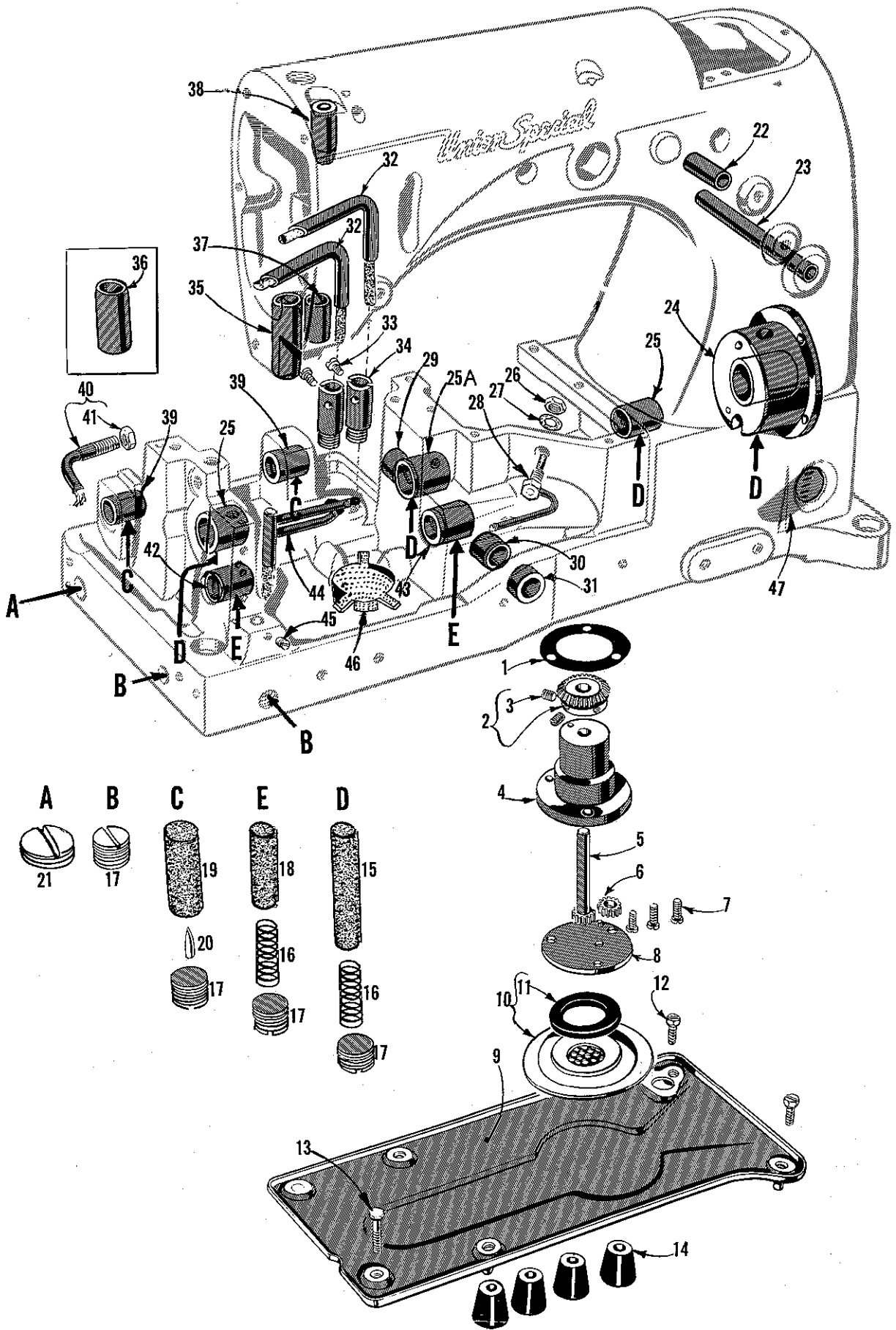

MAIN FRAME, BUSHINGS AND MISCELLANEOUS OILING PARTS

<u>Ref. No.</u>	<u>Part No.</u>	<u>Description</u>	<u>Amt. Req.</u>
1	643-127 Blk.	Gasket-----	1
2	51493 BQ	Oil Pump Driven Gear-----	1
3	531	Screw-----	2
4	51493 AG	Oil Pump Housing-----	1
5	51493 D	Oil Pump Driving Shaft-----	1
6	51493 E	Oil Pump Driving Shaft Gear-----	2
7	22569 B	Screw-----	3
8	51493 AH	Oil Pump Housing Cover-----	1
9	51493 AY	Base Plate-----	1
	*51493 BG	Base Plate Felt Pad-----	1
10	51493 BH	Filter Cap Assembly-----	1
11	51493 BJ	Washer, rubber-----	1
12	22823 A	Screw-----	2
13	22823 B	Screw-----	1
14	51295 A	Mounting Isolator-----	4
15	666-114	Oil Wick-----	4
16	35178 D	Spring-----	6
17	22571 A	Plug Screw-----	18
18	666-65	Oil Wick-----	2
19	666-111	Oil Wick-----	2
20	666-179	Wedge Pin-----	2
21	22539 H	Plug Screw-----	1
22	52883 R	Foot Lifter Lever Bushing-----	1
23	21657 X	Tension Release Lever Shaft Bushing-----	1
24	52891 B	Crankshaft Bushing Housing, including bushing-----	1
25	52890 C	Main Shaft Bushing, left and inner right-----	2
25A	51290 T	Main Shaft Bushing, center-----	1
26	258 A	Nut-----	1
27	6042 A	Washer-----	1
28	52894 AM	Oil Tube, for looper connecting rod ball joint, right-----	1
29	51242 S	Rear Looper Drive Lever Shaft Bushing-----	1
30	51242 R	Middle Looper Drive Lever Shaft Bushing-----	1
31	51242 Z	Front Looper Drive Lever Shaft Bushing-----	1
32	51193 S	Oil Tube, for feed lift eccentric; also for looper avoid eccentric-----	2
33	90	Screw-----	2
34	52894 AB	Oil Tube Holder-----	2
35	51257 AA	Lower Presser Bar Bushing, for Style 51100 BM-----	1
36	53556 C	Lower Presser Bar Bushing, for Style 51100 BP-----	1
37	51254 D	Lower Needle Bar Bushing-----	1
38	51254 C	Upper Needle Bar Bushing-----	1
39	52936	Feed Rocker Shaft Bushing-----	2
40	51193 U	Oil Tube, for feed crank link-----	1
41	258 A	Nut-----	1
42	52944 T	Looper Rocker Shaft Bushing, left-----	1
43	52944 U	Looper Rocker Shaft Bushing, right-----	1
44	52894 AK	Oil Tube, for looper rocker ball joint, left-----	1
45	22560 B	Screw-----	1
46	51493 BK	Lint Filter Screen-----	1
47	50-648 Blk.	Lucite Oil Gauge-----	1
*	51294 M	Oil Tube, for Style 51100 BM-----	1
*	666-214	Felt Lint Filter-----	1
*	51294 Z	Oil Tube Connection, for Style 51100 BM-----	1
*	21212	Locking Ring-----	1
*	22729 A	Screw, for No. 51294 U, for Style 51100 BM-----	1
*	51294 U	Oil Siphon Assembly, for Style 51100 BM-----	1
*	22729 B	Screw-----	1
*	51294 K	Clamp, upper-----	1
*	666-201	Felt Plug, 5/8 inch long-----	1
*	666-209	Felt Plug, 3/32 inch long-----	1

\* Not shown on picture plate.

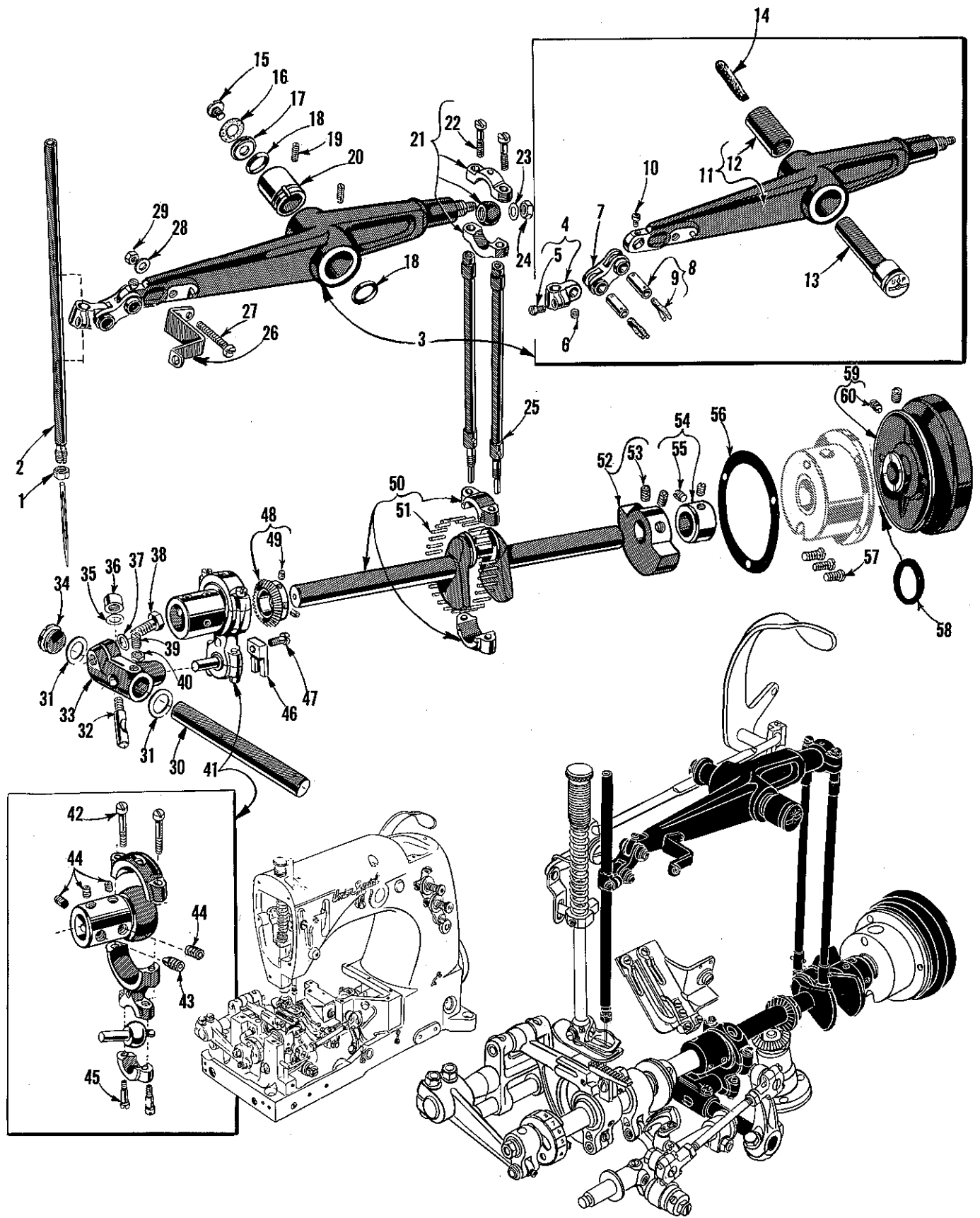

CRANKSHAFT, NEEDLE LEVER AND LOOPER DRIVING PARTS  
FOR STYLE 51100 BM

Ref. No.	Part No.	Description	Amt. Req.
1	56	Needle Clamp Nut-----	1
2	51217 C	Needle Bar-----	1
3	29348 R	Needle Lever Assembly-----	1
4	51254 J	Needle Bar Connection-----	1
5	22562 A	Screw-----	1
6	22564	Screw, for link pin-----	1
7	56354 A	Needle Bar Link-----	1
8	51054	Link Pin-----	2
9	666-149	Lubricating Felt-----	1
10	77	Screw, for upper link pin-----	1
11	56115	Needle Lever-----	1
12	56350 B	Needle Lever Bushing-----	1
13	56350 A	Needle Lever Stud-----	1
14	666-170	Wick-----	1
15	22586 R	Screw-----	1
16	51250 F	Gasket-----	1
17	51250 D	Washer-----	1
18	660-212	Oil Seal Ring-----	2
19	719	Screw-----	2
20	51150	Needle Lever Thrust Collar-----	1
21	29066 R	Needle Lever Ball Joint-----	1
22	22559 G	Screw-----	2
23	51216 N	Washer-----	1
24	51216 P	Nut-----	1
25	51216 G	Needle Lever Connecting Rod-----	2
26	51158 E	Needle Lever Thread Eyelet-----	1
27	22747 A	Screw-----	1
28	652 D-8	Lock Washer-----	1
29	43443 Q	Nut-----	1
30	51242 P	Looper Drive Lever Shaft-----	1
31	51242 L	Thrust Washer-----	2
32	52841 G	Locking Stud-----	1
33	51242 Y	Looper Drive Lever Rocker-----	1
34	22883 A	Plug Screw, for looper drive lever shaft hole-----	1
35	51242 M	Washer-----	1
36	52841 J	Nut-----	1
37	51242 M	Washer-----	1
38	22852 A	Clamp Screw-----	1
39	81	Spot Screw-----	1
40	12982	Lock Nut-----	1
41	29105 Z	Looper Drive Lever Eccentric Assembly, .308 inch throw-----	1
42	22559 B	Bearing Cap Screw, upper-----	2
43	22894 D	Spot Screw-----	1
44	22894 C	Set Screw-----	4
45	22559 A	Bearing Cap Screw, lower-----	2
46	51243 C	Ball Stud Guide Fork-----	1
47	22729	Screw-----	1
48	51493 BP	Oil Pump Driving Gear-----	1
49	22560 B	Screw-----	2
50	29476 GZ	Crankshaft Assembly-----	1
51	51216 M	Needle Bearing-----	28
52	51247	Counterweight-----	1
53	22894 J	Screw-----	2
54	51147	Thrust Collar-----	1
55	95	Screw-----	2
56	56390 E	Crankshaft Bushing Housing Gasket-----	1
57	22569 B	Screw-----	3
58	660-202	"O" Ring, for pulley-----	1
59	51221 C	Handwheel, for No. 1 "V" or round belt-----	1
60	22894 F	Screw-----	2

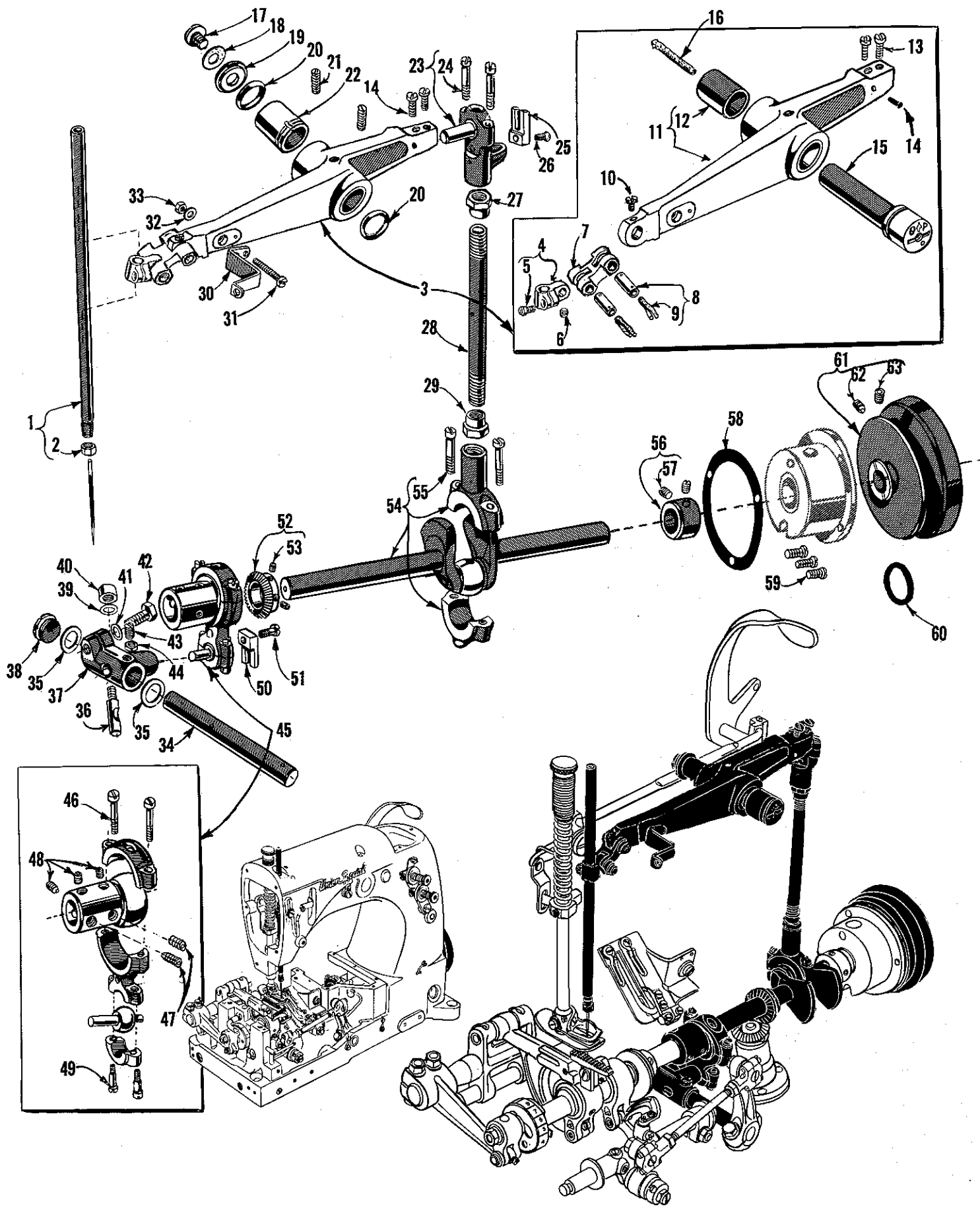

CRANKSHAFT, NEEDLE LEVER AND LOOPER DRIVING PARTS FOR STYLE 51100 BP

Ref. No.	Part No.	Description	Amt. Req.
1	51117	Needle Bar-----	1
2	39151	Clamp Nut-----	1
3	29348 D	Needle Lever Assembly-----	1
4	51254 J	Needle Bar Connection-----	1
5	22562 A	Screw-----	1
6	22564	Screw, for link pin-----	1
7	56354 A	Needle Bar Link-----	1
8	51054	Link Pin-----	2
9	666-149	Lubricating Felt-----	1
10	77	Screw-----	1
11	51115 B	Needle Lever-----	1
12	51250 A	Bushing-----	1
13	93 A	Screw-----	2
14	660-203	Rivet-----	1
15	51250 E	Needle Lever Stud-----	1
16	666-170	Wick-----	1
17	22586 R	Screw-----	1
18	51250 F	Gasket-----	1
19	51250 D	Washer-----	1
20	660-212	Oil Seal Ring-----	2
21	719	Screw-----	2
22	51150	Needle Lever Thrust Collar-----	1
23	29066 N	Needle Lever Connecting Rod Assembly-----	1
24	97 A	Screw-----	2
25	51243 C	Ball Stud Guide Fork-----	1
26	22729	Screw-----	1
27	15430 C	Nut, left hand thread-----	1
28	51216	Needle Lever Connection Rod Tube-----	1
29	15430 D	Nut, right hand thread-----	1
30	51158 E	Needle Lever Thread Eyelet-----	1
31	22747 A	Screw-----	1
32	652 D-8	Lock Washer-----	1
33	43443 Q	Nut-----	1
34	51242 P	Looper Drive Lever Shaft-----	1
35	51242 L	Thrust Washer-----	2
36	52841 G	Locking Stud-----	1
37	51242 Y	Looper Drive Lever Rocker-----	1
38	22883 A	Plug Screw, for looper drive lever shaft hole-----	1
39	51242 M	Washer-----	1
40	52841 J	Nut-----	1
41	51242 M	Washer-----	1
42	22852 A	Clamp Screw-----	1
43	81	Spot Screw-----	1
44	12982	Lock Nut-----	1
45	29105 Q	Looper Drive Eccentric Assembly-----	1
46	22559 B	Bearing Cap Screw, upper-----	2
47	22894 D	Spot Screw-----	2
48	22894 C	Set Screw-----	3
49	22559 A	Bearing Cap Screw, lower-----	2
50	51243 C	Ball Stud Guide Fork-----	1
51	22729	Screw-----	1
52	51493 BP	Oil Pump Driving Gear-----	1
53	22560 B	Screw-----	2
54	29476 DT	Crankshaft Assembly-----	1
55	22559 E	Screw-----	2
56	51147	Thrust Collar-----	1
57	95	Screw-----	2
58	56390 E	Crankshaft Bushing Housing Gasket-----	1
59	22569 B	Screw-----	3
60	660-202	"O" Ring, for pulley-----	1
61	52921 B	Handwheel, for #1 "V" or round belt-----	1
-	51321 G	Handwheel, for #2 "V" belt-----	1
62	22894 H	Spot Screw, for pulley No. 51321 G-----	1
*-	HA81	Spot Screw, for pulley No. 52921 B-----	1
63	22894 E	Set Screw, for pulley No. 51321 G-----	1
*-	HA95	Set Screw, for pulley No. 52921 B-----	1

\* Not furnished with No. 52921 B.

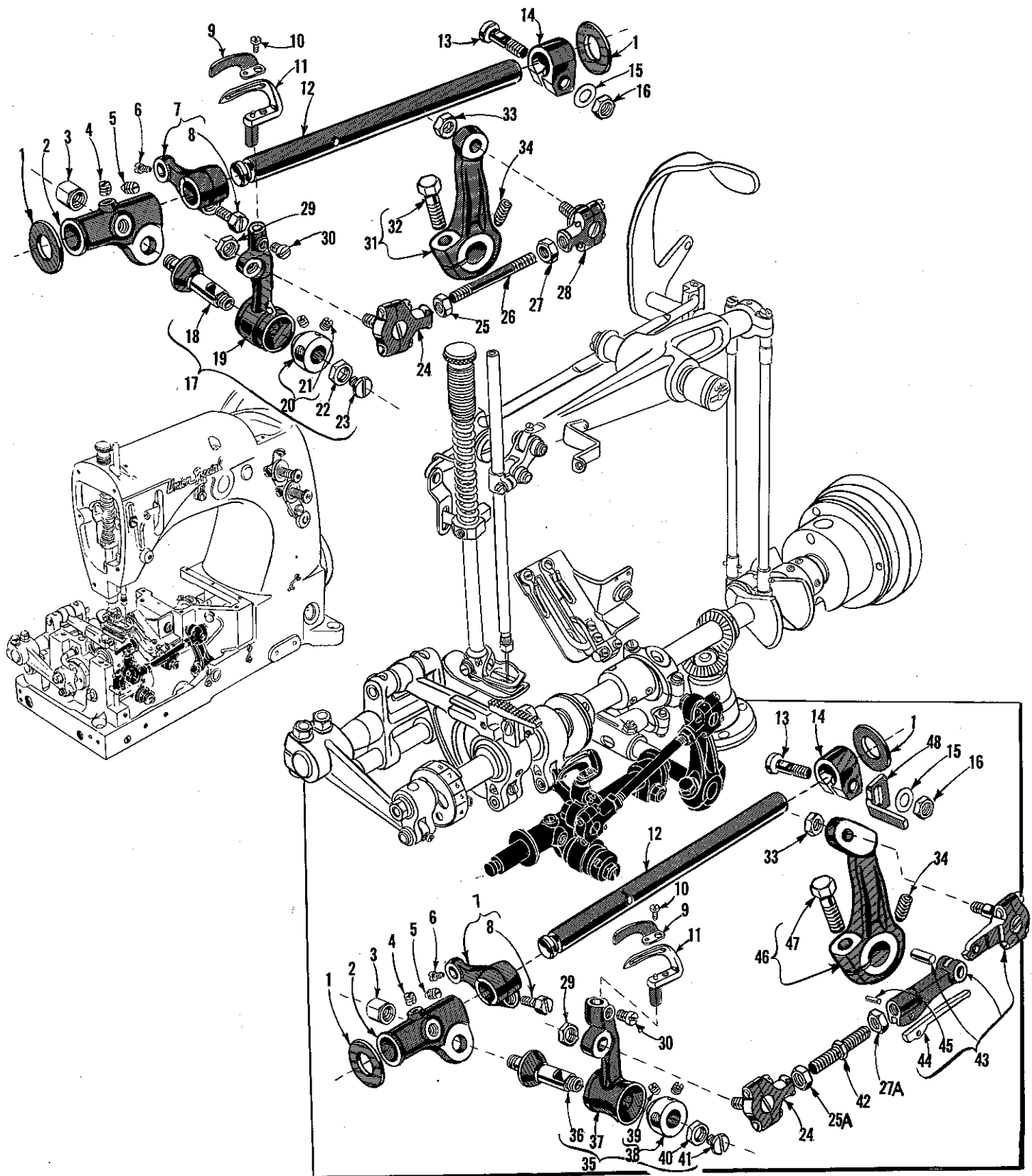



LOOPER ROCKER AND CONNECTING ROD PARTS

<u>Ref. No.</u>	<u>Part No.</u>	<u>Description</u>	<u>Amt. Req.</u>
1	51244 L	Thrust Washer-----	2
2	51244	Looper Rocker Frame-----	1
3	51246	Looper Rocker Stud Nut-----	1
4	98	Set Screw-----	1
5	96	Spot Screw-----	1
6	22768	Screw-----	1
7	51244 B	Looper Rocker Shaft Arm-----	1
8	22519 H	Screw-----	1
9	51110 D	Looper Needle Guard-----	1
10	73 A	Screw-----	1
11	51108 DA	Looper-----	1
12	51144	Looper Rocker Shaft-----	1
13	55244 G	Locking Stud-----	1
14	51244 N	Looper Rocker Shaft Clamp Collar-----	1
15	51216 N	Washer-----	1
16	18	Nut-----	1
17	29192	Looper Rocker Assembly, for Style 51100 BM-----	1
18	51745	Looper Rocker Cone Stud-----	1
19	51213	Looper Rocker-----	1
20	15465 F	Looper Rocker Cone-----	1
21	88	Screw-----	2
22	258 A	Lock Nut-----	1
23	22829	Screw-----	1
24	55241 N	Looper Connecting Rod Ball Joint, left-----	1
25	269	Nut, left thread, for Style 51100 BM-----	1
25A	43242 P	Nut, left thread, for Style 51100 BP-----	1
26	51141	Looper Connecting Rod, for Style 51100 BM-----	1
27	18	Nut, right thread, for Style 51100 BM-----	1
27A	15037 A	Nut, right thread, for Style 51100 BP-----	1
28	51741 C	Looper Connecting Rod Ball Joint, right, for Style 51100 BM-----	1
29	18	Nut-----	1
30	73	Looper Set Screw-----	1
31	51242 W	Looper Drive Lever, for Style 51100 BM-----	1
32	22811 B	Screw-----	1
33	12538	Nut-----	1
34	22894 H	Screw-----	1
35	29192 L	Looper Rocker Assembly, for Style 51100 BP-----	1
36	51745	Looper Rocker Cone Stud-----	1
37	51113	Looper Rocker-----	1
38	15465 F	Looper Rocker Cone-----	1
39	88	Screw-----	2
40	258 A	Lock Nut-----	1
41	22829	Screw-----	1
42	59348 C	Looper Connecting Rod, for Style 51100 BP-----	1
43	51241 K	Looper Connecting Rod and Ball Joint, right, for Style 51100 BP-----	1
44	56341 G	Spring-----	1
45	50-458 Blk.	Spring Pin-----	1
46	52742 H	Looper Drive Lever, for Style 51100 BP-----	1
47	22811 B	Screw-----	1
48	52470	Stop, for looper connection rod, for Style 51100 BP-----	1

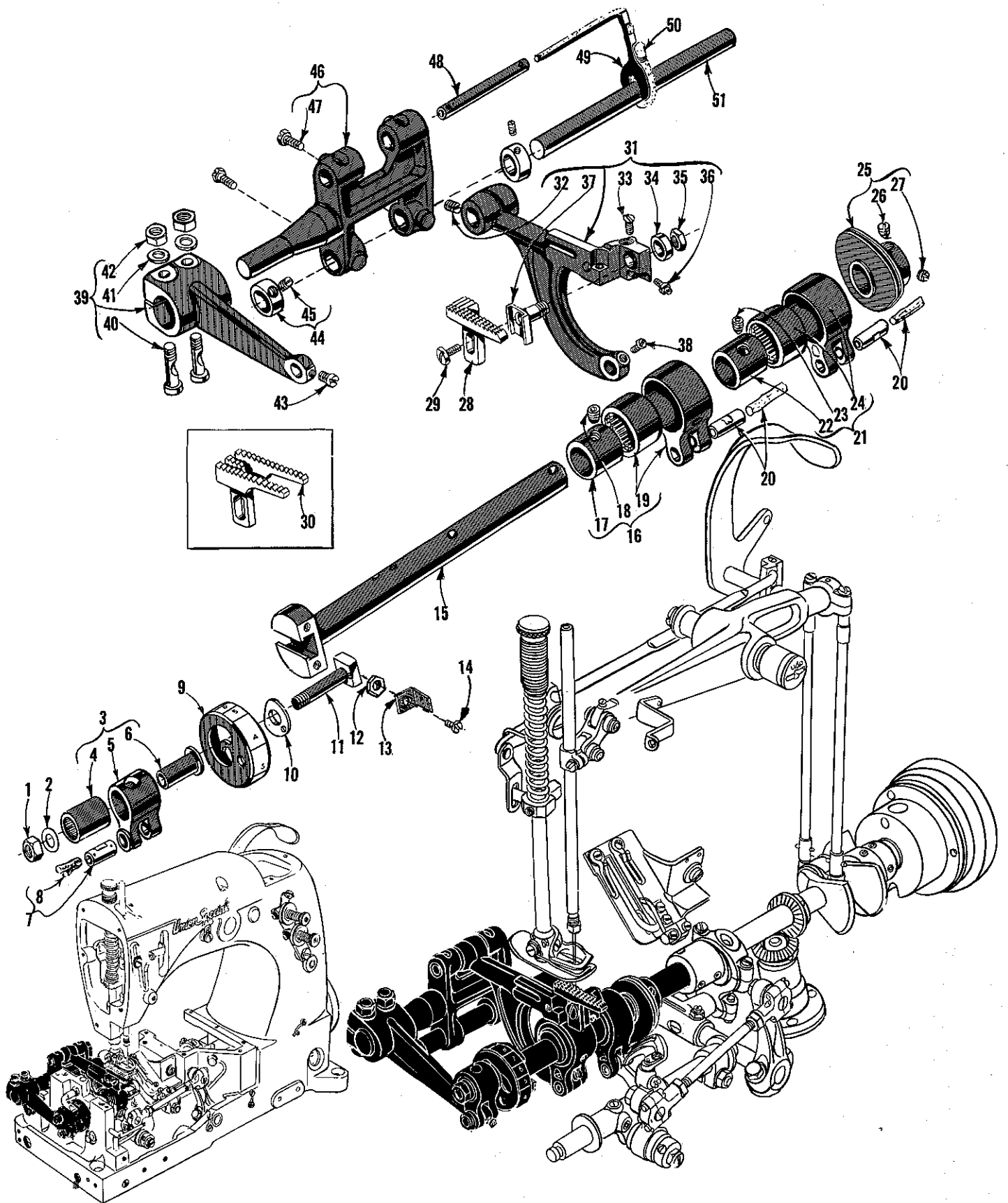

MAIN SHAFT AND FEED DRIVING PARTS

<u>Ref. No.</u>	<u>Part No.</u>	<u>Description</u>	<u>Amt. Req.</u>
1	269	Nut, left thread -----	1
2	20	Washer-----	1
3	51236 E	Feed Crank Link Assembly-----	1
4	660-169	Needle Bearing-----	1
5	51236 D	Feed Crank Link -----	1
6	51236 F	Ferrule -----	1
7	51054	Feed Crank Pin -----	1
8	666-149	Wick-----	1
9	51185 D	Stitch Regulator End Cap-----	1
10	51136	Washer-----	1
11	51136 F	Feed Crank Stud-----	1
12	907	Nut -----	1
13	51186 E	Stitch Regulator Indicator -----	1
14	22562	Screw -----	1
15	51222	Main Shaft -----	1
16	29476 DP	Feed Lift Eccentric Assembly, .140 inch throw-----	1
17	51142 B	Feed Lift Eccentric-----	1
18	22894 D	Screw -----	1
19	51145 A	Eccentric Bearing -----	1
20	51236 A	Link Pin (includes wick)-----	2
21	29476 DR	Looper Avoid Eccentric Assembly, .080 inch throw, for Style 51100 BM -----	1
22	51142 C	Looper Avoid Eccentric -----	1
23	22894 D	Screw -----	1
24	51145 A	Eccentric Bearing -----	1
21	29476 DS	Looper Avoid Eccentric Assembly, .096 inch throw, for Style 51100 BP-----	1
22	51142 E	Looper Avoid Eccentric -----	1
23	22894 D	Screw -----	1
24	51145 A	Eccentric Bearing -----	1
25	51123 G	Looper Thread Take-up -----	1
26	96	Spot Screw-----	1
27	22580 D	Screw -----	1
28	51105 G	Feed Dog, for Style 51100 BM -----	1
29	22528	Screw -----	1
30	6605 L	Feed Dog, for Style 51100 BP-----	1
31	51134 X	Feed Bar -----	1
32	22560 B	Screw -----	1
33	538	Feed Dog Height Adjusting Screw-----	1
34	6042 A	Feed Dog Holder Washer-----	1
35	258	Nut -----	1
36	22863	Screw -----	1
37	56334 E	Feed Dog Holder -----	1
38	77	Screw -----	1
39	51135 P	Feed Rocker Arm -----	1
40	55235 D	Screw -----	2
41	6042 A	Washer-----	2
42	55235 E	Nut -----	2
43	77	Screw -----	1
44	482	Collar-----	2
45	98	Screw -----	1
46	51135 N	Feed Rocker -----	1
47	92127	Screw -----	2
48	51134 C	Feed Bar Shaft -----	1
49	51134 R	Lubricating Felt Guard-----	1
50	51134 P	Lubricating Felt-----	1
51	8	Feed Rocker Shaft -----	1

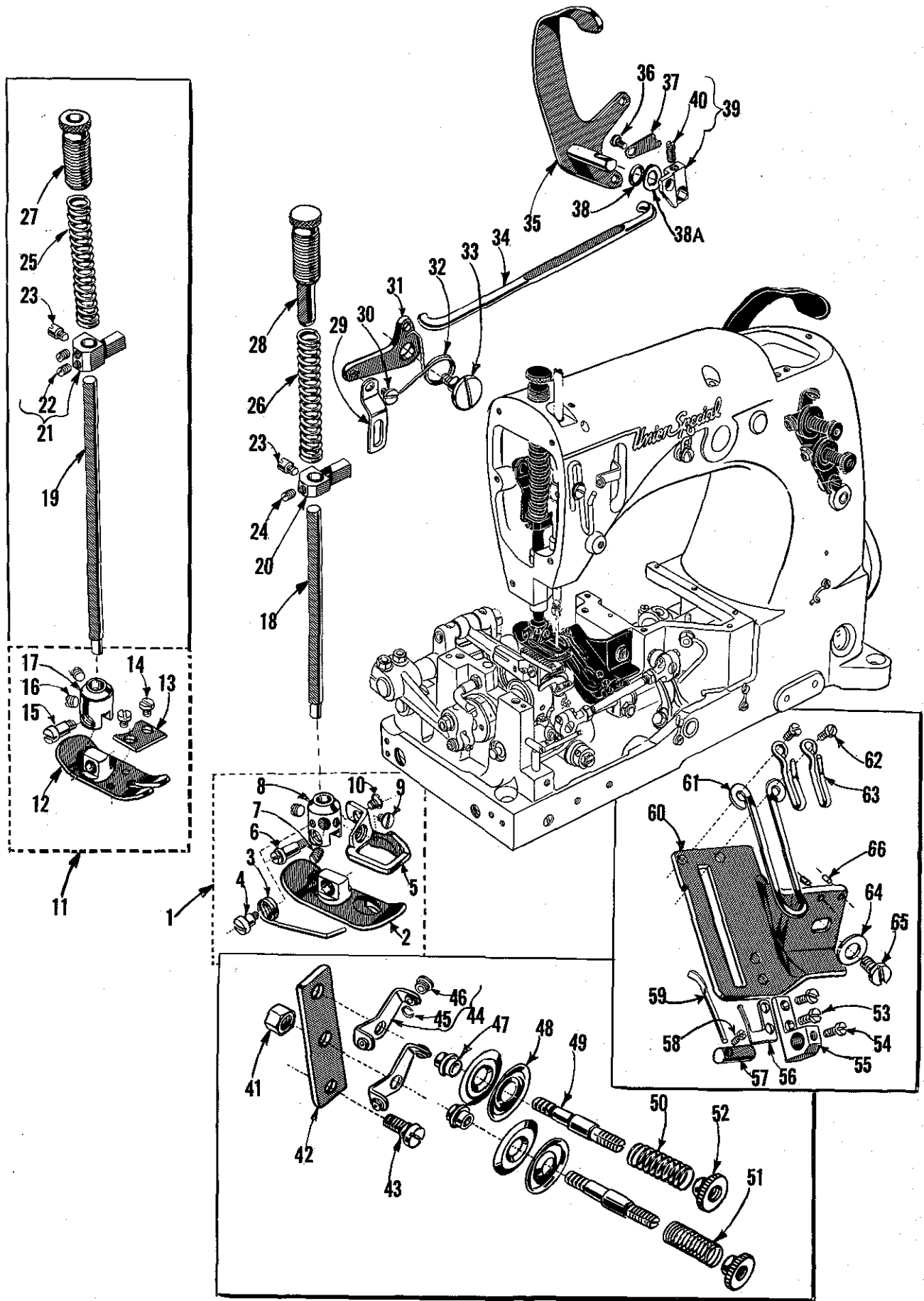

PRESSER FEET, LIFTER LEVER AND THREAD TENSION PARTS

Ref. No.	Part No.	Description	Amt. Req.
1	43120	Presser Foot, for Style 51100 BM -----	1
2	43130	Presser Foot Bottom -----	1
3	15480 C	Spring -----	1
4	57 WD	Screw -----	1
5	43130 B	Finger Guard -----	1
6	22897	Screw -----	1
7	88	Screw -----	2
8	43130 A	Shank -----	1
9	187 A	Screw -----	1
10	22561	Screw -----	1
11	198 X	Presser Foot, for Style 51100 BP -----	1
12	198 XA	Presser Foot Bottom -----	1
13	199	Needle Guard -----	1
14	25 B	Screw -----	2
15	86 X	Screw -----	1
16	88	Screw -----	2
17	65 XD	Shank -----	1
18	51257 K	Presser Bar, for Style 51100 BM -----	1
19	52888 A	Presser Bar, for Style 51100 BP -----	1
20	51257 M	Presser Bar Connection and Guide, for Style 51100 BM -----	1
21	53783 C	Presser Bar Connection and Guide, for Style 51100 BP -----	1
22	22560 B	Screw -----	2
23	402	Screw -----	1
24	531	Screw, for presser bar connection and guide, for Style 51100 BM -----	1
25	53787	Presser Spring, for Style 51100 BP -----	1
26	53787	Presser Spring, for Style 51100 BM -----	1
27	52889 A	Presser Spring Regulator, for Style 51100 BP -----	1
28	56356	Presser Spring Regulator, for Style 51100 BM -----	1
29	53783 A	Lifter Lever Link (402) -----	1
30	22758 C	Screw -----	1
31	53783 L	Presser Foot Lifter Lever Bell Crank -----	1
32	52883 S	Presser Foot Lifter Lever Bell Crank Spring -----	1
33	22557 B	Screw -----	1
34	53783 M	Lifter Lever Connecting Rod -----	1
35	51183 B	Hand and Presser Foot Lifter Lever -----	1
36	22758 C	Screw -----	1
37	51183 C	Lifter Lever Latch -----	1
38	660-207	Oil Seal Ring -----	1
38A	39552 C	Washer -----	1
39	53783 N	Lifter Lever, internal -----	1
40	22537	Screw -----	1
41	43266	Nut -----	1
42	52892	Tension Post Support -----	1
43	22872	Screw -----	1
44	51192 G	Tension Post Eyelet -----	2
45	21114 M	Retaining Ring -----	2
46	668-27	Eyelet -----	2
47	51192 B	Tension Post Ferrule -----	2
48	109	Tension Disc -----	4
49	51292	Tension Post -----	2
50	51292 F-8	Needle Tension Spring, for Style 51100 BM -----	1
	51292 F-14	Needle Tension Spring, for Style 51100 BP -----	1
51	51292 F-2	Looper Tension Spring -----	1
52	51292 C	Tension Nut -----	2
53	J87 J	Screw -----	2
54	77	Screw -----	1
55	51204 C	Auxiliary Cast-off Support -----	1
56	51104 H	Auxiliary Cast-off -----	1
57	51204 A	Cast-off Wire Support -----	1
58	22798 A	Screw -----	1
59	51204	Cast-off Wire -----	1
60	51157 H	Cast-off Wire Support -----	1
61	51104 F	Cast-off Wire -----	1
62	22593	Screw -----	2
63	51158 D	Take-up Eyelet -----	2
64	21657 E	Washer -----	1
65	22528	Screw -----	1
66	50-216 Blk.	Dowel Pin, for No. 51157 H -----	1

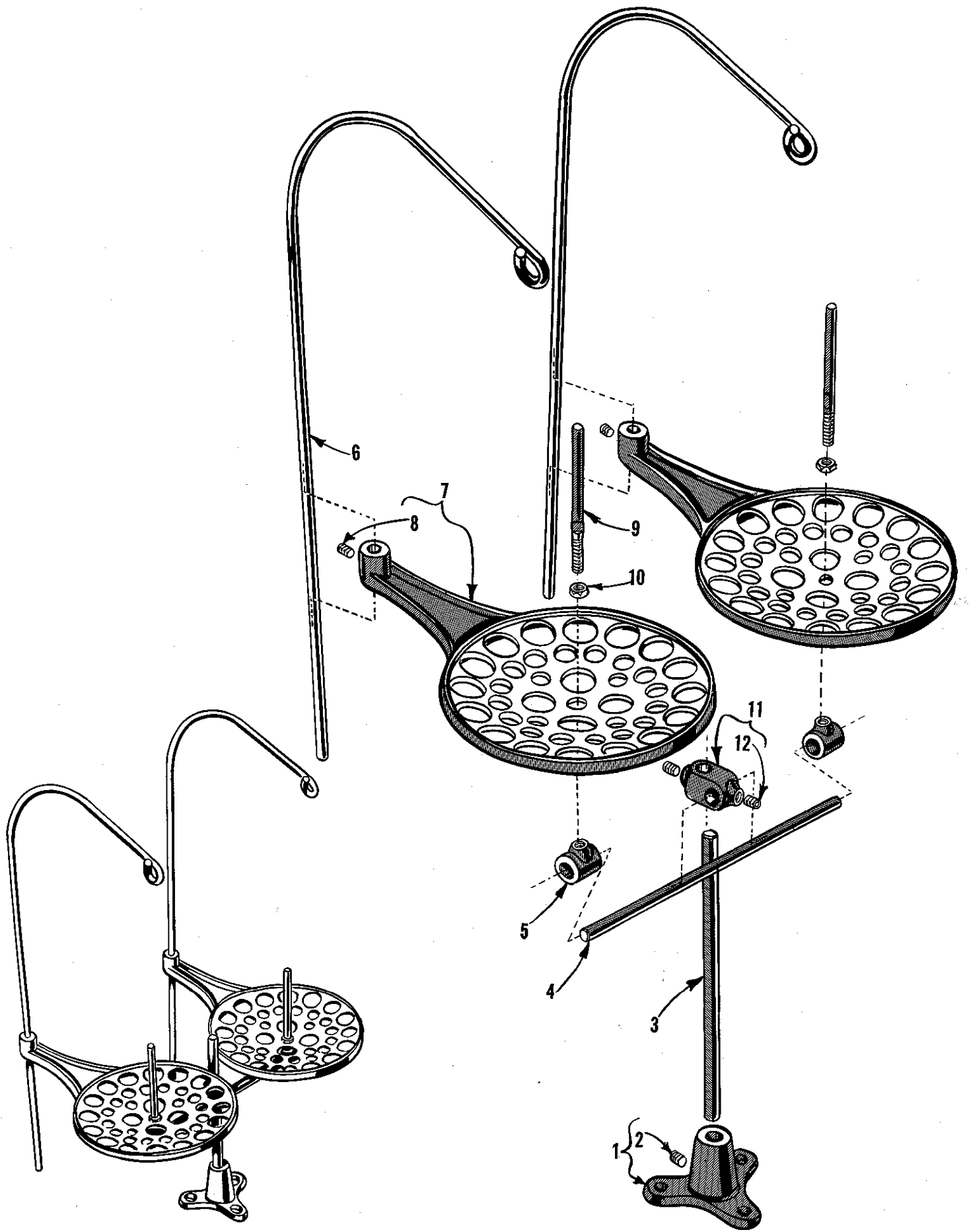

THREAD STAND PARTS

<u>Ref. No.</u>	<u>Part No.</u>	<u>Description</u>	<u>Amt. Req.</u>
1	21114 A	Thread Stand Base-----	1
2	22651 CD-3	Screw-----	1
3	21104 B-9	Thread Stand Rod-----	1
4	21104 B-11	Thread Stand Rod-----	1
5	21104 E	Spool Support Connection-----	2
6	21113 C	Guide Wire-----	2
7	21130 S	Cone Support-----	2
8	22650 CD-4	Screw-----	1
9	21104 G	Spool Pin-----	2
10	21104 H	Nut-----	2
11	21104 C	Rod Connection-----	1
12	22650 CE-6	Screw-----	2

NUMERICAL INDEX OF PARTS

Part No.	Page No.	Part No.	Page No.	Part No.	Page No.
8	19	666-170	13,15	22593	21
18	17	666-179	11	22596	9
20	9, 19	666-201	11	22650 CD-4	23
24 X	9	666-209	11	22650 CE-6	23
25	9	666-214	11	22651 CD-3	23
25 B	21	668-27	21	22711	9
25 D	9	719	13, 15	22729	13, 15
25 S	9	906	9	22729 A	11
50-216 Blk	21	907	19	22729 B	11
50-458 Blk	17	6042 A	11, 19	22733 B	9
50-648 Blk	11	6605 L	19	22747 A	13, 15
50-789 Blk	9	6624 L	9	22758 C	21
52 A	9	7947	9	22760 A	9
		12538	17	22768	17
56	13	12982	13, 15	22798 A	21
57 WD	21	15037 A	17	22799 M	9
65 XD	21	15430 C	15	22811 B	17
73	17	15430 D	15	22823 A	11
73 A	17	15465 F	17	22823 B	11
77	13, 15, 19,	15480 C	21	22829	17
	21	21104 B-9	23	22839	9
80	9	21104 B-11	23	22839 C	9
81	13, 15	21104 C	23	22845 B	9
HA81	15	21104 E	23	22848	9
86 X	21	21104 G	23	22852 A	13, 15
87	9	21104 H	23	22863	19
J87 J	21	21113 C	23	22872	21
88	17, 21	21114 A	23	22883 A	13, 15
90	9, 11	21114 M	21	22889 A	9
93 A	15	21130 S	23	22894 C	13, 15
95	13, 15	21212	11	22894 D	13, 15, 19
HA95	15	21657 E	21	22894 E	15
96	17, 19	21657 X	11	22894 F	13
97 A	15	22513	9	22894 H	15, 17
98	17, 19	22519 H	17	22894 J	13
98 A	9	22524	9	22897	21
109	21	22528	19, 21	29066 N	15
187 A	21	22537	21	29066 R	13
198 X	21	22539 H	11	29105 Q	15
198 XA	21	22541 B	9	29105 Z	13
199	21	22542	9	29192	17
258	19	22548	9	29192 L	17
258 A	11, 17	22557 B	21	29348 D	15
269	17, 19	22559 A	13, 15	29348 R	13
402	21	22559 B	13, 15	29476 DP	19
482	19	22559 E	15	29476 DR	19
531	11, 21	22559 G	13	29476 DS	19
538	19	22560 B	11, 13, 15,	29476 DT	15
539	9		19, 21	29476 GZ	13
643-127 Blk	11	22561	21	35178 D	11
652 D-8	13, 15	22562	19	35731 A	9
660-169	19	22562 A	13, 15	35772 H	9
660-202	13, 15	22564	13, 15	39151	15
660-203	15	22569 B	9, 11, 13,	39552 C	21
660-207	21		15	39582 L	9
660-212	13, 15	22570 A	9	41394 A	9
666-65	11	22571 A	11	43120	21
666-111	11	22580 D	19	43130	21
666-114	11	22584	9	43130 A	21
666-149	13, 15, 19	22585 A	9	43130 B	21
		22586 R	13, 15		



NUMERICAL INDEX OF PARTS

Part No.	Page No.	Part No.	Page No.	Part No.	Page No.
43242 P	17	51236 A	19	51493 BH	11
43266	21	51236 D	19	51493 BJ	11
43443 Q	13, 15	51236 E	19	51493 BK	11
51054	13, 15, 19	51236 F	19	51493 BP	13, 15
51101 R	9			51493 BQ	11
51104 F	21	51241 K	17	51741 C	17
51104 H	21	51242 L	13, 15	51745	17
51105 G	19	51242 M	13, 15	51758	9
51108 DA	17	51242 P	13, 15	52470	17
51110 D	17	51242 R	11	52742 H	17
51113	17	51242 S	11	52841 G	13, 15
51115 B	15	51242 W	17	52841 J	13, 15
51117	15	51242 Y	13, 15	52882 L	9
51123 G	19	51242 Z	11	52882 M	9
51124 D	9	51243 C	13, 15	52882 P	9
51125 E	9	51244	17	52882 U	9
51134 C	19	51244 B	17	52882 W	9
51134 P	19	51244 L	17	52882 AA	9
51134 R	19	51244 N	17	52882 AC	9
51134 X	19	51246	17	52882 AD	9
51135 N	19	51247	13	52882 AF	9
51135 P	19	51250 A	13, 15	52883 R	11
51136	19	51250 D	13, 15	52883 S	21
51136 F	19	51250 E	15	52885 L	9
51141	17	51250 F	13, 15	52888 A	21
51142 B	19	51254 C	11	52889 A	21
51142 C	19	51254 D	11	52890 C	11
51142 E	19	51254 J	13, 15	52891 B	11
51144	17	51257 K	21	52892	21
51145 A	19	51257 M	21	52894 AB	11
51147	13, 15	51257 AA	11	52894 AK	11
51150	13, 15	51281 T-212	9	52894 AM	11
		51281 T-219	9	52921 B	15
51157 H	21	51281 AC	9	52936	11
51158 D	21	51282 Y	9	52944 T	11
51158 E	13, 15	51282 Z	9	52944 U	11
51170 E	9			53556 C	11
51180 J	9	51282 AE	9	53782 B	9
51182 C	9	51290 T	11	53783 A	21
51182 L	9	51292	21	53783 C	21
51183 B	21	51292 C	21	53783 L	21
51183 C	21	51292 F-2	21	53783 M	21
51185 D	19	51292 F-8	21	53783 N	21
51186 E	19	51292 F-14	21	53787	21
51192 B	21	51294 K	11	55235 D	19
51192 G	21	51294 M	11	55235 E	19
51193 S	11	51294 P	9	55241 N	17
51193 U	11	51294 R	9	55244 G	17
51204	21	51294 U	11	56115	13
51204 A	21	51294 Z	11	56168	9
51204 C	21	51295 A	11	56334 E	19
51213	17	51321 G	15	56341 G	17
51216	15	51382 A	9	56350 A	13
51216 G	13	51482 A	9	56350 B	13
51216 M	13	51493 D	11	56354 A	13, 15
51216 N	13, 17	51493 E	11	56356	21
51216 P	13	51493 AG	11	56390 E	13, 15
51217 C	13	51493 AH	11	57885	9
51221 C	13	51493 AY	11	57885 B	9
51222	19	51493 BG	11	59348 C	17
				92127	19



Helpful, authoritative information on the most efficient types of equipment for making virtually any machine sewed article is available from Union Special Sales Promotion Department. Among the many interesting, illustrated bulletins that are available without obligation are the following:



- No. 240, "Men's, Women's, Children's Footwear"
- No. 249, "Rainwear"
- No. 250, "Men's Dress Shirts"
- No. 251, "Service Shirts and Pants"
- No. 252, "Men's Shorts and Pajamas"
- No. 253, "Overalls, Coveralls, and Dungarees"
- No. 254, "Men's Knit Underwear"
- No. 256, "Knit Outerwear"
- No. 259, "Men's Sports Shirts"
- No. 260, "Work Gloves"
- No. 262, "Cotton, Burlap, Jute, and Multiwall Paper Bags"
- No. 263, "Men's Clothing"
- No. 264, "Men's Women's, Children's Jackets"
- No. 265, "Women's Wear"
- No. 266, "Women's Wear And High Fashion"
- No. 267, "Corsets, Girdles, Brassieres"
- No. 268, "Children's Wear"
- No. 269, "Mattresses, Slip Covers, Furniture Upholstery"
- No. 271, "Awnings, Canopies, Tents, Tarps"
- No. 273, "Curtains & Drapes"
- No. 610, "Klipp-it"
- No. 710, "MCS ForMation Unit"
- No. 730, "MCS Automatic Dual Underfront Shirt Hemmer"
- No. 740, "MCS Automatic Rib-Knit Cuff Machine"
- No. 750, "Fusing Presses"
- No. 1100, "Lewis Blindstitch, Chainstitch, Lockstitch, Machines"
- No. 1105, "Button Sewers—Ticket Tackers"
- "Columbia Blindstitch, Saddle Stitch, and Tie Closing Machines"
- No. 1500, "Alteration Department Machines"



**UNION SPECIAL  
CORPORATION**

**HERE ARE HELPFUL  
BULLETINS and CATALOGS  
TO HELP YOU SOLVE  
SEWING PROBLEMS**

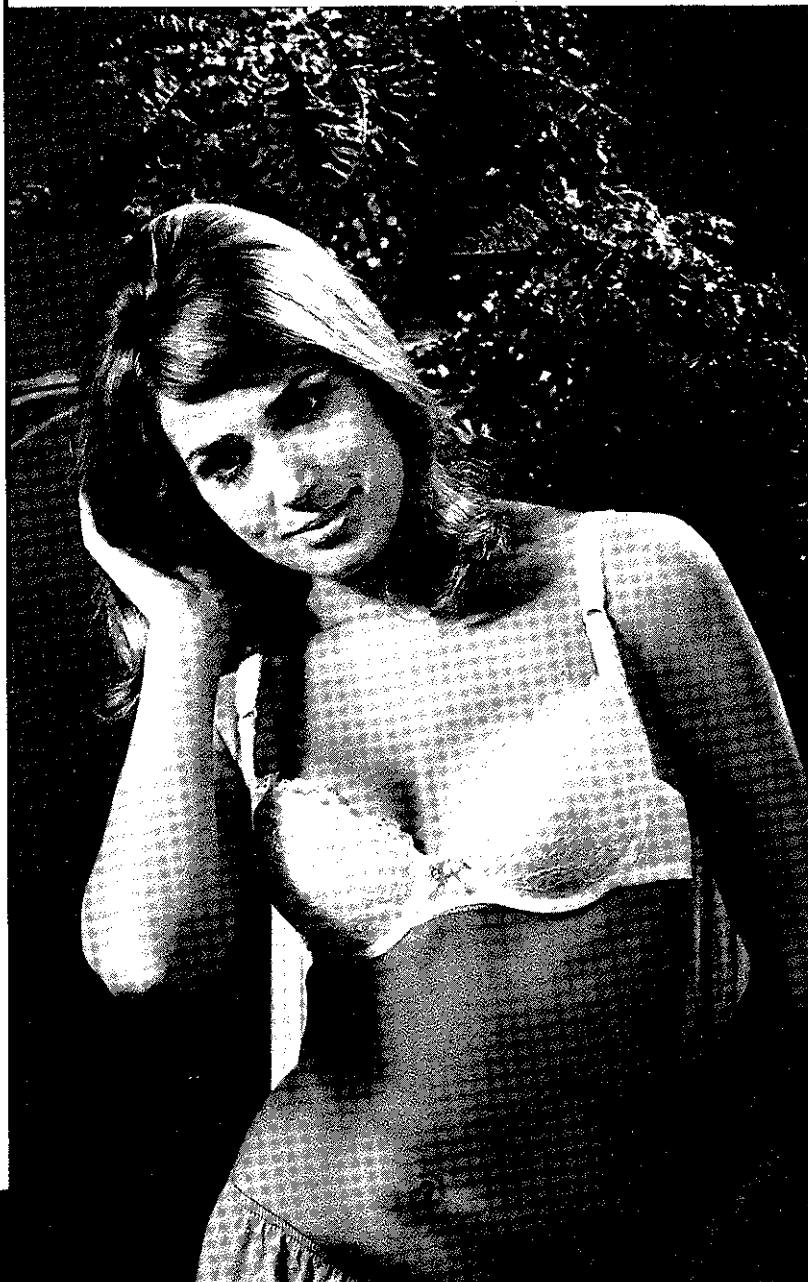



*Union Special*<sup>®</sup>  
INDUSTRIAL SEWING MACHINES

UNION SPECIAL maintains sales and service facilities throughout the world. These offices will aid you in the selection of the right sewing equipment for your particular operation. Union Special representatives and service men are factory trained and are able to serve your needs promptly and efficiently. Whatever your location, there is a Union Special Representative to serve you. Check with him today.

**ATLANTA, GA.**

**BOSTON, MASS.**

**CHICAGO, ILL.**

**DALLAS, TEXAS**

**LOS ANGELES, CAL.**

**NEW YORK, N. Y.**

**PHILADELPHIA, PA.**

**MONTREAL, CANADA**

**TORONTO, CANADA**

**BRUSSELS, BELGIUM**

**LEICESTER, ENGLAND**

**LONDON, ENGLAND**

**PARIS, FRANCE**

**STUTT GART, GERMANY**

Representatives and distributors in all important industrial cities throughout the world.

**UNION SPECIAL CORPORATION**  
**400 N. FRANKLIN ST., CHICAGO, ILL. 60610**