

INSTRUCTIONS AND PARTS BOOK
FOR

Columbia

HIGH SPEED, SINGLE NEEDLE,
PLAIN FEED
LOCKSTITCH MACHINE
MODEL 440-2

MANUFACTURED FOR
AND

DISTRIBUTED BY

Union Special[®]

MACHINE CO.

400N. FRANKLIN STREET

CHICAGO U. S. A.

- INDEX -

Specification	2
Main parts name of machine head	3
I. Preparation for installation of machine	
1. Place of installation of machine	4
2. How to mount the machine head	4
3. How to mount and adjust the knee lifter	5
4. How to mount the motor	6
5. How to connect the motor lever and treadle pedal	6
6. How to mount the bobbin winder assembly	6
II. Preparation for operation	
1. Lubrication	7
2. Precaution before starting to sew	7
3. Shuttle hook lubrication regulator ring	8
4. How to attach the needle	9
5. Selection of thread	9
6. How to thread the upper thread	9
7. How to wind the lower thread on the bobbin	10
8. How to adjust the bobbin winder assembly	10
9. How to place the bobbin into the bobbin case	11
10. How to place the bobbin case into the shuttle hook	12
11. How to remove the bobbin case from the shuttle hook	12
III. How to operate	
1. Start sewing	13
2. Sewing over	13
IV. Stitching adjustment	
1. Adjustment of stitch length	14
2. Adjustment of thread tension	14
3. Adjustment of feed dog height and pressure of presser on materials	16
4. Proper timing between the shuttle hook and needle	18
5. Proper timing between the feed dog and needle	19
V. Cleaning and lubrication	
1. Cleaning	20
2. Replacement of oils	21
VI. Trouble and repairing	22
VII. Parts book	27

INSTRUCTIONS FOR HIGH SPEED INDUSTRIAL SEWING MACHINE

This booklet is a guide to the best use of the high speed industrial sewing machine.

This single needle lock-stitching machine is specially designed at the speed of 5,000 stitches a minute and has the automatic oiling system.

The main parts of this machine is made of special steel.

In this lubricating system, oil is automatically supplied to the main moving parts enabling a continuous operation of the machine at the best efficiency without fear of overheating.

SPECIFICATIONS

Sewing material	General cloths
Speed	5,000 r.p.m.
Needle bar stroke	30.5mm.
Thread take-up	Link motion type
Rotating hook	Full rotation automatic oiling high speed hook
Presser-bar stroke	7.2mm
Lubrication	Full automatic force feed lubrication
Stitch length	0 ~ 4mm.
Stitch length adjustment	Push button type
Reverse sewing	Without
Oil pump	Centrifugal impeller type
Oil tank	Separate from the head
Oil feed back device	Automatic oil feed-back
Lubrication for hook	Adjustable ring type
Knee lift device	Crank type, arm built in
Lubrication oil	White spindle oil

MAIN PARTS NAME OF MACHINE HEAD

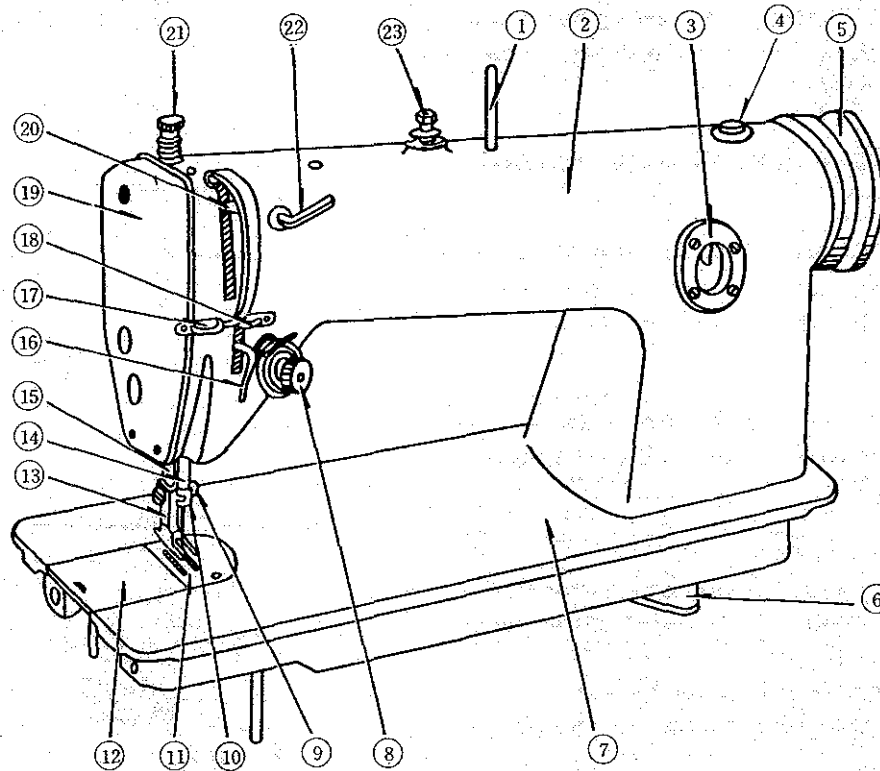

- | | | | | | |
|---|--------------------------------------|----|--------------------------------|----|--------------------------------|
| 1 | Arm spool pin | 8 | Upper thread tension regulator | 16 | Upper thread guide |
| 2 | Arm | 9 | Needle clamping screw | 17 | Thread guide (Face plate) |
| 3 | Oil check window | 10 | Needle bar thread guide | 18 | Thread guide (Arm) |
| 4 | Stitch length regulating push button | 11 | Needle plate | 19 | Face plate |
| 5 | Balance wheel | 12 | Slide plate | 20 | Thread take-up lever |
| 6 | Oil pump | 13 | Presser foot | 21 | Presser regulating thumb screw |
| 7 | Bed | 14 | Needle bar | 22 | 3-hole thread guide |
| | | 15 | Presser bar | 23 | Pre-tension |

Preparation for installation of machine

I. PREPARATION FOR INSTALLATION OF MACHINE.

1. PLACE OF INSTALLATION OF MACHINE.

In order to ensure smooth operation of your machine at high speed without vibration, the machine should be set on well leveled floor.

2. HOW TO MOUNT THE MACHINE HEAD.

1) Cut-out of the table to mount the oil tank

Achieve spot facing of 20mm radius and 17mm depth at the four corners of the table.

Be sure to give smooth facing to the face A where spot facing is achieved.

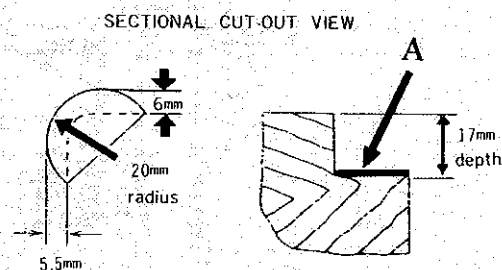

2) Mount the oil tank

- (1) Fit the vibration preventing rubber at the four plate parts of oil tank corners as shown in Fig.
- (2) Fit the oil tank on the table.
- (3) Nail the four corners of the oil tank.
- (4) Fit the U shape gasket onto a groove of inside of oil tank as shown in Fig.
- (5) Mount the knee lifter lifting rod at the part (A) inside of oil tank.

Be sure to fit the vibration preventing rubber properly to provide smooth operation at high speed operation.

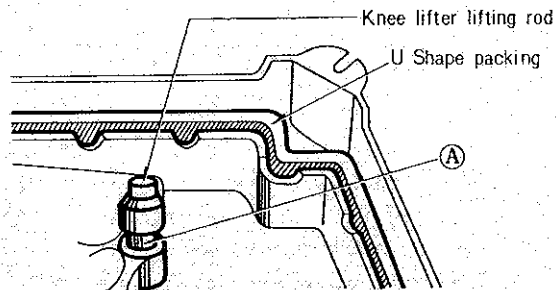
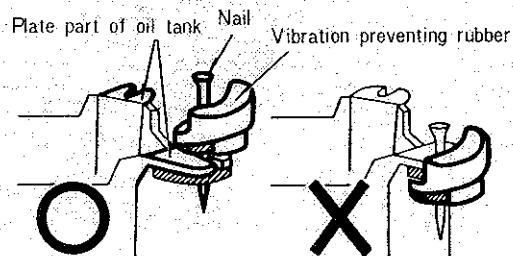

3) Mount the machine head

Insert hinge rod to the hole on the back of the bed and hook on the hinge of the table.

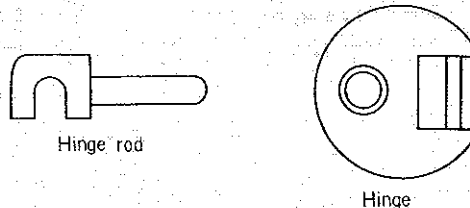

3. HOW TO MOUNT AND ADJUST THE KNEE LIFTER

1) How to mount:

- (1) Place the oil tank on the table.
- (2) Mount the knee plate bar bracket to the end of the knee lifter rock shaft by bolt (A).
- (3) Insert the shorter part of knee plate bar into the hole of knee plate bar bracket and tighten the bolt (B).
- (4) Then tighten the knee plate by bolt (C) as shown in Fig.

- ◆ Place the machine head onto the oil tank on which the knee lifter mechanism is mounted, and move the knee plate to right and left so that the presser foot lifts and down accordingly.
- ◆ Adjustable screw (D)&(E) fixed on the knee lifter rock shaft crank are for purpose of adjustment of the knee lifter operation to be not worked excessively. Please adjust that screws properly.

2) How to adjust:

◆ Screw D :

- (1) Lifts the presser foot by the presser bar lifter fixed on the machine head.
- (2) Move the knee plate of knee lifter mechanism to right so that the presser foot lifts slightly accordingly. Then stop to move the knee plate at the position where the presser bar lifter moves downwards naturally.
- (3) At the same time, adjust the screw (D) so that the tip of screw would come in contact with the oil tank.

◆ Screw E :

- (1) Release the knee plate slowly from right to the former position.
- (2) Stop the knee plate at the position of the presser foot come in contact with the needle plate.
- (3) At the same time, adjust the screw (E) so that the tip of screw would come in contact with the oil tank.

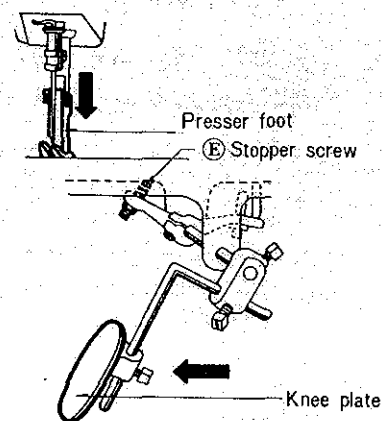
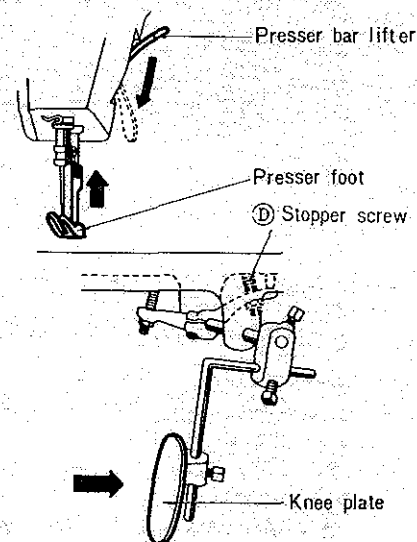
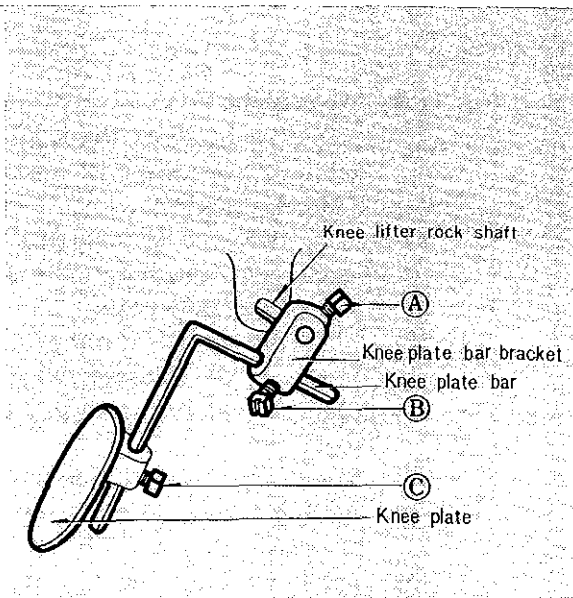

Preparation for installation of machine

◆ Knee plate:

- (1) Mount and adjust the knee plate angle and distance properly according to operators posture.
- (2) The angle can be adjusted loosening the screw (A) and adjust the angle of the knee plate bar bracket.
- (3) The distance between the knee plate and knee can be adjusted moving the knee plate bar to right and left after loosening screw (B).
- (4) The height of knee plate can be adjusted moving the knee plate up and down after loosening screw (C).
- (5) After adjusted, tighten the respective screws(A)(B)and(C).

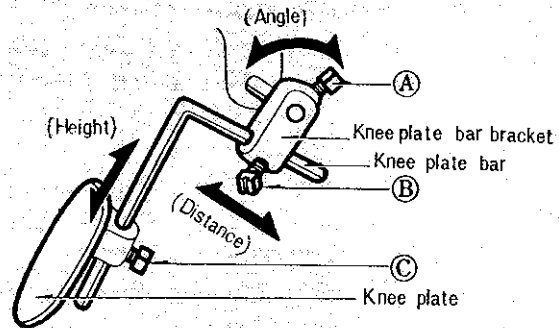

4. HOW TO MOUNT THE MOTOR

- ◆ Motor is mounted with accessory bolts, washer and nuts on a position that enables to pass the belt straight after aligning the balance wheel slot and motor pulley slot.
- ◆ Then connect power supply cord and motor cord extended from switch.

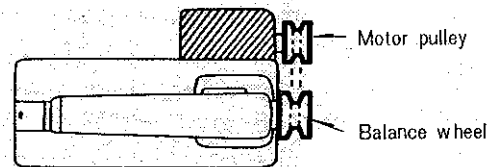

5. HOW TO CONNECT THE MOTOR LEVER AND TREADLE PEDAL

- ◆ Power on the treadle will be reduced if the inclination of treadle is not being proper angle.
- ◆ The best inclination is $30^{\circ} \sim 40^{\circ}$ as shown in Fig.(a).
- ◆ In case of Fig.(b), the treadling gets difficult, therefore, adjust the length of the treadle connecting rod.

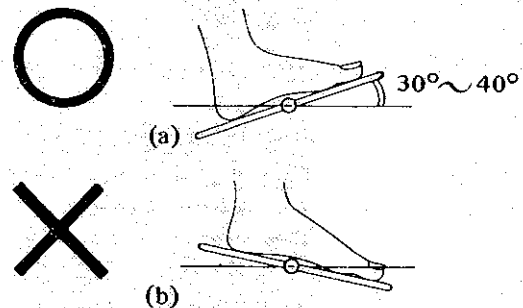

6. HOW TO MOUNT THE BOBBIN WINDER ASSEMBLY

Accessory bobbin winder should be mounted in parallel with belt hole of the table and fixed with 2 screws so that the bobbin winder pulley gets in touch with the belt when the stop latch lever is pushed.

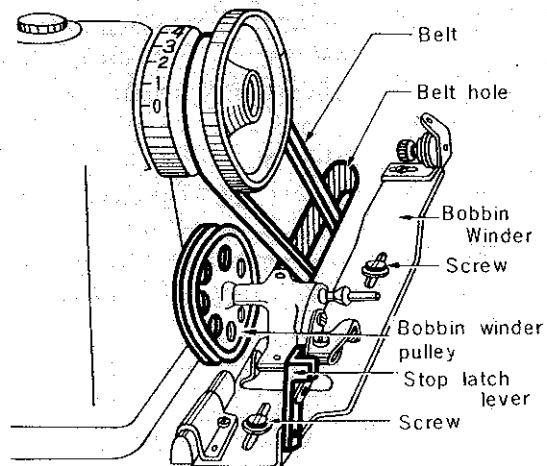

II. PREPARATION FOR OPERATION

1. LUBRICATION

- ◆ You are requested to use the white spindle oil (Red Wood Viscosity 60~90 second at 86°F) by all means.
- ◆ On the oil tank a position marked (A) shows high position of oil volume and the (B) shows low position.
- ◆ Before starting to work, pour oil upto the position (A) by all means.
- ◆ Discharging of oil can be done removing the screw (C).

In case of oil volume would come less than the position B, it causes to not lubricated to respective necessary parts, so be sure to check it twice or three times in a month and replenish sufficiently.

2. PRECAUTION BEFORE STARTING TO SEW

- ◆ This machine is of highly precisioned particularly and assembled.
 - ◆ When starting to sew initially and after kept away for a long time without using at all, it is considered all of the oil lubricated to extremely be insufficient, so that you are advised to lubricate thoroughly before starting operation and try pre-running test according to the following conditions.
- (1) Check up the volume of oil in the oil tank and when it will be less, please replenish oils.
 - (2) Remove the rubber plug (A)~(E) on the arm then lubricate through these holes.
 - (3) Lay down the machine head toward the other side, and turn the hook oil regulating ring then adjust the number of dial into #3.
 - (4) Lubricate thoroughly into the part of feed rock shaft where arrow marked (oil wick).
 - (5) Raise up the machine head as it was.
 - (6) After lubricated, fix the respectiv rubber plug tightly.

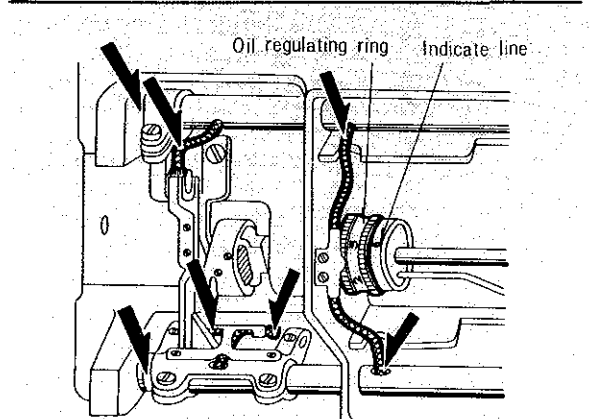
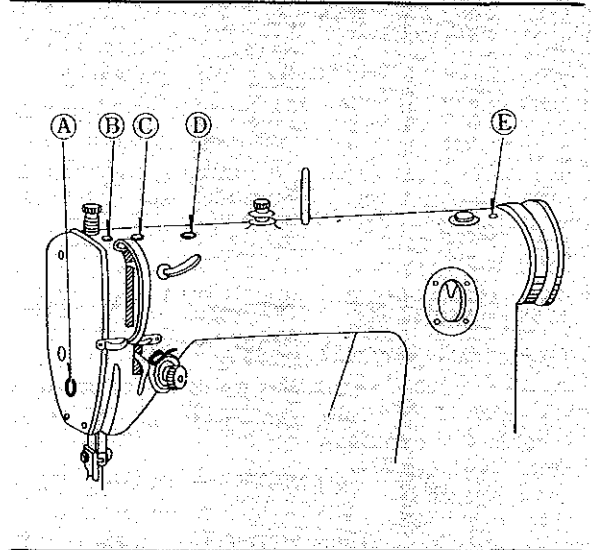
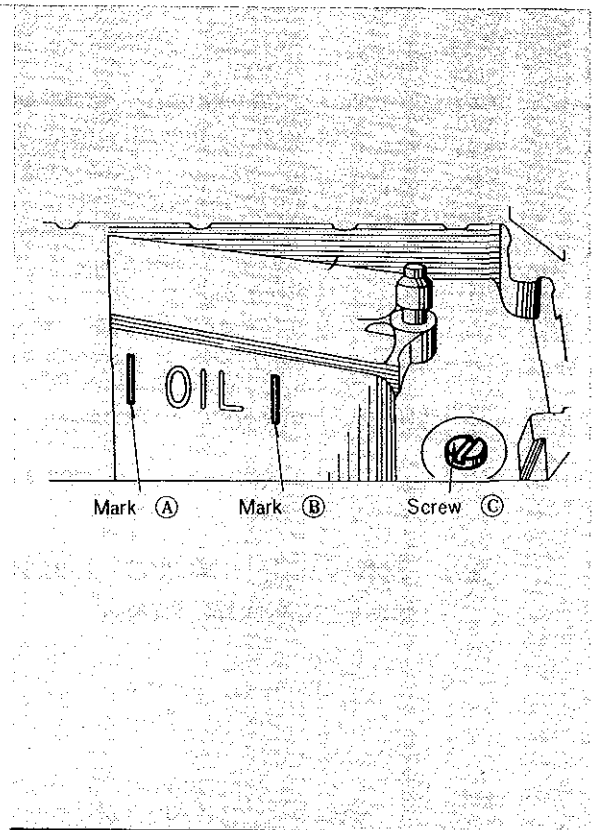

Preparation for operation

- (7) While checking up whether oil flows properly in the oil check window, try sewing test at 2000~2500 r.p.m. by 5~6 times intermittently.
- (8) Try pre-running test at 2500~3000 r.p.m. enabling to penetrate oils into necessity parts thoroughly.
- (9) After pre-running test, adjust the dial #3 of the hook oil regulating ring into the center between #1 and #2.
- (10) Please keep in mind to try operation at 4000 r.p.m. during four weeks from the first time using, and increase the speed gradually.

3. SHUTTLE HOOK LUBRICATION REGULATOR RING

Lubrication to the shuttle hook can be adjusted by means of the shuttle hook lubrication regulating ring at the left on the back of bed.

- (1) Adjust the regulating ring into (0) to minimize the lubrication to the shuttle hook.
- (2) Turn the regulating ring from 1 toward 3 to increase the lubrication volume.
- (3) The regulating ring is usually adjusted in the center between 1 and 2. However, adjust the lubrication volume according to the work appropriately.

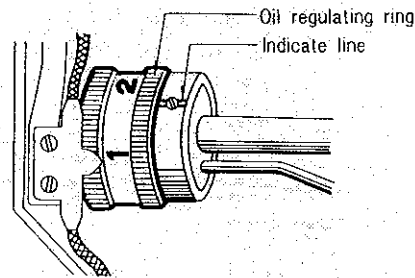
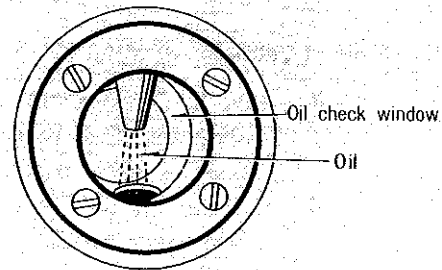

4. HOW TO ATTACH THE NEEDLE

Use 29 - C440 needle

- (1) Turn the balance wheel toward you to raise the needle bar to its highest position.
- (2) Loosen the needle clamping screw.
- (3) Hold the needle so that its side with long groove side toward left, and insert it into the clamping hole being in contact with the needle bar.
- (4) Tighten the clamping screw.

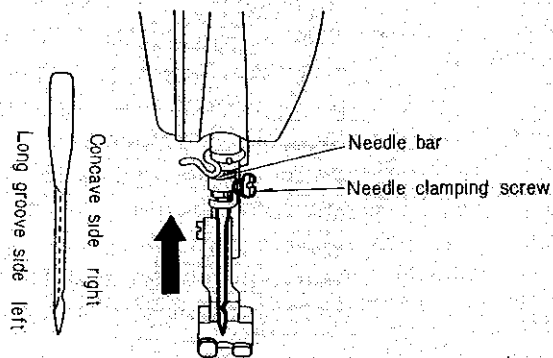

Needle sectional plan



5. SELECTION OF THERAD

- ◆ Always use left-twisted thread for upper thread.
- ◆ In order to check if a thread is right-twisted or left-twisted, hold the thread as shown in Fig. and twist it toward you with your right hand fingers.
- ◆ If the twist is loosen, the thread is right-twisted, while if tightened, it is left-twisted.

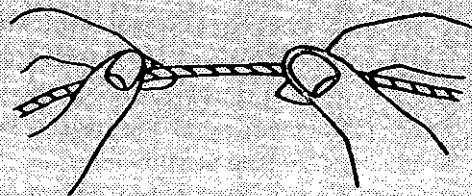

6. HOW TO THREADING THE UPPER THREAD

The upper thread is passed according to the following:

- 1). **Raise the thread take up lever** to its highest position and pass the thread in the order of the numbers shown in Fig.

- | | |
|-------------------------|--------------------------------------|
| 1 Arm spool pin | 8 Take up lever |
| 2 Pre-tension | 9 Thread guide (face plate) |
| 3 3-hole thread guide | 10 Thread guide (needle bar bushing) |
| 4 Thread tension disc | 11 Thread guide (needle bar) |
| 5 Thread take up spring | 12 Needle |
| 6 Upper thread guide | |
| 7 Thread guide (arm) | |

- 2). **The end of thread through the needle hole** is kept in approx. 10cm. pulling down.

- ◆ The arm spool pin 1 with cross-shaped hole, pre-tension 2 and 3-hole thread guide 3 are provided with 3-holes in order to prevent the thread from twisting.

Lead the thread as shown in Fig.

- ◆ The thread tension disc 4 consists of two discs. Lead the thread between these discs from the right to the left.
- ◆ Lead the thread to the thread take up spring 5 from the right to left.
- ◆ Lead the thread to the take-up lever from the right to left.
- ◆ Lead the thread to the needle hole from the left to right.

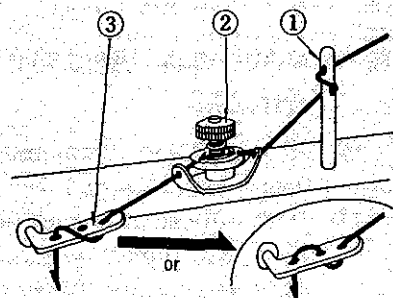
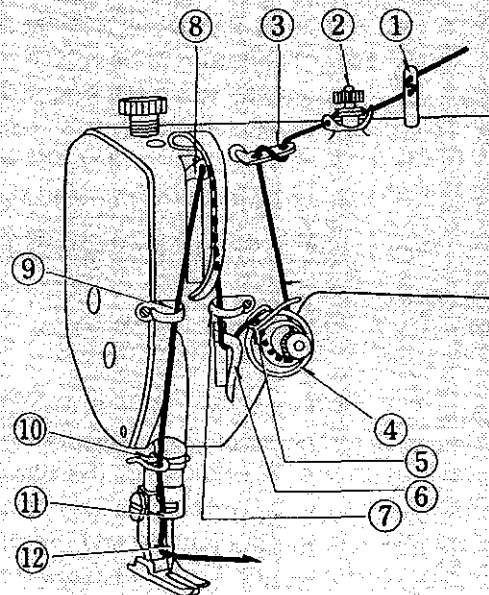

7. HOW TO WIND THE LOWER THREAD ON THE BOBBIN

- (1) Pass the thread from the spool through the hole of the thread guide (1) as shown in Fig. next through the tension discs(2).
- (2) Then wind the thread about 5~6 times on the bobbin.
- (3) Fit the bobbin into the bobbin spindle (3) in such a manner that the thread would be wound on the bobbin from the underside.
- (4) Push the lever toward the other side so that the pulley and the belt will engage.
- (5) Then the bobbin can be wound with thread when the machine is rotated.
- (6) When the bobbin is fully wound with thread, the pulley will automatically be free from the belt and stopped.

This operation can be done while sewing.

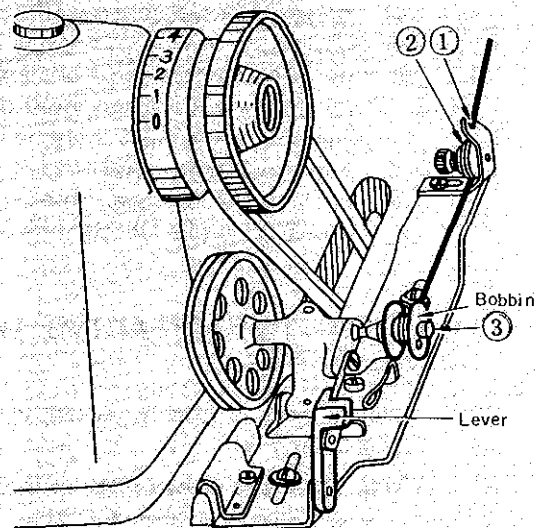

- ◆ When the bobbin would be fitted into the bobbin pin, as shown in Fig. Be careful that the bobbin should forcibly not fitted at the position where the bobbin pin and the slit in the bobbin would be fitted, otherwise, it happens to break the spring.

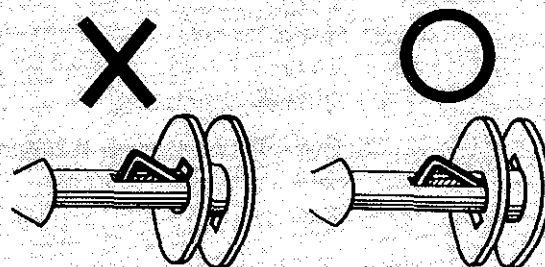

8. HOW TO ADJUST THE BOBBIN WINDER

- ◆ It is desirable that the bobbin is wound evenly with thread as shown in Fig.(A).
- ◆ If the thread is wound unevenly as in (B) & (C), the thread will not be drawn out smoothly and the thread tension will become irregular.

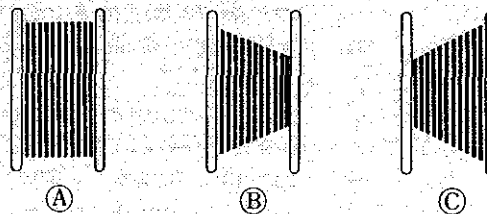

1). In case of uneven winding

- ◆ In case of uneven winding toward the left, loosen the screw (A) of the thread guide, and adjust it moving the thread guide slightly to the right so as to obtain uniform winding of thread.
- ◆ In case of uneven winding toward the right, adjust it moving the thread guide slightly to the left so as to obtain uniform winding of thread.

2). Strength of the winding

- ◆ Particularly in case of nylon thread, there is fear that the bobbin may be damaged if the bobbin is wound too tightly with thread. Adjust with nut(B) shown in Fig.

3). Winding amount of thread

- ◆ Best results are obtained when the bobbin is wound up to 4/5 of its full capacity with thread. Excessive winding will result in poor draw-out of the thread.
- ◆ To adjust the amount of thread wound on the bobbin, turn the screw(C) shown in Fig. to the left when the winding is excessive, and to the right when insufficient.

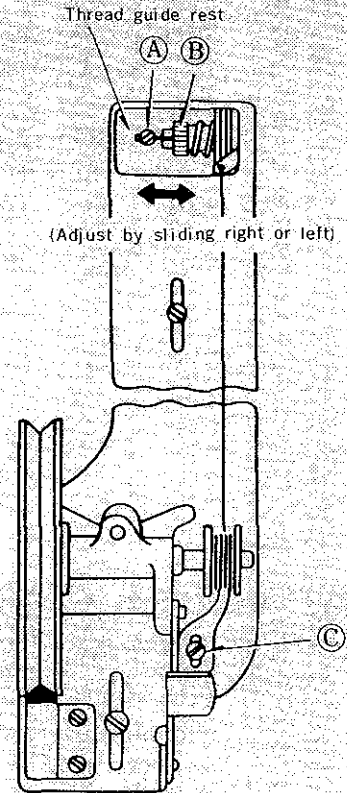

9. HOW TO PLACE THE BOBBIN INTO THE BOBBIN CASE

- (1) Hold the bobbin pulling out the end of thread by abt. 4cm.
- (2) Fit the bobbin into the bobbin case pin.

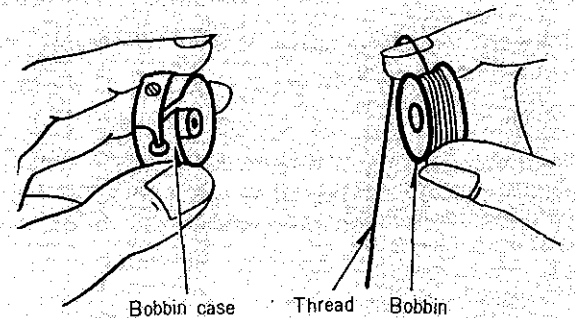

- (3) Lead the end of thread pulled out by about 4cm through the slit in the bobbin case, then underneath the tension spring and the thread guide.

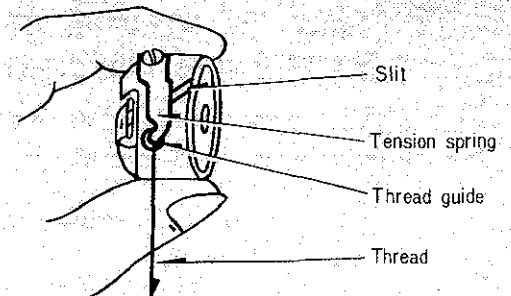

Preparation for operation

- (4) Check up that the bobbin will revolve in clockwise direction and allow the thread to be drawn out as shown by the arrow in Fig.
If the bobbin revolves in the opposite direction, turn the bobbin around and insert.

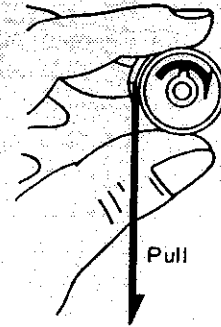

10. HOW TO PLACE THE BOBBIN CASE INTO THE SHUTTLE HOOK

- (1) Lift the needle bar to its highest position, and open the slide plate.
- (2) Grasp the bobbin case with its latch lever fully open, and while holding the cut-away part of the bobbin case upward, insert the bobbin case closely into the hook by fitting the hole of the bobbin case onto pin of the hook.
- (3) Then flap down the latch lever.

* As shown in Fig. if the bobbin case is not placed completely in, and if the machine is operated under such condition it would come out the bobbin case and damage the hook and machine.

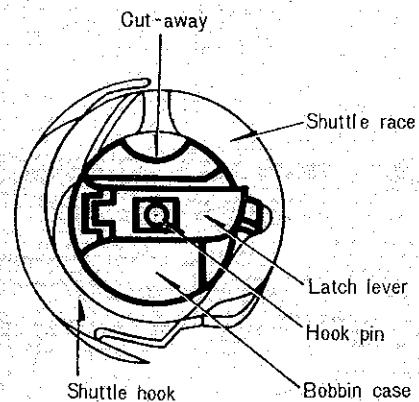

11. HOW TO REMOVE THE BOBBIN CASE FROM THE SHUTTLE HOOK

- (1) Take out bobbin case with the reversed procedure of placing.
- (2) Hold the latch lever and let the bobbin drop out by holding the case with its open side down.

III. HOW TO OPERATE

1. START SEWING

- (1) Lift the presser foot.
- (2) Holding the end of the upper thread by left hand and turn the balance wheel slowly.
- (3) Then the upper thread is led out pulling the lower thread simultaneously through the hole of the needle plate shown in Fig.
- (4) Pull out the lower thread and hold it the other side from the underneath of the presser foot as shown in Fig.
- (5) Put the part of the cloth to start sewing under the needle.
- (6) Turn the balance wheel toward your side so that the needle stitches the cloth.
- (7) Then down the presser foot and start to sew.

When starting to sew, please leave the upper thread pulled out by approx. 10cm in length so as to not to fall out.

Remember that if you start to sew rapidly from the beginning after down the presser foot, the thread happens to cut.

The beginning 4 ~ 5 stitches should be started to sew slowly and then increase the speed gradually.

2. SEWING OVER

- (1) When sewing over the take up lever should be lift at its highest position.
- (2) Lift the presser foot.
- (3) Pull out the sewn fabric diagonally to the other side.
- (4) Trim both of the upper and lower thread.

In case of the take up lever is down, if you will pull out the sewn fabric, it happens the upper thread cut into the hook, cut by itself, bend the needle and damage the hook.

When sewing over, it is recommended that the upper thread pulled out about 10cm length so that next starting to sew is convenient for you.

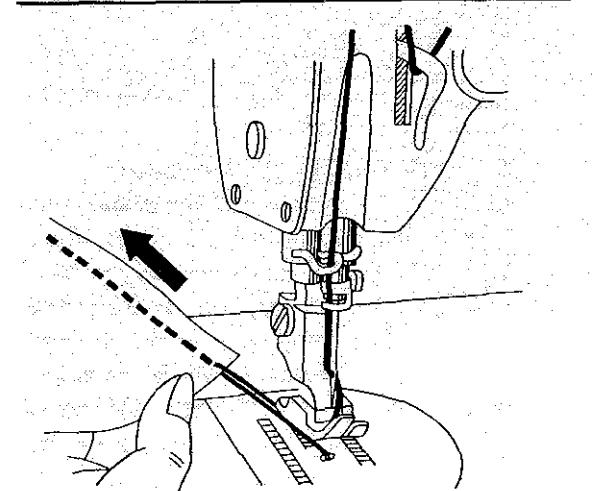
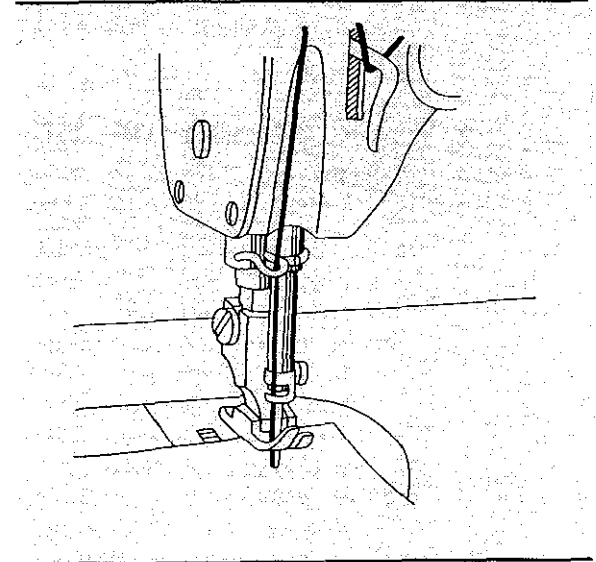
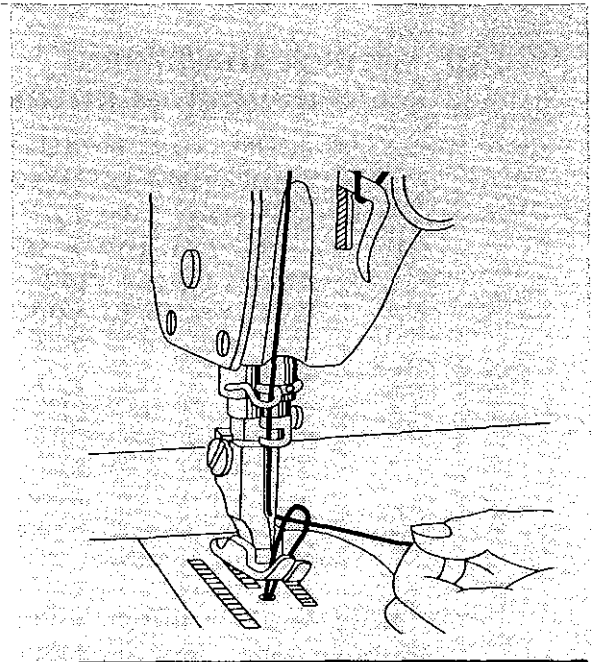

IV. STITCH ADJUSTMENT

1. ADJUSTMENT OF STITCH LENGTH

Stitch length can be adjusted with the stitch regulator push button on the arm and the balance wheel.

- (1) Push the push button down and turn the balance wheel slowly toward you.
- (2) So that the push button goes down further and the balance wheel stops rotation.
- (3) Push the push button down additionally so that the balance wheel rotates. At this time set the graduation (0 – 4) of the dial on the Balance Wheel with the marking on the arm and then release the push button shown in Fig.

Please remember that do not push the push button while the machine is working. This is important to prevent breakage of the machine.

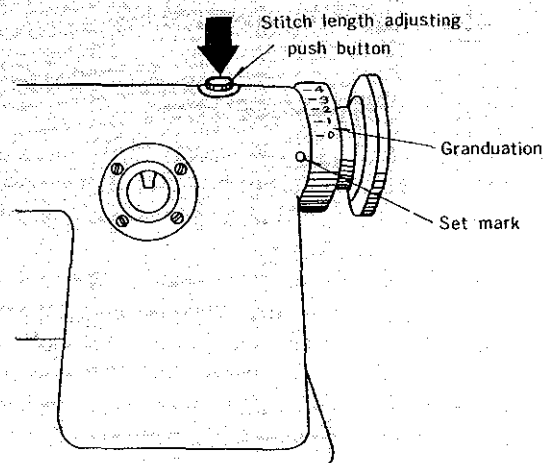

2. ADJUSTMENT OF THREAD TENSION

- ◆ Adjust the thread tension according to the kind of materials sewn, the thread used, the length of the stitches, and other stitching conditions.
- ◆ If the tension of the upper and lower thread are well balanced the two threads will link together in the middle of the fabric to provide perfect, chain-like stitches (A) as shown in Fig.
- ◆ If either the upper or lower thread tension is too tight or too loose it will be imperfect stitches such as (B) & (C) shown in Fig.
- ◆ Fig.(B) is a case of the upper thread is too tight, Fig.(C) is too loose of the upper thread.

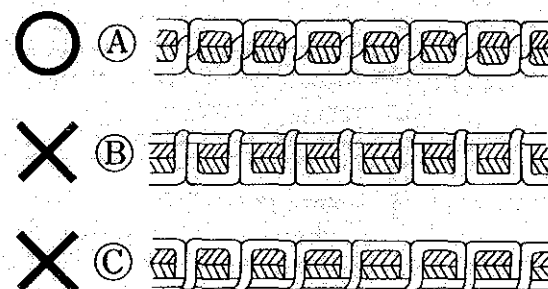

1) Tension of upper thread

Adjustment of the upper thread tension can be achieved by changing the pressure of the thread tension discs of the upper thread tension regulator, as well as the strength and operating range of the thread take-up spring.

(1) Pressure of thread tension discs

- ◆ Ordinarily, the desired tension can be obtained just by adjusting the pressure of the thread tension discs.
- ◆ To strengthen, turn the thread tension nut to the right as shown in Fig.
- ◆ To weaken, turn to the left.

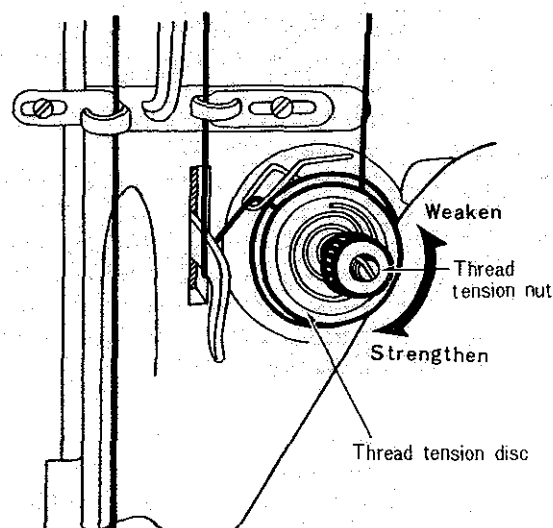

(2) Strength of the thread take up spring

- ◆ Adjust the strength of the thread take up spring according to the materials to be stitched.
- ◆ Standard materials approx. 25g.
- ◆ Light materials (small stitch length), weaken the spring approx. 20g.
- ◆ Heavy, materials (large stitch length), strengthen the spring approx. 30g.
- ◆ **Such adjustment can be done that**
 - (1) Leave lift the presser bar lifter.
 - (2) Remove the face plate.
 - (3) Loosen the screw of the upper thread tension regulator, as shown in Fig.
 - (4) Fit the screw driver into the slit of the thread tension stud and turn the stud to the right to strengthen it, and to the left to weaken it.
 - (5) After adjusted, tighten the screw.

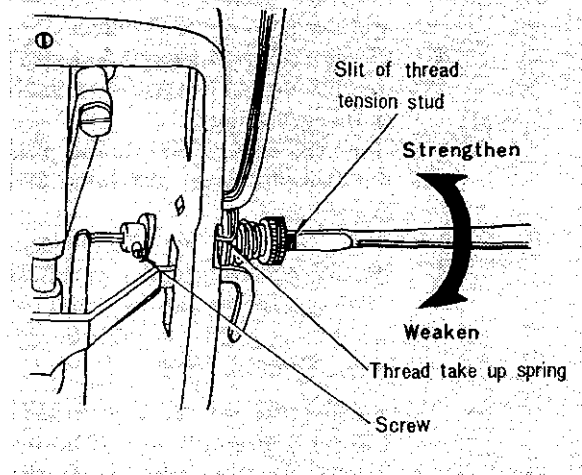

(3) Operating range of the thread take up spring

- ◆ Adjust the strength of the take up spring as well as change operating range of the take up spring enabling to proper working.
- ◆ The operating range can be measured at the interval between the upper thread guide and the thread take-up spring while the presser bar lifter is raised.
- ◆ In case of standard (general fabric) materials approx. 8mm.
- ◆ In case of light (small stitch length) materials, increase the operating range slightly approx. 8mm or up.
- ◆ In case of heavy (large stitch length) materials, decrease the operating range slightly approx. 8mm or less.
- ◆ **Such adjustment can be done as following**
 - (1) Loosen the set screw of the upper thread tension regulator.
 - (2) Fit the screw driver into the slit of the tension regulator stud, and turn the stud to the right to increase the operating range.
 - (3) Turn the stud to the left to decrease the operating range.
 - (4) After adjusted, tighten the screw.

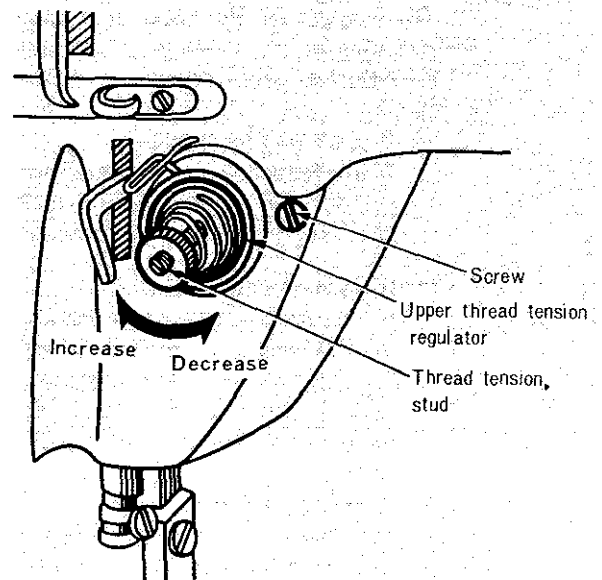
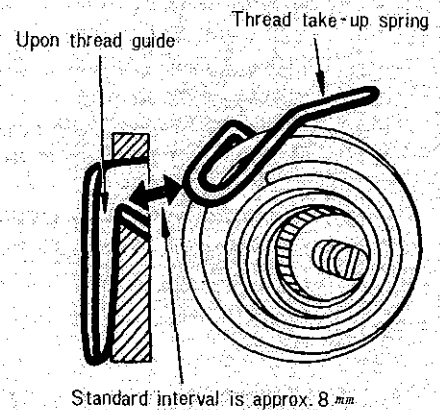

Stitch adjustment

2) Tension of lower thread

- ◆ There is virtually no need to adjust the lower thread tension, except for special kind of fabrics or thread, when slight adjustment will be necessary.
- ◆ In case of the used thread size #50, the regular thread tension can be checked on as the following:
 - (1) Hold the end of the thread pulled out of the bobbin case and hang it as shown in Fig.
 - (2) Give a shake to the thread slightly.
 - (3) On all such occasion, it is the regular tension of the thread that the thread draws out from the bobbin case enough properly (abt. 20g.).
- * Holding the end of the thread only and if the bobbin case would be fallen by its weight, the tension is weak, then strengthen it.
- * In case of the thread would not be drawn out from the bobbin case although giving a shake to the thread, the tension is strong, then weaken it.
- * In case of the thread size is under #40, the tension of thread should be strengthened (abt. 40g.).
- ◆ **Such adjustment can be done as following**
Turn the thread tension screw of bobbin case to the right, to strengthen the tension and to the left to weaken the tension.

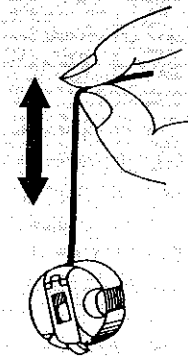

(Abt. 20g)

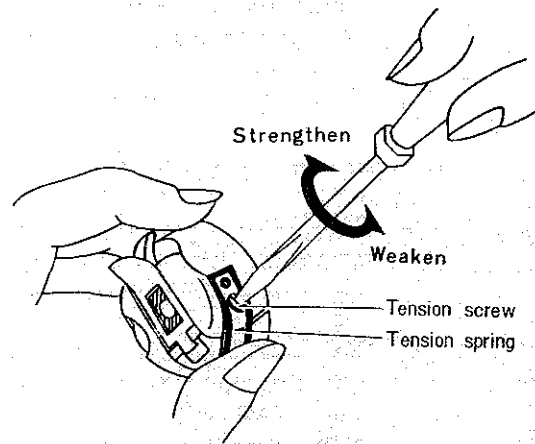

3. ADJUSTMENT OF FEED DOG HEIGHT AND PRESSURE OF THE PRESSER ON MATERIALS

The height of the feed dog as well as the pressure on the sewn material must properly be adjusted according to the materials to be sewn.

- 1) **In case of thin fabrics:**
If the feed dog is raised excessively or the pressure on the materials to be sewn is too strong, shrank sewing will result.
- 2) **In case of heavy fabrics:**
If the feed dog is not raised sufficiently or the pressure on the materials to be sewn is too weak, the feeding of material will become poor, and stitches will become uneven or stitch skipping may result.
- 3) **Feed dog height:**

Thin fabrics	Approx. 0.8mm
Standard fabrics	Approx. 1.0mm
Heavy fabrics	Approx. 1.2mm

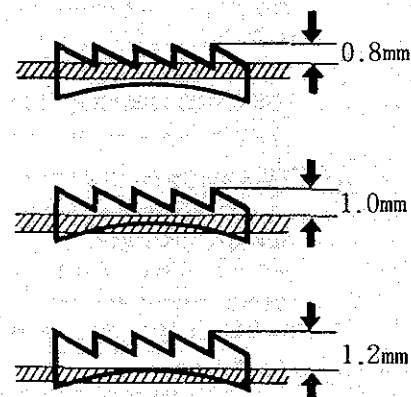

The height of feed dog is measured when the feed dog raised at its highest position from the needle plate turning the balance wheel by hand.

4) Adjustment of feed dog height

- (1) Lay down the machine head toward the other side.
- (2) Turn the balance wheel by hand and stop to turn when the feed dog would be raised to its highest position from the needle plate.
- (3) Loosen the screw of the feed lifting rock shaft crank.
- (4) Adjust the feed dog to the desired height moving the feed lifting rock shaft crank before and behind.
- (5) Tighten the screw of the feed lifting rock shaft crank at the adjusted height of the feed dog.

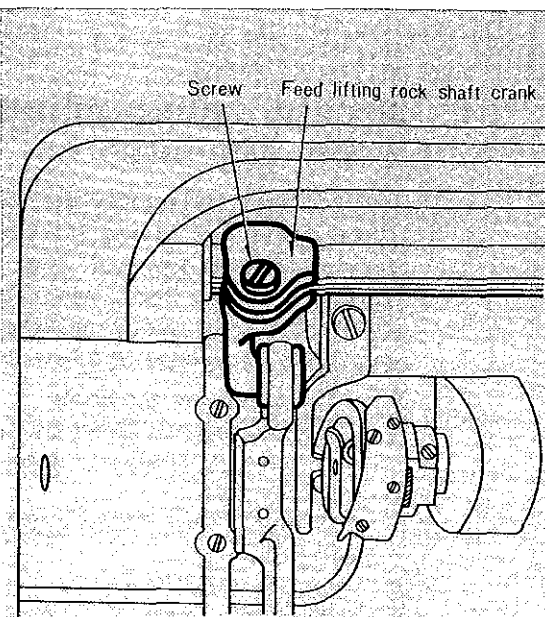

5) Adjustment of pressure of presser foot

- (1) Turn the presser regulating thumb screw to the right to strengthen the pressure of presser foot.
- (2) Turn the presser regulating thumb screw to the left to weaken the pressure of presser foot.

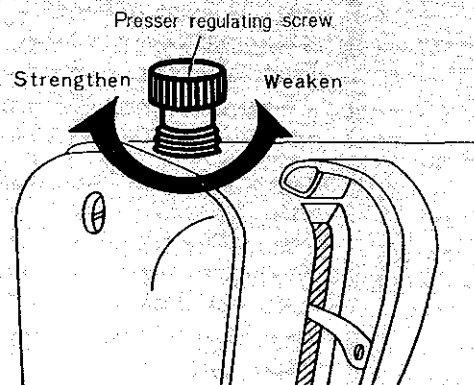

6) Adjustment of presser bar

◆ In case of adjusting the interval between the presser foot and needle plate by moving the presser bar up and down in accordance with the sewing materials, or replacing the presser foot, the hemmer and etc, such adjustment can be done as following:

- (1) Keep lift the presser bar lifter.
- (2) Keep loosen the presser regulating screw.
- (3) Remove the face plate rubber plug (upper)
- (4) Loosen the left screw out of two screws looks throughout the face plate rubber plug hole.
- (5) Adjust the height of presser bar and tighten the screw.
- (6) Place the rubber plug as it was.

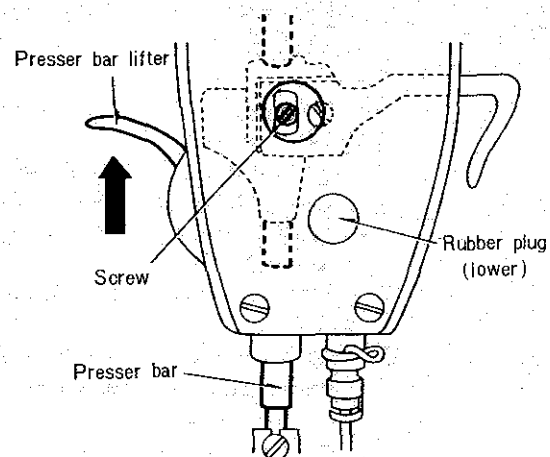

4. PROPER TIMING BETWEEN THE HOOK AND NEEDLE

1) How to place and remove the hook

Place the hook in the position described below in the event of the thread gets entangled in the hook, when its position is changed due to shock or other causes, or when it is replaced with a new one.

◆ How to remove the hook

- (1) Turn the balance wheel by hand and stop it when the needle would be raised to its highest position.
- (2) Lay down the machine head toward the other side.
- (3) Remove the bobbin case.
- (4) Loosen the screw A shown in Fig. and remove the hook stopper.
- (5) Loosen the set screw B of the hook.
- (6) Face the upper part of the hook downward, and remove it to the left side.

◆ How to place the hook

- (1) Place the hook in the way to the contrary how to remove it.
- (2) The position of placing the hook will be proceeded in the following ways.

2) The position of the hook and needle

- (1) Turn the balance wheel with hand so that the needle come to its lowest position.
- (2) At the same time, the center of the needle hole would be in contact with the inner face of the hook as shown in Fig. A.
- (3) Raise the needle by 2.4mm from its lowest position.
- (4) At this time, the tip of hook comes to the center line of the needle (relative position of the hook and needle).

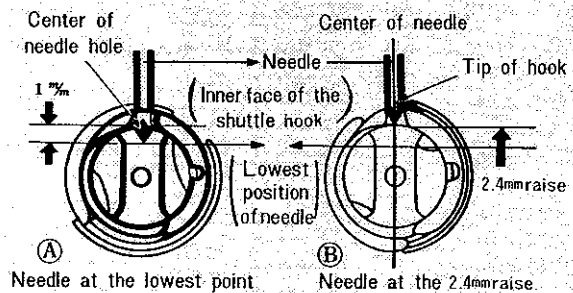
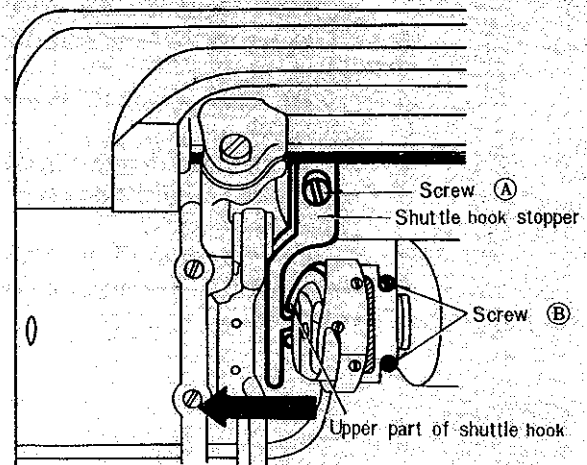

3) Adjustment for the relative position of the hook and needle

◆ In case of the relative position of the hook and needle would not be in good timing, adjust it moving the needle bar up and down.

- (1) Remove the face plate rubber plug (lower).
- (2) Turn the balance wheel looking into the rubber plug hole and stop to turn when the needle bar connecting stud screw comes to the plug hole.
- (3) Loosen the needle bar connecting stud screw, adjust the needle bar position.
- (4) After adjusted, tighten the stud screw.

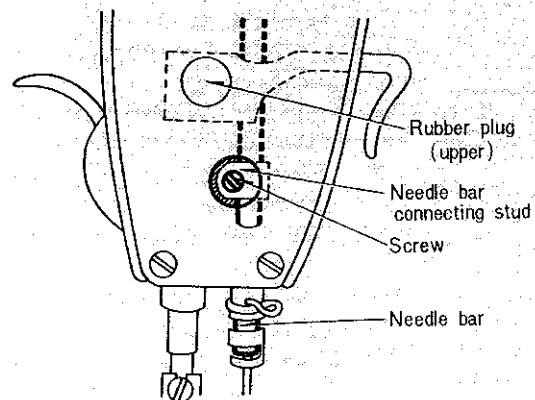

4) The gap between the concave face of the needle and tip of hook

- (1) The gap between the needle and tip of hook would be approximately 0.05mm. as shown in Fig.
- (2) In case of the gap is too wide, adjust it loosening the hook set screws.

The gap between the lateral face of the needle and tip of hook

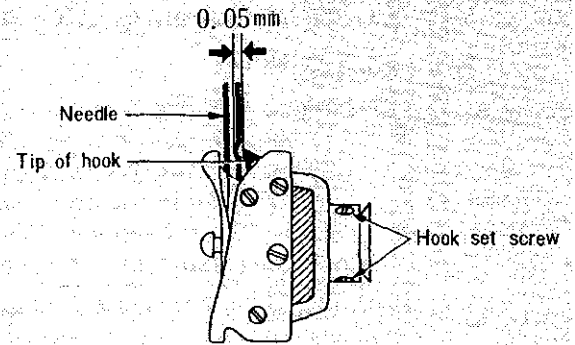

5. PROPER TIMING BETWEEN THE FEED DOG AND NEEDLE

- ◆ The proper timing of the feed dog and needle will be that in which the needle tip would reach the needle plate surface just at the moment the feed dog begins to sink downward the needle plate surface after the material is fed as shown in Fig.

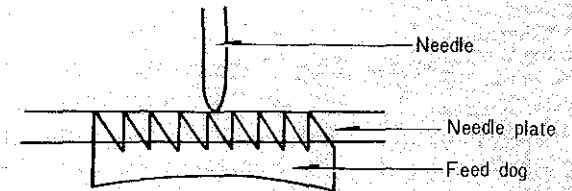

◆ Such adjustment can be done as following

- (1) Remove the arm side cover.
- (2) Loosen the three screws of the feed lifting cam.
- (3) While fixed the feed lifting cam by hand, turn the balance wheel toward your side so that feeding device will be faster.
- (4) In order to slow the feeding device, turn the balance wheel toward the other side.
- (5) After adjusted the feed lifting cam timing, tighten the three screws.
- (6) Loosen the three screws of the feed rock shaft cam.
- (7) Tighten the three screws at the relative position between the feed rock shaft and feed lifting cam would be as shown in Fig.

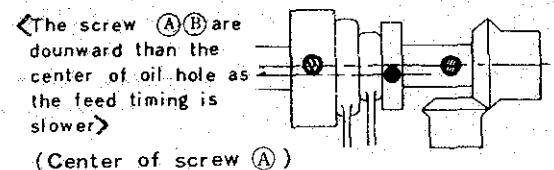
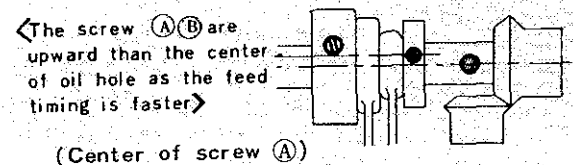
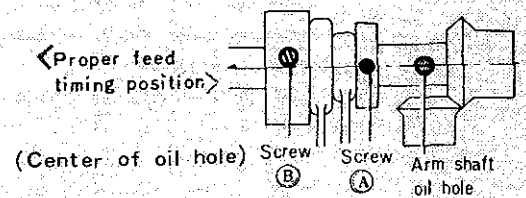
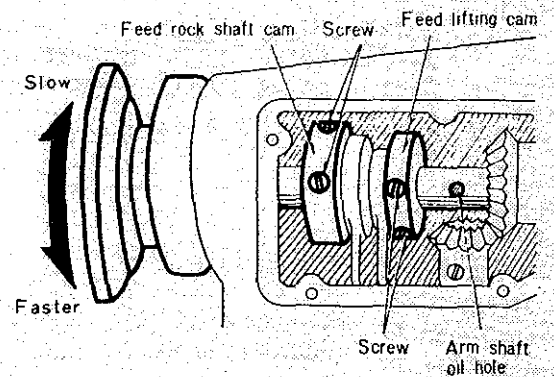

- * The relative position of the feed rock shaft and feed lifting cam will be fixed with one screw (screw A B) out of three screws.
- * The proper feed timing is based on the center of arm shaft oil hole, so set the center of screw A to the center of the oil hole.
- * Remember that it is necessary for the relative position of the screw A B should be as shown in Fig.

V. CLEANING AND LUBRICATION

1. CLEANING

1) Cleaning of feed dog

- ◆ The teeth of feed dog is often covered with dust so that causes improper operation and un-uniform stitching.
- ◆ Please clean occasionally. Clean the dust by brush removing the needle plate.

Cleaning of the feed dog should be proceeded before cleaning of the shuttle hook.

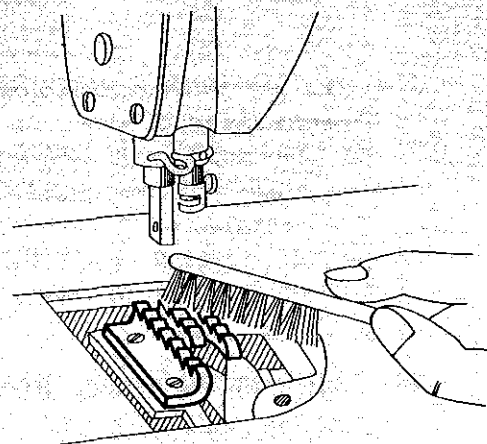

2) Cleaning of the shuttle hook

- ◆ The dust accumulating at the grooved parts of the shuttle hook are automatically cleaned of the dust. However, as far as the dust accumulating inside and outside of the shuttle hook, clean away with brush turning the shuttle hook slowly.

The shuttle hook constitutes the most vital part of the machine, therefore must maintain cleaning at all times.

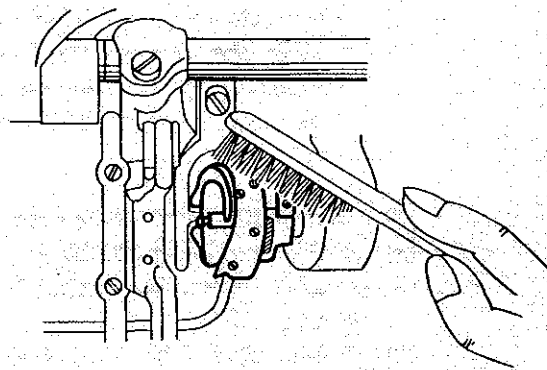

3) Replacing of the oil filter

- ◆ An excess oil lubricated automatically by means of oil pump will naturally returned to the oil tank. But oils of reservoir in the jaw will automatically back flow by oil pump and back flow pipe.
 - ◆ The filter fixed on the end of back flow pipe stop up often with the dust, waste thread and fabrics starch so that back flow capability would be out of order. Please check it up once a month removing the face plate.
 - ◆ In case of the filter is stopped up, replace it with new one in the following ways.
 - ◆ Clean the removed filter away, and keep it as for your next replacement.
- (1) Remove the face plate.
 - (2) Take out the oil back flow pipe.
 - (3) Take out the filter by tweezer from the arm.

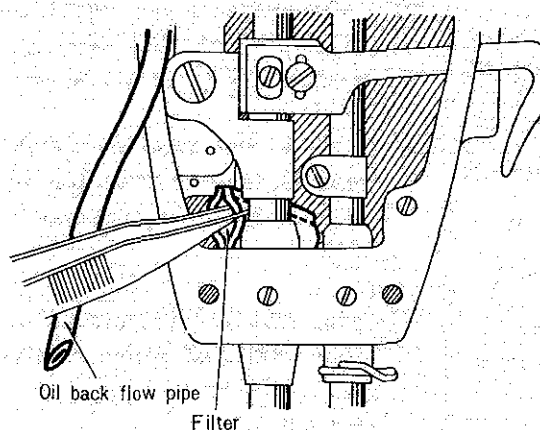

- (4) Insert the spare filter into the tip of oil back flow pipe.
- (5) Hold the filter together with the tip of oil back flow pipe by tweezers, and then insert it in the jaw as it was.
- (6) After replaced it, while holding the filter by tweezers, pull out the oil back flow pipe by abt. 5mm. for purpose of keeping a gap between tip of filter and the pipe.
- (7) Lubricate into the jaw reservoir enough properly.
- (8) Check it up operating the machine whether the oil properly back flow.
- (9) After check it up, fit the face plate as it was.
- (10) The replaced filter should be cleaned and kept it with you.

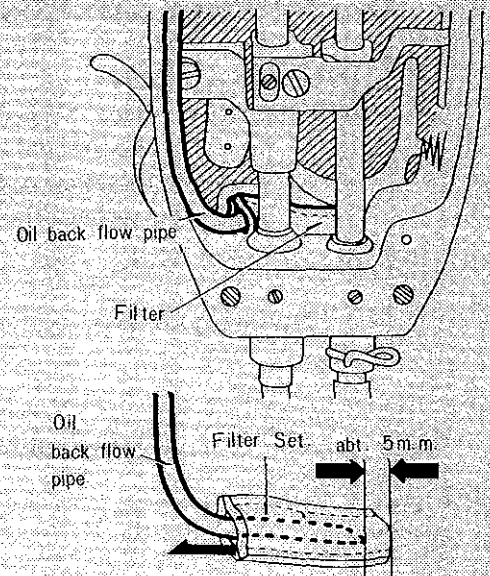

4) Cleaning of oil tank

During long-period using the machine, the oil tank would be filled with the dust, waste thread, sediment and oils become dirty, so please clean away periodically draining oils.

5) Cleaning of oil pump

Clean away the oil pump screens by brush periodically, as the screen would be dusted and make lubrication capability wrong.

2. REPLACEMENT OF OILS

The oils of oil tank would be dust and lost its aim of lubricating due to long-period using.

Occasionally check it up and replace with new one in the following ways.

- (1) Lay down the machine head toward the other side.
- (2) Put oil receptacle under the oil draining hole of the oil drop pan.
- (3) Remove the oil draining screw fixed at right side of oil tank so that oils will drain out.
- (4) After oil is drained out, tighten the screw as it was.
- (5) After cleaned away the oil tank and fill the new oils.

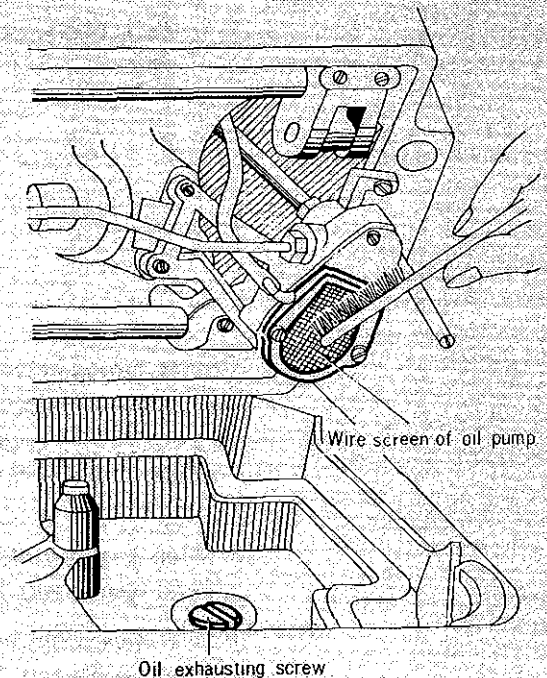

Please use always white spindle oils for the machine.

VI. TROUBLE AND REPAIRING

1. Stitch skipping

Needle

- ◆ Bent
- ◆ Insufficient quality
- ◆ Insertion not enough
- * wrong attached

Change the needle with new one.
Replace with good quality one.

Insert to the bottom of the needle clamp.

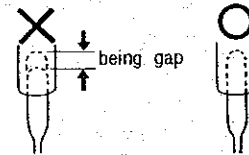

- * Needle distorted

Attach the needle as its hole faces sideways. (But, using the nylon or dacron thread, distance the needle hole somewhat, after checking of looper finish)

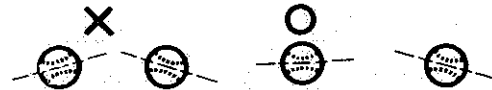

- * Attached with its opposite side

Correct the attaching side.
Attached the needle keeping its groove side toward the left, and concave side toward the right.

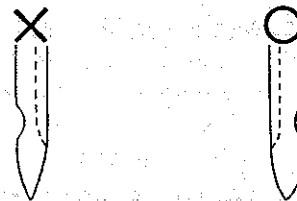

Proper timing between the needle and tip of hook:

- ◆ Needle point position too high or too low.
- ◆ Gap between the tip of hook and needle too large
- ◆ Relative position of the hook and needle too faster or too slow.
- ◆ Damaged tip of hook

At its lowest position, conform the center of needle hole with the inner surface of the shuttle hook (See page 18)

Correct the gap by 0.05mm (See page 19)

Correct the hook position, when the needle is raised 2.4mm from its lowest position, set the tip of hook at the center of needle. (See page 18)

Either change the hook or smooth by oil stone (See page 18)

Presser foot

- ◆ Pressure of presser foot too weak

Turn the pressure regulating thumb screw to the right to increase enough to not wrinkle (See page 17)

2. Irregular stitches

Upper thread tension regulator

- ◆ Pressure for tension discs Turn its nut to the right to increase the pressure (See page 14)
- ◆ Thread take up spring too weak Turn the tension stud to the right to increase (See page 15)
- ◆ Operating range of thread take up spring too narrow Turn the tension stud to the right to increase operating range (See page 15)
- ◆ Dust deposit between tension discs Remove the tension regulator nut and discs, and burnish the inside of discs thread guide on the stud.

Bobbin and bobbin case

- ◆ Lower thread tension too weak Turn the bobbin case tension screw to the right to increase (See page 16)
- ◆ Dust deposit into bobbin case Remove the bobbin case, and clean by brush
- ◆ Bobbin case tension spring bent or broken Either change the bobbin case or repair the bending.
- ◆ Placing of bobbin into bobbin case not correct When pulling out the thread after placed the bobbin into bobbin case, change it so as to turn clockwise (See page 12)
- ◆ Poor winding of thread on bobbin or too winding Re-wind the thread correctly (Bobbin is wound up to 4/5 of its full capacity with thread paralleled with the bobbin spindle) (See page 11)

3. Thread cuts

Thread

- ◆ Poor thread Change the thread with better quality one. (no irregular thread used)
- ◆ Right twisted thread used for upper thread Use the left twisted thread for upper thread.
- ◆ Thread too big for the needle size Either change with the proper size thread or with the proper needle.

Needle

- ◆ Crooked needle Replace with new needle.
- ◆ Poor needle groove and hole Replace with good needle.
- ◆ Needle attaching not correct Attach the needle as its grooved side to the left and concave side to the right.

Needle and hook

- ◆ Relative position of the hook and needle not matching Regulate the hook set position (See page 18)

Upper thread tension regulator:

- ◆ Upper thread tension too strong Turn the tension regulator nut to the left to weaken (See page 14)
- ◆ Operating range of thread take up spring too large Turn the tension regulator to the left to decrease (See page 15)
- ◆ Thread take up spring too strong Turn the tension stud to the left to weaken (See page 15)

Hook, Bobbin case and Needle plate

- ◆ The hook and bobbin case damaged (while operating, if you pull out the sewing materials, and the insufficient position between the needle and hook, and bent needle used, the hook will be damaged by the needle) Either change with new one or grind by oil stone. (Caution whether the tip of hook and the blade edge for threading are damaged or not)

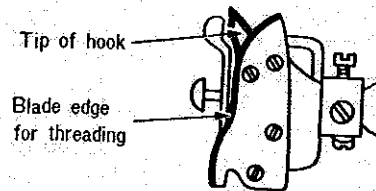

- ◆ Damaged needle hole in the needle plate (Take care that if the bent needle is used and pulled out the materials forcibly, the hook would be damaged) Either grind the needle hole or change with new needle plate.

4. Puckering Thread and Needle

- ◆ Thread and needle too thick for material (In case of sewing up thin material, thicker thread and needle causes puckering) Change with fine thread and needle.

Presser foot

- ◆ The pressure by presser foot too strong Turn the presser regulating thumb screw to the left to weaken (See page 17)

Upper and lower thread

- ◆ Upper thread tension Turn the tension nut to the left to weaken (See page 14)
(Thread take-up spring too strong)
- ◆ Lower thread tension Turn the tension screw of bobbin case to the left to weaken (See page 16)

Feed dog

- ◆ The feed dog too high Loosen the screw of the feed lifting rock shaft crank, and adjust the height of feed dog (See page 17)
- ◆ Stitch length too long Shorten the stitch length for thin materials for materials

5. Irregular stitching

Needle

- ◆ Bent needle or damaged needle point Either grind by an oil stone or replace with new one.

Presser foot and feed dog

- ◆ Pressure of presser foot too weak Turn the presser regulating thumb screw to the right to strengthen (See page 17)
- ◆ Improper height of the feed dog Loosen the screw of feed lifting rock shaft crank, and adjust the height of the feed dog (See page 17)

6. Needle breaks

Quality of Needle

- ◆ Bent needle Replace with new one.
- ◆ Weak-kneed of needle Change with good quality one.

How to attach the needle

- ◆ Needle attached not enough Insert to the bottom of the needle clamp.
- ◆ Needle knocks against hook Either the gap between the tip of hook and needle or improper relative position of the needle and the hook:
(See page 18, 19)
The gap between the tip of hook and needle is by 0.05mm.
Adjust the relative position as the center of needle hole to come to inner side of the shuttle hook at the lowest position of the needle.

Feed dog timing

- ◆ The relative position between the feed dog and needle not correct Loosen the set screw of feed cam, and adjust the feed dog timing (See page 19)

M E M O

A series of horizontal dashed lines for writing a memo.

VII. PARTS BOOK

(High speed, Single needle, Lock Stitch Machine)

Remarks: When ordering parts, be sure to include model number, parts number and its figure number.

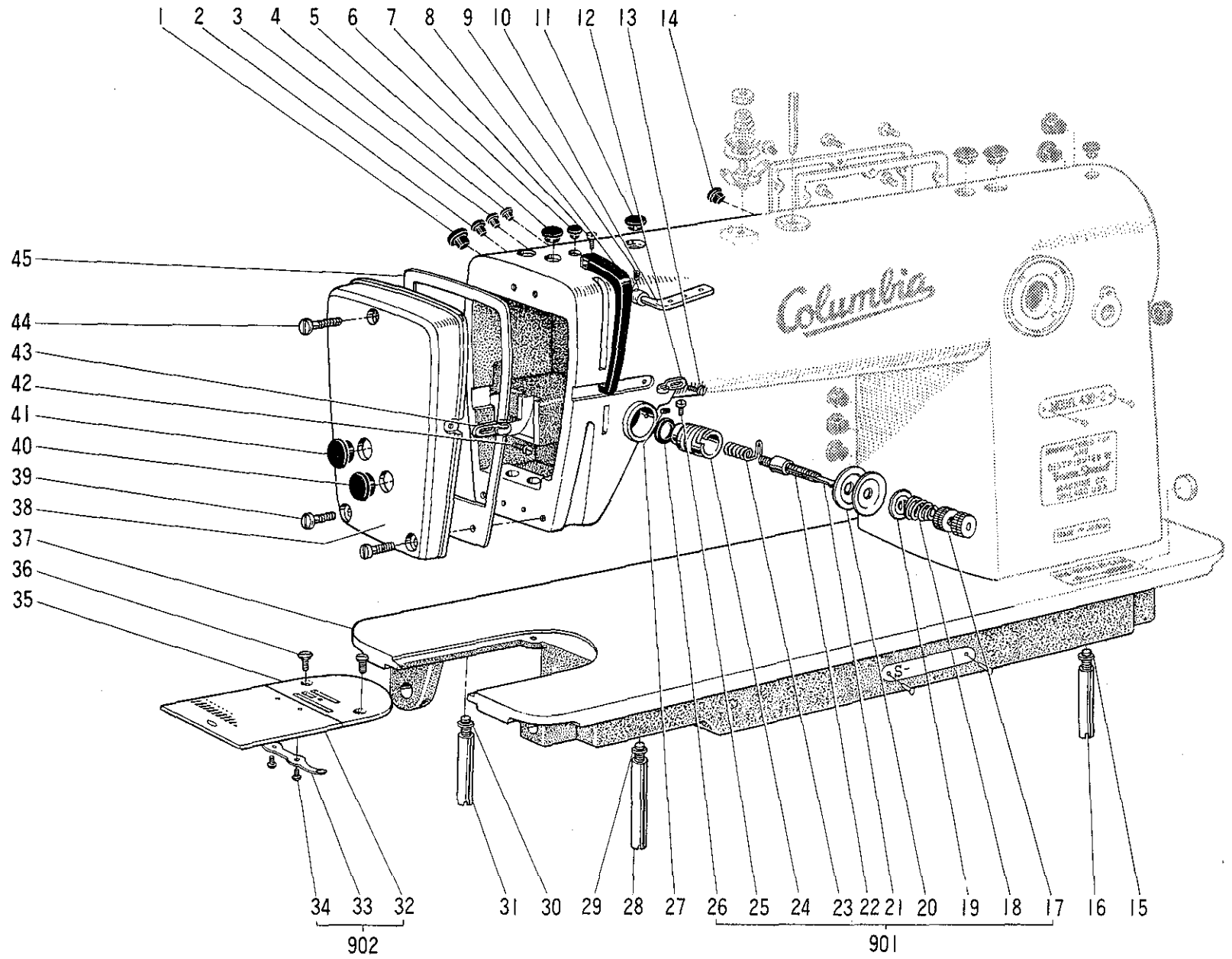

Arm bed & its accessories

Fig. No.	Parts No.	Parts Name	Amt. req.	Fig. No.	Parts No.	Parts Name	Amt. req.
1	W501374	Rubber plug (19 ϕ)	1	25	W500741	Set screw (for Fig. 22) 9/64(40) x 4	1
2	W501320	Rubber plug (8.8 ϕ)	1	26	W502087	Rubber ring (for Fig. 24)	1
3	W501320	Rubber plug (8.8 ϕ)	1	27	B509088	Set screw (for Fig. 901) 15/64(28) x 7	1
4	W501320	Rubber plug (8.8 ϕ)	1	28	W462654	Washer (for Fig. 29)	1
5	W501320	Rubber plug (8.8 ϕ)	1	29	W461768	Long leg (for Fig. 37)	1
6	W502078	Oiling rubber plug (red 5.7 ϕ)	1	30	W462654	Washer (for Fig. 31)	1
7	W500092	Screw (for Fig. 8) 11/64 (40) x 5.5	1	31	W452343	Short leg (for Fig. 37)	1
8	W450063	Thread take-up cover	1	902	W461757	Slide plate complete	1
9	B503846	Set screw (for Fig. 10) 11/64 (40) x 5.5	1	32	B419208	Slide plate	1
10	B409034	Three-hole thread guide	1	33	B419207	Spring (for Fig. 32)	1
11	W502944	Oiling rubber plug (red 8.8 ϕ)	1	34	B509070	Screw (for Fig. 33) 3/32(56) x 2.2	2
12	W452151	Arm thread guide	1	35	W319330	Needle plate	1
13	W501901	Screw (for Fig. 12) 9/64 (40) x 6	1	36	W500197	Screw (for Fig. 35) 11/64(40) x 5.5	2
14	W501320	Rubber plug (8.8 ϕ)	1	37	W321591	Arm bed complete	1
15	W462654	Washer (for Fig. 16)	1	38	W321296	Face plate	1
16	W452343	Short leg (For Fig. 37)	1	39	W500164	Screw (for Fig. 38) 11/64(40) x 10	2
901	W450067	Thread tension regulator complete	1	40	W502069	Rubber plug (for Fig. 38) 11.8 ϕ	1
17	W501027	Thread tension regulating thumb nut	2	41	W502069	Rubber plug (for Fig. 38) 11.8 ϕ	1
18	W450071	Thread tension spring	1	42	W501901	Screw (for Fig. 43) 9/64(40) x 6	1
19	B419179	Thread tension releasing disc	1	43	W452151	Face plate thread guide	1
20	W444059	Thread tension disc	2	44	W500164	Screw (for Fig. 38) 11/64(40) x 10	1
21	B509216	Thread tension releasing pin	1	45	W450046	Gasket (for Fig. 38)	1
22	B419178	Thread tension stud	1				
23	W450070	Thread take-up spring	1				
24	W453140	Thread tension regulator bushing	1				

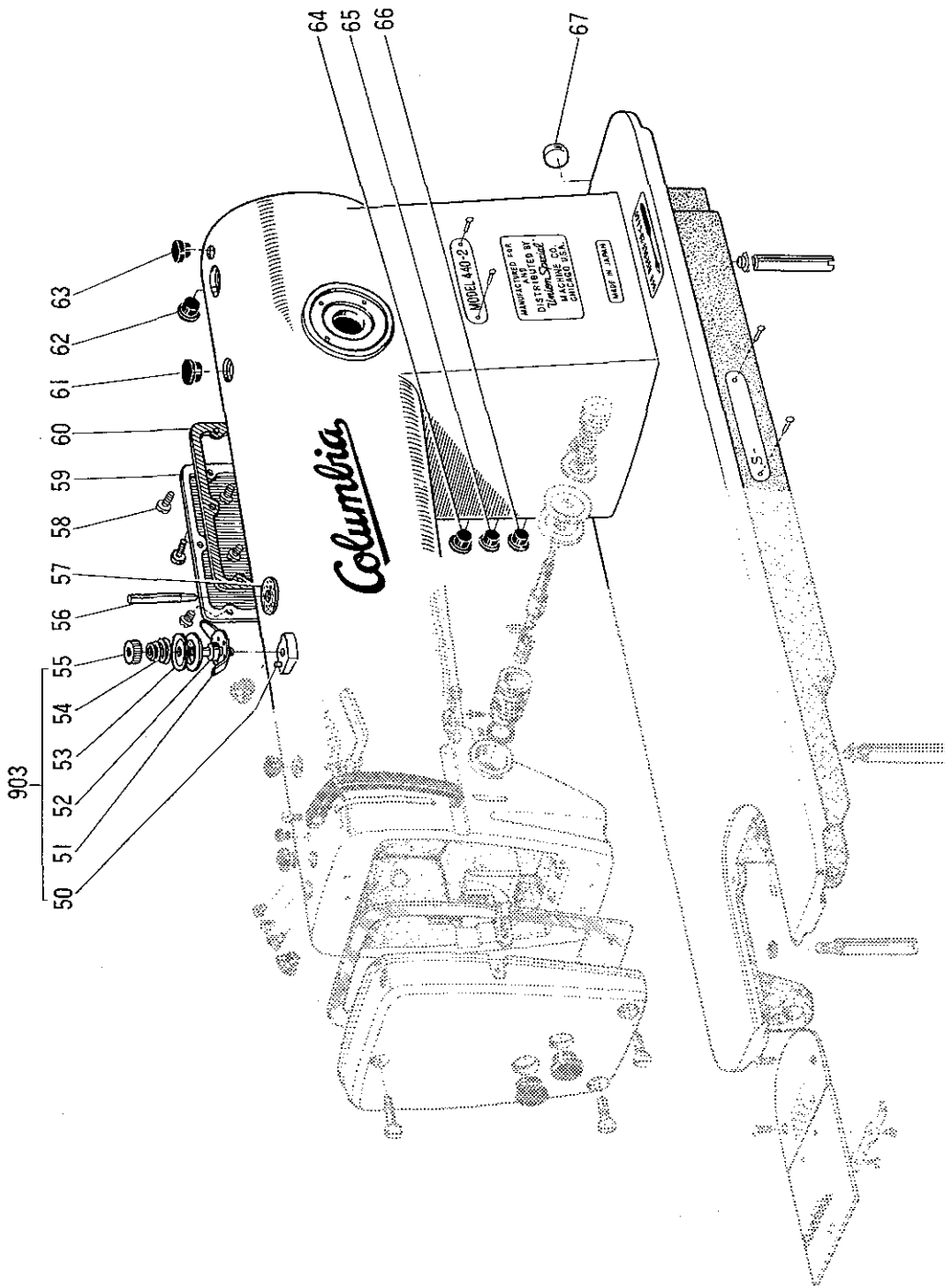
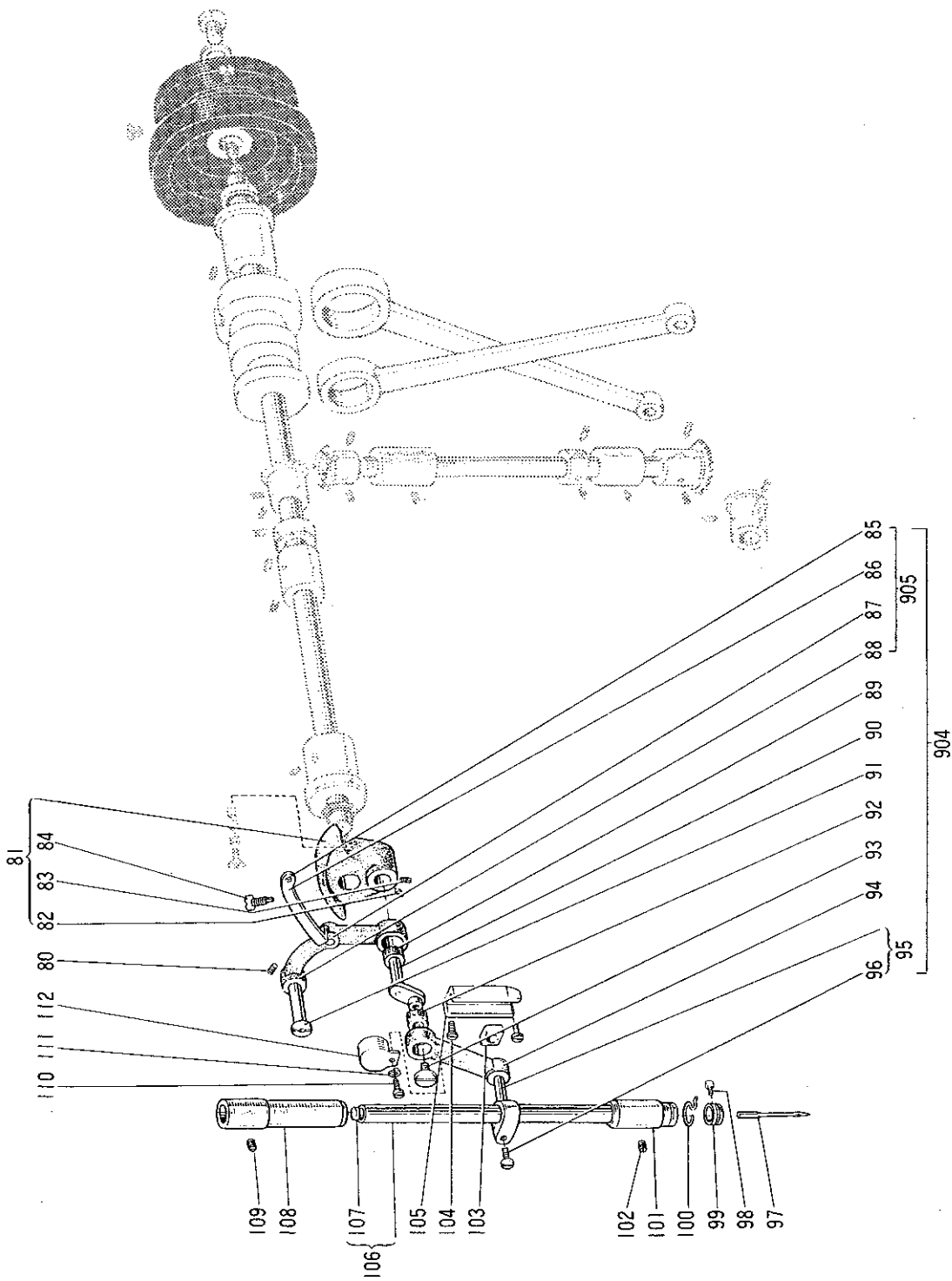

Fig. No.	Parts No.	Parts Name	Amt. req.
903	W450619	Pre-tension complete	1
50	W500810	Stopper pin (for Fig. 51)	1
51	W502172	Thread guide (for pre-tension)	1
52	W502171	Tension stud (for pre-tension)	1
53	W501636	Tension discs (for pre-tension)	2
54	W502193	Tension spring (for pre-tension)	1
55	W501637	Tension nut (for pre-tension)	1
56	W461744	Spool pin	1
57	B422836	Felt sheet (for Fig. 56)	1
58	W500294	Screw (for Fig. 59) 11/64(40) x 8	5
59	W450047	Arm side cover	1
60	W450048	Gasket (for Fig. 59)	1
61	W501374	Rubber plug (19 ϕ)	1
62	W501320	Rubber plug (8.8 ϕ)	1
63	W502078	Oiling rubber plug (red 5.7 ϕ)	1

Fig. No.	Parts No.	Parts Name	Amt. req.
64	W501320	Rubber plug (8.8 ϕ)	1
65	W501320	Rubber plug (8.8 ϕ)	1
66	W501320	Rubber plug (8.8 ϕ)	1
67	W500162	Iron plug	1



Needle bar & thread take-up mechanism

Fig. No.	Parts No.	Parts Name	Amt. req.	Fig. No.	Parts No.	Parts Name	Amt. req.
80	W500006	Set screw (for Fig.91) 15/64 (28) x 15	1	98	W502074	Needle clamp screw 1/8 (44) x 4.5	1
81	W450075	Crank with set screw	1	99	W502075	Needle bar thread guide	1
82	B 504016	Set screw (for Fig.81) 1/4 (40) x 6	1	100	W502073	Needle bar bushing thread guide	1
83	B504016	Set screw (for Fig.81) 1/4 (40) x 6	1	101	W450055	Needle bar bushing (under)	1
84	B 503851	Set screw (for Fig.81) 9/32 (28) x 14	1	102	W500489	Set screw (for Fig.101) 11/64 (40) x 2.7	1
904	W324586	Thread take-up lever & needle bar connecting stud complete	1	103	W443934	Square block (for Fig. 95)	1
905	W450057	Thread take-up lever complete	1	104	W500294	Screw (for Fig. 105) 11/64 (40) x 8	2
85	W502077	Thread take-up lever eyelet	1	105	W444056	Needle bar connecting link guide	1
86	W450058	Thread take-up lever	1	106	W450053	Needle bar	1
87	B 509045	Set pin (for Fig. 86)	1	107	W502071	Plastic plug (for Fig. 106)	1
88	W450061	Thread take-up connecting rod	1	108	W450052	Needle bar bushing (upper)	1
89	W450060	Needle roller bearing (for Fig.90)	1	109	B508971	Set screw (for Fig. 108) 15/64 (28) x 4.5	1
90	W450059	Thread take-up crank	1	110	B508857	Screw (for Fig.112) 1/8 (44) x 6	1
91	W450062	Set pin (for Fig. 88)	1	111	W461769	Washer (for Fig. 110)	1
92	W450060	Needle roller bearing (for Fig. 90)	1	112	W444871	Cap (for Fig. 93)	1
93	W502076	Left thread screw (for Fig. 94) 9/64 (40) x 8.8	1				
94	W450056	Needle bar connecting link	1				
95	W450054	Needle bar connecting stud	1				
96	W501901	Screw (for Fig.95) 9/64 (40) x 6	1				
97	—	Needle	1				

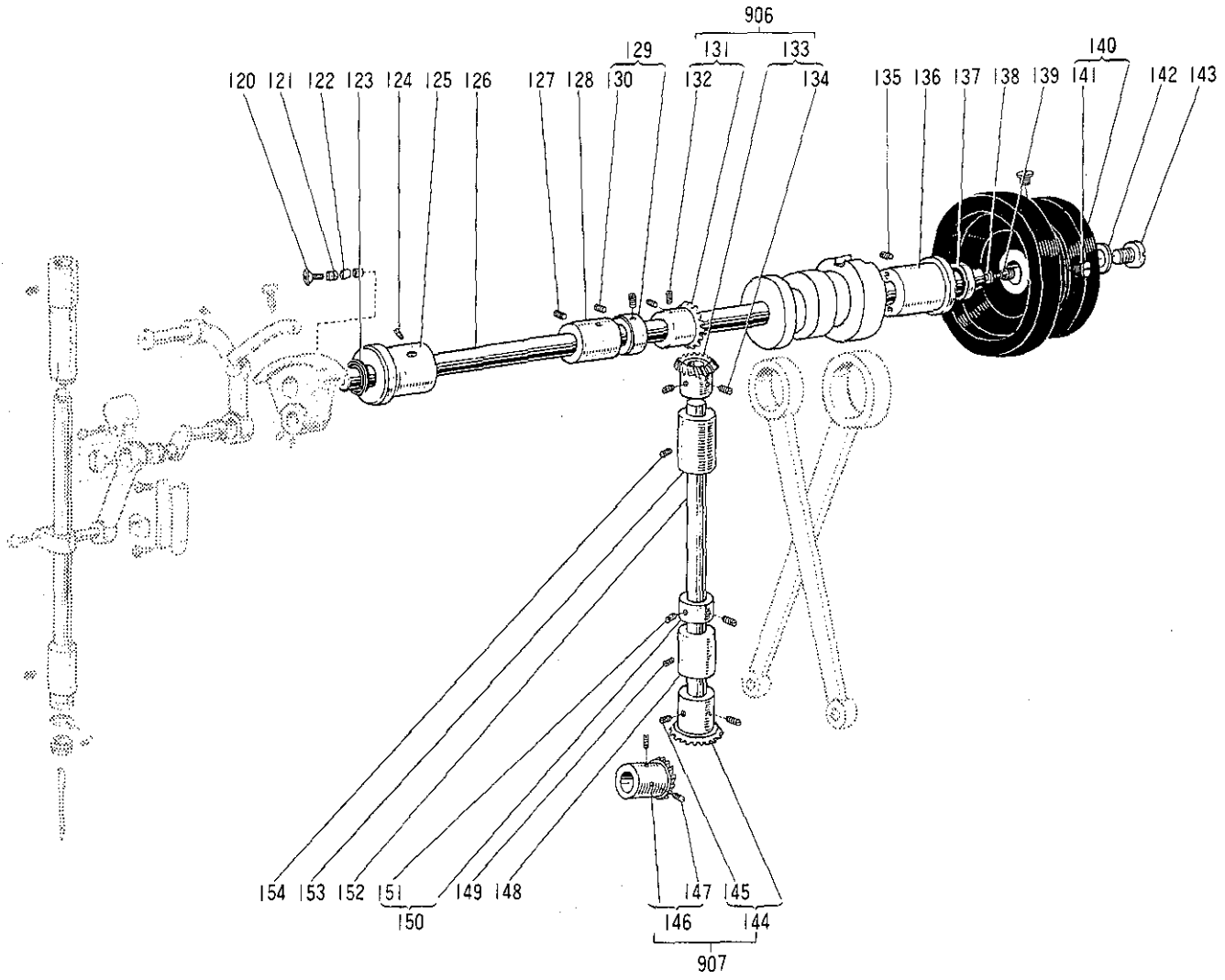

Arm shaft & its accessories

Fig. No.	Parts No.	Parts Name	Amt. req.	Fig. No.	Parts No.	Parts Name	Amt. req.
120	W502474	Screw (for arm shaft front) 5/16(20) x 4.3	1	139	W502088	Screw (for arm shaft back) 11/32(28) x 15.5	1
121	W500003	Felt (for arm shaft front)	3	140	W453501	Balance wheel	1
122	W501905	Alumi.plug (for arm shaft front)	1	141	W500509	Set screw (for Fig. 140) 15/64(28) x 12	2
123	W461777	Oil seal (for arm shaft front)	1	142	W500233	Rubber gasket (for Fig. 126)	1
124	W500006	Set screw (for Fig. 125) 15/64(28) x 15	1	143	W461726	Screw (for Fig. 142) 11/32(28) x 10	1
125	W450076	Arm shaft bushing (front)	1	907	W462637	Hook shaft bevel gear complete	1
126	W322723	Arm shaft	1	144	W444109	Bevel gear (vertical shaft under)	1
127	W500006	Set screw (for Fig. 128) 15/64(28) x 15	1	145	B504016	Set screw (for Fig. 144) 1/4(40) x 6	2
128	W450077	Arm shaft bushing (middle)	1	146	W444111	Bevel gear (hock shaft)	1
129	W450079	Arm shaft collar	1	147	B504016	Set screw (for Fig. 146) 1/4(40) x 6	2
130	B509088	Set screw (for Fig. 129) 15/64(28) x 7	2	148	W450082	Vertical shaft bushing (under)	1
906	W462638	Arm shaft bevel gear complete	1	149	B509060	Set screw (for Fig. 148) 15/64(28) x 10	1
131	W444106	Bevel gear (arm shaft)	1	150	B422844	Vertical shaft collar	1
132	B504016	Set screw (for Fig. 131) 1/4(40) x 6	2	151	B508971	Set screw (for Fig. 150) 15/64(28) x 4.5	2
133	W444107	Bevel gear (vertical shaft upper)	1	152	W450080	Vertical shaft	1
134	B504016	Set screw (for Fig. 133) 1/4(40) x 6	2	153	W450081	Vertical shaft bushing (upper)	1
135	W500006	Set screw (for Fig. 136) 15/64(28) x 15	1	154	B509060	Set screw (for Fig. 153) 15/64(28) x 10	1
136	W450078	Arm shaft bushing (back)	1				
137	W461784	Oil seal (for arm shaft back)	1				
138	W461758	O-ring (for arm shaft back) P4	1				

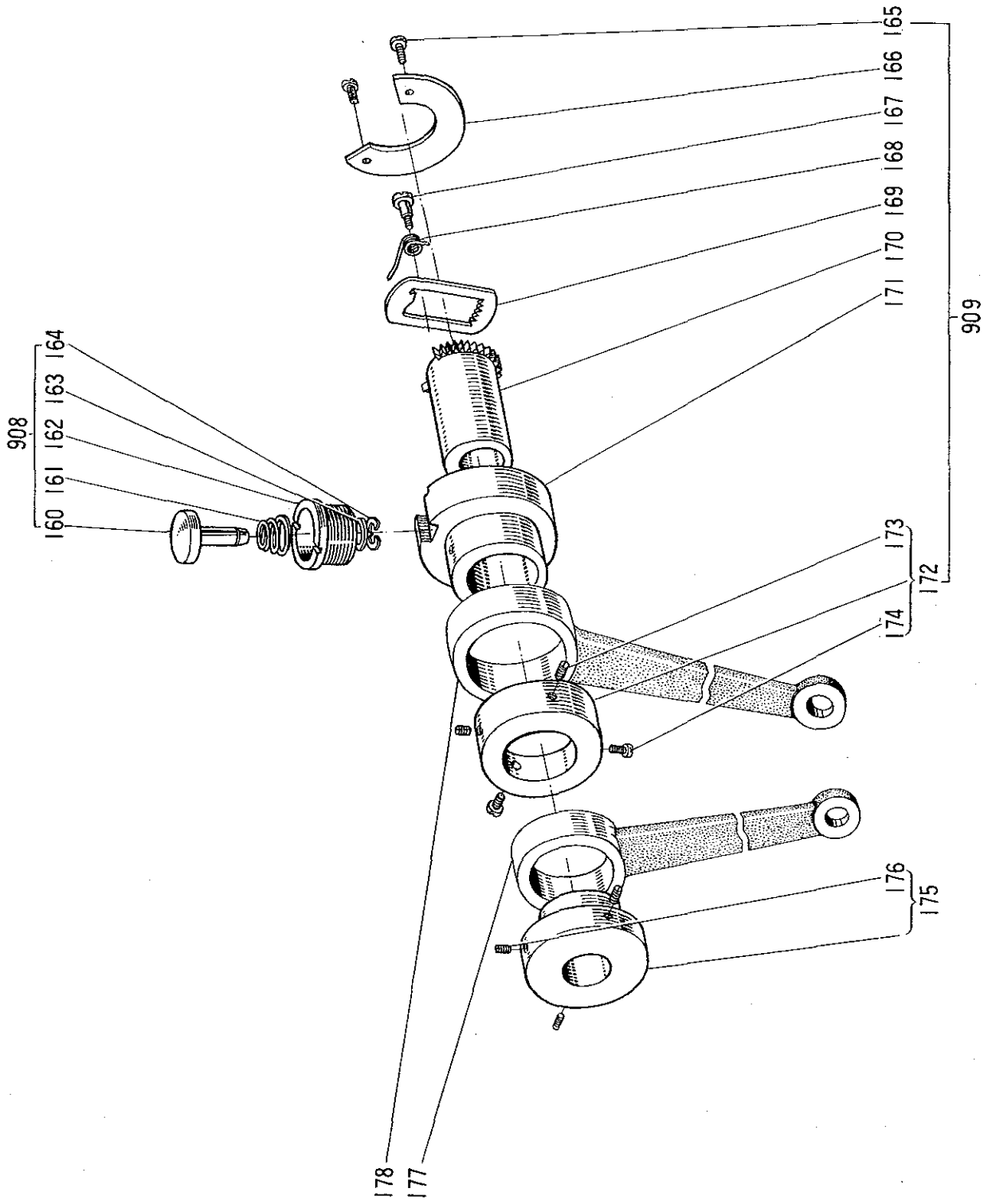

Stitch length regulator mechanism

Fig. No.	Parts No.	Parts Name	Amt. req.	Fig. No.	Parts No.	Parts Name	Amt. req.
908	W462623	Feed regulating push button complete	1	173	B 509060	Set screw (for Fig. 172) 15/64(28) x 10	2
160	W460512	Push button (for feed regulator)	1	174	W500509	Set screw (for Fig. 172) 15/64(28) x 12	2
161	W462657	Spring (for Fig. 160)	1	175	W452341	Feed lifting cam	1
162	W462656	Bushing (for Fig. 160)	1	176	W500706	Set screw (for Fig. 175) 15/64(28) x 9	3
163	W501110	Rubber gasket (for Fig. 162)	1	177	W450961	Feed lifting rock shaft crank rod	1
164	W461793	Snap-ring (for Fig. 160)	1	178	W320076	Feed rock shaft crank rod	1
909	W462628	Feed regulator complete	1				
165	W500791	Screw (for Fig. 166) 9/64(40) x 4.5	2				
166	W446371	Cover plate (for Fig. 169)	1				
167	W501162	Screw (for Fig. 168)	1				
168	W501163	Spring (for Fig. 169)	1				
169	W446370	Clutch plate (for Fig. 170)	1				
170	W450959	Eccentric link	1				
171	W450958	Feed rock shaft cam	1				
172	W450960	Collar (for Fig. 178)	1				

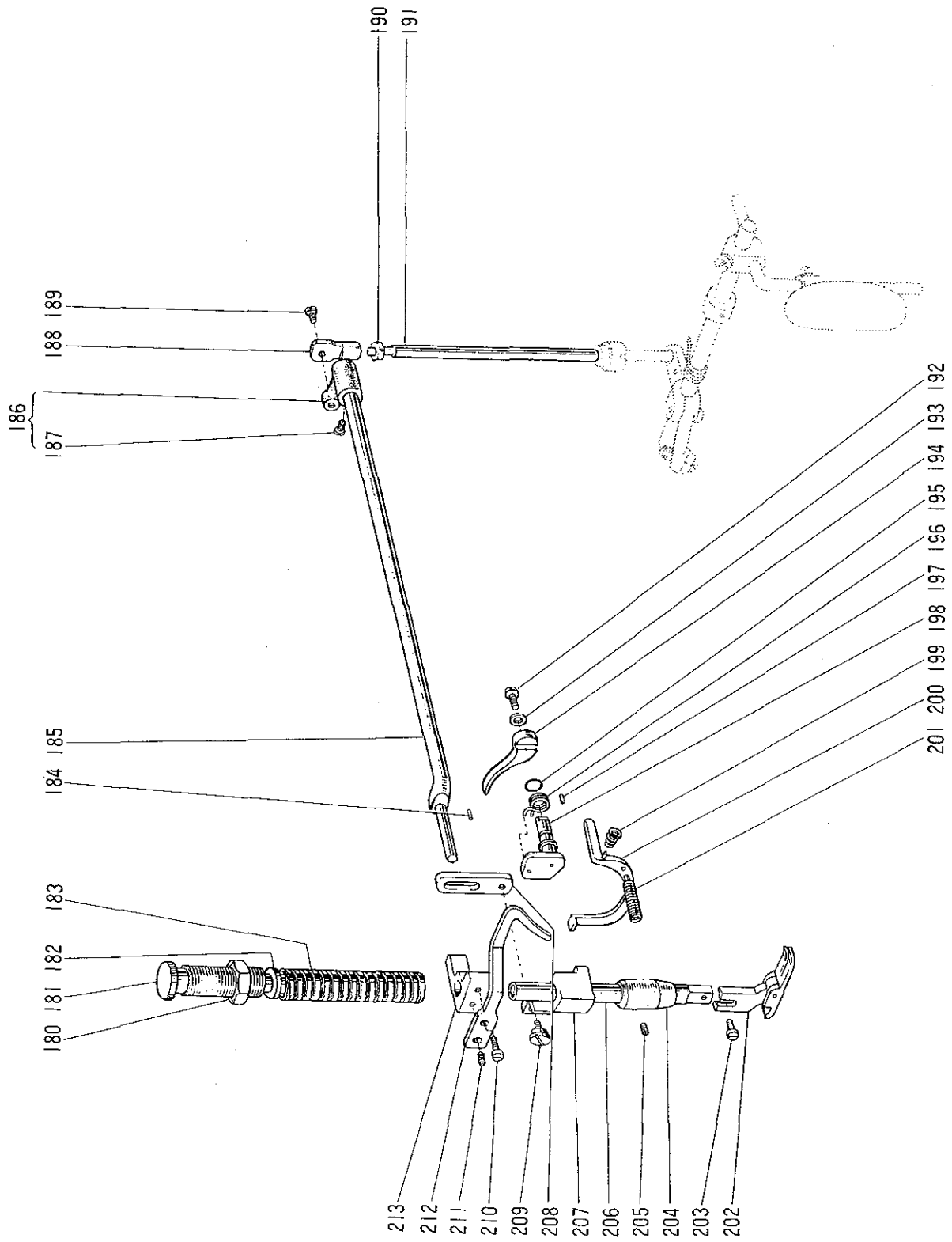

Presser foot mechanism

Fig. No.	Parts No.	Parts Name	Amt. req.	Fig. No.	Parts No.	Parts Name	Amt. req.
180	W501118	Nut (for Fig. 181) 1/2(28)	1	200	W502086	Tension releasing lever	1
181	W502440	Pressure regulating thumb screw	1	201	W502123	Set screw (for Fig. 200)	1
182	W502439	Presser bar guide	1	202	W450580	Presser foot	1
183	W502444	Presser spring	1	203	B508848	Screw (for Fig. 202) 9/64(40) x 8	1
184	W501874	Stopper pin (for Fig. 185)	1	204	W502081	Presser bar bushing	1
185	W450108	Knee lifter lever	1	205	W500489	Set screw (for Fig. 204) 11/64(40) x 2.7	1
186	W502103	Knee lifter crank	1	206	W502079	Presser bar	1
187	W502945	Set screw (for Fig. 186) 15/64(28) x 8.5	1	207	W450066	Presser bar lifting bracket	1
188	W450109	Knee lifter lever joint	1	208	W502084	Knee lifter lever link	1
189	W502104	Screw (for Fig. 188)	1	209	B509180	Screw (for Fig. 208)	1
190	B509177	Nut (for Fig. 191) 3/16(32)	1	210	W500092	Screw (for Fig. 212) 11/64(40) x 5.5	1
191	W450110	Knee lifter lever connecting rod	1	211	B509088	Set screw (for Fig. 213) 15/64(28) x 7	1
192	B508848	Screw (for Fig. 194) 9/64(40) x 8	1	212	W502083	Thread guide	1
193	W462617	Washer (for Fig. 192)	1	213	W502082	Presser bar holder	1
194	W447053	Presser bar lifter	1				
195	W461758	O-ring (for Fig. 198) P4	1				
196	W502141	Spring (for Fig. 198)	1				
197	W502150	Stopper pin (for Fig. 196)	1				
198	W450151	Presser bar lifter cam	1				
199	B409092	Spring (for Fig. 200)	1				

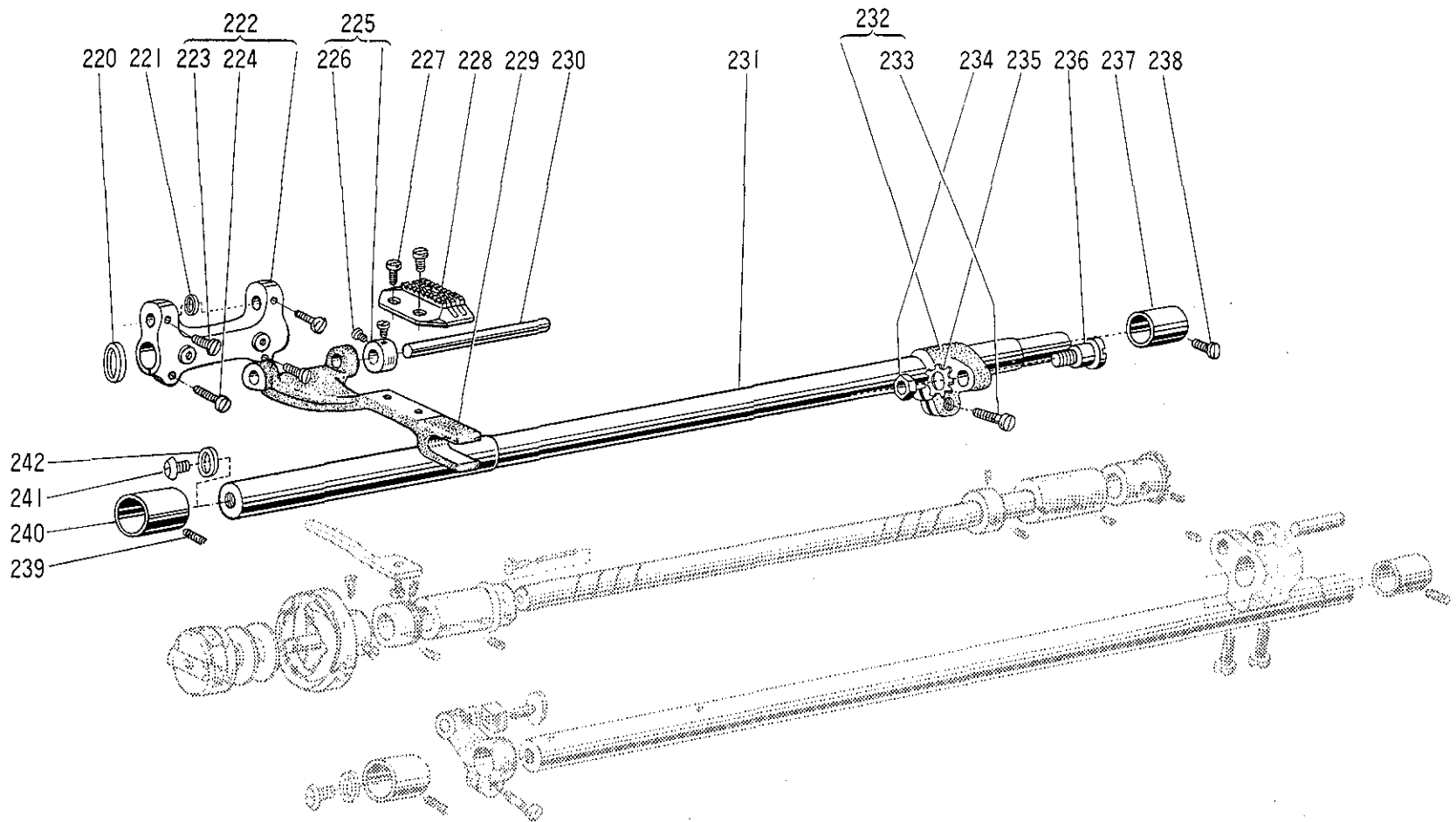

Feed rock shaft mechanism

Fig. No.	Parts No.	Parts Name	Amt. req.	Fig. No.	Parts No.	Parts Name	Amt. req.
220	W502467	Slide washer (for Fig. 222)	1	235	W461797	Lock washer (for Fig. 236)	1
221	W502480	Slide washer (for Fig. 229)	1	236	W454870	Screw (for feed rock crank rod)	1
222	W456518	Feed rock shaft crank (left)	1	237	W446173	Feed rock shaft bushing (right)	1
223	W500294	Set screw (for Fig. 230) 11/64(40) x 8	2	238	W500509	Set screw (for Fig. 237) 15/64(28) x 12	1
224	W501889	Screw (for Fig. 222) 11/64(40) x 12	2	239	B509088	Set screw (for Fig. 240) 15/64(28) x 7	1
225	W501442	Collar (for Fig. 229)	1	240	W454875	Feed rock shaft bushing (left)	1
226	W500741	Set screw (for Fig. 225) 9/64(40) x 4	2	241	W501111	Screw (for Fig. 242) 1/4(40) x 7	1
227	B508857	Screw (for Fig. 228) 1/8(44) x 6	2	242	W501110	Rubber gasket (for Fig. 231)	1
228	W462604	Feed dog	1				
229	W447752	Feed bar	1				
230	W501447	Feed bar shaft	1				
231	W454876	Feed rock shaft	1				
232	W450962	Feed rock shaft crank (right)	1				
233	W501009	Screw (for Fig. 232) 1/4(24) x 16	1				
234	B508961	Nut (for Fig. 236) 9/32(28)	1				

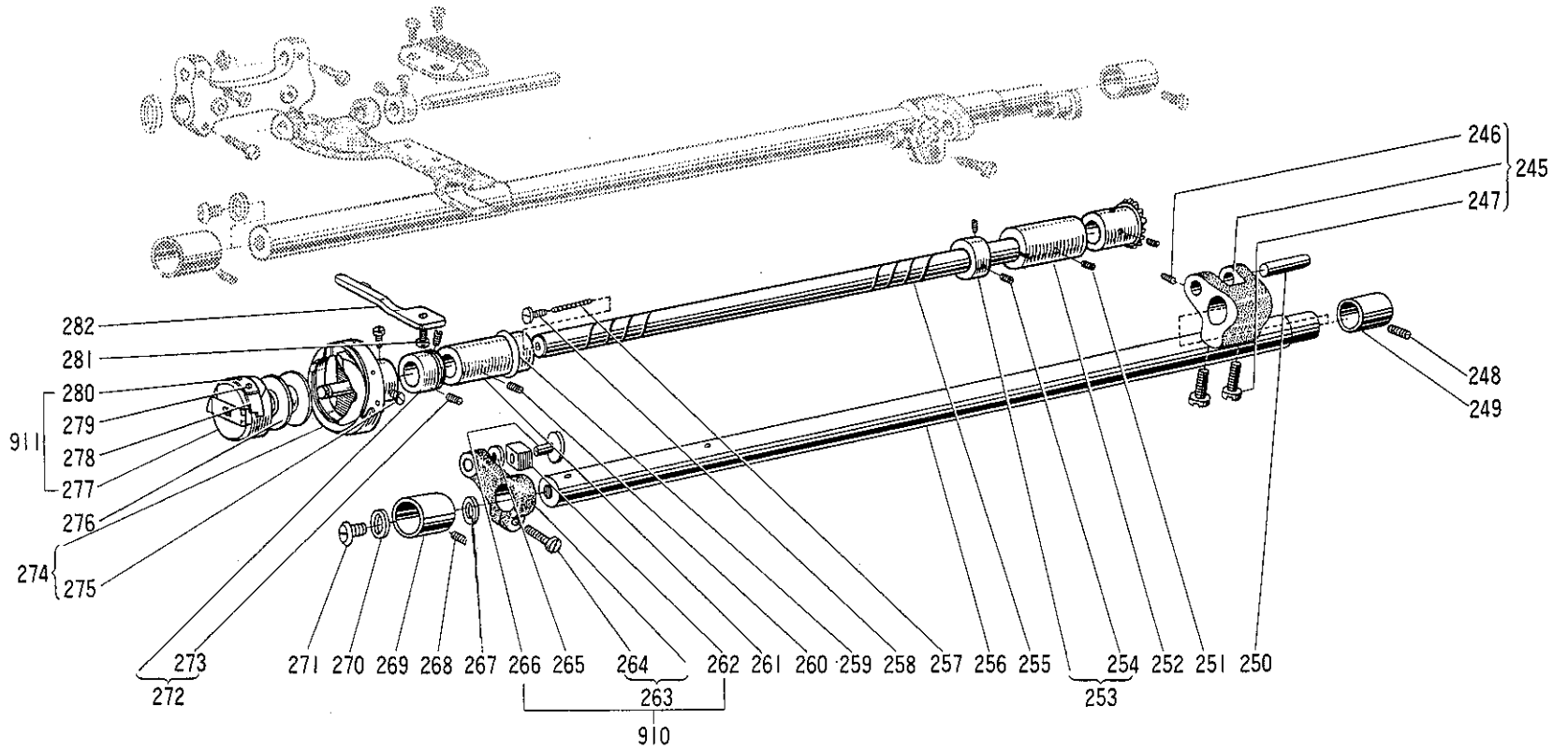

Hook shaft & Feed lifting rock shaft mechanism

Fig. No.	Parts No.	Parts Name	Amt. req.	Fig. No.	Parts No.	Parts Name	Amt. req.
245	W447173	Feed lifting rock shaft crank (right)	1	264	W500182	Screw (for Fig. 263) 11/64(40) x 15	1
246	B503846	Set screw (for Fig. 250) 11/64(40) x 5.5	1	265	W502336	Washer (for Fig. 262)	1
247	W500509	Set screw (for Fig. 245) 15/64(28) x 12	2	266	W502337	Square block set pin (for Fig. 263)	1
248	B509060	Set screw (for Fig. 249) 15/64(28) x 10	1	267	W502467	Slide washer (for Fig. 263)	1
249	W446173	Feed lifting rock shaft bushing (right)	1	268	B509060	Set screw (for Fig. 269) 15/64(28) x 10	1
250	W501107	Set pin (for feed lifting rock crank rod)	1	269	W454875	Feed lifting rock shaft bushing (left)	1
251	B509060	Set screw (for Fig. 252) 15/64(28) x 10	1	270	W501110	Rubber gasket (for Fig. 256)	1
252	W450100	Rotating hook shaft bushing (right)	1	271	W501111	Screw (for Fig. 270) 1/4(40) x 7	1
253	B422844	Collar (for Fig. 255)	1	272	W502094	Oil flow preventing collar	1
254	B508971	Set screw (for Fig. 253) 15/64(28) x 4.5	2	273	B503846	Set screw (for Fig. 272) 11/64(40) x 5.5	2
255	W450098	Rotating hook shaft	1	274	W218864	Rotating hook	1
256	W454877	Feed lifting rock shaft	1	275	W500194	Set screw (for Fig. 274) 11/64(40) x 4	2
257	W500231	Oil cotton braid (for Fig. 255)	1	276	W462632	Bobbin	1
258	W500190	Special screw (for Fig. 255) 3/16(32) x 6	1	911	W461742	Bobbin case complete	1
259	W462651	Snap spring (for Fig. 261)	1	277	B209055	Bobbin case	1
260	B509060	Set screw (for Fig. 261) 15/64(28) x 10	1	278	W462630	Thread tension spring (for Fig. 277)	1
261	W461749	Rotating hook shaft bushing (left)	1	279	B508875	Screw (for Fig. 278) 3/32(100) x 1.4	1
910	W452475	Feed lifting rock shaft crank (left) complete	1	280	B509067	Screw (for Fig. 278) 1/16(80) x 1.7	1
262	W452474	Square block (for Fig. 263)	1	281	B509061	Screw (for Fig. 282) 11/64(40) x 10	1
263	W450096	Feed lifting rock shaft crank (left)	1	282	W462633	Rotating hook positioner	1

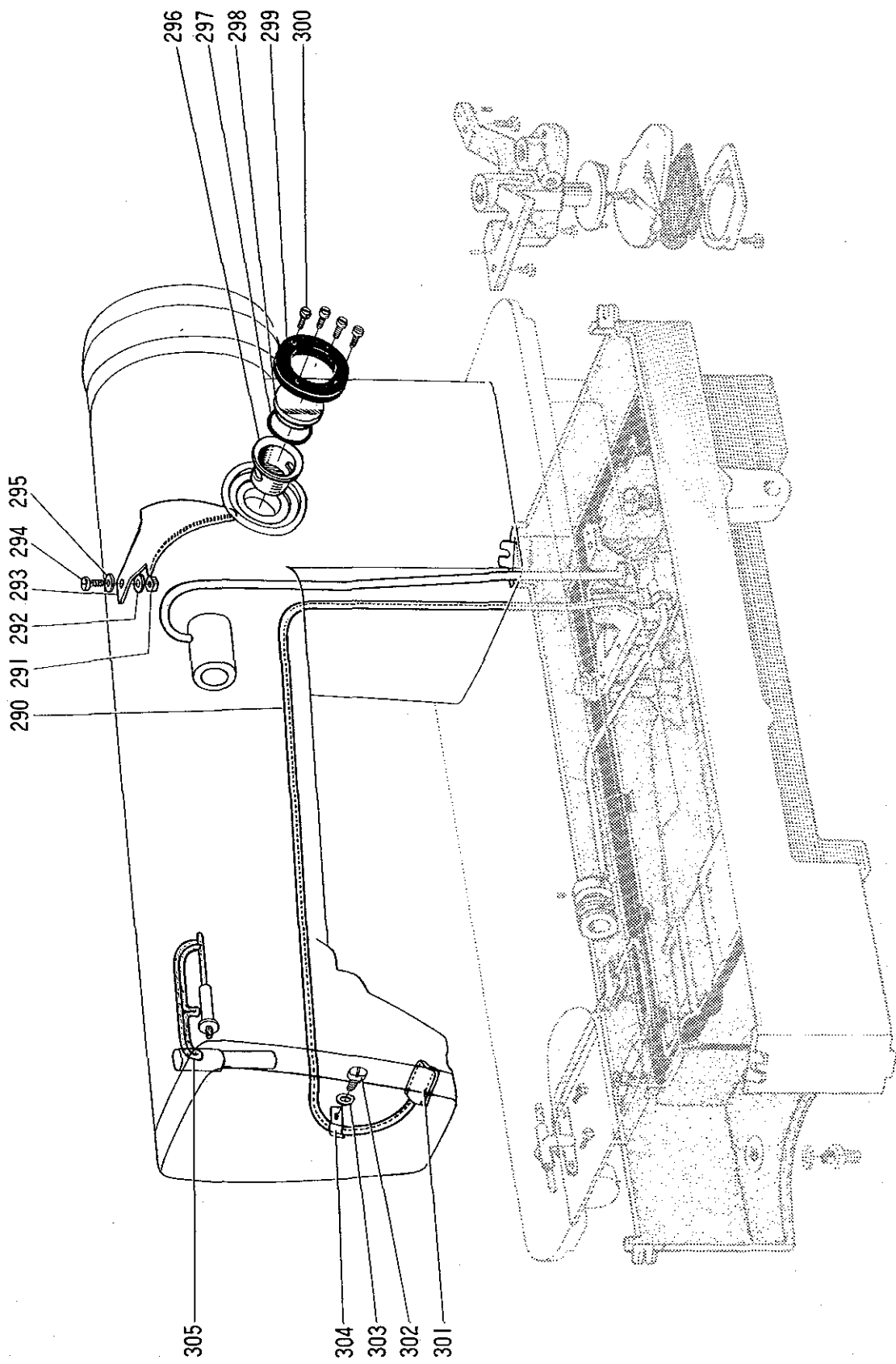

Lubrication mechanism

Fig. No.	Parts No.	Parts Name	Amt. req.	Fig. No.	Parts No.	Parts Name	Amt. req.
290	W446232	Oil return pipe	1	305	W444138	Oil cotton braid (for thread take-up & needle bar oiling)	1
291	W500307	Nut (for Fig. 294) 9/64(40)	1				
292	B508956	Washer (for Fig. 294)	1				
293	W320603	Oil guide plate	1				
294	B508848	Screw (for Fig. 293) 9/64(40) x 8	1				
295	W501692	Rubber gasket (for Fig. 294)	1				
296	W446229	Oil check window	1				
297	W462650	O-ring (for Fig. 296) P25	1				
298	W502098	Oil check sight glass	1				
299	W446230	Cover (for Fig. 298)	1				
300	B508848	Screw (for Fig. 299) 9/64(40) x 8	4				
301	W502394	Felt pouch (return oil filter)	1				
302	B509289	Screw (for Fig. 304) 11/64(40) x 7	1				
303	W500301	Washer (for Fig. 302)	1				
304	W444230	Oil return pipe holder	1				

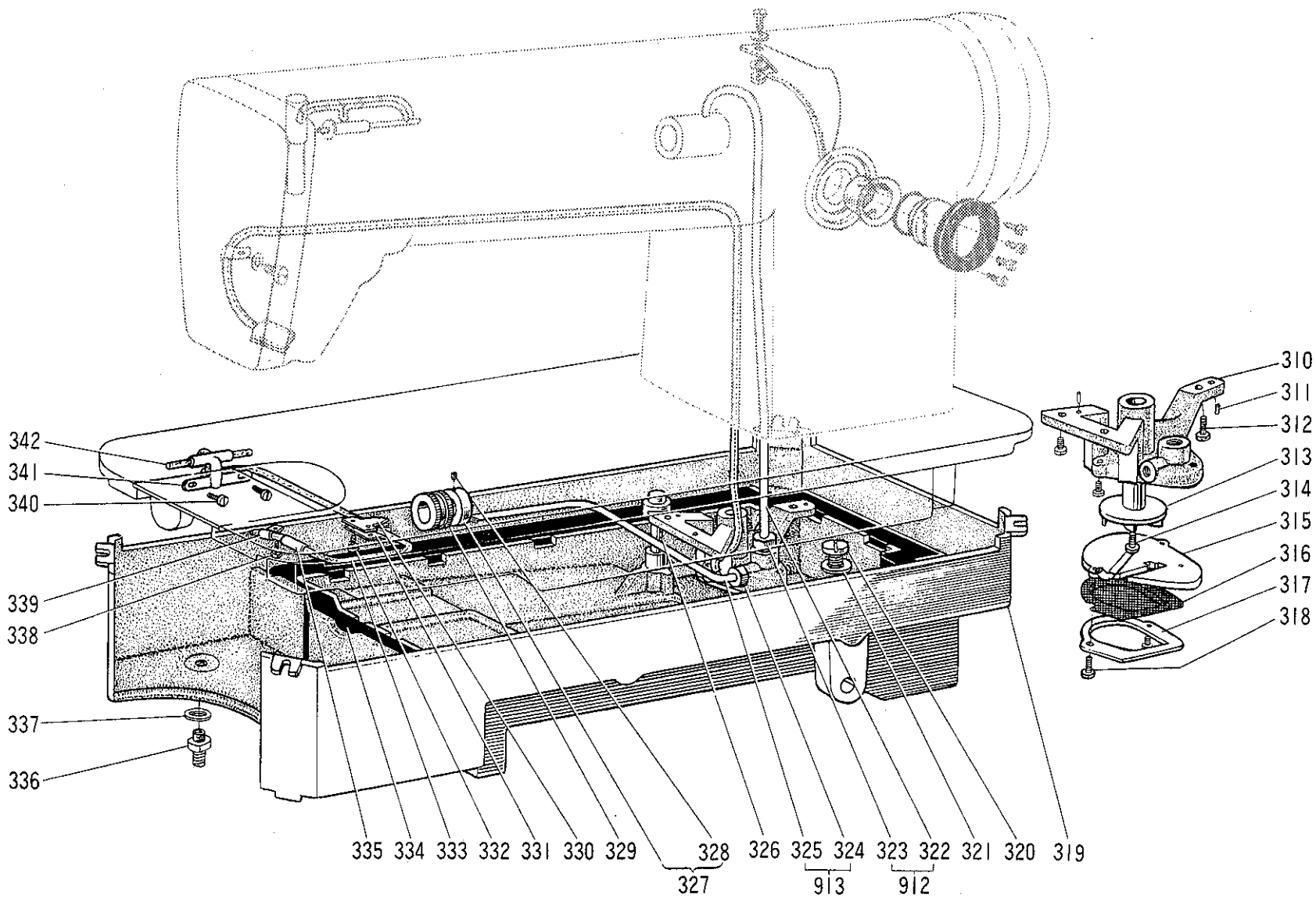

Fig. No.	Parts No.	Parts Name	Amt. req.	Fig. No.	Parts No.	Parts Name	Amt. req.
310	W321294	Oil pump (body)	1	328	W500588	Set screw (for Fig. 327) 9/64(40) x 3.7	2
311	W500212	Oil pump positioning pin	2	329	W454812	Oil adjustable ring (for hook oiling)	1
312	W500182	Screw (for Fig. 310) 11/64(40) x 15	3	330	W502095	Stopper (for Fig. 329)	1
313	W448313	Oil pump impeller	1	331	W502096	Oil cotton braid supporter	1
314	W501133	Screw (for Fig. 313) 1/8(44) x 6	1	332	W500791	Screw (for Fig. 331) 9/64(40) x 4.5	2
315	W459339	Oil suction plate	1	333	W444138	Oil cotton braid (for feed mecha, oiling)	1
316	W502363	Oil pump screen	1	334	W321295	U-shape rubber gasket (for Fig. 319)	1
317	W502362	Oil pump screen cover	1	335	W501450	Oil cotton braid holder pipe	1
318	W501086	Screw (for Fig. 317) 1/8(44) x 13	3	336	W446050	Bushing (for over flow oil pipe)	1
319	W110322	Oil reservoir	1	337	W500812	Rubber gasket (for Fig. 336)	1
320	W501327	Oil drain screw 5/16(28) x 7.2	1	338	B508857	Screw (for Fig. 339) 1/8(44) x 6	1
321	W462613	Rubber gasket (for Fig. 320)	1	339	W444282	Oil cotton braid holder	1
912	W461789	Oil pipe (for arm shaft) complete	1	340	B503842	Screw (for Fig. 341) 11/64(40) x 4.5	2
322	W321522	Oil pipe (for arm shaft)	1	341	W447762	Oil cotton braid supporter (for Feed bar oiling)	1
323	W500189	Oil pipe sleeve nut (for Fig. 322)	1	342	W444138	Oil cotton braid (for feed bar oiling)	1
913	W461745	Oil pipe (for hook shaft) complete	1				
324	W501135	Oil pipe sleeve nut (for Fig. 325)	1				
325	W321363	Oil pipe (for hook shaft)	1				
326	W450263	Knee lifter lifting rod	1				
327	W502097	Collar (for Fig. 329)	1				

M E M O

A series of horizontal dashed lines for writing.