

MANUAL NO.  
INS9207

ADJUSTING INSTRUCTIONS

STYLES

39500 QA  
39500 QB  
39500 QP  
39500 RA  
39500 RF  
39500 RR  
39500 RS  
39500 SE  
39500 SF  
39500 TE  
39500 CQA  
39500 CQB  
39500 CRF  
39500 SQB  
39500 SRF  
39500 CSRF

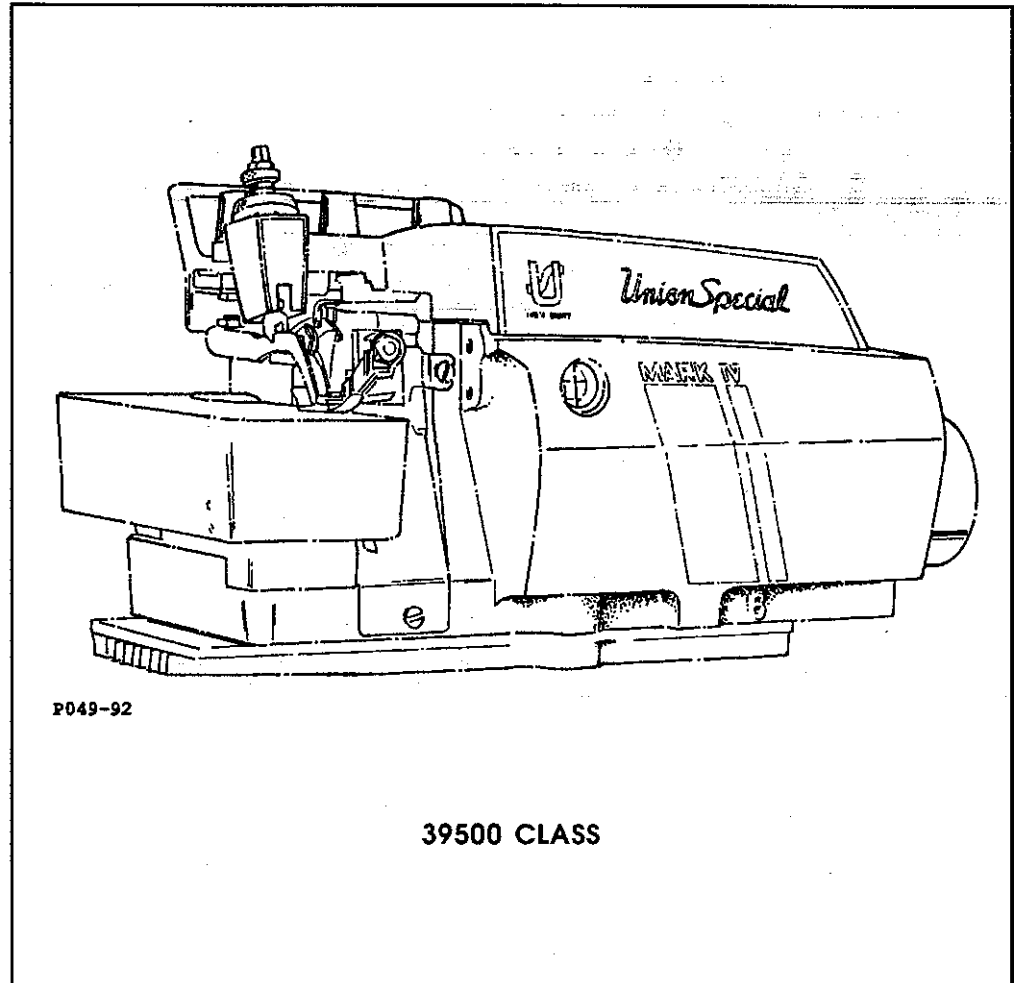

  
Finest Quality

*Union Special*  
INDUSTRIAL SEWING EQUIPMENT

# Manual No. INS9207 for 39500 Series Machines

---

First Edition Copyright 1993

By

Union Special Corporation Rights Reserved In All Countries

Printed in U.S.A. October 1993

---

## PREFACE

This parts manual has been prepared to guide you while adjusting the 39500 Series machines. It can be used in conjunction with Union Special Parts Manual PRT9206.

This manual explains in detail the proper setting for each of the components related to forming the stitch and completing the functions of the machine. Illustrations are used to show the adjustments and reference letters are used to point out specific items discussed.

Careful attention to the instructions for operating and adjusting these machines will enable you to maintain the superior performance and reliability designed and built into every Union Special machine.

Adjustments are presented in sequence so that a logical progression is accomplished. Some adjustments performed out of sequence may have an adverse effect on the function of the other related parts.

This manual has been comprised on the basis of available information. Changes in design and/or improvements may incorporate a slight modification of configuration in illustrations or part numbers.

On the following pages will be found illustrations and terminology used in describing the adjustments for the 39500 Series machines.

---

## SAFETY RULES



### General Operating Directions

The sewing machines described in this instruction manual are prohibited from being put into service until it has been ascertained that the sewing units, in which these sewing machines will be built-in have conformed with the EC Council Directives (89/392/EEC, Annex II B).

1. Before putting the machines described in this manual into service, carefully read the instructions. The starting of each machine is only permitted after taking notice of the instructions and by qualified operators.

**IMPORTANT!** Before putting the machine into service, also read the safety rules and instruction from the motor supplier.

2. Observe the national safety rules valid for your country.
3. Each machine is only allowed to be used as foreseen. The foreseen use of the particular machine is described in paragraph "STYLES OF MACHINES" of this instruction manual. Another use, going beyond the description, is not as foreseen.
4. All safety devices must be in position when the machine is ready for work or in operation. Operation of the machine without the appertaining safety devices is prohibited.
5. The following safety devices are components of the sewing machines: Sewing guard, needle lever eyelet guard, needle bar guard, needle break protection shield and handwheel-belt guard.
6. When gauge parts are exchanged (e.g. needle, presser foot, needle plate, feed dog and bobbin) during threading, when the operator leaves the workplace, and during service work, the machine must be isolated from the main power by switching off the main switch or disconnecting the main plug. On mechanically operated clutch motors without a start inhibitor it is necessary to wait until the motor has stopped.

7. Wear safety glasses.
8. In case of machine conversions and changes all valid safety rules must be considered. Conversions and changes are made at your own risk.
9. Commissioning of the sewing head is prohibited until such time as the entire sewing unit is found to comply with EC regulations.
10. The warning hints in the instructions are marked with one of these two symbols:



Items require special attention



Danger of injury to operative or service staff

Be sure to observe and adhere to these indications and to the generally applicable regulations.

#### Special Operating Directions

11. For the following the machine has to be disconnected from the power supply by turning off the main switch or by pulling out the main plug:
  - 11.1 For threading needle(s), looper, spreader etc.
  - 11.2 For replacing sewing parts such as needle, presser foot, throat plate, looper, spreader, feed dog, needle guard, folder, fabric guide etc.
  - 11.3 When leaving the workplace and when the workplace is unattended.
  - 11.4 For maintenance work.
  - 11.5 When using clutch motors without actuation lock, wait until the motor is stopped totally.

#### General Maintenance Directions

12. Maintenance, repair and conversion work (see item 8) must be done only by trained technicians or special skilled personnel under consideration of the instructions.
13. Any work on the electrical equipment must be done by an electrician or under direction and supervision of special skilled personnel.

#### Special Maintenance Directions

14. Work on parts and equipment under electrical tension is not permitted. Permissible exceptions are described in the applicable sections of standard sheet DIN VDE 0105.
15. Before doing maintenance and repair work on the pneumatic equipment, the machine has to be disconnected from the compressed air supply. In case of existing residual air pressure after disconnecting from compressed air supply (e.g. pneumatic equipment with air tank), the pressure has to be removed by bleeding.

Exceptions are only allowed for adjusting work and function checks done by special skilled personnel.

#### Standards

17. The sewing machines described in this manual are built according to the following standards:

EN292-2 Safety of machinery-basic concepts, general principles for design.

IEC204-3-1/EN60204-3-1 Electrical equipment of industrial machines. Part 3: Particular requirements for sewing machines, units and systems.

## CONTENTS

• IDENTIFICATION OF MACHINES .....	4
• TORQUE REQUIREMENTS .....	4
• DESCRIPTION OF MACHINES .....	5
• MACHINE STYLES .....	5
• MACHINE STYLES (CONT.) .....	6
• NEEDLES .....	6
• DESCRIPTION .....	6
• FEED ECCENTRICS .....	6
• THREADING .....	7
• TO THREAD THE LOWER LOOPER .....	7
• TO THREAD UPPER LOOPER (504 AND 505 STITCH ONLY) .....	7
• 504 STITCH .....	8
• 503 STITCH .....	9
• 505 STITCH .....	10
• TO THREAD THE NEEDLE .....	11
• OILING .....	11
• ADJUSTING INSTRUCTIONS .....	11
• CENTERING THE THROAT PLATE TO THE FEED DOGS .....	11
• CENTERING THE NEEDLE TO THE THROAT PLATE .....	12
• SETTING THE NEEDLE HEIGHT .....	12
• SETTING THE LOWER LOOPER .....	12
• PRE-SETTING THE LOWER KNIFE .....	13
• SETTING THE UPPER LOOPER/SPREADER .....	13
• SETTING THE UPPER LOOPER SPREADER (CONT.) .....	14
• SETTING THE REAR NEEDLE GUARD .....	14
• SETTING THE FRONT NEEDLE GUARD .....	14
• SETTING THE FEED DOG TILT .....	15
• SETTING THE FEED DOG HEIGHT .....	15
• FINAL SETTING FOR THE LOWER KNIFE .....	15
• SETTING THE UPPER KNIFE .....	15
• SETTING THE UPPER KNIFE .....	16
• PRESSER FOOT ALIGNMENT .....	16
• SETTING THE PRESSER FOOT LIFT .....	16
• PRESSER FOOT PRESSURE .....	16
• SETTING THE STITCH LENGTH .....	17
• STARTING TO OPERATE (503 AND 504 STITCH) .....	17
• NEEDLE THREAD CONTROL (503 AND 504 STITCH) .....	17
• LOWER LOOPER THREAD CONTROL (503 STITCH) .....	17
• LOWER LOOPER THREAD CONTROL (504 STITCH) .....	17
• LOWER LOOPER THREAD CONTROL (504 STITCH) (CONT.) .....	18
• UPPER LOOPER THREAD CONTROL (504 STITCH) .....	18
• POSITIONING THE PURL (504 STITCH) .....	18
• THREAD TENSIONS (503 STITCH) .....	18
• THREAD TENSIONS (504 STITCH) .....	18
• STARTING TO OPERATE (505 STITCH) .....	18
• NEEDLE THREAD CONTROL (505 STITCH) .....	18
• LOWER LOOPER THREAD CONTROL (505 STITCH) .....	19
• UPPER LOOPER THREAD CONTROL (505 STITCH) .....	19
• POSITIONING THE SQUARE EDGE (505 STITCH) .....	19
• POWER AIR-KLIPP® CHAIN CUTTER ADJUSTMENTS .....	19
• SETTING KNIFE CUTTING .....	19
• SETTING KNIFE PRESSURE .....	20
• SETTING PRESSURE VALVES .....	20
• REMOVING THE CRANKSHAFT .....	20
• REMOVING THE CRANKSHAFT (CONT.) .....	21
• NOTES .....	22

### IDENTIFICATION OF MACHINES

Each Union Special machine is identified by a style number, which on this machine class is stamped into a style plate affixed to the rear of the machine on the left side. The serial number is stamped into the base of the casting below the style plate.

### TORQUE REQUIREMENTS

Torque (measured in inch-pounds) is a rotating force in pounds applied through a distance by a lever (in inches or feet). This is accomplished by a wrench, screwdriver, etc. Many of these devices are available, which when set at the proper amount of torque will tighten the part to the correct amount and no tighter.

All straps and eccentrics should be tightened to 26-28 inch-pounds (2.9-3.2Nm) unless otherwise noted. All other nuts, bolts, screws, etc. should be tightened by hand as tightly as possible, unless otherwise noted.

Screws requiring a specific torque will be indicated on the illustrations in 39500 Parts Manual PRT9206.

## DESCRIPTION OF MACHINES

MARK IV high speed, single curved blade needle, two looper-three thread or one looper, one spreader-two thread machine, cam adjusted main and differential feeds, trimming mechanism with spring pressed lower knife, automatic lubricating system and air cooling system.

### MACHINE STYLES

- 39500 QA** Low Throw Machine for seaming light and medium weight, flat, and warp tricot, rayon and silk fabrics or similar weight synthetics. This sewing combination has been designed especially for use on women's and children's slips, pajamas, nightgowns or similar articles where long straight hanging seams are a primary requisite. Standard seam widths are 3/32" and 1/8" (2.38mm and 3.17mm). Seam 504, SSa-1. 8000 R.P.M..
- 39500 QB** Low Throw Machine for seaming light and medium weight flat, warp and ribbed knit cotton, rayon and silk fabrics or similar weight synthetics. This sewing combination has been designed for general purpose seaming of "T" shirts, polo shirts, panties, infant and children's knit wear and similar garments. Standard seam widths are 3/32", 1/8" and 5/32" (2.38mm, 3.17mm and 4.0mm). Seam 504, SSa-1. 8000 R.P.M..
- 39500 QP** High Throw Machine for seaming medium to heavy weight flat, warp and ribbed knit cotton, wool, rayon and silk fabrics. This sewing combination has been designed for sweat shirts, snow suits, underwear and similar garments. Standard seam width is 1/8" (3.17mm). Seam 504, SSa-1, 7500 R.P.M..
- 39500 RA** High Throw Machine for seaming medium to heavy knit outerwear made from cotton, wool and synthetic yarns with provisions for inserting reinforcing tape used on shoulder seams of sweaters and similar garments. Standard seam width is 5/32" (4.0mm). Seam 504, SSa-1, 7500 R.P.M..
- 39500 RF** High Throw Machine for seaming all types and weights of flat, warp and ribbed knit cotton, wool, rayon and silk fabrics. Produces the same garments as Style 39500 QP except fitted with 39500 QB sewing parts. Standard seam widths are 3/32", 1/8" and 5/32" (2.38mm, 3.17mm and 4.0mm). Seam 504, SSa-1. 7500 R.P.M..
- 39500 RR** High Throw Machine for break open seaming and attaching elastic to girdles and foundation garments using a two or three thread stitch. The trimming knives may or may not be used. A front fabric guide is included if the material is not to be trimmed. Standard seam width is 1/4" (6.35mm). Seam 503 or 505, SSa-1 open to LSa-1. 7500 R.P.M..
- 39500 RS** Low Throw Machine for seaming light to medium weight turned - down hems on pajamas, negligees, peignoirs, blouses and similar sheer garments requiring reinforced seams. Standard seam width is 3/32" (2.38mm). Seam 504, EFe-1 inv. 8000 R.P.M..
- 39500 SE** Low Throw Machine for seaming and attaching light to medium weight collarettes to "T" shirts. Prepared to accept Jesse Heap folder No. U-100. Standard seam width is 1/8" (3.17mm). Seam 504, SSa-1. 8000 R.P.M..
- 39500 SF** High Throw Machine for seaming Bulky knit sweaters. A reinforcing tape automatically guided by a slot in the presser foot may be attached to the shoulder seams of sweaters. Uses straight knife parts. Standard seam width is 1/8" (3.17mm). Seam 504, SSk-1. 7500 R.P. M..
- 39500 TE** Low Throw Machine for seaming fine synthetic knitwear. Standard seam width is 1/8" (3.17mm). Seam 504, SSa-1. 8000 R.P.M..
- 39500 CQA** Same as Style 39500 QA except equipped with power Air-Klipp®. Standard seam width is 1/8" (3.17mm).
- 39500 CQB** Same as Style 39500 QB except equipped with power "Air-Klipp". Standard seam width is 1/8" (3.17mm).
- 39500 CRF** Same as Style 39500 RF except equipped with power "Air-Klipp". Standard seam width is 1/8" and 5/32" (3.17mm and 4.0mm).

## MACHINE STYLES (CONT.)

- 39500 SQB** Same as Style 39500 QB except uses a short needle. Standard seam width is 1/8" (3.17mm).
- 39500 SRF** Same as Style 39500 RF except uses a short needle. Standard seam widths are 3/32", 1/8" and 5/32" (2.38mm, 3.17mm and 4.0mm).
- 39500 CSRF** Same as Style 39500 SRF except fitted with power "Air-Klipp". Standard seam widths are 1/8" and 5/32" (3.17mm and 4.0mm).

## NEEDLES

Each Union Special needle has both a type and size number. The type number denotes the kind of shank, point, length, groove, finish and other details. The size number, stamped on the needle shank, denotes the largest diameter of the blade midway between the shank and the eye. Collectively, the type number and size number represent the complete symbol which is given on the label of all needles packed and sold by Union Special.

### DESCRIPTION

- 154 ZA** Round shank, round point, curved blade, standard length, double groove, struck groove, spotted, chromium plated. Size available 075/029.
- 154 GAS** Round shank, round point, curved blade, standard length, single groove, struck groove, spotted, chromium plated. Sizes available 065/025, 070/027, 075/029, 080/032, 090/036, 100/040, 110/044, 125/049, 140/054, 150/060.
- 154 GHS** Round shank, round point, curved blade, standard length, single groove, ball point, spotted, chromium plated. Sizes available 065/025, 070/027, 075/029, 080/032, 090/036.
- 162 SAS** Round shank, round point, curved blade, short length, single groove, struck groove, spotted, chromium plated. Sizes available 055/022, 065/025, 070/027, 075/029, 080/032, 090/036, 100/040, 110/044.

Machine Style	Needle Type	Needle Size
39500 QA, QB, RF, TE, CQA, CQB, CRF	154 GAS or 154 ZA	070/027
39500 SE	154 GAS or 154 ZA	080/032
39500 QP	154 GAS or 154 ZA	090/036
39500 RA, SF	154 GAS or 154 ZA	100/040
39500 RS	154 GBS or 154 ZA	075/029
39500 RR	154 GHS or 154 ZA	080/032
39500 SRF, CSRF	162 SAS	065/025
39500 SQB	162 SAS	070/027

Table I

Refer to Table I for the recommended needle type and size of each machine style.

When changing the needle, make sure it is fully inserted in the needle driving arm before the needle clamp nut stud is tightened.

To have needles promptly and accurately filled, an empty package, a needle sample, or the type and size number should be forwarded. Use the description on the label. A complete order should read as follows: "100 needles, type 154 GAS, size 070/027".

## FEED ECCENTRICS

Various feed eccentrics are used in the 39500 series machines to produce desired stitches per inch.

Two feed eccentrics are supplied with each machine, however, additional eccentrics may be ordered separately. Feed eccentric stitch sizes available are as follows: 4, 5, 6, 7, 8, 9, 10, 11, 12, 13, 14, 15, 16, 18, 20, 22, 24, 26, 28, 30, 32, 34, 36, 40, 50, 60, 70, 75, and 100. When ordering an eccentric use No. 39540B followed by one of the numbers listed on Table II to indicate the number of stitches desired. Example: "39540B-12".

Machine Style	Differential Feed Driving Eccentric	Main Feed Driving Eccentric
39500 QA, CQA	39540 B-12	39540 B-10
39500 QB, QP, RF, TE, CQB, CRF, SQB, SRF, CSRF	39540 B-10	39540 B-12
39500 RA	39540 B-6	39540 B-10
39500 RR	39540 B-18	39540 B-20
39500 RS	39540 B-14	39540 B-14
39500 SE	39540 B-12	39540 B-9
39500 SF	39540 B-4	39540 B-10

Table II

## THREADING

Only parts involved in threading are shown in threading diagrams (Fig. 1, 2, and 3). Parts are placed in their relative positions for clarity.

It will simplify the threading of these machines to follow the recommended sequence of threading the lower looper first and the needle second when using the 503 stitch (Fig. 2). The recommended sequence when using the 504 or 505 stitch (Fig. 1 and 3) is to thread the lower looper first, upper looper second, and the needle third.

Before threading, swing the cloth plate open and turn the handwheel in operating direction until needle (L) is at its highest position. Release the pressure on the presser foot by turning presser foot release bushing (T) and swing presser arm (H) out of position.

As the threads pass through tension thread guide (A), make sure they pass tension disc (U) and are seated in tension post slot (V).

### TO THREAD THE LOWER LOOPER

Double the end of the thread and lead it through the right eyelet of front thread guide (B, Fig. 1, 2, or 3) and through both eyes of lower looper thread eyelet (E) from right to left.

**Note:** Thread must pass in front of looper thread pull-off (S). Lead the thread behind fabric guard (F) and through frame looper thread guide (G). Turn handwheel in operating direction until heel of lower looper (J) is all the way to the left, then thread through both eyes from left to right.

**Note:** In Fig. 3 for the 505 stitch, the lower looper thread eyelet is placed in the upper position.

### TO THREAD UPPER LOOPER (504 AND 505 STITCH ONLY)

Thread upper looper thread through left eyelet of front thread guide (B). Then turn handwheel until point of upper looper (K) is all the way left. Lead thread through auxiliary looper thread eyelet (D) from back to front, then through both eyes of upper looper thread eyelet (C) from left to right.

**Note:** Thread must pass in front of looper thread pull-off (S). (After pulling up upper looper thread tube assembly (M)) lead thread under neck of top cover casting and down through thread tube assembly (M). Pull thread out bottom of tube; push tube down, then insert thread through upper looper eye from front to back.

**Note:** In Fig. 3 for the 505 stitch, the upper looper thread eyelet is placed in the lower position.

**Caution:** Be sure the upper looper thread is under the lower looper thread when passing from tube assembly to upper looper eye.

504 STITCH

for Styles 39500 QA, QB, QP, RA, RF, RS, SE, SF, TE, CQA, CQB, CRF, SQB, SRF, CSRF

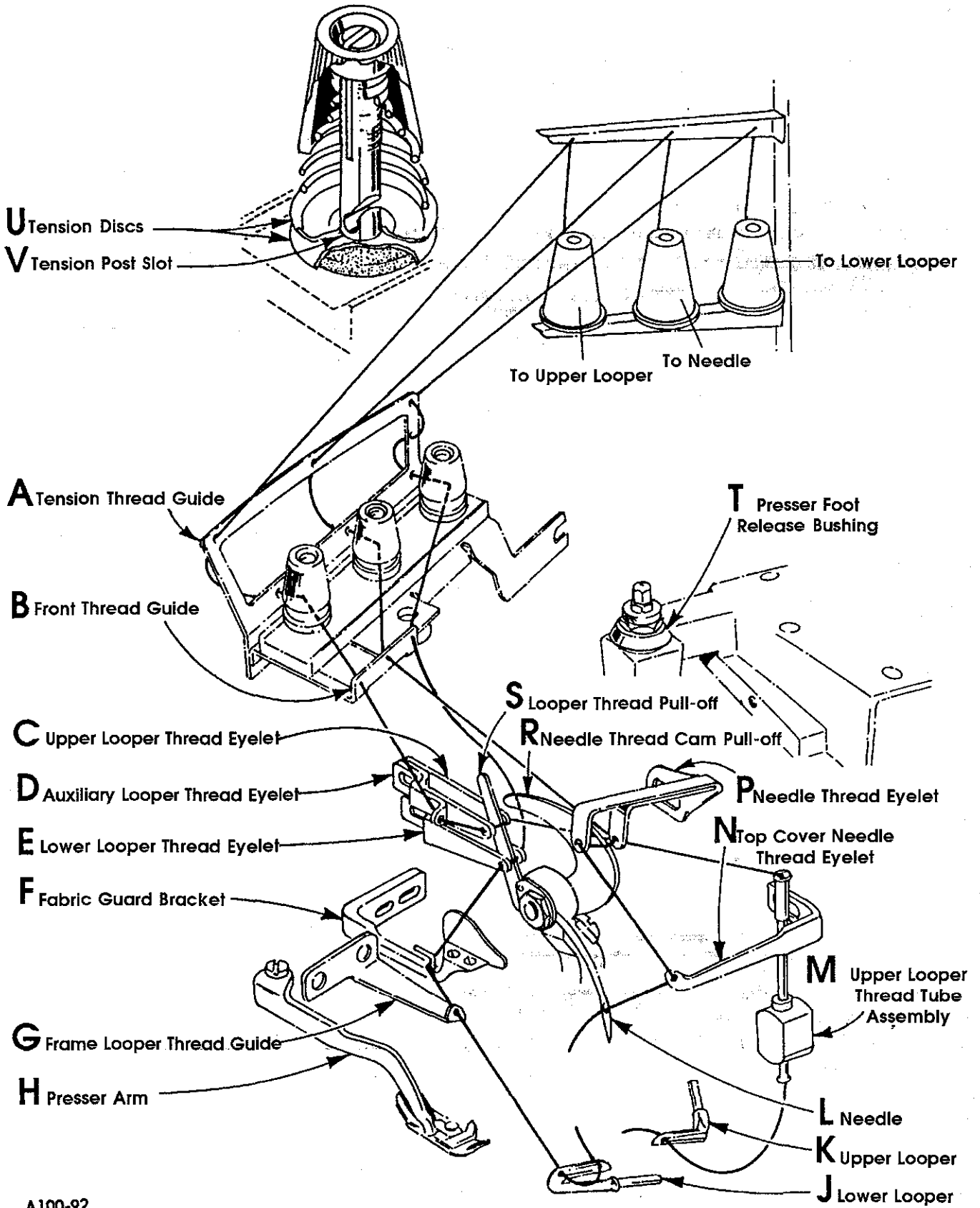

A100-92

Fig. 1



503 STITCH  
for Style 39500 RR

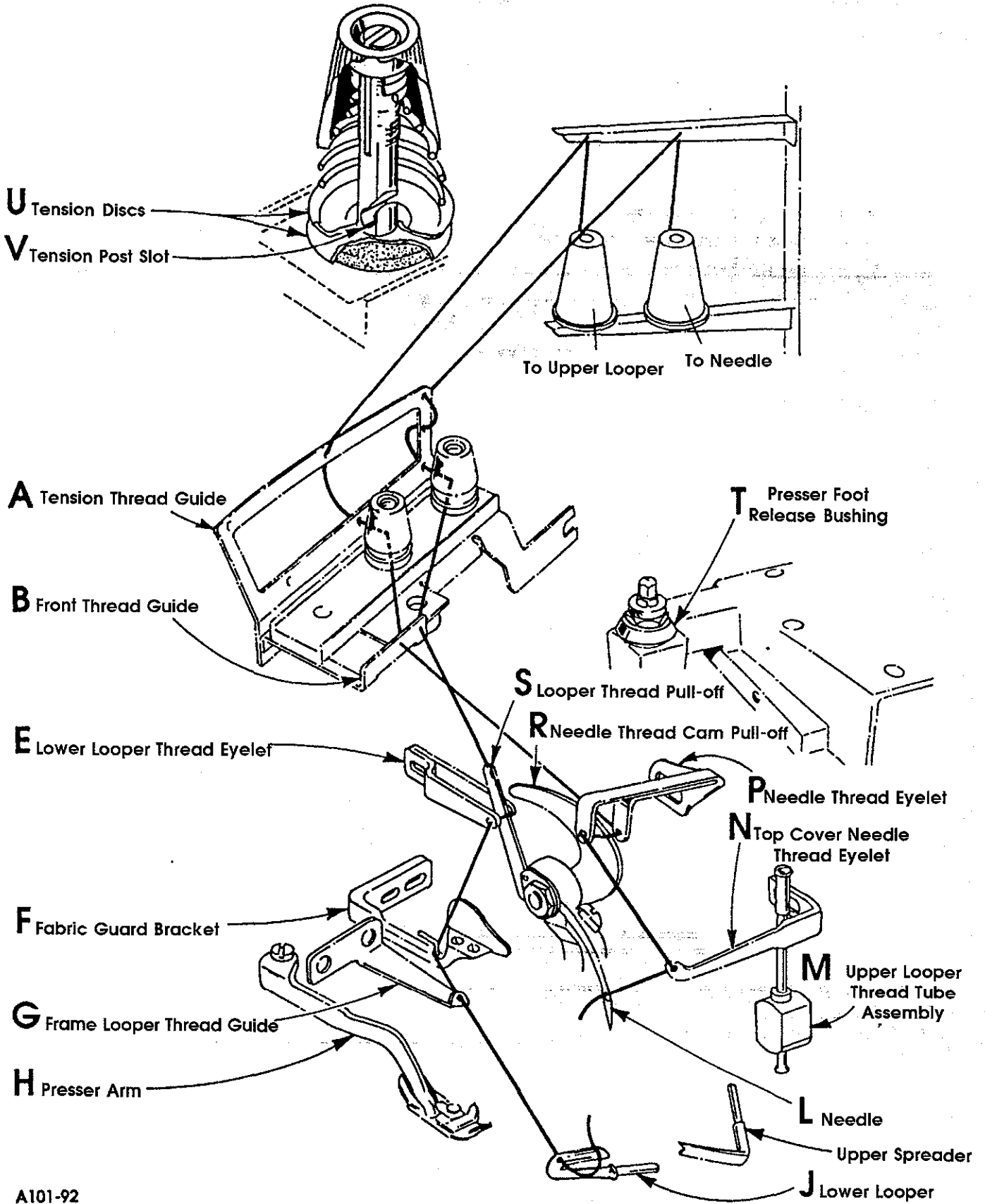

A101-92

Fig. 2

505 STITCH  
For Style 39500 RR

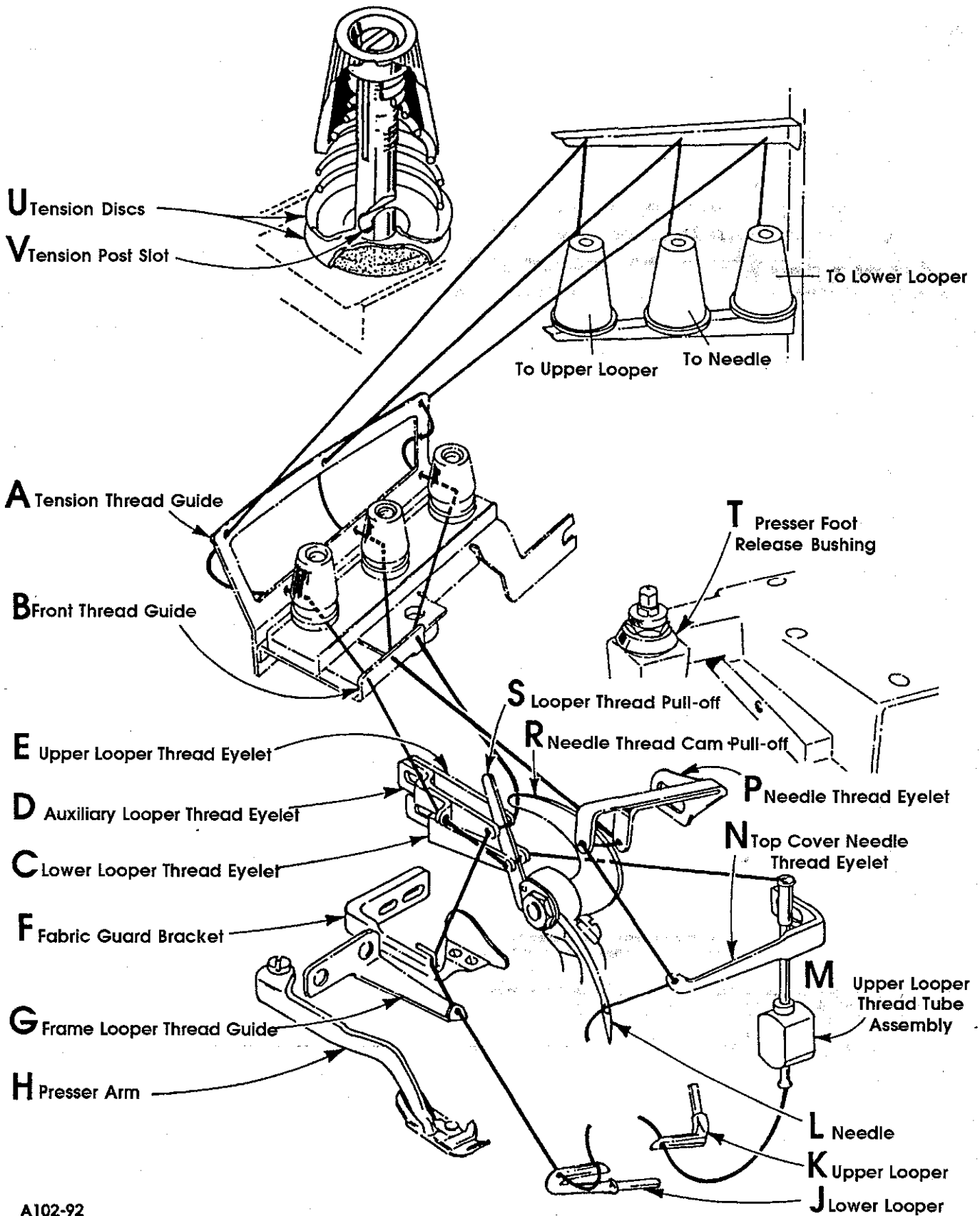

A102-92

Fig. 3

## TO THREAD THE NEEDLE

Thread needle thread through middle eyelet of front thread guide (B). Turn handwheel in operating direction until needle (L, Fig. 1, 2, or 3) is at its highest position. Insert needle thread from right to left, through both eyes of needle thread eyelet (P), under neck of the top cover casting; the down through hole in top cover needle thread eyelet (N). Thread the needle from the front. Lower needle thread eyelet (P) so needle thread cam pull-off (R) just contacts the needle thread.

## OILING

Oil is drained from these machines before they are shipped so the reservoir must be filled before operation begins.

Referring to Fig. 4, fill the machine at spring cap (A). Use a straight mineral oil, Saybolt viscosity of 90 to 125 seconds at 100° Fahrenheit. This is equivalent to Union Special Specification No. 175. Check the oil level at sight gauge (B) when the machine is level & stationary. The red tip on the oil indicator should show between the two lines on oil sight gauge (B).

This machine is automatically lubricated. No oiling is necessary, other than keeping main reservoir filled. Check oil daily before the morning start; add oil as required, but DO NOT over fill.

To maintain maximum recommended speed and servcability of this equipment when operating continuously, the oil must be changed at least every six months. In no case should oil remain in machine for more than one year.

The drain plug screw is located at the back of the machine near the base. It is a magnetic screw designed to accumulate possible foreign materials which may have entered the crank case. It should be removed and cleaned periodically.

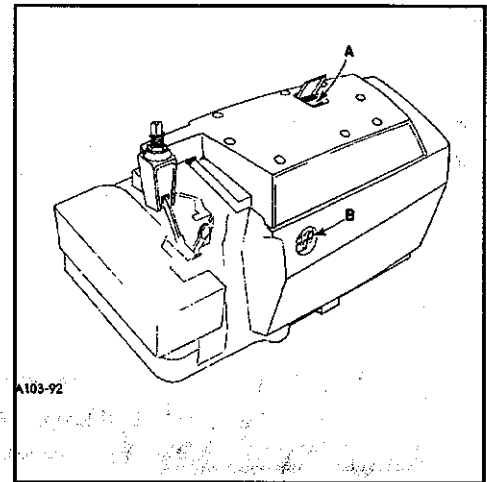

Fig. 4

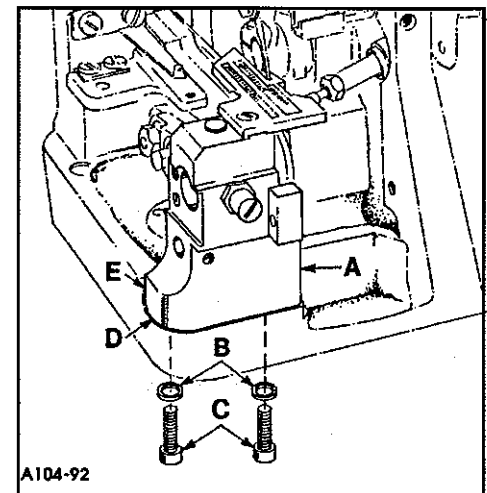

Fig. 5

## ADJUSTING INSTRUCTIONS

Instructions stating direction or location, such as right, left, front or rear of the machine are given relative to the operator's position at the machine unless otherwise noted. The hand-wheel rotates clockwise in operating direction.

### CENTERING THE THROAT PLATE TO THE FEED DOGS

After attaching the feed dogs to the feed bars, fasten support block (A, Fig. 5) with attached throat plate to the machine bed using washers (B) and screws (C). Place shim (D) between block (A) and machine bed on style 39500 SE 1/8 only. Make sure the back of the block is tight against casting wall (E). Position the block to the right or left until there is an equal amount of space between the feed dogs and the sides of the throat plate slots. Tighten screws (C).

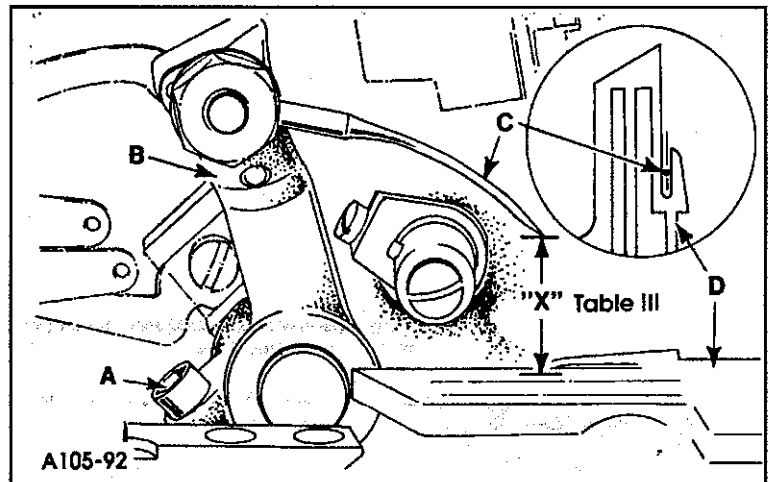

Fig. 6

Machine Style	"x" Dimension	
	Inches	Millimeters
39500		
QA, QB, QP, RF, RS, TE, CQA, CQB, CRF, SQB, CSRF	1/2 ±1/64	12.7 ± 0.4
RA, RR, SE, SF	15/32 ±1/64	11.9 ± 0.4

Table III

### CENTERING THE NEEDLE TO THE THROAT PLATE

The needle must be centered from right to left in the needle slot of the throat plate. If adjustment is necessary, loosen screw (A, Fig. 6) and reposition needle driving arm (B) right or left to center needle (C) in

needle slot of throat plate (D). Temporarily tighten screw (A).

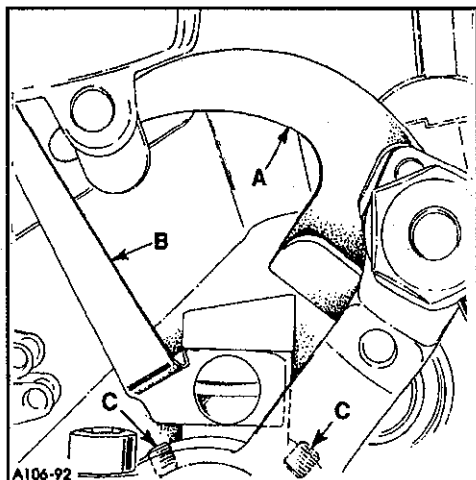

Fig. 7

If adjustment is necessary, loosen screw (A, Fig. 6) and move arm (B) forward or rearward as required being careful not to disturb the right to left needle alignment. Tighten screw (A).

If needle thread cam pull-off (A, Fig. 7) overlaps looper thread pull-off (B) loosen screws (C) and move pull-off (B) to the rear. There should be a small amount of clearance between cam (A) and pull-off (B). Tighten screws (C) making sure to take up end play in the needle driving arm.

### SETTING THE NEEDLE HEIGHT

Turn the handwheel in operating direction until needle driving arm (B, Fig. 6) is at its highest position. At this time, the distance from the tip of needle (C) to the surface of throat plate (D) should be within the "X" dimension listed on Table III.

### SETTING THE LOWER LOOPER

Remove the throat plate and the feed dogs. Turn the handwheel in operating direction until the lower looper shaft (A, Fig. 8) is at its extreme left travel. Insert lower looper (B) and snug nut (C) just enough so the looper can still be moved. Position the looper so the distance from the point of the looper to the centerline of the needle is 1/8" (3.18mm). Looper gauge 21225-1/8 may be used to make this adjustment.

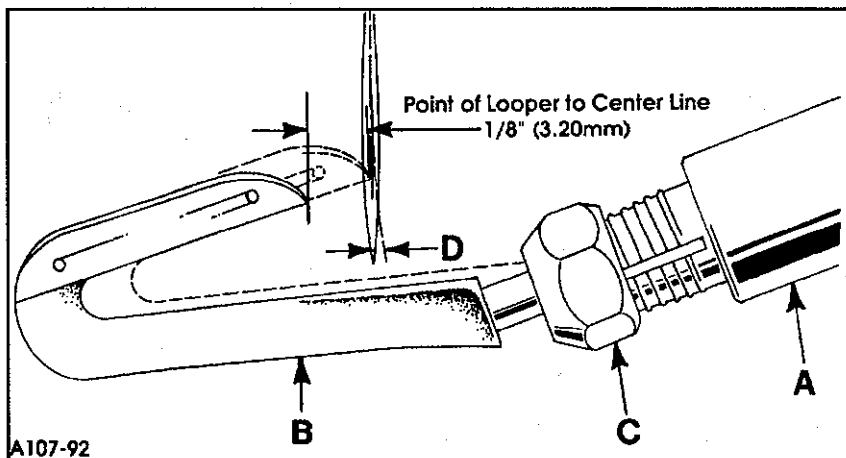

Fig. 8

As the lower looper passes the back of the needle, the looper point should deflect the needle within the range listed in Table IV

Style	Range of Deflection (D)	
	Inches	Millimeters
39500 QA, QB, QP, RF, RS, SE, TE, CQA, CQB, CRF, SQB, SRF, CSRF	.001 to .002	.03 to .05
39500 RA, RR, SF	.002 to .006	.05 to .15

Table IV

Tighten nut (C, Fig. 8) and recheck the above settings.

## PRE-SETTING THE LOWER KNIFE

By pre-setting the lower knife, you will avoid interference with the needle guards in future adjustments.

Attach throat plate (A, Fig. 9) to support block (B). Assemble lower knife (C) to lower knife holder (D) and insert in lower knife support block (B). The cutting edge of lower knife (C) should be flush with and parallel to the throat plate surface. Loosen screw (E) and move the lower knife up or down until it is flush with the throat plate surface. Tighten screw (E).

If the cutting edge of the knife is tilted, loosen screw (F) and rotate holder (D) until the knife edge is parallel to the throat plate surface. Tighten screw (F).

Leave the lower knife holder in the support block while setting the needle guards.

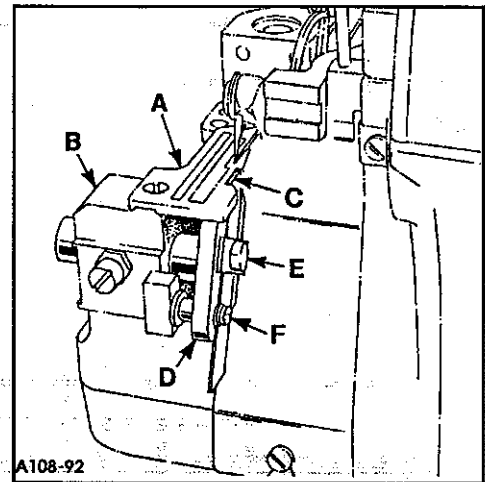

Fig. 9

## SETTING THE UPPER LOOPER/SPREADER

Figures 10, 11, 12, and Table V relate approximate dimensions for adjusting the upper looper/spreader at their extreme right and left positions of travel. Follow the instruction below in the sequence listed.

1. Position upper looper/spreader at the left end of travel, loosen clamp screw (A, Fig. 10) and set the upper looper/spreader shank to the "B" dimension on Table V. Temporarily tighten screw (A).
2. On all styles using the 504 or 505 stitch position the upper looper at the right end of travel. Loosen screw (C) and rotate holder (D) as required to set shank slightly back of vertical as shown in Fig. 10. Temporarily tighten screw (C). On style 39500 RR (503 stitch) set the spreader shank vertical.
3. Rotate the handwheel in operating direction. As the looper/spreader (E, Fig. 11) moves from right to left, the point of the upper looper or the thread pick-up of the upper spreader must pass behind the notch of lower looper (F) with a .002" (.05mm) clearance.

Moving toward the top of the stroke, the heel of the upper looper/spreader should pass behind the lower looper head with a 1/64" to 1/32" (.40mm to .79mm) clearance.

At the extreme right end of travel, be sure there is clearance between the heel of the looper/spreader and the casting.

4. Continue to rotate the handwheel in operating direction until the looper/spreader is at its extreme left end of travel. At this time the distance between the throat plate surface and the point of the upper looper or the lower point of the spreader should be the "G" dimension on Fig. 12 and Table V. Loosen screw (H) and move looper (J) or spreader (K) up or down as required. Tighten screw (H).

5. Leave the looper/spreader positioned at the left end of travel. The distance between the centerline of the needle and the point of the upper looper or the lower point of the spreader should be the "L" dimension on Fig. 12 and Table V. Loosen screw (C, Fig. 10) and adjust holder (D) right or left as required. Tighten screw (C).

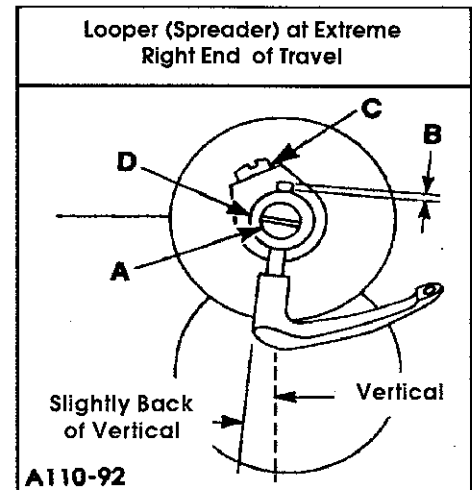

Fig. 10

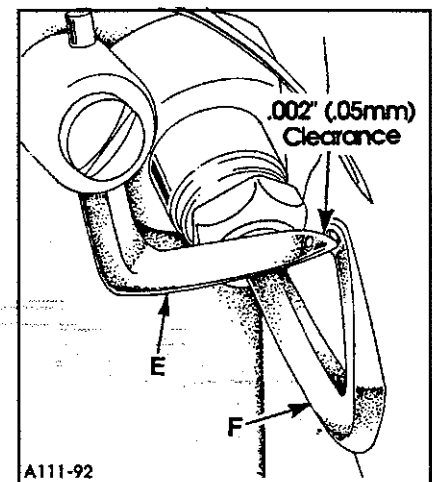

Fig. 11

## SETTING THE UPPER LOOPER SPREADER (CONT.)

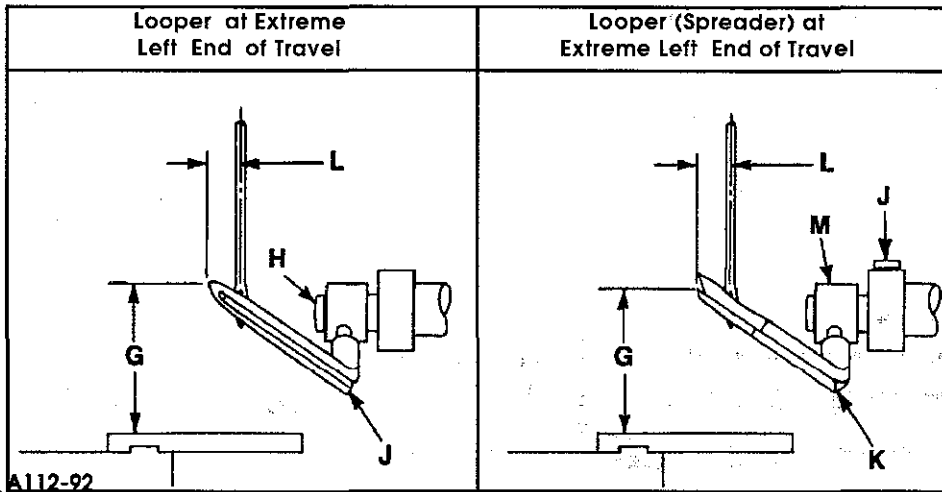

Fig. 12

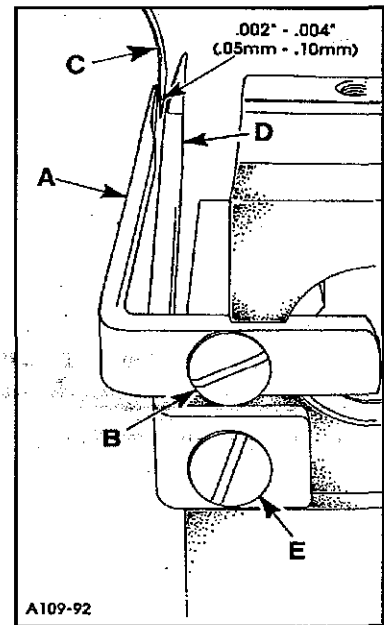

Fig. 13

6. If the needle is being deflected by the upper looper/spreader, clearance to the needle can be increased by reducing the distance between the looper/spreader shank and the holder (B, Fig. 10). It will then be necessary to slightly reduce the angle of the shank back of vertical (see step 2). Set looper/spreader to lower looper (see step 3). Reversing this procedure will position looper/spreader closer to the needle.

Machine Style	Shank Extended Above Holder		Height Above Throat Plate		Point to Left of Needle Centerline	
	Inches	Millimeters	Inches	Millimeters	Inches	Millimeters
39500	"B" Fig. 11		"G" Fig. 13		"L" Fig. 13	
QA, QB, RS, TE, CQA, CQB, SQB	1/32 ± 1/32	.8 ± .8	31/64 ± 1/64	12.3 ± .4	5/32 + 1/64	4.0 +.4
RA, RR, SF, CRF	1/16 ± 1/32	1.6 ± .8	15/32 ± 1/64	11.9 ± .4	9/64 + 1/64	3.6 +.4
QP, RF, SE, SRF, CSRF	1/64 ± 1/64	.4 ± .4	1/2 ± 1/64	12.7 ± .4	9/64 + 1/64	3.6 +.4

Table V

### SETTING THE REAR NEEDLE GUARD

Remove the throat plate and attach rear needle guard (A, Fig. 13) to the lower knife support block with screw (B). Set the guard dead against needle (C) when the needle is being deflected forward by the point of the lower looper; As outlined in Table IV. This will allow the looper to pass the back side of the needle without deflecting it but also maintains minimum clearance. The rear needle guard maintains the looper-needle relationship at loop taking time. The position of the guard should not interfere with the lower looper or movement of the lower knife holder.

### SETTING THE FRONT NEEDLE GUARD

Turn the handwheel in operating direction until the needle is resting on the rear needle guard and the looper point is behind the needle. Attach front needle guard (D, Fig. 13) to the lower knife holder block with screw (E). There should be a clearance of .002" to .004" (.05mm to .10mm) between the needle and the front needle guard. There should be no interference between the front needle guard and the differential feed dog.

Remove the lower knife holder.

### SETTING THE FEED DOG TILT

Reassemble feed dogs (A, Fig. 14) and throat plate (B). Rotate the handwheel in operating direction until the feed dogs start to rise above the throat plate. The teeth of the main and differential feed dogs should be level with each other and parallel to the throat plate.

If adjustment is necessary, loosen screw (C) and rotate tilt adjusting pin (D) as required. This simultaneously tilts the back end of the feed bars up or down. Tighten screw (C).

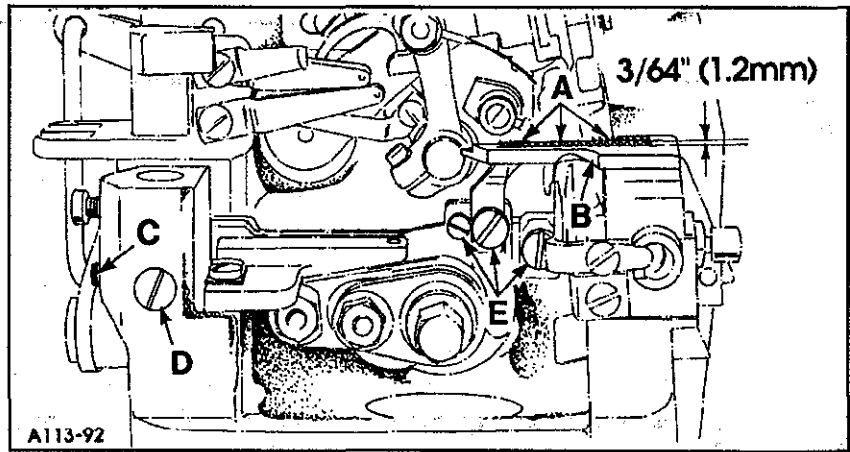

Fig. 14

### SETTING THE FEED DOG HEIGHT

Turn the handwheel in operating direction until the feed dogs are at their highest point of travel. Loosen screws (E, Fig. 14) and set each feed dog to the height listed on Table VI.

Machine Style	Chaining Feed Dog		Main/Differential Feed Dogs Distance Above Throat Plate Surface	
39500 QA, CQA	1/64"	.4mm	3/64"	1.2mm
	Below Throat Plate Surface			
39500 QB, QP, RA, RF, RR, SE, SF, CRF, SQB, SRF, CSRF	Flush with Throat Plate Surface		3/64"	1.2mm
39500 RS	3/64"	1.2mm	3/64"	1.2mm
	Above Throat Plate Surface			
39500 TE			3/64"	1.2mm

Table VI

### FINAL SETTING FOR THE LOWER KNIFE

Insert the spring into lower knife holder (A, Fig. 15) and insert into support block (B). Set the knife to the specified seam width by measuring from the center of the needle to the cutting edge of the lower knife. Hold the knife holder in this position and tighten screw (C).

### SETTING THE UPPER KNIFE (FOR ALL STYLES EXCEPT 39500SF)

Turn handwheel in operating direction until upper knife driving arm (D, Fig. 15) is at its highest point of travel. Insert upper knife clamp stud and holder (E) into upper knife driving arm slot. Turn handwheel in operating direction until knife in driving arm is at its lowest position and place upper knife holder slot (F) holding it firmly against lower knife (G). At this time the front cutting edge of the upper knife should be 1/64" to 1/32" (.4mm to .8mm) below the cutting edge of the lower knife. If adjustment is necessary, slide upper knife holder (E) right or left until knife placement is correct and tighten screw (H).

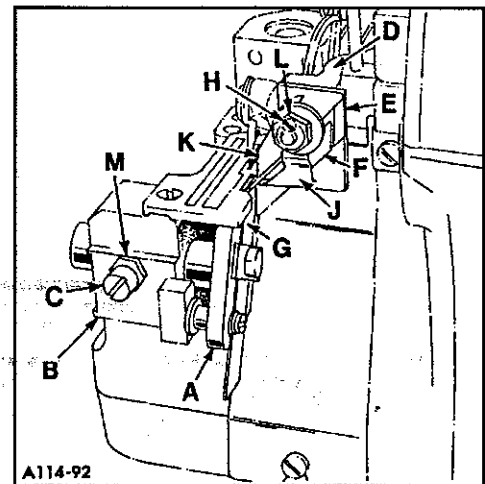

Fig. 15

Assemble knife clamp (J) and chain guard (K) in position using nut (L). Set chain guard (K) against top surface of upper knife and slightly back of its cutting edge, then tighten nut (L). Loosened screw (C) to enable spring pressed lower knife to move freely left to right.

Tighten nut (M) to hold screw (C) in position. Screw (C) also serves as a latch pin for the cloth plate.

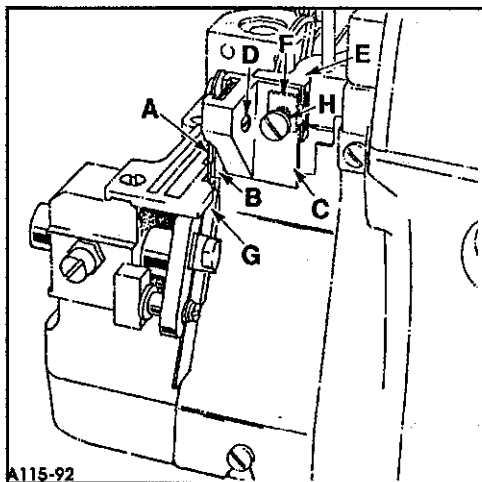

Fig. 16

### SETTING THE UPPER KNIFE (FOR STYLE 39500SF)

Insert upper knife (A, Fig 16) and clamp bar (B) into upper knife holder (C) and snug screw (D). Turn handwheel in operating direction until upper knife driving arm (E) is at its lowest point of travel. Insert upper knife clamp nut (F) and upper knife holder (C) into upper knife driving arm slot holding it firmly against lower knife (G). Position the front cutting edge of the upper knife so it is  $1/64$ " to  $1/32$ " (.4mm to .8mm) below the cutting edge of the lower knife. Tighten screw (D). Slide upper knife holder (C) right or left until the desired seam width is achieved and tighten screw (H).

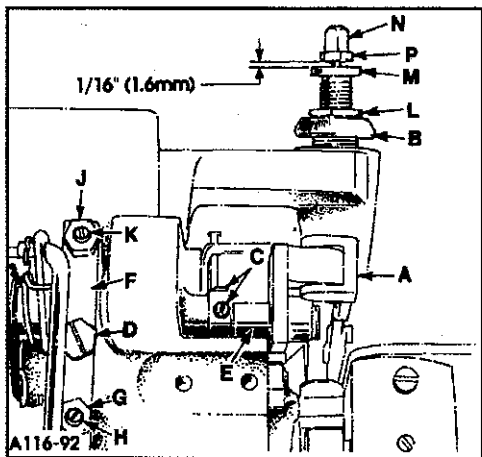

Fig. 17

### PRESSER FOOT ALIGNMENT

Position presser arm (A, Fig. 17) in sewing position and lock in place by turning release bushing (B).

The presser foot must be aligned with the throat plate needle slot and sit flat on the throat plate surface

If adjustment is necessary, loosen screws (C and D) and adjust shaft (E) right or left until the right edge of the presser foot aligns with the left edge of the throat plate needle slot (See A, Fig. 18). Tighten screws (C and D). Make sure lifter lever arm (F) is in a vertical position when screw (D) is tightened and that presser arm (A) does not bind when release bushing (B) is unlocked. Loosen screw (B, Fig. 18) and adjust stitch tongue (C) right to left, to center over the throat plate stitch tongue. Tighten screw (B).

### SETTING THE PRESSER FOOT LIFT

Loosen nut (G, Fig. 17) and adjust lifter lever stop screw (H) so the presser foot will not contact the needle driving arm or the upper looper/spreader at any point of travel when the foot lifter lever is completely depressed. Tighten nut (G). Loosen nut (J) and set stop screw (K) so there is approximately  $1/16$ " (1.6mm) free motion in the lifter lever before the presser foot starts to rise. Tighten nut (J).

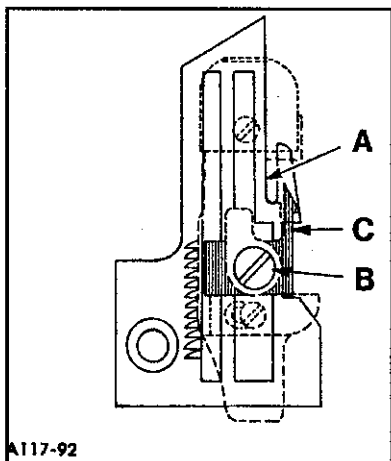

Fig. 18

### PRESSER FOOT PRESSURE

Sufficient pressure must be maintained to feed work uniformly. Excessive spring pressure will cause the feed dogs and presser foot to wear prematurely when chaining. If it is desirable to increase or decrease the amount of presser foot pressure position, presser arm in sewing position and lock in place. Loosen nut (L, Fig. 17) and turn adjusting screw (M) clockwise to increase pressure or counterclockwise to decrease pressure. Tighten nut (L) loosen cap nut (N) and position nut (P) so there is a  $1/16$ " (1.6mm) clearance between adjusting screw (M) and nut (P). Hold nut (P) in position and tighten cap nut (N).



## SETTING THE STITCH LENGTH

Stitch length is determined by the combination of feed eccentrics used. The outer (left) eccentric (A, Fig. 19) actuates the main (rear) feed dog. The inner (right) eccentric (B) actuates the differential (front) feed dog.

To change the feed eccentrics, remove nut (C) and washer (D) from end of shaft (E). Turn handwheel in operating direction until key slot in eccentric is toward front. Using hooked eccentric extractor (F), supplied with machine, reach behind eccentrics as shown and withdraw eccentrics. It may be necessary to move handwheel back and forth slightly during extraction. If eccentrics are unusually tight fitting, it may be necessary to remove nut (G) and feed driving connection (H). Continue as originally suggested.

When assembling feed eccentrics, make sure the hubs are facing each other. Be careful not to damage the shaft or the key. Tighten nuts (C and G); then torque nut (G) to 19-21 in. lbs. (2.1 - 2.4Nm).

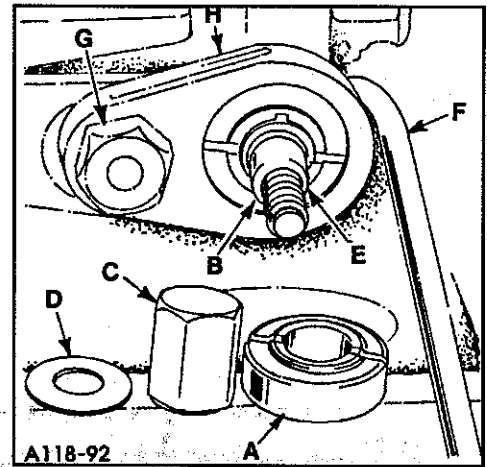

## STARTING TO OPERATE (503 AND 504 STITCH)

Be sure machine is threaded according to threading diagram Fig. 2 for the 503 stitch or according to Fig. 1 for the 504 stitch. With thread tensions light, set looper thread eyelet (E, Fig. 2) or looper thread eyelets (C and E, Fig. 1) approximately horizontal and in the middle of their front to back locations. Operate machine slowly, without presser foot in place, to make sure chain forms and moves off stitch tongue freely. Swing presser foot into position, insert material and sew slowly.

## NEEDLE THREAD CONTROL (503 AND 504 STITCH)

While sewing on material, check needle thread control as follows: Usually all needle thread is drawn on needle down stroke. At top of needle stroke, thread should be just tight enough to feed chain off stitch tongue. Stitch tends to pull down slightly if excessive thread is pulled on the up stroke. With needle at bottom of stroke, position needle thread eyelet (P, Fig. 1) so that needle thread cam pull off (R) just contacts needle thread.

It is desirable to adjust the needle thread eyelet well-forward (toward the operator) to delay slightly, the tightening of the needle thread.

## LOWER LOOPER THREAD CONTROL (503 STITCH)

With material under presser foot, set lower looper thread eyelet (E, Fig. 2) back and down far enough so thread is a little slack when spreader reaches its extreme left position. Lower looper thread eyelet (E) should be about horizontal.

Frame looper thread guide (G) should be set with its eyelet approximately 1/8" (3.17mm) to the right of heel eyelet of looper (J) at the time lower looper is at extreme left end of its travel.

## LOWER LOOPER THREAD CONTROL (504 STITCH)

With material under presser foot, set lower looper thread eyelet (E, Fig. 1) back far enough so thread is a little slack when looper thread pull-off (S) reaches its most rearward position. Looper thread pull-off (S) is set about 1/32" (.79mm) distance behind needle thread cam pull-off (R). Frame looper thread guide (G) should be set with its eyelet approximately 1/8" (3.17mm) to the right of lower looper (J) heel eyelet at the time lower looper is at extreme left end of its travel.

## **LOWER LOOPER THREAD CONTROL (504 STITCH) (CONT.)**

While sewing on material, check drawing off of looper thread as follows:

A portion of lower looper thread should be drawn through the tension before lower looper thread comes off upper looper. To increase amount of thread drawn through the tension while lower looper thread is on upper looper, move lower looper thread eyelet (E) back, keeping the same amount of pull-off action.

## **UPPER LOOPER THREAD CONTROL (504 STITCH)**

Before proceeding to adjust upper looper thread eyelet (C Fig. 1) balance all three tensions to give a normal appearing stitch. Moderate change in these tensions will not markedly affect the purl.

During needle down stroke, forward stroke of looper thread pull-off (S) will draw upper looper thread through the tension. When normal amount of looper thread is drawn, upper looper thread will have almost all slack taken up as looper thread pull-off reaches its most rearward position.

## **POSITIONING THE PURL (504 STITCH)**

To move the purl more under the edge, both looper thread eyelets (C and E, Fig. 1) should be moved forward or backward keeping the same amount of pull-off. Usually it is better to have slightly more pull-off on upper thread than on lower thread.

If it becomes necessary to move looper thread pull-off (S), be sure to take up all end play in needle drive shaft before tightening. If upper looper is located so that it is higher over the throat plate than recommended on Table V, the purl will tend to form near top edge. If upper looper is too low, the purl will form nearer to the bottom edge.

## **THREAD TENSIONS (503 STITCH)**

Balance both tensions to give a normal appearing stitch. Moderate change in these tensions will not markedly affect the purl.

## **THREAD TENSIONS (504 STITCH)**

The needle thread tension required is a function of needle thread and material being sewn. In general, lower looper thread tension should be set as high as possible without causing needle thread to be pulled down. Upper looper thread tension should be increased as long as the elasticity of the chain increases, or until the purl is pulled too far over the top.

## **STARTING TO OPERATE (505 STITCH)**

Be sure machine is threaded according to threading diagram (Fig. 1, 2, or 3).

With thread tensions light, set upper and lower looper thread eyelets (C and E) about horizontal and in the middle of their front to back locations.

Operate machine slowly, without presser foot in place, to make sure that chain forms and moves off the tongue freely.

Swing presser foot into position, insert materials, and sew slowly.

## **NEEDLE THREAD CONTROL (505 STITCH)**

While sewing on material, check needle thread control as follows: About 60% of needle thread required for the stitch should be drawn on needle downstroke.

To increase thread drawn on downstroke, position needle thread eyelet (P, Fig. 1, 2, or 3) farther to the rear.

## LOWER LOOPER THREAD CONTROL (505 STITCH)

Set lower looper thread eyelet (E, Fig. 1, 2, or 3) about horizontal and all the way forward in its slot. Frame looper thread guide (G) should be set with its eyelet approximately 1/8" (3.17mm) to the right of lower looper (J) heel eyelet, when lower looper is at the left end of its stroke.

## UPPER LOOPER THREAD CONTROL (505 STITCH)

With material under presser foot, set upper looper thread eyelet (C, Fig. 1, 2, or 3) to rest on top of lower looper thread eyelet (E), and back far enough so upper looper thread is a little slack when upper looper reaches the left end of its stroke.

## POSITIONING THE SQUARE EDGE (505 STITCH)

Position of lower looper thread at the edge is located by balancing needle and upper looper thread tensions.

To reduce amount of lower looper thread in the stitch, or close the edge more, increase lower looper thread tension.

## POWER AIR-KLIPP® CHAIN CUTTER ADJUSTMENTS

### SETTING KNIFE CROSS OVER

The knife cross over is set at the factory, however, adjustment will be necessary after replacing or repairing knives. With sewing motor switch in "OFF" position and air line connected to air motor for "AIR-KLIPP" chain cutter (see setting pressure valve) depress treadle until air motor begins to operate, in and out. With forefinger, carefully press against the moving drive link (A, Fig. 20) until air motor stops.

With treadle still depressed, check the knife cross over. The cross over of the lower knife to the upper knife is positioned correctly, when the lower knife is 2/3 from the front of the upper knife as shown in Fig. 20. If adjustment is required, loosen screws (B), reposition air motor (C) slightly to the left if lower knife is positioned to far left or slightly to the right if lower knife is positioned too far right. Retighten screws (B) and recheck cross over.

**CAUTION!** Check to ensure that lower knife does not strike against inside of "AIR-KLIPP" chain cutter tube. A slight clearance must be provided at point (D).

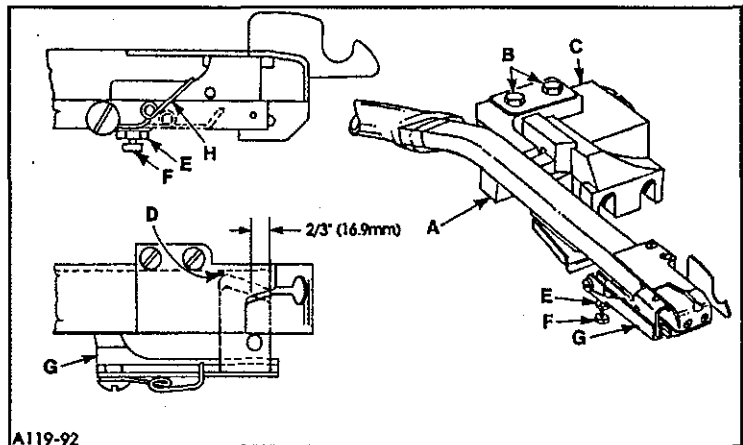

Fig. 20

### SETTING KNIFE CUTTING

If adjustment is required, loosen nut (E, FIG. 20) and turn lower knife adjusting screw (F) clockwise (a small amount at a time) while manually operating knife lever (G), continuously checking with a piece of thread to see if knives are cutting. As soon as the knives fail to cut the thread and the shear angle is zero, turn screw (F) counterclockwise approximately 1/4 turn and lock with nut (E). Check cutting action of knives with sewing motor switch "ON".

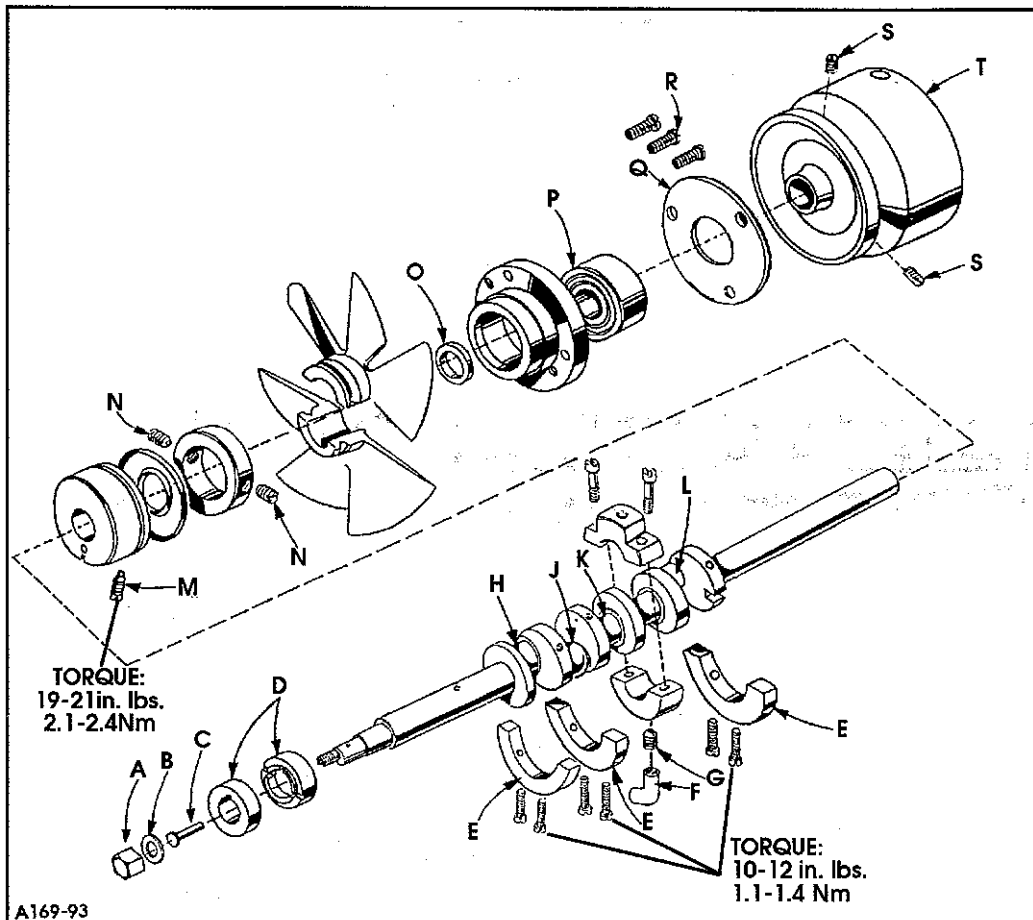

Fig. 21

### SETTING KNIFE PRESSURE

Torsion spring (H, FIG. 20) initially should be horizontal in its free state and then lifted over the knife. More pressure can be obtained by bending spring (H) slightly to the left (away from lower knife); less pressure - by bending spring slightly to the right (towards lower knife).

### SETTING PRESSURE VALVES

Regulate valve on pneumatic control device for air motor of the "AIR-KLIPP" chain cutter to approximately 20-22 psi (1.5 bar) when air motor is operating. Regulate valve on pneumatic control device for the suction air to obtain maximum suction, yet so that the FABRIC TO BE SEWN will not be cut by the "AIR-KLIPP" chain cutter knives.

### REMOVING THE CRANKSHAFT

The crankshaft can be withdrawn easier if these steps are followed:

1. Drain oil by removing plug screw located on back of machine near bottom edge of base.
2. Remove top and bottom covers of machine.
3. Remove feed eccentric nut (A, Fig. 21) and washer (B) and metering pin (C). With the aid of the eccentric extractor, slip off eccentrics (D).
4. Remove three counterweights (E). Identify these counterweights so that they will be reassembled in their proper positions.

## REMOVING THE CRANKSHAFT (CONT.)

5. Remove caps of bearings on crankshaft at points H, J, and L. When reassembling bearing caps make sure they are in their original position. Trade marks are stamped on both halves of the caps and both trade marks should be on the same side of the bearings. Also, screws should be reassembled in the same holes from which they were removed.

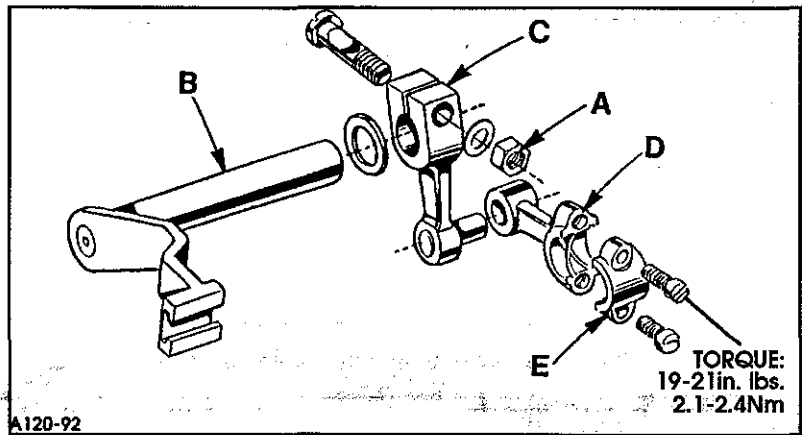

Fig. 22

6. Loosen clamp nut (A, Fig. 22) which holds upper knife driving arm (B). Access clamp nut (A) through the top cover. Draw driving arm (B) to the left until upper knife driving lever (C) and connecting rod (D) drop, allowing removal of bearing cap (E). This is at bearing point (K, Fig. 21) on crankshaft. Observe the same precautions when reassembling cap as described in Step 6.
7. Remove oil return tube (F, Fig. 21) located on the bottom of the bed casting. Loosen set screw (G) which holds inner right crankshaft bearing, located on the bottom of the bed casting beyond the oil return tube.
8. Loosen screws (M) & (N) in the fan collar and remove both halves of the cooling fan.
9. Loosen screws (S) remove pulley (T).
10. Remove screws (R) and take off bearing retaining plate (Q). Bearing (P) may be removed at this time.
13. The crankshaft may now be removed.
14. If necessary to replace ball bearing (P), it should be pressed off of the shaft on an arbor press. In replacing the bearing it must be pressed on carefully until it seats against ground thrust washer (O), or use Union Special pulling tool numbers 4196301 and 4196303 for removal and replacement.
15. Carefully reversing the above steps should simplify reassembly of the crankshaft. Checking exploded view drawings for location of various parts and constant testing for binds during reassembly will also prove helpful.
16. Before reassembling thoroughly clean and dry top and bottom covers and gaskets. Before reassembling bottom cover make sure that the spring pressed oil wick which lubricates left crankshaft bearing is inserted in hole in casting and that it contacts shaft. The wick stands vertically on its spring against bottom cover. Coat the oil drain plug with a sealing compound before reassembling to prevent oil leakage. No. 1 Crane Lead Seal is recommended.

**NOTE:** Seal 39593J elbow with pipe sealant (CE58). Make sure NO sealant gets in the oil hole. Tighten elbow finger tight, then back off so the oil line will run along the back of the machine.





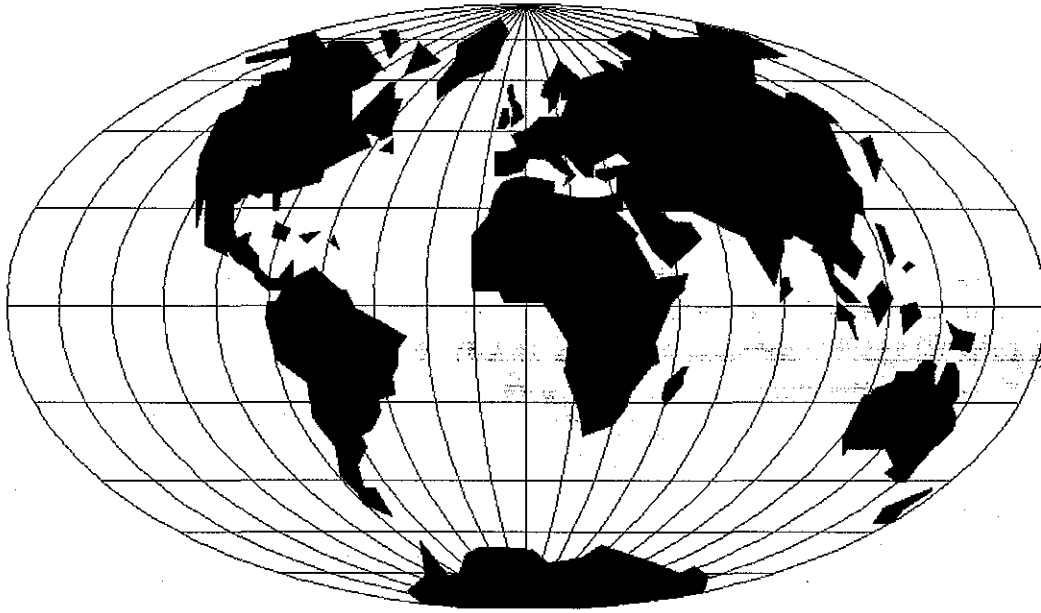

## WORLDWIDE SALES AND SERVICE

Union Special Corporation maintains sales and service facilities throughout the world. These offices will aid you in the selection of the right sewing equipment for your particular operation. Union Special Corporation representatives and service technicians are factory trained and are able to serve your needs promptly and efficiently. Whatever your location, there is a qualified representative to serve you.

It is important to remember that LEWIS® machines are also products of Union Special Corporation, thus offering the Finest Quality sewing machines.

---

Corporate Offices:      One Union Special Plaza  
   Huntley, IL 60142  
   (708) 669-5101

Brussels, Belgium  
Commerce, CA  
Leicester, England  
Miami, FL  
Paris, France  
Norcross, GA  
Möglingen, Germany  
Huntley, IL  
Milan, Italy  
Osaka, Japan  
Hong Kong  
Charlotte, N.C.  
Warminster, PA  
Montreal, Quebec  
El Paso, TX  
Mission, TX

Other Representatives throughout all parts  
of the world.



*Union Special*  
INDUSTRIAL SEWING EQUIPMENT