



Union Special
INDUSTRIAL SEWING EQUIPMENT

**STYLES ADJUSTING INSTRUCTIONS AND
ILLUSTRATED PARTS LIST**

39500FS

39500FT

39500FU

**39500GD HIGH STYLED HIGH SPEED OVERSEAMERS
WITH INTERMITTENT DIFFERENTIAL FEED**

39500GL

39500GT

39500JP

**CATALOG
NO. 103FS**

**FIRST
EDITION**

FIRST EDITION
© 1967

PRINTED 1996 IN USA

INFORMATION SUBJECT TO CHANGE WITHOUT NOTICE

© UNION SPECIAL CORPORATION ALL RIGHTS RESERVED IN ALL COUNTRIES.

IDENTIFICATION OF MACHINES

Each Union Special machine is identified by a Style number on a name plate on the machine. Style numbers are classified as standard and special. Standard Style numbers have one or more letters suffixed, but never contain the letter "Z". Example: "Style 39500 FS". Special Style numbers contain the letter "Z". When only minor changes are made in a standard machine, a "Z" is suffixed to the standard Style number. Example: "Style 39500 FSZ".

Styles of machines similar in construction are grouped under a Class number which differs from the Style number in that it contains no letters. Example: "Class 39500".

APPLICATION OF CATALOG

This catalog applies specifically to the standard Styles of machines as listed herein. It can also be applied with discretion to some Special Styles of machines in Class 39500. References to directions, such as right, left, front, back, etc., are given from the operator's position while seated at the machine. Operating direction of handwheel is away from operator.

STYLES OF MACHINES

Hi-Style High Speed, One or Two Curved Blade Needles, Two Looper, Three or Four Thread Overseaming Machine. Intermittent Differential Feed, Trimming Mechanism with Spring Pressed Lower Knife, Automatic Lubricating System.

39500 FS Single needle three thread, medium to heavy duty machine, for seaming and intermittently gathering or shirring on woven and knit materials such as dresses, aprons, lingerie, smocks, nightgowns and similar garments. Knee press controlled tandem intermittent differential feed. Slotted presser foot to separate top and bottom plies. Gathering ratio up to 3 to 1 depending on stitch length. Seam specification 504-SSa-1. Standard width of seam 1/8 inch. Stitch range 8-20 per inch. Cam adjusted main and differential feeds. Maximum recommended speed 6000 R. P. M.

39500 FT Single needle three thread, medium to heavy duty machine, for seaming and intermittently gathering or shirring on woven and knit materials such as dresses, aprons, lingerie, smocks, nightgowns and similar garments. Knee press controlled tandem intermittent differential feed. Independent swing-out pressure plate attachment for shirring. Gathering ratio up to 3 to 1 depending on stitch length. Seam specification 504-SSa-1. Standard width of seam 3/16 inch. Stitch range 8-20 per inch. Cam adjusted main and differential feeds. Maximum recommended speed 6000 R. P. M.

39500 FU Single needle three thread, medium to heavy duty machine, for seaming and intermittently gathering or shirring on woven and knit materials such as dresses, aprons, lingerie, smocks, nightgowns and similar garments. Knee press controlled tandem intermittent differential feed. Presser foot bottom grooved for 1/8 inch cord. Independent swing-out pressure plate attachment for shirring. Gathering ratio up to 5 to 1 depending on stitch length. Seam specification 504-SSa-1. Standard width of seam 3/16 inch. Stitch range 8-20 per inch. Cam adjusted main and differential feeds. Maximum recommended speed 5500 R. P. M.

39500 GD Two needle four thread, medium to heavy duty machine, for seaming and intermittently gathering or shirring on woven and knit materials such as dresses, aprons, lingerie, smocks, nightgowns and similar garments. Knee press controlled tandem intermittent differential feed. Independent swing-out pressure

STYLES OF MACHINES (Continued)

plate attachment for shirring. Gathering ratio up to 3 to 1 depending on stitch length. Seam specification 512-SSa-1. Standard width of seam from left needle 17/64 inch. Stitch range 8-20 per inch. Cam adjusted main and differential feeds. Maximum recommended speed 6000 R. P. M.

39500 GL Two needle four thread, medium to heavy duty machine, for seaming and intermittently gathering or shirring on woven and knit materials such as dresses, aprons, lingerie, smocks, nightgowns and similar garments. Knee press controlled tandem intermittent differential feed. Independent swing-out pressure plate attachment for shirring. Gathering ratio up to 5 to 1 depending on stitch length. Seam specification 512-SSa-1. Standard width of seam from left needle 17/64 inch. Stitch range 8-20 per inch. Cam adjusted main and differential feeds. Maximum recommended speed 5500 R. P. M.

39500 GT Single needle three thread, medium to heavy duty machine, for seaming and intermittently gathering or shirring on all types of cotton, dacron, rayon and silk fabrics where a 3/32 inch turned down hem is desired. Knee press controlled tandem intermittent differential feed. Presser foot has a short curler stitch tongue. Independent swing-out pressure plate attachment for shirring. Gathering ratio up to 3 to 1 depending on stitch length. Seam specification 504-EFe-1 inverted. Standard width of seam 3/32 inch. Stitch range 10-20 per inch. Cam adjusted main and differential feeds. Maximum recommended speed 6000 R. P. M.

39500 JP Single needle three thread, light to medium duty machine, with operator adjusted intermittent differential feed for seaming and trimming all types and weights of flat, warp and ribbed knit cotton, wool, rayon and silk fabrics where long straight seams are necessary. Thumbscrew feed which allows either reversed or forward differential feeding. Seam specification 504-SSa-1. Standard width of seams 3/32 and 1/8 inch. Stitch range 8-30 per inch. Cam adjusted main and differential feeds. Maximum recommended speed 6000 R. P. M.

OILING

CAUTION! Oil was drained from machine when shipped, so reservoir must be filled before beginning to operate. Oil capacity of Class 39500 is six ounces. A straight mineral oil of a Saybolt viscosity of 200 to 250 seconds at 100° Fahrenheit should be used.

Machine is filled with oil at spring cap in top cover. Oil level is checked at sight gauge on front of machine. Red bulb on oil level indicator should show between gauge lines when machine is stationary.

Machine is automatically lubricated. No oiling is necessary, other than keeping main reservoir filled. Check oil daily before the morning start; add oil as required.

The oil drain plug screw is located at back of machine near bottom edge of base. It is a magnetic screw designed to accumulate possible foreign materials which may have entered the crank case. It should be removed and cleaned periodically.

NEEDLES

Each Union Special needle has both type and size number. The type number denotes the kind of shank, point, length, groove, finish and other details. The size number, stamped on the needle shank, denotes largest diameter of blade, measured in thousandths of an inch, midway between shank and eye. Collectively, type and size number represent the complete symbol which is given on the label of all needles packaged and sold by Union Special.

Class 39500 machines use a curved blade needle. The standard recommended needle for Styles 39500 FS, FT, FU, GD, GL and JP is Type 154 GAS, while the standard needle for Style 39500 GT is Type 154 GBS. Below are the type numbers, description and sizes available of the recommended needles.

NEEDLES (Continued)

<u>Type No.</u>	<u>Description and Sizes</u>
154 GAS	Round shank, round point, curved blade, standard length, single groove, struck groove, spotted, chromium plated and is available in sizes 022, 025, 027, 029, 032, 036, 040, 044, 049, 054.
154 GBS	Round shank, round point, curved blade, standard length, double groove, struck groove, spotted, chromium plated and is available in sizes 025, 027, 029, 032.

To have needle orders promptly and accurately filled, an empty package, a sample needle, or the type and size number should be forwarded. Use description on label. A complete order would read: "1000 Needles, Type 154 GAS, Size 027".

Selection of proper needle size is determined by size of thread used. Thread should pass freely through needle eye in order to produce a good stitch formation.

Success in the operation of Union Special machines can be secured only by use of needles packaged under our brand name, *Union Special*, which is backed by a reputation for producing highest quality needles in materials and workmanship for more than three-quarters of a century.

CHANGING NEEDLES

Release pressure on presser foot by turning presser foot release bushing (AG, Fig. 1 and 1A) and swing presser arm (U) out of position. Turn handwheel in operating direction until needle is at its lowest point of travel. Using hexagonal socket wrench No. 21388 AU, furnished with machine, loosen needle clamp nut about 1/4 turn. Again turn handwheel until needle is at high position; withdraw needle.

To replace needle, leave needle holder at high position and, with the flat to the left, insert needle in holder until it rests against stop pin. Keeping needle in this position, turn handwheel until holder is again at its low point of travel; then tighten nut. Return presser arm (U) to position; re-lock presser foot release bushing (AG).

THREAD STAND (504 STITCH)

After thread comes from cones on cone support (A, Fig. 1), it is brought up through back hole of thread eyelet (B), then down through the front hole of thread eyelet. Next it is threaded through the upper holes of tension thread guide (C) from front to back and then through the lower holes from back to front. It should be noted that the lower looper thread is threaded through the tension thread guide (C), first through the upper hole back to front, second through the middle hole front to back and third through the lower hole back to front. All threads then continue between the tension discs (J), through tension post slot (K) in tension post (G) and on through front thread guide (M).

THREAD STAND (512 STITCH)

After thread comes from cones on cone support (A, Fig. 1A), the needle threads are threaded through the back bar of the thread eyelet (B), under the middle bar and through the center holes of the front bar. The looper threads come from the cones, through holes of the middle bar from back to front and then through the two outside holes of the front bar. Next it is threaded through the upper holes of tension thread guide (C) front to back and then through the lower holes from back to front. The threads continue between the tension discs (J), through tension post slot (K) in tension post (G) and on through front thread guide (M).

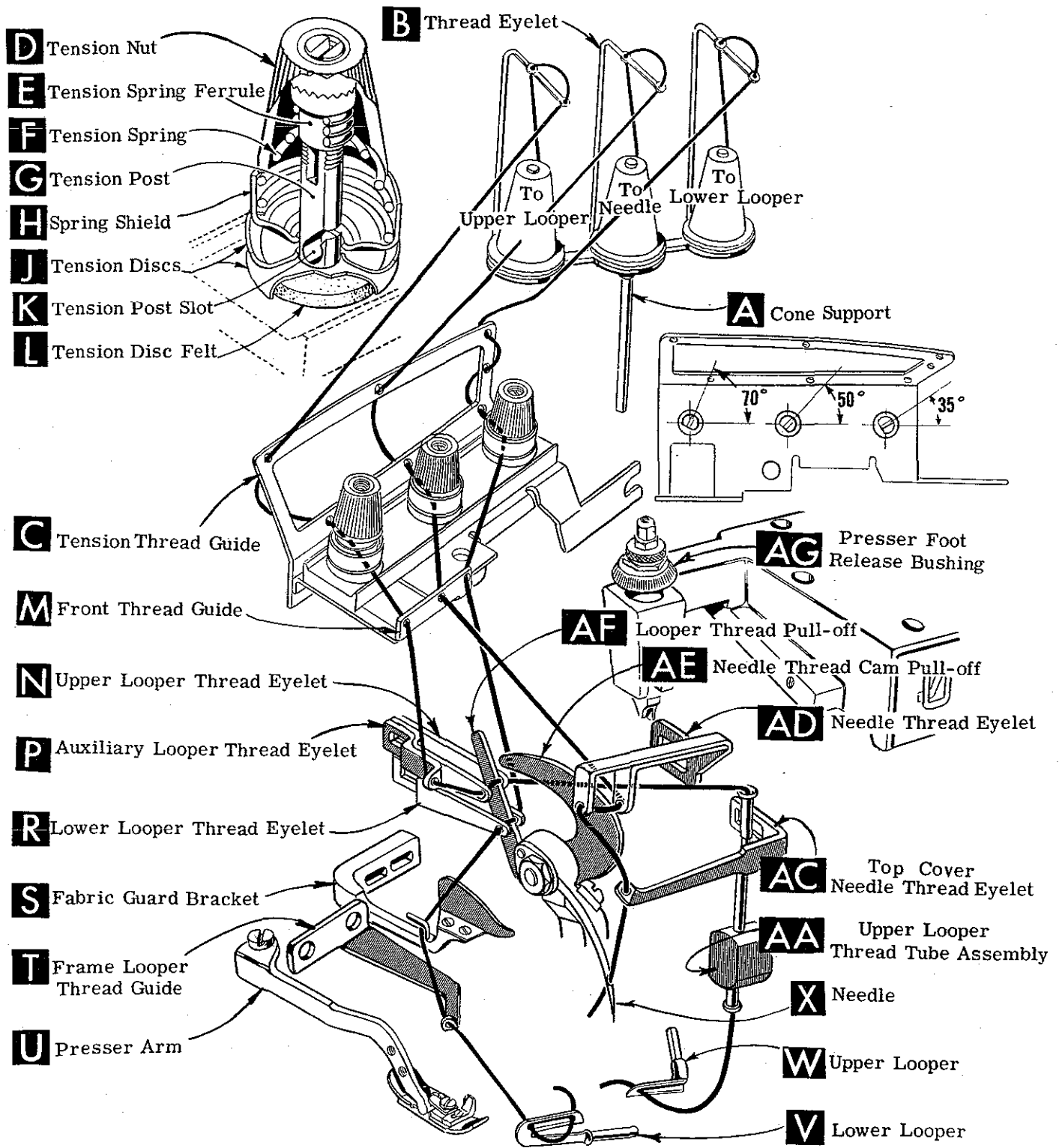

Fig. 1

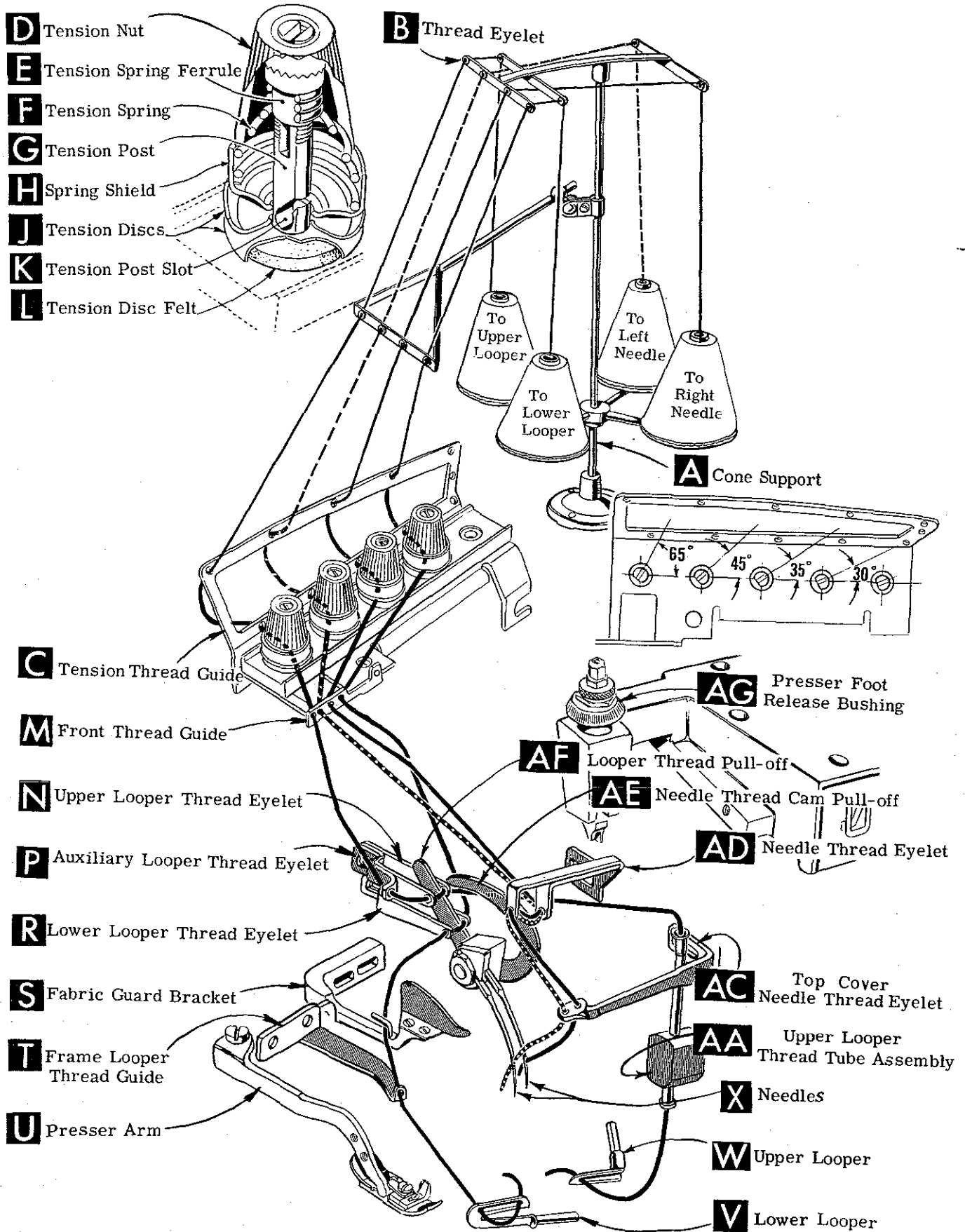

Fig. 1A

THREAD STAND (512 STITCH) (Continued)

NOTE: Refer to Fig. 1 for threading Styles 39500 FS, FT, FU, GT and JP, or refer to Fig. 1A for threading Styles 39500 GD and GL.

THREADING

Only parts involved in threading are shown in threading diagrams (Fig. 1 and 1A). Parts are placed in their relative positions for clarity.

It will simplify the threading of these machines to follow the recommended sequence of threading lower looper first, upper looper second, and needle or needles third.

The threading in Fig. 1 and Fig. 1A are the same, the only difference will be the threading of two needle threads in Fig. 1A as compared to one needle thread in Fig. 1. The additional needle in Fig. 1A moves the lower looper thread tension post to the right.

Before beginning to thread, swing cloth plate open, turn handwheel in operating direction until needle (X) is in high position, release pressure on presser foot by turning presser foot release bushing (AG), and swing presser arm (U) out of position.

Be sure the threads, as they come from the tension thread guide (C), are between the tension discs (J) and in tension post slot (K) in tension post (G). The tension posts should be positioned so the tension post slot will be at the approximate angle for the different threads as indicated in Fig. 1 and 1A.

TO THREAD LOWER LOOPER

Double end of thread and lead it through both eyes of lower looper thread eyelet (R, Fig. 1 or 1A) from right to left. NOTE: Thread must pass in front of looper thread pull-off (AF). Lead thread behind fabric guard (S) and through hole of frame looper thread guide (T). Turn handwheel in operating direction until heel of lower looper (V) is all the way to the left; then thread through both eyes from left to right. Left eye of lower looper can be threaded easily if tweezers are in left hand.

TO THREAD UPPER LOOPER

Turn handwheel until point of upper looper (W) is all the way left. Lead thread through auxiliary looper thread eyelet (P) from back to front, then through both eyes of upper looper thread eyelet (N) from left to right. NOTE: Thread must pass in front of looper thread pull-off (AF). After pulling up upper looper thread tube assembly (AA), lead thread under neck of top cover casting and down through thread tube assembly (AA). Pull thread out bottom of tube; push tube down, then insert thread through upper looper eye from front to back.

CAUTION! Be sure upper looper thread is under lower looper thread when passing from tube assembly to upper looper eye.

TO THREAD THE NEEDLE

Turn handwheel in operating direction until needle (X, Fig. 1 or 1A) is at its highest position. Insert needle thread or threads from right to left, through both eyes of needle thread eyelet (AD), under neck of top cover casting; and then down through hole or holes in top cover needle thread eyelet (AC). Thread needle from front.

THREAD TENSION

The amount of tension on needle and looper threads is regulated by tension nuts (D, Fig. 1 or 1A). Tension on threads should be only enough to secure proper stitch formation.

PRESSER FOOT PRESSURE

Sufficient presser foot pressure to feed work uniformly should be maintained. Should it be necessary to increase or decrease amount of pressure on presser foot, loosen lock nut (A, Fig. 2) and turn adjusting screw (B). Adjusting screw has a right hand thread so tightening increases pressure, loosening decreases pressure. When pressure adjusting screw (B) has been properly set, tighten lock nut (A). With presser foot resting on throat plate, position locking nut (C) so that its under surface is approximately 1/32 inch to 1/16 inch from the top surface of adjusting screw (B). Set cap (D) against locking nut (C).

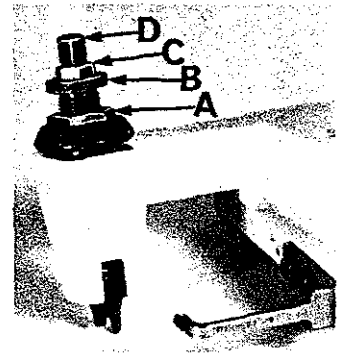

Fig. 2

FEED ECCENTRICS

Feed eccentrics used in Style 39500 FS machines have been selected to produce approximately 14 stitches per inch. It will be noted that the part number of main feed eccentric is No. 39540 B-14 while that of the differential feed eccentric is No. 39540 B-4. Minor numbers of the part symbol indicate approximately the number of stitches obtainable when using that eccentric. Unless otherwise specified, machine will be shipped with above combination of eccentrics. Refer to exploded views for eccentrics used on the other styles of machines covered in this catalog.

Generally speaking, the main (right hand) feed eccentric determines the number of stitches produced; the differential (left hand) feed eccentric is selected so as to give the proper differential or gathering action.

Following stitch number feed eccentrics are available under No. 39540 B-4, 5, 6, 7, 8, 9, 10, 11, 12, 13, 14, 15, 16, 18, 20, 22, 24, 26, 28, 30, 32, 34, 36, 40. Only two eccentrics are supplied with each machine. Additional eccentrics may be ordered separately. To order an eccentric, use No. 39540 B with a minor number suffixed to indicate number of stitches desired. Example: "39540 B-14".

ASSEMBLING AND ADJUSTING SEWING PARTS

Before assembling and adjusting sewing parts, remove cloth plate, fabric guard, chip guard, upper knife assembly, lower knife holder assembly, then follow this suggested sequence:

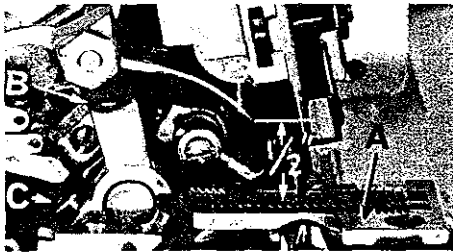

Fig. 3

SETTING THE NEEDLE

With throat plate assembled in position, needle should center in the front end of needle slot. When needle is at high position, needle point should be set 1/2 inch above throat plate (A, Fig. 3) for styles 39500 FS, FT, FU, GT, and JP; 15/32 inch for Styles 39500 GD and GL. To align needle or set the height above the throat plate, move needle driving arm (B, Fig. 3) by loosening clamp screw (C). After needle has been set properly, tighten clamp screw and remove throat plate.

SETTING THE NEEDLE (Continued)

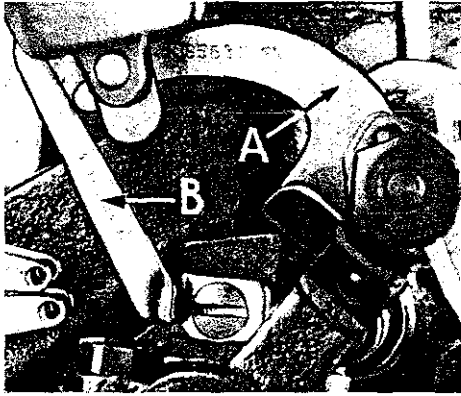

Fig. 4

If needle thread cam pull-off (A, Fig. 4) overlaps looper thread pull-off (B), separate by moving looper thread pull-off back. When retightening looper pull-off screw, be sure to take up end play in needle driving arm.

At this point, insert lower looper (A, Fig. 5) into bar (B). With lower looper at left end of its stroke, set looper point $1/8$ inch from center of needle (Fig. 5), using looper gauge No. 21225- $1/8$, on Styles 39500 FS, FT, FU, GT and JP. On Styles 39500 GD and GL, with lower looper at left end of its stroke, set looper point $1/16$ inch from center of left needle, using looper gauge No. 21225- $1/16$. Now assemble differential (front) feed dog.

SETTING THE REAR NEEDLE GUARD

Set rear needle guard (A, Fig. 6) as high as possible, without interfering with either lower looper or movement of lower knife holder, but still in position to deflect needle or needles forward .002-.004 inch. Screw (B) is used to set rear needle guard. Make sure there is no interference between rear needle guard and lower looper.

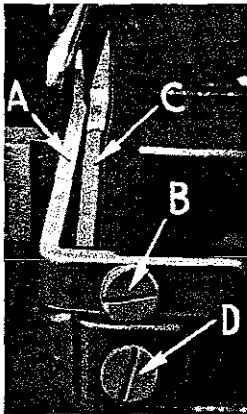

Fig. 6

there is no interference between needle guards and differential feed dog.

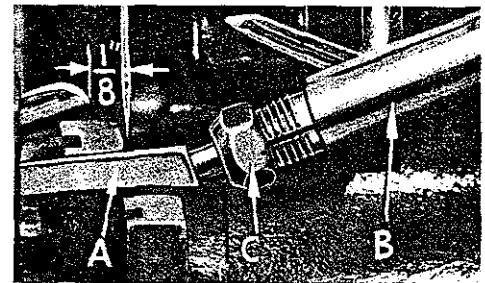

Fig. 5

SETTING THE LOWER LOOPER

Now finish lower looper adjustment. As lower looper moves to the right, its point should be set into the needle scarf (A, Fig. 7) until the needle springs forward from rear guard surface another .002-.004 inch. Tighten nut (C, Fig. 5) securely.

SETTING THE FRONT NEEDLE GUARD

Assemble front needle guard (C, Fig. 6). When lower looper is springing needle off back guard, set front needle guard as close as possible to needle without touching. Screw (D) is used to adjust and set front needle guard. After this setting make sure

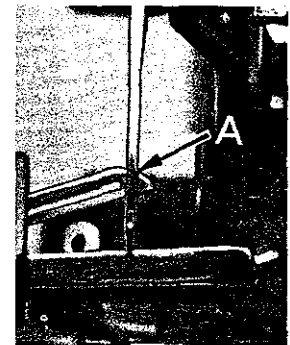

Fig. 7

SETTING THE UPPER LOOPER

Insert upper looper (A, Fig. 8) in its holder. Screw (B), holds upper looper in its holder, and permits it to be pushed in or out of turned around its shank. Insert upper looper holder into upper looper shaft, if it is not already in place. Screw (C), on clamp holds the upper looper holder in the shaft. Locate upper looper in its holder so that the shank extends $1/16$ to $3/32$ inch beyond holder (Fig. 8), FS, FT, FU, GD, GL, GT, and JP.

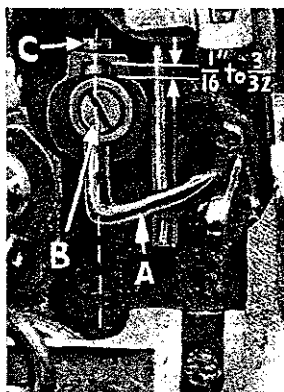

Fig. 8

When the upper looper is at the right end of its stroke, upper looper holder should be set to position upper looper shank approximately vertical on Styles 39500 FS, FT, FU, and GT (Fig. 8).

SETTING THE UPPER LOOPER (Continued)

NOTE: On Styles 39500 GD, GL and JP the upper looper holder should be set to position upper looper shank back of vertical, when the upper looper is at right end of its stroke. Be sure, on all styles, there is a clearance between heel of looper and casting. By adjusting looper holder in or out of upper looper shaft and by turning the looper around its shank, set upper looper point to cross lower looper to the left of the lower looper eye with 0.002 to 0.004 clearance (Fig. 9).



Fig. 9

As the upper looper moves toward the top of its stroke, the heel of the upper looper should pass behind the lower looper head with $1/64$ to $1/32$ inch clearance.

Next, turn handwheel until looper is at the left end of its travel; check dimensions of upper looper point with respect to needle and throat plate (Fig. 10). If resetting is necessary, do it by moving the upper looper holder (A, Fig. 10). Figure 10 represents the dimensional setting for Styles 39500 FS, FT, FU, and GT.

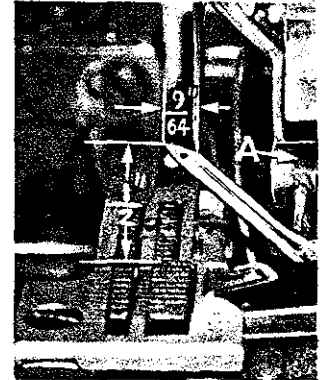

Fig. 10

NOTE: For Style 39500 JP, the settings are $5/32$ and $31/64$ inch. For Styles 39500 GD and GL, the settings are $1/8$ inch to the right needle and $17/32$ inch. For example dimension $1/2$ inch is increased by turning upper looper holder counterclockwise looking from left end of machine; dimension $9/64$ inch is increased by pulling upper looper holder to the left, out of upper looper shaft. After these changes are made, it may be necessary to turn upper looper around its shank slightly to maintain the condition shown in Fig. 9.

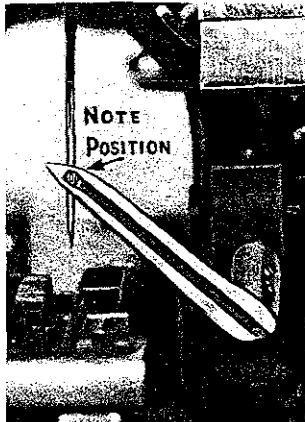

Fig. 11

When the correct setting is obtained, it can be checked quickly as follows: As upper looper is moving to the right, when upper looper eye centers on the needle, the eyes of the upper looper and needle should align exactly (Fig. 11).

Check setting to avoid interference between upper looper and needle on needle downstroke. If needle rubs the back of upper looper, pull looper out of its holder slightly and rotate looper a short distance counterclockwise, looking from left end of machine. Reset to maintain dimensions of Fig. 9, 10, 11.

SETTING THE FEED DOGS

Now assemble differential feed dog (A, Fig. 12) if not already on machine. Assemble main feed dog (B) and set both feeds so the top surfaces of the teeth all lie in the same plane. This can be checked by sighting across the teeth with a straight edge. Now assemble throat plate. Feed dogs should now be leveled with throat plate surface by rotating feed tilting adjusting pin (C). This pin raises or lowers the back end of both feed bars at the same time.

The feed dogs should be set level at the time teeth first appear above the throat plate. Screw (E) locks feed tilting adjusting pin in place. Now set feed dogs so that teeth rise about $3/64$ inch above throat plate. The differential feed may be set slightly higher if desired.

SETTING THE FEED DOGS (Continued)

NOTE: On Style 39500 JP, set the chaining feed dog level with the top of throat plate when feed is at the top of its travel.

SETTING THE LOWER KNIFE

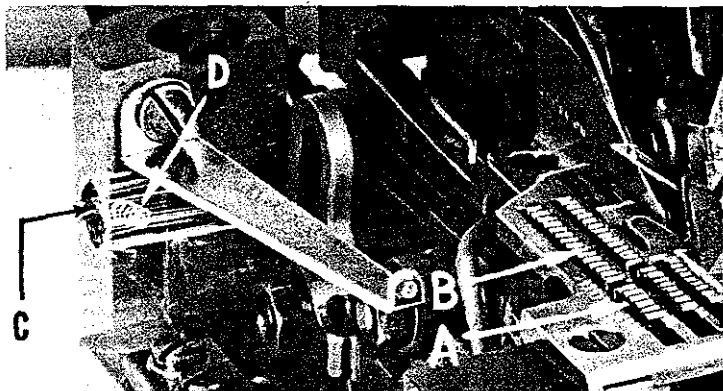

Fig. 12

Lower knife may be secured in any position by tightening screw (B) and locking nut (C) against support bracket. Because screw (B) also serves as latch pin for the cloth plate latch spring, it should always be locked with nut (C) even when screw is not tightened against lower knife holder.

Replace lower knife holder assembly. Lower knife (A, Fig. 13) should be set with cutting edge flush with throat plate surface. Adjustments are made with hexagonal head screw which holds lower knife. Lower knife is spring pressed against upper knife, so no lateral adjustment is necessary when width of trim is changed.

SETTING THE UPPER KNIFE

Replace upper knife assembly. Clamp upper knife (D, Fig. 13) in position, setting nut (E) to hold clamp (F) in its most clockwise position against upper knife. Upper knife chain guard (G) should be positioned so that the guarding section is approximately 1/64 inch behind the cutting edge and in contact with the top surface of the upper knife.

At the bottom of its stroke, front cutting edge of upper knife should extend not less than 1/64 inch below cutting edge of lower knife.

After upper knife has been set for proper width of trim, screw (H) must be tightened to lock the upper knife holding block (J) in place. This will simplify re-setting when upper knife is replaced.

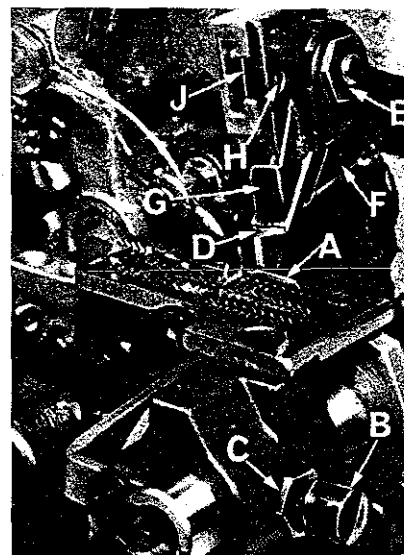

Fig. 13

SETTING THE STITCH LENGTH

Length of stitch is determined by the combination of feed eccentrics used. Outer (left) eccentric (A, Fig. 14) actuates differential (front) feed dog; while the inner (right) eccentric (B) actuates the main (rear) feed dog.

In assembling feed eccentrics, be sure hubs are facing each other. Be careful not to damage shaft or key. Use nut (C) and washer (D) and tighten securely.

To change feed eccentric, remove thrust finger (L) from its seat on the main frame (M). Remove nut (C) and washer (D) from end of shaft (G). Remove nut (H) from stud (J). Link (K) and eccentric (A) will now slip off.

SETTING THE STITCH LENGTH (Continued)

Using hooked eccentric extractor (E), supplied with machine, reach behind eccentric (B) as shown and withdraw eccentric. It may be necessary to move handwheel back and forth slightly during extraction.

SETTING THE DIFFERENTIAL RATIO

Differential feed action is obtainable thru the use of one micrometer adjusting screw on Style 39500 JP and two micrometer adjusting screws on Style 39500 FS, FT, FU, GD, GL and GT.

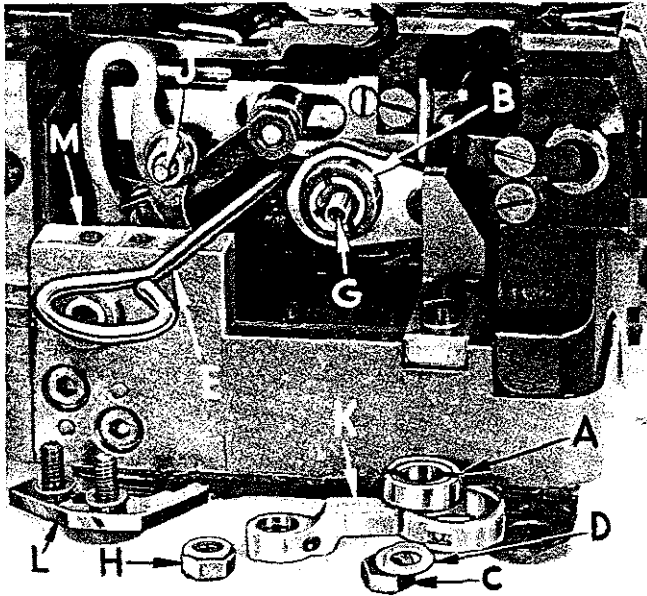

Fig. 14

On Styles 39500 FS, FT, FU, GD, GL and GT, the differential feed action is also controlled by the movement of the differential control lever between an upper and a lower stop, but on these machines both stops are moved by an adjusting thumbscrew rod.

To set the amount of differential or plain feed, turn the plain feed control adjusting rod, it is the larger knurled head screw located on the bed in back of the tension post assembly. Turning this rod clockwise decreases the amount of differential and turning it counterclockwise increases the amount of differential.

The amount of intermittent differential feed is set by turning the differential feed control adjusting rod, it is the smaller knurled head screw located just above the plain feed control adjusting rod. Turning this screw clockwise lowers the stop and thus increases the amount of differential, when the differential feed control lever is actuated. Turning this screw counterclockwise acts the reverse.

The position of the differential control lever (A, Fig. 15) is governed by an upper and a lower stop. The amount of lever movement between these two stops determines the feed action.

On Style 39500 JP, rotating the one adjusting thumbscrew (located near the tension post assembly) in a clockwise direction increases the differential action by moving the upper stop (B) down, a Counterclockwise turn acts in a reverse manner. Now set the lower stop screw (C) so as to obtain the required intermittent differential feed. On Style 39500 JP, the two stops may be reversed to meet a specific sewing requirement.

NOTE: After lower stop screw has been set, push differential control lever down, hold in this position and turn handwheel in operating direction to be sure the differential feed dog does not strike the throat plate.

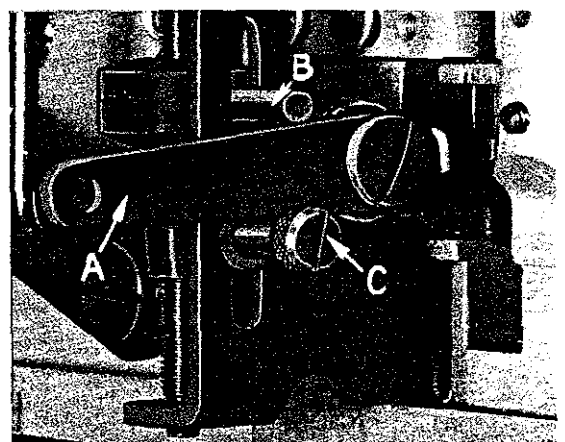

Fig. 15

SETTING THE PRESSER FOOT

Assemble the presser foot to presser arm. With needle in high position, swing presser arm into sewing position and set the presser foot to align needle holes (front and back) and flat on throat plate.

SETTING THE PRESSER FOOT (Continued)

The front edge of needle hole in presser foot must be aligned with front edge of needle hole in throat plate. It is also important that the bottom of the presser foot be flat on the throat plate. If necessary, presser foot can be realigned with throat plate slots by shifting the foot lifter lever shaft (H, Fig. 16). To move the shaft, loosen collar screws (B, Fig. 16) and clamp screw (G) and then shift the foot lifter lever shaft to the left or right as required. Retighten collar screws and clamp screw.

The foot lifter lever arm (A, Fig. 16) and the collar (B) secure the shaft. Be sure the presser arm does not bind or rise when presser foot release bushing is unlocked.

Adjust lifter lever stop screw (C) so that presser foot can be raised no higher than upper looper will permit: then lock the nut (D). There should be from 1/16 to 1/8 inch free motion of foot lifter lever before the presser foot begins to rise. This adjustment should be made with screw (E) and locked with nut (F). Re-assemble the chip guard, fabric guard and cloth plate. To assemble chip guard, turn handwheel until upper knife assembly reaches its highest position.

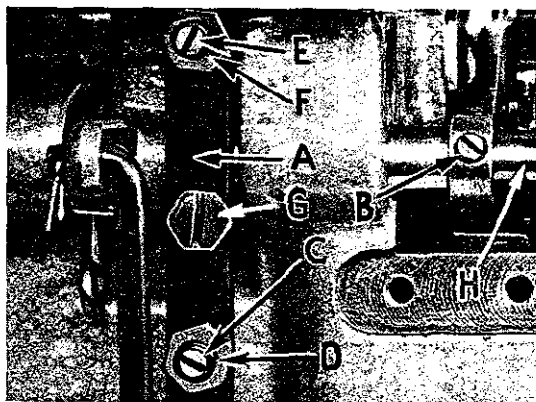

Fig. 16

SETTING THE PRESSER FOOT HOLD DOWN PLATE

Styles 39500 FT, FU, GL, GD and GT are equipped with a presser foot hold down plate (A, Fig. 17). The purpose of this plate is to hold down the rear of the presser foot and when set correctly it will help produce a more flat pucker free seam. An approximate setting is shown in Fig. 17. Set the machine with the feed dogs below the throat plate and insert a .005 inch shim (B) under the front portion of presser foot (C). Loosen screws (D) which hold the hold down plate in position and move the plate down until it rests firmly against the presser foot. Tighten the two screws and remove the shim.

NOTE: Always be sure the feed dogs are below surface of throat plate when making this setting.

SETTING THE AUXILIARY PRESSURE PLATE

Styles 39500 FT, FU, GD, GL and GT are equipped with an auxiliary pressure plate assembly (Fig. 18) which operates in conjunction with the presser foot.

To check the operation of this assembly as follows:

1. With assembly in operating position, check to be sure latch spring (C, Fig. 18) is in notch of shaft bracket (G) when shaft bracket is up against the front of bracket (C, Fig. 19). If adjustment is necessary loosen screws (H, Fig. 18) and position latch spring.
2. Swing assembly out of operating position and see that it hinges freely on its pivot. Adjustment is made for screw (A, Fig. 18) and nut (B).

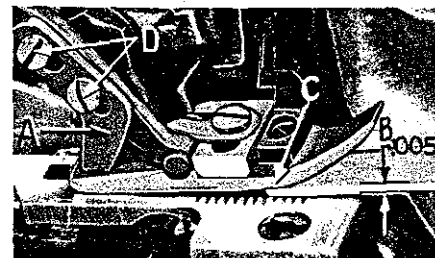

Fig. 17

SETTING THE AUXILIARY PRESSURE PLATE (Continued)

3. Adjust the shaft (D) laterally so that the pressure plate (E) locates centrally over the differential feed dog. Loosen screws (A and B, Fig. 19) to do this. Making this adjustment will release the spring tension on the pressure plate. To re-gain the tension, swing the pressure plate out and turn the shaft (D, Fig. 18) in either direction about 180° from operating position and tighten screw (B, Fig. 19).

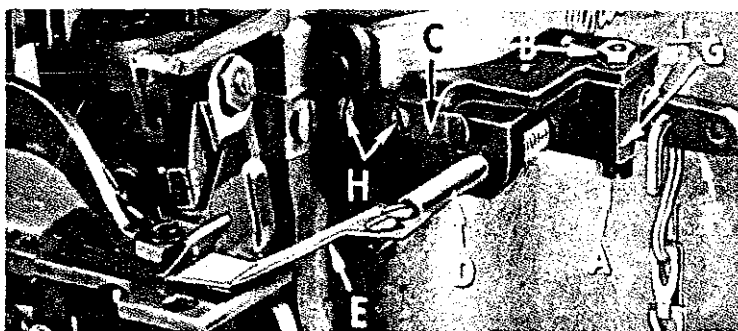

Fig. 18

4. With the differential feed dog down below the surface of the throat plate, and the pressure plate resting on the throat plate with the maximum pressure the spring will allow, there should be about 1/32 inch clearance between the operating lever (F, Fig. 18) and the hinge block (G). To make this adjustment loosen screw (A, Fig. 19) and move lever to desired position.
5. With the differential feed dog at its highest point of travel, raise or lower the mounting bracket (C, Fig. 19) so that the auxiliary pressure plate is parallel with feed dog teeth.
6. Adjust the pressure plate in or out towards presser foot, maintaining it parallel with the feed dog, so that there is sufficient clearance between the end of plate and presser foot to permit free passage of the thickest part of the top ply being sewn. Use screws (D, Fig. 19) for this adjustment.
7. There are two spring anchoring holes in collar (E, Fig. 19) which may be used for increasing or decreasing spring tension on auxiliary pressure plate.
8. A chain is provided for raising the auxiliary pressure plate in conjunction with the presser foot. Couple this chain from the operating lever (F, Fig. 18) to the knee press rod that is part of the knee press assembly used to lift the presser foot. The presser foot should be raised before the pressure plate and the chain is normally attached to the pressure plate operating lever at the side hole.

STARTING TO OPERATE

Be sure machine is threaded according to threading diagram (Fig. 1 or 1A, pages 6 or 7). With thread tension light, set looper thread eyelets (N and R) about horizontal and in the middle of their front to back locations. Operate machine slowly, without presser foot in place, to make sure that chain forms and moves off the tongue freely. Swing presser foot into position, insert material, and sew slowly.

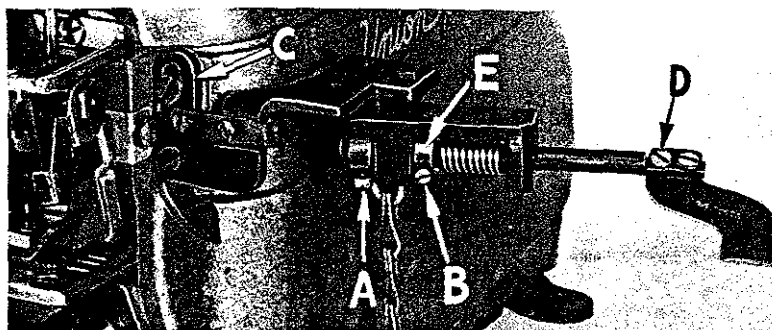

Fig. 19

NEEDLE THREAD CONTROL

While sewing on material, check needle thread control as follows: Usually all needle thread is drawn on needle down stroke. At top of needle stroke, thread should be just tight enough to feed chain off stitch tongue. Stitch tends to pull down slightly if excessive thread is pulled on the up stroke. With needle at bottom of stroke, position needle thread eyelet (AD, Fig. 1 or 1A) so that needle thread cam pull-off (AE) just contacts needle thread.

LOWER LOOPER THREAD CONTROL

With material under presser foot, set lower looper thread eyelet (R, Fig. 1 or 1A) back far enough so thread is a little slack when looper thread pull-off (AF) reaches its most rearward position. Looper thread pull-off (AF) is set about 1/8 inch distance behind needle thread cam pull-off (AE). Frame looper thread guide (T) should be set with its eyelet approximately 1/8 inch right of lower looper (V) heel eyelet at the time lower looper is at extreme left end of its travel.

While sewing on material, check drawing off of looper thread as follows: A portion of lower looper thread should be drawn through the tension before lower looper thread comes off upper looper. To increase amount of thread drawn through the tension while lower looper thread is on upper looper, move lower looper thread eyelet (R) down, keeping the same amount of pull-off action.

UPPER LOOPER THREAD CONTROL

Before proceeding to adjust upper looper thread eyelet (N, Fig. 1 or 1A) balance all three or four tensions to give a normal appearing stitch. Moderate change in these tensions will not markedly effect the purl.

During needle down stroke, forward stroke of looper thread pull-off (AF) will draw upper looper thread through the tension. When normal amount of looper thread is drawn, upper looper thread will have almost all slack taken up as looper thread pull-off reaches its most rearward position.

POSITIONING THE PURL

To move the purl more under the edge, both looper thread eyelets (N and R, Fig. 1 or 1A) should be raised keeping the same amount of pull-off. Usually it is better to have slightly more pull-off on upper thread than on lower thread.

If it becomes necessary to move looper thread pull-off (AF), be sure to take up all end play in needle drive shaft before tightening. If upper looper is located so that it is higher over throat plate than recommended in (Fig. 10), the purl will tend to form near top edge. If upper looper is too low, the purl will form nearer bottom edge.

THREAD TENSIONS

The needle thread tension required is a function of needle thread and material being sewn. In general, lower looper thread tension should be set as high as possible without causing needle thread to be pulled down. Upper looper thread tension should be increased as long as the elasticity of the chain increases, or until the purl is pulled too far over the top.

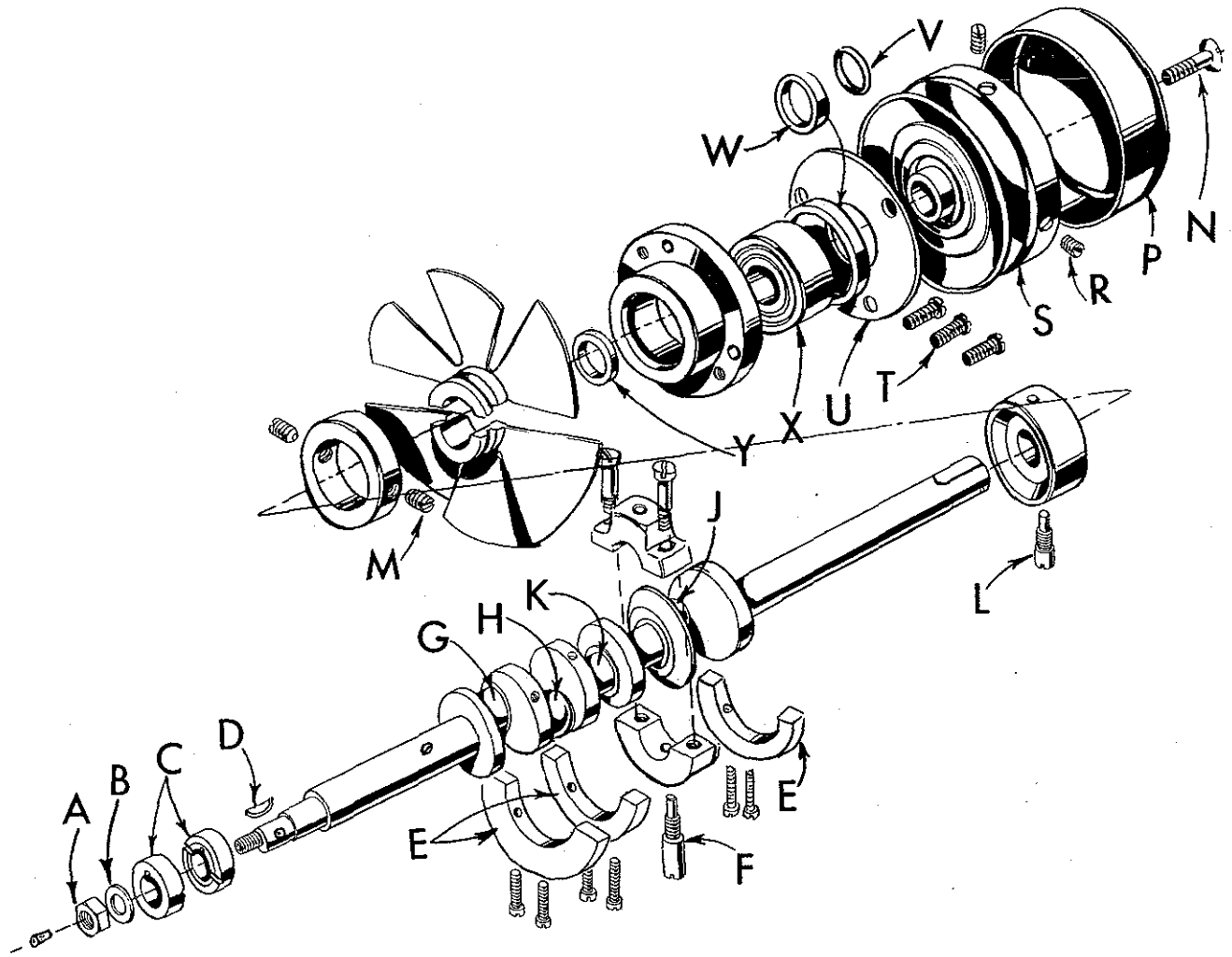

Fig. 20

TO REMOVE CRANKSHAFT

Crankshaft can be withdrawn easier if these steps are followed:

1. Drain oil by removing plug screw located on back of machine near bottom edge of base.
2. Remove top and bottom covers of machine.
3. Remove feed eccentric nut (A, Fig. 20) and washer (B), and, with the aid of the eccentric extractor, slip off the eccentrics (C).
4. Remove key (D).
5. Remove three counterweights (E). Identify these counterweights so that they will be re-assembled in the proper places.
6. Remove screw (F) which holds crankshaft split bearing. This screw is reached through bottom of bed casting.

TO REMOVE CRANKSHAFT (Continued)

7. Remove caps of bearings on crankshaft at points G, H, and J. When re-assembling bearing caps make sure they are in their original position. Trade marks are stamped on both halves of the caps and both trade marks should be on the same side of the bearings. Also, screws should be re-assembled in the same holes from which they were removed.

8. Loosen clamp nut (A, Fig. 21) which holds upper knife driving arm (B). Access to clamp nut is through top cover. Draw driving arm to the left until upper knife driving lever (C) and connecting rod (D) drop, allowing removal of bearing cap (E). This is at bearing point (K, Fig. 20) on crankshaft. Observe same precautions when re-assembling cap as described in 7 above.

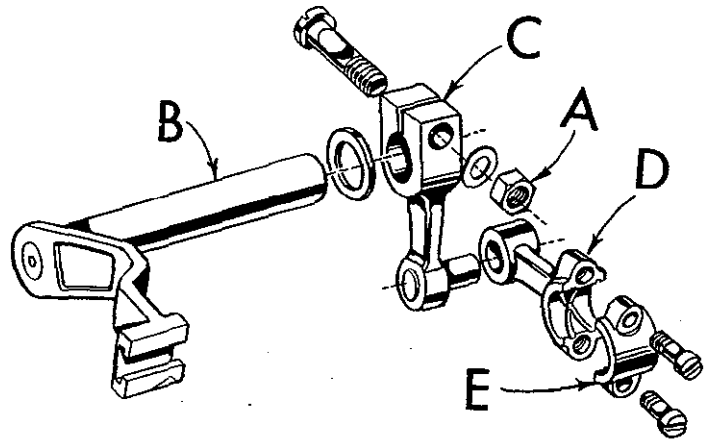

Fig. 21

9. Remove screw (L, Fig. 20) which holds inner right crankshaft bearing. This screw is reached through bottom of bed casting.
10. Loosen two screws (M) in fan collar; remove both halves of cooling fan.
11. Remove screw (N); take off pulley cap (P).
12. Loosen two screws (R); remove pulley (S).
13. Remove three screws (T); take off bearing retaining plate (U); also, spacer collars (V) and (W) may be removed at this time.
14. Crankshaft may now be removed.
15. If necessary to replace ball bearing (X), it should be pressed off shaft on an arbor press. In replacing bearing it must be pressed on carefully until it seats against ground thrust washer (Y).
16. Carefully observing reverse of the foregoing operations should simplify re-assembly of crankshaft. Checking exploded view drawings for location of various parts and constant testing for binds during re-assembly will also prove helpful.
17. Before re-assembling, thoroughly clean and dry top and bottom covers and gaskets. Before re-assembling bottom cover make sure that spring pressed oil wick which lubricates left crankshaft bearing is inserted in hole in casting and that it contacts shaft. The wick stands vertically on its spring against bottom cover. Coat oil drain plug with a sealing compound before re-assembling to prevent oil leakage. No. 1 Crane Lead Seal is recommended.

ORDERING REPAIR PARTS

ILLUSTRATIONS

This catalog has been arranged to simplify ordering repair parts. Exploded views of various sections of the mechanism are shown so that the parts may be seen in their actual position in the machine. On the page opposite the illustration will be found a listing of the parts with their part number, description, and the number of pieces required in the particular view being shown.

Numbers in the first column are reference numbers only, and merely indicate the position of that part in the illustration. Reference numbers should never be used in ordering parts. Always use the part number listed in the second column.

Component parts of sub-assemblies which can be furnished for repairs are indicated by indenting their descriptions under the description of the main sub-assembly. Example:

40	29126 DF	Lower Looper Bar Driving Lever and Connecting Rod Assembly-----	1
41	22729 D	Screw, for No. 39544 N-----	2
42	97	Screw, for No. 39544 S-----	2
43	39544 S	Ball Joint Guide Fork-----	1
44	39544 U	Lower Looper Bar Driving Lever-----	1
45	22729 E	Screw, for No. 39544 N-----	2

It will be noted in the above example that the eccentric, ball stud, and bearing are not listed. The reason is that replacement of these parts individually is not recommended, so complete sub-assembly should be ordered.

At the back of the book will be found a numerical index of all the parts shown in this book. This will facilitate locating the illustration and description when only the part number is known.

IDENTIFYING PARTS

Where the construction permits, each part is stamped with its part number. On some of the smaller parts, and on those where the construction does not permit, an identification letter is stamped in to distinguish the part from similar ones.

Part numbers represent the same part, regardless of the catalog in which they appear.

USE GENUINE NEEDLES AND REPAIR PARTS

Success in the operation of these machines can be secured only with genuine Union Special Needles and Repair Parts as furnished by the Union Special Machine Company, its subsidiaries and authorized distributors. They are designed according to the most approved scientific principles, and are made with utmost precision. Maximum efficiency and durability are assured.

Genuine needles are packaged with labels marked *Union Special*. Genuine repair parts are stamped with a reproduction of the familiar Union Special trademark. Each trademark is your guarantee of the highest quality in materials and workmanship.

TERMS

Prices are net cash and are subject to change without notice. All shipments are forwarded f. o. b. shipping point. Parcel Post shipments are insured unless otherwise directed. A charge is made to cover postage and insurance.

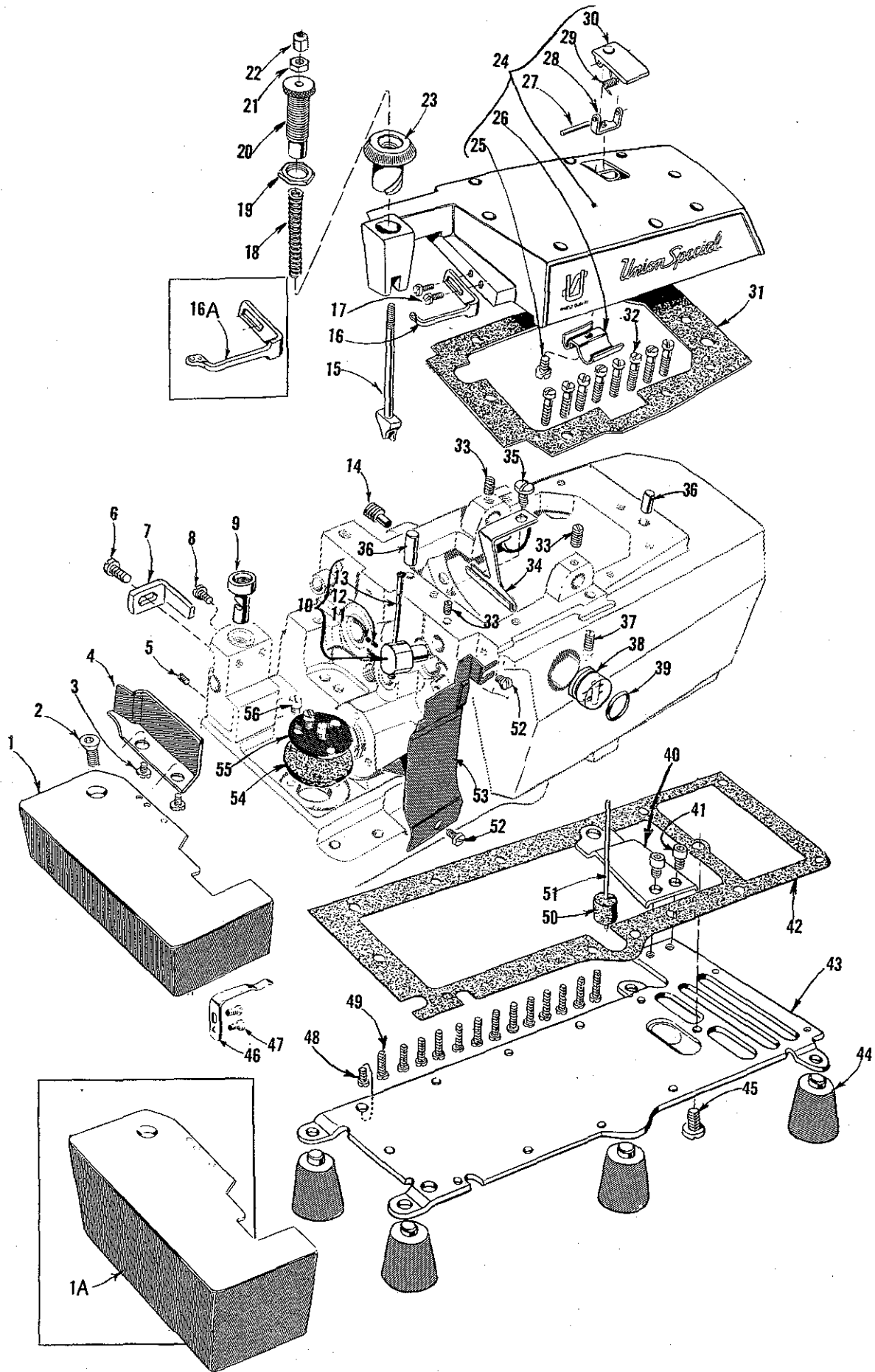

MAIN FRAME, MISCELLANEOUS COVERS AND PLATES

<u>Ref. No.</u>	<u>Part No.</u>	<u>Description</u>	<u>Amt. Req.</u>
1	39501 DC	Cloth Plate, for semi or fully submerged installations, for all Styles except 39500 JP -----	1
	39501 D	Cloth Plate, for semi or fully submerged installation, for Style 39500 JP -----	1
1A	39501 EC	Cloth Plate, for non-submerged installation, for all Styles except 39500 JP -----	1
	39501 E	Cloth Plate, for non-submerged installation, for Style 39500 JP ---	1
2	22657 D-12	Screw, for cloth plate -----	1
3	138	Screw, for cloth plate fabric guard -----	2
4	39578 K	Cloth Plate Fabric Guard -----	1
5	22565 F	Screw, for feed adjusting pin -----	1
6	22569 C	Screw, for feed bar guide -----	1
7	39535 H	Feed Bar Guide -----	1
8	22569	Screw, for cloth plate stud-----	1
9	39501 K	Cloth Plate Stud -----	1
10	29477 GW	Upper Looper Thread Tube Assembly -----	1
11	22743	Screw, for thread tube tension spring -----	1
12	39568 J	Thread Tube Tension Spring -----	1
13	39568 G	Thread Tube -----	1
14	22571 E	Magnetic Oil Drain Plug Screw -----	1
15	39557 A	Presser Spring Plunger -----	1
16	39563 F	Top Cover Needle Thread Eyelet, for Styles 39500 FS, FT, FU, GT, JP -----	1
16A	39563 W	Top Cover Needle Thread Eyelet, for Styles 39500 GD, GL-----	1
17	22569 B	Screw, for top cover needle thread eyelet -----	2
18	39557	Presser Spring -----	1
19	39557 F	Lock Nut, for presser spring plunger adjusting screw -----	1
20	39557 C	Presser Spring Plunger Adjusting Screw -----	1
21	39557 E	Presser Spring Plunger Locking Nut -----	1
22	39557 B	Presser Spring Plunger Cap Nut-----	1
23	39556 A	Presser Foot Release Bushing -----	1
24	39582 AD	Top Cover, for Style 39500 FS, FT, FU, GT, JP -----	1
	39582 AK	Top Cover, for Styles 39500 GD, GL-----	1
25	22562 A	Screw, for oil guard -----	1
26	39582 W	Oil Guard -----	1
27	51-103 Blk.	Hinge Pin -----	1
28	39582 AG	Hinge Bracket -----	1
29	39582 V	Spring -----	1
30	39582 AF	Oil Filler Cover -----	1
31	39582 AE	Top Cover Gasket -----	1
32	22541	Screw, for top cover -----	8
33	22565	Screw, for upper looper thread tube assembly -----	3
34	39594 R	Oil Collector Plate -----	1
35	22569 D	Screw, for oil collector plate -----	1
36	667 D-8	Dowel Pin -----	2
37	22894 AD	Screw, for lower looper bar driving lever shaft -----	2
38	39593 H	Oil Sight Gauge -----	1
39	660-243	Oil Gauge Seal Ring -----	1
40	39582 F	Bottom Cover and Base Plate Extension -----	1
41	22653 D-4	Screw, for bottom cover extension -----	2
42	39582 Y	Bottom Cover Gasket -----	1
43	39582 X	Bottom Cover -----	1
44	39595	Rubber Isolator-----	4
45	22586 R	Screw, for bottom cover-----	1
46	39532 A	Cloth Plate Latch Spring-----	1
47	90	Screw, for cloth plate latch spring-----	2
48	22569 C	Screw, for bottom cover-----	1
49	22569	Screw, for bottom cover-----	13
50	39593 C	Oil Gauge Float -----	1
51	39593 D	Oil Gauge Indicator -----	1
52	22569 D	Screw, for chip guard -----	1
53	39578 W	Chip Guard -----	1
54	39594 H	Oil Strainer -----	1
55	39594 G	Oil Filter Screen -----	1
56	22569 A	Screw, for oil filter screen-----	3

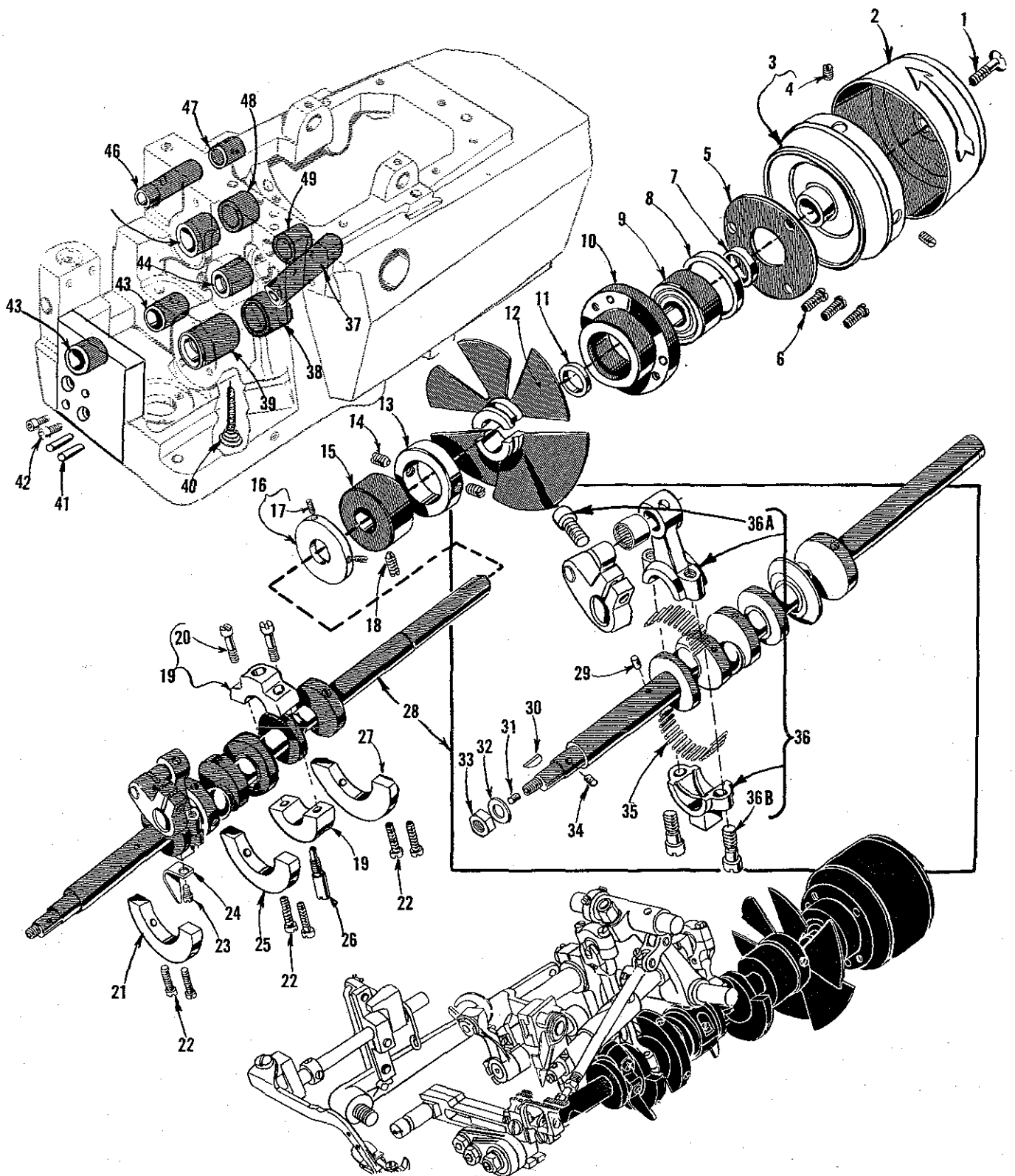

CRANKSHAFT MECHANISM AND BUSHINGS

Ref. No.	Part No.	Description	Amt. Req.
1	22769 B	Screw, for pulley cap -----	1
2	39521 D	Pulley Cap -----	1
3	39521 C	Pulley -----	1
4	95	Screw, for pulley -----	2
5	39590 H	Crankshaft Ball Bearing Retaining Plate -----	1
6	22541 A	Screw, for crankshaft ball bearing retaining plate -----	3
7	39590 S	Spacer Collar -----	1
8	39590 R	Ball Bearing Stop Collar -----	1
9	660-268	Ball Bearing -----	1
10	39590 G	Crankshaft Ball Bearing Housing -----	1
11	39590 J	Thrust Washer -----	1
12	39591 G	Crank Chamber Cooling Fan -----	1
13	39591 H	Crank Chamber Cooling Fan Collar -----	1
14	22894 D	Screw, for crank chamber cooling fan collar -----	2
15	39590 K	Crankshaft Bearing, inner right -----	1
16	39590 P	Oil Slinger Collar -----	1
17	77 Q	Screw, for oil slinger collar -----	2
18	22565 F	Screw, for crankshaft bearing inner right -----	1
19	39590 D	Crankshaft Split Bearing -----	1
20	97 A	Screw, for crankshaft split bearing -----	2
21	39591 K	Crankshaft Counterweight, left -----	1
22	22747 B	Screw, for crankshaft counterweights -----	6
23	28	Screw, for oil splasher -----	1
24	39594 N	Oil Splasher -----	1
25	39591 A	Crankshaft Counterweight, middle -----	1
26	39590 N	Stud, for crankshaft split bearing -----	1
27	39591 B	Crankshaft Counterweight, right -----	1
28	29477 KE	Crankshaft and Needle Driving Arm Assembly, for all Styles except 39500 JP -----	1
	29477 JM	Crankshaft and Needle Driving Arm Assembly, for Style 39500 JP -----	1
29	51-228 Blk.	Vent Plug -----	1
30	39541 A	Feed Driving Eccentric Key -----	1
31	CO67 E	Cork Plug -----	1
32	40-46	Washer -----	1
33	258	Nut -----	1
34	30-92 Blk.	Wood Plug -----	1
35	39516-625	Needle Bearing, .0625 inch diameter -----	28
	39516-626	Needle Bearing, .0626 inch diameter -----	28
	39516-627	Needle Bearing, .0627 inch diameter -----	28
36	29477 JN	Needle Driving Arm Crank and Connecting Rod Assembly --	1
36A	22596 G	Screw, for needle driving arm crank -----	1
36B	22587 M	Screw, for needle driving arm connecting rod -----	2
37	39544 L	Lower Looper Bar Bushing -----	1
38	39590 T	Crankshaft Bearing, inner left -----	1
39	39590	Crankshaft Bearing, left -----	1
40	666-94	Oil Wick and Spring -----	1
41	667 B-12	Dowel Pin -----	2
42	22653 B-12	Socket Head Cap Screw -----	2
43	43243 N	Differential Feed Rocker Shaft Bushing -----	2
44	39552 N	Needle Driving Arm Crank Bushing, left -----	1
45	39573 K	Upper Knife Driving Arm Bushing, left -----	1
46	39555 E	Foot Lifter Shaft Bushing, left -----	1
47	39142 G	Foot Lifter Shaft Bushing, right -----	1
48	39573 L	Upper Knife Driving Arm Bushing, right -----	1
49	39552 P	Needle Driving Arm Crank Bushing, right -----	1

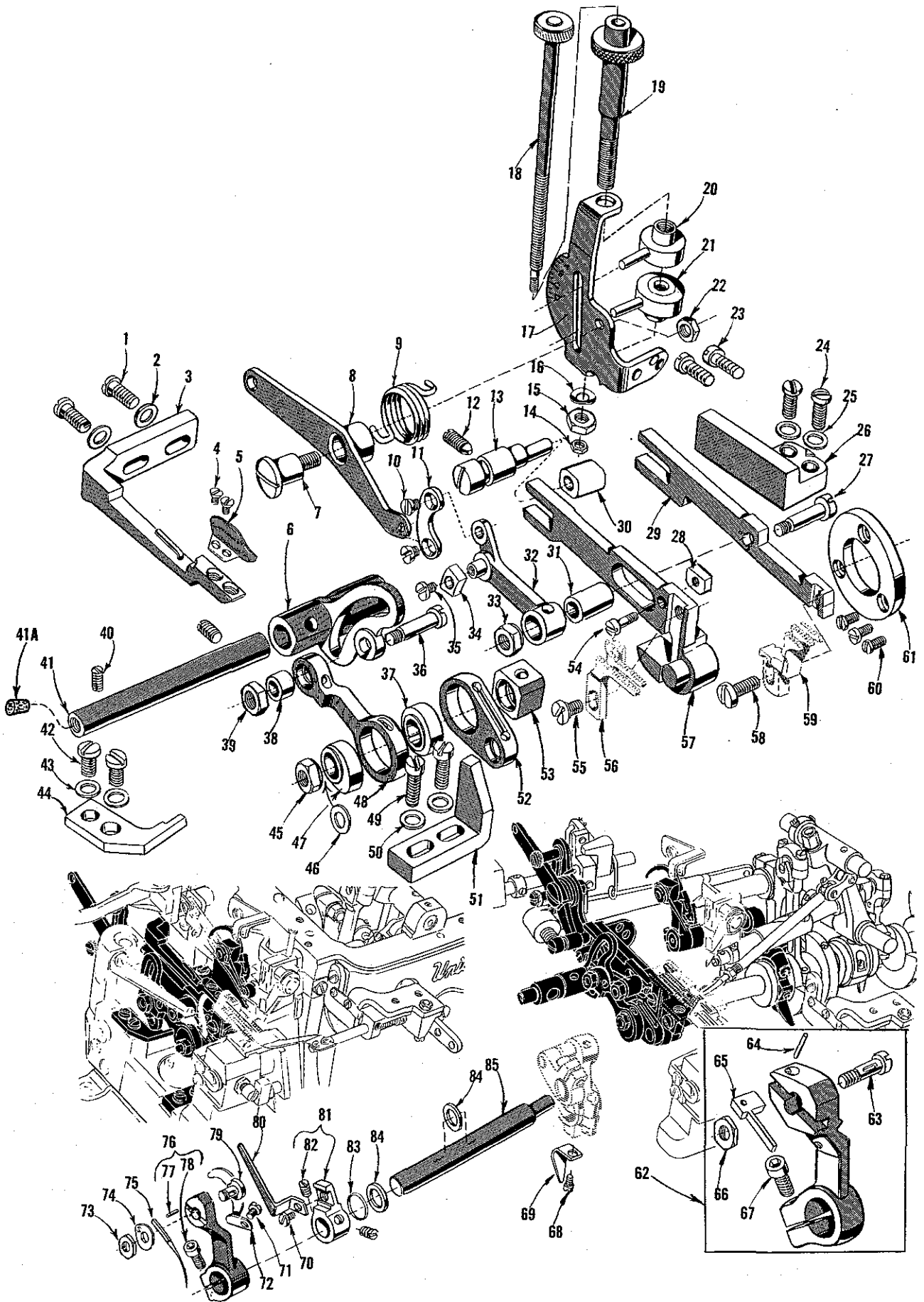

NEEDLE DRIVE AND FEED MECHANISM

<u>Ref. No.</u>	<u>Part No.</u>	<u>Description</u>	<u>Amt. Req.</u>
1	22569 B	Screw, for fabric guard mounting bracket -----	2
2	8372 A	Washer, for fabric guard mounting bracket-----	2
3	39578 P	Fabric Guard Mounting Bracket -----	1
4	87	Screw, for fabric guard -----	2
5	39578 M	Fabric Guard -----	1
6	39536 L	Differential Feed Rocker -----	1
7	22557 E	Screw, for differential feed control lever-----	1
8	39536 U	Differential Feed Control Lever -----	1
9	39536 V	Differential Feed Control Spring-----	1
10	39536 Y	Screw, for control lever connecting link-----	2
11	39536 W	Control Lever Connecting Link -----	1
12	22565 F	Screw, for feed adjusting pin -----	1
13	39535 E	Feed Adjusting Pin -----	1
14	12934 A	Lock Nut, for differential feed control adjust- ing rod -----	1
15	39536 AH	Friction Nut, for differential feed control adjusting rod-----	1
16	39198 D	Spring Washer-----	1
17	39636	Differential Feed Control Mounting Bracket for all Styles except 39500 JP -----	1
	39536 AJ	Differential Feed Control Mounting Bracket for Style 39500 JP -----	1
18	39636 C	Differential Feed Control Adjusting Rod -----	1
19	39636 A	Plain Feed Control Adjusting Rod-----	1
20	39636 B	Plain Feed Control Adjustable Stop -----	1
21	39636 D	Differential Feed Control Adjustable Stop-----	1
22	18	Nut, for differential feed control lever screw --	1
23	22569 C	Screw, for differential feed control mounting bracket -----	2
24	22569 B	Screw, for feed bar guide, right-----	2
25	53634 C	Washer, for feed bar guide, right -----	2
26	39535 D	Feed Bar Guide, right-----	1
27	39536 S	Differential Feed Bar Driving Stud-----	1
28	39536 X	Differential Feed Bar Guide Block -----	1
29	39534 B	Differential Feed Bar -----	1
30	39535 J	Main and Differential Feed Bar Guide Block ---	1
31	39536 R	Feed Bar Driving Connection Bushing -----	1
32	39536 P	Differential Feed Drive Link -----	1
33	39536 E	Nut, for differential feed bar driving stud -----	1
34	39536 N	Differential Feed Regulating Sliding Block -----	1
35	28	Screw, for differential feed regulating sliding block -----	1
36	39536 J	Differential Feed Drive Connecting Rod Stud---	1
37	39540 B-12	Main Feed Driving Eccentric, for Style 39500 JP -----	1
	39540 B-14	Main Feed Driving Eccentric, for Styles 39500 FS, FT, FU, GD, GL-----	1
	39540 B-16	Main Feed Driving Eccentric, for Style 39500 GT -----	1
38	39536 K	Feed Rocker Drive Connecting Bushing -----	1
39	39536 E	Nut, for differential feed drive connecting rod stud -----	1

40 to 85

See following page

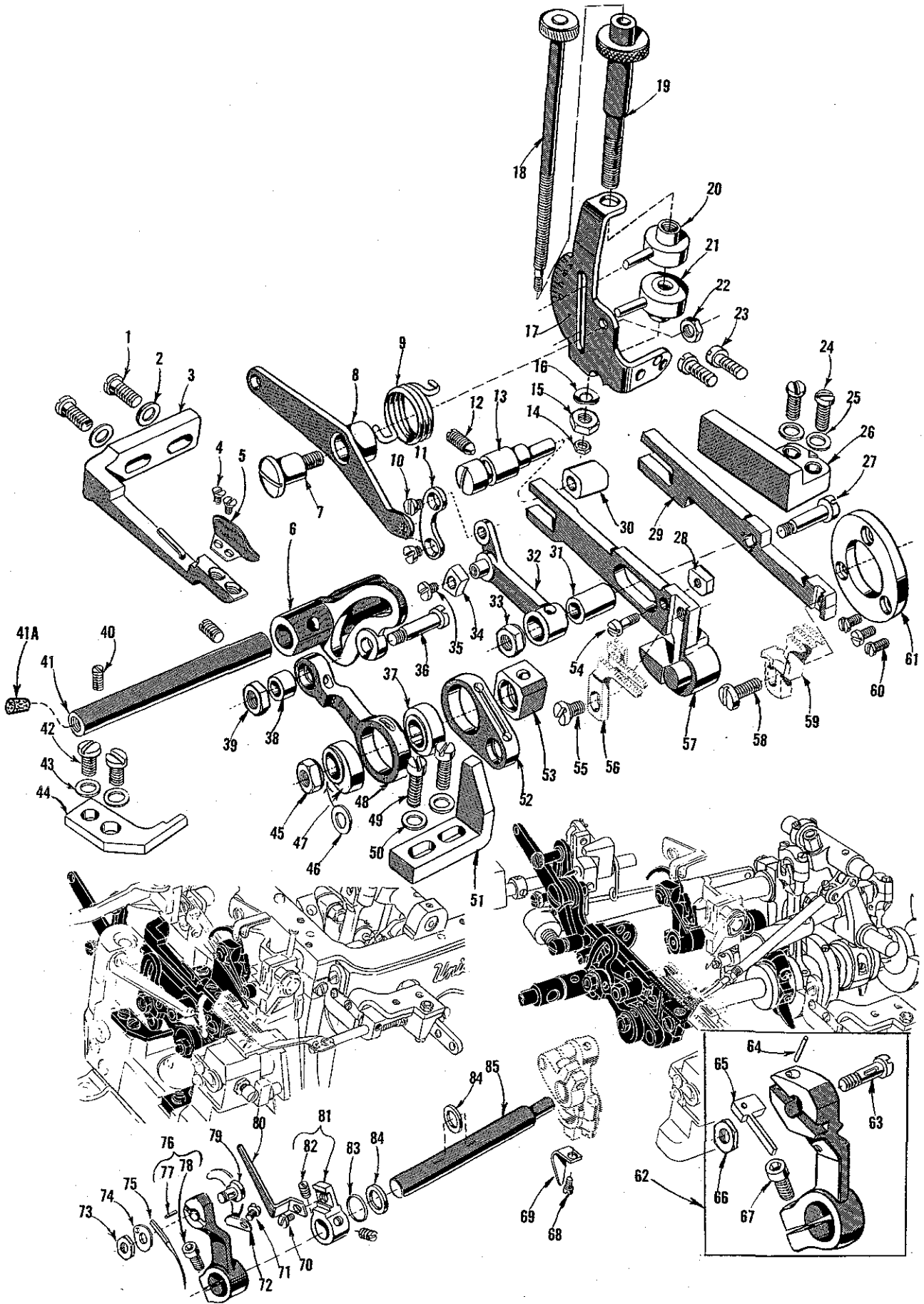

NEEDLE DRIVE AND FEED MECHANISM

<u>Ref. No.</u>	<u>Part No.</u>	<u>Description</u>	<u>Amt. Req.</u>
40	22565 B	Screw, for differential feed rocker shaft -----	2
41	39536 M	Differential Feed Rocker Shaft -----	1
41A	CO67 F	Cork, for differential feed rocker shaft-----	1
42	22569 C	Screw, for thrust finger -----	2
43	53634 C	Washer, for thrust finger -----	2
44	39536 H	Thrust Finger -----	1
45	258	Nut, for crankshaft-----	1
46	40-46	Washer, for crankshaft-----	1
47	39540 B-4	Differential Feed Driving Eccentric, for Styles 39500 FS, FT, GD -----	1
	39540 B-6	Differential Feed Driving Eccentric, for Styles 39500 GT, JP, -	1
	39540 C	Differential Feed Driving Eccentric, for Styles 39500 FU, GL,-	1
48	39536 F	Differential Feed Drive Connecting Rod, for Styles 39500 FS, FT, GD, GT, JP-----	1
	39536 G	Differential Feed Drive Connecting Rod, for Styles 39500 FU, GL -----	1
49	22569	Screw, for feed bar guide, left -----	2
50	8372 A	Washer, for feed bar guide, left -----	2
51	39535 G	Feed Bar Guide, left -----	1
52	39536 AF	Main Feed Bar Driving Connection-----	1
53	39538	Feed Lift Block -----	1
54	22726 L	Screw, for differential feed bar guide block -----	1
55	94	Screw, for main feed dog -----	1
56		Main Feed Dog (See Page 35)-----	1
57	39534 A	Main Feed Bar-----	1
58	93	Screw, for differential feed dog, for all Styles except 39500 JP -----	1
	22528	Screw, for differential feed dog, for Style 39500 JP-----	1
59		Differential Feed Dog (See Page 35)-----	1
60	22569 G	Screw, for feed bar thrust washer -----	3
61	39534 H	Feed Bar Thrust Washer -----	1
62	39552 T	Needle Driving Arm Assembly, for Styles 39500 GD, GL -----	1
63	39551 F	Needle Clamp Stud -----	1
64	50-774 Blk.	Stop Pin-----	1
65	39551 G	Needle Spacer -----	1
66	14077	Nut, for needle clamp stud -----	1
67	22596 E	Screw, for needle driving arm-----	1
68	28	Screw, for oil splasher -----	1
69	39594 N	Oil Splasher -----	1
70	22513	Screw, for looper thread pull-off -----	1
71	87 U	Screw, for needle thread pull-off -----	1
72	39563 G	Needle Thread Pull-off -----	1
73	14077	Nut, for needle clamp stud -----	1
74	39551 A	Needle Clamp Washer, for Styles 39500 FS, FT, FU, GT, JP--	1
75		Needle -----	1 or 2
76	39552	Needle Driving Arm, for Styles 39500 FS, FT, FU, GT, JP ---	1
77	50-774 Blk.	Stop Pin -----	1
78	22596 E	Screw, for needle driving arm -----	1
79	39551 F	Needle Clamp Stud, for Styles 39500 FS, FT, FU, GT, JP-----	1
80	39568 A	Looper Thread Pull-off -----	1
81	39568 Y	Looper Thread Pull-off Lever-----	1
82	88 B	Screw, for looper thread pull-off lever -----	2
83	660-207	Oil Seal Ring, for needle driving shaft -----	1
84	39552 C	Needle Driving Arm Crank Thrust Washer -----	2
85	39552 R	Needle Driving Shaft -----	1

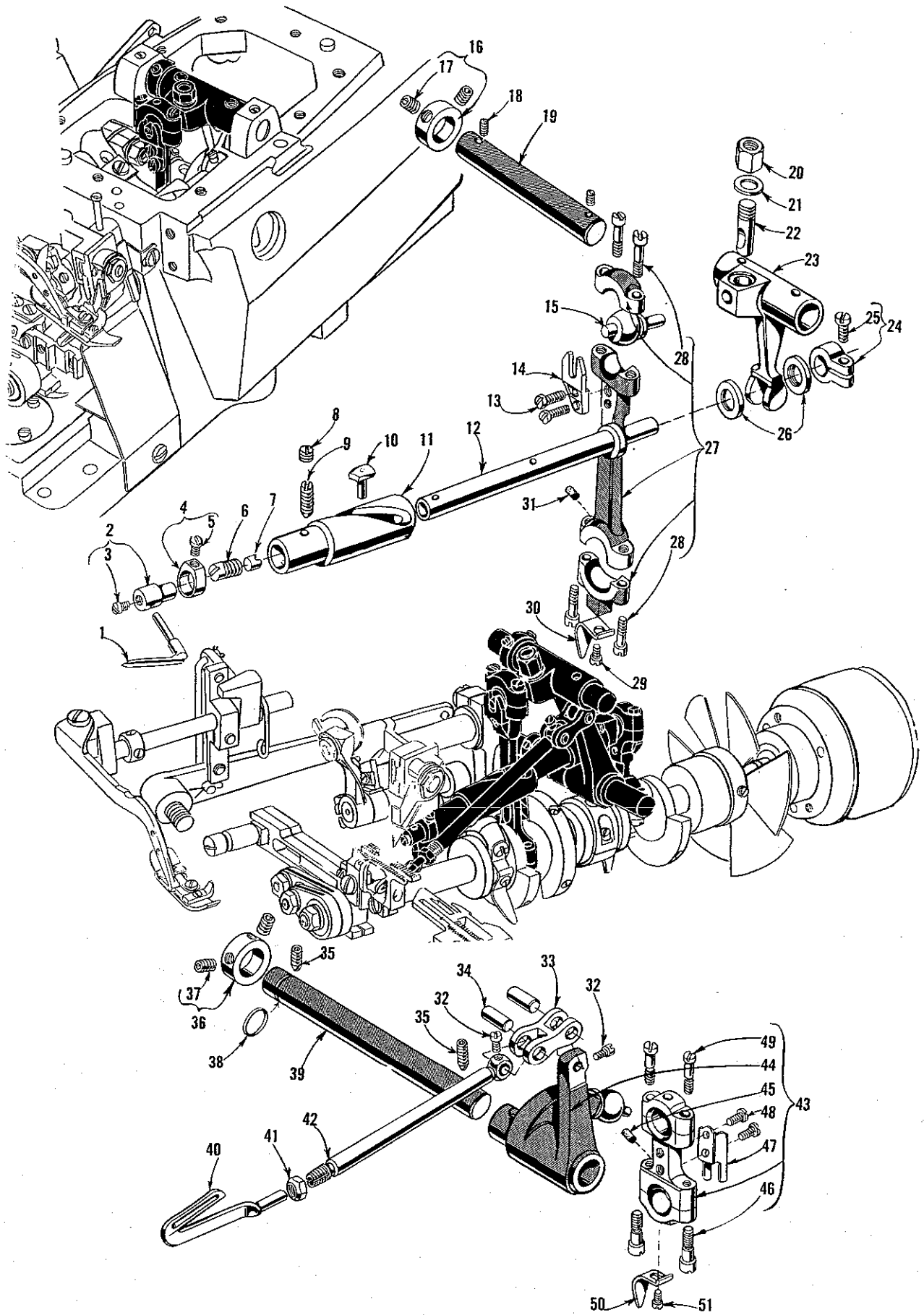

UPPER AND LOWER LOOPER DRIVING PARTS

<u>Ref. No.</u>	<u>Part No.</u>	<u>Description</u>	<u>Amt. Req.</u>
1	39508 A	Upper Looper, marked "CC"-----	1
2	39543	Upper Looper Holder-----	1
3	22564 G	Screw, for upper looper holder-----	1
4	39543 A	Upper Looper Holder Collar -----	1
5	22 KH	Screw, for upper looper holder collar-----	1
6	22503 F	Adjusting Screw, for cam follower locking clamp-----	1
7	39543 E	Cam Follower Locking Clamp -----	1
8	1025 L	Lock Screw, for bushing and cam guide -----	1
9	22565 H	Screw, for bushing and cam guide -----	1
10	39543 T	Cam Follower -----	1
11	39543 S	Upper Looper Bushing and Cam Guide-----	1
12	39543 K	Upper Looper Drive Shaft-----	1
13	97	Screw, for upper looper ball joint fork -----	2
14	39544 J	Upper Looper Ball Joint Fork -----	1
15	39543 V	Upper Looper Drive Ball Stud -----	1
16	482 C	Upper Looper Shaft Collar -----	1
17	22894 C	Screw, upper looper shaft collar -----	2
18	22565	Screw, for upper looper rocker shaft -----	2
19	7446 A	Upper Looper Drive Lever Shaft-----	1
20	1280	Nut, for locking stud -----	1
21	39543 R	Washer, for locking stud -----	1
22	43143 N	Locking Stud, for upper looper drive ball stud ---	1
23	39543 H	Upper Looper Drive Lever-----	1
24	39543 M	Clamp Collar, for upper looper drive shaft-----	1
25	22562 A	Screw, for clamp collar -----	1
26	39543 P	Thrust Washer, for upper looper drive shaft-----	2
27	39543 U	Upper Looper Connecting Rod-----	1
28	22729 D	Screw, for upper looper connecting rod -----	4
29	28	Screw, for oil splasher-----	1
30	39594 N	Oil Splasher-----	1
31	666-255	Felt Plug, for connecting rod -----	1
32	77	Screw, for lower looper bar connecting link -----	2
33	39544 B	Lower Looper Bar Connecting Link -----	1
34	39544 D	Lower Looper Bar Connecting Link Pin -----	2
35	22894 AD	Screw, for lower looper shaft -----	2
36	482 C	Lower Looper Shaft Collar -----	1
37	22894 C	Screw, for lower looper shaft collar -----	2
38	660-206	"O" Ring, for lower looper shaft -----	1
39	39544 V	Lower Looper Shaft -----	1
40	39508 B	Lower Looper-----	1
41	39151	Nut, for lower looper bar -----	1
42	39544	Lower Looper Bar -----	1
43	29126 DF	Lower Looper Bar Driving and Connecting Rod Assembly -----	1
44	39544 U	Lower Looper Bar Driving Lever-----	1
45	666-255	Felt Plug, for connecting rod -----	1
46	22729 E	Screw, for connecting rod -----	2
47	39544 S	Ball Joint Guide Fork -----	1
48	97	Screw, for ball joint guide fork-----	2
49	22729 D	Screw, for connecting rod -----	2
50	28	Screw, for oil splasher -----	1
51	39594 N	Oil Splasher -----	1

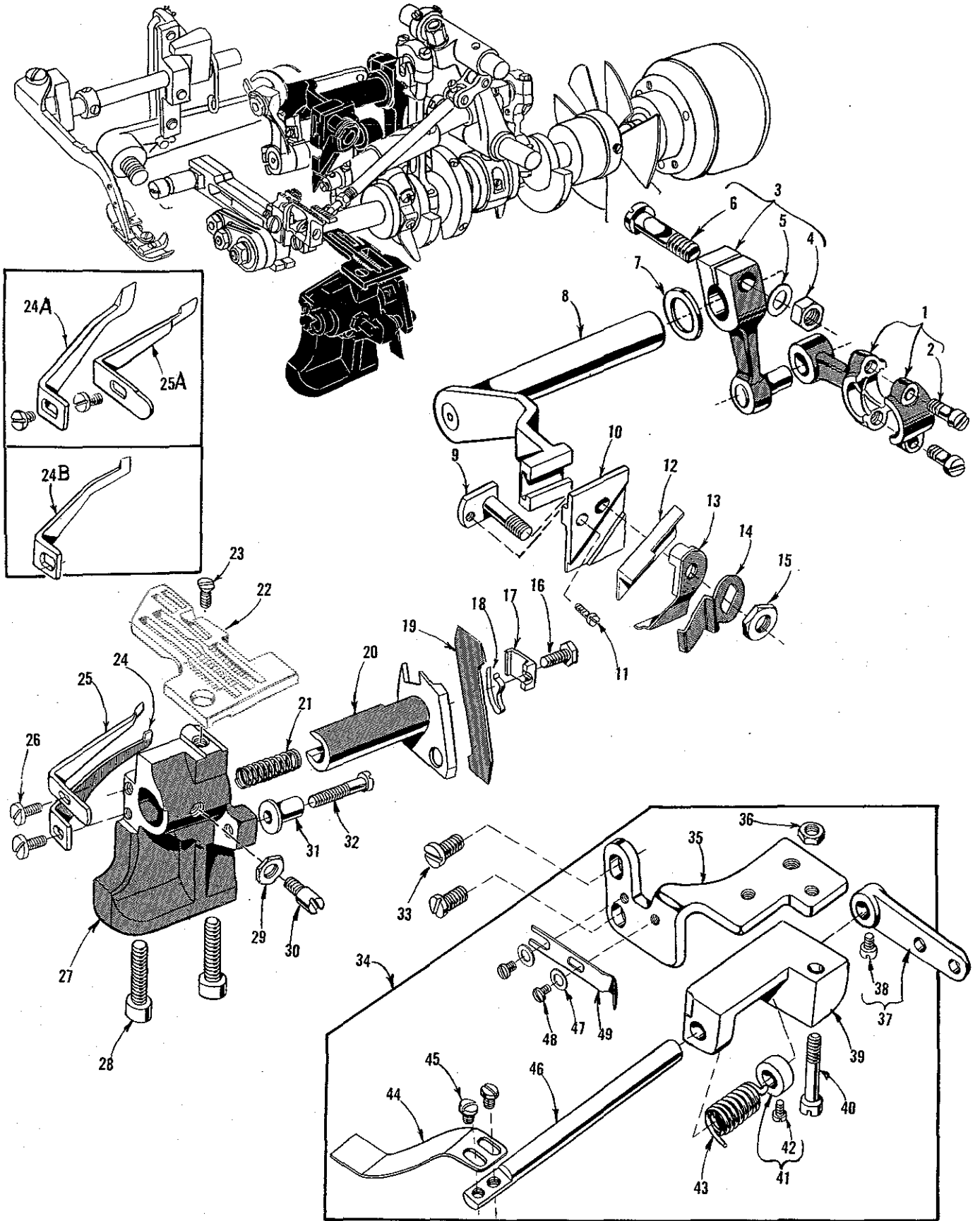

UPPER AND LOWER KNIFE MECHANISM AND PRESSURE PLATE ASSEMBLY

<u>Ref. No.</u>	<u>Part No.</u>	<u>Description</u>	<u>Amt. Req.</u>
1	39573 J	Upper Knife Drive Connecting Rod-----	1
2	22587 J	Screw, for upper knife drive connecting rod-----	2
3	39573 E	Upper knife Driving Lever -----	1
4	55235 E	Nut, for upper knife driving lever -----	1
5	6042 A	Washer, for upper knife driving lever -----	1
6	55235 D	Locking Stud, for upper knife driving lever -----	1
7	39573 A	Upper Knife Driving Arm Washer -----	1
8	39573 H	Upper Knife Driving Arm -----	1
9	39571 C	Upper Knife Clamp Stud, for Styles 39500 FT, FU -----	1
	39571 D	Upper Knife Clamp Stud, for Styles 39500 FS, GD, GL, GT, JP -----	1
10	39572 A	Upper Knife Holder Block, for Styles 39500 FT, FU-----	1
	39572	Upper Knife Holder Block, for Styles 39500 FS, GD, GL GT, JP -----	1
11	22738	Screw, for upper knife clamp stud -----	1
12	39570 J	Upper Knife, for all Styles except 39500 JP-----	1
	39570	Upper Knife, for Style 39500 JP-----	1
13	39571 F	Upper Knife Clamp -----	1
14	39571 B	Upper Knife Chain Guard-----	1
15	14077	Nut, for upper knife clamp stud -----	1
16	22588 A	Screw, for lower knife clamp -----	1
17	39550 L	Lower Knife Clamp -----	1
18	39550 M	Lower Knife Clamp Spring-----	1
19	39549 J	Lower Knife, for all Styles except 39500 JP -----	1
	39549	Lower Knife, for Style 39500 JP-----	1
20	39550 N	Lower Knife Holder-----	1
21	39550 E	Lower Knife Holder Spring -----	1
22		Throat Plate (See Page 35)-----	1
23	22524	Screw, for throat plate -----	1
24	39525	Needle Guard, front, for Styles 39500 FS, FT, FU, GT, JP -----	1
24A	39525 F	Needle Guard, front, for Style 39500 GL-----	1
24B	39525 M	Needle Guard, front, for Style 39500 GD-----	1
25	39525 A	Needle Guard, rear, for Styles 39500 FS, FT, FU, GT, JP-----	1
25A	39525 G	Needle Guard, rear, for Styles 39500 GD, GL-----	1
26	22585 A	Screw, for needle guard-----	2
27	39580 A	Throat Plate and Lower Knife Support Bracket -----	1
28	22653 B-12	Screw, for throat plate and lower knife support bracket--	2
29	14077	Nut, for lower knife holder locking screw-----	1
30	22892 B	Locking Screw, for lower knife holder-----	1
31	39550 C	Lower Knife Holder Locating Stud-----	1
32	22729 B	Screw, for lower knife holder locating stud -----	1
33	22569 C	Screw, for pressure plate assembly-----	1
34	29480 DC	Pressure Plate Assembly, for Styles 39500 FT, FU, GD, GL, GT -----	1
35	39531 AS	Bracket -----	1
36	907	Nut, for hinge screw -----	1
37	39531 AR	Lever-----	1
38	77 A	Screw, for lever -----	1
39	39531 AT	Shaft Bracket-----	1
40	22582	Hinge Screw-----	1
41	39531 B	Collar -----	1
42	604	Screw, for collar -----	1
43	39531 C	Spring -----	1
44	39531	Pressure Plate -----	1
45	22561	Screw, for pressure plate-----	2
46	39531 A	Shaft-----	1
47	41358 G	Washer for pressure plate -----	2
48	605 A	Screw, for latch spring -----	2
49	39531 E	Latch Spring-----	1

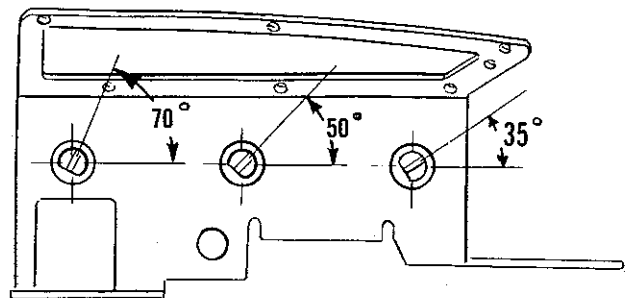
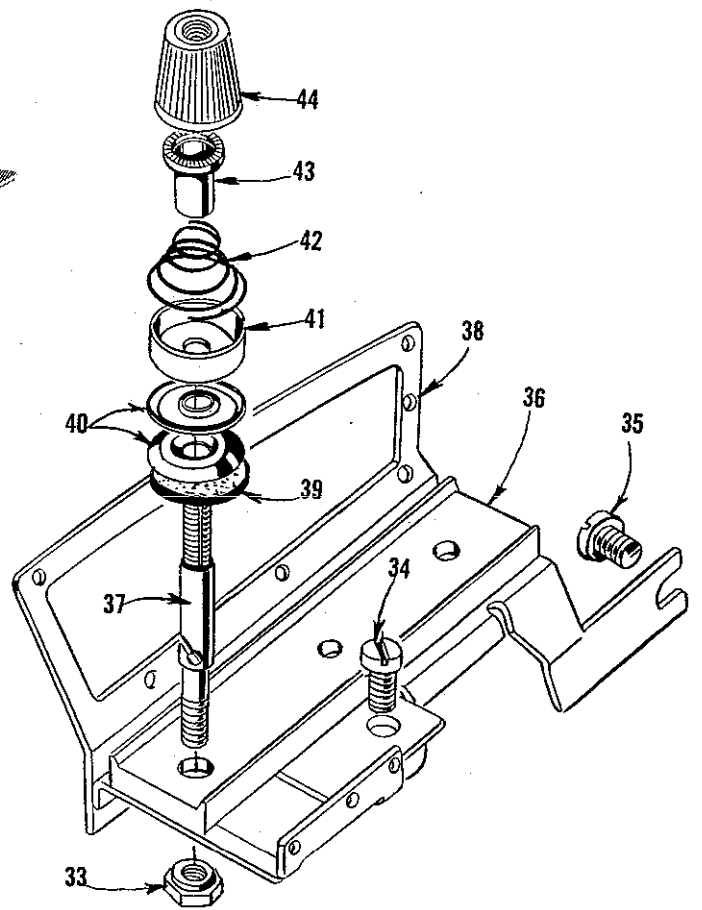
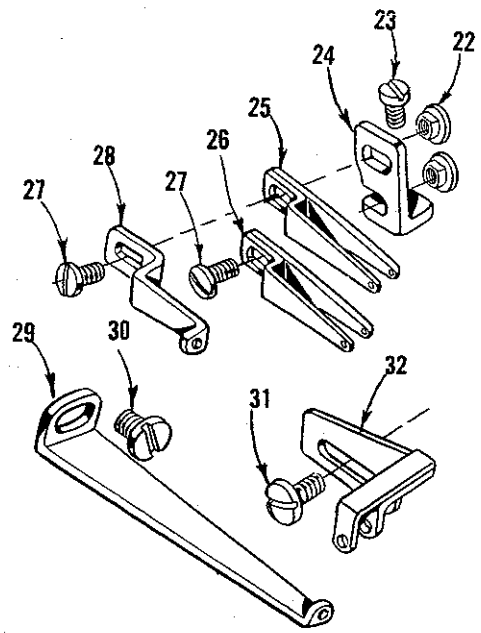
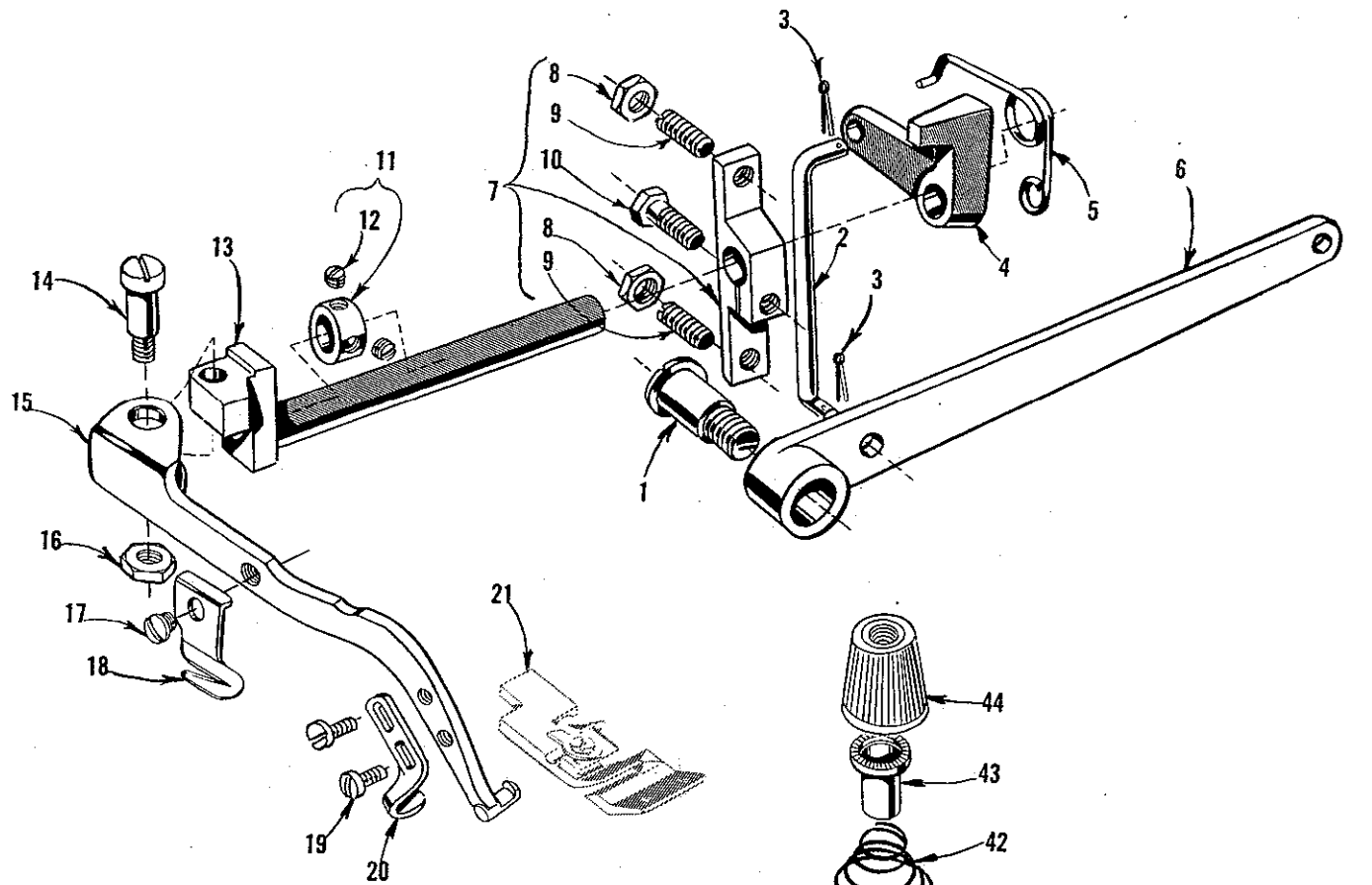

PRESSER FOOT LIFTER, THREAD TENSION AND MISCELLANEOUS EYELETS

<u>Ref. No.</u>	<u>Part No.</u>	<u>Description</u>	<u>Amt. Req.</u>
1	22566 B	Screw, for foot lifter lever -----	1
2	39555 F	Foot Lifter Lever Connecting Link-----	1
3	660-142	Cotter Pin, for foot lifter lever connecting link -----	2
4	39555 D	Foot Lifter Intermediate Lever-----	1
5	39555 B	Foot Lifter Lever Spring -----	1
6	39555	Foot Lifter Lever -----	1
7	39555 C	Foot Lifter Lever Arm -----	1
8	12538	Lock Nut, for -----	2
9	22597 E	Screw, for foot lifter lever arm -----	2
10	627	Screw, for foot lifter lever arm -----	1
11	12865	Thrust Collar, for foot lifter lever shaft -----	1
12	88	Screw, for thrust collar -----	2
13	39555 A	Foot Lifter Lever Shaft-----	1
14	22598 E	Screw, for presser arm -----	1
15	39556 F	Presser Arm -----	1
16	14077	Nut, for presser arm screw -----	1
17	22704	Screw, for chain cutting knife -----	1
18	39556 K	Chain Cutting Knife, for Style 39500 GD, GL-----	1
19	605 A	Screw, for presser foot hold down plate -----	2
20	39556 H	Presser Foot Hold Down Plate, for Styles 39500 FT, FU, GD, GL, GT-----	1
21		Presser Foot (See Page 35)-----	1
22	43139 A	Nut, for looper thread eyelet screw-----	2
23	22569 B	Screw, for looper thread eyelet mounting bracket ----	1
24	39568 D	Looper Thread Eyelet Mounting Bracket-----	1
25	39568 L	Upper Looper Thread Eyelet -----	1
26	39568 B	Lower Looper Thread Eyelet -----	1
27	376 A	Screw, for looper thread eyelets -----	2
28	39568 E	Auxiliary Looper Thread Eyelet -----	1
29	39568 R	Frame Looper Thread Eyelet -----	1
30	22569 D	Screw, for frame looper thread eyelet -----	1
31	22569 D	Screw, for frame needle thread eyelet -----	1
32	39563 H	Frame Needle Thread Eyelet-----	1
33	39592 AH	Nut, for thread tension post-----	3 or 4
34	22806 A	Screw, for tension post mounting bracket-----	1
35	22847 B	Screw, for tension post mounting bracket-----	1
36	39592 AM	Tension Post Bar, for Styles 39500 FS, FT, FU, GT, JP-----	1
	39592 AN	Tension Post Bar, for Styles 39500 GD, GL -----	1
37	39592 AL	Thread Tension Post -----	3 or 4
38	39592 AG-3	Tension Post Mounting Bracket, for Styles 39500 FS, FT, FU, GT, JP-----	1
	39592 AG-5	Tension Post Mounting Bracket, for Styles 39500 GD, GL -----	1
39	39592 AF	Tension Disc Felt-----	3 or 4
40	39592 AD	Thread Tension Disc -----	6 or 8
41	39592 AJ	Spring Shield -----	3 or 4
42	39592 AE-4	Looper Thread Tension Spring -----	2
	39592 AE-8	Needle Thread Tension Spring -----	1 or 2
43	39592 AK	Tension Spring Ferrule -----	3 or 4
44	39592 AA	Needle Tension Nut, green-----	1
	39592 AB	Upper Looper Tension Nut, blue-----	1
	39592 AC	Lower Looper Tension Nut, red-----	1
	39592 Z	Left Needle Tension Nut, yellow, for Styles 39500 GD, GL -----	1

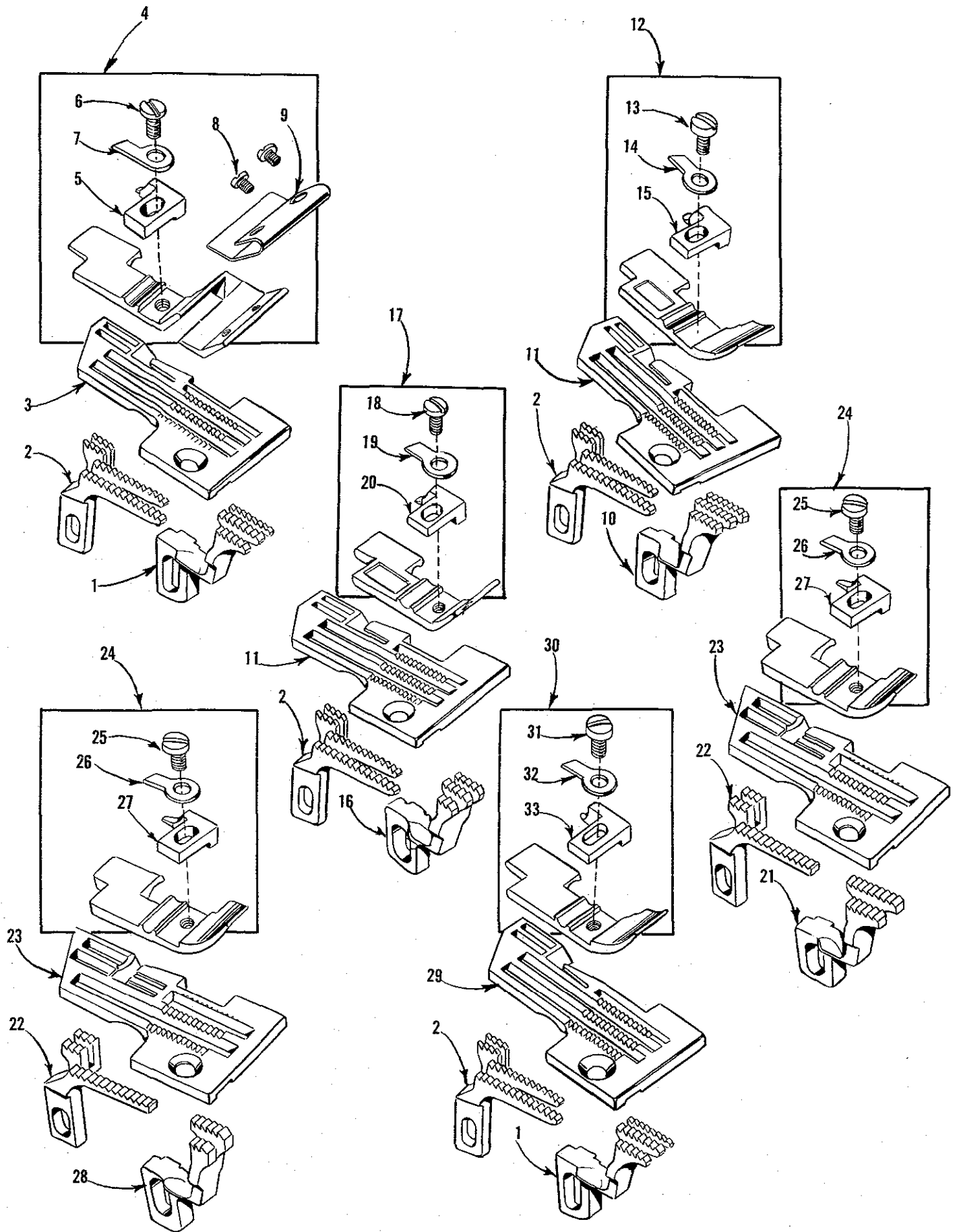

FEED DOGS, THROAT PLATES AND PRESSER FOOT

<u>Ref. No.</u>	<u>Part No.</u>	<u>Description</u>	<u>Amt. Req.</u>
1	39526 S	Differential Feed Dog, marked "M", 16 teeth per inch, for Styles 39500 FS, GT-----	1
2	39505 S	Main Feed Dog, marked "R", 16 teeth per inch, for Styles 39500 FS, FT, FU, GT-----	1
3	39524 S	Throat Plate, marked "AK", for Style 39500 FS ----	1
4	39520 S	Presser Foot, for Style 39500 FS -----	1
5	39597 S	Stitch Tongue, marked "EB" -----	1
6	22768 B	Screw -----	1
7	39530 G	Hinge Spring-----	1
8	91 A	Screw, for stripper blade -----	2
9	39530 F	Stripper Blade -----	1
10	39526 T	Differential Feed Dog, marked "N", 16 teeth per inch, for Style 39500 FT-----	1
11	39524 T	Throat Plate, marked "AL", for Styles 39500 FT, FU -----	1
12	39520 M	Presser Foot, for Style 39500 FT-----	1
13	J87 J	Screw -----	1
14	39530 G	Hinge Spring -----	1
15	39597 T	Stitch Tongue, marked "EC" -----	1
16	39526 U	Differential Feed Dog, marked "P" 16 teeth per inch, for Style 39500 FU -----	1
17	39520 T	Presser Foot, for Style 39500 FU-----	1
18	J87 J	Screw -----	1
19	39530 G	Hinge Spring-----	1
20	39597 T	Stitch Tongue, marked "EC" -----	1
21	39526 AD	Differential Feed Dog, marked "AJ", 16 teeth per inch, for Style 39500 GD -----	1
22	39505 AD	Main Feed Dog, marked "AH", 16 teeth per inch, for Styles 39500 GD, GL -----	1
23	39524 W	Throat Plate, marked "AN", for Styles 39500 GD, GL -----	1
24	39520 AD	Presser Foot, for Styles 39500 GD, GL -----	1
25	22768 B	Screw-----	1
26	39530	Hinge Spring-----	1
27	39597 AD	Stitch Tongue, marked "EL" -----	1
28	39526 AL	Differential Feed Dog, marked "AY", 16 teeth per inch, for Style 39500 GL -----	1
29	39524 AT	Throat Plate, marked "BF", for Style 39500 GT-----	1
30	39520 AT	Presser Foot, for Style 39500 GT-----	1
31	J87 J	Screw -----	1
32	39530 G	Hinge Spring-----	1
33	39597 AT	Stitch Tongue, marked "ET" -----	1
*	39526 B	Differential Feed Dog, 16 teeth per inch, for Style 39500 JP -----	1
*	39505 B	Main Feed Dog, marked "B" 16 teeth per inch, for Style 39500 JP-----	1
*	39524 C-3/32	Throat Plate, marked "AC-3/32", for Style 39500 JP, 3/32 inch seam width-----	1
*	39524 C-1/8	Throat Plate, marked "AC-1/8", for Style 39500 JP, 1/8 inch seam width -----	1
*	39520 B	Presser Foot, for Style 39500 JP -----	1
*	22738 B	Screw, for chain shield and chip guard -----	2
*	22768 B	Screw, for hinge spring and stitch tongue -----	1
*	39530	Hinge Spring -----	1
*	39530 C	Chain Shield -----	1
*	39530 P	Chip Guard -----	1
*	39597 A	Stitch Tongue, marked "DS"-----	1

* Parts used on Style 39500 JP, not shown on picture plate.

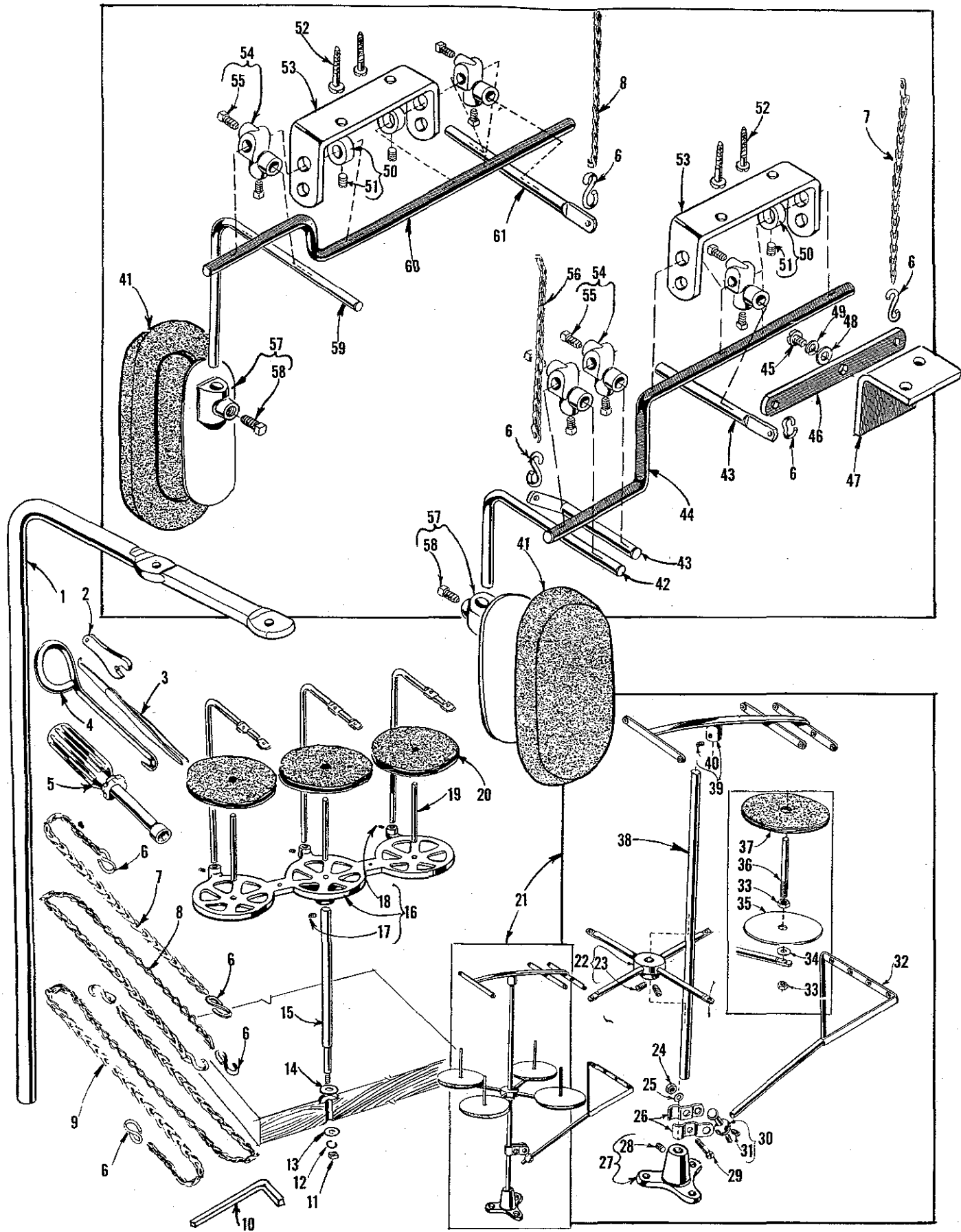

THREAD STANDS, ACCESSORIES AND MISCELLANEOUS TOOLS

Ref. No.	Part No.	Description	Amt. Req.
1	21113 F	Thread Stand Eyelet, for Styles 39500 FS, FT, FU, GT-----	3
2	116	Wrench, for 9/32 inch nut -----	1
3	660-240	Thread Tweezers -----	1
4	21227 BF	Feed Eccentric Extractor Hook-----	1
5	21388 AU	Socket Wrench, for 3/8 inch nuts holding feed eccentrics-----	1
6	660-264	"S" Hook, for chains -----	7
7	421 D-4	Presser Foot Lifter Chain, for all Styles except 39500 JP-----	1
8	421 D-5 3/4	Intermittent Differential Feed Control Chain, for all Styles except 39500 JP -----	1
9	421 D-34	Presser Foot Lifter Treadle Chain, for Style 39500 JP -----	1
10	WR56	Allen Wrench, 1/8 inch heptagon, for Styles 39500 GD, GL -----	1
11	651 A-16	Nut, for thread stand rod, for Styles 39500 FS, FT, FU, GT, JP -----	1
12	WA9 A	Lockwasher, for thread stand rod, for Styles 39500 FS, FT, FU, GT, JP -----	1
13	652 J-16	Washer, for thread stand rod, for Styles 39500 FS, FT, FU, GT, JP ---	1
14	652 J-24	Washer, for thread stand rod, for Styles 39500 FS, FT, FU, GT, JP ---	1
15	21104 AA	Thread Stand Rod, for Styles 39500 FS, FT, FU, GT, JP -----	1
16	21130 W-3	Cone Support, for Styles 39500 FS, FT, FU, GT, JP -----	1
17	22650 CE-6	Screw, for cone support -----	1
18	22650 CB-4	Screw, for thread stand eyelet -----	3
19	69 S	Spool Pin, for Styles 39500 FS, FT, FU, GT, JP -----	3
20	21104 V	Pad, for thread cone, for Styles 39500 FS, FT, FU, GT, JP -----	3
21	21101 H-4	Thread Stand Complete, for Styles 39500 GD, GL -----	1
22	21114 D-4	Spool Seat Support -----	1
23	22651 CD-5	Screw, for spool seat support -----	2
24	21104 H	Nut, for lead eyelet ball split socket -----	1
25	652-16	Washer, for lead eyelet ball split socket -----	1
26	21114 U	Lead Eyelet Ball Split Socket-----	2
27	21114 A	Thread Stand Base -----	1
28	22651 CD-4	Screw, for thread stand base-----	1
29	22810	Screw, for lead eyelet ball split socket-----	1
30	21114 T	Lead Eyelet Socket Ball -----	1
31	22651 CD-4	Screw, for lead eyelet socket ball -----	2
32	21114 S-4	Lead Eyelet -----	1
33	258 A	Nut, for spool pin-----	8
34	652-16	Washer, for spool seat disc-----	4
35	21114	Spool Seat Disc -----	4
36	21114 W	Spool Pin -----	4
37	21104 V	Pad, for thread cone -----	4
38	21104 B-20	Thread Stand Rod -----	1
39	21114 H-4	Eyelet Support -----	1
40	22651 CD-4	Screw, for eyelet support-----	1
41	660-168	Knee Press Pad, for Styles 39500 FS, FT, FU, GD, GL, GT-----	2
42	21663 A	Knee Press Plate Lever, for Styles 39500 FS, FT, FU, GD, GL, GT ---	1
43	21663 J	Knee Press Rod, for presser foot and pressure plate, for Styles 39500 FS, FT, FU, GD, GL, GT -----	2
44	21663 H	Knee Press Shaft, for presser foot and pressure plate, for Styles 39500 FS, FT, FU, GD, GL, GT-----	2
45	22557 A	Screw, for knee press lever, for Styles 39500 FS, FT, FU, GD, GL, GT-----	1
46	21662 AH	Knee Press Lever, for Styles 39500 FS, FT, FU, GD, GL, GT-----	1
47	21664 C	Bell Crank Bracket, for Styles 39500 FS, FT, FU, GD, GL, GT-----	1
48	43137 E	Washer, for bell crank bracket, for Styles 39500 FS, FT, FU, GD, GL GT-----	1
49	39536 AD	Spring Washer, for bell crank bracket, for Styles 39500 FS, FT, FU, GD, GL, GT-----	1
50	9271	Collar, for Styles 39500 FS, FT, FU, GD, GL, GT -----	3
51	98	Screw, for collar -----	1
52	SC-468	Wood Screw, for Styles 39500 FS, FT, FU, GD, GL, GT -----	6
53	21662	Knee Press Bracket, for Styles 39500 FS, FT, FU, GD, GL, GT -----	2
54	21665	Knee Press Rod Connection, for Styles 39500 FS, FT, FU, GD, GL, GT-----	5
55	69 FD	Screw, for knee press rod connection-----	2
56	421 D-8	Pressure Plate Chain, for Styles 39500 FS, FT, FU, GD, GL, GT-----	1
57	21664	Knee Press Plate, for Styles 39500 FS, FT, FU, GD, GL, GT -----	2
58	69 FD	Screw, for knee press plate -----	1
59	21663 A	Knee Press Plate Lever, for Styles 39500 FS, FT, FU, GD, GL, GT ---	1
60	21663 G	Knee Press Shaft, for differential feed adjustment, Styles 39500 FS, FT, FU, GD, GL, GT-----	1
61	21663 E	Lifter Length Rod, for Styles 39500 FS, FT, FU, GD, GL, GT -----	1
	28604 L	Container of Oil, for all Styles -----	1

NUMERICAL INDEX OF PARTS

<u>Part No.</u>	<u>Page No.</u>	<u>Part No.</u>	<u>Page No.</u>	<u>Part No.</u>	<u>Page No.</u>
WA9 A.....	37	12538.....	33	22653 B-12.....	23, 31
18	25	12865.....	33	22653 D-4.....	21
22 KH	29	12934 A.....	25	22657 D-12.....	21
28	23, 25, 27	14077.....	27, 31, 33	22704.....	33
30-92 Blk.....	23	21101 H-4.....	37	22726 L.....	27
40-46.....	23, 27	21104 H.....	37	22729 B.....	31
50-774 Blk.....	27	21104 B-20.....	37	22729 D.....	29
51-103 Blk.....	21	21104 V.....	37	22729 E.....	29
51-228 Blk.....	23	21104 AA.....	37	22738.....	31
WR56.....	37	21113 F.....	37	22738 B.....	35
CO67 E.....	23	21114.....	37	22743.....	21
CO67 F.....	27	21114 A.....	37	22747 B.....	23
69 S.....	37	21114 D-4.....	37	22768 B.....	35
69 FD.....	37	21114 H-4.....	37	22769 B.....	23
77.....	29	21114 S-4.....	37	22806 A.....	33
77 A.....	31	21114 T.....	37	22810.....	37
77 Q.....	23	21114 U.....	37	22847 B.....	33
87.....	25	21114 W.....	37	22892 B.....	31
87 U.....	27	21130 W-3.....	37	22894 C.....	29
J87 J.....	35	21227 BF.....	37	22894 D.....	23
88.....	33	21388 AU.....	37	22894 AD.....	21, 29
88 B.....	27	21662.....	37	28604 L.....	37
90.....	21	21662 AH.....	37	29126 DF.....	29
91 A.....	35	21663 A.....	37	29477 GW.....	21
93.....	27	21663 E.....	37	* 29477 JM.....	23
94.....	27	21663 G.....	37	29477 KE.....	23
95.....	23	21663 H.....	37	29480 DC.....	31
97.....	29	21663 J.....	37	39142 G.....	23
97 A.....	23	21664.....	37	39151.....	29
98.....	37	21664 C.....	37	39198 D.....	25
116.....	37	21665.....	37	39501 D.....	21
138.....	21	22503 F.....	29	39501 E.....	21
258.....	23, 27	22513.....	27	39501 K.....	21
258 A.....	37	22524.....	31	39501 DC.....	21
376 A.....	33	22528.....	27	39501 EC.....	21
421 D-4.....	37	22541.....	21	39505 B.....	35
421 D-5 3/4.....	37	22541 A.....	23	39505 S.....	35
421 D-8.....	37	22557 A.....	37	39505 AD.....	35
421 D-34.....	37	22557 E.....	25	39508 A.....	29
SC468.....	37	22561.....	31	† 39508 B.....	29
482 C.....	29	22562 A.....	21, 29	39520 B.....	35
604.....	31	22562 G.....	29	39520 M.....	35
605 A.....	31, 33	22565.....	21, 29	39520 S.....	35
627.....	33	22565 B.....	27	39520 T.....	35
651 A-16.....	37	22565 F.....	21, 23, 25	39520 AD.....	35
652-16.....	37	22565 H.....	29	39520 AT.....	35
652 J-16.....	37	22566 B.....	33	39521 C.....	23
652 J-24.....	37	22569.....	21, 27	39521 D.....	23
660-142.....	33	22569 A.....	21	39524 C-3/32.....	35
660-168.....	37	22569 B.....	21, 25, 33	39524 C-1/8.....	35
660-206.....	29	22569 C.....	21, 25, 27	39524 S.....	35
660-207.....	27		31	39524 T.....	35
660-240.....	37	22569 D.....	21, 33	39524 W.....	35
660-243.....	21	22569 G.....	27	39524 AT.....	35
660-264.....	37	22571 E.....	21	39525.....	31
660-268.....	23	22582.....	31	39525 A.....	31
666-94.....	23	22585 A.....	31	39525 F.....	31
666-255.....	29	22586 R.....	21	39525 G.....	31
667 B-12.....	23	22587 J.....	31	39525 M.....	31
667 D-8.....	21	22587 M.....	23	39526 B.....	35
907.....	31	22588 A.....	31	39526 S.....	35
1025 L.....	29	22596 E.....	27	39526 T.....	35
1280.....	29	22596 G.....	23	39526 U.....	35
6042 A.....	31	22598 E.....	33	39526 AD.....	35
7446 A.....	29	22650 CB-4.....	37	39526 AL.....	35
8372 A.....	25, 27	22650 CE-6.....	37	39530.....	35
9271.....	37	22651 CD-4.....	37	39530 C.....	35
		22651 CD-5.....	37	39530 F.....	35
				* 29477 JN.....	23
				† 39516.....	23

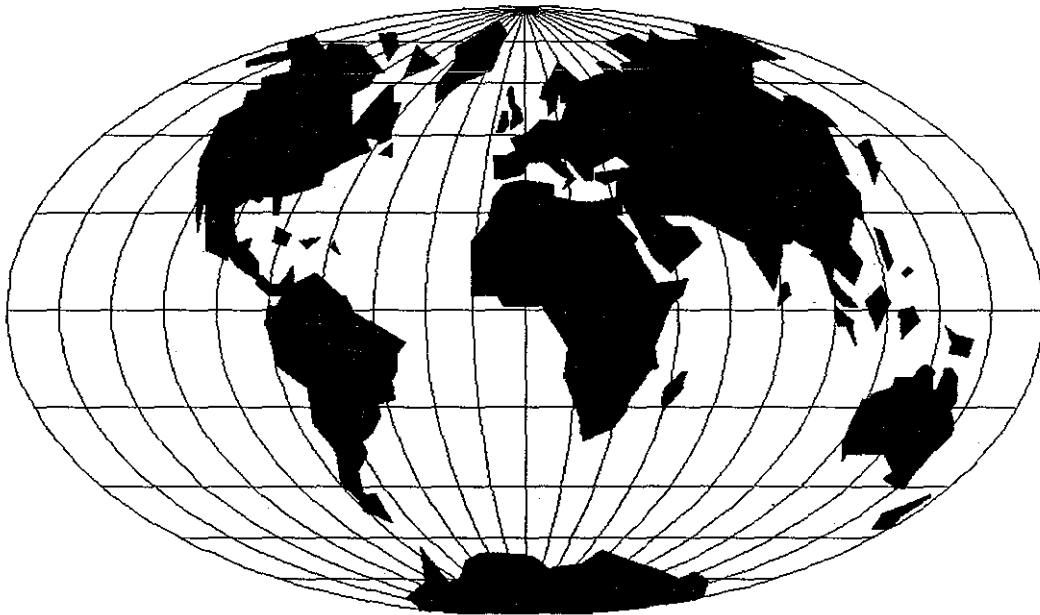

WORLDWIDE SALES AND SERVICE

Union Special Corporation maintains sales and service facilities throughout the world. These offices will aid you in the selection of the right sewing equipment for your particular operation. Union Special Corporation representatives and service technicians are factory trained and are able to serve your needs promptly and efficiently. Whatever your location, there is a qualified representative to serve you.

Corporate Office: One Union Special Plaza
Huntley, IL 60142
Phone: 847•669•5101
Fax: 847•669•1096

European Distribution Center: Union Special GmbH
Raiffeisenstrasse 3
D-71696 Möglingen, Germany
Tel: 49•07141•247•0
Fax: 49•7141•247•100

Brussels, Belgium
Charlotte, N.C.
El Paso, TX
Hong Kong, China
Huntley, IL
Leicester, England
Lille, France
Miami, FL
Milan, Italy
Möglingen, Germany
Montreal, Quebec
Osaka, Japan
Santa Fe Springs, CA

Other Representatives throughout
all parts of the world.



Union Special
INDUSTRIAL SEWING EQUIPMENT