

COVER PLATE, ARM SHAFT

カバー, 上軸関係

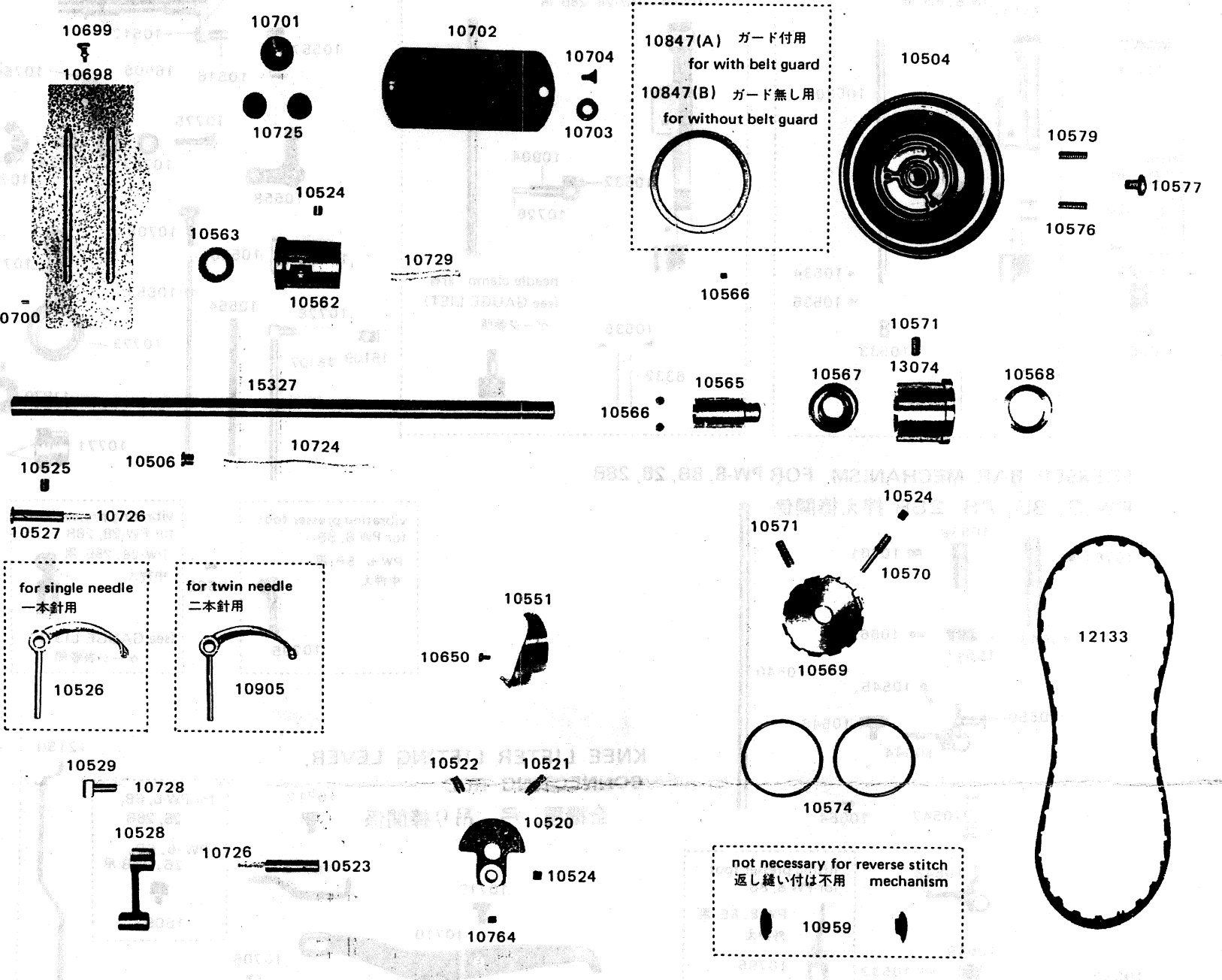

THREAD GUIDE, TENSION MECHANISM

糸掛, 調子板関係

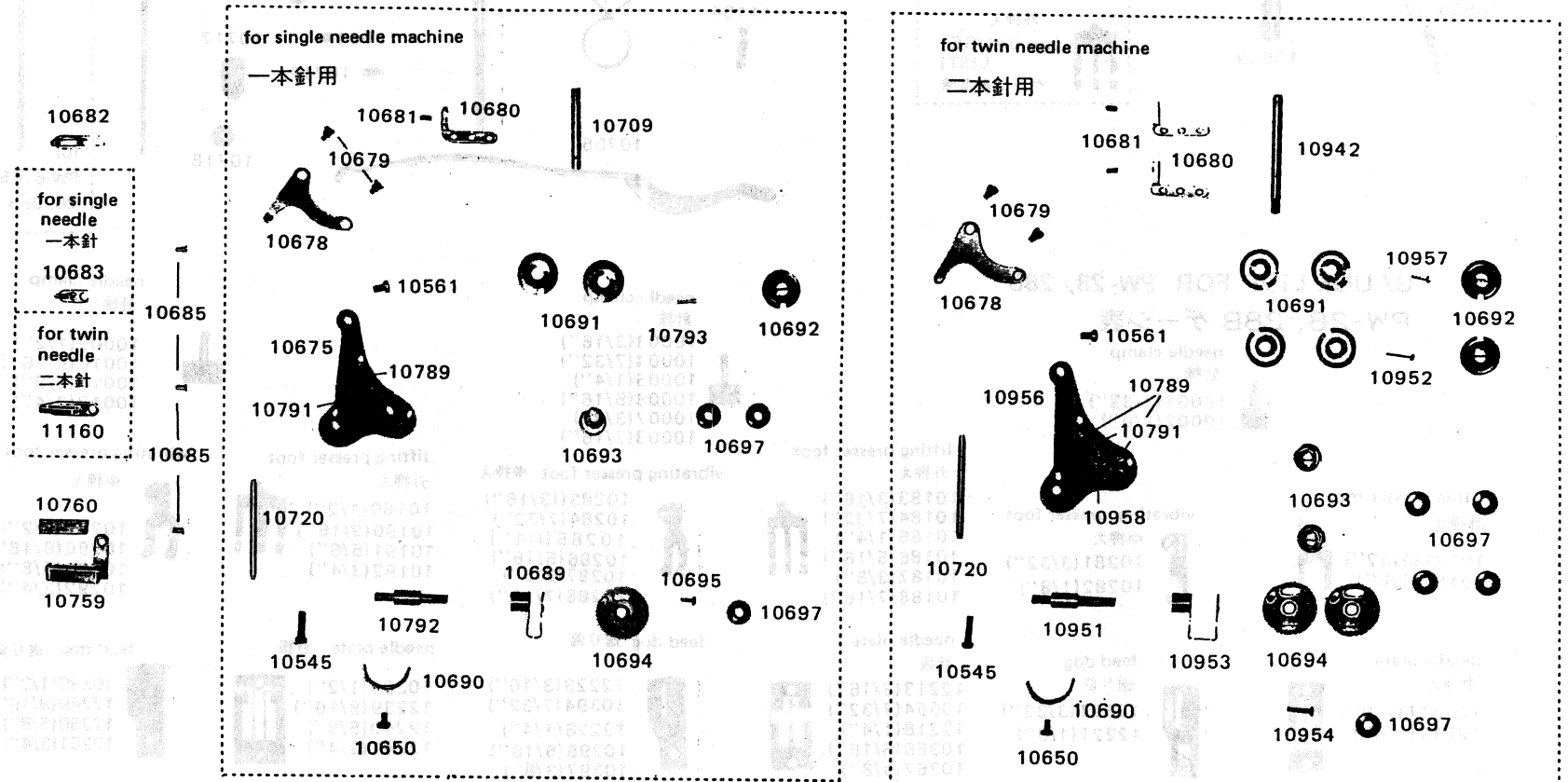

NEEDLE BAR MECHANISM FOR PW-8, 8B, 28, 28B

PW-8, 8B, 28, 28B 針棒関係

LIFTING ROCK SHAFT MECHANISM FOR PW-8, 8B, 28, 28B

PW-8, 8B, 28, 28B 横軸関係

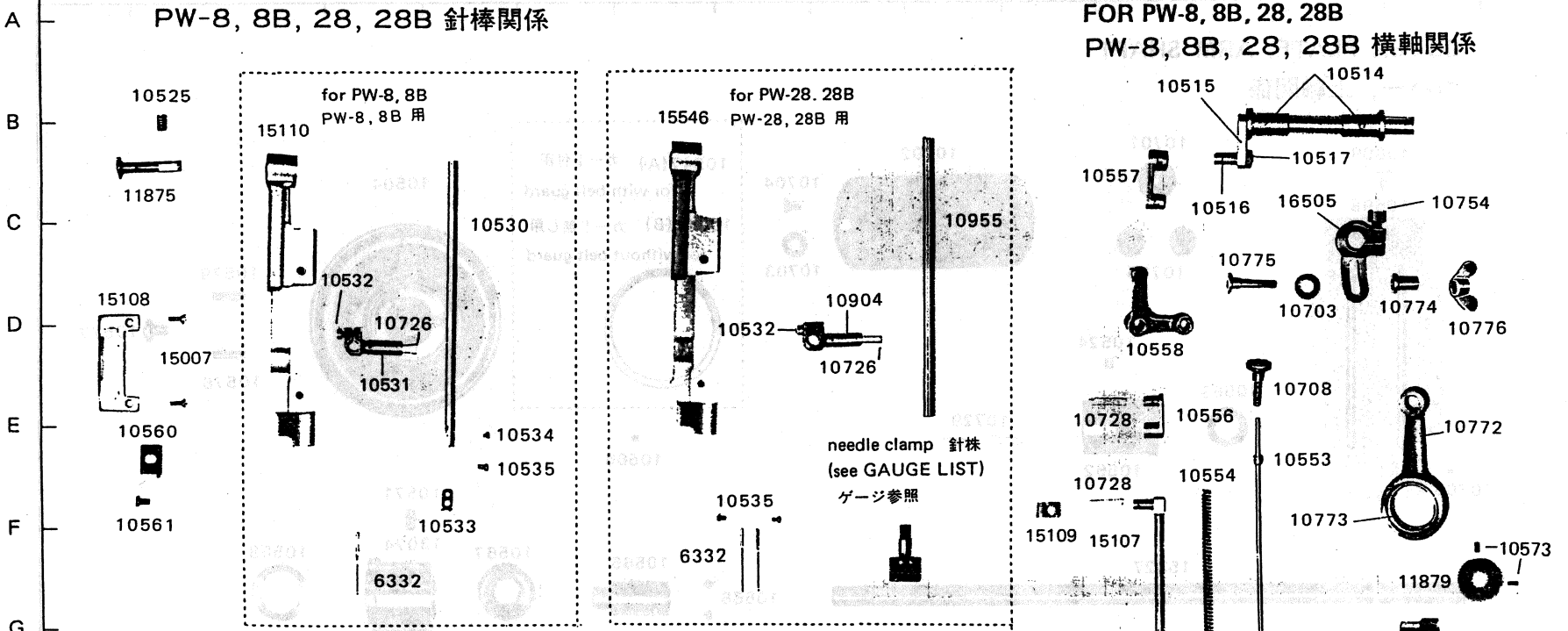

PRESSER BAR MECHANISM FOR PW-8, 8B, 28, 28B

PW-8, 8B, 28, 28B 押え棒関係

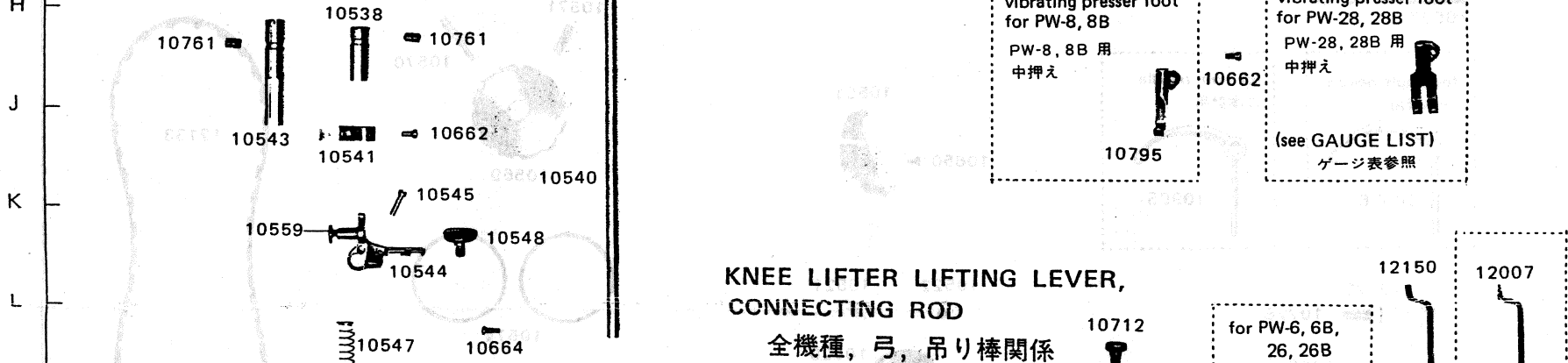

KNEE LIFTER LIFTING LEVER, CONNECTING ROD

全機種、弓、吊り棒関係

GAUGE LIST FOR PW-28, 28B

PW-28, 28B ゲージ表

<p>needle clamp 針株</p> <p>10001(3/32")</p> <p>10002(1/8")</p>	<p>needle clamp 針株</p> <p>10009(1/2")</p> <p>10010(9/16")</p> <p>10011(5/8")</p> <p>10012(3/4")</p>
<p>lifting presser foot 外押え</p> <p>10181(3/32")</p> <p>10182(1/8")</p>	<p>lifting presser foot 外押え</p> <p>10183(3/16")</p> <p>10184(7/32")</p> <p>10185(1/4")</p> <p>10186(5/16")</p> <p>10187(3/8")</p> <p>10188(7/16")</p>
<p>vibrating presser foot 中押え</p> <p>10281(3/32")</p> <p>10282(1/8")</p>	<p>vibrating presser foot 中押え</p> <p>10283(3/16")</p> <p>10284(7/32")</p> <p>10285(1/4")</p> <p>10286(5/16")</p> <p>10287(3/8")</p> <p>10288(7/16")</p>
<p>needle plate 針板</p> <p>10361(3/32")</p> <p>10362(1/8")</p>	<p>needle plate 針板</p> <p>10363(3/16")</p> <p>10364(7/32")</p> <p>10365(1/4")</p> <p>10366(5/16")</p> <p>10367(3/8")</p> <p>10368(7/16")</p>
<p>feed dog 送り歯</p> <p>10391(3/32")</p> <p>10392(1/8")</p>	<p>feed dog 送り歯</p> <p>10393(3/16")</p> <p>10394(7/32")</p> <p>10395(1/4")</p> <p>10396(5/16")</p> <p>10397(3/8")</p> <p>10398(7/16")</p>
<p>lifting presser foot 外押え</p> <p>10189(1/2")</p> <p>10190(9/16")</p> <p>10191(5/8")</p> <p>10192(3/4")</p>	<p>lifting presser foot 外押え</p> <p>10289(1/2")</p> <p>10290(9/16")</p> <p>10291(5/8")</p> <p>10292(3/4")</p>
<p>needle plate 針板</p> <p>10369(1/2")</p> <p>10370(9/16")</p> <p>10371(5/8")</p> <p>10372(3/4")</p>	<p>needle plate 針板</p> <p>10369(1/2")</p> <p>10370(9/16")</p> <p>10371(5/8")</p> <p>10372(3/4")</p>
<p>feed dog 送り歯</p> <p>10399(1/2")</p> <p>10400(9/16")</p> <p>10401(5/8")</p> <p>10402(3/4")</p>	<p>feed dog 送り歯</p> <p>10399(1/2")</p> <p>10400(9/16")</p> <p>10401(5/8")</p> <p>10402(3/4")</p>

LOWER SHAFT, FEED MECHANISM 送り機構, 下軸関係

A
B
C
D
E
F
G
H
J
K
L
M
N
O
P
Q
R
S
T
U
V

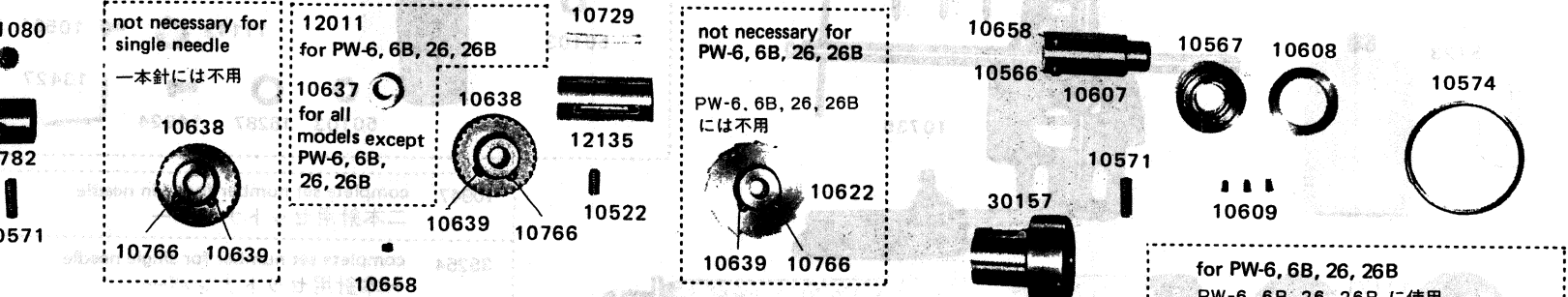
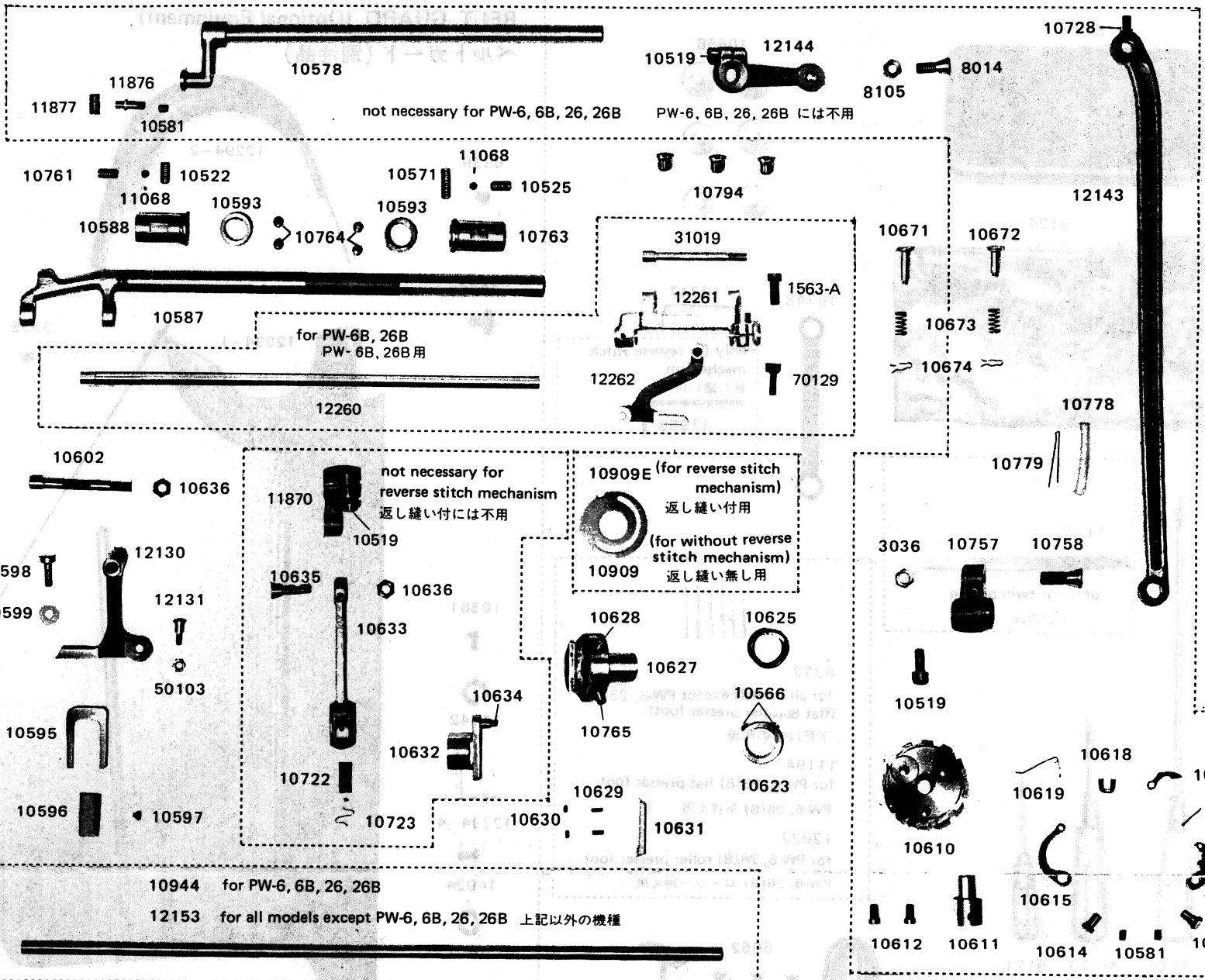

REVERSE STITCH MECHANISM 返し縫い関係

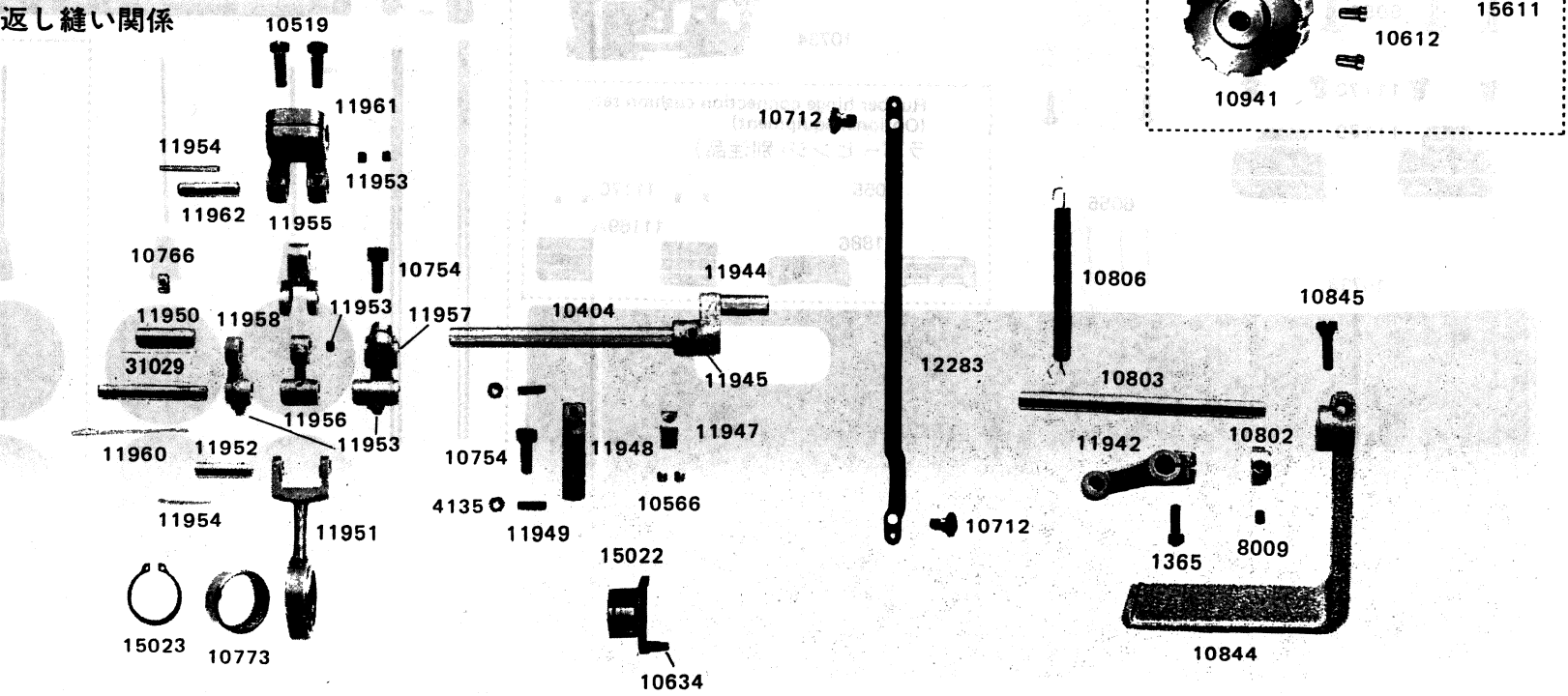

FEED DOG LEVER POST, HOOK SADDLE MECHANISM (SINGLE NEEDLE)

一本針用, 針板土台, カマ土台関係

for PW-7, 7B, 8, 8B

PW-7, 7B, 8, 8B 用

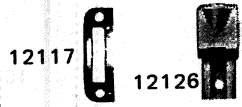

12117 needle plate 針板
12126 feed dog 送り歯

for PW-6, 6B (flat presser foot)

PW-6, 6B 平押え用



12003 needle plate 針板
12006 feed dog 送り歯

for PW-6, 6B (roller presser foot)

PW-6, 6B ロールー押え用

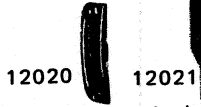

12020 needle plate 針板
12021 feed dog 送り歯

12105

12032

10656

12107

10766 10517



12121

12122

12137

10561

12127

6339

12128

12129

10703

13076

12119

12106

12114

12108

12111-N

12112-N

12435

10650

12116

12113

12132

10545

12136

12110

6031

12123

12110

12136

12120

11134

10767

12139

10650

12136

12110

HOOK カマ

Hook complete number
カマセット番号

12032.... for single need
12530.... for twin needit



13086 1



11124 2



10655-3



16291-3

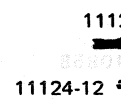

11124-12

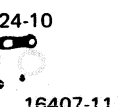

16407-11



12032, 5

FEED DOG LEVER POST, HOOK SADDLE MECHANISM (TWIN NEEDLE)

二本針用, 針板土台, カマ土台関係

for PW-27, 27B, 28, 28B

PW-27, 27B, 28, 28B 用

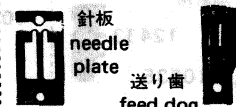

針板 needle plate
送り歯 feed dog
(see GAUGE LIST)
ゲージ表参照

for PW-26, 26B (flat presser foot)

PW-26, 26B 平押え用



針板 needle plate
送り歯 feed dog
(see GAUGE LIST)
ゲージ表参照

for PW-26, 26B (roller presser foot)

PW-26, 26B ロールー押え用

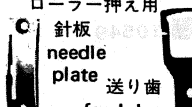

針板 needle plate
送り歯 feed dog
(see GAUGE LIST)
ゲージ表参照

10656

12105

12107

12530

12052-N

12051-N

12106

12115

12114

6339

12128

12129

10703

13076

12055

12435

12053-N

12054-N

12113

12108

10650

12116

10561

12137

10561

12136

12056

12120

12530

12136

12110

11134

10767

common use for single needle and twin needle
一本針・二本針共通

12138

6031

12231(1/32"-1/8")

12232(3/16"-3/8")

12132(1/2" - 3/4")

12140

10561

10561

NEEDLE BAR MECHANISM FOR PW-7, 7B, 27, 27B
PW-7, 7B, 27, 27B 針棒関係

NEEDLE BAR MECHANISM FOR PW-6, 6B, 26, 26B
PW-6, 6B, 26, 26B 針棒関係

A	B	C	D	E	F	G	H	J	K	L	M	N	O	P	Q	R	S	T	U	V	for single needle 一本針用 10859 10534 10860 6332	for twin needle 二本針用 10992 needle clamp 針株 ゲージ表参照 (see GAUGE LIST) 10535 6332	12005 10571 10856 10532 10726 10571 10539 needle set screw for twin needle 二本針用針止 12076.....for 12067 12067用 10535 (right 右) 15823 (left 左)for 15819 15819 用	for single needle 一本針用 10859 10534 10535 10860 11194 (for flat presser foot) 平押え用 12022 (for roller presser foot) ローラー押え用	for twin needle 二本針用 10992 needle clamp 針株 (see GAUGE LIST) ゲージ表参照 11194 (for flat presser foot) 平押え用 12022 (for roller presser foot) ローラー押え用
																					10525 10537 10855 10856 10726 10532 10560 10561				

PRESSER BAR MECHANISM FOR PW-6, 6B, 7, 7B, 26, 26B, 27, 27B

PW-6, 6B, 7, 7B, 26, 26B, 27, 27B 押え棒関係

flat presser foot
平押え

roller presser foot
ローラー押え

A	B	C	D	E	F	G	H	J	K	L	M	N	O	P	Q	R	S	T	U	V	10543 10761 10548 10660 10659 10541 10662 10858 10857 10549 10532 10761 15836	10540 10664 presser foot for single needle 押え金 一本針用 13105 for twin needle 二本針用 (see GAUGE LIST) ゲージ表参照	12432 12440 12433 12442 12441 12433 10535 12442 12072 roller holder shim ホルダー受板 12737(1/32") 12729(3/64") 12738(1/16") 12730(5/64") 12731(3/32") roller presser needle guard 補助押え 12523(5/64") 15844(3/32") 12522(1/16") 12521(3/64") 12520(1/32")	15833 15832 15834 15829 15826 Set No. 15829C セットNo. 15829C
																					10538 10761 10541 10662 10858 10549 10532 10761 15836			

GAUGE LIST FOR PW-27, 27B

PW-27, 27B ゲージ表

GAUGE LIST FOR PW-26, 26B

**(FLAT PRESSER FOOT)
PW-26, 26B 平押え用ゲージ表**

GAUGE LIST FOR PW-26, 26B

**(ROLLER PRESSER FOOT)
PW-26, 26B,
ローラー押え用ゲージ表**

A	B	C	D	E	F	G	H	J	K	L	M	N	O	P	Q	R	S	T	U	V	common use for PW-27(B), 26(B) (flat presser foot) PW-27(B), 26(B) 共通ゲージ (平押え用) presser foot 押え金 needle clamp 針株 11210(1/16") 11200(1/16") 11211(3/32") 11201(3/32") 11212(1/8") 11202(1/8") 11213(3/16") 11203(3/16") 10164(7/32") 10024(7/32") 11214(1/4") 11204(1/4") 11215(5/16") 11205(5/16") 11216(3/8") 11206(3/8") 10168(7/16") 10028(7/16") 10169(1/2") 10029(1/2") 10170(9/16") 10030(9/16") 10171(5/8") 10031(5/8") 10172(3/4") 10032(3/4")	needle plate 針板 feed dog 送り歯 needle plate 針板 feed dog 送り歯 needle clamp 針株 12067(1/32" - 5/64") 15819(3/32") needle plate 針板 12058(1/32" - 3/64") 12060(1/16") 12061(5/64") 12062(3/32") feed dog 送り歯 12057(1/32"-1/16") 12064(5/64"-3/32")
																					10360(1/16") 10390(1/16") 10361(3/32") 10391(3/32") 12211(1/8") 12221(1/8") 12213(3/16") 12223(3/16") 10364(7/32") 10394(7/32") 12216(1/4") 12226(1/4") 10366(5/16") 10396(5/16") 10367(3/8") 10397(3/8") 10368(7/16") 10398(7/16") 10369(1/2") 10399(1/2") 12239(9/16") 12249(9/16") 12240(5/8") 12250(5/8") 12241(3/4") 12251(3/4")	

ACCESSORIES

付属品

8132

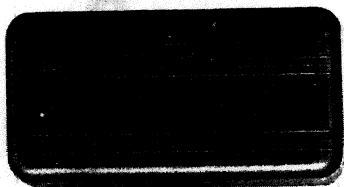

10656



BELT GUARD (Optional Equipment)

ベルトガード(別注品)

6339

12294-2

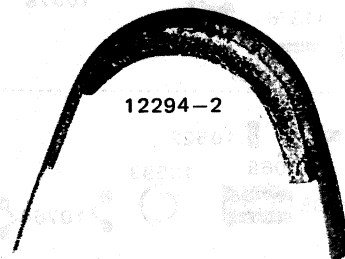

8124



10748

10747



only for reverse stitch mechanism
返し縫い付のみ

11969

10559



12294-1

6339

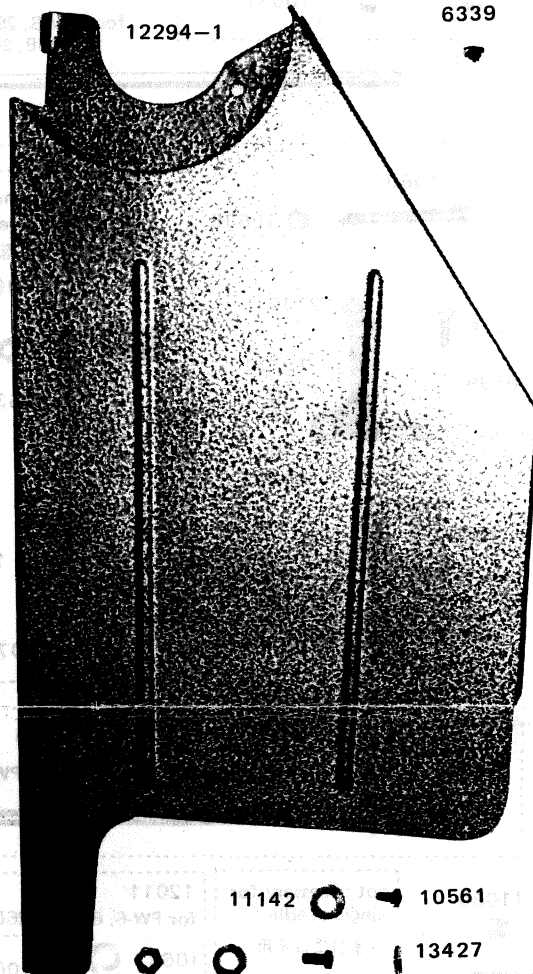

11196



only for twin needle
二本針のみ

6332

for all models except PW-6, 26(B)
(flat & roller presser foot)
下記以外の機種

11194

for PW-6, 26(B) flat presser foot
PW-6, 26(B) 平押え用

12022

for PW-6, 26(B) roller presser foot
PW-6, 26(B) ローラー押え用

10561



11142



12294-4



14024



16287



50103



11142



10561

50103



16287



14024



13427



10947 complete set number for twin needle
二本針用セットナンバー

35254 complete set number for single needle
一本針用セットナンバー

8118

8120

8121

8123

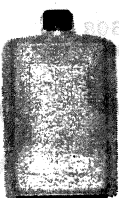

6052

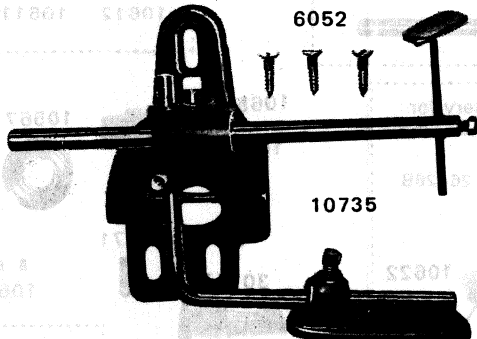

10735

11171



6052



11170



11169



6055

10733

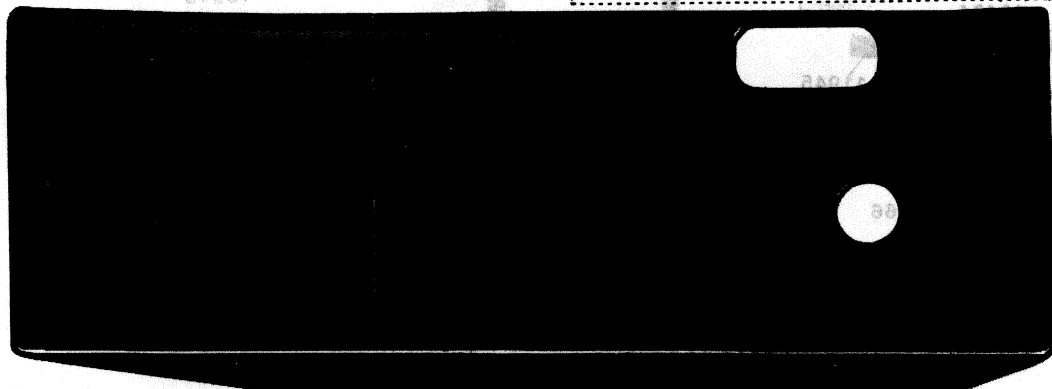

Rubber hinge connection cushion set
(Optional equipment)
ラバーヒンジ(別注品)

6055

11170

11886

11169A

