



*Union Special*  
INDUSTRIAL SEWING EQUIPMENT

**STYLES**

**ADJUSTING INSTRUCTIONS AND  
ILLUSTRATED PARTS LIST**

---

---

**31100E**

**31100K**

**31100L**

**OUTSTANDING TWO NEEDLE CYLINDER  
BED SEAM COVERING MACHINES**

---

---

**CATALOG  
NO. 247**

**FIRST  
EDITION**



**FIRST EDITION**  
**© 1965**

**PRINTED 1996 IN USA**

**INFORMATION SUBJECT TO CHANGE WITHOUT NOTICE**

**© UNION SPECIAL CORPORATION ALL RIGHTS RESERVED IN ALL COUNTRIES.**



Spare-parts catalog and adjusting instruction for  
UNION-SPECIAL-sewing-machines Classes 31100 E, K, L.

STYLES OF MACHINES

31100 E-8 High Speed, Streamlined Sidewheel, Cylinder Bed Machines,  
31100 E-12 two Needles Abreast, Automatic Lubrication System, Cylinder  
31100 E-16 Circumference 6 3/16 Inches = 157 mm. Plain Feed, Teeth  
Cut 16 per Inch.

The Machines are fitted with Needle Bearings, Light  
Weight Needle and Presser Bar and Oil-Siphon.

The 8 and 12 gauge machines are equipped with a retainer  
needle to produce a proper elastic stitch on difficult  
to handle materials and threads.

For the second part of the two-operation covered seam  
on knitted undergarments and similar articles.

31100 K-12 Same as 31100 E-12 and -16 but with differential feed 2:1,  
31100 K-16 teeth cut 10 per inch.

31100 L-12 Same as 31100 K-12 and -16 but teeth cut 16 per inch.  
31100 L-16

Stitch type and seam specification: 406/SSh-2

<u>Needle distances:</u>	8	12	16	gauges
	3,17	4,76	6,35	mm

Length of stitch: Plain feed machine 1-5 mm = 5-25 stitches per inch  
Differential feed machine 1,2 - 3,6 mm = 7-21 stitches  
per inch.

Maximum speed: Plain feed machine 4800 R.P.M  
Differential feed machine 4500 R.P.M

Handwheel-Ø : 63 mm = 2 1/2 inches

Needle type: 121 GBS-032, available sizes: 027, 032, 036, 040, 044.

Retainer needle: (only for 8 and 12 ga) 31111-027

## A D J U S T I N G   I N S T R U C T I O N S

### Styles 31100 E, K, L

Operating direction of the machine is clockwise.

Oiling and threading diagram	Drawing No. 20549 Q
Drilling template for sewing table plate	Drawing No. 20548 Q
Assembling instructions for thread stand	Drawing No. 15384 M

#### Looper Gauges

8-gauge machines	=	Gauge No. 21225	-	7/32"	(5,56 mm)
12-gauge machines	=	Gauge No. 21225	-	3/16"	(4,76 mm)
16-gauge machines	=	Gauge No. 21225	-	5/32"	(3,97 mm)

#### Needle Lever Stud

Check the location of the needle lever stud with respect to its oil groove. The head of the needle lever stud is marked with an arrow and the word "up". The stud is set correctly when the arrow points vertically up. Also, check the position of the oil tube inside the arm casting which lubricates the needle lever stud. Make sure it is tilted downwards and its delivery end contacts the wall of the bed casting just above the notch in the needle lever thrust collar. Do not allow the oil tube to rest on the needle lever.

#### Lubrication

Fill the oil reservoir (drawing No. 20549 Q) as the oil has been drained before shipment. Use "Mobil DTE Oil 'Medium'" (straight mineral oil, Saybolt viscosity of 200 to 250 seconds at 100° F) or another oil with same specifications.

When filling the oil reservoir and before starting operation be sure that the oil level is between the two red lines of the oil gauge (CAUTION! The oil level should never be above the upper red line). Lubrication is automatic, including the cylinder arm. For draining the oil there is a plug screw in the base plate located below the looper thread take-up (drawing No. 20549 Q). Normally, the oil should be drained completely and renewed once a year. Also, take off the cylinder arm cover and remove the lint which may have found its way into the cylinder. Seal the cylinder arm cover and tighten the three cover screws.

### Setting the Needles

Put in two new needles Type 121 GBS (128 GAS needles can also be used). The 8- and 12-gauge machines have a retainer needle Type 31111-027. Insert the needles into the needle head as far as they will go with long grooves of the 121 GBS needles toward the operator. The retainer can be set without any attention because there is no eye or groove. The needles should be in the center of the needle holes in the throat plate.

### Looper Adjustment

Insert the looper into the looper holder and tighten screw against the flat on shank. With the needle bar at the bottom of its travel the looper gauge (distance from the center of the left needle to the looper point) must be adjusted according to the following table:

	<u>Looper Gauge</u>	<u>Gauge No.</u>
8 gauge machines	7/32" = 5,56 mm	21225 - 7/32"
12 gauge machines	3/16" = 4,76 mm	21225 - 3/16"
16 gauge machines	5/32" = 3,97 mm	21225 - 5/32"

To adjust the looper gauge loosen the hexagonal screw No. 22792 C by using socket wrench No. G 21388 AE and turn the looper holder until the looper point has the correct gauge to the left needle. Tighten the hexagonal screw.

### Setting Looper to Needle and Looper Avoid Motion

When the looper moves to the right the looper point should pass the rear of the left needle as closely as possible without contacting (.002 inch clearance). This adjustment is made by

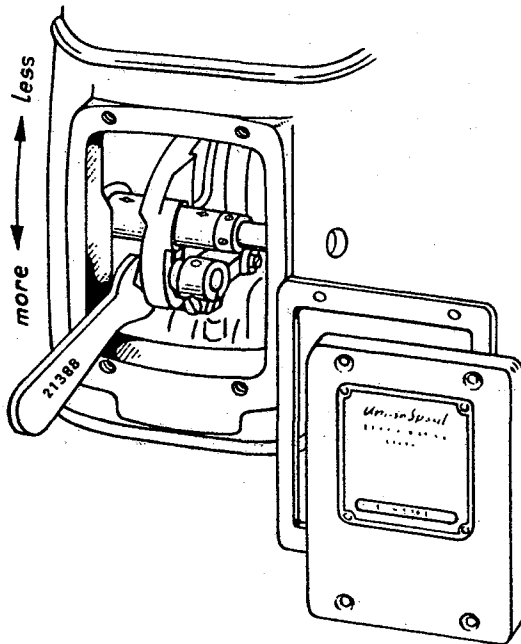

loosening the hexagonal screw No. 22792 C, using socket wrench No. G 21388 AE and moving the looper holder axially. Tighten hexagonal screw and check the looper gauge. If it is necessary to have more or less looper avoid motion, remove cover plate No. 31182 N at the rear of the machine (CAUTION! Handle cork gasket with care). Now, the looper avoid segment is accessible for avoid motion adjustment. Loosen the nut with wrench No. 21388 AE (see sketch). To increase the avoid motion the connection link must be moved downwards and to reduce upwards. Tighten the nut and replace the cover plate. No. 31182 N with the cork gasket.

### Looper Needle Guard

The looper needle guard is set correctly when it moves to the right and barely touches the left needle and a space of about .002 inch (0,04 - 0,05 mm) remains between looper point and the rear of the left needle.

### Height of the Needle Bar

Set the needle bar so that the top of the right needle eye is  $\frac{3}{64}$ " (1,2 mm) below the looper point when the looper is moving to the right and its point is even with the right side of the right needle. To adjust the needle bar height loosen needle bar clamp screw No. 22562 A.

### Needle Bar Travel Adjustment

The needle bar travel of the machine is adjusted at the factory for  $1 \frac{7}{32}$ " (31 mm). Should it be necessary to increase the needle bar travel for heavy weight fabrics or to reduce it for

light weight material, it can be adjusted from  $1 \frac{9}{32}$ " (32,5 mm) to  $1 \frac{5}{32}$ " (29,5 mm). To change the needle bar travel remove cover No. 52882 AD and loosen clamp screw No. BP 108 on the needle lever by using wrench No. 21388. To increase the needle bar travel, the ball stud should be moved toward the needle bar. Moving it in the other direction decreases the needle bar travel. Gauge No. G 21227 E can be used advantageously for setting the needle bar travel correctly (see sketch). Tighten the clamp screw.

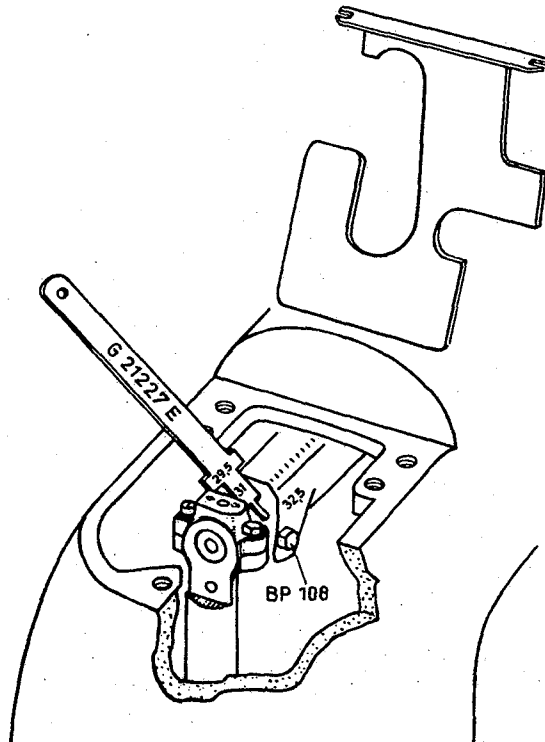



### Adjusting the Stitch Length of the Non-Differential Feed Machine

The mechanism for setting the stitch length is located in the cylinder (see sketch). This mechanism is accessible after removing plug screw No. 22539 D which is located above and to the rear of the handwheel. Loosen the ball screw No. 31133 B by turning left

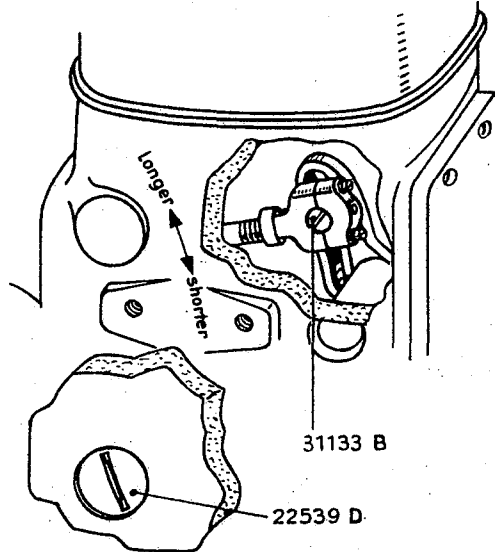

and move it in the feeding segment. Moving downwards results in a shorter stitch length and upwards in a longer one. When setting the longest stitch length (approximately 6 S.P.I.) be sure that the feed dog has a minimum clearance of about .020" (0,5 mm) at the front and rear of the throat plate slots. Tighten ball screw and replace plug screw No. 22539 D.

### Setting the Differential Feeding

On the handwheel side there is a lever with a knurled screw which rests on a graduated curved plate for changing the differential feeding. The graduated plate has no definite measurements, the marks are only for comparison.

Turning the knurled screw to the left increases the amount of differential action and turning this screw to the right decreases the differential feeding. The ratio can be changed from non-differential to 2:1 differential action.

**CAUTION!** Both feed dogs are set at the factory so that they do not contact each other. If it is necessary for a special fabric to make the distance between the feed dogs smaller, use the following directions:

Loosen the three screws of cylinder arm cover. Then take off cylinder arm cover carefully (do not damage cork gasket) by using a screw driver at the side of the looper thread groove.

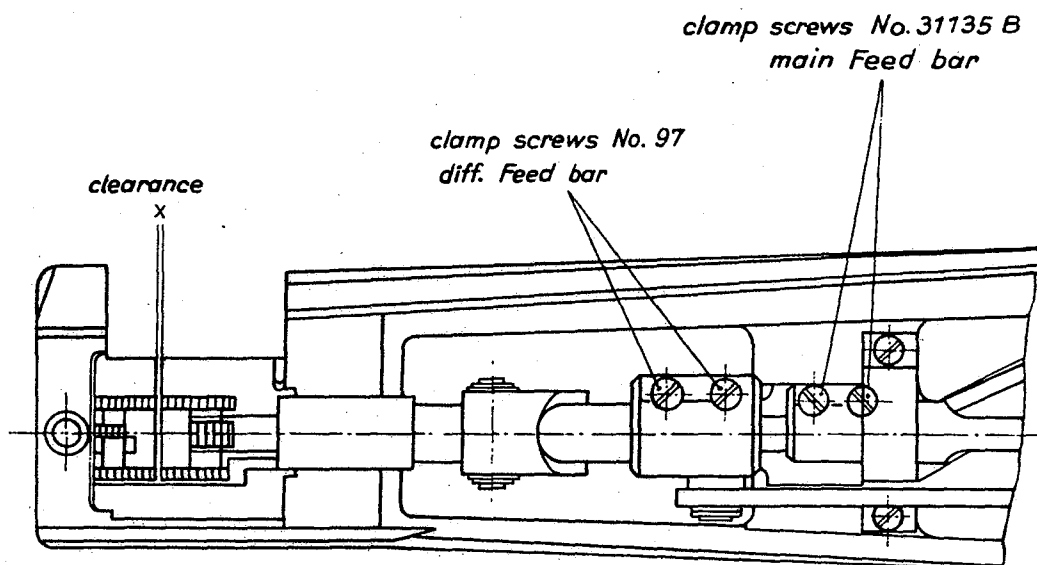

Now the feed bars are accessible and adjustable by loosening clamp screws No. 31135 B and No. 97 (see sketch). After finishing adjustment tighten clamp screws and replace cylinder arm cover with gasket and rubber sealing cord. Damaged gaskets or rubber sealing cords should be replaced by new ones.

#### Height of Feed Dogs

The feed dogs are set correctly when the tips of the teeth project  $3/64$ " above the throat plate when the feed dogs are in the highest position. The height adjustment is made on the non-differential machine 31100 E by loosening set screws No. 22560 B and turning the eccentric stud No. 31139 A. After this adjustment tighten set screws.

In differential feed machines 31100 K and L the eccentric stud No. 31139 A must be in the lowest position. Each feed dog may be set independently of each other in the feed bar.

#### Presser Foot

The presser foot must set flat on the throat plate and in line with the needles. Be sure the hinge point and the yielding sections move freely.

With the presser foot raised the stop collar on the presser bar is set correctly when the needle shank or the needle bar head does not contact the presser foot when the needle bar is at the bottom of its stroke.

### Pressure on the Presser Foot

The pressure regulating screw is the knurled screw located on top of the machine arm next to the needle bar. Set the pressure of the presser foot spring so that there is just enough pressure for proper feeding of the fabric.

### Threading of the Machine

Thread the machine according to diagram No. 20549 Q and start sewing.

### Looper Thread Take-Up

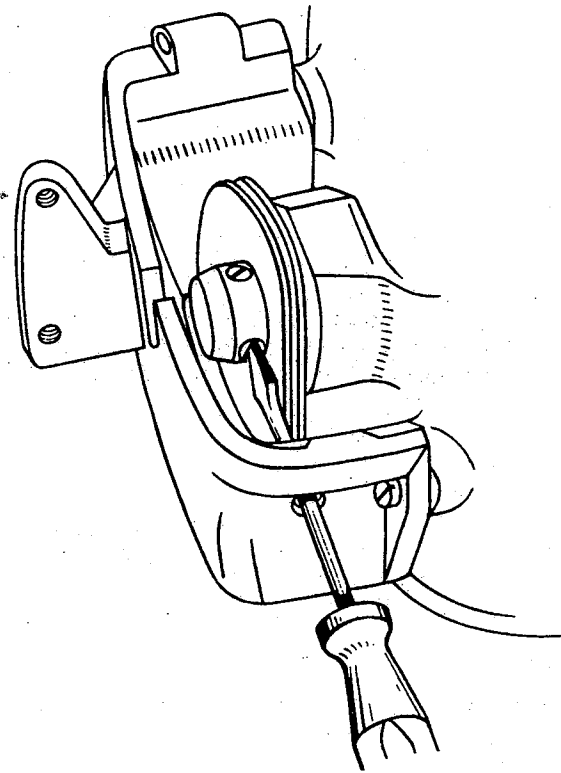

The double disc take-up must be set into the middle of cast-off plate slot. It is located at the left side of the crank shaft and is adjustable with two set screws (see sketch). When the needles move downwards and the looper begins to travel from extreme right to left, the take-up must contact the looper thread so that all slack is removed. The looper thread should cast off the high point of the take-up when the looper with its eye is at the right threaded needle.

### Thread Guides on the Cast-Off Plate

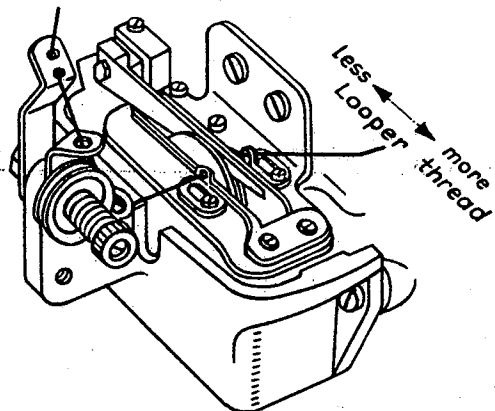

At the right and left side of the double disc take-up on the cast-off plate there are adjustable thread eyelets. These eyelets must be set as close as possible to the double disc take-up. To adjust these eyelets towards the operator results in more looper thread in the system and moving them in the opposite direction, less looper thread will be drawn.

#### Looper Thread Control

The looper thread retainer No. 31104 which is mounted on the cast-off plate support can be moved up and down, and from side to side. It should be set laterally so that it is midway between the two discs of the take-up. The height of the retainer affects the control of the looper thread as the looper moves to the right. More looper thread is given to the stitch when the retainer is raised. However, if the retainer is raised too high, the looper thread may be wiped under the looper causing triangle skips or pulled down stitches. This can be checked by observing the action of the looper thread as the looper moves to the right.

#### Thread Tension

The tension on the needle threads should only be sufficient to produce uniform stitches on the bottom side of the fabric. The looper thread tension should be approximately one fourth of the tension which is applied to each needle thread.

#### Needle Thread Guide and Take-Up Wire

The needle thread guide No. G 52758 is set in a straight line with the thread of the lower tension (see drawing No. 20549 Q). If it is necessary to have more needle thread turn the guide upwards. Set the take-up wire so that the thread of the left needle just contacts the wire when the loop of the left needle is released from the looper.

#### Seam Test

Unravel the stitch and check thread to see if it is chafed from sharp feed dog teeth, if so, the feed dog teeth may be stoned slightly to remove the sharp edges.

#### Needle Thread Nipper

The needle thread nipper is not assembled at the factory. It should be used for heavy threads or for threads which form a small needle loop.

Diese Fläche muß waagrecht stehen, wenn Nadelhebel in tiefster Stellung.  
THIS SURFACE MUST BE HORIZONTAL WHEN NEEDLE LEVER IS IN ITS LOWEST POSITION.

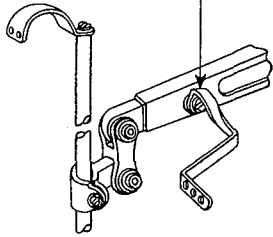

Beachte:  
Maschine wird ohne Öl geliefert. Vor Inbetriebnahme Behälter unbedingt mit Öl füllen.  
Geeignetes Öl:  
Gargoyle DTE Öl medium. Unter normalen Betriebsbedingungen Ölwechsel 1\* pro Jahr.

CAUTION:  
FILL ALL OIL RESERVOIRS BEFORE STARTING. MACHINE HAS BEEN DRAINED BEFORE SHIPPING.  
USE AN S. A. E. 10W STRAIGHT MINERAL OIL. ON NORMAL OPERATING CONDITIONS CHANGE THE OIL ONCE A YEAR.

Der Nadelhebelbolzen muß so eingebaut sein, daß der Pfeil nach oben zeigt.  
THE NEEDLE LEVER STUD MUST BE ASSEMBLED SO.

Greiferfaden  
LOOPER THREAD

Hauptölbehälter hier füllen.  
FILL MAIN RESERVOIR HERE.

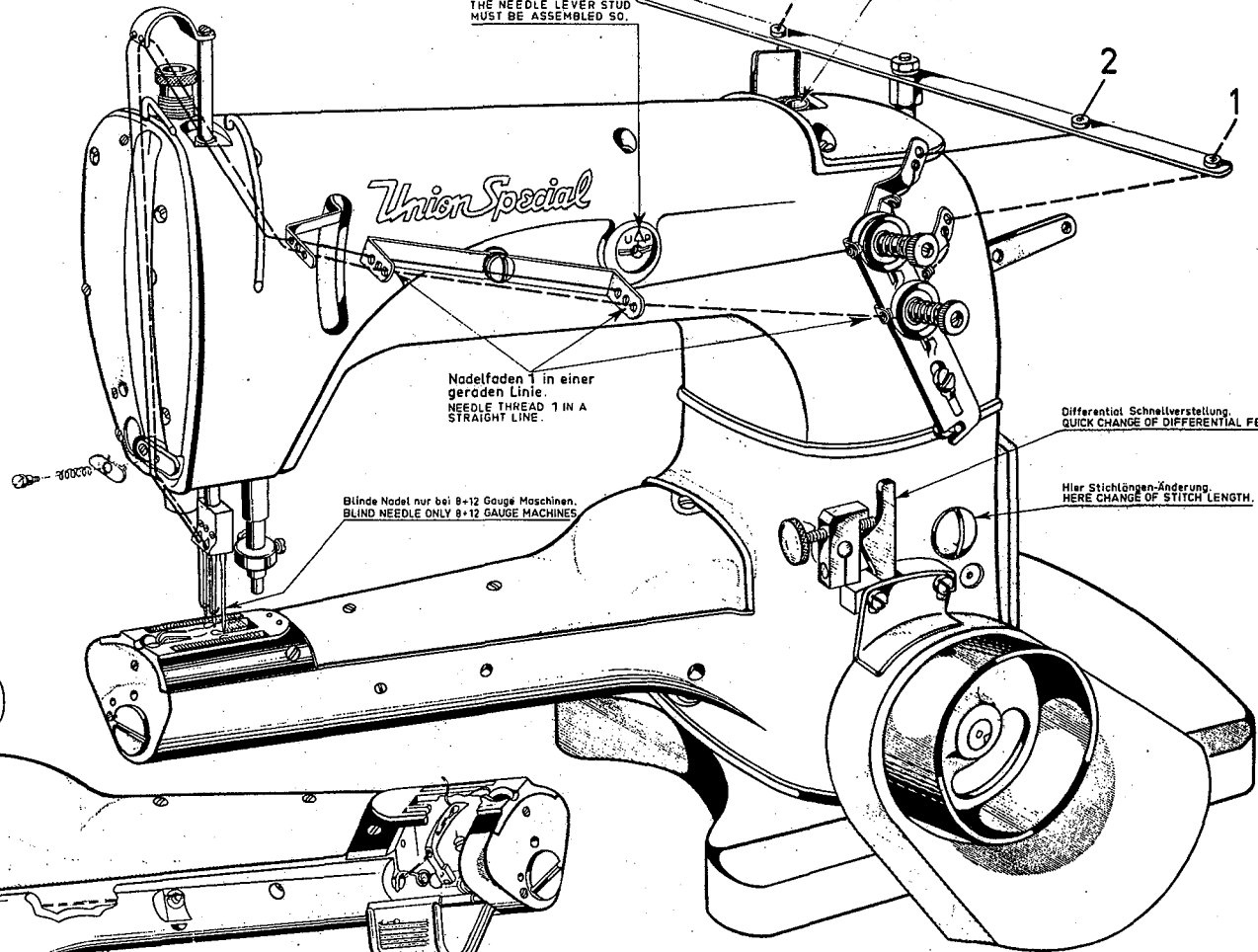

Nadelfaden 1 in einer geraden Linie.  
NEEDLE THREAD 1 IN A STRAIGHT LINE.

Blinde Nadel nur bei 8+12 Gauge Maschinen.  
BLIND NEEDLE ONLY 8+12 GAUGE MACHINES

Differential Schnellverstellung.  
QUICK CHANGE OF DIFFERENTIAL FEED.

Hier Stichlängen-Änderung.  
HERE CHANGE OF STITCH LENGTH.

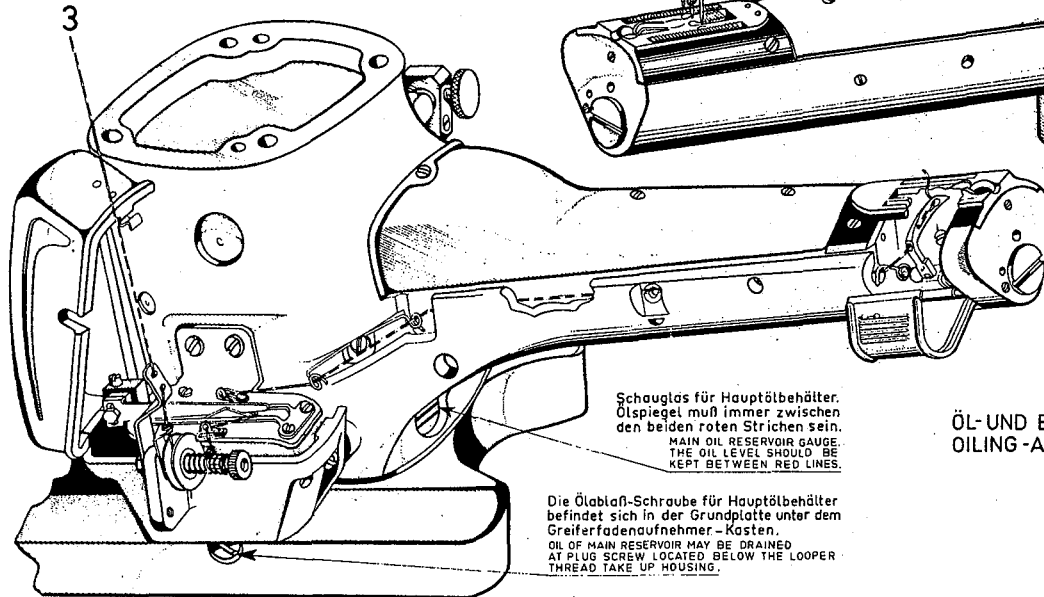

Schauglas für Hauptölbehälter.  
Ölspiegel muß immer zwischen den beiden roten Strichen sein.  
MAIN OIL RESERVOIR GAUGE.  
THE OIL LEVEL SHOULD BE KEPT BETWEEN RED LINES.

Die Ölablaß-Schraube für Hauptölbehälter befindet sich in der Grundplatte unter dem Greiferfadenaufnehmer-Kasten.  
OIL OF MAIN RESERVOIR MAY BE DRAINED AT PLUG SCREW LOCATED BELOW THE LOOPER THREAD TAKE UP HOUSING.

ÖL-UND EINFÄDELANLEITUNG FÜR MASCHINEN DER KLASSE 31100  
OILING-AND THREADING DIAGRAM FOR MACHINES CLASS 31100

Zchg. Nr. 20549-Q  
DRG No.

23.3.62.  
10-11-1962/107 20.2.62

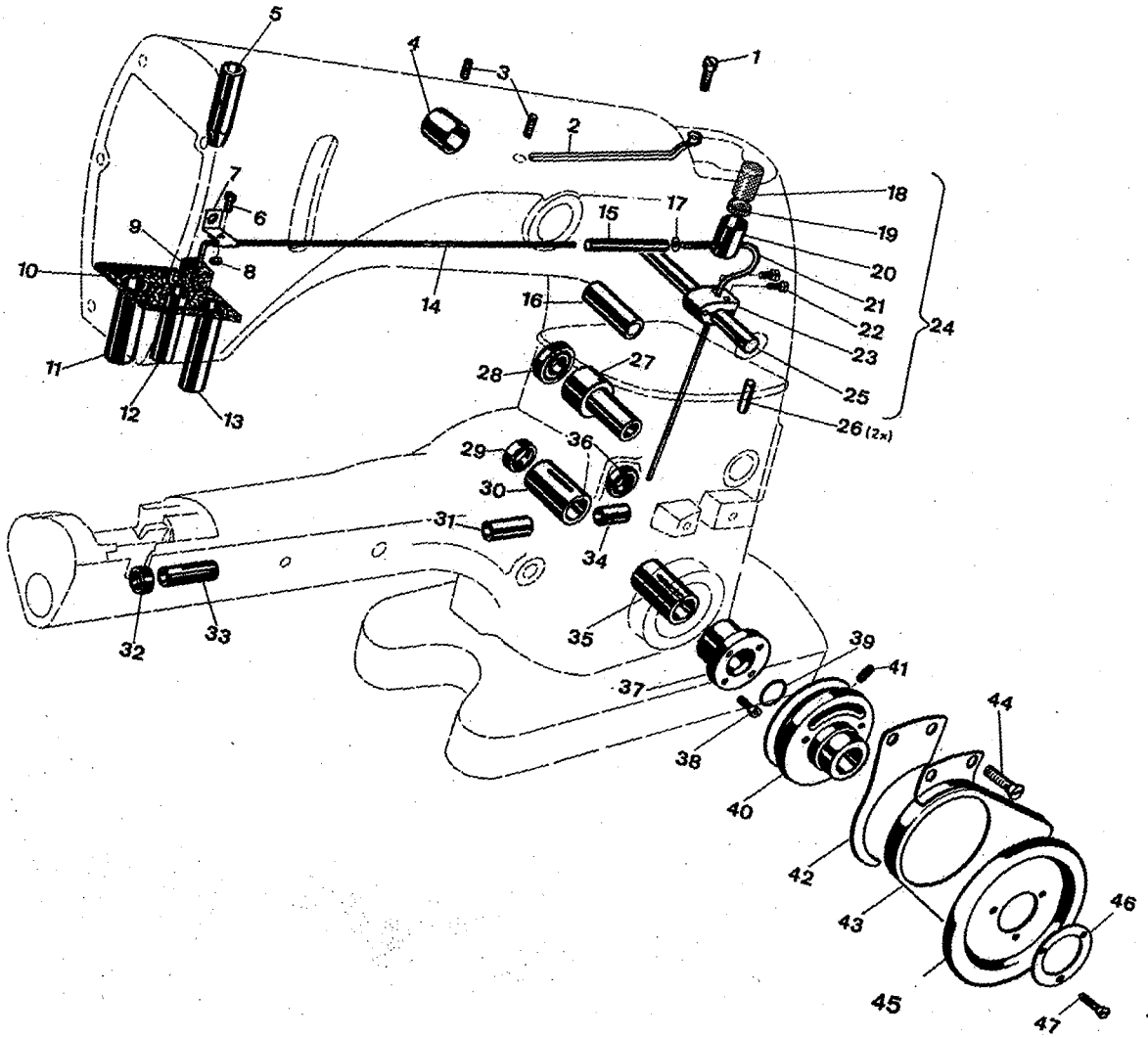

<u>Pos. Nr.</u>	<u>Teil Nr.</u>	<u>Bezeichnung</u>	<u>Description</u>	<u>Anzahl</u>
<u>Ref. No.</u>	<u>Part No.</u>			<u>Amt. Req.</u>
1	90	Schraube	Screw	1
2	33782 AE	Ölrinne	Needle Lever Bearing Oiler	1
3	719	Schraube	Screw	2
4	51150	Anschlagbüchse	Needle Lever Shaft Stop Collar	1
5	51254 C	N'Stge'Büchse oben	Needle Bar Bushing, upper	1
6	87 U	Schraube	Screw	1
7	31194 A	Ölrohrhalter	Oil Tube Clamp	1
8	43443 Q	Mutter	Nut	1
9	666-214	Filz	Felt Lint Filter	1
10	31194 B	Filz	Felt	1
11	80262 I	D'F'Führungsstangenbüchse	Bushing for Presser Guide Bar	1
12	51254 D	N'Stge'Büchse unten	Needle Bar Bushing, Lower	1
13	31155	D'F'Stangenbüchse	Bushing for Presser Bar	1
14	31194	Ölrohr	Oil Siphon Tube	1
15	51294 N	Ölsiphon-Verbindung	Oil Tube Connection	1
16	52883 R	D'F'Lifter Büchse	Presser Foot Lifter Lever Bushing	1
17	21212	Ring f.Ölsiphon-Verbindung	Oil Siphon Connection Locking Ring	1
18	666-201	Ölfilz	Felt Plug	1
19	666-209	Filzscheibe	Siphon Cup Disc, felt	1
20	G 50-521	Trichter f. Ölrohr	Siphon	1
21	G 50-520	Ölrohr	Oil Tube	1
22	75	Schraube	Screw	2
23	53394 R	Halter f. Ölsiphon	Oil Siphon Clamp	1
24	53394 P	Ölsiphon kompl.	Oil Siphon Assembly	1
25	21657 X	Büchse	Bushing	1
26	80699 A	Paßstift	Pin	2
27	31142 C	Bundbuchse	Bushing	1
28	999-1	Simmerring	Gasket	1
29	999-35	Simmerring	Gasket	1
30	31190 B	Hauptwellenbuchse links	Crankshaft Bushing	1
31	31140 A	Greiferachsbuchse	Bushing for Looper Bar	1
32	999-36	Simmerring	Gasket	1
33	31140	Greiferachsbuchse	Bushing for Looper Bar	1
34	31140 B	Greiferachsbuchse	Bushing for Looper Bar	1
35	31190 A	Buchse	Bushing	1
36	999-37	Simmerring nur f. Diff. Trsp.	Gasket for Diff. Feed only	1
37	31191	Kurbelwellenlager	Crankshaft Bushing Housing, including bushing	1
38	22569 B	Schraube	Screw	4
39	660-202	O-Ring	O"Ring	1
40	31121 A	Handrad	Pulley	1
41	22894 G	Schraube	Screw	2
42	31175 C	Stoffschutz	Cloth Guard	1
43	31275	Handradschutz	Belt-Guard	1
44	22581	Schraube	Screw	2
45	61321 J	Handrad (Kunststoff)	Handwheel	1
46	61321 L	Scheibe	Washer	1
47	22574	Schraube	Screw	3





Pos. Nr.	Teil Nr.	Bezeichnung	Description	Anzahl
Ref. No.	Part No.			Amt. Req.
1	31191 A	Dichtung	Gasket	1
2	22839 C	Schraube	Screw	4
3	22539 D	Verschlußschraube f. Stich- verstellung	Plug Screw	1
4	33782 E	Dichtung	Gasket	1
5	31182 N	Deckel	Cover	1
6	99274	Schraube	Screw	4
7	33782 B	Dichtung	Gasket	1
8	33782 Y	Ölspritzblech	Baffle Plate	1
9	90	Schraube	Screw	2
10	52882 P	Dichtung	Gasket	1
11	31282 B	Schraube	Screw	1
12	22541 B	Schraube	Screw	2
13	52882 AD	Armdeckel kompl.	Chamber Cover	1
14	39582 L	Klappdeckel	Oil Cap	1
15	52882 AC	Feder	Oil Cap Torsion Spring	1
16	50-789	Stift	Oil Cap Hinge Pin	1
17	52882 AA	Ölfangblech	Drip Plate	1
18	90	Schraube	Screw	2
19	31158 B	Fadenleitbügel	Needle Thread leading Wire	1
20	95	Schraube	Screw	1
21	22768	Schraube	Screw	1
22	31158 A	Fadenführung auf N'Stange	Needle Bar Thread Eyelet	1
23	33782 A	Kopfdeckeldichtung	Gasket	1
24	31170	Fadenabzugshaken	Pull-off Wire	1
25	22565	Schraube	Screw	1
26	31182 A	Kopfdeckel	Head Cover	1
27	22569	Schraube	Screw	5
28	22569 D	Schraube	Screw	1
29	57 WD	Ansatzschraube	Nipper Spring Screw	1
30	57 WC	Fadenspannungsfeder	Nipper Spring	1
31	57 WB	Fadenspannungsplättchen	Nipper Spring Plate	1
32	31158 E	Fadenspannungshalter- plättchen	Needle Thread Nipper Bore plättchen	1
33	31117	Nadelstange siehe Seite 7	Needle Bar	1
34	33758 D	Fadenführung am Nadelhebel	Needle Lever Thread Eyelet	1
35	G 52758	Fadenführung	Thread Eyelet	1
36	22768	Schraube	Screw	1
37	22889 A	Verschluß u. Aufnahme-Schr.	Plug Screw	1
38	20	Scheibe	Washer	1
39	22848	Schraube	Screw	1
40	99287	Schraube	Screw	1
41	99287 B	Schraube	Screw	1
42	31182	Zylinderdeckel	Cylinder Cover	1
43	99287 C	Schraube	Screw	1
44	999-41	Gummischnur f.31182	Rubber-string	2
45	31182 D	Scharnierdeckel kompl.	Cylinder Hinged Cover Assembly	1
46	96402	Niet	Rivet	2
47	31182 D-1	Scharnierdeckel	Cylinder Hinged Cover	1
48	31163 A	Blattfeder	Spring	1
49	31182 L	Dichtung	Gasket	1
50	31182 R	Dichtung	Gasket	1
51	31182 B	Haltebügel, vorn	Support for Cylinder Cover, front	1
52	31158 D	Fadenführung, hinten	Thread Eyelet, rear	1
53	22570	Schraube	Screw	1
54	M 129 C	Niet	Rivet	2
55	31182 T	Halteblech	Holding-plate	1
56	31182 S	Spritzlappen	Splash-leather	1
57	31182 K	Ölspritzblech	Baffle Plate	1
58	22766	Schraube	Screw	2
59	31182 C	Haltebügel, hinten	Support for Cylinder Cover, rear	1
60	31158 C	Fadenführung, vorn	Thread Eyelet, front	1
61	77 K	Schraube	Screw	1
62	31183	Scharnierschraube	Hinge Screw	1
63	999-78	Verschluß-Stopfen	Plug	1
64	99242	Schraube f.31182 B	Screw for 31182 B	2
65	22733 B	Ölablaßschraube	Oil Drain Plug Screw	1
66	G 50-434	Ölstandsauge	Lucite Oil Gauge	1
67	41394 A	Dichtungsring	Gasket	1
68	33782 C	Dichtung	Gasket	1
69	22585 A	Schraube	Screw	2
70	90939	Schraube	Screw	4
71	31138 H	Stift f. Zugfeder	Spring-pin	1
72 *	11638 M	Mutter	Nut	1
73 *	HA 86 B	Federscheibe	Spring Washer	1
74 *	999-32	<del>Dichtung</del> O Ring	Gasket	1
75 *	99292	Schraube	Screw	1
76	31258	Fadenösenhalter	Eyelet-Support	1
77	21114 L	Fadenöse	Eyelet	4
78	21114 M	Federring	Eyelet Locking Ring	4
79	96201	Federring	Locking Ring	1
80	11638 M	Mutter	Nut	1

*plain feed only*

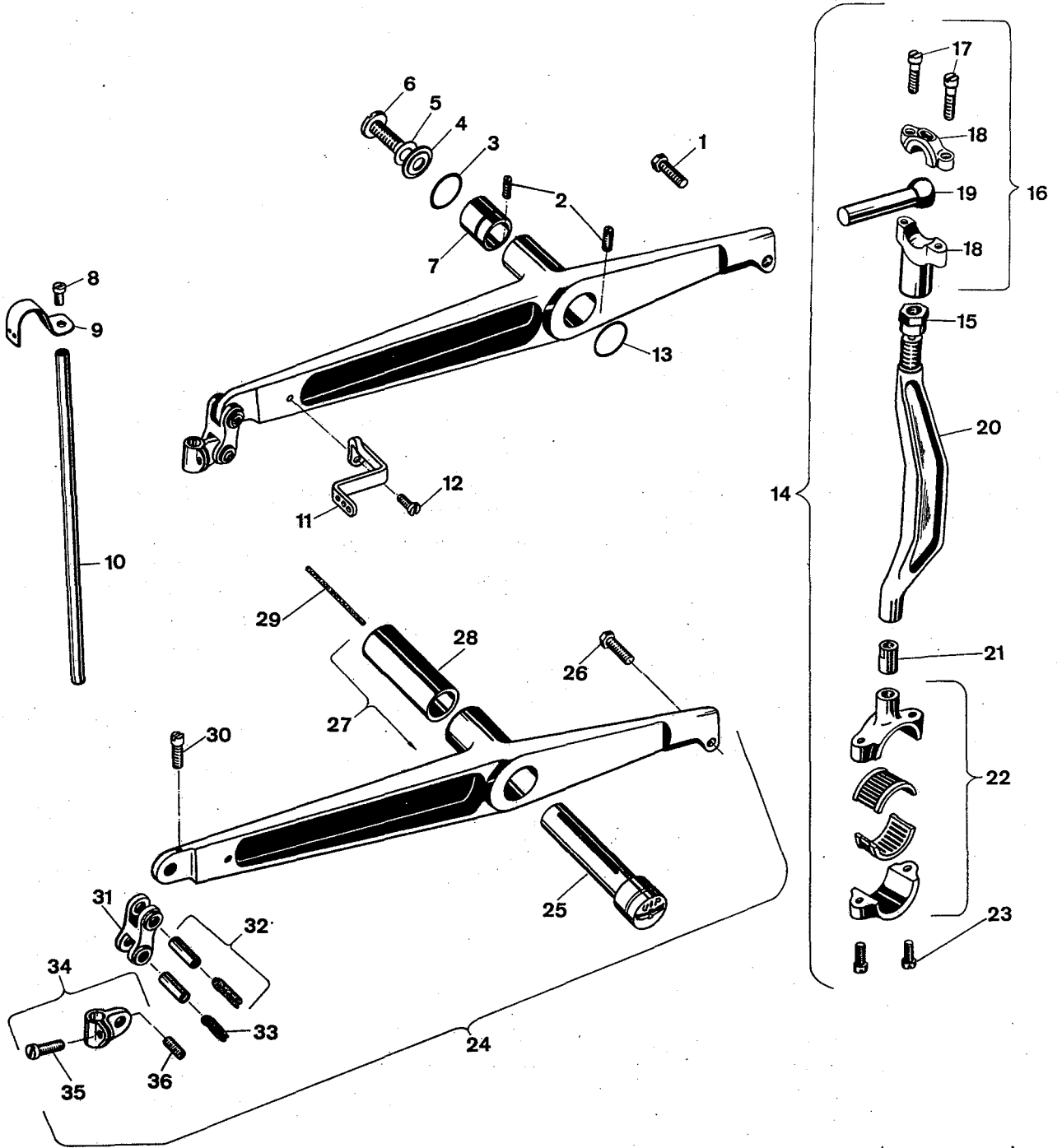

<u>Pos. Nr.</u>	<u>Teil Nr.</u>	<u>B e z e i c h n u n g</u>	<u>D e s c r i p t i o n</u>	<u>Anzahl</u>
<u>Ref. No.</u>	<u>Part No.</u>			<u>Amt. Req.</u>
1	BP108	Schraube	Screw	1
2	719	Schraube	Screw	2
3	660-212	Ölabstreifring	Oil Seal Ring	1
4	51250 D	U'Legscheibe	Washer	1
5	51250 F	Dichtungsscheibe	Gasket	1
6	22586 R	Schraube	Screw	1
7	51150	Anschlagbuchse	Needle Lever Shaft Stop Collar	1
8	22768	Schraube	Screw	1
9	31158 A	Fadenführung auf Nadelstange	Needle Bar Thread Eyelet	1
10	31117	Nadelstange	Needle Bar	1
11	33758 D	Fadenführung am Nadelhebel	Needle Lever Thread Eyelet	1
12	22768	Schraube	Screw	1
13	660-212	Ölabstreifring	Oil Seal Ring	1
14	G 29476 P	Nadelhebelverbindung kompl.	Needle Lever Rod Assembly	1
15	15430 C	Mutter links	Nut left Thread	1
16	G 29066 B	Kugellager kompl.	Needle Lever Ball Joint	1
17	97 A	Schraube	Screw	2
18	52816 G	Lagerschale	Needle Lever Ball Joint Bearing	1
19	31156	Kugelbolzen	Ball	1
20	31116 G	Nadelhebelverbindung	Needle Lever Rod	1
21	99290	Mutter	Nut	1
22	31116 A	Lagerschale	Needle Lever Ball Joint Bearing	1
23	75 A	Schraube	Screw	2
24	G 29348 E	Nadelhebel kompl.	Needle Lever Assembly	1
25	51250 E	Nadelhebelbolzen	Needle Lever Stud	1
26	BP 108	Schraube	Screw	1
27	31115	Nadelhebel	Needle Lever	1
28	51250 A	Büchse	Needle Lever Bushing	1
29	666-170	Öldocht	Oil Wick	1
30	77	Schraube	Screw	1
31	54	Verbindungsgelenk	Needle Bar Link	1
32	51054	Konischer Stift	Link Pin	2
33	666-149	Docht	Lubricating Felt	2
34	51254 H	Mitnehmer	Needle Bar Connection	1
35	22562 A	Schraube	Screw	1
36	78	Schraube	Screw	1

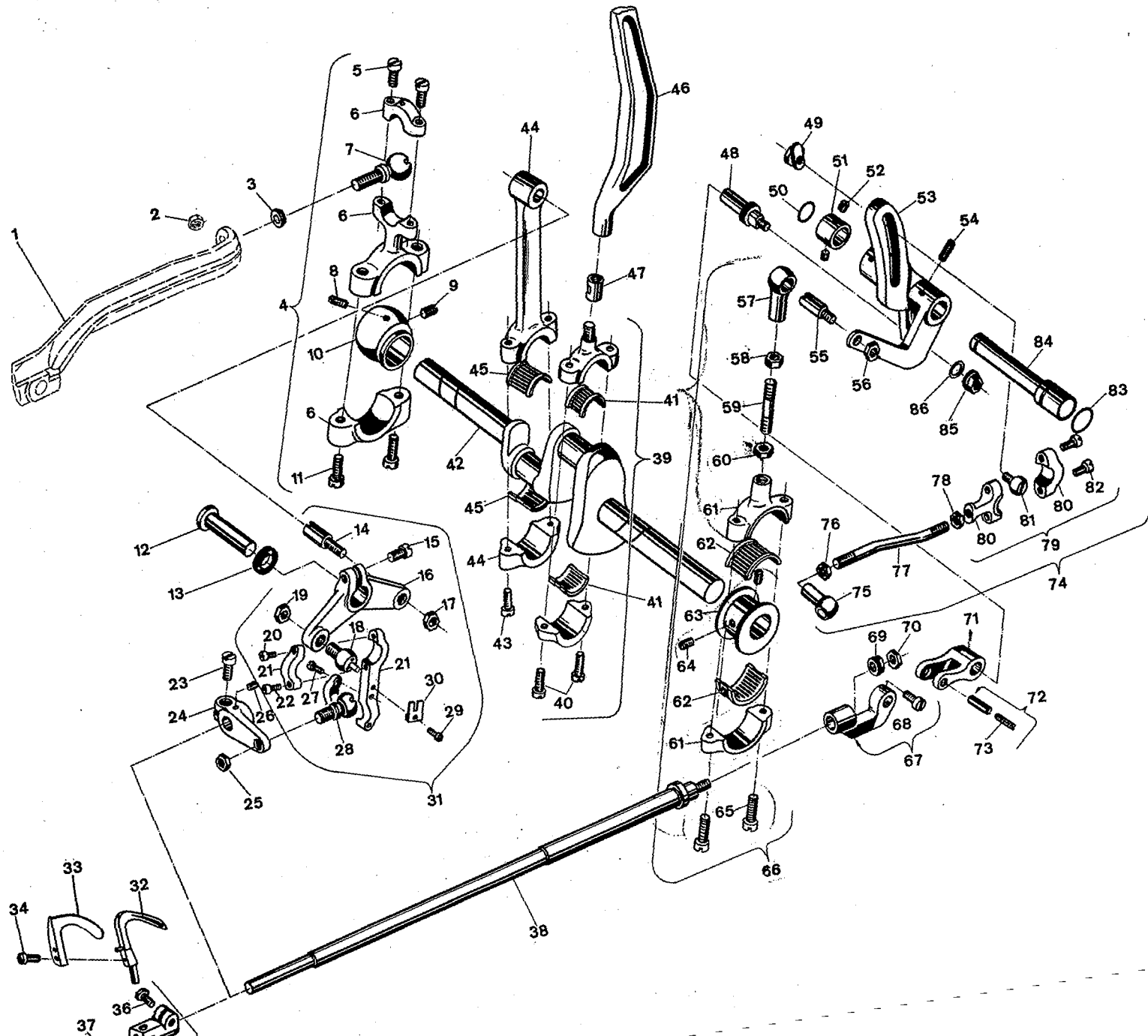

Pos. Nr.	Teil Nr.	Bezeichnung	Description	Anzahl
Ref. No.	Part No.			Amt.Reg.
1	31139	Transporthubhebel	Feed Rocker Arm	1
2	258	Mutter	Nut	1
3	35746 A	Scheibe	Washer	1
4	G 29476 S	Doppellager f.Transport- hub kompl.	Feed Lift Connection Assembly	1
5	97 A	Schraube	Screw	2
6	31139 B	Lagerschale	Bearing	1
7	35746 C	Kugelschraube	Ball	1
8	28 B	Schraube	Screw	1
9	22894 C	Schraube	Screw	2
10	31106 A	Exzenter	Eccentric	1
11	22559 C	Schraube	Screw	2
12	31142 A	Bundachse	<del>Bar</del> Looper Avoid Lever Shaft	1
13	999-1	Simmering	Gasket	1
14	31142 B	Bolzen	Link Pin	1
15	22517	Schraube	Screw	1
16	31142	Doppelhebel	Looper Drive Lever	1
17	12538	Mutter	Nut	1
18	31144 C	Kugelschraube	Ball	1
19	18	Mutter	Nut	1
20	G 97 A	Schraube	Screw	2
21	31144 B	Lagerschale	Bearing	1
22	97 A	Schraube	Screw	1
23	22517	Schraube	Screw	1
24	31144 G	Greiferantriebshebel	Looper Drive Lever Rocker Shaft	1
25	15037 A	Mutter	Nut	1
26	22733	Schraube	Screw	1
27	97 A	Schraube	Screw	2
28	31144 D	Kugelschraube	Ball	1
29	77 B	Schraube	Screw	1
30	31144 E	Führungsgabel	Guide Fork	1
31	31144 F	Antriebsgelenk kompl.	Looper Drive Lever and Link Assembly	1
32	31108	Greifer	Looper	1
33	31110 A	Greiferschutz	Looper Needle Guard	1
34	22798 A	Schraube	Screw	1
35	31113	Greiferhalter	Looper Holder	1
36	22792 C	Schraube	Screw	1
37	73	Schraube	Screw	1
38	31144	Greiferachse	Looper Rock Shaft	1
39	31116 A	Lagerschale	Bearing	1
40	75 A	Schraube	Screw	2
41	999-39	Nadelkäfig f.N'H'-Antriebslager	Needle Bearing	2
42	31122	Kurbelwelle	Crank Shaft	1
43	75 A	Schraube	Screw	2
44	31116 F	Greiferantriebsverbindungs- stange	Looper Drive Lever Connection	1
45	999-38	Nadelkäfig f.Greiferantriebs- lager	Needle Bearing	2
46	31116 G	Nadelhebelverbindung	Needle Lever Connection	1
47	99290	Mutter	Nut	1
48	11963	Kulissenbolzen	Stud for Looper Avoid Link	1
49	31133 L	Stellmutter f.Differential- transport-Maschine	Adjusting Nut for Differential Feed Machine	1
	31133 C	Stellmutter f.Einfachtrans- port-Maschine	Adjusting Nut for Plain Feed Machine	1
50	999-30	O-Ring	"O"-Ring	1
51	HA 482 A	Stelling	Collar	1
52	88	Schraube	Screw	2
53	31142 N	Transport u.Greifer-Antriebs- hebel	Feed Drive and Looper Avoid Drive Lever	1
54	22894 S	Schraube	Screw	1
55	31142 M	Gelenkbolzen	Link Pin	1
56	12538	Mutter	Nut	1
57	31116 D	Verbindungsgelenk	Link	1
58	12538	Mutter	Nut	1
59	G 43242 N	Gewindebolzen	Connecting Rod	1
60	43242 P	Mutter	Nut left Thread	1
61	31116	Lagerschale	Bearing	1
62	999-40	Nadellager f.Transport u. Greiferantriebsexzenter	Needle Bearing	2
63	31106	Exzenter	Eccentric	1
64	22894 C	Schraube	Screw	2
65	22559 C	Schraube	Screw	2
66	G 29476 N	Transportantriebsverbindung	Feed Drive and Looper Avoid Connection Assembly	1
67	31144 A	Gelenk	Looper Avoid Link	1
68	77	Schraube	Screw	1
69	462	Mutter	Nut	1
70	12538	Mutter	Nut	1
71	G 12055 N	Gr.Hebelgelenk	Looper Avoid Drive Link	1
72	51054	Gelenkstift	Link Pin	1
73	666-149	Docht	Oil Wick	1
74	31133 F	Verbindungsstange kompl.	Connection Rod Assembly	1
75	31116 D	Gelenk	Link	1
76	18	Mutter	Nut	1
77	31133 D	Verbindungsstange	Connection Rod	1
78	269	Mutter	Nut	1
79	31133 A	Lagerschale kompl.	Ball Bearing complete	1
80	52841 C	Lagerschale	Ball Bearing	1
81	31133 B	Kugelschraube	Ball	1
82	97 A	Schraube	Screw	2
83	999-32	O-Ring	"O"-Ring	1
84	31142 P	Achse f. 31142 N	Bar for 31142 N	1
85	462	Mutter	Nut	1
86	21657 E	Scheibe	Washer	1

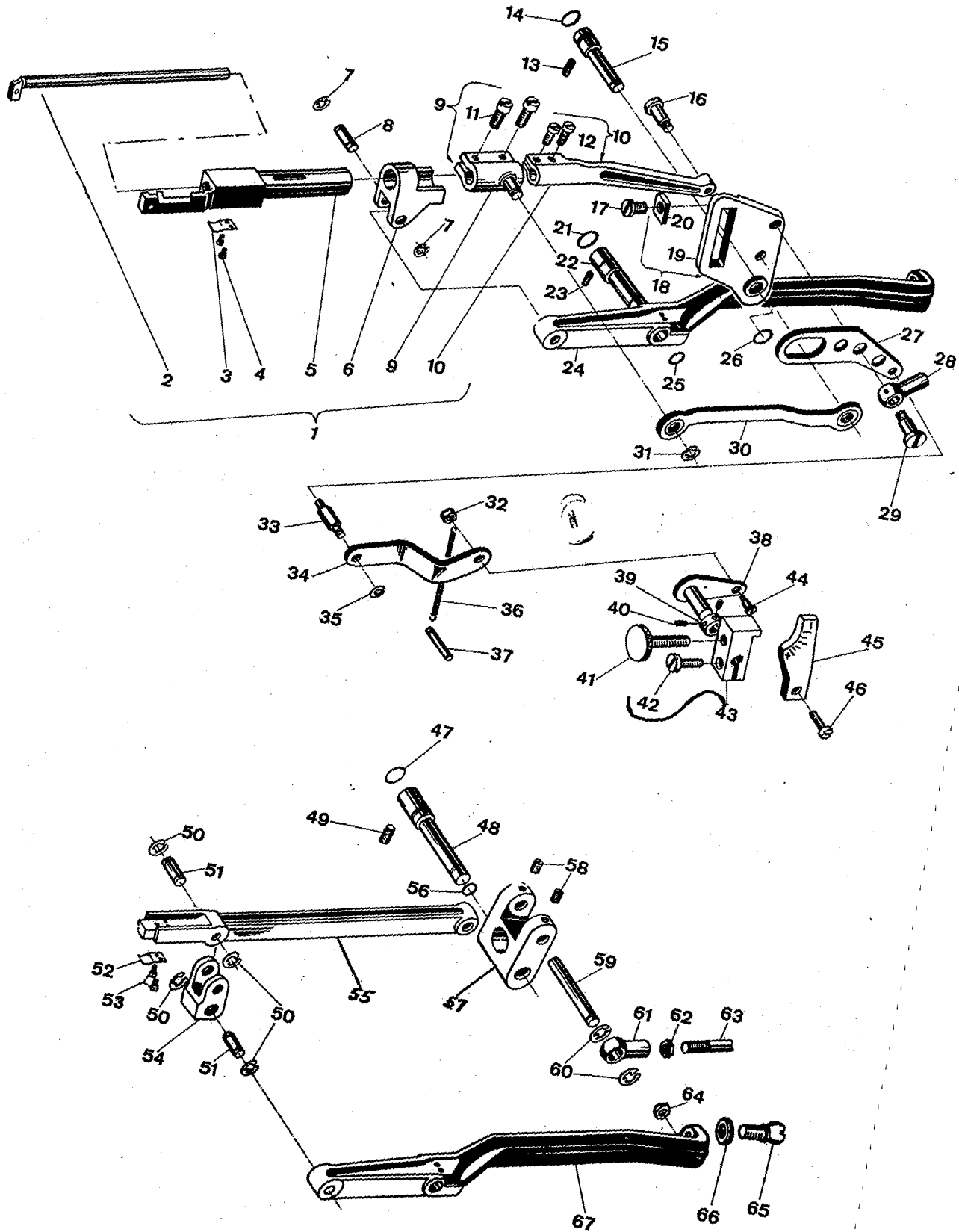

<u>Pos. Nr.</u>	<u>Teil Nr.</u>	<u>Bezeichnung</u>	<u>Description</u>	<u>Anzahl</u>
<u>Ref. No.</u>	<u>Part No.</u>			<u>Amt. Req.</u>
1	G 29459 R	Diff.Transport kompl.	Differential Feed Mechanism Assembly	1
2	31134	Haupttransporteurträger	Main Feed Bar	1
3	31134 K	Blattfeder	Spring	1
4	G 41228 A	Schraube	Screw	2
5	31134 H	Diff.Transporteurträger	Differential Feed Bar	1
6	31136	Transporteurträgerführung	Differential Feed Bar Guide	1
7	660-199	Seegerring	Retaining Ring	2
8	31136 A	Gelenkbolzen	Link Pin	1
9	31137	Pratzbolzen	Differential Feed Bar Clamp	1
10	31135 A	Pratzhebel	Differential Feed Bar Clamp	1
11	97	Schraube	Screw	2
12	22562 A	Schraube	Screw	2
13	22894 C	Schraube	Screw	1
14	999-34	O-Ring	"O"Ring	1
15	31135 C	Querachse f.31135 D	Feed Rocker Shaft	1
16	31135 B	Ansatzschraube	Screw	1
17	31137 D	Kulissenbolzen f.31137 A	Screw for Differential Feed Slide Block	1
18	31135 D	Transportrahmen kompl.	Feed Rocker complete	1
19	31135	Transportrahmen	Feed Rocker	1
20	31137 E	Gleitstein	Differential Feed Slide Block	1
21	999-30	O-Ring	"O"Ring	1
22	31139 A	Exzenter-Bolzen	Feed Bar Adjusting Pin	1
23	22894 S	Schraube f.31139 A	Screw	1
24	31139	Transporthubhebel	Feed Rocker Arm	1
25	999-31	O-Ring	"O"Ring	1
26	999-33	O-Ring	"O"Ring	1
27	31138 G	Verstellwinkelhebel	Differential Feed Adjusting Lever	1
28	31116 D	Verbindungsgelenk	Link	1
29	31133 E	Ansatzschraube	Screw	1
30	31137 A	Gelenkstange	Connection Rod	1
31	96275	Benzingsicherung f.31137	Retaining Ring	1
32	99300	Mutter f.31138 DA	Nut	1
33	31138 F	Distanzbolzen	Spacer Pin	1
34	31138 E	Gelenkverbindung	Connection	1
35	660-210	Benzingsicherung	Retaining Ring	1
36	96703	Zugfeder	Spring	1
37	31138 H	Stift	Pin	1
38	31138 CA	Verstellhebel	Differential Feed Adjusting Lever upper	1
39	52888 B	Stelling	Collar	1
40	22562	Schraube	Screw	2
41	99299	Rändelschraube	Thumb Screw	1
42	22517	Schraube	Screw	1
43	31138 J	Pratzhebel	Clamp for Differential Feed Adjusting Lever	1
44	31138 DA	Gelenkschraubenbolzen	Shoulder Screw	1
45	31138 AA	Skalen-Anschlag	Scale	1
46	22581	Schraube	Screw	1
47	999-34	O-Ring	"O"Ring	1
48	31135 C	Querachse	Feed Rocker Shaft	1
49	22894 C	Schraube f.31135 C	Screw	1
50	660-199	Seegerring	Retaining Ring	4
51	31136 A	Gelenkbolzen	Link Pin	2
52	31134 L	Blattfeder	Spring	1
53	G 41228 A	Schraube	Screw	2
54	31136 E	Transporteurträgerführung	Feed Bar Guide	1
55	31134 E	Transporteurträger	Feed Bar	1
56	999-33	O-Ring	"O"Ring	1
57	31135 E	Transportrahmen	Feed Rocker	1
58	90	Schraube	Screw	2
59	31135 F	Achse f.31135 E	Feed Bar Shaft	1
60	96275	Benzingsicherung	Retaining Ring	2
61	31116 D	Verbindungsgelenk	Link	1
62	18	Mutter Rechtsgew.	Nut left thread	1
63	31133 D	Verbindungsstange	Connection Rod	1
64	258	Mutter	Nut	1
65	35746 C	Kugelschraube	Ball	1
66	35746 A	Scheibe	Washer	1
67	31139	Transporthubhebel	Feed Rocker Arm	1

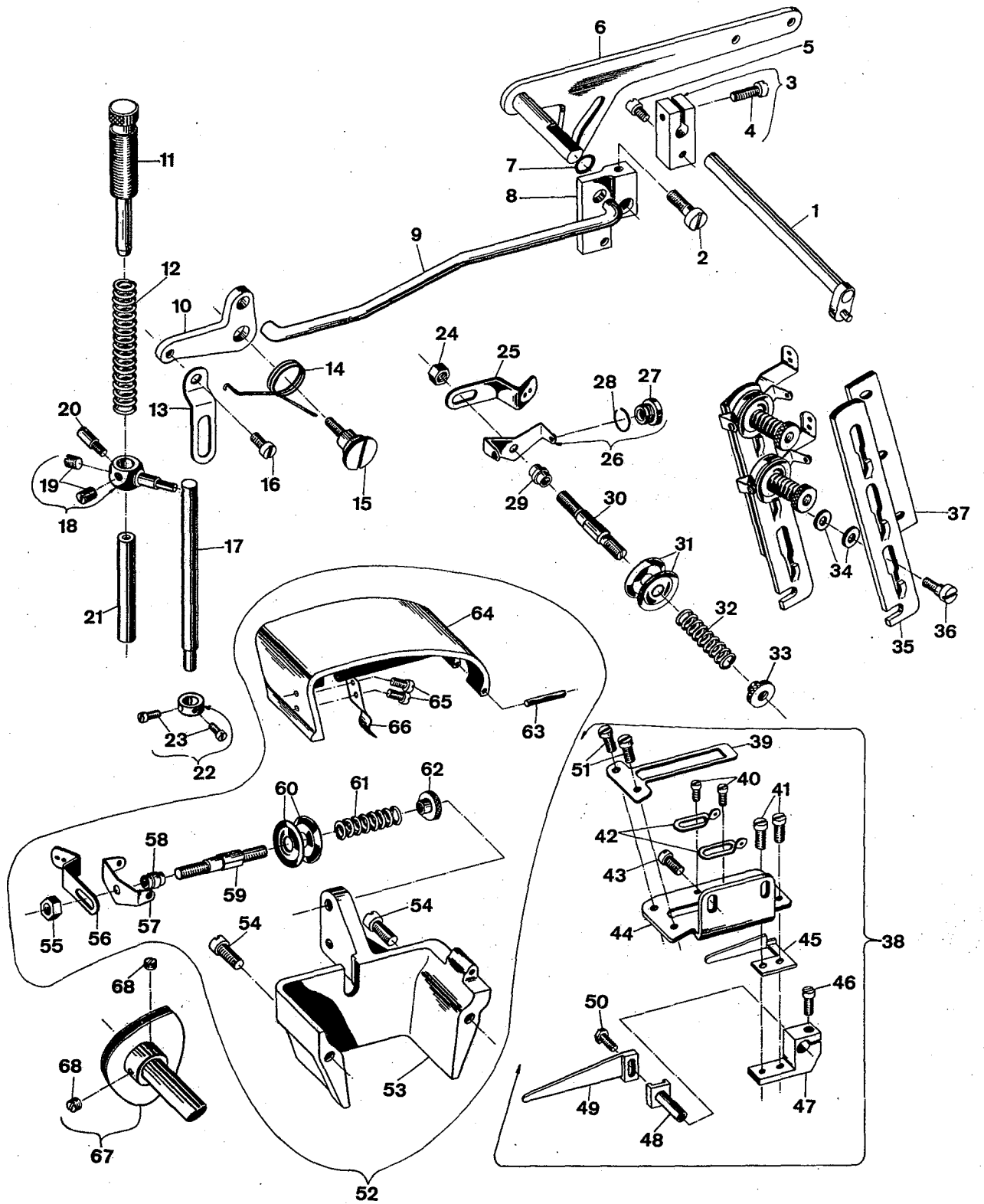



<u>Pos. Nr.</u>	<u>Teil Nr.</u>	<u>Bezeichnung</u>	<u>Description</u>	<u>Anzahl</u>
<u>Ref. No.</u>	<u>Part No.</u>			<u>Amt. Req.</u>
1	21657 W	Fadensp.-Öffnerstange	Tension Release Lever Shaft	1
2	318	Schraube	Screw	1
3	21657 Y	Verbindungsstück	Tension Release and Foot Lifter Lever Connection	1
4	22596	Schraube	Screw	1
5	402	Schraube	Screw	1
6	33783 H	Drückerfuß-Lifterhebel	Presser Foot Lifter Lever	1
7	660-207	Ölabstreifring	Oil Seal Ring	1
8	33783 N	Verbindungsstück zw.Lifterhebel u. Lifterhebelstange	Presser Foot Lifter Lever, internal	1
9	33783 M	Lifterverbindungsstange	Presser Foot Lifter Lever Connecting Rod	1
10	53783 L	Lifterzwischenhebel	Presser Foot Lifter Lever Bell Crank	1
11	51256 N	Drückerfuß-Regulier-u. Führungsbolzen	Presser Spring Regulator	1
12	51256 C	Drückerfußfeder	Presser Bar Spring	1
13	53783 A	Lifterhebelgelenk	Lifter Lever Link	1
14	33783 S	D'F'Lifterzwischenhebel-feder	Presser Foot Lifter Lever Bell Crank Spring	1
15	G 22557 B	Ansatzschraube	Screw	1
16	22758 C	Schraube	Screw	1
17	31160	Drückerfußstange	Presser Bar	1
18	33783	Drückerfußstangen-Mitnehmer	Presser Bar Connection	1
19	88	Schraube	Screw	2
20	G 402	Schraube	Screw	1
21	39135	Drückerfußführungsstange	Presser Bar Guide Bar	1
22	52888 B	Stellring f. D'fuß	Collar for Presser Foot	1
23	22562	Schraube	Screw	2
24	43266	Mutter	Nut	1
25	51491 C	Fadeneinführung	Thread Lead-in Guide	2
26	51292 D	Fadenführung	Tension Thread Eyelet	2
27	668-25	Fadenführungshülse	Eyelet	4
28	668-28	Federring	Eyelet Locking Ring	4
29	51292 A	Fadenspannungshülse	Tension Post Ferrule	2
30	51292 G	Fadenspannungsbolzen	Tension Post	2
31	109	F'Sp'Scheibe	Tension Disc	4
32	51292 F-8	N'F'Sp.-Feder	Tension Spring-needle	2
33	51292 C	F'Sp'Mutter	Tension Nut	2
34	80557	Scheibe	Washer	2
35	21657-3	Fadenentspanner	Tension Disc Separator	1
36	22598 C	Schraube	Screw	1
37	52892	Fadenspannungsträger	Tension Post Support	1
38	G 29389 TA	Fadenabzugsplatte	Take-up Shield complete	1
39	53304 B	Fadenabstreifer	Cast-off Plate	1
40	73 A	Schraube	Screw	2
41	J 87 J	Schraube	Screw	2
42	52958 D	Fadenführung	Eyelet	2
43	94	Schraube	Screw	2
44	31157 A	Abzugsplatte	Take-up Shield	1
45	53304 C	Fadenabzugshaken	Cast-off	1
46	22729	Schraube	Screw	1
47	52804 F	Träger	Cast-off and Retaining Finger Support Bracket	1
48	52804 E	Halter	Retainer Support	1
49	31104	Fadenabzugsfinger	Retaining Finger	1
50	22588 A	Sechskantschraube	Screw	1
51	28	Schraube	Screw	2
52	31182 E	Abdeckkasten f.Fadenaufnehmer kpl.	Case for Take-up complete	1
53	31182 G	Abdeckkasten	Case for Take-up	1
54	22517	Schraube	Screw	2
55	G 43266	Mutter	Nut	1
56	51491 C	Fadeneinführung	Thread Lead in Guide	1
57	51292 D	Fadenführung	Tension Thread Eyelet	1
58	51292 A	Fadenspannungshülse	Tension Post Ferrule	1
59	51292 G	Fadenspannungsbolzen	Tension Post	1
60	109	F'Sp'Scheibe	Tension Disc	2
61	51292 F-2	Feder	Spring	1
62	51292 C	F'Sp'Mutter	Tension Nut	1
63	96500	Stift	Pin	1
64	31182 F	Deckel	Cover	1
65	22768	Schraube	Screw	2
66	31163	Feder	Spring	1
67	31123	Fadenaufnehmer	Looper Thread Take-up	1
68	22580 D	Schraube	Screw	2

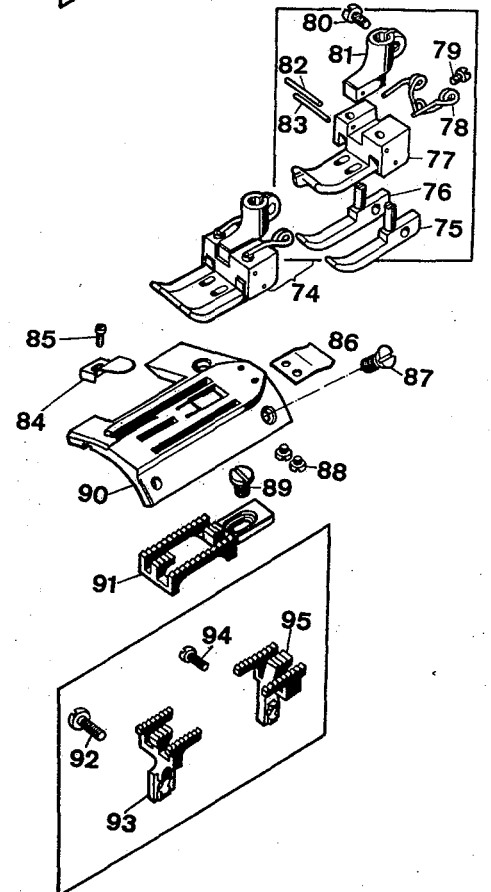
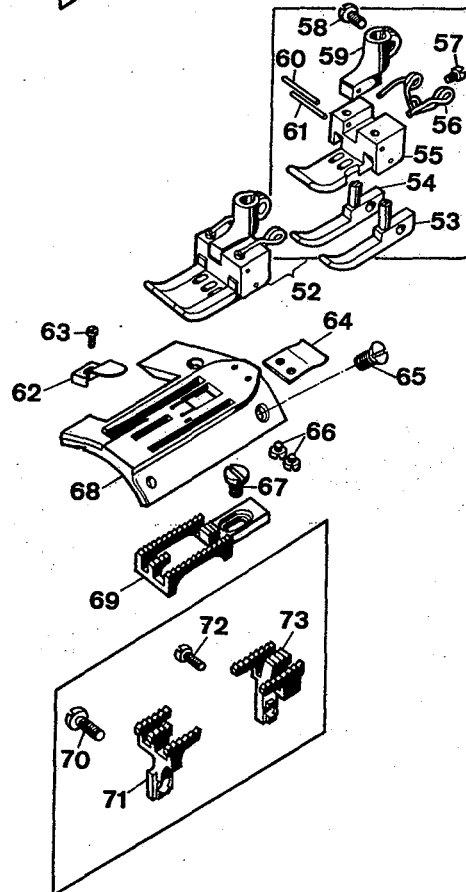
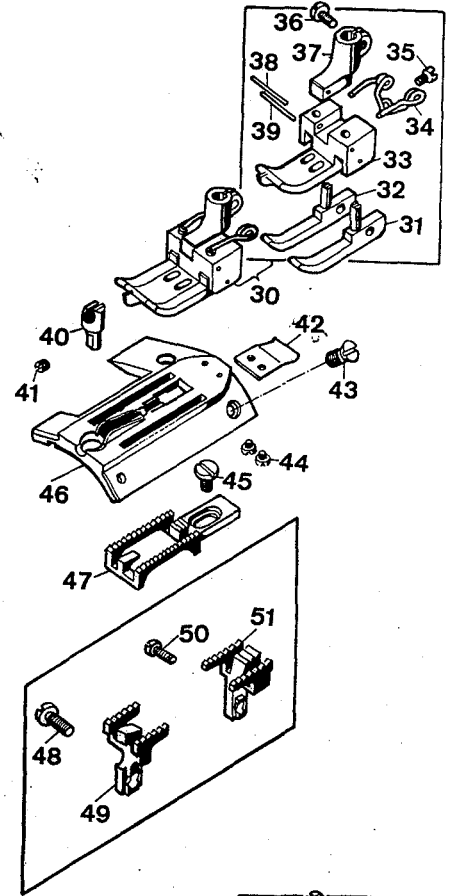
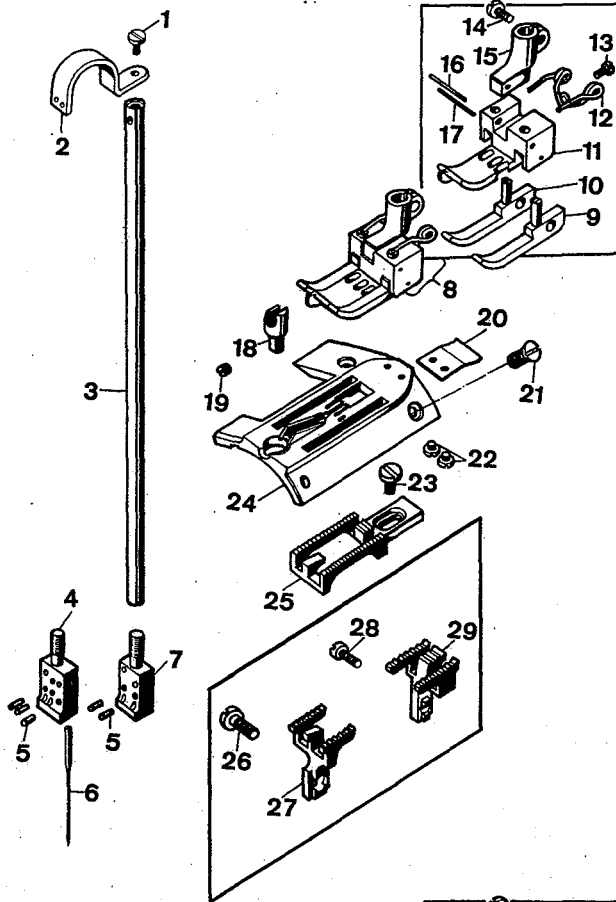

<u>Pos. Nr.</u>	<u>Teil Nr.</u>	<u>Bezeichnung</u>	<u>Description</u>	<u>Anzahl</u>
<u>Ref. No.</u>	<u>Part No.</u>			<u>Amt. Req.</u>
1	22768	Schraube	Screw	1
2	31158 A	Fadenführung auf Nadelstange	Needle Bar Thread Eyelet	1
3	31117	Nadelstange	Needle Bar	1
4	31118-8	Nadelkopf 8 ga f.Kl.31100E-8	Needle Holder 8ga for Style 31100 E-8	1
	31118-12	Nadelkopf 12ga f.Kl.31100E-12 K-12 u. L-12	Needle Holder 12ga for Styles 31100 E-12, K-12 and L-12	1
5	73 B	Schraube	Screw	5
6	31111	Blind-Nadel	Retainer-Needle	1
7	31118-16	Nadelkopf 16ga f.Kl.31100E-16 K-16 u. L-16	Needle Holder 16ga for Styles 31100 E-16, K-16 and L-16	1
8	31120-8	Drückerfuß 8ga f.Kl.31100E-8	Presser Foot 8ga for Style 31100 E-8	1
	31120-12	Drückerfuß 12ga f.Kl.31100E-12 K-12 u. L-12	Presser Foot 12ga for Styles 31100 E-12, K-12 and L-12	1
9	31130 R	Drückerfußseitenteil	Yielding Section, right	1
10	31130 L	Drückerfußseitenteil	Yielding Section, left	1
11	31130 B-8	Drückerfußsohle 8ga	Presser Foot Bottom 8ga	1
	31130 B-12	Drückerfußsohle 12ga	Presser Foot Bottom 12ga	1
12	G 11940	Drückerfußfeder	Spring	1
13	605 C	Schraube	Screw	1
14	91	Schraube	Screw	1
15	31130 A	Drückerfußnabe	Presser Foot Shank	1
16	M-25	Stift 1,4 $\phi$ x10,5 lg.	Pin 1,4 $\phi$ x 10,5 mm long	1
17	M-25	Stift 1,4 $\phi$ x21,6 lg.	Pin 1,4 $\phi$ x 21,6 mm long	1
18	31103	Nahtführung	Seam-Guide	1
19	28 C	Schraube	Screw	1
20	31134 K	Blattfeder	Spring	1
21	22524	Schraube	Screw	2
22	G 41228 A	Schraube	Screw	2
23	99293	Schraube	Screw	1
24	31124-8	Stichplatte 8ga f.Kl.31100E-8	Throat Plate 8ga for Style 31100 E-8	1
	31124-12	Stichplatte 12ga f. Kl. 31100 E-12, K-12 u. L-12	Throat Plate 12ga for Styles 31100 E-12, K-12 and L-12	1
25	31105 E-8	Transporteur f.Kl.31100E-8 u. E-12	Feed Dog for Style 31100E-8 and E-12	1
26	22528	Schraube	Screw	1
27	31126 KA-8	Differentialtransporteur f.Kl. 31100 K-12	Differential Feed Dog for Style 31100 K-12	1
	31126 LA-8	Differentialtransporteur f.Kl. 31100 L-12	Differential Feed Dog for Style 31100 L-12	1
28	22562 A	Schraube	Screw	1
29	31105 K-8	Transporteur f.Kl.31100K-12	Feed Dog for Style 31100 K-12	1
	31105 L-8	Transporteur f.Kl.31100L-12	Feed Dog for Style 31100 L-12	1
30	31120-16	Drückerfuß 16ga f.Kl.31100E-16 K-16 u. L-16	Presser Foot 16ga for Styles 31100 E-16, K-16 and L-16	1
31	31130 R	Drückerfußseitenteil	Yielding Section, right	1
32	31130 L	Drückerfußseitenteil	Yielding Section, left	1
33	31130 B-16	Drückerfußsohle	Presser Foot Bottem	1
34	G 11940	Drückerfußfeder	Spring	1
35	605 C	Schraube	Screw	1
36	91	Schraube	Screw	1
37	31130 A	Drückerfußnabe	Presser Foot Shank	1
38	M-25	Stift 1,4 $\phi$ x 9,5 lg.	Pin 1,4 $\phi$ x 9,5 mm long	1
39	M-25	Stift 1,4 $\phi$ x20,6 lg.	Pin 1,4 $\phi$ x20,6 mm long	1
40	31103	Nahtführung	Seam-Guide	1
41	28 C	Schraube	Screw	1
42	31134 K	Blattfeder	Spring	1
43	22524	Schraube	Screw	2
44	G 41228 A	Schraube	Screw	2
45	99293	Schraube	Screw	1
46	31124-16	Stichplatte 16ga f. Kl. 31100 E-16, K-16 u. L-16	Throat Plate 16ga for Styles 31100 E-16, K-16 and L-16	1
47	31105 E-16	Transporteur f.Kl.31100E-16	Feed Dog for Styles 31100 E-16, K-16 and L-16	1
48	22528	Schraube	Screw	1
49	31126 KA-16	Differentialtransporteur f.Kl. 31100 K-16	Differential Feed Dog for Styles 31100 K-16	1
	31126 LA-16	Differentialtransporteur f.Kl. 31100 L-16	Differential Feed Dog for Style 31100 L-16	1
50	22562 A	Schraube	Screw	1
51	31105 K-16	Transporteur f.Kl.31100K-16	Feed Dog for Style 31100K-16	1
	31105 L-16	Transporteur f.Kl.31100L-16	Feed Dog for Style 31100L-16	1
52	31120 F-12	Saum-Drückerfuß 12 ga	Presser Foot 12 ga for Hemming operation	1
53	31130 R	Drückerfußseitenteil	Yielding Section, right	1
54	31130 L	Drückerfußseitenteil	Yielding Section, left	1
55	31130 F-12	Drückerfußsohle	Presser Foot Bottom	1
56	G 11940	Drückerfußfeder	Spring	1
57	605 C	Schraube	Screw	1
58 - 95	siehe folgende Seite		see following page	

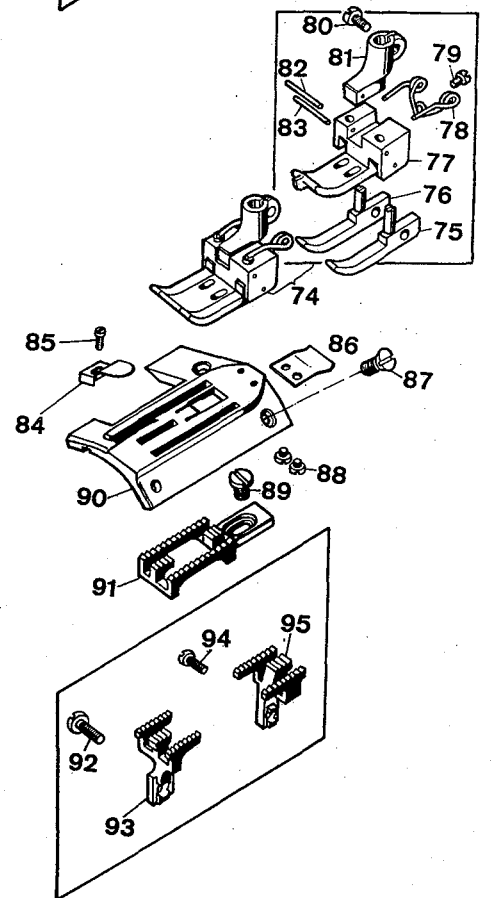
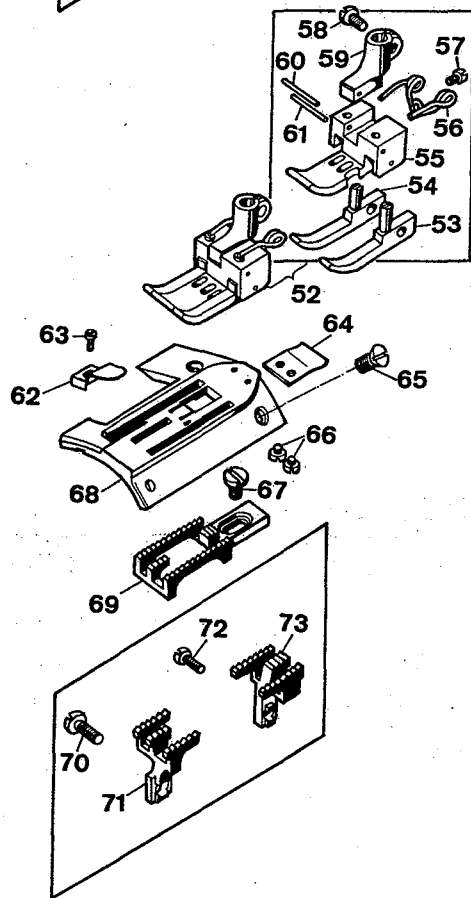
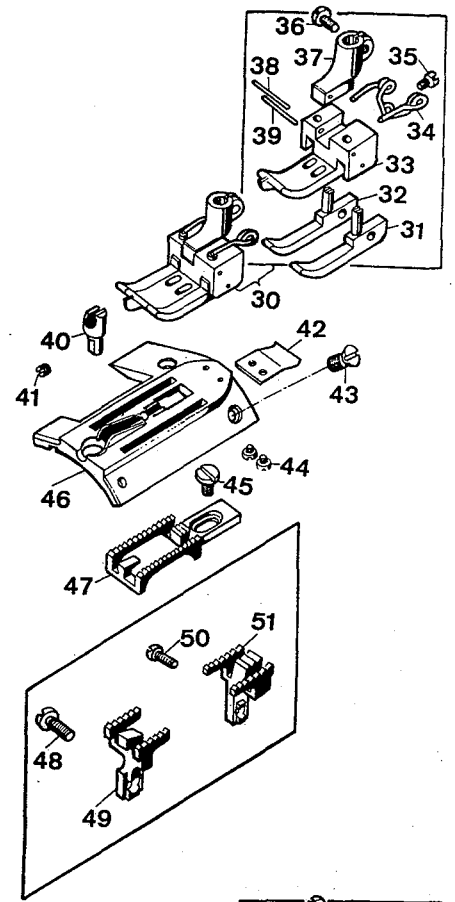
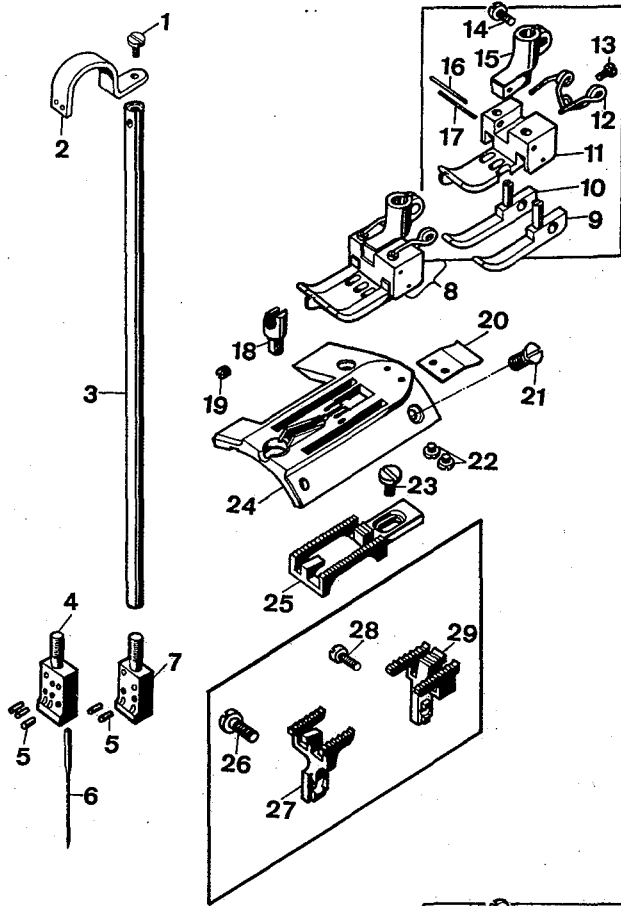

<u>Pos. Nr.</u>	<u>Teil Nr.</u>	<u>Bezeichnung</u>	<u>Description</u>	<u>Anzahl</u>
<u>Ref. No.</u>	<u>Part No.</u>			<u>Amt. Req.</u>
1 - 57		siehe vorhergehende Seite	see preceding page	
58	91	Schraube	Screw	1
59	31130 A	Drückerfußnabe	Presser Foot Shank	1
60	M-25	Stift 1,4 Ø x 10,5 lg.	Pin 1,4 Ø x 10,5 mm long	1
61	M-25	Stift 1,4 Ø x 21,6 lg.	Pin 1,4 Ø x 21,6 mm long	1
62	31103 F	Saumwinkel	Hemming Guide	1
63	22737	Schraube	Screw	1
64	31134 K	Blattfeder	Spring	1
65	22524	Schraube	Screw	2
66	G 41228 A	Schraube	Screw	2
67	99293	Schraube	Screw	2
68	31124 F-12	Stichplatte 12ga f. Saumarbeiten auf Einfach-u. Differentialtransportmaschine	Throat Plate 12ga for hemming operation on plain feed and differential feed machine	1
69	31105 F-8	Transporteur für 8 u. 12ga für Saumarbeiten auf Einfachtransportmaschine	Feed Dog for Nos. 8 and 12ga for hemming operations on plain feed machine	1
70	22528	Schraube	Screw	1
71	31126 KF-8	Differential-Transporteur f. 8 u. 12ga für Saumarbeiten auf Differentialtransportmaschine, Zahnung 2,6 mm	Differential Feed Dog for Nos. 8 and 12ga for hemming operations on differential feed machine, teeth cut 10 to inch	1
	31126 LF-8	Differential-Transporteur f. 8 u. 12ga für Saumarbeiten auf Differentialtransportmaschine, Zahnung 1,6 mm	Differential Feed Dog for Nos. 8 and 12ga for hemming operations on differential feed machine, teeth cut 16 to inch	1
72	22562 A	Schraube	Screw	1
73	31105 K-8	Transporteur für 8 u. 12ga f. Differentialtransportmaschine, Zahnung 2,6 mm	Feed Dog for Nos. 8 and 12ga for differential feed machine, teeth cut 10 to inch	1
	31105 L-8	Transporteur für 8 u. 12ga für Differentialtransportmaschine, Zahnung 1,6 mm	Feed Dog for Nos. 8 and 12ga for differential feed machine, teeth cut 16 to inch.	1
74	31120 F-16	Drückerfuß 16ga für Saumarbeiten auf Einfach-u. Differentialtransportmaschine	Presser Foot 16ga for hemming operation on plain feed and differential feed machine	1
75	31130 R	Drückerfußseitenteil	Yielding Section, right	1
76	31130 L	Drückerfußseitenteil	Yielding Section, left	1
77	31130 F-16	Drückerfußsohle	Presser Foot Bottom	1
78	G 11940	Drückerfußfeder	Spring	1
79	605 C	Schraube	Screw	1
80	91	Schraube	Screw	1
81	31130 A	Drückerfußnabe	Presser Foot Shank	1
82	M-25	Stift 1,4 Ø x 9,5 lg.	Pin 1,4 Ø x 9,5 mm long	1
83	M-25	Stift 1,4 Ø x 20,5 lg.	Pin 1,4 Ø x 20,5 mm long	1
84	31103 F	Saumwinkel	Hemming-Guide	1
85	22737	Schraube	Screw	1
86	31134 K	Blattfeder	Spring	1
87	22524	Schraube	Screw	2
88	G 41228 A	Schraube	Screw	2
89	99293	Schraube	Screw	1
90	31124 F-16	Stichplatte 16ga für Saumarbeiten auf Einfach-u. Differentialtransportmaschine	Throat Plate 16ga for hemming operation on plain feed and differential feed machine	1
91	31105 F-16	Transporteur 16ga für Saumarbeiten auf Einfachtransportmaschine	Feed Dog for Nos. 16ga for hemming operation on plain feed machine	1
92	22528	Schraube	Screw	1
93	31126 KF-16	Diff.-Transporteur 16ga f. Saumarbeiten auf Differentialtransportmaschine, Zahnung 2,6 mm	Differential Feed Dog for Nos. 16ga for hemming operation on differential feed machine, teeth cut 10 to inch	1
	31126 LF-16	Diff.-Transporteur 16ga f. Saumarbeiten auf Differentialtransportmaschine, Zahnung 1,6 mm	Differential Feed Dog for Nos. 16ga for hemming operation on differential feed machine, teeth cut 16 to inch	1
94	22562 A	Schraube	Screw	1
95	31105 K-16	Transporteur 16ga für Differentialtransportmaschine, Zahnung 2,6 mm	Feed Dog for Nos. 16ga for differential feed machine, teeth cut 10 to inch	1
	31105 L-16	Transporteur 16ga für Differentialtransportmaschine, Zahnung 1,6 mm	Feed Dog for Nos. 16ga for differential feed machine, teeth cut 16 to inch	1

AUF WELCHER SEITE FINDE ICH TEILE UND IHRE ABBILDUNGEN ?  
NUMERICAL INDEX OF PARTS .

<u>Teil Nr.</u>	<u>Seite</u>	<u>Teil Nr.</u>	<u>Seite</u>	<u>Teil Nr.</u>	<u>Seite</u>	<u>Teil Nr.</u>	<u>Seite</u>
<u>Part No.</u>	<u>Page</u>	<u>Part No.</u>	<u>Page</u>	<u>Part No.</u>	<u>Page</u>	<u>Part No.</u>	<u>Page</u>
18.....	4,5	G 22557 B.....	6	31130 F-16.....	8	31194 A.....	1
20.....	2	22559 C.....	4	31130 L.....	7,8	31194 B.....	1
M-25.....	7,8	22562.....	5,6	31130 R.....	7,8	31258.....	2
28.....	6	22562 A.....	3,5,7,8	31133.....	4	31275.....	1
28 B.....	4	22565.....	2	31133 A.....	4	31282 B.....	2
28 C.....	7	22569.....	2	31133 B.....	4	33758 D.....	2,3
G 50-434.....	2	22569 B.....	1	31133 C.....	4	33782 A.....	2
G 50-520.....	1	22569 D.....	2	31133 D.....	4,5	33782 B.....	2
G 50-521.....	1	22570.....	2	31133 E.....	5	33782 C.....	2
50-789.....	2	22574.....	1	31133 L.....	4	33782 E.....	2
54.....	3	22580 D.....	6	31134.....	5	33782 Y.....	2
57 WB.....	2	22581.....	1,5	31134 E.....	5	33782 AE.....	1
57 WC.....	2	22585 A.....	2	31134 H.....	5	33783.....	6
57 WD.....	2	22586 R.....	3	31134 K.....	5,7,8	33783 H.....	6
73.....	4	22588 A.....	6	31134 L.....	5	33783 M.....	6
73 A.....	6	22596.....	6	31135.....	5	33783 N.....	6
73 B.....	7	22598 C.....	6	31135 A.....	5	33783 S.....	6
75.....	1	22729.....	6	31135 B.....	5	35746 A.....	4,5
75 A.....	3,4	22733.....	4	31135 C.....	5	35746 C.....	4,5
77.....	3,4	22733 B.....	2	31135 D.....	5	39135.....	6
77 B.....	4	22737.....	8	31135 E.....	5	39582 L.....	2
77 K.....	2	22758 C.....	6	31135 F.....	5	G 41228 A.....	5,7,8
78.....	3	22766.....	2	31136.....	5	41394 A.....	2
HA 86 B.....	2	22768.....	2,3,6,7	31136 A.....	5	G 43242 N.....	4
J 87 J.....	6	22792 C.....	4	31136 E.....	5	43242 P.....	4
87 U.....	1	22798 A.....	4	31137.....	5	43266.....	6
88.....	4,6	22839 C.....	2	31137 A.....	5	G 43266.....	6
90.....	1,2,5	22848.....	2	31137 D.....	5	43443 Q.....	1
91.....	7,8	22889 A.....	2	31137 E.....	5	51054.....	3,4
94.....	6	22894 C.....	4,5	31138 E.....	5	51150.....	1,3
95.....	2	22894 G.....	1	31138 F.....	5	51250 A.....	3
97.....	5	22894 G.....	4,5	31138 G.....	5	51250 D.....	3
97 A.....	3,4	G 29066 B.....	3	31138 H.....	2,5	51250 E.....	3
G 97 A.....	4	G 29348 E.....	3	31138 J.....	5	51250 F.....	3
BP108.....	3	G 29389 TA.....	6	31138 AA.....	5	51254 C.....	1
109.....	6	G 29459 R.....	5	31138 CA.....	5	51254 D.....	1
M 129 C.....	2	G 29476 N.....	4	31138 DA.....	5	51254 H.....	3
258.....	4,5	G 29476 P.....	3	31139.....	4,5	51256 C.....	6
269.....	4	G 29476 S.....	4	31139 A.....	5	51256 N.....	6
318.....	6	31103.....	7	31139 B.....	4	51292 A.....	6
402.....	6	31103 F.....	8	31140.....	1	51292 C.....	6
G 402.....	6	31104.....	6	31140 A.....	1	51292 D.....	6
462.....	4	31105 E-8.....	7	31140 B.....	1	51292 F-2.....	6
HA 482 A.....	4	31105 E-16.....	7	31142.....	4	51292 F-8.....	6
605 C.....	7,8	31105 F-8.....	8	31142 A.....	4	51292 G.....	6
660-199.....	5	31105 F-16.....	8	31142 B.....	4	51294 N.....	1
660-202.....	1	31105 K-8.....	7,8	31142 C.....	1	51491 C.....	6
660-207.....	6	31105 K-16.....	7,8	31142 M.....	4	G 52758.....	2
660-210.....	5	31105 L-8.....	7,8	31142 N.....	4	52804 E.....	6
660-212.....	3	31105 L-16.....	7,8	31142 P.....	4	52804 F.....	6
666-149.....	3,4	31106.....	4	31144.....	4	52816 G.....	3
666-170.....	3	31106 A.....	4	31144 A.....	4	52841 C.....	4
666-201.....	1	31108.....	4	31144 B.....	4	52882 P.....	2
666-209.....	1	31110 A.....	4	31144 C.....	4	52882 AA.....	2
666-214.....	1	31111.....	7	31144 D.....	4	52882 AC.....	2
668-25.....	6	31113.....	4	31144 E.....	4	52882 AD.....	2
668-28.....	6	31115.....	3	31144 F.....	4	52883 R.....	1
719.....	1,3	31116.....	4	31144 G.....	4	52888 B.....	5,6
999-1.....	1,4	31116 A.....	3,4	31155.....	1	52892.....	6
999-30.....	4,5	31116 D.....	4,5	31156.....	3	52958 D.....	6
999-31.....	5	31116 F.....	4	31157 A.....	6	53304 B.....	6
999-32.....	2,4	31116 G.....	3,4	31158 A.....	2,3,7	53304 C.....	6
999-33.....	5	31117.....	2,3,7	31158 B.....	2	53394 P.....	1
999-34.....	5	31118-8.....	7	31158 C.....	2	53394 R.....	1
999-35.....	1	31118-12.....	7	31158 D.....	2	53783 A.....	6
999-36.....	1	31118-16.....	7	31158 E.....	2	53783 L.....	6
999-37.....	1	31120-8.....	7	31160.....	6	61321 J.....	1
999-38.....	4	31120-12.....	7	31163.....	6	61321 L.....	1
999-39.....	4	31120-16.....	7	31163 A.....	2	80262 I.....	1
999-40.....	4	31120 F-12.....	7	31170.....	2	80557.....	6
999-41.....	2	31120 F-16.....	8	31175 C.....	1	80699 A.....	1
999-78.....	2	31121 A.....	1	31182.....	2	90939.....	2
11638.....	2	31122.....	4	31182 A.....	2	96201.....	2
G 11940.....	7,8	31123.....	6	31182 B.....	2	96275.....	5
11963.....	4	31124-8.....	7	31182 C.....	2	96402.....	2
G 12055 N.....	4	31124-12.....	7	31182 D.....	2	96500.....	6
12538.....	4	31124-16.....	7	31182 E.....	2	96703.....	5
15037 A.....	4	31124 F-12.....	8	31182 F.....	6	99242.....	2
15430 C.....	3	31124 F-16.....	8	31182 G.....	6	99274.....	2
21114 L.....	2	31126 KA-8.....	7	31182 H.....	6	99287.....	2
21114 M.....	2	31126 FA-16.....	7	31182 K.....	2	99287 B.....	2
21212.....	1	31126 KF-8.....	8	31182 L.....	2	99287 C.....	2
21657-3.....	6	31126 LA-8.....	8	31182 N.....	2	99290.....	3,4
21657 E.....	4	31126 LA-16.....	7	31182 R.....	2	99292.....	2
21657 W.....	6	31126 LA-16.....	7	31182 S.....	2	99293.....	7,8
21657 X.....	1	31126 LF-8.....	8	31182 T.....	2	99299.....	5
21657 Y.....	6	31126 LF-16.....	8	31183.....	2	99300.....	5
22517.....	4,5,6	31130 A.....	7,8	31190 A.....	1		
22524.....	7,8	31130 B-8.....	7	31190 B.....	1		
22528.....	7,8	31130 B-12.....	7	31191.....	1		
22539 D.....	2	31130 B-16.....	7	31191 A.....	2		
22541 B.....	2	31130 F-12.....	7	31194.....	1		

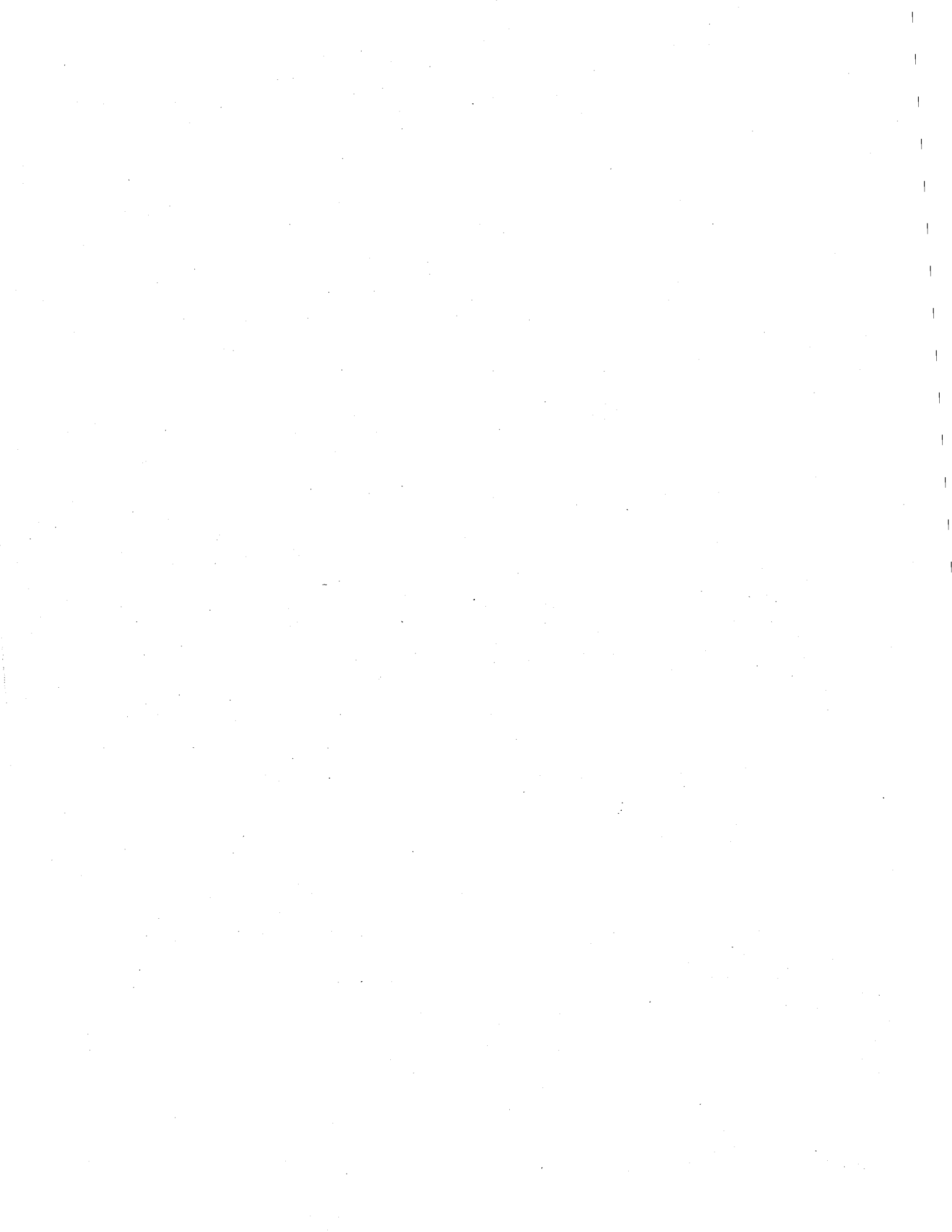

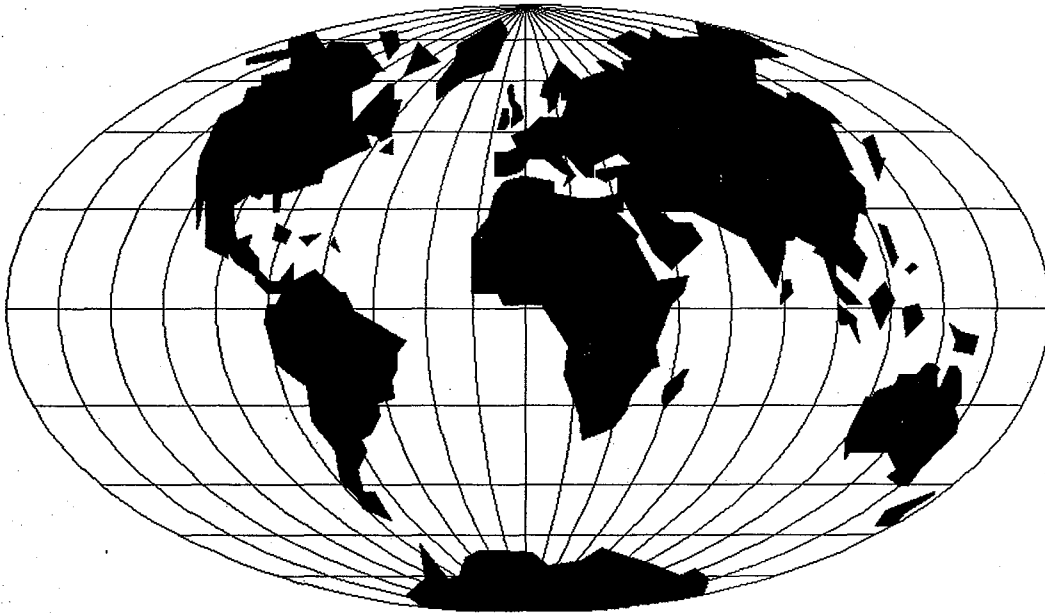

## WORLDWIDE SALES AND SERVICE

Union Special Corporation maintains sales and service facilities throughout the world. These offices will aid you in the selection of the right sewing equipment for your particular operation. Union Special Corporation representatives and service technicians are factory trained and are able to serve your needs promptly and efficiently. Whatever your location, there is a qualified representative to serve you.

---

**Corporate Office:** One Union Special Plaza  
Huntley, IL 60142  
Phone: 847•669•5101  
Fax: 847•669•1096

**European Distribution Center:** Union Special GmbH  
Raiffeisenstrasse 3  
D-71696 Möglingen, Germany  
Tel: 49•07141•247•0  
Fax: 49•7141•247•100

Brussels, Belgium  
Charlotte, N.C.  
El Paso, TX  
Hong Kong, China  
Huntley, IL  
Leicester, England  
Lille, France  
Miami, FL  
Milan, Italy  
Möglingen, Germany  
Montreal, Quebec  
Osaka, Japan  
Santa Fe Springs, CA

Other Representatives throughout  
all parts of the world.



*Union Special*  
INDUSTRIAL SEWING EQUIPMENT