

**SECOND
EDITION**



Union Special
INDUSTRIAL SEWING EQUIPMENT

CATALOG NO. 194-3

STYLES

30-210 30-230
30-220 30-410

LOCKSTITCH BLINDSTITCH MACHINES

Catalog No. 194-3

INSTRUCTIONS

FOR

ADJUSTING AND OPERATING

LIST OF PARTS

Styles

30-210

30-220
30-410

30-230

Second Edition

Copyright 1964

By

Union Special Corporation
Rights Reserved in All Countries

UNION SPECIAL CORPORATION

INDUSTRIAL SEWING MACHINES

CHICAGO

Printed in U.S.A.

May, 1981

IDENTIFICATION OF MACHINES

Each UNION SPECIAL LEWIS machine carries a style number, which, in this class of machines, is stamped in the style plate on the front of the column. The serial number of each machine is stamped in the main frame at the left upper main shaft bearing, under the head cover.

APPLICATION OF CATALOG

This catalog applies specifically to the styles of machines listed herein. All references to direction, such as right and left, forward and back, etc., are taken from the operators position while seated at the machine.

The operating direction of the handwheel is away from the operator.

DESCRIPTION OF MACHINES

High Production, Two Thread, Single Curved Needle, Lockstitch, Blindstitch, Cylinder Base Machine. Non-Skip 1 to 1 Stitch. Needle Shogs or Vibrates from Side to Side. Angle of Needle Penetration is in line of Feed. Calibrated Penetration Adjustment. Knee Lifter for Inserting and Removing Work. Work Support Plate. Maximum Work Space to Right of Needle 10 Inches.

30-210 For felling quarter, half or full linings of light weight material in men's suit coats and sport coats. Can also be used on women's high quality suit coats. Equipped with automatic plunger to stitch over pockets without closing pocket or missing a stitch. Side and lower feed. Stitching invisible on completed seams.

30-220 Same as Style 30-210 except equipped to sew medium weight material in men's topcoats and overcoats. Can also be used on women's high quality lined coats.

30-230 For felling medium weight suit coats and similar garments made with book seamed bottoms only, instead of binding or piping. Fells 3/16 inch from turned edge. Equipped with automatic plunger to stitch over pockets without closing pocket or missing a stitch. Stitching invisible on completed seam.

30-410 For felling quarter, half or full linings of extra light weight material such as tropicals in men's suit coats and sport coats. Can also be used on women's high quality suit coats. Equipped with automatic plunger to stitch over pockets without closing pocket or missing a stitch. Side and lower feed. Stitching invisible on completed seams.

NEEDLES

Use only genuine UNION SPECIAL needles. The needles are packaged under our brand name *Union Special*®. The recommended needle for the machines in Class 30 is Type 29 BB-090/036. It has a blade diameter of .036 inch (.90 mm). It is also available in the following sizes:

NEEDLE TYPE	SIZE	
	INCHES	MILLIMETERS
29 BB-075/029	.029	.75
29 BB-100/040	.040	1.00

Selection of proper needle size is determined by size of thread and weight of material used. Thread should pass freely through needle eye in order to produce a good stitch formation.

When sewing, immediately discard any needle which may have a hooked or blunt point.

To have needle orders promptly and accurately filled, an empty container, a sample needle, or the Type number should be forwarded. A complete order would read: "100 Needles, Type 29 BB-090/036".

SPEED

The recommended speed of these machines is 1500 R. P. M.

THREADING

Thread machines in accordance with threading diagram below.

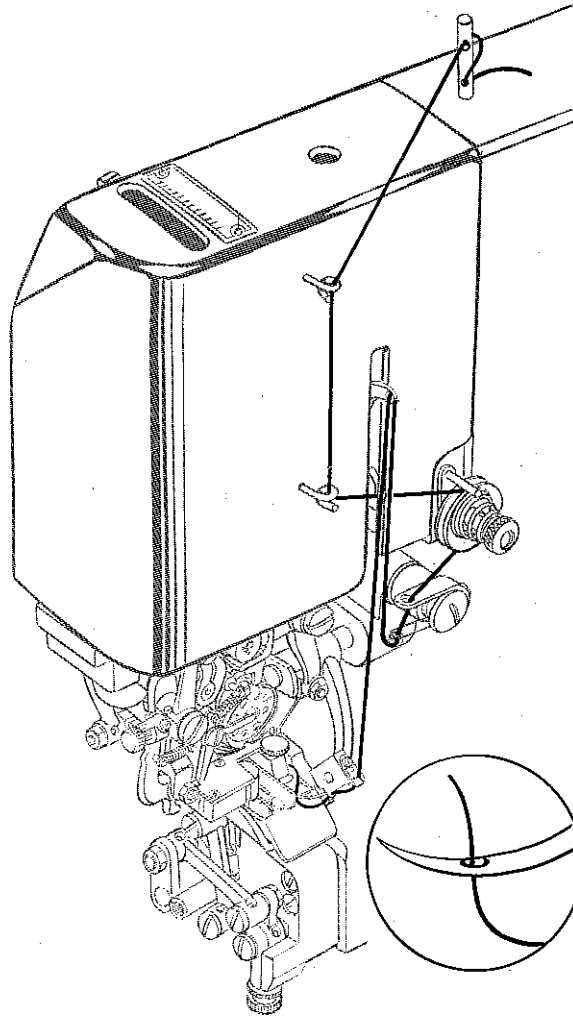

OILING

These machines should be oiled twice daily, before the morning and afternoon starts. Use a good grade of straight mineral oil of a Saybolt viscosity of 90 to 125 seconds at 100° Fahrenheit.

Most of the oiling places on these machines are readily identifiable because of the fact they are painted red. However, reference to the oiling diagram on page 5 will be beneficial.

Please note that it will be necessary to remove head cover, cylinder end cover, and to tilt the machine back from the sub-base to reach some of the oiling places.

Referring to the oiling diagram, it will be noted that there is a lubrication point marked "A". This point on the diagram refers to the cover over the hook driving gears, which are lubricated with a standard wheel bearing grease. Periodically, the cover should be removed and the grease replenished, if necessary.

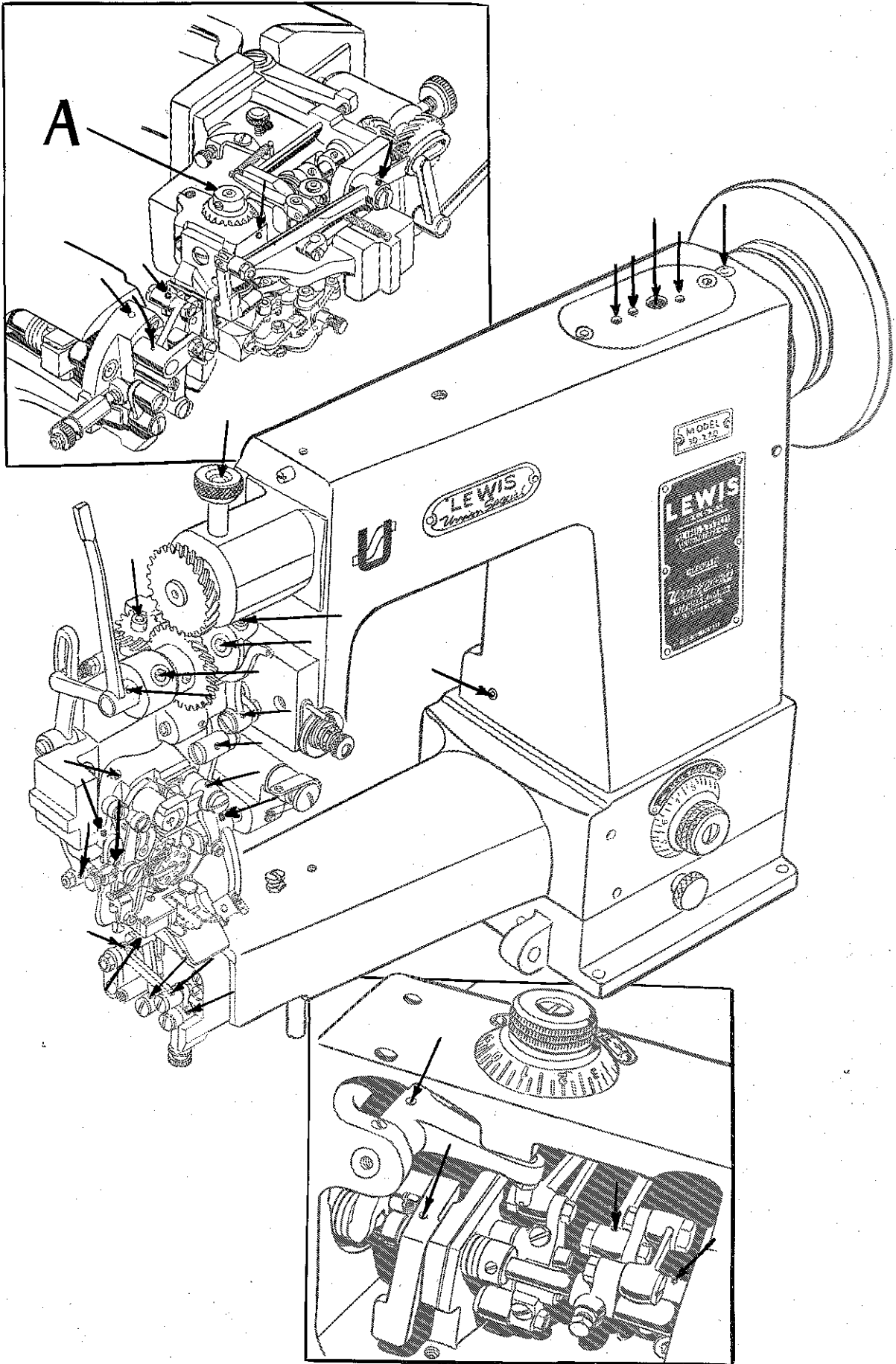

ORDERING REPAIR PARTS

ILLUSTRATIONS

This catalog has been arranged to simplify ordering repair parts. Exploded views of various sections of the mechanism are shown so that the parts may be seen in their actual position in the machine. On the page opposite the illustration will be found a listing of the parts with their part numbers, description and the number of pieces required in the particular view being shown.

Numbers in the first column are reference numbers only, and merely indicate the position of that part in the illustration. Reference number should never be used in ordering parts. Always use the part number listed in the second column.

Component parts of sub-assemblies which can be furnished for repairs are indicated by indenting their description under the description of the main sub-assembly. Example:

39	4115-72-4	Feed and Plunger Bearing Block, complete -----	1
40	16-352	Bushing -----	1
41	4121-3	Plunger Frame and Barrel Assembly -----	1
42	1306 L	Screw -----	1

It will be noted in the above example that the plunger bearing block is not listed. The reason is that replacement of this part individually is not recommended, so the complete sub-assembly should be ordered.

At the back of the book will be found a numerical index of all the parts shown in this book. This will facilitate locating the illustration and description when only the part number is known.

IDENTIFYING PARTS

Where the construction permits, each part is stamped with its part number. Part numbers represent the same part, regardless of catalog in which they appear.

USE GENUINE NEEDLES AND REPAIR PARTS

Success in the operation of these machines can be secured only with genuine UNION SPECIAL Needles and Repair Parts as furnished by the Union Special Corporation, its subsidiaries and authorized distributors. They are designed according to the most approved scientific principles, and are made with utmost precision. Maximum efficiency and durability are assured.

Genuine needles are packaged under our brand name *Union Special*®. This trademark is your guarantee of the highest quality in materials and workmanship.

TERMS

Prices are net cash and subject to change without notice. All shipments are forwarded f.o.b. shipping point. Parcel Post shipments are insured unless otherwise directed. A charge is made to cover postage and insurance.

ADJUSTING INSTRUCTIONS

REMOVING PLAY IN CONNECTING RODS

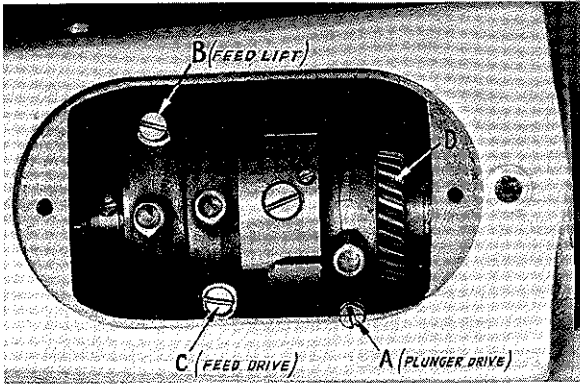

Fig. 1

Access to the connecting rod adjusting screws is through the opening in the top of the arm (Fig. 1). Remove screws and arm cover plate. Tighten screw (A) in plunger drive connecting rod until machine begins to bind while handwheel is being turned in the operating direction, which is away from the operator. Then loosen screw until machine turns freely. Repeat procedure for feed lift connecting rod and feed drive connecting rod, screws B and C respectively. Replace the cover plate and screws.

SETTING OSCILLATING (LEFT TO RIGHT) MOTION OF NEEDLE

Before timing the needle with lower plunger it is necessary to establish correct left to right movement of the needle. To set this properly turn handwheel away from operator until needle has completed its forward stroke on the right hand side. Loosen set screws in gear (A, Fig. 2) and rotate needle vibrating cam (A, Fig. 3) until slot is in a horizontal position below center. Retighten set screws in gear.

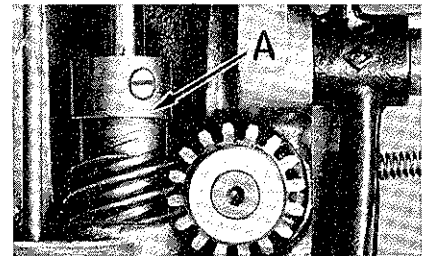

Fig. 2

After this adjustment has been made, rotate handwheel until needle eye is at the center of projection of the needle guide on the left hand side. At this point needle should make slight contact with projection. In order to position needle accordingly loosen screw (B, Fig. 3) and tap block (C) left or right. Retighten screw.

TIMING NEEDLE WITH LOWER PLUNGER

Check the adjustment by turning handwheel slowly in the operating direction and note carefully when plunger is raised to its highest point and comes to a full stop that the needle is approximately $3/16$ inch from the plunger and is about to enter the cloth side as the needle makes the right hand penetration.

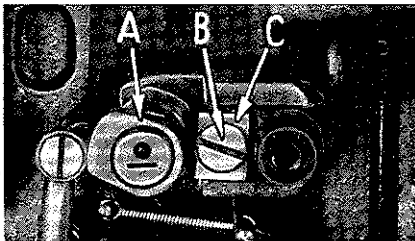

Fig. 3

remove gear from shaft.

Loosen screws (A, Fig. 4) in main shaft head driving gear (B) and

In timing, turn the handwheel slowly away from you and watch the movement of the plunger. You will note that on every second revolution of the handwheel the plunger is raised to its highest point. When the plunger is raised to its highest point and comes to a stop, the groove or slot in the main shaft will be on top. Maintain this position while timing the needle to the plunger, which is accomplished by turning gear (C, Fig. 4). Turn gear toward operator until the needle has raised to its highest point and is again moving toward the plunger on the right hand side of the guide. When the point of the needle is within approximately $3/16$ inch of

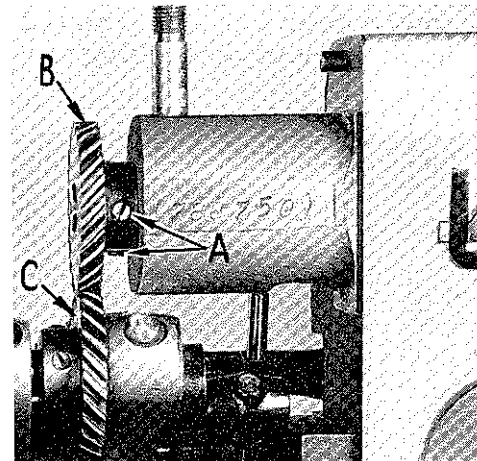

Fig. 4

ADJUSTING INSTRUCTIONS (Continued)

the center of plunger insert main shaft gear (B) in position on the shaft and tighten pointed spot screw in the groove of the main shaft; also tighten set screw in gear.

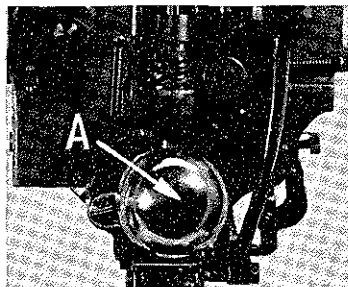

Fig. 5

You will note that the left hand penetration of needle is into the lining and at this time the lower plunger does not raise high enough to meet the needle. Therefore, the timing of the needle and plunger can only be accomplished on right hand penetration of needle. You will also note that the movement of needle bar is from side to side on every other penetration of the needle, which is necessary in joining the lining to body of garment. In case the plunger itself gets out of time, it may be retimed through the plunger pinion (D, Fig. 1) on the main shaft. The plunger is set correctly if the LOWEST point to which the plunger descends is the same on two consecutive revolutions of the handwheel.

NOTE: The plunger must be at its highest point and stationary while needle penetrates the material. After the stitch is completed the plunger descends and material moves forward.

TIMING HOOK WITH THE NEEDLE

If thread breakage occurs, the most probable cause is incorrect timing of the hook. To properly time the hook, the following procedure must be carefully followed.

Remove hook gear cover (A, Fig. 5) at the back of the machine. Turn the handwheel in the operating direction until needle starts its penetration stroke on the left side. Continue turning the handwheel until the needle has completed its forward stroke and has returned $3/32$ inch. The hook point should be directly over the center of the needle. Should it be necessary to move the hook, loosen set screws (A, Fig. 6) in the upper gear and rotate hook until hook point is over the center of needle. Retighten screws. Note the timing marks (B) on the upper and lower gears. The two marks, one on each gear, should be opposite each other. The gears are marked so that after correct timing has been achieved, the lower gear can be removed for cleaning or the removal of fouled-up thread from the hook without disturbing the hook - needle setting.

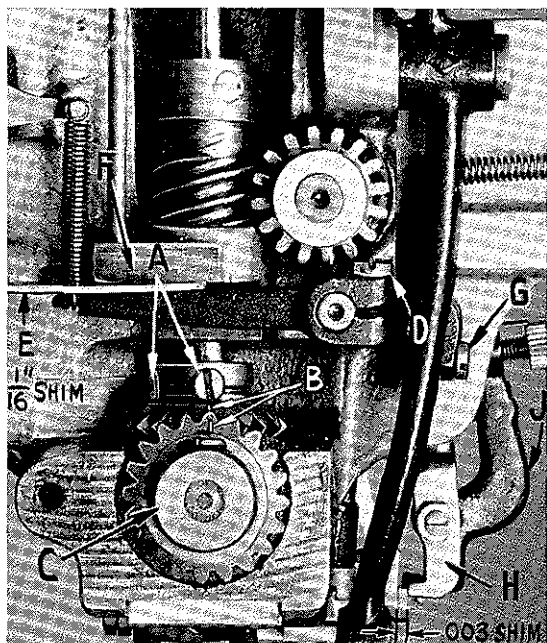

Fig. 6

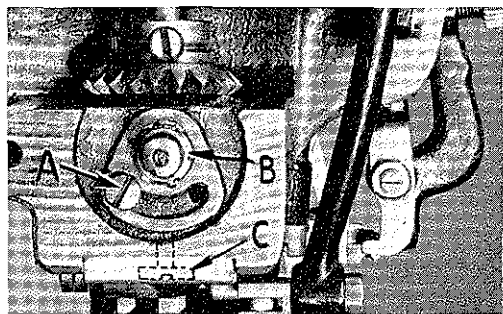

Fig. 7

NOTE: To eliminate incorrect settings due to backlash in hook timing mechanism, backlash should be taken up by turning hook gear (C, Fig. 6) in clockwise direction.

SETTING THE HEIGHT OF HOOK

The hook height is relative to the needle and generally adjustment is not necessary as it is set at the factory. The hook point should be set .005 to .010 inch above the needle. Change in needle size will require resetting of the hook.

ADJUSTING INSTRUCTIONS (Continued)

To change the height of the hook, remove lower gear (C, Fig. 6). This will expose screw (A, Fig. 7) that holds the hook shaft bushing (B) in position through the flange of the bushing. This bushing is eccentric and turning it will change the height of the hook. A second screw hole is provided for additional adjustment by merely removing screw (A) and placing it in this hole. After proper height is obtained, tighten screw. Place lower gear on hook shaft, lining up the two timing marks and tighten screws. Use lower gear to take up any end play in the hook shaft.

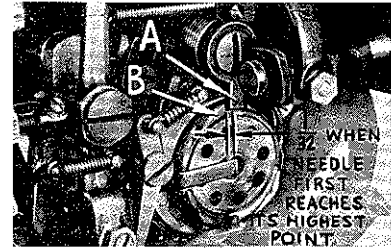

Fig. 8

TIMING THE BOBBIN CASE RELEASE

The bobbin case release is timed correctly if there is a $1/32$ inch clearance between the release lever (A, Fig. 8) and bobbin case (B), when the release lever has traveled its full stroke to the left and the backlash in the hook has been taken up to the left. To adjust the opener, turn handwheel in operating direction until the release lever has traveled its full stroke to the left. Loosen screw (A, Fig. 9) in bobbin case release lever and turn opener to obtain the $1/32$ inch clearance. Tighten screw.

FEED ADJUSTMENT

The lower or bottom feed is set at the factory and no further adjustment should be necessary. However, if for any reason

the lower feed must be changed, refer to the instructions covering the setting of bottom feed point.

*SETTING BOTTOM FEED POINT HEIGHT

Turn handwheel in operating direction until the feed point reaches its highest position and the feed plate reaches its lowest position. At this point, there should be from $3/32$ to $1/8$ inch space between the top of the feed plate and the bottom of the presser foot (Fig. 9). To obtain this adjustment, loosen the machine base locking screw (A, Fig. 10) and lay the machine on its back. Then, loosen screw (A, Fig. 11) and hold the link (B, Fig. 9) so that the feed point is pressed up against the bottom of the presser foot. Turn the handwheel in operating direction until the feed point reaches its most forward position, and retighten the screw (A, Fig. 11).

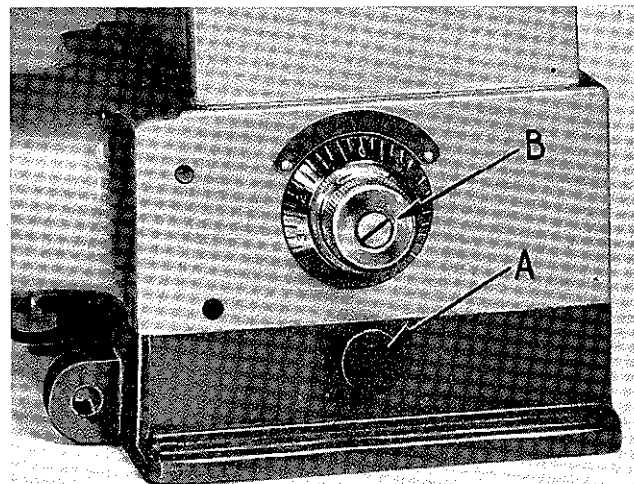

Fig. 10

ADJUSTING INSTRUCTIONS (Continued)

SETTING BOTTOM FEED POINT IN LINE OF FEED

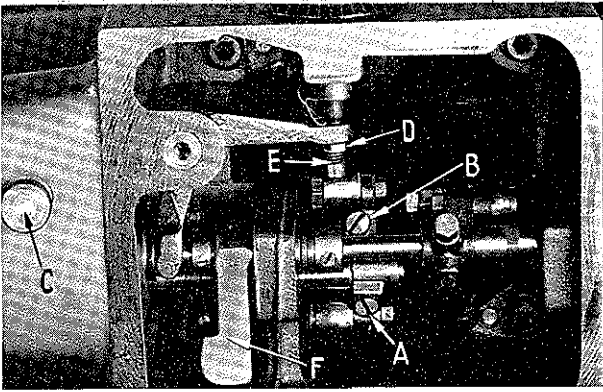

Fig. 11

Turn the handwheel in operating direction until the feed point first touches the presser foot. At this point, the front edge of the feed point should be aligned with the front edge of the knurling on the feed plate. To make this adjustment, loosen screw (B, Fig. 11) and, by means of the link (A, Fig. 12), move the feed point forward or backward as required. Retighten screw (B, Fig. 11). If, in this adjustment, the feed point has to be moved an appreciable distance, repeat the adjustment "Setting Bottom Feed Point Height" in the previous instructions.

SETTING THE FEED PLATE HEIGHT AND PRESSURE

Turn handwheel in operating direction until the feed point has reached the lowest point of its travel. At this position, there should be no play between the feed plate and the presser foot.

To make this adjustment, loosen screw (B, Fig. 12) and, with the right hand, hold the feed plate against the presser foot. Then, by holding the feed link (A) with the left hand, push the feed point down until there is 1/32 inch clearance between the block (C) and the plunger bearing block (D). Then, retighten screw (B).

The feed plate pressure is adjusted at the factory.

If it becomes necessary to change the pressure, turn the knurled screw (C, Fig. 11) clockwise for more pressure and counter clockwise for less pressure, referring to Fig. 11

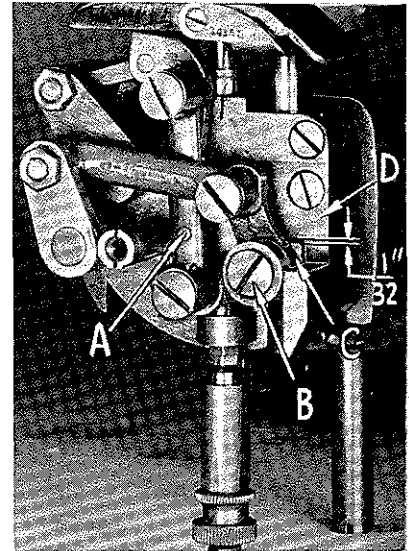

Fig. 12

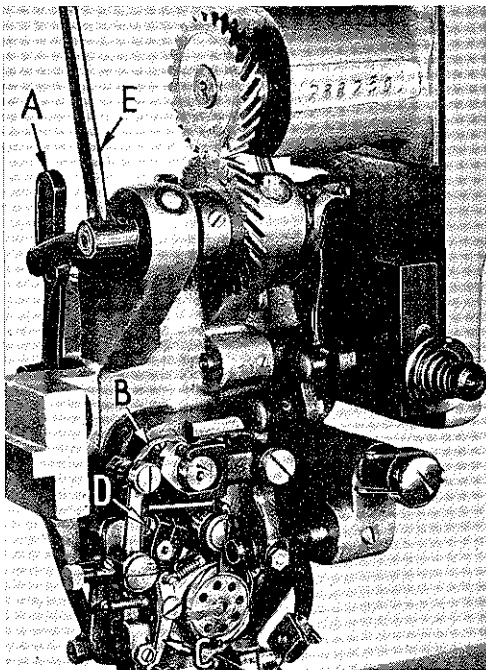

Fig. 13

SETTING THE LINING FEED

To set the lining feed point correctly, it is necessary to synchronize the motion of lining feed rocker lever (A, Fig. 13) and lining feed cam (B). Turn handwheel in operating direction until slot in needle vibrating cam is in vertical position to the right of center (A, Fig. 14). Loosen screws in lining feed cam (B) and turn feed cam until follower roller (C) is in center of high lobe of cam. Retighten screws. With machine in this position loosen screw (D, Fig. 6) in crank lever. Place a 1/16 inch shim (E) between lever and lug (F) on head. Press lining feed point against presser foot and tighten binder screw. Check feed motion by turning handwheel in operating direction. The feed point motion, when adjusted correctly, will travel a rectangular path.

LINING CLAMP

The lining clamp opening lever (C, Fig. 13) must be adjusted so that when the lining feed is in light contact with the presser foot on the beginning of feeding stroke, the point of the lining clamp lever is in light contact with the lining clamp (Fig. 13). Adjust by loosening the binder screw (D, Fig. 13).

The object of this lever and adjustment is to automatically release the lining clamp on the feeding stroke of the upper feed which avoids any pressure being applied to the lining.

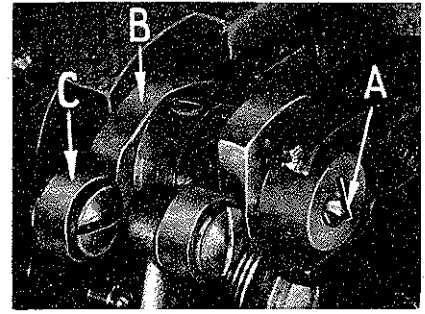

Fig. 14

TIMING NEEDLE WITH LINING PLUNGER

The lining plunger mechanism, which operates the lining plunger (A, Fig. 15) is designed so that the plunger will recede slightly before the needle penetrates the fabric.

The reason for this can be understood more clearly if reference is made to the sketches below.

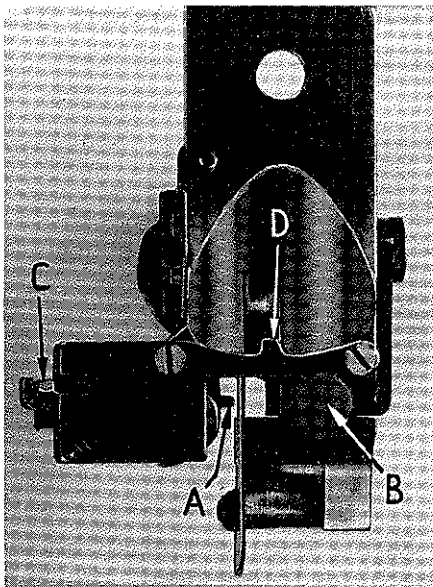
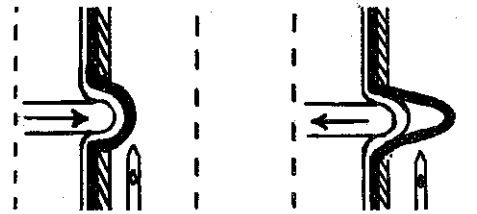

Fig. 15



Sketch A

Sketch B

You will note in sketch A on the right or in-stroke of the plunger, both plies of lining are stretched over the plunger. If the needle were to penetrate at this time, both plies would be penetrated. Therefore, the timing of the lining plunger to the needle must be set so that penetration takes place while the plunger is receding and the plies of lining are separating, as in sketch B.

To accomplish this setting turn handwheel in operating direction until needle is on the down stroke on the left side and the point of needle is approximately 1/32 inch from the center of lining plunger. Now, loosen screws in lining plunger cam (A, (Fig. 16) and rotate cam in counterclockwise direction until follower roller (B) is just leaving high lobe. (Examine contact surface of cam and note high lobe; it appears as a raised flat about 1/16 inch long). Retighten screws in the cam.

With machine in this position, loosen the binder screw (G, Fig. 6) in the lining plunger yielding crank lever and place a .003 inch shim between the lining plunger adjusting lever (H, Fig. 6) and the presser foot. Apply pressure at (J) and retighten binder screw.

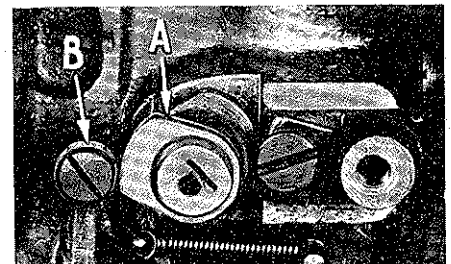

Fig. 16

SETTING THE HEIGHT OF BOTTOM PLUNGER

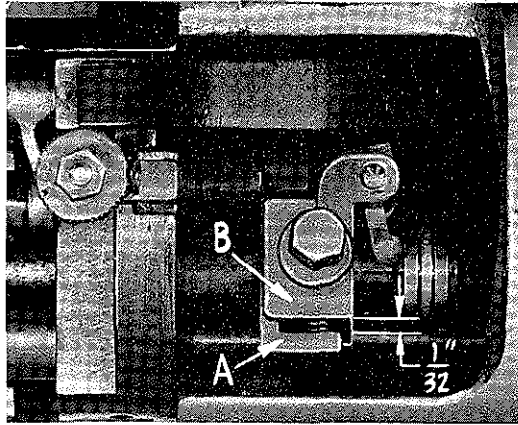

Fig. 17

The height of the bottom plunger is adjusted by turning knob (B, Fig. 10) clockwise to raise the plunger and counterclockwise to lower it. To provide for the maximum plunger adjustment, there should be 1/32 inch clearance between the plunger crank (A, Fig. 17) and plunger block (B) when the adjusting knob (B, Fig. 10) is turned clockwise as far as it will go. Note that there are pins which stop the knob (B) after each complete revolution. The knob may be pulled out toward the operator to lift it over the stop. The knob can make three complete revolutions. To make the 1/32 inch adjustment, turn the knob clockwise as far as it will go. Loosen the lock

nut (D, Fig. 11) and turn screw (E) in the required direction. Retighten nut (D).

ADJUSTING LENGTH OF STITCH

Stitch length adjustment is made through the hole in the top of arm (Fig. 18). (NOTE: The cover has been removed from the arm). Turn the handwheel in the operating direction until the lock screw (A, Fig. 18) and adjustment screw (B) are in view. Loosen the lock screw and turn the adjustment screw in the required direction. Turning the screw clockwise shortens the stitch and counterclockwise lengthens it. Retighten the lock screw (A) and replace top cover.

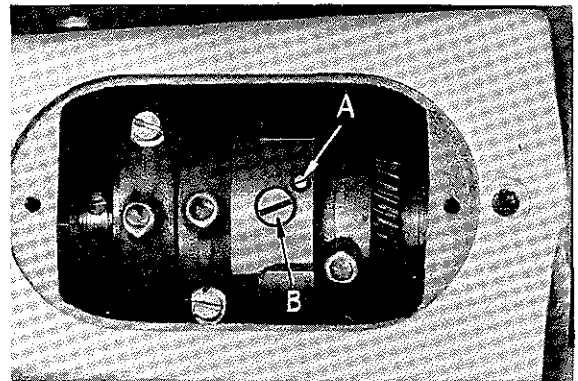
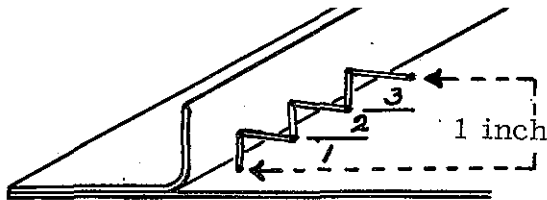

Fig. 18

Changing the bottom feed length will require a compensating adjustment of the lining feed. The lining feed is controlled by lever (E, Fig. 13). Moving lever away from operator lengthens lining feed, moving it toward operator shortens feed. Maximum stitch length is 2 S. P. I., for all Styles except Style 30-230 which is 3 S. P. I., measured as indicated on sketch.



It has been found to be advantageous to set the lining feed to its maximum length, and then set the bottom feed to obtain the desired fullness in the lining. The setting should be done preferably on garments where maximum fullness of lining is desired.

INSERTING BOBBIN IN HOOK

Turn the handwheel in the operating direction until the needle is at its highest point of travel away from the bobbin case.

Open the bobbin case latch (A, Fig. 19) and insert bobbin (B) so that the thread will come off the bottom of the bobbin in the direction of the case tension spring (C) and through the slot (D) in the bobbin case. Leave three or four inches of thread outside the bobbin case. Close bobbin case latch. The tension on the bobbin thread is controlled by turning screw (E) in the required direction. For easier access to this screw, have the needle in its highest position.

ADJUSTING INSTRUCTIONS (Continued)

NOTE: We suggest, for a new operator, that the needle thread be held lightly in the hand and the handwheel turned until the first stitch is completed, which will draw the bobbin thread underneath the tension spring.

CAUTION: Do not run the machine without material underneath the presser foot unless the feed point is out of contact with the foot and the needle thread is out of the needle.

THREAD CONTROL

Check to be sure the machine is threaded in accordance with the threading diagram on page 4, and sew machine under power to check stitch. If hook is not catching the needle thread as a result of the needle not throwing up a large enough loop, the needle carrier should be adjusted. To make this adjustment, turn the handwheel in the operating direction until the needle carrier is in its highest position, and, with a wrench, loosen nut (A, Fig. 20) and turn the needle stud (B) in the required direction. By means of this stud, moving the needle point toward the hook will enlarge the loop. This of course, changes the previous 3/32 inch setting of the hook point to needle. However, at times this will be necessary because of peculiarities of thread or material.

If the needle thread snaps as it passes over the top of the bobbin case, this is an indication that either the tension on the needle thread check spring (C) is too great or that the hook opener is too slow or fast. If the tension on the check spring is not great enough, the needle thread will not come off the hook fast enough with the result that the hook will pick up the needle thread a second time, causing the machine to break thread. To make this adjustment, turn the thread controller staff (D) in the required direction.

Thread breakage may also result if the needle tension is set either too loose or too tight. The tension on the needle thread is regulated by turning tension nut (E) to the right or left as required. This tension should be set sufficiently to produce the proper stitch. Do not, however, make this adjustment too tight, as the thread will draw the material and leave impressions or dimples on the face of the garment.

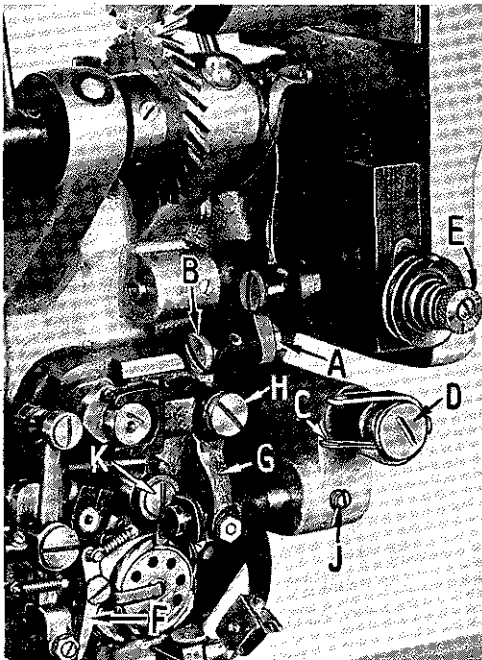

Fig. 20

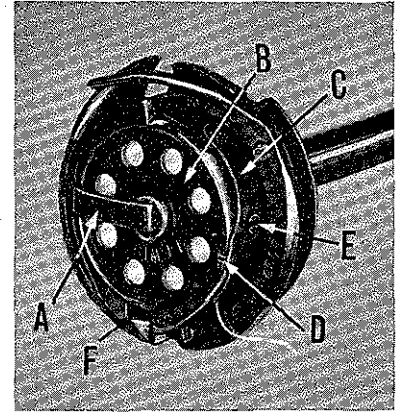

Fig. 19

ADJUSTING AUTOMATIC PLUNGER

Machines in this class are equipped with an automatic plunger to insure a uniform depth of needle penetration when felling across parts of a garment where there is considerable variation in thickness.

Below the regular or work presenting plunger, which is in the plunger barrel (A, Fig. 21) is the automatic plunger (B).

To adjust the automatic plunger in relation to the bottom plunger, back off the crown adjusting screw (B, Fig. 15) on the presser foot. Loosen knurled adjusting nut (C, Fig. 21) so that the

ADJUSTING INSTRUCTIONS (Continued)

automatic plunger (B) does not contact the bottom plunger at any time. Set the penetration knob (B, Fig. 10) so that the bottom plunger is high enough to cause the needle to penetrate the material to the proper depth. Then, turn the penetration knob about 2 or 3 notches higher. With the bottom plunger at low position, turn the knurled adjusting nut (C, Fig. 21) until the distance between the lower nut (D), on the bottom plunger, and the automatic plunger (B) is $\frac{1}{32}$ inch.

Turn the crown screw (B, Fig. 15) down, and test the screw to see that when a pocket or pleat is crossed the amount of needle penetration remains the same.

REMOVING PRESSER FOOT

Do not change the presser foot until you have carefully noted the relative position of the various parts which operate in conjunction with the presser foot in order that you may be able to reassemble the relating parts correctly.

To remove presser foot, lay the machine back on the table. Turn handwheel until the plunger is at its lowest point. Loosen screw (C, Fig. 7) which holds the foot to the head of the machine. Lower feed plate by pressing hand against feed depresser yoke (F, Fig. 11). This releases the foot.

In replacing the foot be sure to see that lining feed (C, Fig. 9) is properly inserted in the left side of the foot, and that the point of the lining clamp depresser lever (F, Fig. 20) is at the right of the lug (C, Fig. 15) on the lining clamp.

Also see that the groove of the bobbin case is in line with the lug on bobbin case retainer (D, Fig. 15).

REMOVING THE HOOK

Remove the needle from the machine. Also remove the presser foot, referring to instructions on "Removing the Presser Foot". Remove needle bar vibrating link (G, Fig. 20) by loosening the screw (H). Loosen screw (J) and remove needle bar shaft: this in turn releases the needle carrier, so that it may be raised to allow removal of hook.

Remove bobbin case release by loosening and removing screw (K, Fig. 20). Remove lower gear (C, Fig. 6) by loosening the set and spot screws which hold the gear on the shaft.

The hook may now be withdrawn from the machine. In reassembling, reverse the above instructions, noting carefully that all parts are replaced in their proper position. If a new hook is put in the machine it should be timed with the needle; refer to instructions on "Timing the Hook".

TENSION RELEASE ON NEW MACHINES

The tension release should be positioned so that it does not separate the tension discs until the knee press is activated. This adjustment is made by loosening the screw on top of the bracket under the head cover. After adjustment is made retighten screw.

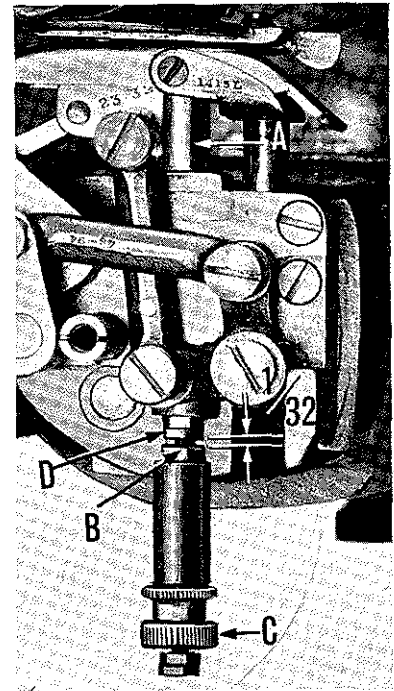
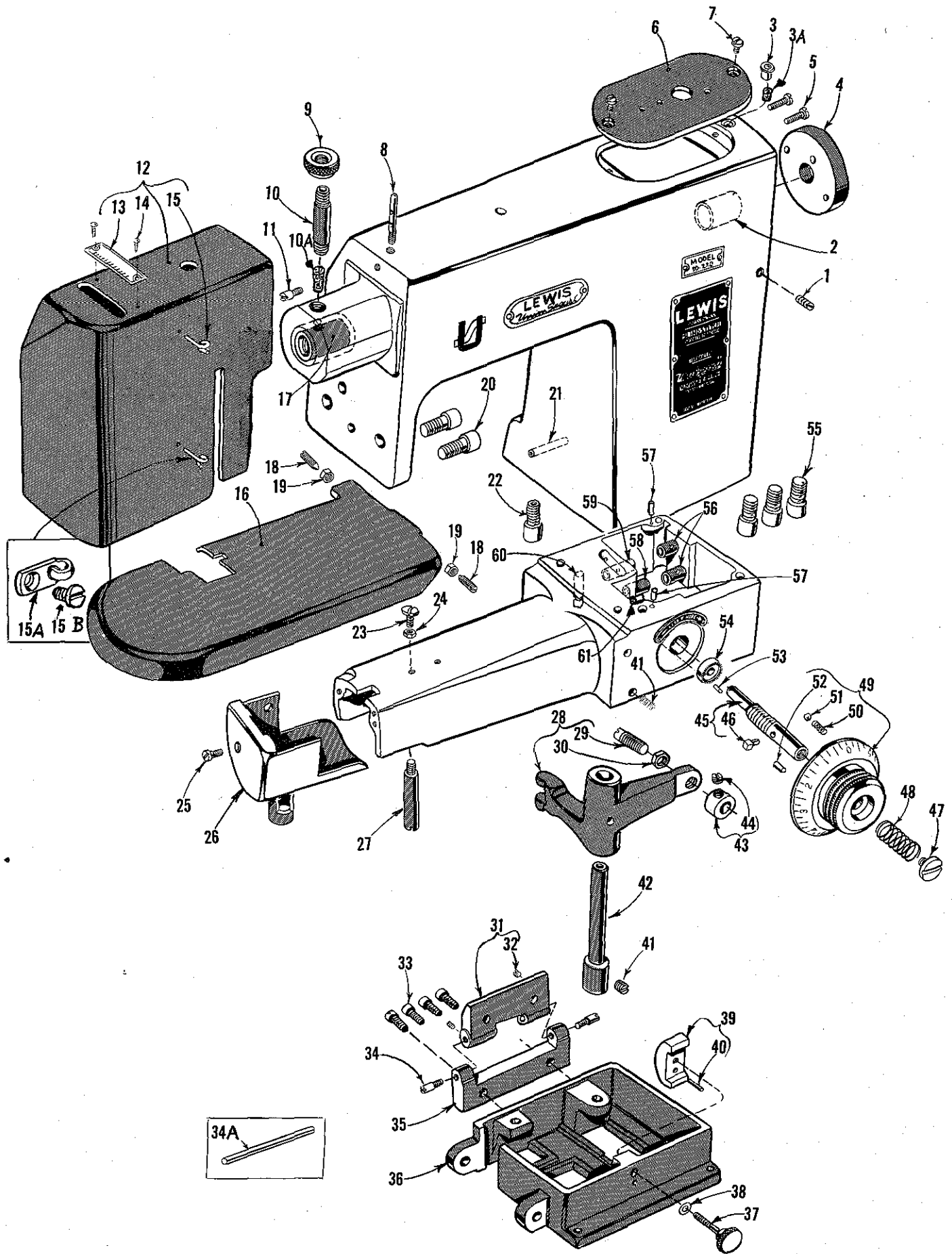

Fig. 21

EXPLODED VIEWS
AND
DESCRIPTION OF PARTS
FOR
CLASS 30 MACHINES



MAIN FRAME, BUSHINGS, COVERS AND MISCELLANEOUS PARTS

<u>Ref. No.</u>	<u>Part No.</u>	<u>Description</u>	<u>Amt. Req.</u>
1	CS320-1/2	Set Screw, for No. 16-277 -----	1
2	16-368	Bushing, right -----	1
3	125-23	Oil Cup -----	1
3A	666-65	Oil Wick, for Main Shaft Bushing, right -----	1
4	39-128	Collar -----	1
5	18-957	Screw -----	2
6	432-278	Arm Cover -----	1
7	18-596	Screw -----	2
8	41-55	Thread Guide -----	1
9	20-134	Nut -----	1
10	61-79	Oil Tube -----	1
10A	666-163	Oil Wick, for Main Shaft Bushing, left -----	1
11	18-903	Screw, for supporting head cover -----	1
12	432-280	Head Cover, complete -----	1
13	110-358	Plate -----	1
14	18-1037	Drive Screw -----	2
*15	147-10	Eyelet -----	2
15A	63470 A	Eyelet, used on new machines -----	2
15B	22564 D	Screw -----	2
16	4-136	Work Support Plate -----	1
17	416-367	Bushing, complete -----	1
18	LS398	Screw -----	2
19	LS299	Nut -----	2
20	18-1045	Screw, for No. 1-67 -----	2
21	61-75	Oil Tube -----	1
22	18-1046	Screw -----	1
23	FP505	Adjusting Screw, for No. 4-136 -----	1
24	1160 L	Nut -----	1
25	CS313	Screw -----	1
26	32-276	Cylinder End Cover -----	1
27	17-167	Stud, for supporting machine -----	1
28	48-166	Plunger Regulating Bell Crank, large -----	1
29	1192 L	Adjusting Set Screw -----	1
30	20-34	Lock Nut -----	1
31	50-263 L	Cylinder Base Hinge Bracket -----	1
32	1081 L	Set Screw -----	2
33	18-998	Screw -----	4
‡34	18-959	Hinge Bracket Pivot Screw -----	2
34A	14-508	Hinge Bracket Shaft -----	1
35	50-262	Sub-Base Hinge Bracket -----	1
36	3-91	Sub-Base -----	1
37	18-1030	Sub-Base Locking Latch Screw -----	1
38	40-139	Washer -----	1
39	51-26	Sub-Base Locking Latch -----	1
40	22-C214-2	Pin -----	1
41	1005 L	Set Screw, for No. 14-472 -----	1
42	14-472	Plunger Regulating Bell Crank Shaft -----	1
43	1173 L	Collar, for No. 418-1026 -----	1
44	1137 L	Set Screw -----	1
45	418-1026	Plunger Regulating Screw, complete -----	1
46	22-296	Pin -----	1
47	18-1028	Screw -----	1
48	21-404	Spring -----	1
49	4149-30	Plunger Regulating Knob Assembly -----	1
50	21-237	Spring -----	1
51	79-31	Ball -----	1
52	22-C214-4	Stop Pin -----	1
53	22-C214-4	Stop Pin -----	1
54	44-301	Notched Disc Plate -----	1
55	18-1045	Screw, for No. 2-116 (Arm) -----	3
56	1321 L	Plunger Rocker Shaft Bushing -----	2
57	22-148	Dowel Pin -----	2
58	16-356	Bushing, for Feed Elevating Rocker Shaft -----	1
59	16-354	Bushing, for Feed Rocker Shaft -----	1
60	1055 L	Pin -----	1
61	16-379	Plunger Rocker Shaft Bushing, on new machines -----	1

*NOTE: On new machines No. 147-10 will be replaced by one each Nos. 63470 A and 22564 D.

‡NOTE: On new machines two No. 18-959 will be replaced by one No. 14-508.

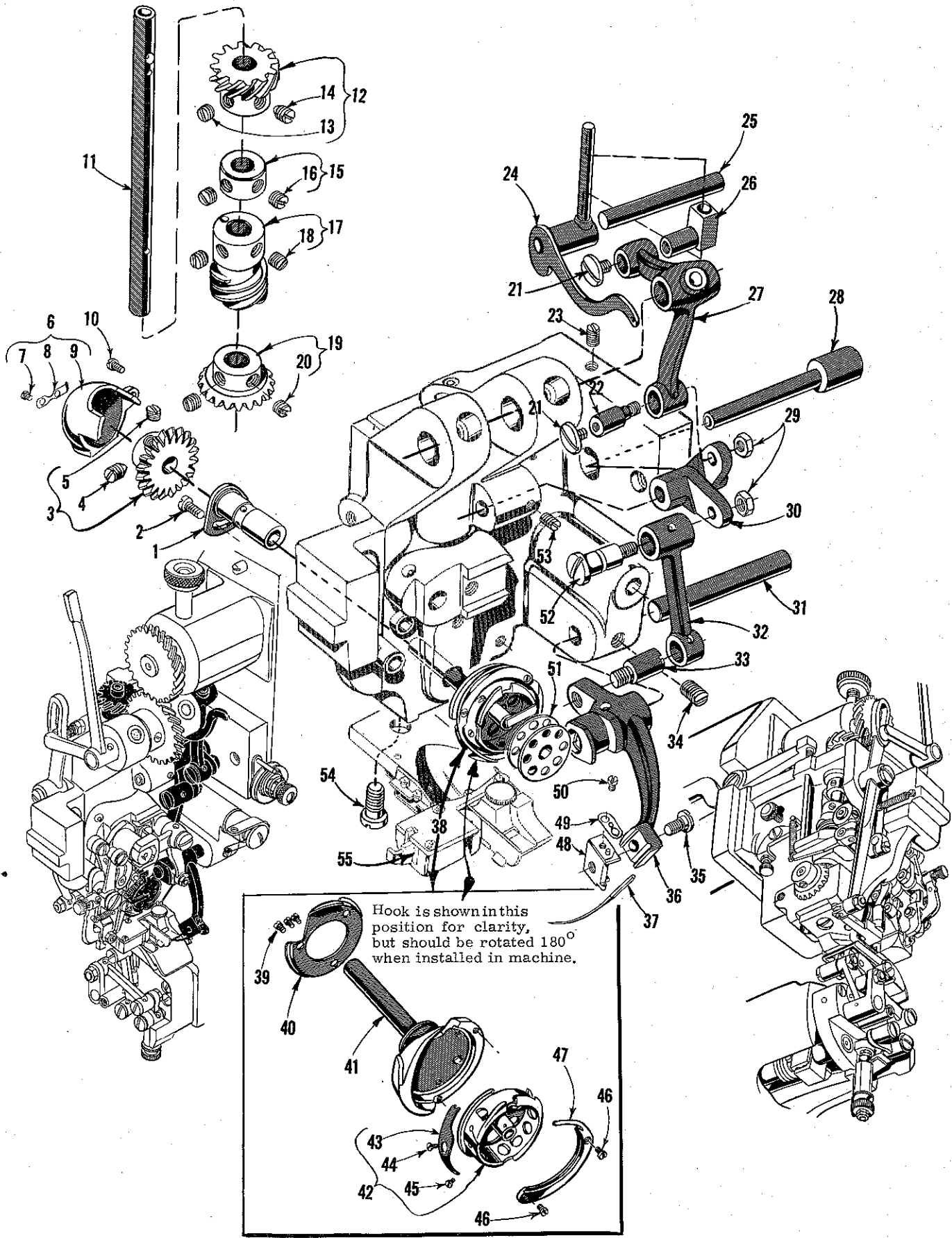

ROTARY HOOK, NEEDLE CLAMP, THREAD TAKE-UP,
AND NEEDLE DRIVING PARTS

Ref. No.	Part No.	Description	Amt. Req.
1	416-10	Adjustable Hook Bushing, complete-----	1
2	18-227	Clamp Screw-----	1
3	1030 L	Hook Driven Gear -----	1
4	1031 L	Spot Screw -----	1
5	1029 L	Set Screw-----	1
6	1791 AL	Hook Gear Cover, complete -----	1
7	1075 L	Screw -----	1
8	1797 L	Clip -----	1
9	1791 L	Hook Gear Cover -----	1
10	LS314	Screw -----	1
11	1764 L	Hook Timing Shaft -----	1
12	1761 L	Hook Shaft Driving Gear -----	1
13	1029 L	Set Screw -----	1
14	1031 L	Spot Screw -----	1
15	1027 L	Collar -----	1
16	1029 L	Set Screw -----	2
17	1762 L	Needle Carrier Vibrating Worm Gear -----	1
18	1025 L	Set Screw -----	2
19	1028 L	Hook Shaft Driving Gear -----	1
20	1025 L	Set Screw -----	2
21	888 L	Screw -----	2
22	18-902	Eccentric Screw -----	1
23	1022 L	Set Screw, for No. 1019 L -----	1
24	445-235	Take-up Lever, complete -----	1
25	1019 L	Take-up Lever Shaft -----	1
26	887 L	Take-up Lever Slide Block -----	1
27	1712 L	Needle Carrier Connecting Rod, upper-----	1
28	14-426	Needle Bell Crank Shaft-----	1
29	1160 L	Nut -----	2
30	1710 L	Needle Bell Crank -----	1
31	1708 L	Needle Carrier Shaft-----	1
	* 17-175	Needle Carrier Shaft-----	1
	* 16-382	Slip Bushing, for needle carrier shaft -----	1
32	1709 L	Needle Carrier Connecting Rod, lower-----	1
33	1707 L	Screw, for No. 118-31 -----	1
34	1003 L	Set Screw, for Nos. 17-175 or 1708 L -----	1
35	1706 L	Screw, for No. 1705 AL -----	1
36	118-31	Needle Carrier -----	1
37		Needle -----	1
38	906 A-1 L	Hook, complete with bobbin case -----	1
39	1036 L	Guard Screw -----	3
40	1035 L	Needle and Thread Guard -----	1
41	905 AL	Hook, with shaft -----	1
42	1041 AL	Bobbin Case, complete -----	1
43	1043 L	Tension Spring -----	1
44	1046 L	Tension Screw -----	1
45	18-912	Screw -----	1
46	1039 L	Screw -----	2
47	1037 L	Hook Gib -----	1
48	1705 AL-1/2	Needle Clamp, with pin -----	1
49	147-22	Needle Thread Eyelet -----	1
50	1036 L	Screw, for needle thread eyelet-----	1
51	1047 L	Bobbin -----	1
52	1711 L	Bearing Screw -----	1
53	LS330	Set Screw, for No. 14-426-----	1
54	876 L	Screw, for presser foot-----	1
55		Presser Foot (See Page No. 31)-----	1

* Not furnished with machine, order as extra send and charge item.

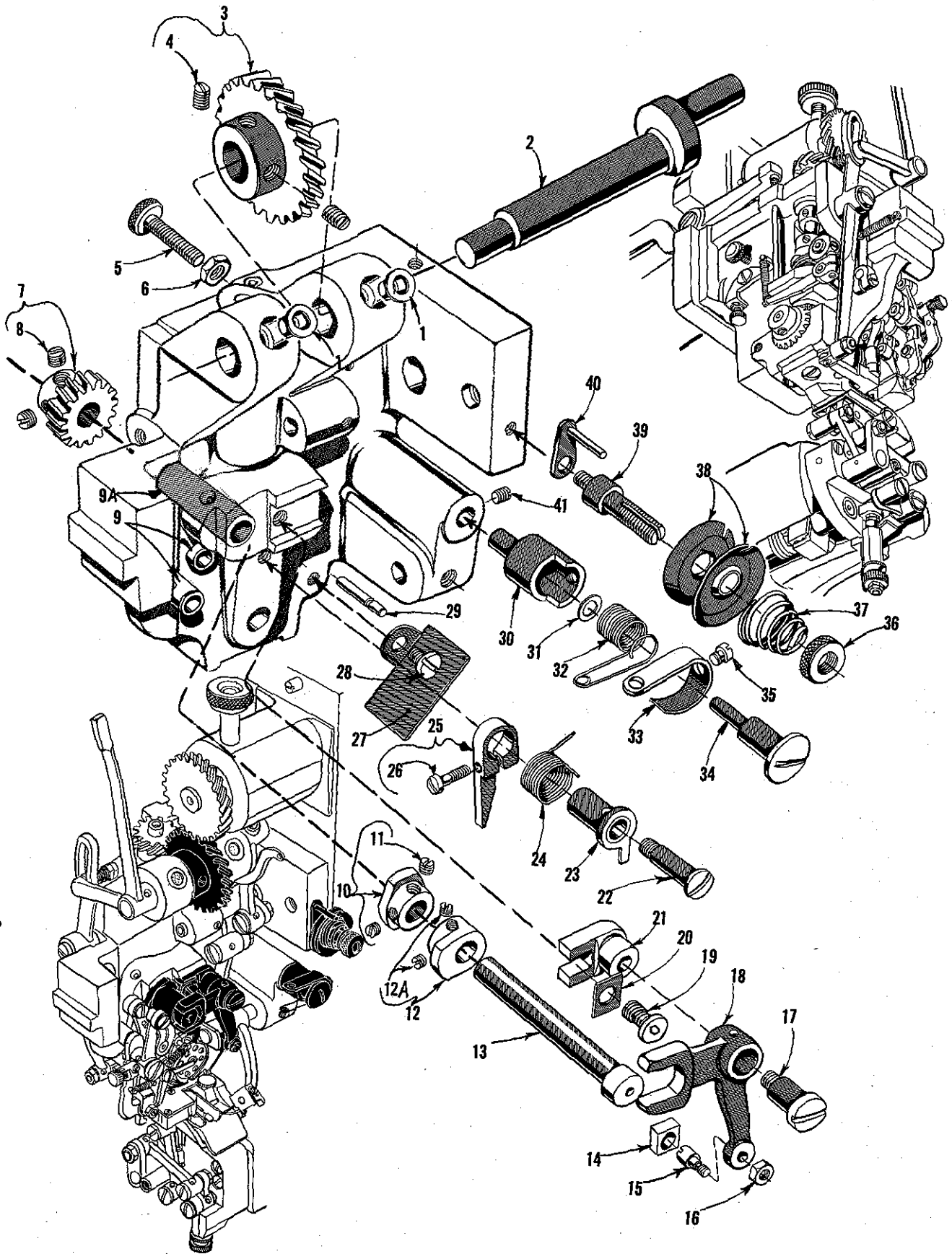

THREAD TENSION, BOBBIN RELEASE AND NEEDLE BAR VIBRATING PARTS

<u>Ref. No.</u>	<u>Part No.</u>	<u>Description</u>	<u>Amt. Req.</u>
1	125-23	Oil Cup-----	2
2	15-21	Head Main Shaft, for Styles 30-210, -220, -410-----	1
	1702 L	Head Main Shaft, for Style 30-230-----	1
3	1703 L	Head Main Shaft Driven Gear-----	1
4	1005 L	Set Screw-----	2
5	18-844	Screw, for adjusting head cover-----	1
6	1160 L	Nut-----	1
7	1763 L	Needle Carrier Vibrating Worm Gear-----	1
8	1025 L	Set Screw-----	2
9	1735 L	Bushing, for top plunger and top feed yielding crank----	2
9A	16-383	Bushing, for Needle Carrier Vibrating Crankshaft-----	1
10	1739 SL	Top Feed Cam-----	1
11	1022 L	Set Screw-----	2
12	34-28	Cam, for top plunger on Styles 30-210, 30-220, 30-410-	1
	34-9	Cam, for top plunger on Style 30-230-----	1
12A	1022 L	Set Screw-----	2
13	1718 L	Needle Carrier Vibrating Crankshaft-----	1
14	69-18	Needle Carrier Vibrating Crank Slide Block-----	1
15	17-137	Stud-----	1
16	1311 L	Nut-----	1
17	782 L	Bearing Screw-----	1
18	46-146	Needle Carrier Vibrating Link-----	1
19	18-1094	Screw-----	1
20	1719 L	Washer-----	1
21	1717 L	Needle Bar Vibrating Crank Adjusting Lug-----	1
22	1795 L	Bearing Screw-----	1
23	1794 AL	Bobbin Case Release, complete-----	1
24	914 L	Bobbin Case Release Spring-----	1
25	915 L	Bobbin Case Release Lever-----	1
26	916 L	Clamp Screw-----	1
27	1790 L	Hook Guard-----	1
28	LS314	Screw-----	1
29	1796 L	Pin, for Nos. 914 L, 1283 L-----	1
30	1186 L	Thread Controller Staff Barrel-----	1
31	1185 L	Washer-----	1
32	884 L	Thread Controller Spring-----	1
33	1799 L	Thread Controller Staff Stop-----	1
34	68-19	Thread Controller Staff-----	1
35	1189 L	Screw-----	1
36	20-60	Thread Tension Adjusting Nut-----	1
37	1132 L	Thread Tension Spring-----	1
38	1183 L	Thread Tension Disc-----	2
39	1725 L	Thread Tension Staff-----	1
40	1727 AL	Tension Disc Retainer, with pin-----	1
41	1081 L	Set Screw-----	1

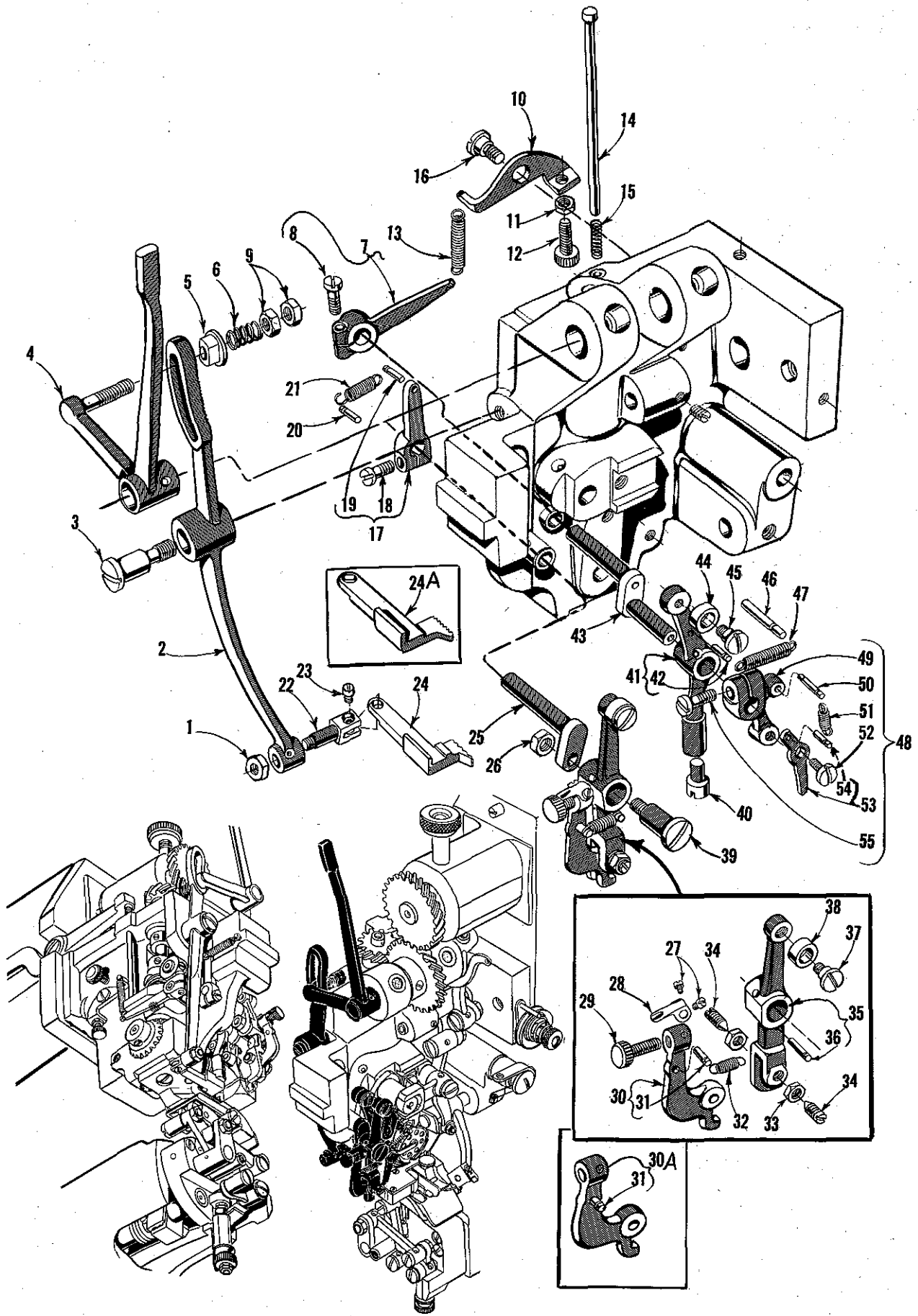

TOP FEED, TOP PLUNGER AND TOP FEED ROCKER LEVER PARTS

<u>Ref. No.</u>	<u>Part No.</u>	<u>Description</u>	<u>Amt. Req.</u>
1	CS231	Nut -----	1
2	1758 L	Top Feed Rocker Lever -----	1
3	CS307	Bearing Screw -----	1
4	45-421	Top Feed Adjusting Lever -----	1
5	1751 L	Top Feed Adjusting Slide Block -----	1
6	1752 L	Spring -----	1
7	1748 L	Top Feed Yielding Crank Lever -----	1
8	1750 L	Clamp Screw -----	1
9	1160 L	Nut -----	2
10	45-175	Lever, for spring adjustment -----	1
11	20-35	Nut -----	1
12	18-915	Screw -----	1
13	1283 L	Spring -----	1
14	1833 AL	Push Rod -----	1
15	1834 L	Spring -----	1
16	1220 L	Bearing Screw -----	1
17	1737 AL	Top Plunger Yielding Crank Lever -----	1
18	1750 L	Clamp Screw -----	1
19	1254 L	Spring Pin -----	1
20	1254 L	Spring Pin -----	1
21	1738 L	Spring, for Styles 30-210, 30-220, 30-410 -----	1
	1738 S	Spring, for Style 30-230 -----	1
22	1755 L	Top Feed Connecting Bearing -----	1
23	1757 L	Bearing Screw -----	1
24	23-135	Feed Point, upper, for Styles 30-210, 30-220, 30-410 -----	1
24A	23-186	Feed Point, upper, for Style 30-230 -----	1
25	48-8	Top Plunger Yielding Crank -----	1
26	1160 L	Nut -----	1
27	1036 L	Screw -----	2
28	1733 L	Retaining Spring -----	1
29	18-915	Adjusting Screw -----	1
30	445-31	Top Plunger Adjusting Lever, for Styles 30-210, 30-220, 30-410 -----	1
30A	445-95	Top Plunger Adjusting Lever, for Style 30-230 -----	1
31	1254 L	Spring Pin -----	1
32	1256 L	Retaining Spring -----	1
33	20-35	Nut -----	2
34	18-132	Pivot Screw -----	2
35	445-30	Top Plunger Rocker Lever -----	1
36	1254 L	Spring Pin -----	1
37	1731 L	Screw -----	1
38	1730 L	Roll -----	1
39	18-133	Bearing Screw -----	1
40	1744 L	Swivel Stud -----	1
41	1741 AL	Top Feed Cam Lever, complete -----	1
42	1254 L	Spring Pin -----	1
43	1746 L	Top Feed Yielding Crank -----	1
44	1730 L	Roll -----	1
45	1731 L	Screw -----	1
46	1055 L	Pin -----	1
47	1283 L	Spring -----	1
48	445-49	Lining Clamp Yielding Lever, complete -----	1
49	45-49	Lever, upper -----	1
50	22-43	Pin -----	1
51	21-58	Spring -----	1
52	18-180	Screw -----	1
53	445-50	Lever, lower -----	1
54	1254 L	Pin -----	1
55	1750 L	Clamp Screw -----	1

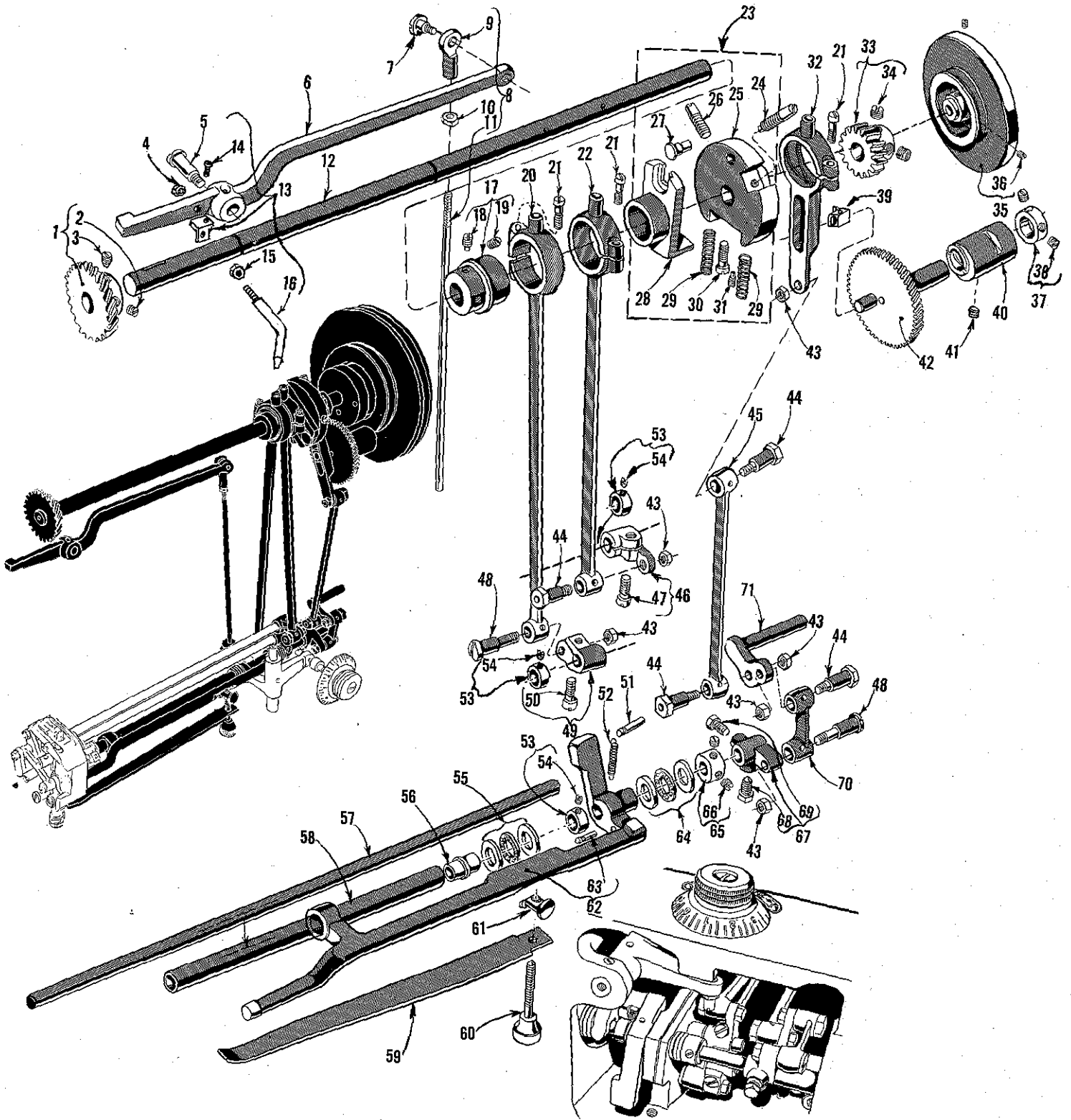

MAIN SHAFT, FEED AND PLUNGER DRIVING PARTS

<u>Ref. No.</u>	<u>Part No.</u>	<u>Description</u>	<u>Amt. Req.</u>
1	1804 L	Head Driving Gear -----	1
2	1005 L	Set Screw-----	1
3	1203 L	Spot Screw -----	1
4	20-35	Nut, for thread tension release -----	1
5	CS307	Bearing Screw -----	1
6	45-433	Top Feed Depressing Lever -----	1
7	1830 L	Screw -----	1
8	471-100	Connecting Rod, complete-----	1
9	1826 L	Connecting Rod Adjuster -----	1
10	CS231	Nut -----	1
11	71-100	Rod -----	1
12	14-325	Main Shaft-----	1
13	445-473	Thread Tension Release Assembly -----	1
14	18-602	Screw, for tension release -----	1
15	20-35	Nut, for tension release rod -----	1
16	51-291 Blk.	Thread Tension Release Rod-----	1
17	1204 L	Feed Elevating Eccentric -----	1
18	1147 L	Spot Screw -----	1
19	1005 L	Set Screw -----	1
20	47-115	Feed Elevating Connecting Rod -----	1
21	1206 L	Clamp Screw -----	3
22	1205 L	Feed Driving Connecting Rod -----	1
23	433-132	Feed Driving and Plunger Crank Eccentric, complete -----	1
24	1210 L	Spot Screw-----	1
25	33-132	Eccentric-----	1
26	1211 L	Set Screw-----	1
27	1208 L	Guide Pin-----	1
28	1212 L	Feed Adjusting Eccentric-----	1
29	1214 L	Spring -----	2
30	1213 L	Screw -----	1
31	1020 L	Spot Screw-----	1
32	47-7	Plunger Connecting Rod, upper -----	1
33	1805 L	Plunger Pinion -----	1
34	1005 L	Set Screw -----	2
35	57-42	Handwheel -----	1
36	CS320-1/2	Set Screw -----	2
37	39-92	Collar -----	1
38	1025 L	Set Screw-----	2
39	1149 L	Slide Block -----	1
40	16-277	Eccentric Plunger Gear Bushing -----	1
41	CS320-1/2	Set Screw -----	1
42	427-17	Gear, for plunger, complete -----	1
43	1009 L	Nut -----	6
44	1288 L	Bearing Screw -----	4
45	1818 L	Plunger Connecting Rod, lower -----	1
46	1839 AL	Feed Driving Crank -----	1
47	1243 L	Clamp Screw -----	1
48	1244 L	Bearing Screw -----	2
49	448-75	Feed Elevating Crank -----	1
50	1243 L	Clamp Screw-----	1
51	1055 L	Pin -----	1
52	1283 L	Spring -----	1
53	1284 L	Collar -----	3
54	1022 L	Set Screw-----	1
55	478-23	Ball Bearing, complete with washers -----	1
56	16-366	Plunger Rocker Shaft Bushing -----	1
57	1295 L	Plunger Rocker Shaft -----	1
58	61-82	Plunger Rocker Shaft Tube -----	1
59	1270 L	Flat Feed Spring -----	1
60	1271 L	Adjusting Screw, for spring -----	1
61	1272 L	Nut -----	1
62	449-32	Feed Depresser Yoke, complete with pin, for use without 16-379 bushing -----	1
	449-33	Feed Depresser Yoke, for new machines with 16-379 bushing -----	1
63	1281 L	Spring Pin -----	1
64	478-11	Ball Bearing, complete with washers, for use without 16-379 bushing -----	1
	1027 L	Collar -----	1
66	1029 L	Set Screw -----	2
67	1293 L	Plunger Rocker Crank -----	1
68	1294 L	Spot Screw -----	1
69	1333 L	Set Screw -----	1
70	1292 L	Plunger Differential Crank Link-----	1
71	1291 L	Plunger Differential Crank -----	1

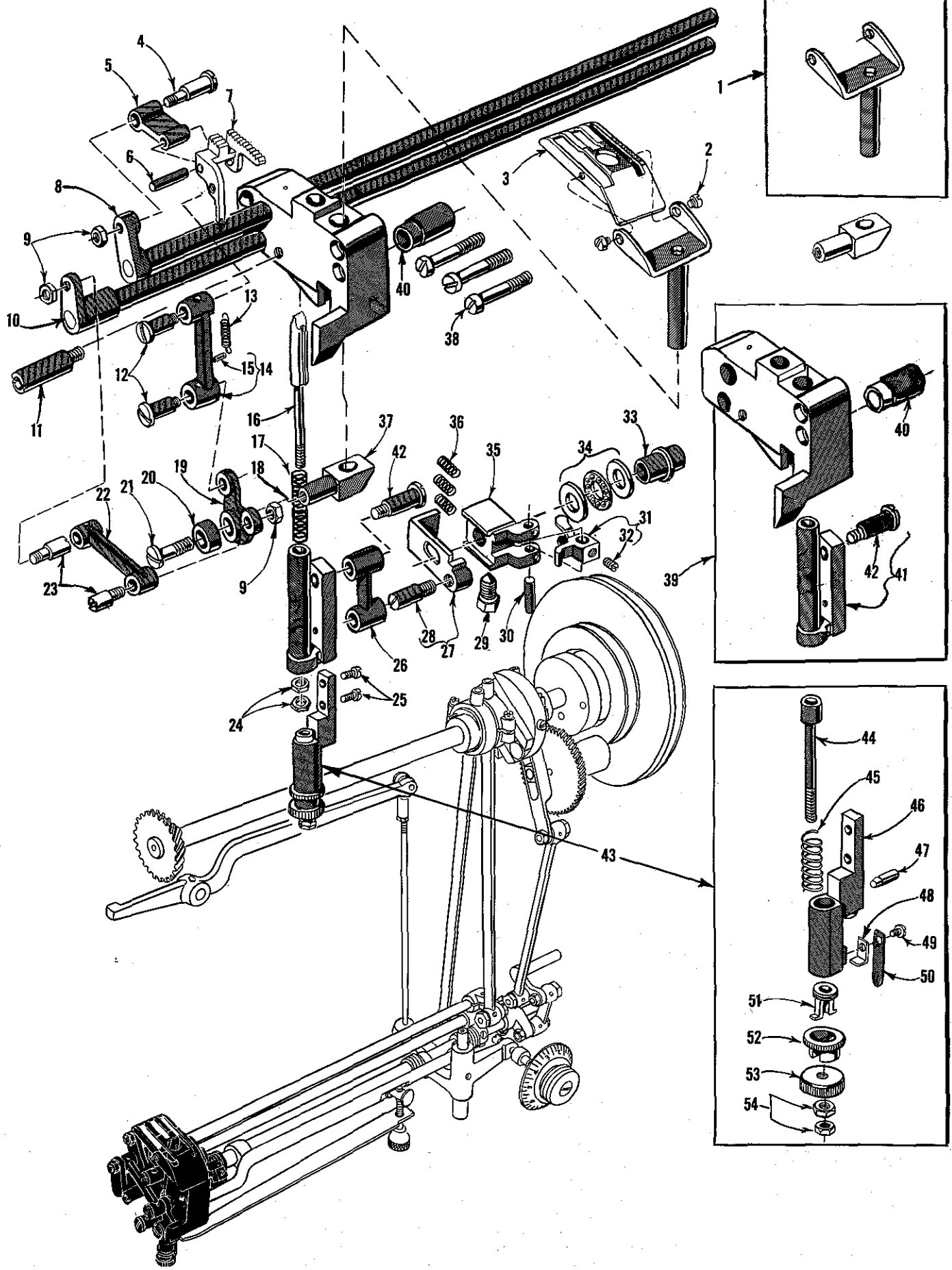

AUTOMATIC PLUNGER, FEED DRIVING AND PLUNGER DRIVING PARTS

Ref. No.	Part No.	Description	Amt. Req.
1	49-36	Feed Plate Yoke and Stem, complete-----	1
2	1414 L	Screw, for feed plate-----	2
3		Feed Plate (See Page No. 29) -----	1
4	1260 L	Bearing Screw, for feed point-----	1
5	1261 L	Feed Link-----	1
6	1262 L	Hinge Pin-----	1
7		Feed Point (See Page No. 29) -----	1
8	LS135 A	Feed Rocker Shaft, complete -----	1
9	1160 L	Nut -----	3
10	1248 AL	Feed Elevating Rocker Shaft, with crank -----	1
11	1667 L	Stud, for No. 115-72 -----	1
12	1671 L	Bearing Screw -----	2
13	1256 L	Feed Retaining Spring-----	1
14	1677 AL	Feed Elevating Link, complete -----	1
15	1254 L	Spring Pin -----	1
16		Plunger (See Page No. 29) -----	1
17	1310 L	Plunger Spring, light, for Styles 30-210, 30-220, 30-410 -----	1
	1584 L	Plunger Spring, medium, for Style 30-230 -----	1
18	18-533	Set Screw, for slide block -----	1
19	1669 L	Feed Elevating Bell Crank-----	1
20	1672 L	Roll, for slide block, .500 inch diameter-----	1
	1672 L-1	Roll, for slide block, .505 inch diameter-----	1
	1672 L-2	Roll, for slide block, .510 inch diameter-----	1
	1672 L-3	Roll, for slide block, .515 inch diameter-----	1
21	18-745	Bearing Screw -----	1
22	46-94	Feed Elevating Link-----	1
23	1249 L	Bearing Stud -----	2
24	1311 L	Nut, for plunger -----	2
25	18-791	Screw, for automatic plunger -----	2
26	1304 L	Plunger Frame Link -----	1
27	48-168	Plunger Crank -----	1
28	18-1027	Bearing Screw -----	1
29	1298 L	Spot Screw, for No. 115-139-----	1
30	22-297	Pin -----	1
31	48-165	Plunger Regulating Bell Crank, small-----	1
32	18-416	Set Screw -----	1
33	16-366	Plunger Rocker Shaft Bushing -----	1
34	478-23	Ball Bearing, complete with washers -----	1
35	115-139	Plunger Regulating Block -----	1
36	21-403	Plunger Crank Spring -----	3
37	1273 L	Slide Block -----	1
38	1279 L	Clamp Screw, for No. 4115-72-4 -----	3
39	4115-72-4	Feed and Plunger Bearing Block, complete -----	1
40	16-352	Bushing -----	1
41	4121-3	Plunger Frame and Barrel Assembly-----	1
42	1306 L	Screw -----	1
43	426-93	Automatic Plunger, complete, for Style 30-210, 30-410 -----	1
	426-93-1	Automatic Plunger, complete, for Styles 30-220, 30-230-----	1
44	26-93	Plunger -----	1
45	21-230	Spring, for No. 426-93 -----	1
	21-281	Spring, for No. 426-93-1-----	1
46	50-138	Bracket -----	1
47	22-9	Pin -----	1
48	42-14	Stop -----	1
49	18-125	Screw-----	1
50	21-19	Retaining Spring -----	1
51	70-33	Sleeve -----	1
52	149-22	Regulator -----	1
53	20-98	Nut -----	1
54	1311 L	Nut -----	1

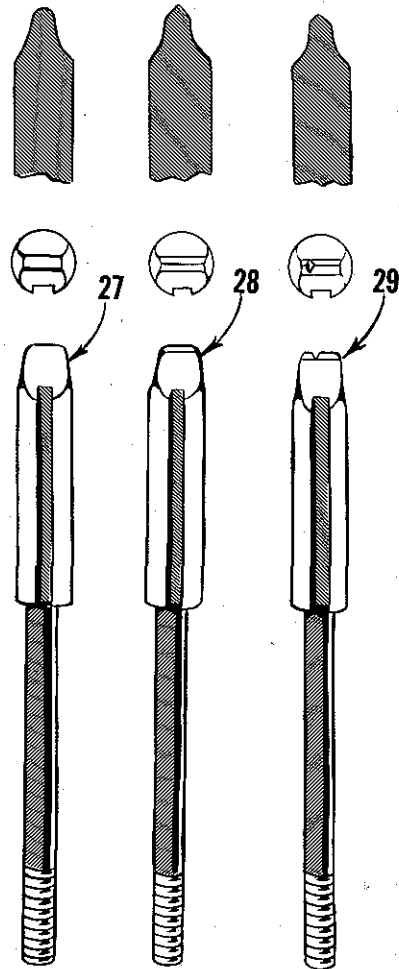
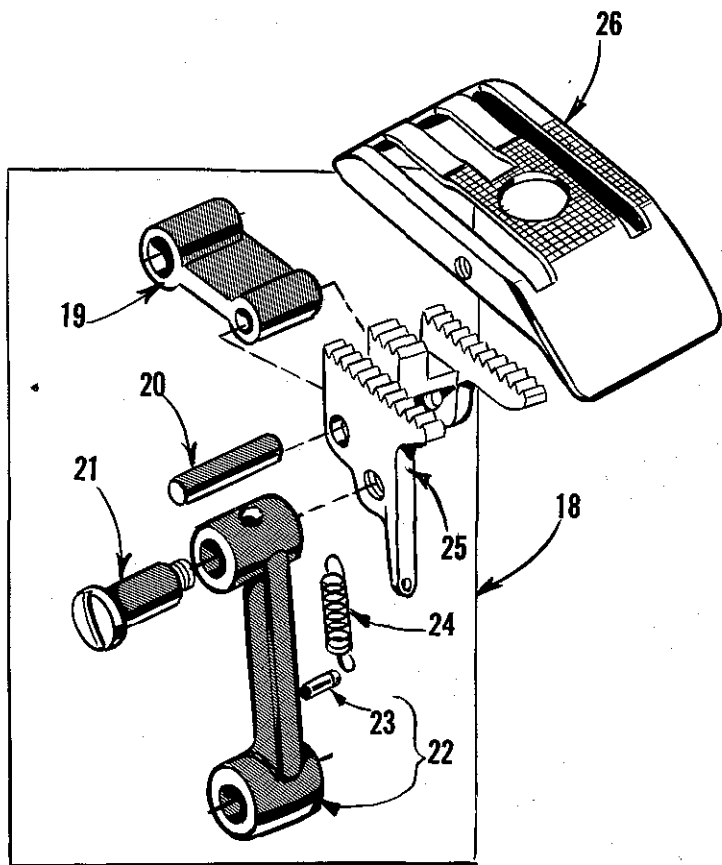
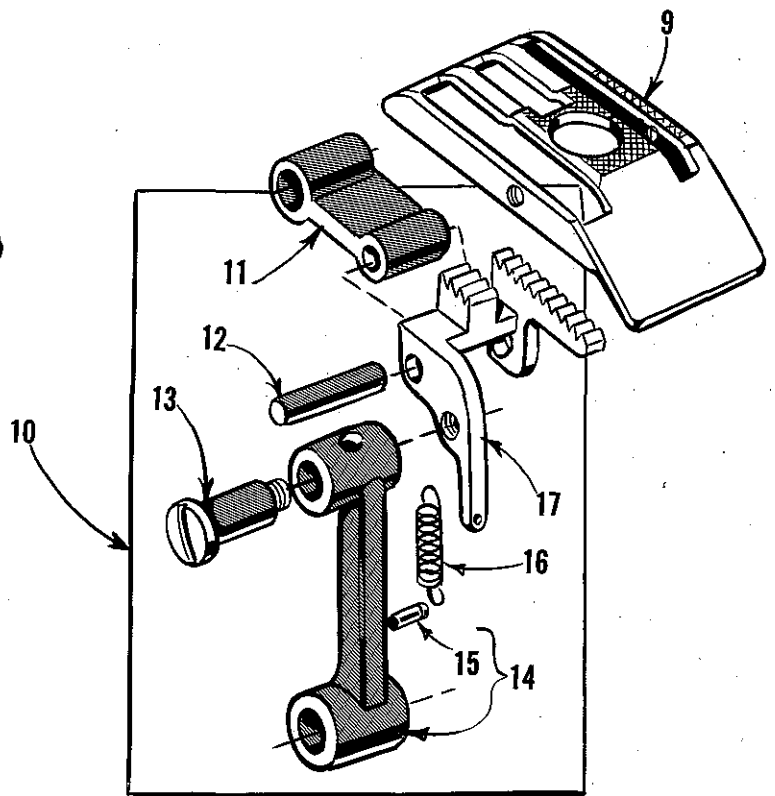
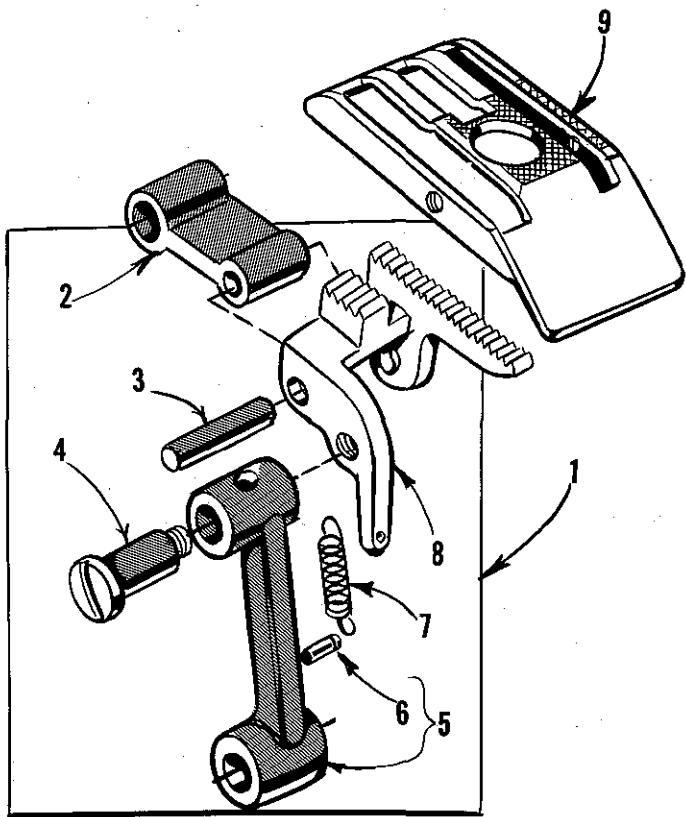

FEED POINTS, FEED PLATES AND PLUNGERS

<u>Ref. No.</u>	<u>Part No.</u>	<u>Description</u>	<u>Amt. Req.</u>
1	423-323	Feed Point, complete, for Styles 30-210, 30-410 ----	1
2	1261 L	Feed Link -----	1
3	1262 L	Hinge Pin-----	1
4	1671 L	Bearing Screw -----	1
5	1677 AL	Feed Elevating Link, complete-----	1
6	1254 L	Spring Pin -----	1
7	1256 L	Feed Retaining Spring-----	1
8	23-323	Feed Point, 16 teeth per inch-----	1
9	24-287	Feed Plate, for Styles 30-210, 30-220, 30-410 ----	1
10	423-325	Feed Point, complete, for Style 30-220 -----	1
11	1261 L	Feed Link -----	1
12	1262 L	Hinge Pin-----	1
13	1671 L	Bearing Screw -----	1
14	1677 AL	Feed Elevating Link, complete-----	1
15	1254 L	Spring Pin -----	1
16	1256 L	Feed Retaining Spring-----	1
17	23-325	Feed Point, approximately 10 teeth per inch----	1
18	423-324	Feed Point, complete, for Style 30-230 -----	1
19	1261 L	Feed Link -----	1
20	1262 L	Hinge Pin-----	1
21	1671 L	Bearing Screw -----	1
22	1677 AL	Feed Elevating Link, complete-----	1
23	1254 L	Spring Pin -----	1
24	1256 L	Feed Retaining Spring-----	1
25	23-324	Feed Point, approximately 10 teeth per inch----	1
26	24-293	Feed Plate, for Style 30-230-----	1
27	1825 L	Plunger, for Styles 30-220, 30-230-----	1
28	26-154	Plunger, for Styles 30-210, 30-410-----	1
29	26-180	Plunger, for tropical materials -----	1

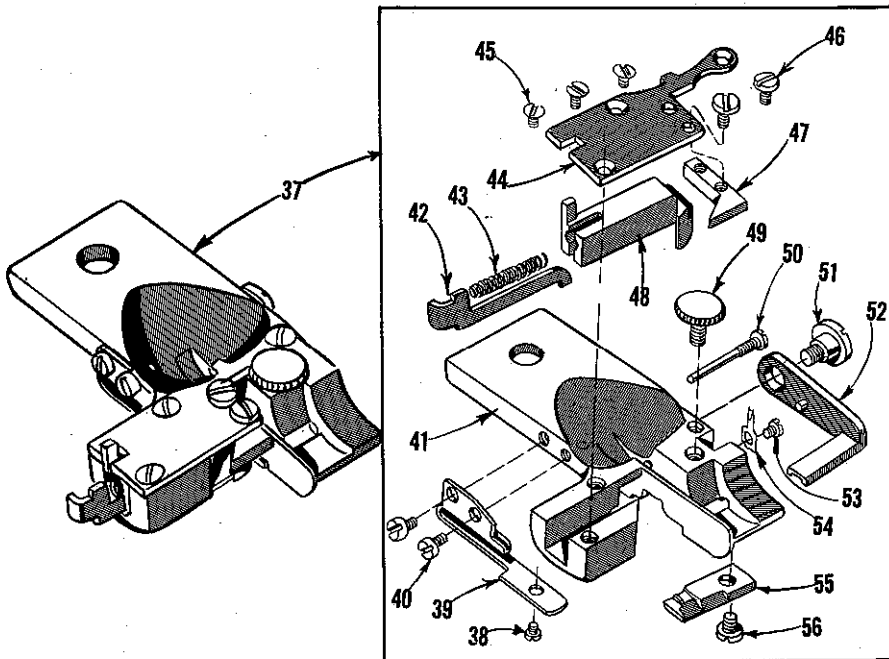
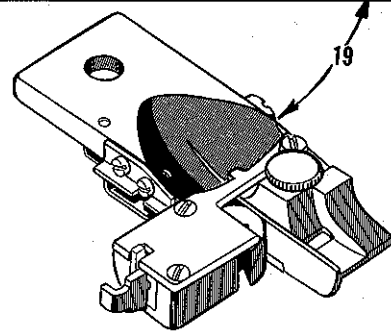
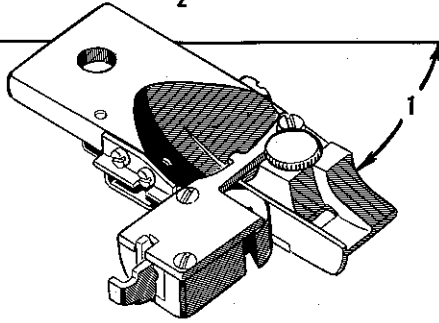
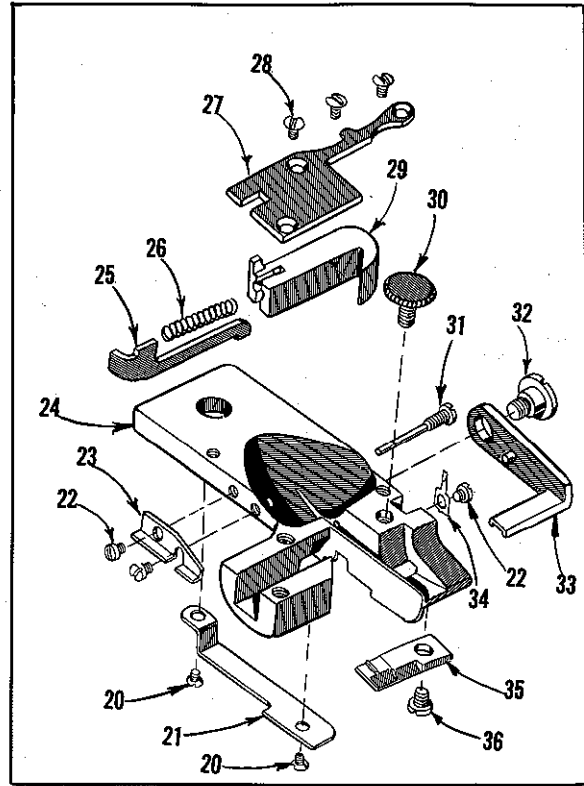
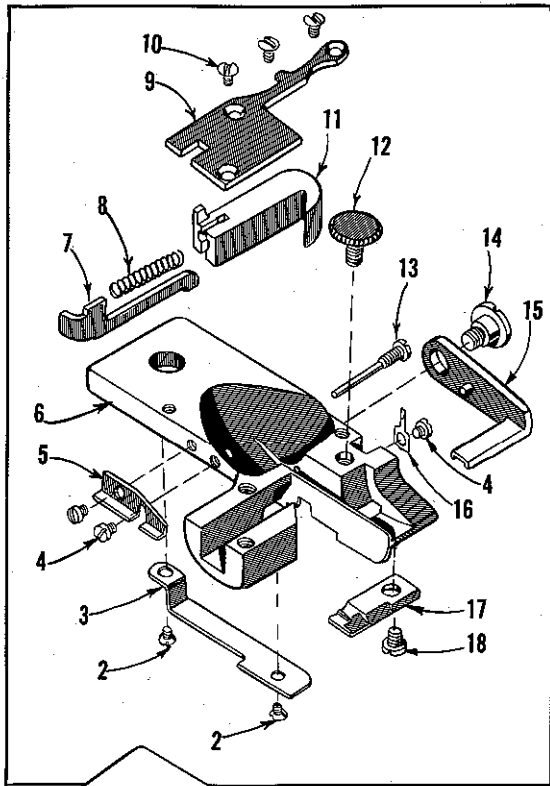

PRESSER FEET

<u>Ref. No.</u>	<u>Part No.</u>	<u>Description</u>	<u>Amt. Req.</u>
1	405-494	Presser Foot, complete, for Style 30-210-----	1
	405-494-1	Presser Foot, complete, for Style 30-410-----	1
2	1789 L	Screw-----	2
3	75-209	Guide, lower-----	1
4	1036 L	Screw-----	3
5	75-81	Guide, upper-----	1
6	5-494	Presser Foot Bottom-----	1
7	26-10	Plunger, upper-----	1
8	1784 L	Spring-----	1
9	12-4	Bobbin Case Retainer-----	1
10	18-134	Screw-----	3
11	30-28	Lining Clamp-----	1
12	1777 L	Crown Adjusting Screw-----	1
13	1787 L	Foot Bridge Screw-----	1
14	1776 L	Crown Retaining Screw-----	1
15	4126-48	Crown, for Style 30-210-----	1
	4126-19	Crown, for Style 30-410-----	1
16	1778 L	Retaining Spring-----	1
17	6-18	Needle Guide-----	1
18	18-607	Screw-----	1
19	405-495	Presser Foot, complete, for Style 30-220-----	1
*	405-496	Presser Foot, complete, for heavy weight material, for Style 30-220-----	1
20	1789 L	Screw-----	2
21	75-209	Guide, lower-----	1
22	1036 L	Screw-----	3
23	75-81	Guide, upper-----	1
24	5-495	Presser Foot Bottom, for presser foot No. 405-495-----	1
-	5-496	Presser Foot Bottom, for presser foot No. 405-496-----	1
25	26-10	Plunger, upper-----	1
26	1784 L	Spring-----	1
27	12-4	Bobbin Case Retainer-----	1
28	18-134	Screw-----	3
29	30-28	Lining Clamp-----	1
30	1777 L	Crown Adjusting Screw-----	1
31	1787 L	Foot Bridge Screw-----	1
32	1776 L	Crown Retaining Screw-----	1
33	4126-48	Crown-----	1
34	1778 L	Retaining Spring-----	1
35	6-19	Needle Guide, for presser foot No. 405-495-----	1
-	6-20	Needle Guide, for presser foot No. 405-496-----	1
36	18-607	Screw-----	1
37	405-535	Presser Foot, complete, for Style 30-230-----	1
38	1789 L	Screw-----	1
39	50-23	Bracket-----	1
40	1075 L	Screw-----	2
41	5-535	Presser Foot Bottom-----	1
42	26-15	Plunger-----	1
43	21-363	Spring-----	1
44	12-20	Bobbin Case Retainer-----	1
45	18-134	Screw-----	3
46	18-340	Screw-----	2
47	75-227	Edge Guide-----	1
48	30-67	Lining Clamp-----	1
49	1777 L	Crown Adjusting Screw-----	1
50	1787 L	Foot Bridge Screw-----	1
51	1776 L	Crown Retaining Screw-----	1
52	4126-48	Crown-----	1
53	1036 L	Screw-----	1
54	1778 L	Retaining Spring-----	1
55	6-19	Needle Guide-----	1
56	18-607	Screw-----	1

* Alternate presser foot for sewing heavy weight material on Style 30-220.

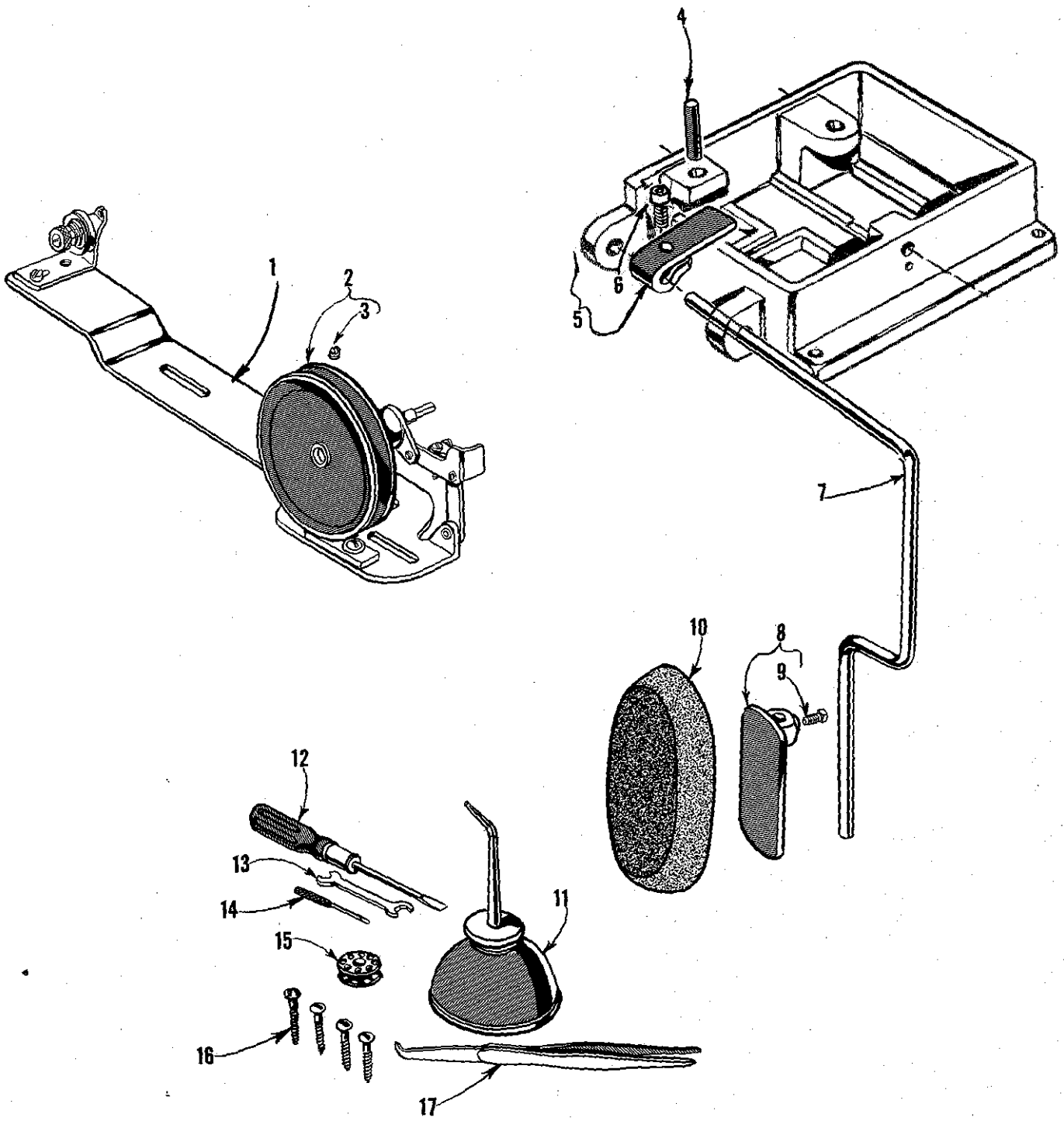

ACCESSORIES

<u>Ref. No.</u>	<u>Part No.</u>	<u>Description</u>	<u>Amt. Req.</u>
1	61477 M	Bobbin Winder, complete -----	1
2	61377 Y	Pulley -----	1
3	22878	Set Screw -----	1
4	22-301	Feed Plate Lowering Pin-----	1
5	45-422	Knee Press Lever -----	1
6	22652 F-12	Clamp Screw -----	1
7	71-86	Knee Press Rod -----	1
8	4129-18	Knee Press Plate, complete-----	1
9	22508	Screw-----	1
*10	660-168	Knee Press Plate Cushion, sponge rubber -----	1
11	413	Oil Can -----	1
12	21201	Screwdriver, 9/64 inch round blade, overall length 7 11/16 inches-----	1
13	1405 L	Double End Wrench, 1/4 inch and 5/16 inch open- ing -----	1
14	21207 B	Screwdriver, 7/64 inch round blade, overall length 2 1/2 inches -----	1
15	1047 L	Bobbin -----	1
16	1500 L	Wood Screw -----	4
17	660-240	Thread Tweezers -----	1
-	660-457	Dust Cover (not shown on picture plate)-----	1

* Not furnished with machine, order as extra send and charge item.

NUMERICAL INDEX OF PARTS

Part No.	Page No.	Part No.	Page No.	Part No.	Page No.
3-91.....	17	20-98.....	27	51-291 Blk	25
4-136.....	17	20-134.....	17	57-42.....	25
5-494.....	31	21-19.....	27	61-75.....	17
5-495.....	31	21-58.....	23	61-79.....	17
5-496.....	31	21-230.....	27	61-82.....	25
5-535.....	31	21-237.....	17	68-19.....	21
6-18.....	31	21-281.....	27	69-18.....	21
6-19.....	31	21-363.....	31	70-33.....	27
6-20.....	31	21-403.....	27	71-86.....	33
12-4.....	31	21-404.....	17	71-100.....	25
12-20.....	31	22-9.....	27	75-81.....	31
14-325.....	25	22-43.....	23	75-209.....	31
14-426.....	19	22-148.....	17	75-227.....	31
14-472.....	17	22-C214-2.....	17	79-31.....	17
14-508.....	17	22-C214-4.....	17	110-358.....	17
15-21.....	21	22-296.....	17	115-139.....	27
16-277.....	25	22-297.....	27	118-31.....	19
16-352.....	27	22-301.....	33	125-23.....	17, 21
16-354.....	17	23-135.....	23	LS135 A.....	27
16-356.....	17	23-186.....	23	147-10.....	17
16-366.....	25, 27	23-323.....	29	147-22.....	19
16-368.....	17	23-324.....	29	149-22.....	27
16-379.....	17	23-325.....	29	CS231.....	23, 25
16-382.....	19	24-287.....	29	LS299.....	17
16-383.....	21	24-293.....	29	CS307.....	23, 25
17-137.....	21	26-10.....	31	CS313.....	17
17-167.....	17	26-15.....	31	LS314.....	19, 21
17-175.....	19	26-93.....	27	CS320-1/2.....	17, 25
18-125.....	27	26-154.....	29	LS330.....	19
18-132.....	23	26-180.....	29	LS398.....	17
18-133.....	23	30-28.....	31	405-494.....	31
18-134.....	31	30-67.....	31	405-494-1.....	31
18-180.....	23	32-276.....	17	405-495.....	31
18-227.....	19	33-132.....	25	405-496.....	31
18-340.....	31	34-9.....	21	405-535.....	31
18-416.....	27	34-28.....	21	413.....	33
18-533.....	27	39-92.....	25	416-10.....	19
18-596.....	17	39-128.....	17	416-367.....	17
18-602.....	25	40-139.....	17	418-1026.....	17
18-607.....	31	41-55.....	17	423-323.....	29
18-745.....	27	42-14.....	27	423-324.....	29
18-791.....	27	44-301.....	17	423-325.....	29
18-844.....	21	45-50.....	23	426-325.....	29
18-902.....	19	45-175.....	23	426-93.....	27
18-903.....	17	45-421.....	23	426-93-1.....	27
18-912.....	19	45-422.....	33	427-17.....	25
18-915.....	23	45-433.....	25	432-278.....	17
18-957.....	17	46-94.....	27	432-280.....	17
18-959.....	17	46-146.....	21	433-132.....	25
18-998.....	17	47-7.....	25	445-30.....	23
18-1027.....	27	47-115.....	25	445-31.....	23
18-1028.....	17	48-8.....	23	445-49.....	23
18-1030.....	17	48-165.....	27	445-50.....	32
18-1037.....	17	48-166.....	17	445-95.....	23
18-1045.....	17	48-168.....	27	445-235.....	19
18-1046.....	17	49-36.....	27	445-473.....	25
18-1094.....	21	50-23.....	31	448-75.....	25
20-34.....	17	50-138.....	27	449-33.....	25
20-35.....	23, 25	50-262.....	17	471-100.....	25
20-60.....	21	50-263 L.....	17	478-11.....	25
		51-26.....	17	478-23.....	25, 27

NUMERICAL INDEX OF PARTS

<u>Part No.</u>	<u>Page No.</u>	<u>Part No.</u>	<u>Page No.</u>	<u>Part No.</u>	<u>Page No.</u>
FP505.....	17	1214 L.....	25	1733 L.....	23
531.....	33	1220 L.....	23	1735 L.....	21
660-168.....	33	1243 L.....	25	1737 AL.....	23
660-240.....	33	1244 L.....	25	1738 L.....	23
660-457.....	33	1248 AL.....	27	1738 S.....	23
666-65.....	17	1249 L.....	27	1739 SL.....	21
666-163.....	17	1254 L.....	23,27,29	1741 AL.....	23
782 L.....	21	1256 L.....	23,27,29	1744 L.....	23
876 L.....	19	1260 L.....	27	1746 L.....	23
884 L.....	21	1261 L.....	27,29	1748 L.....	23
887 L.....	19	1262 L.....	27,29	1750 L.....	23
888 L.....	19	1270 L.....	25	1751 L.....	23
905 AL.....	19	1271 L.....	25	1752 L.....	23
906 A-1 L.....	19	1272 L.....	25	1755 L.....	23
914 L.....	21	1273 L.....	27	1757 L.....	23
915 L.....	21	1279 L.....	27	1758 L.....	23
916 L.....	21	1281 L.....	25	1761 L.....	19
1003 L.....	19	1283 L.....	23,25	1762 L.....	19
1005 L.....	17,21,25	1284 L.....	25	1763 L.....	21
1009 L.....	25	1288 L.....	25	1764 L.....	19
1019 L.....	19	1291 L.....	25	1776 L.....	31
1020 L.....	25	1292 L.....	25	1777 L.....	31
1022 L.....	19,21,25	1293 L.....	25	1778 L.....	31
1025 L.....	19,21,25	1294 L.....	25	1784 L.....	31
1027 L.....	19,25	1295 L.....	25	1787 L.....	31
1028 L.....	19	1298 L.....	27	1789 L.....	31
1029 L.....	19,25	1304 L.....	25	1790 L.....	21
1030 L.....	19	1306 L.....	27	1791 L.....	19
1031 L.....	19	1310 L.....	27	1791 AL.....	19
1035 L.....	19	1311 L.....	21,27	1794 AL.....	21
1036 L.....	19,23,31	1321 L.....	17	1795 L.....	21
1037 L.....	19	1333 L.....	25	1796 L.....	21
1039 L.....	19	1405 L.....	33	1797 L.....	19
1041 AL.....	19	1414 L.....	27	1799 L.....	21
1043 L.....	19	1500 L.....	33	1804 L.....	25
1046 L.....	19	1584 L.....	27	1805 L.....	25
1047 L.....	19,33	1667 L.....	27	1818 L.....	25
1055 L.....	17,23,25	1669 L.....	27	1825 L.....	29
1075 L.....	19,31	1671 L.....	27,29	1826 L.....	25
1081 L.....	17,21	1672 L.....	27	1830 L.....	25
1132 L.....	21	1672 L-1.....	27	1833 AL.....	23
1137 L.....	17	1672 L-2.....	27	1834 L.....	23
1147 L.....	25	1672 L-3.....	27	1839 AL.....	25
1149 L.....	25	1677 AL.....	27,29	4115-72-4.....	27
1160 L.....	17,19,21, 23,27	1702 L.....	21	4121-3.....	27
1173 L.....	17	1703 L.....	21	4126-19.....	31
1183 L.....	21	1705 AL-1/2.....	19	4126-48.....	31
1185 L.....	21	1706 L.....	19	4129-18.....	33
1186 L.....	21	1707 L.....	19	4149-30.....	17
1189 L.....	21	1708 L.....	19	21201.....	33
1192 L.....	17	1709 L.....	19	21207 B.....	33
1203 L.....	25	1710 L.....	19	22508.....	33
1204 L.....	25	1711 L.....	19	22564 D.....	17
1205 L.....	25	1712 L.....	19	22652 F-12.....	33
1206 L.....	25	1717 L.....	21	22878.....	33
1208 L.....	25	1718 L.....	21	61248 H.....	33
1210 L.....	25	1719 L.....	21	61377 Y.....	33
1211 L.....	25	1725 L.....	21	61477 M.....	33
1212 L.....	25	1727 AL.....	21	63470 A.....	17
1213 L.....	25	1730 L.....	23		
		1731 L.....	23		

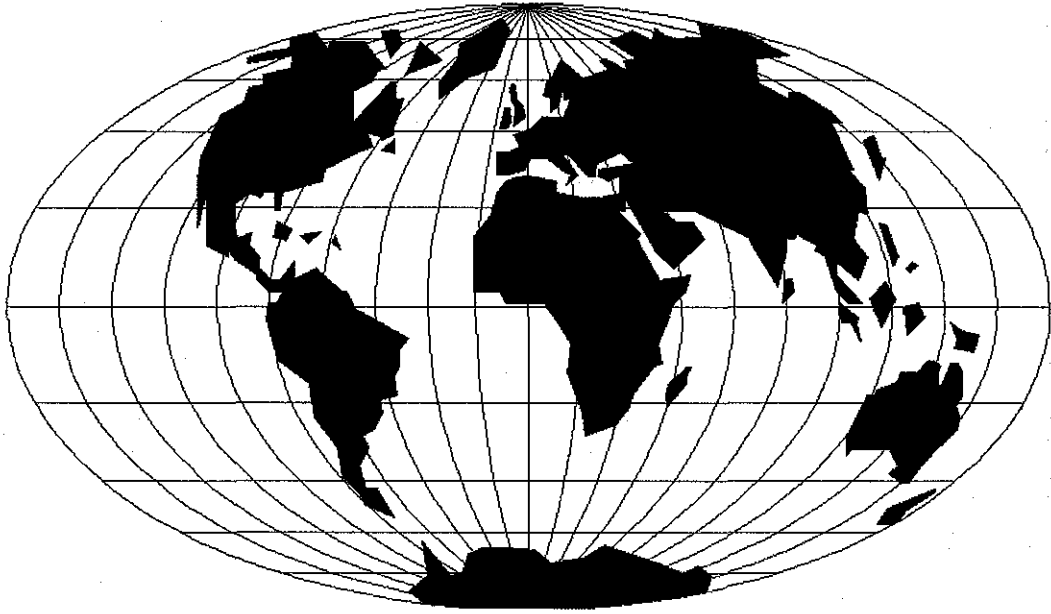

WORLDWIDE SALES AND SERVICE

Union Special Corporation maintains sales and service facilities throughout the world. These offices will aid you in the selection of the right sewing equipment for your particular operation. Union Special Corporation representatives and service technicians are factory trained and are able to serve your needs promptly and efficiently. Whatever your location, there is a qualified representative to serve you.

Corporate
Office: One Union Special Plaza
Huntley, IL 60142
Phone: 847•669•5101
Fax: 847•669•4454

European Distribution Center: Union Special GmbH
Raiffeisenstrasse 3
D-71696 Möglingen, Germany
Tel: 49•07141•247•0
Fax: 49•7141•247•100

Brussels, Belgium
Charlotte, N.C.
El Paso, TX
Hong Kong, China
Huntley, IL
Leicester, England
Lille, France
Miami, FL
Milan, Italy
Möglingen, Germany
Montreal, Quebec
Osaka, Japan
Santa Fe Springs, CA

Other Representatives throughout
all parts of the world.



Union Special
INDUSTRIAL SEWING EQUIPMENT