

PART NUMBER
29476YE
 FOR 29480AZP

ADD WASHER(S) 35886M AS NECESSARY
 TO POSITION AIR CYLINDER PROPERLY
 TO AVOID AIR LINE FITTING INTERFERENCE

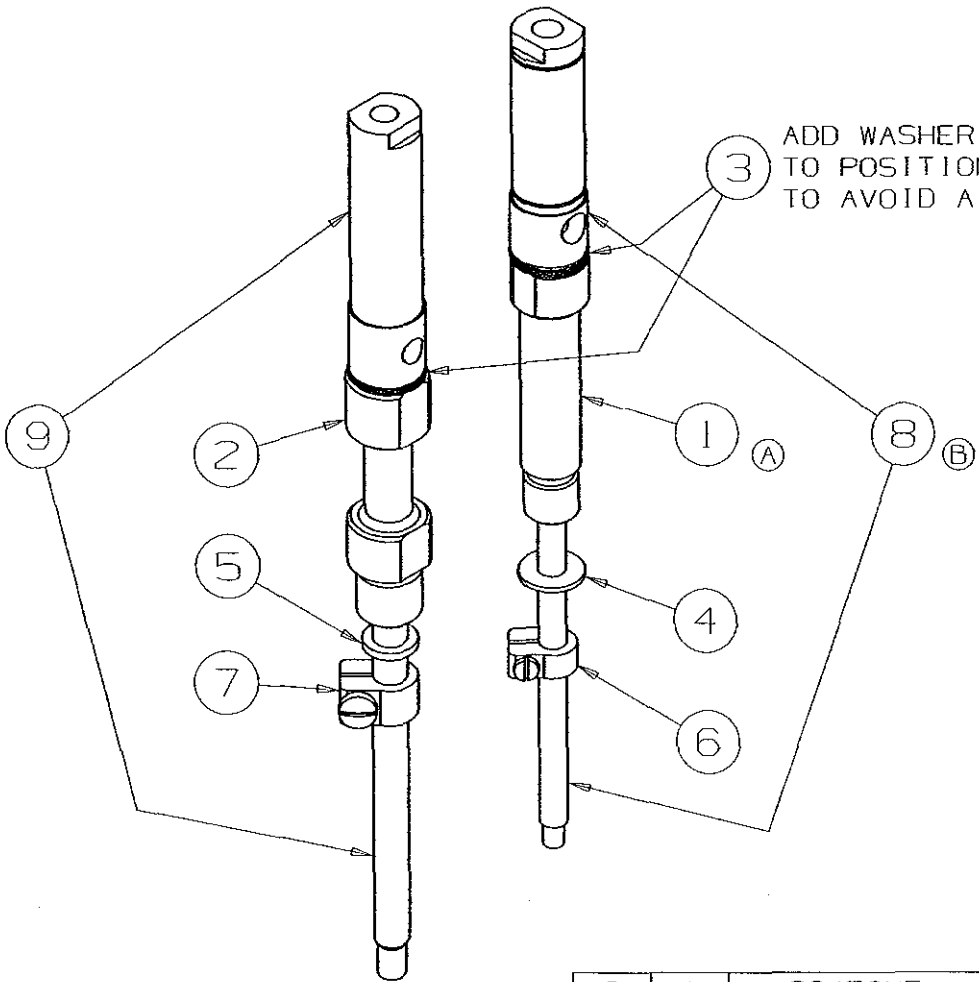

9	1	29476YF	PULLER BAR ASSY.
8	1	29476ZN	PRESSER BAR ASSY.
7	1	35833R	CLAMP COLLAR
6	1	35833S	CLAMP COLLAR
5	1	35886H	WASHER
4	1	35886J	WASHER
3	6	35886M	WASHER
2	1	671A272	PULLER BAR ADAPTER
1	1	671A272A	ADAPTER, PRESSER BAR
DET	AMT	PART NUMBER	DESCRIPTION

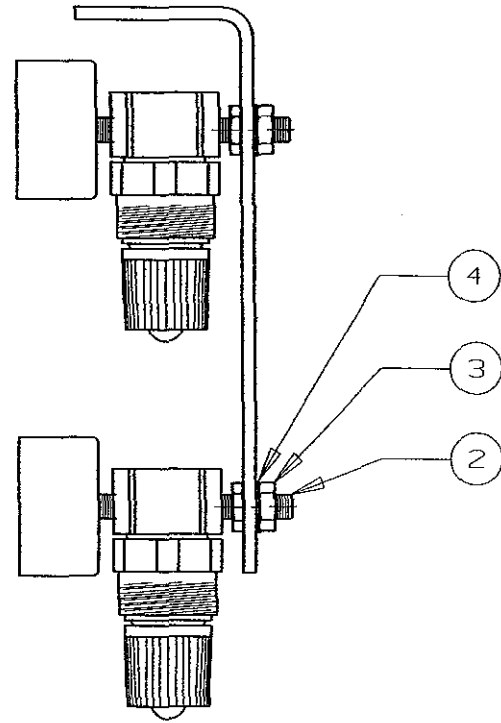
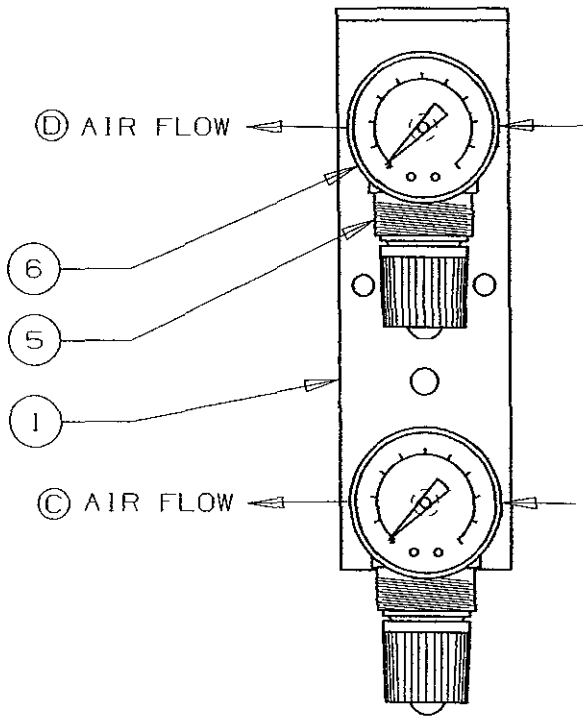

6	2	GR-671D10	GAUGE
5	2	671D9	REGULATOR
4	2	652B20	WASHER
3	2	11635B	NUT
2	2	671C16	MOUNTING STUD
1	1	99683CC	MOUNT BRACKET
DET	AMT	PART NUMBER	DESCRIPTION

MATERIAL

Union Special

PL1447

Air line connections for treadle rod switch & air cylinders for roller & presser foot

Second Edition Copyright February 1996 by Union Special Corporation Rights Reserved In All Countries Printed In U.S.A.

