

D Wickell

~~194-8~~  
194-8

**LEWIS**

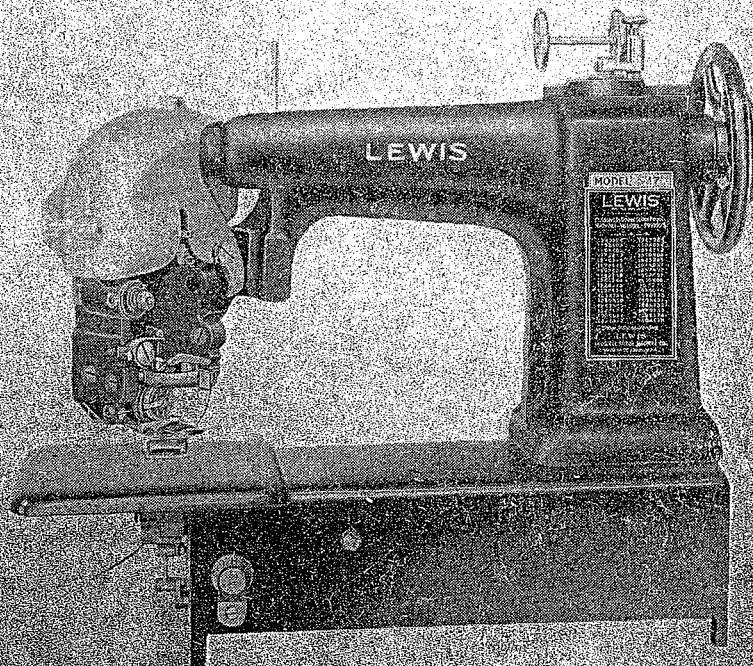

**PARTS and INSTRUCTIONS**  
FOR  
**17 & 24 CLASS MACHINES**

Models

17-10

24-12

**LEWIS INVISIBLE STITCH MACHINE COMPANY**

FACTORY  
ST. LOUIS MO., U. S. A.

MAIN OFFICE  
129-131 West 22nd Street  
NEW YORK 11, N. Y., U. S. A.



INDEX

	Page
Adjusting Instructions . . . . .	5 to 27
Automatic Tension Release. . . . .	24
Basting Work, Model 24-12. . . . .	22
Bight, how to adjust width. . . . .	12
Bobbin, how to insert. . . . .	9
Bobbin Case, how to replace. . . . .	13, 14
Bobbin Case Release. . . . .	16
Breaking Thread, how to overcome . . . . .	25, 26
Catalogue, how to use . . . . .	5
Feed Plate Pressure, how to adjust . . . . .	13
Feed Point, raising and lowering. . . . .	21
Foreign Shipments, how to mount head, and clean hook and parts of oil . . . . .	6
Groups, Key to. . . . .	3, 4
Groups, list of . . . . .	2
Hand Wheel . . . . .	6
Hook, how to replace and time. . . . .	14, 15
Hook, raising and lowering. . . . .	15, 16
Inserting and Removing Work . . . . .	9, 10
Instructions for Adjusting. . . . .	5 to 27
Instructions for Ordering Parts. . . . .	5
Models, General Description . . . . .	5, 6
Model 24-12, Operating . . . . .	21 to 23
Model 17-10, Operating . . . . .	19
Needles. . . . .	7, 8
Numerical List of Parts. . . . .	72 to 75
Oiling and Cleaning. . . . .	6, 7
Ordering Parts. . . . .	5, 6
Parts, Numerical List. . . . .	72 to 75
Penetration, how to adjust . . . . .	22
Plunger Barrel, how to remove. . . . .	18
Plunger, how to raise and lower . . . . .	19, 20
Plunger, how to remove. . . . .	17, 18
Presser Foot, removing and replacing . . . . .	13
Sack Coats and Overcoats. . . . .	20, 21, 23
Setting Up of Machine . . . . .	6
Skipping Stitches, how to overcome . . . . .	26
Speed of Machine . . . . .	7
Stitch Length, how to adjust . . . . .	10
Straight Felling Stitch, how to produce . . . . .	19
Tensions, how to adjust . . . . .	12
Thread To Use. . . . .	8, 9
Thread Breakage, how to overcome . . . . .	25, 26

## INDEX

	Page
Thread Controller Spring . . . . .	16
Threading . . . . .	9
Timing Needle with Plunger . . . . .	17
Two to One Stitch. . . . .	19, 20
Unpacking Machine. . . . .	6
Width of Bight, how to adjust . . . . .	12

## LIST OF GROUPS

Group	Page	Plate
Main Shaft. . . . .	28	1
Head Shaft. . . . .	30	2
Hook Drive . . . . .	32	3
Hook . . . . .	34	4
Needle Drive. . . . .	36	5
Take-Up Lever . . . . .	38	6
Thread Tension . . . . .	40	7
Skip Stitch Plunger . . . . .	42	8
Cover. . . . .	44	9
Feed, Feed Plate and Plunger, Model 17-10 . . . . .	46	10
Feed, Feed Plate and Plunger, Model 24-12 . . . . .	48	11
Feed Elevating . . . . .	50	12
Feed Driving. . . . .	52	13
Plunger Cradle and Adjusting. . . . .	54	14
Plungers. . . . .	56	15
Knee Press. . . . .	58	16
Work Support Plate. . . . .	60	17
Miscellaneous. . . . .	62	18
Presser Foot, Model 24-12 . . . . .	64	19
Presser Foot for piped edges, Model 17-10. . . . .	66	20
Presser Feet for piped edges, with plow edge guide, Model 17-10. . . . .	68	21
Presser Feet for silks, rayons and knit materials, Model 17-10. . . . .	70	22

# MODELS 17-10 AND 24-12 ARM & BASE GROUPS

## MODEL 24-12 HEAD GROUPS

SEE NEXT PAGE FOR  
MODEL 17-10 HEAD GROUPS

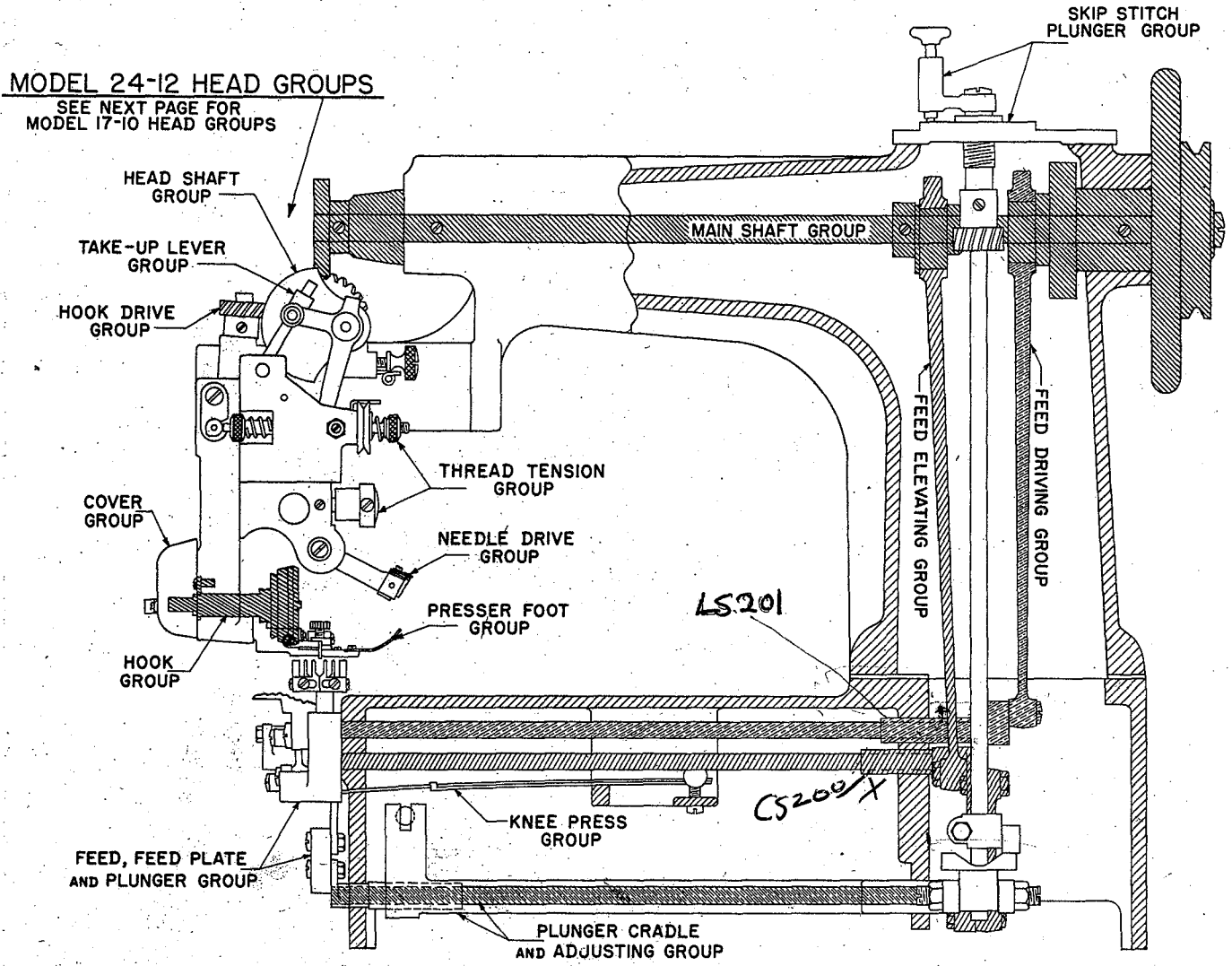

# MODEL 17-10 HEAD GROUPS

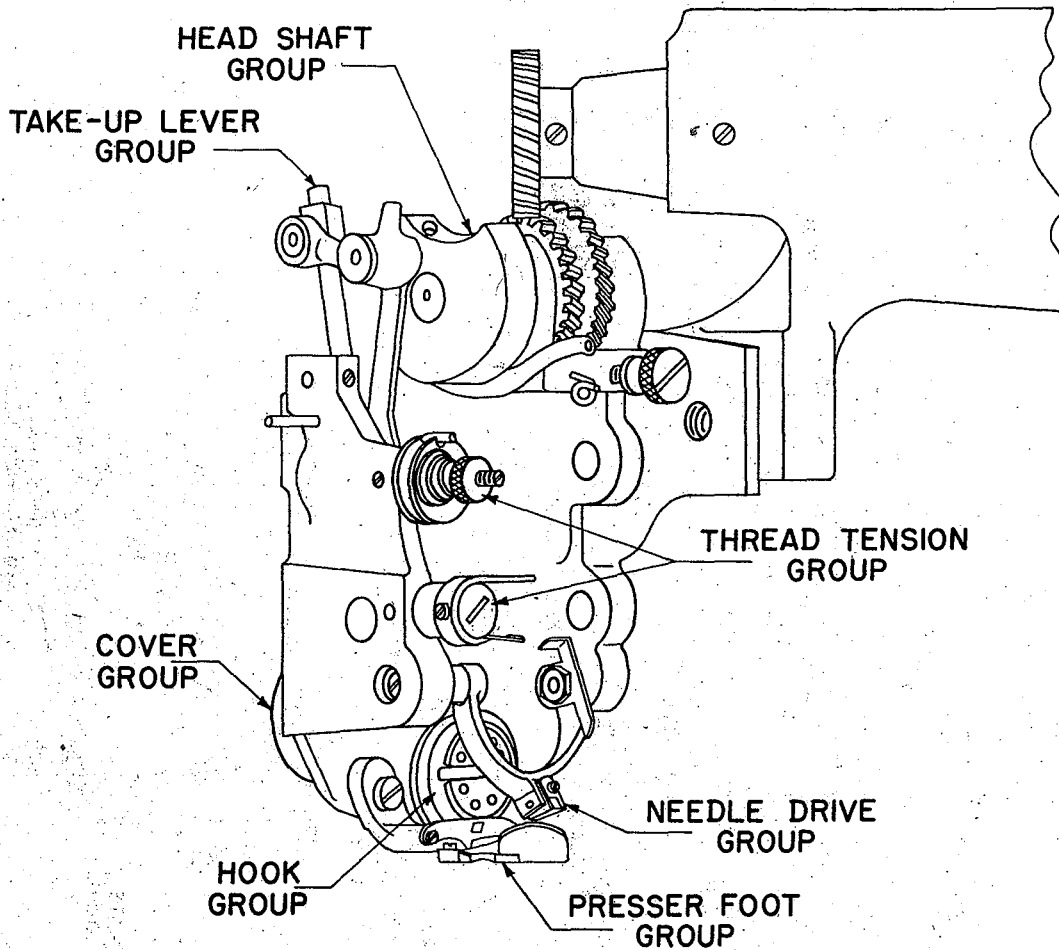

114-154  
102551

des  
ope  
illu  
sub

tity  
whic  
the  
pad  
the  
cove

down  
of th  
by a  
group

Parts  
all th  
part  
deter  
page  
is loc

24-12

flat b  
felling  
under  
with a

bed m

## INSTRUCTIONS FOR OPERATING AND ADJUSTING LEWIS MODEL 17-10 and 24-12 LOCK STITCH MACHINES

1. This catalogue covers the Models 17-10 and 24-12 machines, described on pages 5 and 6. The catalogue is intended to provide operating and adjusting instructions for these models as well as illustrations and descriptions of the parts used. A general index to all subjects covered appears on page 1.

### ORDERING PARTS

2. Order by part number, giving description of the part, quantity needed, and model number and serial number of the machine for which the part is required. The model number is located at the top of the column of the arm. The serial number is stamped into the number pad near the bottom of the column of the arm. On the older machines, the serial number will be found stamped in the arm under the top cover near the hand wheel.

3. To assist in ordering parts, the machine has been broken down into groups (such as presser foot group, hook group, etc.) Each of these groups has been shown in a separate illustration accompanied by a list giving the part numbers and descriptions of the parts in the group. See pages 28 thru 71.

4. If the part number is known, refer to the Numerical list of Parts on pages 72 thru 75 at the back of the catalogue. This list shows all the plate numbers of the groups in which the part is used. If the part number is not known, refer to the illustrations on pages 3 and 4 to determine the group in which the part is located. The list of groups on page 2 will give the number of the page on which the group in question is located.

5. This catalogue covers the following models: 17-10 and 24-12.

6. Lewis Model 17-10 is a 45° two thread lock stitch raised flat bed machine, for operations on men's and women's garments, felling facings and bottoms of coats finished with piping, with turned under edge, or with pinked edge. Machine sews a straight line stitch with a 2-to-1 skip stitch or non skip stitch.

7. Lewis Model 24-12, is a two thread lock stitch raised flat bed machine. Head is set at 90°, for felling together, the canvas and

cloth at the edge of sack coats and overcoats finished with a plain edge, Sometimes referred to as a bluff edge.

### UNPACKING AND SETTING UP

8. To remove the machine from the box, take off the cover and remove the nails and screws that hold the brace blocks in position. Use a nail puller to avoid breaking the machine. These blocks are held by nails or screws driven through the outside of the box. The knee lifter and bobbin winder are attached to the side of the box, and the other small parts will be found wrapped in a package. Be sure to look carefully through the material used for packing before destroying it, so that you will find all the parts and equipment that goes with the machine. Lift the machine out of the box very carefully to avoid breaking the take-up and tension studs as these parts project beyond the head of the machine.

9. To protect the machine from rusting while in transit, all parts are covered with vaseline, which must be carefully wiped off before the machine is put in operation. Take off aluminum head cover by loosening thumb screw. To remove this cover the take-up must be at its lowest point. Use gasoline or petrol to remove the grease from the hook and bobbin case, so as to allow the thread to pass over the hook freely. Also wipe foot, needle and other exposed parts. When shipping machines to distant countries, it is necessary to remove the head mechanism and pack separately, so as to insure delivery in good order. To aid reassembly, the castings and gears are marked with red paint, showing the relative position of the head mechanism on the frame of the machine and also the timing of the gears.

### HAND WHEEL

10. The hand wheel turns away from the operator, that is to say in a clockwise direction when seen from the hand wheel end of the machine.

### OILING AND CLEANING

11. Proper lubrication and thorough cleaning of the machine is of first importance. Lewis Invisible Stitch Machines will give years of service and satisfaction if reasonable care is taken in keeping them properly oiled and cleaned. The machine should be oiled and cleaned



daily as lint and dirt accumulates in the moving parts, causing them to function improperly.

12. In cleaning the machine always remove the cover from the head and wipe off the parts with a clean cloth. Do not use waste. By turning the hand wheel you will see the various moving parts, bearings, gears, etc. and oil holes. A few drops of oil should be placed on these small parts daily. On a new machine it is necessary to place a drop of oil in back of the bobbin case race-way every two or three hours. The hook shaft should be oiled through the hole in the casting to the right of the hook. A drop of oil well placed will do more good than ten drops that do not reach the parts requiring it.

13. Besides thoroughly oiling the head mechanism it is also necessary to lubricate the plunger and feed mechanism. The feed mechanism will be found in the bed of the machine immediately below the presser foot. This mechanism may be uncovered by removing the work plate, or by turning the machine back on the hinges.

14. On all types of machines there are movable parts that require oiling near the base, immediately below the hand wheel. By turning back the machine, several movable parts will be found in the base, all of which require daily lubrication.

15. It is also necessary to oil the machine at the top underneath the plate near the hand wheel Figure O, Page 20.

16. See that the feed points (Figure P) Page 21 are cleaned every day to avoid lint accumulating. Accumulation of lint in the feed points will cause the machine to feed improperly.

#### SPEED

17. Lewis Model 17-10 can be operated up to ~~1500 stitches per~~ minute. A speed of ~~900 to 1200~~ stitches per minute is recommended in starting a new machine or with a new operator.

18. Lewis Model 24-12 can be operated from 900 to 1100 stitches per minute.

#### NEEDLES

19. Needles for Lewis Invisible Stitch Machines are furnished in all necessary sizes with either a taper point or a ball eye. Taper

point needles are recommended for light materials and materials difficult to penetrate. Ball Eye needles are recommended for heavier materials and soft finished materials. If the material has a tendency to hug or ride with the needles on its return stroke, making it impossible to form a good loop, it is a good indication that a Ball Eye needle is required.

20. The selection of the proper size and kind of needle is of first importance. The last whole figure (and fraction if indicated) is the size of the needle, thus 29-133-1/2 is a number 3-1/2 Ball Eye needle for Lewis Class 17 and 24 Machines. The 3-1/2 indicated that the blade of the needle is .035" in diameter.

21. A number 3-1/2 needle will be found satisfactory for work of average weight. For lighter than average material, use a smaller needle, such as a number 3. For heavier than average material, use a larger needle, such as a number 4 or a number 4-1/2. No matter what needle is selected, be sure that the eye is large enough to permit the thread or yarn that is to be used to run freely through the eye of the needle.

22. Needles for Lewis 17-10 and 24-12 machines are furnished in the following sizes:

Taper Point Not Scarfed	Ball Eye Not Scarfed
29-123	29-132-1/2
29-123-1/2	29-133
29-124	29-133-1/2
29-124-1/2	29-134
	29-134-1/2

23. Use ONLY genuine LEWIS Needles. Look for the copyrighted word "LEWIS" stamped on the shank of each needle. All genuine Lewis Invisible Stitch Machine needles have the name Lewis and the correct size stamped on each shank.

THREAD

24. COTTON. Use any good grade of left-twist three cord cord finish cotton in sizes 60 or 70 in the needle. In the bobbin use a finer thread than in the needle. We recommend sizes 80 to 100. If mercerized thread is used, use either "O" or "OO" in the needle and either "OO" or "OOO" in the bobbin.

"OO"

Chart of  
threading  
the thro

the bobbin  
bobbin.

sure that  
side of the  
the adjacent  
the thread  
in the slot  
case. Leave  
inches loose  
With a new  
needle thread  
and the work  
first stitch  
the bobbin  
spring.

29  
is inserted  
case. Open

30.  
final stitch  
will have  
work and  
hand wheel

25. SILK: Use either "O" or "OO" in the needle and either "OO" or "OOO" in the bobbin.

### THREADING MACHINE

26. For threading Models 17-10 and 24-12, see Threading Chart on page 11. Until thoroughly familiar with the process of threading, we recommend that the take-up be at its highest point during the threading.

### INSERTING BOBBIN

27. Turn hand wheel until the needle is farthest away from the bobbin case. Open bobbin case latch, figure A, to discharge empty bobbin.

28. When inserting full bobbin, be sure that the thread unwinds from the underside of the bobbin, as is clearly shown in the adjoining illustration. Hold the end of the thread in the right hand and insert it in the slot on the right side of the bobbin case. Leave the thread three or four inches long on the outside of the bobbin case. With a new operator we suggest that the needle thread be held lightly in the hand and the wheel be turned by hand until the first stitch is completed, which will draw the bobbin thread underneath the tension spring.

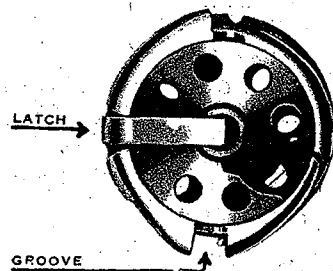

Figure A  
Note that thread unwinds from Underside of Bobbin.

### INSERTING AND REMOVING WORK

29. See that the needle is threaded properly and that the bobbin is inserted correctly. Have the needle farthest away from the bobbin case. Open the knee press and insert the work.

30. To remove work from the machine, first make sure that the final stitch has been completed. This of course means that the hook will have cast off the needle thread. The needle should be out of the work and approximately as far back on its up stroke as it will go. Turn hand wheel by hand backwards about a quarter of a turn to cause the

plunger to drop out of the way. Pull off three or four inches of needle thread from the spool by grasping the needle thread between the needle carrier and the take-up. See page 11. Open the knee press and remove the work by drawing it backwards, not sideways. For convenience the needle and bobbin thread may be cut on the thread clip and cutter mounted on the back of the hook gear cover. See page 44. The ends of both threads will then be properly held for the beginning of the next stitch. The threads will then release themselves as the work progresses through the machine.

31. CAUTION: Do not run machine without material under the presser foot unless the feed point is out of contact with the foot and the needle thread is out of the needle.

### ADJUSTING LENGTH OF STITCH

32. This adjustment is provided at the top of the machine. Turn back the nickled plate next to the hand wheel in order to expose the moving parts, as noted in figure B. Loosen lock screw B by turn-

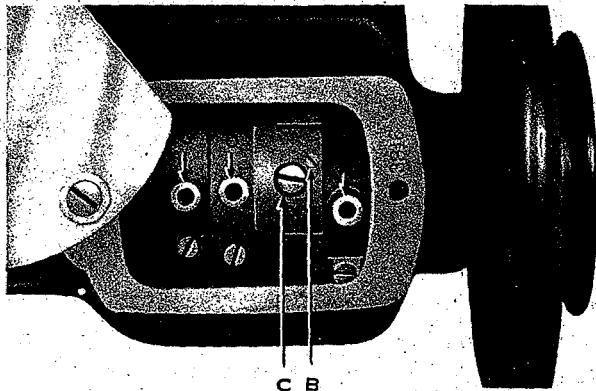

Figure B

ing to the left. If the stitch is to be lengthened, turn screw C to the left. To shorten stitch turn screw C to the right. When adjustment is completed, tighten securely lock screw B, which makes the adjustment permanent.



Turn to the right



Turn to the left

24. To avoid misunderstanding regarding instructions "Turn to the Right" and "Turn to the Left" we have inserted the above arrows showing what these expressions mean.

# THREADING CHART

MODELS  
17-10  
24-12

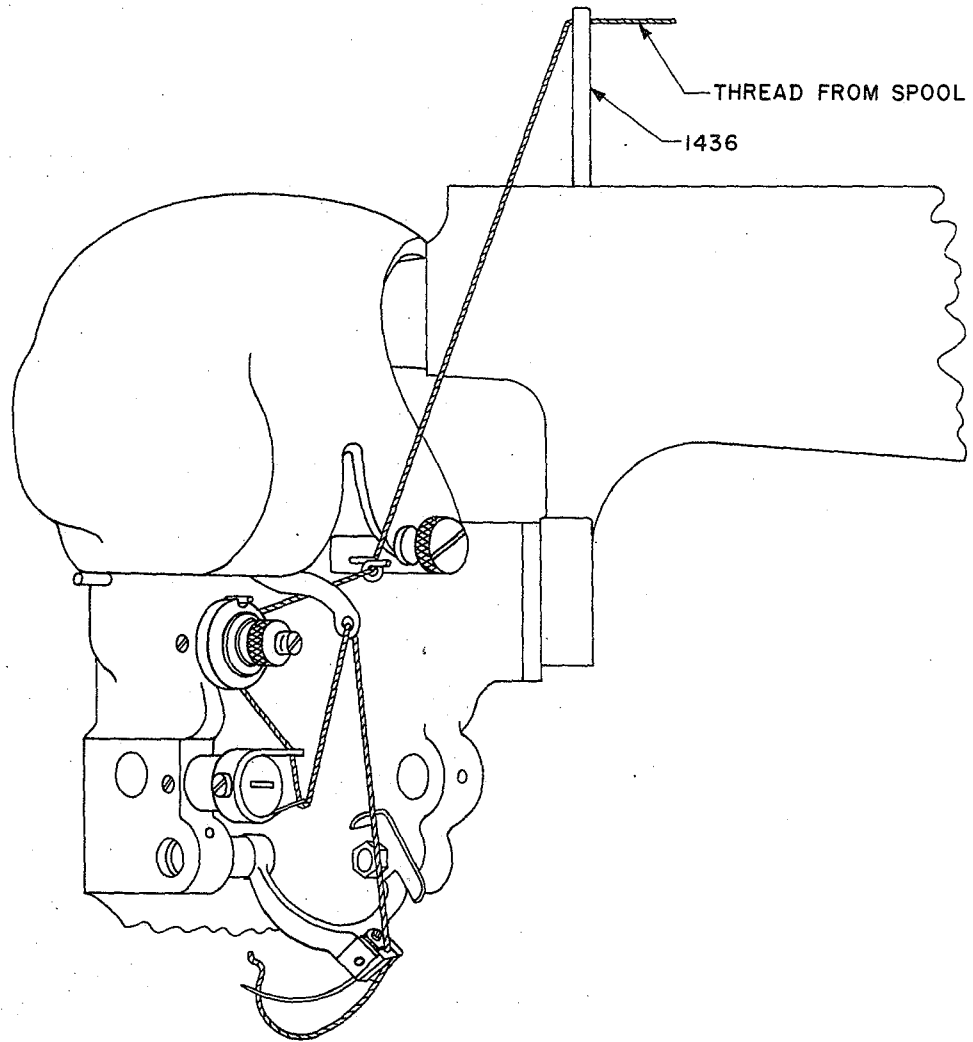

THREAD FROM SPOOL

1436

114-154  
102551

## ADJUSTING THREAD TENSIONS

34. The tension on the needle thread is adjusted by turning thumb nut 20-60, Figure C, to the right or to the left. This tension should be set sufficiently tight to make a firm stitch. Do not, however, make this adjustment too tight, because by so doing the thread will draw the goods and leave an impression or dimple on the face of the goods. Also thread breakage may result if the needle thread tension is set either too loose or too tight.

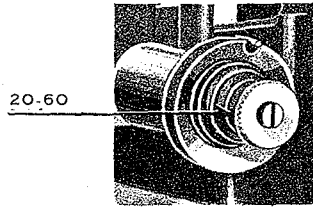

Figure C

35. The tension on the bobbin thread is adjusted by means of screw 1046, Figure D. By turning this screw to the right, the tension is set tighter as it presses the bobbin case spring more firmly against the thread. This tension should be set rather loose so as to permit the thread to draw off the bobbin freely with very little resistance. Experience on various kinds and grades of work will show best what tension produces the desired results.

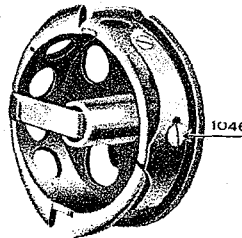

Figure D

## ADJUSTING WIDTH OF BIGHT

36. The width of bight taken by the needle depends on several things, the "angle" of the machine being the most important. Thus a 45° machine will produce a wider bight than a 15° machine, other conditions being equal. The width of the bight is also dependent on the depth to which the needle penetrates the goods as well as the shape of the top of the plunger. For any given set of these conditions, the width of bight may be adjusted by moving the edge guide, Figure E, to the right or to the left by loosening the set screw which holds this part in position. By moving the guide to the left, a wider bight will result, to the right will produce a narrower bight.

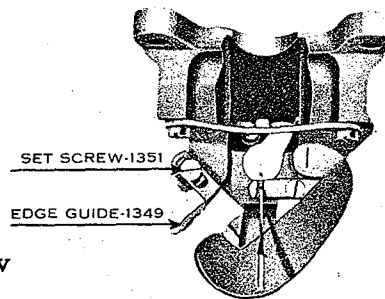

Figure E

is a  
weig  
by s  
LS 3  
appl  
year  
to th  
both  
the f  
come

whee

of the  
foot v

the pl  
lifter  
frame  
screw  
bobbin  
in the  
positi

bobbin  
bobbin  
which  
bobbin  
latch;  
which

## ADJUSTING FEED PLATE PRESSURE

See Plate 16 Page 58

37. The feed plate which holds the cloth firmly against the foot is adjusted at the factory with the proper pressure for handling all weights and kinds of work. The pressure on the feed plate is applied by spring LS 405, which is adjusted with feed spring adjustment screw LS 394. While this adjustment is rarely used, it may be necessary to apply more pressure after the machine has been in service for many years. By turning screw LS 394 to the right more pressure is applied to the feed plate and feed point. The feed plate should bear equally on both sides of the presser foot. A thin piece of paper placed between the foot and the feed plate is useful for checking this in case it becomes necessary to install a new feed plate.

## REMOVING AND REPLACING PRESSER FEET

38. In order to remove or exchange presser feet, turn hand wheel until the plunger is at the lowest point. Remove needle.

39. Remove both screws 1073, which hold the foot on the frame of the machine. Press knee lifter so as to release the pressure on the foot which, in turn, releases the presser foot.

40. To insert foot, do not change the position of the plunger or turn the hand wheel, Press the knee lifter, which permits placing the foot in position on the frame of the machine. Replace and tighten the two screws 1073. Be sure to see that the groove in the bobbin case, Figure A, Page 9 fits over the projection in the bobbin case retainer, Figure F. This holds the bobbin case in position.



Figure F

## REPLACING BOBBIN CASE

41. Should the thread become caught or tangled in back of the bobbin case, causing the machine to lock, it is necessary to remove the bobbin case, inasmuch as the bobbin case latch, Figure A, Page 9, which holds the bobbin in position, cannot be raised to release the bobbin. Under no circumstances use force to open the bobbin case latch; by so doing the latch or spring will very likely become broken, which means the expense of a new bobbin case.

42. To remove bobbin case, we recommend that the presser foot be removed first as per instructions in Paragraphs 38 and 39.

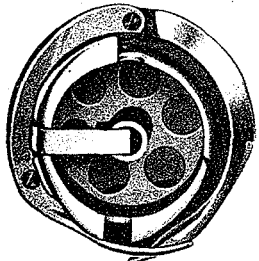

Figure G  
Correct Position  
of Hook for Re-  
moving Gib Screws  
and Gib.

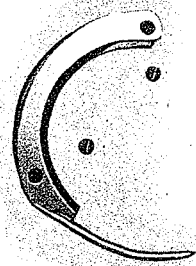

Figure H  
Gib and Screws  
Removed for  
Bobbin Case  
Replacement.

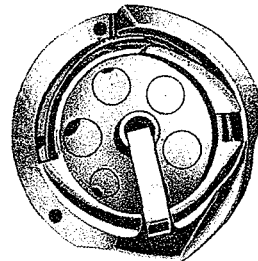

Figure I  
Relative Position  
of the Latch to the  
Point of the Hook  
For Removing  
Bobbin Case.

43. See that the point of the hook is at its lowest point as per illustration above. Then remove both gib screws 1039 which holds gib 1037 in position on the hook. See Figure H. After removing gib, turn bobbin case to the left one-quarter turn. This releases the bobbin case from the hook.

44. Inasmuch as the bobbin case fits snugly in the raceway of the hook, it may be necessary to use slight pressure to cause it to release. Use fingers only to remove the bobbin case and do not insert screw driver or any other object as a lever, as this is apt to break the bobbin case. To insert bobbin case in hook, see that the latch is in line with the point of the hook as per illustration, Figure I. Replace hook gib in position, and securely tighten screws 1039. Turn bobbin case so that the groove, Figure A, is at the bottom and fits into the notch on the bobbin case retainer as noted in paragraph 40.

### REPLACING AND TIMING HOOK

45. Remove gear cap 1072, which is in back of the machine in line with the hook. Remove gear 1030, Plate 3, Page 32, by loosening both screws holding same. Remove needle and presser foot, as per instructions in Paragraphs 38 and 39. Remove Bobbin case release 445-251 by removing screw which holds same in position. With these various parts out of the way, the hook can be withdrawn from

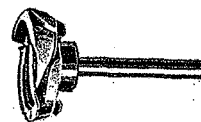

Figure J  
Hook 1040A

the  
add  
not.  
and  
Fig  
hav  
ma.  
in t  
str.  
on  
the  
fit  
sha  
hoc  
the  
the  
thr  
cor  
be  
scr  
pos  
to t  
the  
the  
up  
slo  
Tig  
wit  
  
wil  
l/  
ret  
car  
tha  
  
coi  
  
fac  
ne



the machine. See Plate 4, Page 34.

46. To replace the hook preceding instruction apply, with the added caution regarding timing the hook. This is a simple matter by noting the lines on both the upper and lower gears 1028 and 1030.

Figure K. Both of these gears have lines which must meet and make a straight line. The groove in the hook shaft must also be in straight line with the two lines on gears 1028 and 1030, so that the point of spot screw 1031 will fit into the groove on the hook shaft. When inserting a new hook, the groove may not be in the same relative position as in the one removed, which will throw the hook out of time. To complete the adjustment it may be necessary to loosen the two screws that hold gear 1028 in position. Turn the hook slightly to the right in order to pick up the thread loop more quickly from the needle; or turn the hook pick up the needle thread loop more slowly, whichever may be required.

Tighten the two screws in gear 1028, making sure this gear runs freely with gear 1030 but without excessive backlash.

47. You will note that the point of the hook when properly timed, will be at its lowest point or immediately above the needle and about 1/16 of an inch from the eye of the needle when the needle is on its return or back stroke. In this, as with all other adjustments, be very careful to see that all screws are securely tightened and any parts that have been removed are carefully replaces in position.

**CAUTION:** Before timing hook, make sure that needle is correctly timed with plunger, see paragraph 53, page 17.

#### RAISING AND LOWERING HOOK

48. The height of the hook relative to the needle is set at the factory and generally requires no adjustment. In case it does become necessary to change the height of the hook, remove gear 1030, Figure

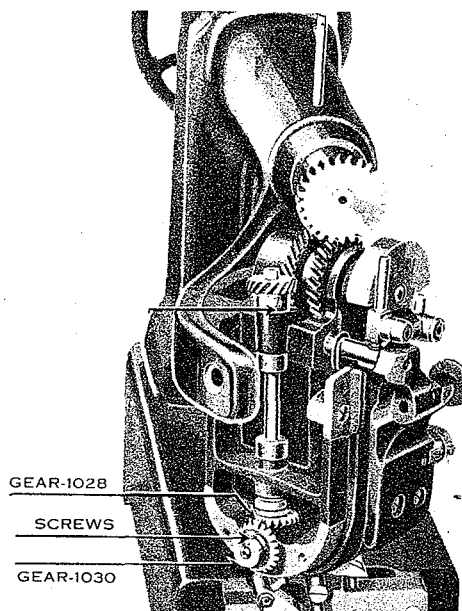

Figure K

K. This will reveal a screw that holds the hook bushing in position through the flange on the bushing. This bushing is eccentric and turning it will change the height of the hook. Two holes are provided for the screw, thus giving a wide range of adjustment.

#### BOBBIN CASE RELEASE

See Plate 4 Page 34

49. Bobbin case release 445-251 is operated by the lever mounted on the needle carrier. This release should be adjusted so that the needle thread passes freely over the top of the bobbin case, and so that the needle thread passes freely between the bobbin case and the bobbin case retainer, Figure F, Page 13 after the needle thread drops off the beak of the hook. The setting of the bobbin case release should always be checked after changing the height of the hook.

#### THREAD CONTROLLER SPRING

Model 17-10

50. The thread controller spring 1187, Plate 7 Page 40 may be adjusted by loosening screw LS 330 and turning staff 68-19 to the right to increase the tension and to the left to decrease the tension. Hold staff 68-19 in position with the screw driver and tighten screw LS 330. This makes the adjustment permanent.

51. If the needle thread snaps as it passes over the top of the bobbin case, it is an indication that either the tension on the thread controller spring is too great or that the hook is a trifle slow, or both. If the tension on the thread controller spring is not great enough, the thread will not come off the hook fast enough with the result that the hook will pick up the thread a second time causing the machine to break thread.

#### THREAD CONTROLLER SPRING

Model 24-12

52. See automatic tension release Plate 7 Page 40 and description on Pages 24 and 25.

mai  
han  
the  
full  
14-  
nee  
the  
nee  
aga.  
Whe  
of a  
repi  
spot  
the  
adju  
spot  
on t  
scre

you  
full  
plun

whil  
pene  
you  
good  
for t

of it:  
open

with  
slide  
the p

## TIMING NEEDLE WITH PLUNGER

53. Loosen both screws L and M, Figure L, which hold the main shaft head driving gear N in position. Remove gear N. Turn handwheel away from you slowly until the plunger is at its highest point, at a full stop. The groove in main shaft 14-324 should now be on top. Turn needle crank 1001 in the direction of the arrow stamped on it, until the needle is at its highest point and is again returning towards the plunger. When the point of the needle is  $\frac{1}{4}$  of an inch (6mm) from the plunger, replace gear N on the shaft so that spot screw L will enter the groove in the shaft without disturbing previous adjustments. Be sure to see that the spot screw L is in line with the groove on the shaft before tightening this screw.

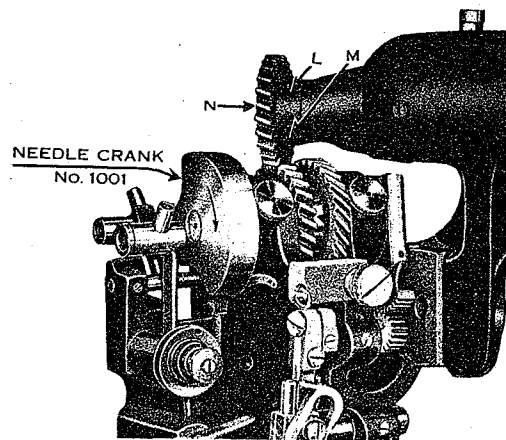

Figure L

54. To test this adjustment, turn hand wheel slowly away from you and note if plunger is raised to its highest point and comes to a full stop as the point of the needle is  $\frac{1}{4}$  of an inch away from the plunger, about to enter the goods.

55. We call to your attention that the plunger must not move while the needle enters the goods. After the needle has made the penetration and the hook has picked up the thread loop from the needle, you will note that the plunger again recedes in order to release the goods, thereby permitting the feed to carry the goods forward, ready for the next stitch.

## REMOVING PLUNGER

56. Loosen both nuts 1311, Figure M, and the plunger releases of its own accord and may be removed by raising it up through the opening in the presser foot.

57. To insert new plunger, place same in the plunger barrel with the groove in the plunger to the front. The groove in the plunger slides on the notch on the inside of the plunger barrel, thereby keeping the plunger from turning.

58. Turn hand wheel until the plunger recedes to its lowest point. Press the knee lift pad 1383, Plate 16 Page 58, in order to allow the insertion of a screw driver or other flat metal object between the plunger and the presser foot. This is necessary in order to hold the plunger down against the plunger spring. Turn hand wheel away from you one-half turn, thereby causing the threaded end of the plunger to pass down through the plunger barrel.

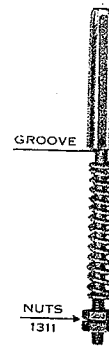

Figure M

59. Replace equalizing spring 1368OS, replace nuts 1311 on the end of the plunger and lock them together. Nuts 1311 should be set near the lower end of the plunger only sufficiently high to hold them securely on the stem, as noted on Figure M. If the nuts are set too high on the plunger, the plunger will not raise sufficiently high to meet the needle penetration. Nuts 1311 must also be set so that when the plunger is at its highest point and when plunger adjustment knob LS 219 Figure N, page 19, is turned so that the plunger is at its highest adjustment, the plunger should raise the needle about 1/64 of an inch from the needle guide. Check to see that the needle cannot strike the side of the plunger. Be very careful to see that the lower nut is tightened against the upper nut to prevent loosening.

#### REMOVING PLUNGER & PLUNGER BARREL Model 17-10

60. Refer to Plate 10, Page 46.

To replace or change plungers, loosen nut 1160 and remove bearing screw LS 302, and link 1304. Barrel with plunger will pass the crank LS 165A by turning the barrel one quarter turn.

#### REMOVING PLUNGER & PLUNGER BARREL Model 24-12

61. Refer to Plate 11, Page 48.

To replace or change plungers, loosen the two nuts 1160, and remove the two screws 1251, and roll LS 207. Turn plunger barrel 470-6 one quarter turn and remove from the machine.

fo  
tr  
Th  
of  
ap  
eq  
un

Mc  
fel  
Fig  
the  
per  
dec  
the  
dec  
lev  
set  
ma

des  
17-  
stit  
stit  
fab

LS  
fou  
hole  
2-to  
stit

## INSTRUCTIONS FOR ADJUSTING Model 17-10 Machines

62. Lewis Model 17-10 Machines are adjusted at the factory for 2-to-1 stitching. By this we mean that every second stitch penetrates the lower fabric, producing a stitch similar to hand-felling. This kind of stitching is generally used for felling facings and bottoms of quarterlined, half lined and skeleton lined coats. The 2-to-1 stitch appears under the binding (see illustration). It may be used with equally good success on edges finished either with piping or turned under.

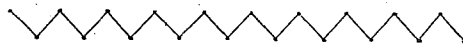

### ADJUSTMENTS OF THE PLUNGER FOR 2-to-1 STRAIGHT FELLING STITCH

63. In order to adjust the Model 17-10 machine for 2-to-1 felling, use adjustment LS 74; Figure O. By turning LS 74 to the right of the needle will penetrate the lower goods more deeply; by turning to the left the needle will penetrate less deeply. The point of adjustment lever LS 74 should always be set in one of the holes so as to make the adjustment permanent.

64. Occasionally it is desirable to use the Model 17-10 Machine for straight stitch felling, whereby every stitch catches in the under fabric as

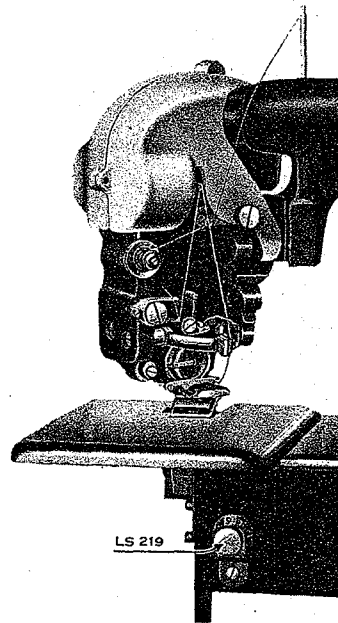

Figure N

65. To adjust machine for straight felling raise adjustment pin LS 74, Figure N and turn to the left several times - generally from four to six turns - until the base of the pin rests lightly in one of the holes sufficient only to keep LS 74 from turning. This throws the 2-to-1 stitch adjustment out of operation, producing a straight felling stitch.

66. In order to obtain the proper depth of needle penetration, after adjusting machine for straight felling stitch, place a single thickness of the goods to be felled under the presser foot. Turn hand wheel away from you slowly and watch the action of the needle as it penetrates the cloth. The needle should enter the goods sufficient to only pick up a few strands of the material and not penetrate deep enough to show an impression on the under side or facing side of the goods. If the needle passes over the goods and does not make proper penetration, turn the plunger adjustment knob LS 219, Figure N, to the right. If needle penetrates too deeply turn the plunger adjustment LS 219 to the left.

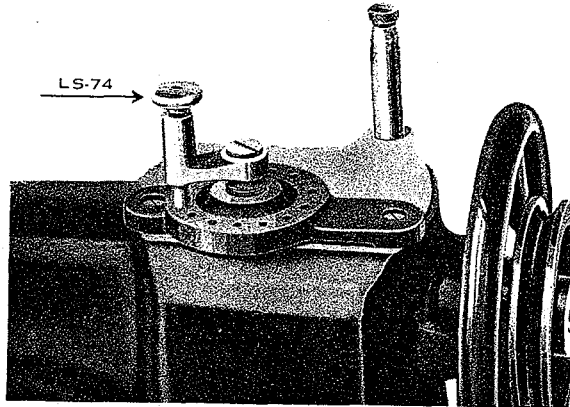

Figure O

67. In changing machine from straight felling stitch to 2-to-1 stitch the reverse of the preceding instructions will apply. Place a thickness of material under the presser foot and turn plunger adjustment LS 219, Figure M, to the left until the needle slides over the surface of the goods without penetrating it. Then turn adjustment pin LS 74, Figure N, to the right until the needle penetrates the single thickness of material slightly.

68. Turn hand wheel from you slowly and watch the needle as it penetrates the goods several stitches. If the needle does not penetrate through less than half the thickness of the goods turn adjustment pin LS 74 slightly to the right until the proper depth of needle penetration is attained. If the needle penetrates too deeply, turn adjustment pin LS 74 to the left. You will note that only a very slight movement of LS 74 is required in making this fine adjustment.

#### FITTING MACHINE FOR SACK COATS OR OVERCOATS

69. Lewis Model 17-10 machines are fitted at the factory for work on sack coats, unless otherwise ordered. The machine is equipped with presser foot 1343SA (See Plate 20 Page 66), which will accommodate all light and medium weight fabrics used in sack coats and light overcoats and finished with either piped edges or turned under edges.

70. For work on overcoats the machine must be fitted with presser foot 1373SA, which is adapted for handling heavy materials.

71. On extra fine tailoring we recommend using special presser foot 405-1, 405-2 or 405-3. These feet are designed to raise the edge of the piping sufficient to entirely cover the needle thread under the piping, which otherwise may be visible on close examination. Foot 405-1 is used for work on sack coats and light overcoats; foot 405-2 is used for work on heavy overcoats, and foot 405-3 is used for medium and medium heavy work.

#### RAISING AND LOWERING FEED POINT

72. Lewis Invisible Stitch Machines are adjusted at the factory for properly feeding all kinds and weights of material which they are designed to handle. However, there may be occasion when extremely heavy overcoats are to be handled, garments made with thick cumbersome seams or extremely heavy pockets and reinforcements to pass over, which requires a slight raising of the feed point, Figure P.

73. On this class of work the operator may find it necessary to assist the work through the machine by drawing the goods from the back, and if considerable heavy work is to be handled for any length of time it is advisable to raise the feed point slightly.



Figure P

74. To do this, turn the machine back on the table, turn hand wheel away from you until the feed plate rests against the bottom of the foot. Continue turning the hand wheel slowly until the feed point has receded to its lowest position. Loosen screw LS 301 in LS 21A, Plate 12, Page 50, and raise feed point very slightly, not more than  $1/32$  of an inch. Retighten screw LS 301. If feed point is set too high, the top of the feed elevating link 46-94 will strike against feed plate, which in turn will retard the movement of the goods.

#### INSTRUCTIONS FOR OPERATING & ADJUSTING MODEL 24-12 PLAIN EDGE MACHINE

75. All instructions on Model 17-10 apply to Model 24-12, with the following special instructions added:

### BASTING

76. We recommend all edge basting work be done by machine and not by hand. Machine basting places the stitches closer together and the line of basting is more even than ordinarily can be attained with hand basting. Furthermore, machine basting is more economical and the production is far greater.

77. Baste sack coats 1/4 inch from the edge and overcoats 5/16 inch from the edge.

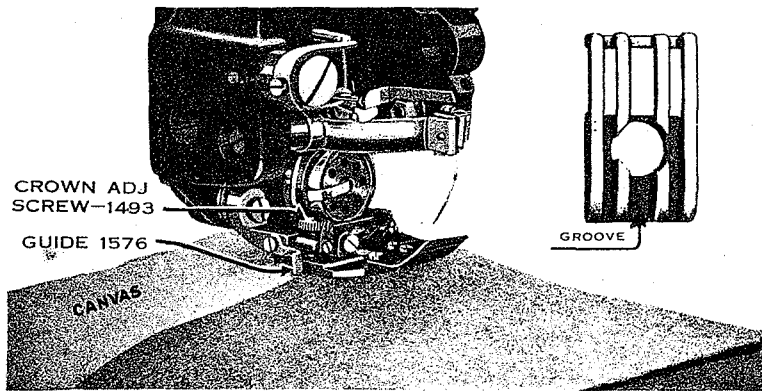

Figure Q

78. In placing the work on the machine, place the garment with the canvas on the left of the arm, which is on the outside of the machine, as shown in Figure Q. See that guide No. 1576 is directly above the basting seam, which is the seam between the canvas and the facing side.

79. Place the edge of the garment in the groove of plate Figure Q, which is directly under the foot.

### NEEDLE PENETRATION

80. The operation of felling the canvas to the coat front is that of joining the canvas to the facing with a zig-zag stitch. This stitch is formed by taking one stitch into the canvas only and alternating with one stitch through one-half the thickness of the goods and through the canvas, giving the appearance of sketch shown at top of page 23.

81. To adjust needle penetration in the cloth on the facing side, use adjustment pin LS 74, Figure N. Turn to the right to make the felling stitch deeper and to the left for less penetration.

adju:  
whic  
crow  
allow

adju:  
throu  
deep  
again  
unles  
finis

pene  
ing f  
slide

are f  
coat:

coat:

SAC  
1 15'  
1 15'  
1 15'  
1 15'



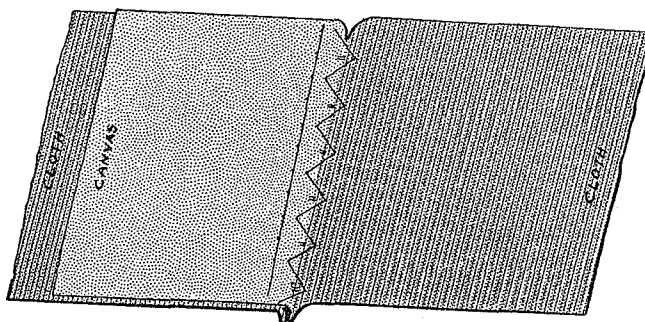

82. To adjust needle penetration in the canvas, turn crown adjustment screw 1493, Figure Q, to the right to stop the plunger rise, which, in turn, causes the needle to penetrate less deeply. Turning crown adjusting screw 1493 to the left tends to raise the plunger, which allows the needle to penetrate more deeply into the canvas.

83. On overcoats it is especially desirable to make the above adjustment so as to permit needle to pass through the canvas and through part of the undergoods on the canvas side. On sack coats this deep penetration is not necessary or desirable, and should be guarded against. The needle should not enter the fore-part on sack coats unless you desire to produce what is termed as a "pricked edge" finish.

84. If the needle penetrates the facing at the time it should penetrate the canvas only, lower the plunger by turning plunger adjusting knob LS 219, Figure M, to the left sufficient to permit the needle to slide over the facing goods.

85. Lewis Model 24-12 machines, unless otherwise specified, are fitted with presser foot 1571A and relating parts for work on sack coats.

86. Parts for changing Lewis Model 24-12 machine from sack coats to overcoats and vice versa are as follows:

SACK COAT PARTS	TOPCOAT PARTS	OVERCOAT PARTS
1 1571A - Foot	1 1593A - Foot	1593SA - Foot
1 1578) Plunger	1 1591) Plunger	1591-1/2) Plunger
1 1579) Complete	1 1592) Complete	1592-1/2) Complete
1 1584 Plunger Spring	1 1310 Plunger Spring	1310 Plunger Spring

## AUTOMATIC TENSION RELEASE

See Plate 7 Page 40

87. A special mechanism used on Lewis Model 24-12 Machine.

88. The purpose of the automatic intermittent tension release is to prevent dimples or indentations from showing on the outside or face side of the material when felling or blind stitching two pieces of cloth together. This mechanism is especially desirable when felling thin light-weight goods.

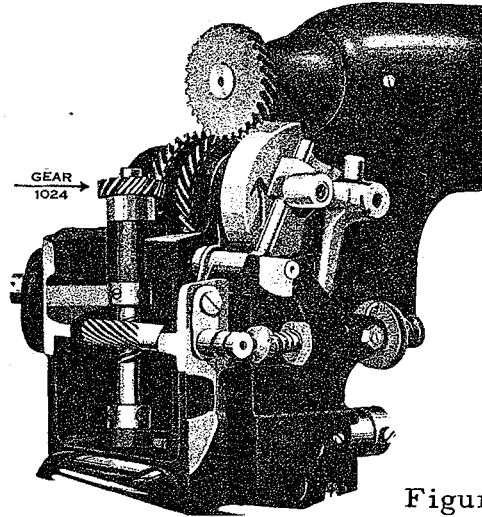

Figure R

89. To avoid indentations or dimples the stitch that is taken in the canvas

portion is made with a normal tension and the stitch that is taken in the facing is made with a very loose tension in order to allow sufficient thread between the two layers of material. In other words, the facing and the canvas are not drawn tightly together through the operation of the automatic tension release.

90. The purpose in setting the stitch in the canvas with a normal tension is to securely fasten the bobbin thread and to prevent the stitches from loosening. While the stitch is taken in the facing the thread is held under normal tension until the hook has discharged the loop when the tension automatically is released, giving the thread which holds the two layers together a very loose tension.

91. CAUTION: Do Not under any circumstances, loosen set screws in gear 1024, Figure R, above indicated by arrow in the illustration. We especially caution you on this, as to loosen gear 1024 means throwing the automatic tension release out of time, which mechanism is properly timed when the machine is assembled in our factory.

92. In case it does become necessary to time the automatic tension release, this timing is done by loosening the screws in gear 1024. Adjustment is then made until the results outlined in Paragraph 90 are obtained. An approximate method of making this adjustment is to note that when the take-up is at its highest point, the single lobe of the cam on the end of shaft 1552 should be horizontal and against

tensio  
it will

which  
K, as

the nee  
edge is  
causin  
occurs  
guide,  
very s  
guide i  
smooth  
elimin:

through  
sharp.  
and thr  
needle.

tight in  
same t  
bind in

14, is i  
the loop  
48 Page  
correct

tangled

may be  
as per i

needle t

tension staff 1553 (See Plate 7, page 40). After making this adjustment, it will generally be necessary to retime the hook.

93. The timing of the hook, which is actuated by the shaft on which gear 1024 is mounted, is provided by the lower gear 1028, Figure K, as per instructions in paragraphs 45, 46, 47.

#### THREAD BREAKAGE: HOW TO OVERCOME

94. After considerable service the needle will be inclined to cut a sharp edge in the groove of the needle guide, causing thread breakage. When this occurs, we recommend replacing needle guide, Figure S which can be done at a very small cost. However, if new needle guide is not conveniently procurable, smooth the groove with emery cloth to eliminate sharpness.

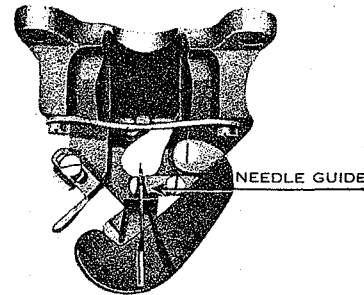

Figure S

95. When thread breakage occurs, check up on the parts through or over which the thread passes, to see if they have become sharp. We refer to the following parts: needle guide, needle clamp and thread guide, thread take-up, bobbin case retainer 1057 and the needle.

96. Thread breakage may be caused by the bobbin being too tight in the bobbin case. While this is not a frequent condition, at the same time as the bobbin becomes old, it has a tendency to warp and bind in the bobbin case. Old bobbins should be discarded.

97. Thread breakage may be caused if the hook, Figure J, page 14, is improperly timed, causing the point of the hook to fail to pick up the loop from the needle at the proper time. See Paragraphs 46, 47, 48 Page 15 for timing the hook. Before timing hook, see that needle is correctly timed to plunger. See Paragraphs 53, 54, and 55 Page 17.

98. If the bobbin is wound too full, or if the thread has become tangled in the bobbin, thread breakage will result.

99. On a new machine just put in operation, thread breakage may be due to accumulation of oil in the hook which must be removed as per instructions in Paragraph 9.

100. Thread breakage may also result if the tension of the needle thread is either too loose or too tight. Check up on this.

20

101. If the hook picks up the needle thread on the hook's second revolution, that is to say, if the hook again picks up the needle thread after just discharging it, or if the hook completely fails to discharge the needle thread, thread breakage will result. These "second revolution" breaks may be due to several things, among which are: the hook is too fast, insufficient tension on the needle thread, insufficient tension on the thread controller spring, or a combination of these.

### SKIPPING STITCHES

102. If the goods are not being properly clamped under the foot, they will ride with the needle as it penetrates, preventing the formation of a good loop for the hook to pick up, and skipping stitches may result. See Paragraph 37 Page 13.

103. Bent or blunt needles are frequently the cause of skipped stitches. Always use a sharp needle and see that it bears on the needle guide while entering the goods. Of course, when the needle is completely in the goods, there should be clearance between the needle and the needle guide.

104. Occasionally the plunger may be the cause of skipped stitches due to its being set too low. Adjust the plunger higher. See Paragraphs 63 and 80-84.



# MAIN SHAFT GROUP

## MODELS

17-10  
24-12

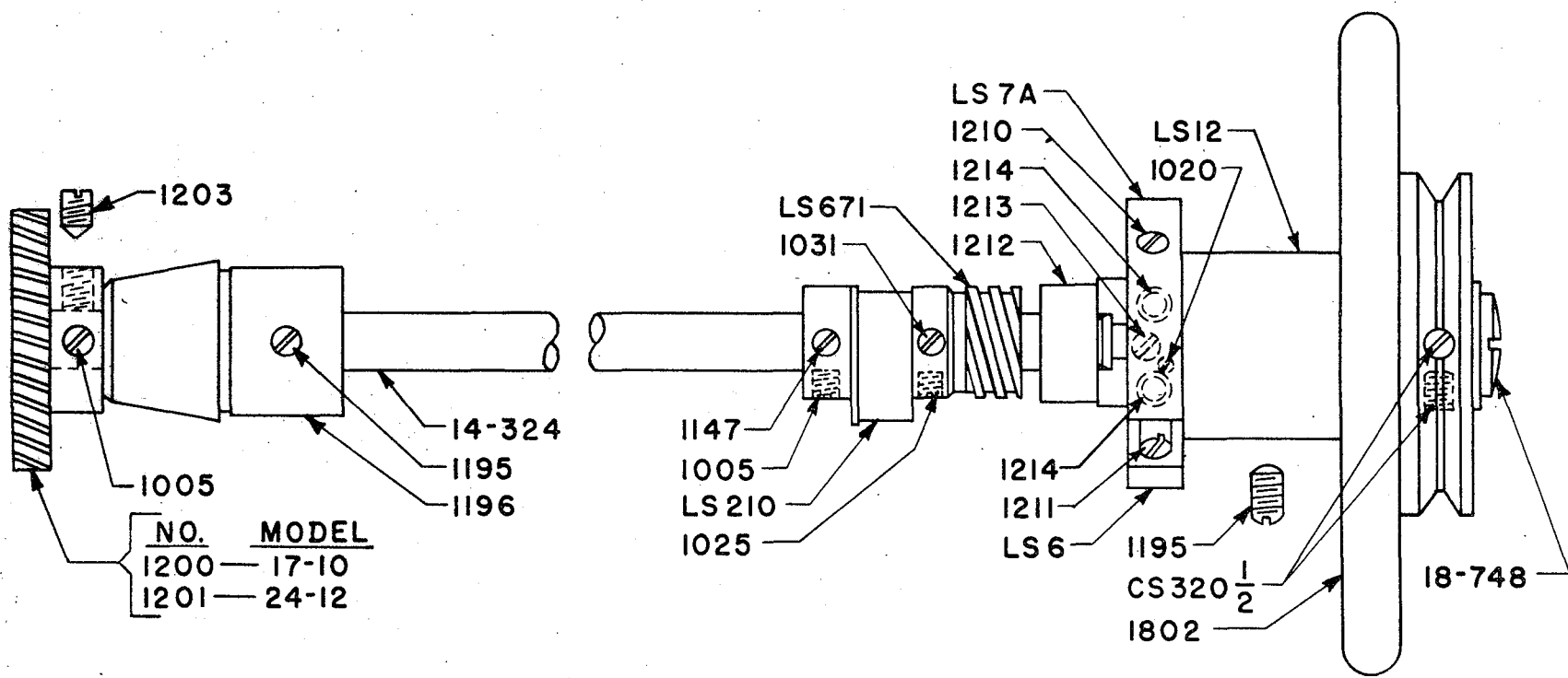

PLATE 1

114-154  
102551

MAIN SHAFT GROUP  
Models 17-10 and 24-12

LS 6	Feed Adjuster Crank Disc, Not Sold.	1196	Main Shaft Bushing, left.
	See LS7A.	1200	Gear on Main Shaft for Driving head, Model 17-10.
LS 7A	Feed adjuster crank disc assembly, composed of: LS 6, and Guide Pin 1208.	1201	Gear on Main Shaft for Driving head, Model 24-12.
LS 12	Main Shaft Bushing, right.		Spot Screw for 1200 and 1201.
LS 210	Feed Elevating Eccentric.	1203	Spot Screw for LS 7A.
CS 320-1/2	Set Screws for Hand Wheel 1802.	1210	Set Screw for LS 7A.
LS 671	Vertical Plunger Shaft Driving Gear.	1211	Feed Adjuster Eccentric.
1005	Set Screw for LS 210.	1212	Screw for adjusting 1212.
	Set Screw for Gear 1200 and 1201.	1213	Spring for 1212, (2) used.
1020	Set Screw to lock Feed Eccentric 1212.	1214	Hand Wheel.
1025	Set Screw for Gear LS 671.	1802	Main Shaft.
1031	Spot Screw for Gear LS 671.	14-324	Screw (left hand thread) in end of Main Shaft.
1147	Spot Screw for Feed Eccentric LS 210.	18-748	
1195	Set Screw in Arm for LS 12.		
	Set Screw in Arm for 1196.		

# HEAD SHAFT GROUP

## MODELS

17-10  
24-12

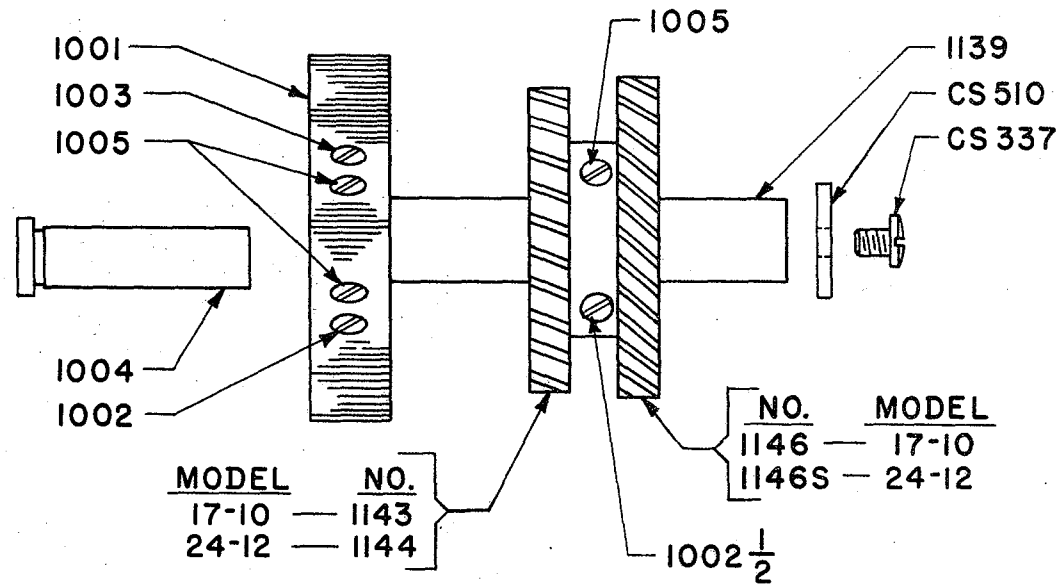

PLATE 2

114-154

102551



HEAD SHAFT GROUP  
Models 17-10 and 24-12

CS 337	Clamp Screw for Washer CS 510.
CS 510	End Thrust Washer for 1139.
1001	Needle Crank.
1002	Spot Screw for 1001.
1002-1/2	Spot Screw for Gears 1143, 1144, 1146 and 1146S.
1003	Set Screw for 1001.
1004	Needle Driving Stud.
1005	Set Screws for 1004.
	Set Screw for Gears, 1143, 1144, 1146 and 1146S.
1139	Head Main Shaft
1143	Head Main Shaft Drive Gear, Model 17-10.
1144	Head Main Shaft Drive Gear, Model 24-12.
1146	Head Main Shaft Hook Drive Gear, for Model 17-10.
1146S	Head Main Shaft Hook Drive Gear, for Model 24-12.

# HOOK DRIVE GROUP

## MODELS

17-10  
24-12

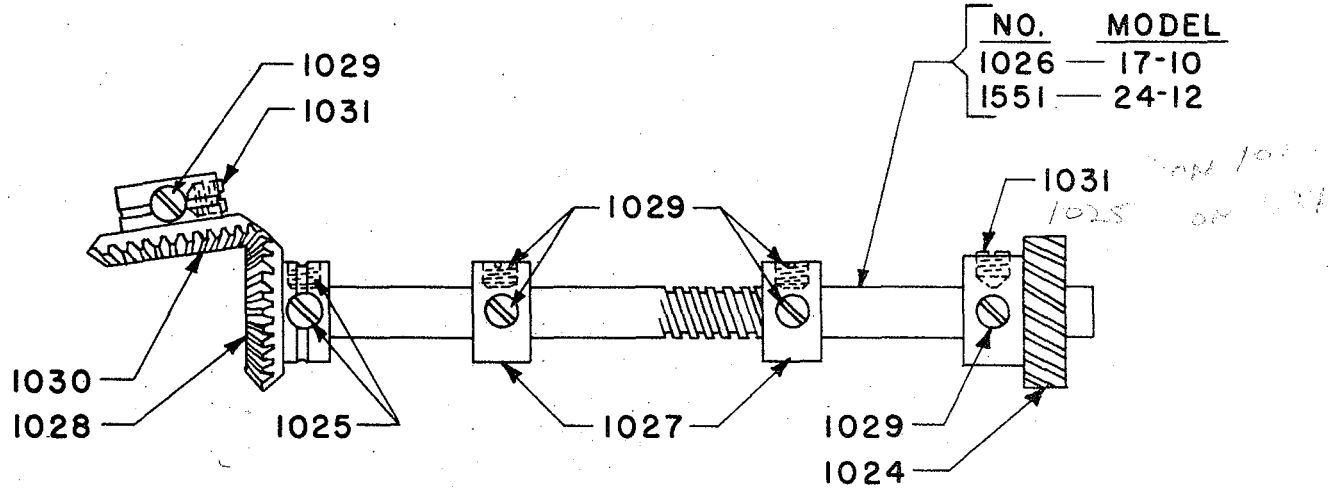

PLATE 3

114-154  
102551

HOOK DRIVE GROUP  
Models 17-10 and 24-12

1024	Hook Spiral Gear.
1025	Set Screws for Bevel Gear 1028.
1026	Hook Timing Shaft for Model 17-10.
1027	Collar for Hook Timing Shaft (2) used.
1028	Bevel Gear on Shaft 1026 and 1551.
1029	Set Screw for Bevel Gear 1030. Set Screw for Collars 1027 (4) used. Set Screw for Gear 1024.
1030	Hook Shaft Bevel Gear.
1031	Spot Screw for 1030 and 1024.
1551	Hook Timing Shaft for Model 24-12.

# HOOK GROUP

## MODELS

17-10  
24-12

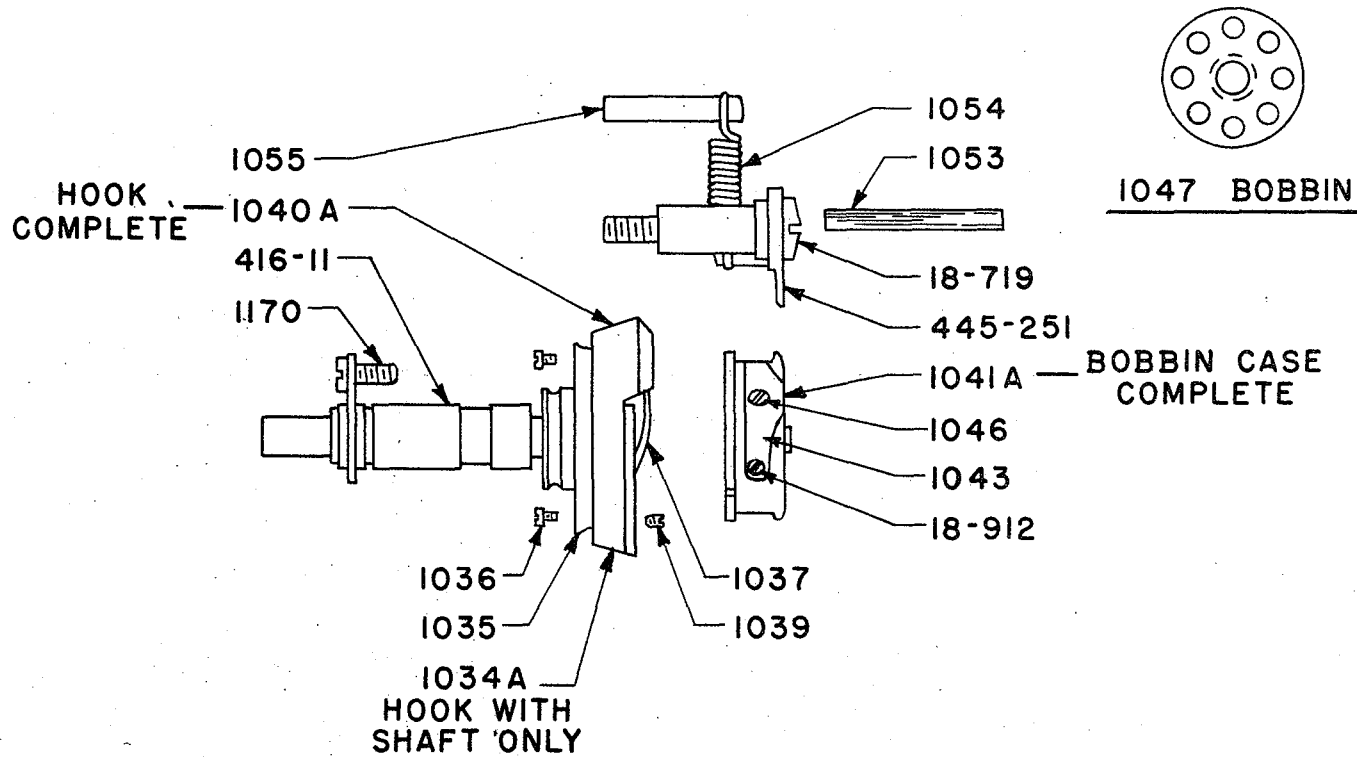

114-154  
102551

PLATE 4

HOOK GROUP  
Models 17-10 and 24-12

✓ 1034A	Hook without Guard or Gib.	1047	Bobbin.
- 1035	Needle and Thread Guard for 1040A.	1053	Stop Pin for 445-251.
✓ 1036	Screw for 1035, (3) used.	1054	Spring for 445-251.
- 1037	Hook Gib.	1055	Spring Pin for 1054.
✓ 1039	Screw for 1037, (2) used.	1170	Clamp Screw for Hook Bushing 416-11.
- 1040A	Hook complete, composed of 1034A, 1035, (3) 1036, 1037 and (2) 1039.	18-719	Bearing Screw for 445-251.
✓ 1041A	Bobbin Case, right hand, complete. Composed of: 18-912, 1043 and 1046 and case.	18-912	Clamp Screw for 1043.
		22-241	Hinge Pin for Bobbin Case latch 51-19. (Not Shown)
✓ 1041C	Latch Spring for 1041A. (Not Shown)	26-148	Bobbin Ejector in 1041A. (Not Shown)
✓ 1043	Tension Spring for 1041A.	51-19	Latch in 1041A. (Not Shown)
✓ 1046	Tension Screw for 1043.	416-11	Adjustable Hook Bushing complete.
		445-251	Bobbin Case Release complete with spring Pin 1049.

# NEEDLE DRIVE GROUP

## MODELS

17-10  
24-12

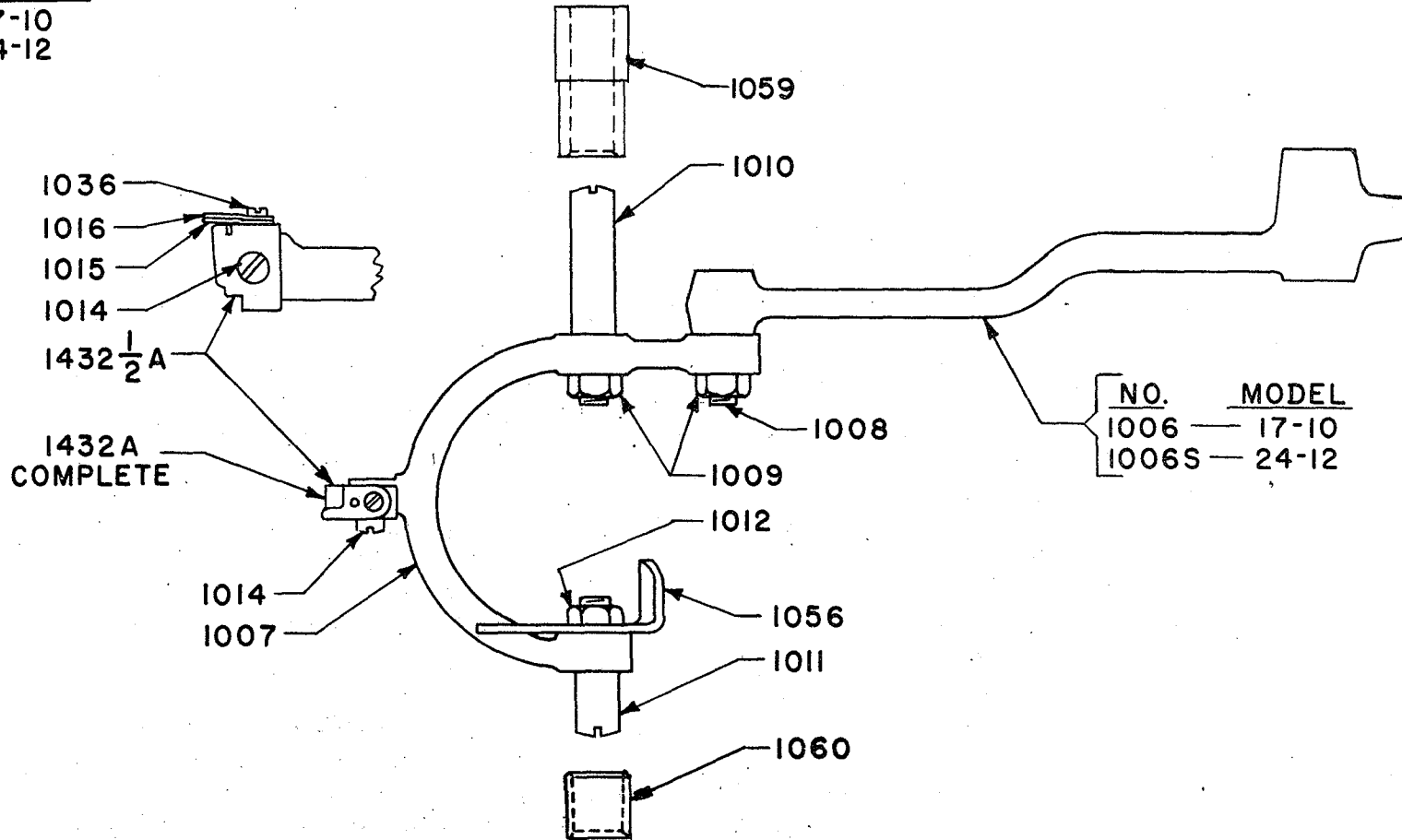

PLATE 5

114-154  
102551

NEEDLE DRIVE GROUP

Models 17-10 and 24-12

1006	Needle Carrier Connecting Link for Model 17-10.
1006S	Needle Carrier Connecting Link for Model 24-12.
1007	Needle Carrier.
1008	Needle Carrier Driving Stud.
1009	Nut for Studs 1008 and 1010.
1010	Needle Carrier Bearing Stud, left.
1011	Needle Carrier Bearing Stud, right.
1012	Nut for 1011.
1014	Clamp Screw for 1432A.
1015	Needle Clamp Thread Guide Plate, lower.
1016	Needle Clamp Thread Guide Plate, upper.
1036	Screw for clamping 1015 and 1016.
1056	Bobbin Case release lever.
1059	Needle Bar Bushing (left hand)
1060	Needle Bar Bushing (right hand)
1432A	Needle Clamp complete, composed of: 1432-1/2A 1015, 1016 and 1036.
1432-1/2A	Needle Clamp with Pin.

# TAKE-UP LEVER GROUP

## MODELS

17-10  
24-12

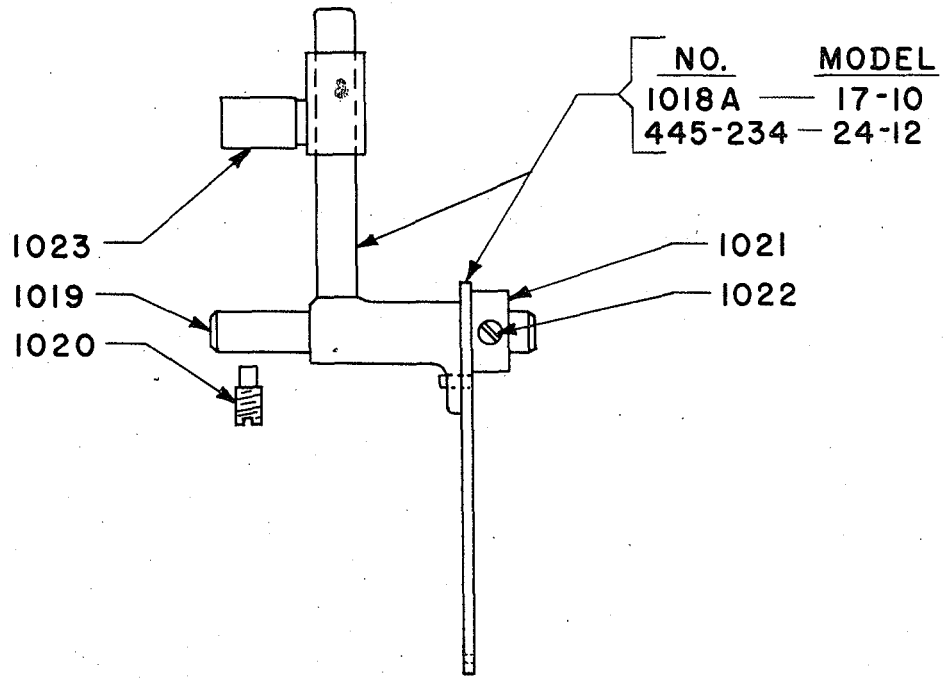

PLATE 6

114-154  
102551



## TAKE-UP LEVER GROUP

Models 17-10 and 24-12

1018A	Take-up Lever complete, for Model 17-10.
1019	Take-up Lever Bearing Shaft.
1020	Set Screw for 1019.
1021	Collar for 1019.
1022	Set Screw for 1021.
1023	Take-up Lever Slide Block.
445-234	Take-up Lever complete, for Model 24-12.

# THREAD TENSION GROUP

## MODELS

17-10

24-12

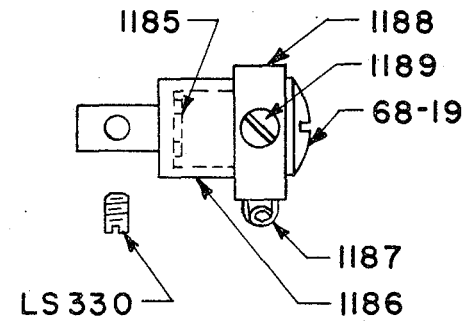
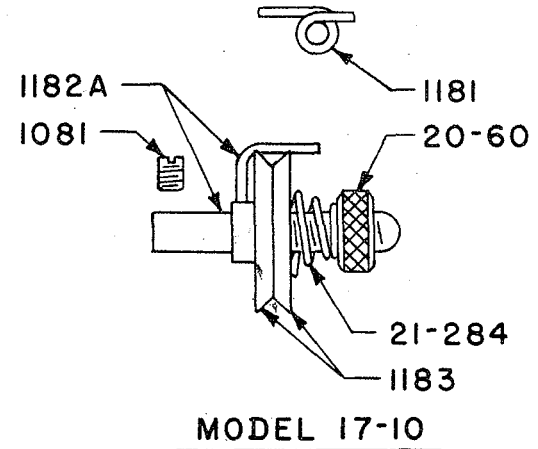
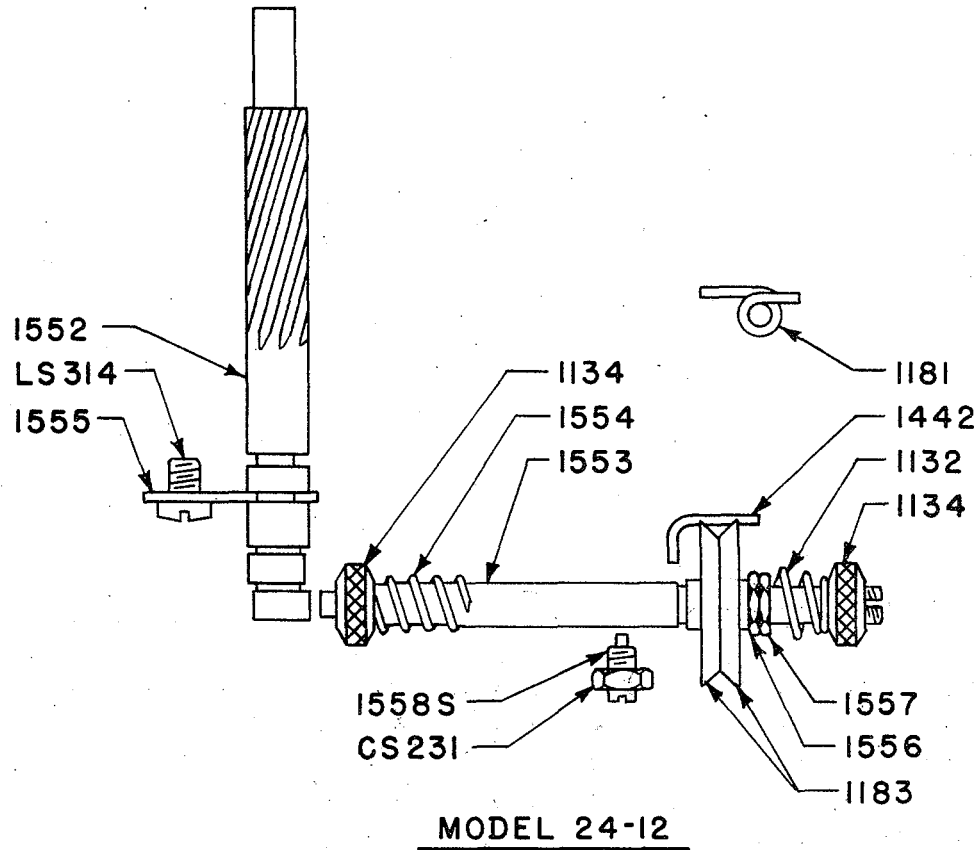

114-154

10255I

PLATE 7

THREAD TENSION GROUP

Models 17-10 and 24-12

CS 231	Nut for Screw 1558S.	1188	Thread controller Staff Stop.
LS 314	Screw for Latch 1555.	1189	Screw for 1188.
LS 330	Set Screw in head for 68-19.	1442	Locating Pin for Disc 1183.
1081	Set Screw in Head for 1182A.	1552	Gear and Cam Shaft, Model 24-12.
1132	Tension Spring Front on 1553, Model 24-12.	1553	Tension Staff, Model 24-12.
1134	Knurled Nut (2) used on 1553 to adjust thread tension, Model 24-12.	1554	Tension Spring rear on 1553, Model 24-12.
1181	Pigtail thread Eyelet.	1555	Latch for 1552, Model 24-12.
1182A	Tension Staff with Pin, Model 17-10.	1556	Adjusting Nut for 1553, Model 24-12.
1183	Tension Disc.	1557	Lock Nut for 1556.
1185	Washer for 68-19	1558S	Pilot Screw for 1553.
1186	Thread controller Staff Barrel.	20-60	Knurled Nut for adjusting tension of thread, Model 17-10.
1187	Thread controller Spring.	21-284	Tension Spring, Model 17-10.
		68-19	Thread controller Staff.

# SKIP STITCH PLUNGER GROUP

## MODELS

17-10  
24-12

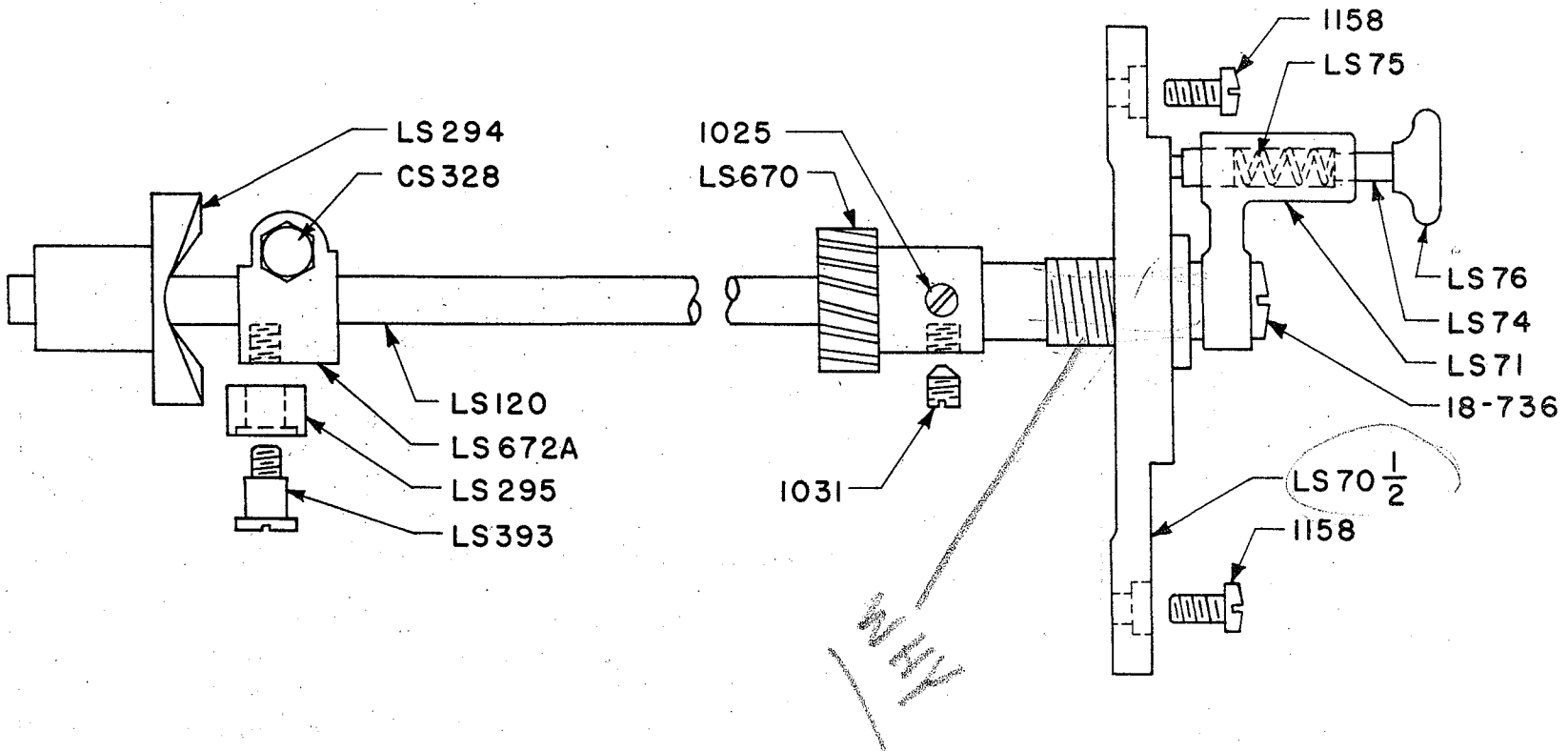

PLATE 8

114-154  
102551

## SKIP STITCH PLUNGER GROUP

Models 17-10 and 24-12

LS 70-1/2	Bearing Block for Vertical Shaft.
LS 71	Skip Stitch Adjusting Crank.
LS 74	Pin for Skip Stitch Crank.
LS 75	Spring for Skip Stitch Crank.
LS 76	Nut for Skip Stitch Adjusting Crank.
LS 120	Vertical Shaft for Plunger Adjuster.
LS 294	Cam for 2-to-1 Skip Stitch.
LS 295	Roll for Skip Stitch Cam.
CS 328	Clamp Screw for LS672.
LS 393	Bearing Screw for Cam Roll LS 295.
LS 670	Spiral Gear on Vertical Shaft LS 120.
LS 672A	Cam Roll Block with Clamp Screw.
1025	Set Screw for Spiral Gear LS 670.
1031	Spot Screw for Spiral Gear LS 670.
1158	Screws (2) used for LS 70-1/2.
18-736	Screw in end of Shaft LS 120, for Crank LS 71.

# COVER GROUP

## MODELS

17-10  
24-12

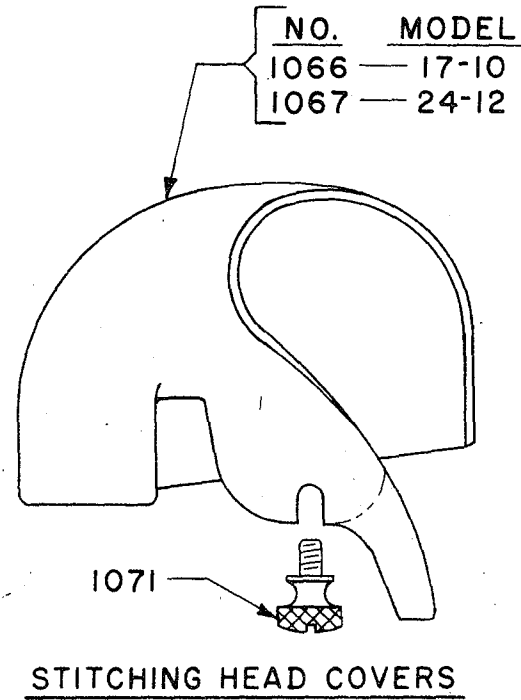
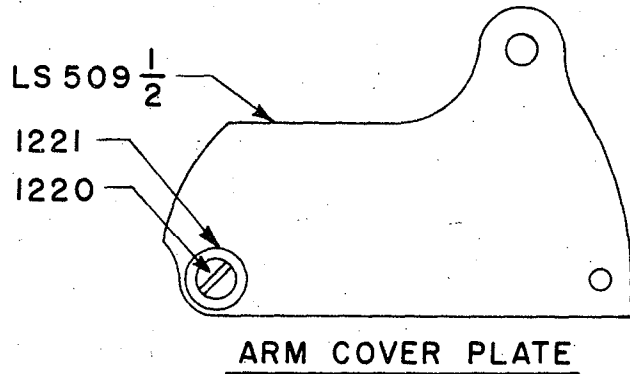
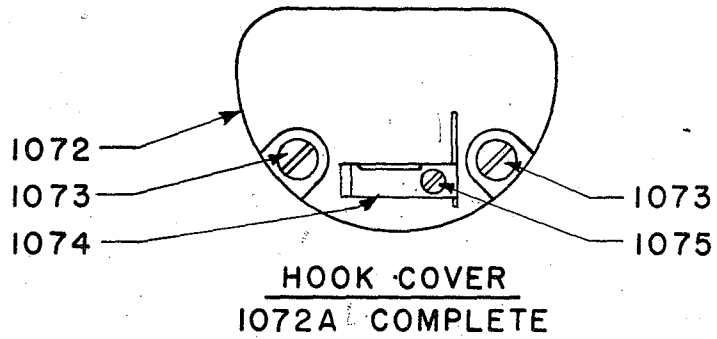

PLATE 9

114-154  
102551

## COVER GROUP

Models 17-10 and 24-12

LS 509-1/2	Cover Plate on top of Arm.
1066	Stitching Head Cover, Model 17-10.
1067	Stitching Head Cover, Model 24-12.
1071	Knurled Screw for stitching Head Cover.
1072	Cover (only), for Hook Gears.
1072A	Cover for Hook Gears, complete, Composed of: 1072, 1074, and 1075.
1073	Screws (2) used for attaching 1072A to Head.
1074	Thread Clip and Cutter.
1075	Screw for 1074.
1220	Screw for LS 509-1/2.
1221	Spring Washer for LS 509-1/2.

# FEED, FEED PLATE AND PLUNGER GROUP

MODEL  
17-10

1263CA  
COMPLETE

1263C

1256

1677A

1671

1254

24-288

1263CA

1671

1262

1261

1260

1160

LS135A

LS317

1249

1160

LS130A

1677A

1368 OS

1414

1415

1671

1669

1673

1672

1273

LS225

1311

1304

LS302

LS165A

FP539

1417A

1413

46-94

1669

1673

1672

LS225

1311

1304

LS302

LS165A

SEE  
PLUNGER  
PLATE 15

1309

LS674

LS23N

LS317

LS395

1251

1303

1160

114-154

102551

PLATE 10



FEED, FEED PLATE & PLUNGER GROUP  
Model 17-10

LS 23N	Feed and plunger bearing block.	1263C	Feed, 3/32 pitch.
LS 130A	Feed elevating shaft with crank complete.	1263CA	Feed complete, composed of 1256, 1261, 1262, 1263C, 1671, 1677A.
LS 135A	Feed rocker shaft with crank.	1303	Bearing stud for 1304.
LS 165A	Plunger elevating shaft with crank.	1304	Plunger frame link.
LS 225	Guide pin in 1273 for feed spring LS 405.	1309	Plunger barrel spring, heavy.
LS 302	Bearing screw for 1304.	1311	Nut for plungers (2) used.
LS 317	Clamp screws for LS 23N.	1368OS	Plunger equalizing spring.
LS 395	Screw for clamping work plate LS 22, Model 17-10.	1413	Feed plate stem.
FP 539	Clamp screw for Feed Plate Yoke 1415.	1414	Screws for feed plate 24-288.
LS 674	Plunger Frame.	1415	Feed Plate Yoke.
1160	Nut for bearing screws LS 302, 1249, 1260 and 1303.	1417A	Feed plate yoke complete, composed of: 1413, 1415 and FP 539.
1249	Bearing stud in LS 130A for link 46-94.	1669	Feed elevating bell crank.
1251	Bearing screw in 1669 for link 46-94.	1671	Bearing screw for 1677A (2) used.
1254	Spring pin for 1256.	1672	Roll on Screw 1673 for 1273.
1256	Feed retaining spring.	1673	Bearing screw for roll 1672.
1260	Bearing screw for 1261.	1677A	Feed elevating link with pin 1254.
1261	Feed link.	24-288	Feed Plate.
1262	Hinge pin for 1261.	46-94	Feed elevating link.

# FEED, FEED PLATE AND PLUNGER GROUP

MODEL  
24-12

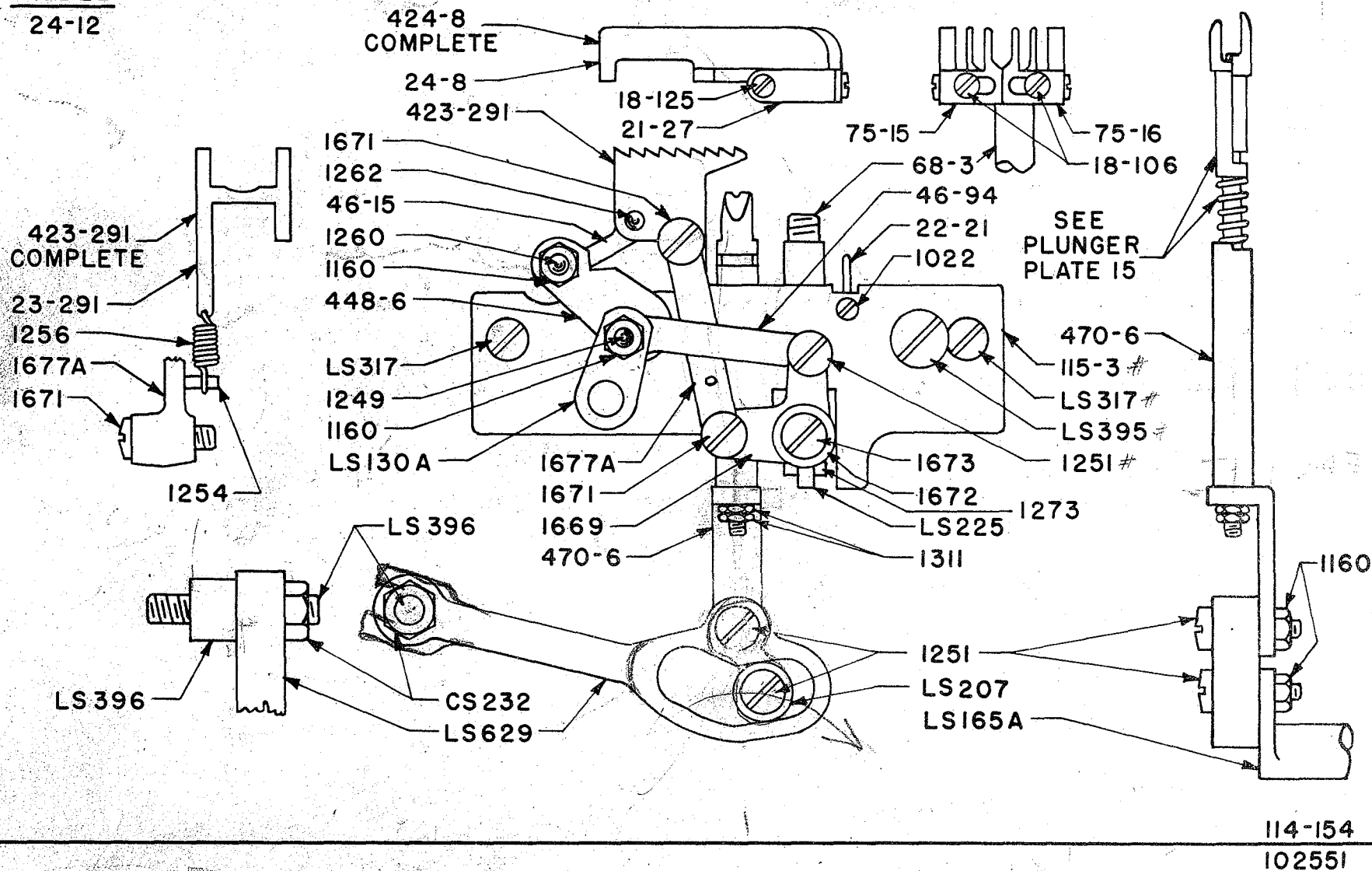

PLATE 11

## FEED, FEED PLATE &amp; PLUNGER GROUP

Model 24-12

LS 130A	Feed elevating shaft <u>with</u> crank complete.	1673	Bearing screw for roll 1672.
LS 165A	Plunger Elevating Shaft with crank.	1677A	Feed elevating link with pin 1254.
LS 207	Roll for cam slot in LS 629.	18-106	Screws for feed plate guides 75-15 and 75-16.
LS 225	Guide Pin in 1273 for feed spring LS 405.	18-125	Screws for springs 21-27.
CS 232	Nut for stud LS 396.	21-27	Springs for feed plate guides 75-15 and 75-16.
LS 317	Clamp screws for block 115-3.	22-21	Pin for separating feed plate guides.
LS 395	Screw for clamping work plate 4-129.	23-291	Feed 1/8" pitch.
LS 396	Stud for LS 629.	24-8	Feed plate.
LS 629	Plunger elevating cam.	46-15	Feed Link.
1022	Screw for 22-21.	46-94	Feed elevating Link.
1160	Nut for 1249, 1251 and 1260.	68-3	Staff for feed plate.
1249	Bearing Stud in LS 130A for link 46-94.	75-15	Guide (left) for feed plate.
1251	Bearing screw in 1669 for link 46-94.	75-16	Guide (right) for feed plate.
	Bearing screw in LS 629 for 470-6 and Roll LS 207.	115-3	Feed and plunger bearing block.
		423-291	Feed complete, composed of: 23-291, 46-15, 1256, 1262, 1671 and 1677A.
1254	Spring pin for 1256.		Feed plate complete, composed of: (2) 18-106, (2) 18-125, (4) 2-127, 24-8, 68-3, 75-15 and 75-16.
1256	Feed Retaining Spring		Crank with shaft and pin for rocking feed.
1260	Bearing screw for 46-15.	424-8	Plunger sleeve complete.
1262	Hinge pin for 46-15.		
1273	Feed Spring Slide Block.		
1311	Nut for Plunger (2) used.	448-6	
1669	Feed elevating bell crank.		
1671	Bearing Screw for 1677A (2) used.	470-6	
1672	Roll on Screw 1673 for 1273.		

FEED ELEVATING GROUP

# FEED ELEVATING GROUP

**MODELS**

17-10  
24-12

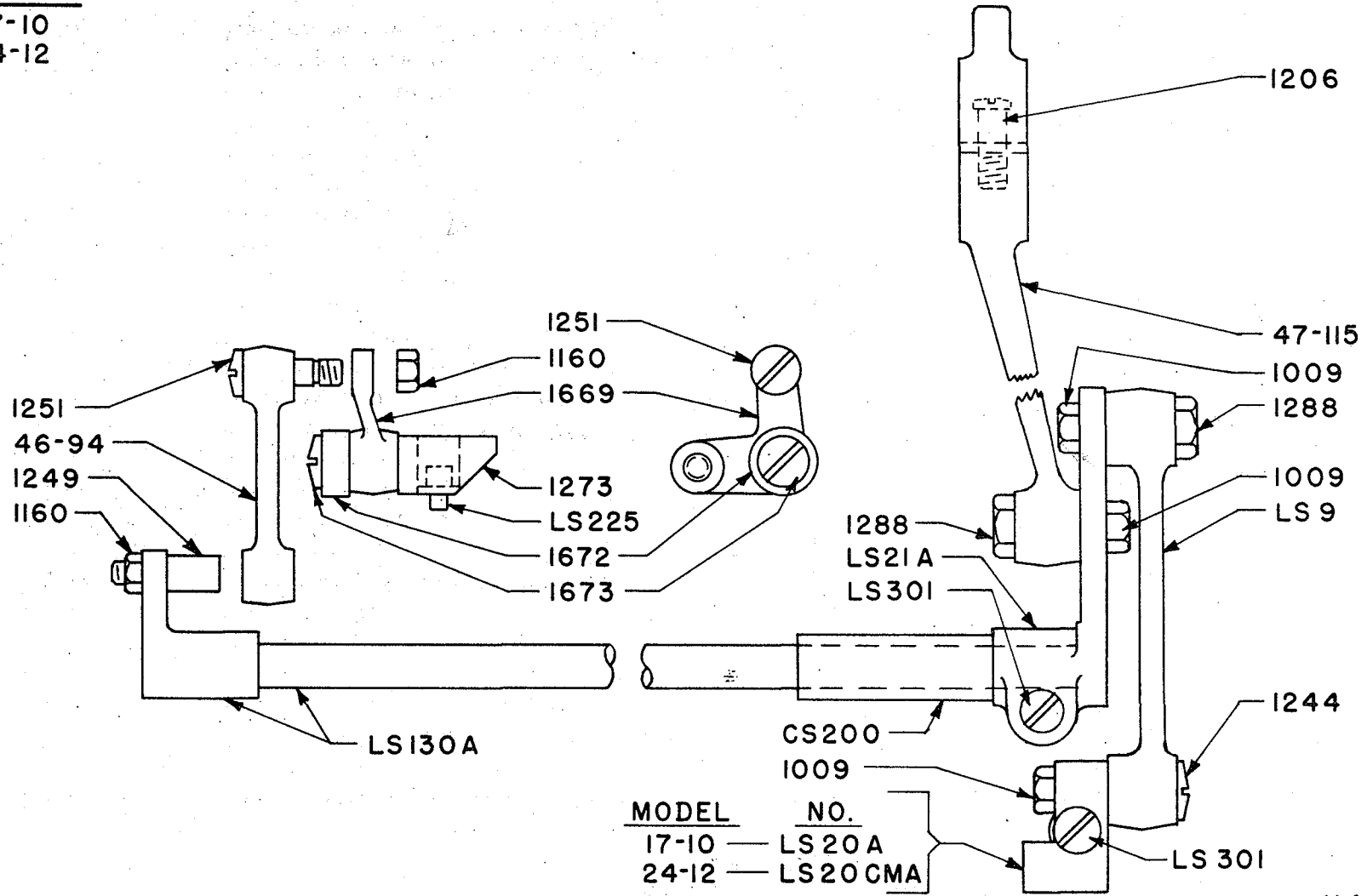

PLATE 12

114-154  
102551

## FEED ELEVATING GROUP

- LS 9 Plunger Differential Link.
- LS 20A Plunger Elevating Crank with Screw LS 301. Model 17-10

## FEED ELEVATING GROUP

LS 9	Plunger Differential Link.
LS 20A	Plunger Elevating Crank with Screw LS 301, Model 17-10.
LS 20CMA	Plunger Elevating Crank with Screw LS 301, Model 24-12.
LS 21A	Feed Elevating Crank with Screw LS 301.
LS 130A	Feed Elevating Shaft with Crank complete.
CS 200	Bushing for LS 130A
LS 225	Guide Pin in 1273 for Feed Spring LS 405.
LS 301	Clamp Screw for LS 20A, LS 20CMA and LS 21A.
1009	Nut for Bearing Screws 1244 and 1288.
1160	Nut for Bearing Screws 1251 and 1249.
1206	Clamp Screw for connecting Rod 47-115.
1244	Bearing Screw for LS 9.
1249	Bearing Stud in LS 130A.
1251	Bearing Screw for 46-94.
1273	Feed Spring Slide Block.
1288	Bearing Screw for 47-115 and LS 9.
1669	Feed elevating Bell Crank.
1672	Roll on Screw 1673 for 1273.
1673	Bearing Screw for roll 1672.
46-94	Feed Elevating Link.
47-115	Feed Elevating Connecting Rod.

30-18  
13-10  
WODETE

FEED ELEVATING GROUP

# FEED DRIVING GROUP

MODELS  
 17-10  
 24-12

NO.	MODEL
1261	17-10
46-15	24-12

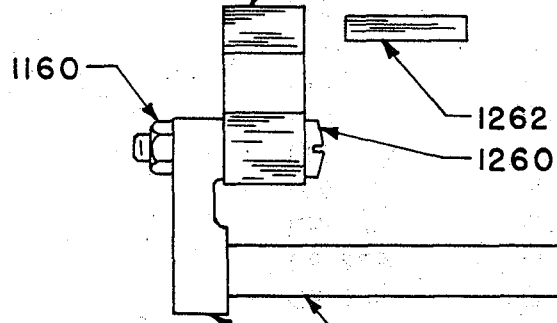

NO.	MODEL
LS135A	17-10
448-6	24-12

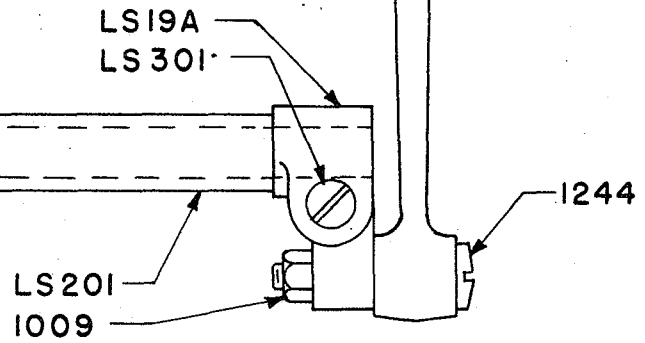

114-154  
 102551

PLATE 13

## FEED DRIVING GROUP

LS 19A	Feed Rocker Crank with Screw LS 301.
LS 135A	Feed Rocker Shaft with Crank, Model 17-10.
LS 201	Bushing in Base for LS 135A and 448-6.
LS 301	Clamp Screw for LS 19A.
1009	Nut for Bearing Screw 1244.
1160	Nut for Bearing Screw 1260.
1205	Feed Rocker Connecting Rod.
1206	Clamp Screw for 1205.
1244	Bearing Screw for 1205.
1260	Bearing Screw for 1261 and 46-15.
1261	Feed Link, Model 17-10.
1262	Hinge Pin for 1261.
46-15	Feed Link, Model 24-12.
448-6	Crank with Shaft and Pin for rocking feed, Model 24-12.

# PLUNGER CRADLE AND ADJUSTING GROUP

## MODELS

17-10  
24-12

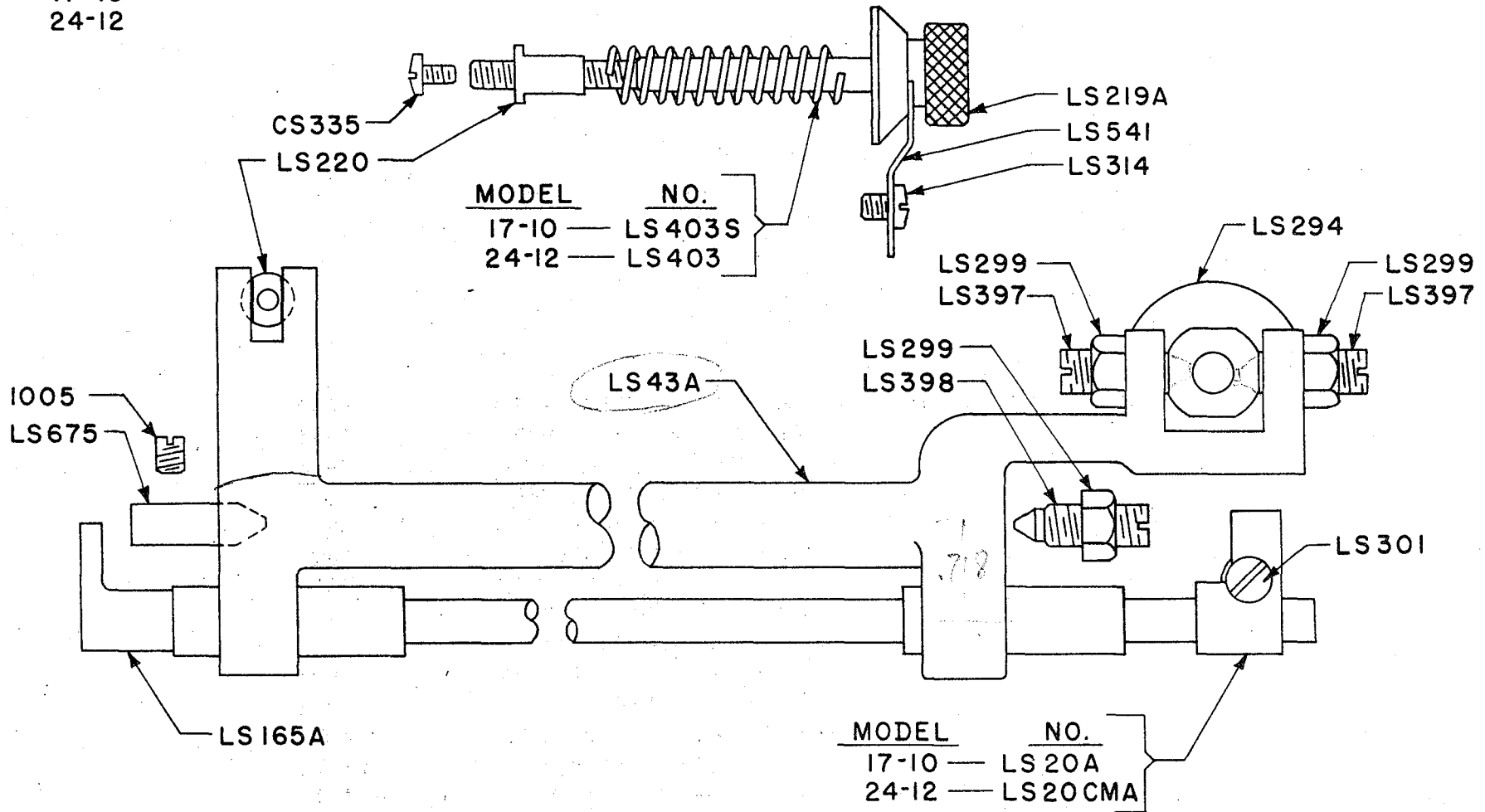

PLATE 14

114-154  
102551



PLUNGER CRADLE AND ADJUSTING GROUP

LS 20A Plunger Elevating crank with screw LS 301, Model 17-10.  
LS 20CMA Plunger Elevating crank with screw LS 301, Model 24-12.  
LS 43A Plunger cradle complete with bushings.  
LS 165A Plunger elevating shaft with crank.  
LS 219A Plunger adjuster knob complete with shaft and pin.  
LS 220 Nut for LS 219A.  
LS 294 Cam for producing 2-to-1 skip stitch.  
LS 299 Lock Nut for pivot screws LS 397 and LS 398.  
LS 301 Clamp Screw for LS 20A and LS 20CMA.  
LS 314 Clamp screw for LS 541.  
CS 335 Screw for LS 219A.  
LS 397 Pivot screw for LS 294 (2) used.  
LS 398 Pivot screw for cradle LS 43A,  
LS 403 Plunger adjuster spring, Model 24-12.  
LS 403S Plunger adjuster spring, Model 17-10.  
LS 541 Plunger adjuster retaining spring.  
LS 675 Bearing center for LS 43A.  
1005 Set Screw for LS 675.

# PLUNGER GROUP

## MODELS

17-10  
24-12

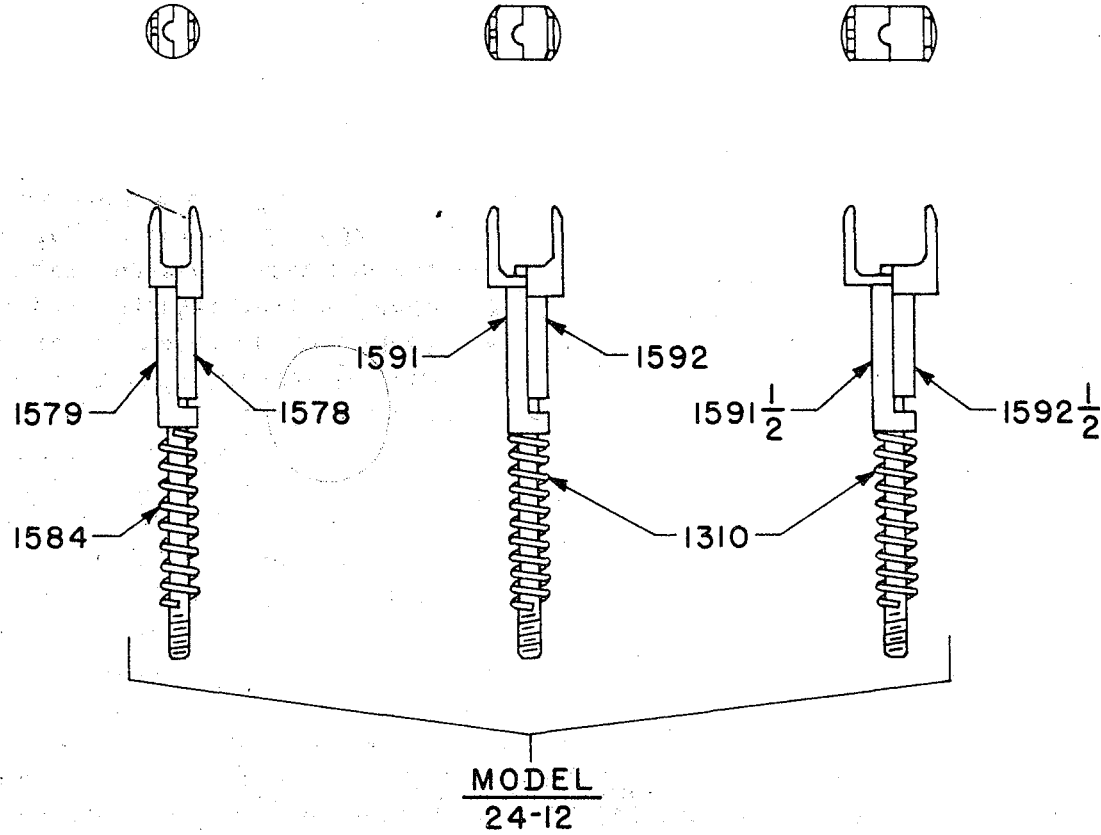
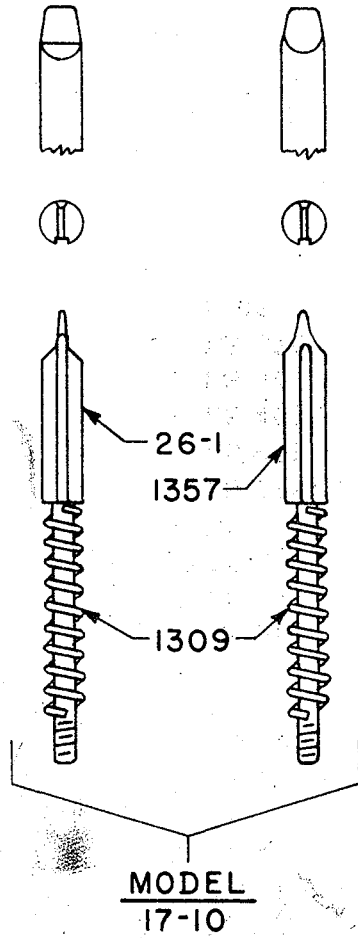

114-154  
102551

PLATE 15

## PLUNGER GROUP

1309	Plunger barrel spring, heavy.
1310	Plunger barrel spring, light.
1357	Plunger sharp edge, use with feet 1343A, 1343SA, 1373A, 1373SA, Model 17-10.
1578	Plunger (long) use with Foot 1571A, light, Model 24-12.
1579	Plunger (short) use with Foot 1571A, light. Model 24-12.
1584	Plunger spring, use with 1578 and 1579.
1591	Plunger (short) use with Foot 1593A, Medium. Model 24-12.
1591-1/2	Plunger (short) use with Foot 1593SA, heavy. Model 24-12.
1592	Plunger (long) use with Foot 1593A, medium. Model 24-12.
1592-1/2	Plunger (long) use with Foot 1593SA, heavy. Model 24-12.
26-1	Plunger for light material, Model 17-10.

# KNEE PRESS GROUP

## MODELS

17-10  
24-12

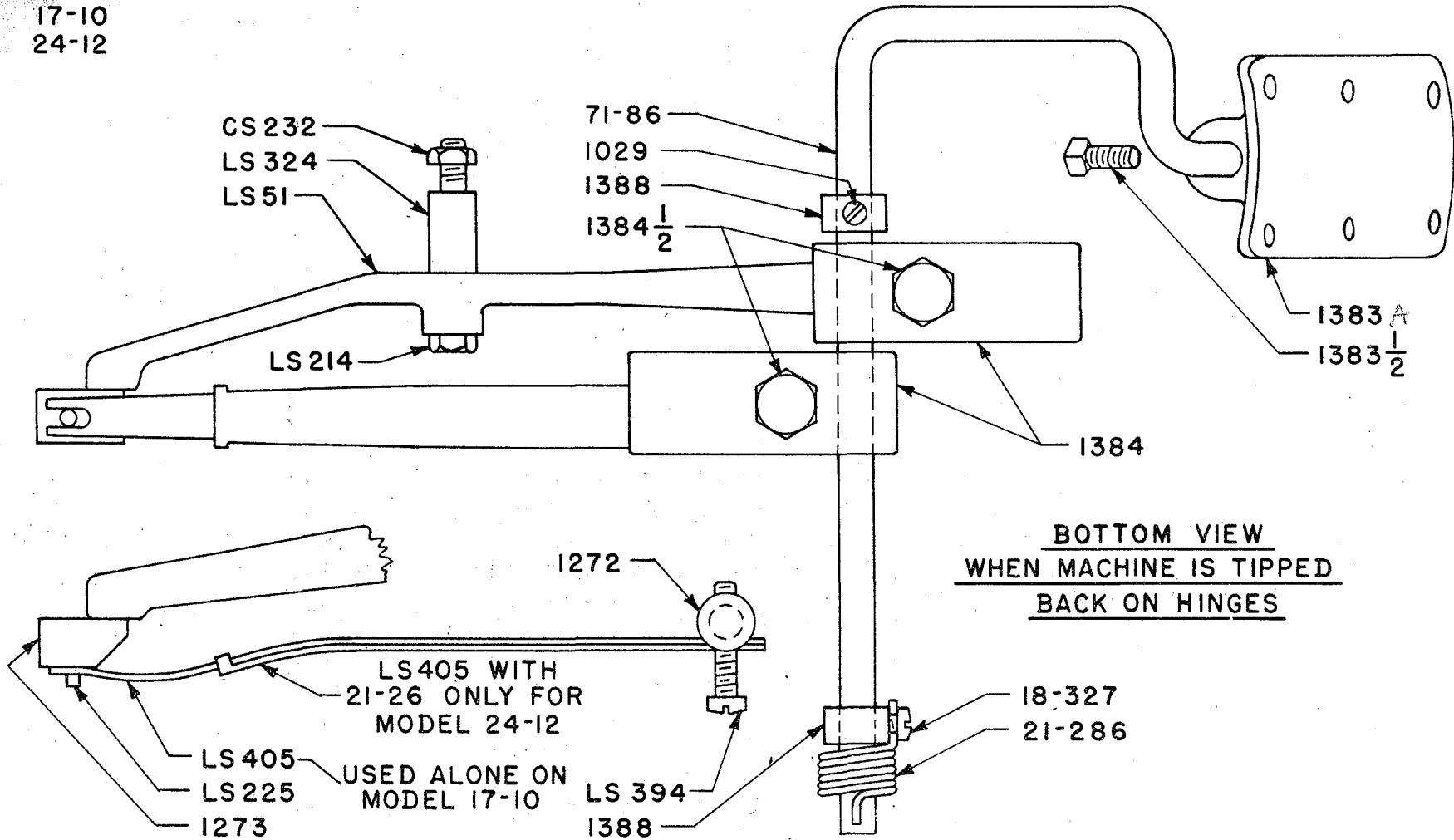

BOTTOM VIEW  
WHEN MACHINE IS TIPPED  
BACK ON HINGES

PLATE 16

114-154  
102551

## KNEE PRESS GROUP

LS 51	Feed depresser lever.
LS 214	Lock nut for LS 324.
LS 225	Guide pin in 1273 for spring LS 405.
CS 232	Nut on LS 324.
LS 324	Stud for LS 51.
LS 394	Screw for LS 405.
LS 405	Long feed spring for Model 17-10 and 24-12.
1029	Set Screw for Collar 1388.
1272	Nut for feed springs LS 405 and 21-26.
1273	Feed spring slide block.
1383A	Knee press pad. with screw 1383 1/2.
1383-1/2	Set screw for 1383A,
1384	Elevating levers (2) used.
1384-1/2	Clamp screws for 1384.
1388	Collar for 71-86.
	Collar for 21-286.
18-327	Screw for 1388 and spring 21-286.
21-26	Short feed spring for Model 24-12.
21-286	Spring on 71-86 for 1383.
71-86	Knee lift rod.

# WORK-SUPPORT PLATE GROUP

## MODELS

17-10  
24-12

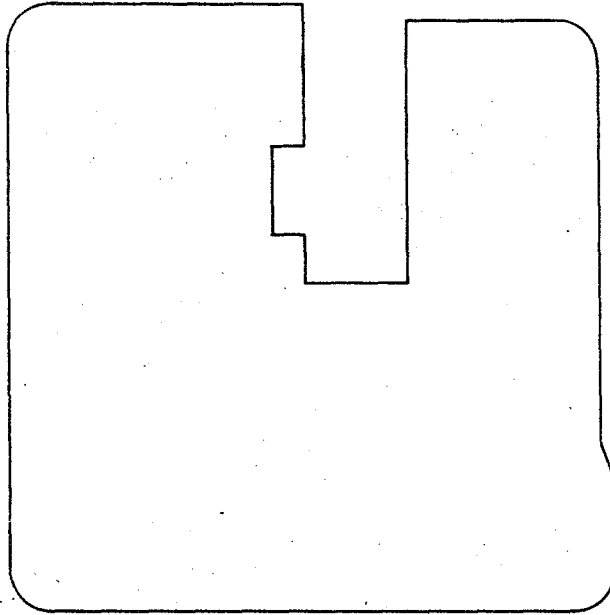
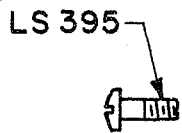

LS 22  
for  
MODEL 17-10

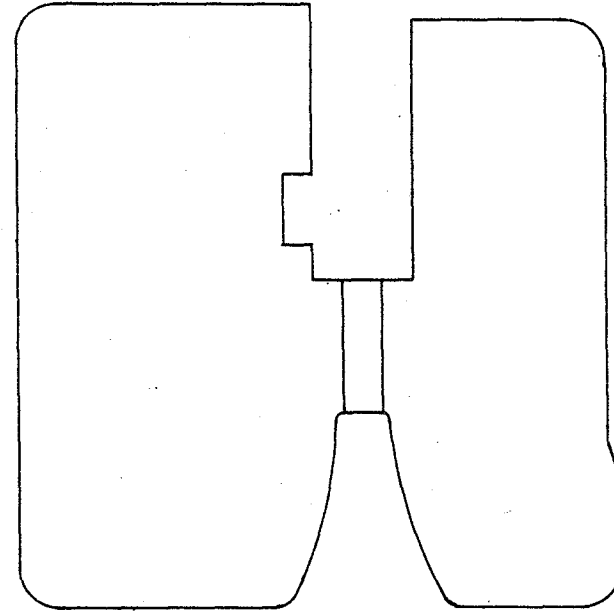
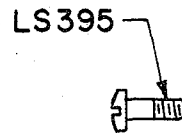

4-129  
for  
MODEL 24-12

114-154  
102551

## WORK SUPPORT PLATE GROUP

Model 17-10 and 24-12

LS 22	Work Support Plate, Model 17-10.
LS 395	Clamp screw for LS 22.
	Clamp screw for 4-129.
4-129	Work support plate, Model 24-12.

# MISCELLANEOUS

## MODELS

17-10  
24-12

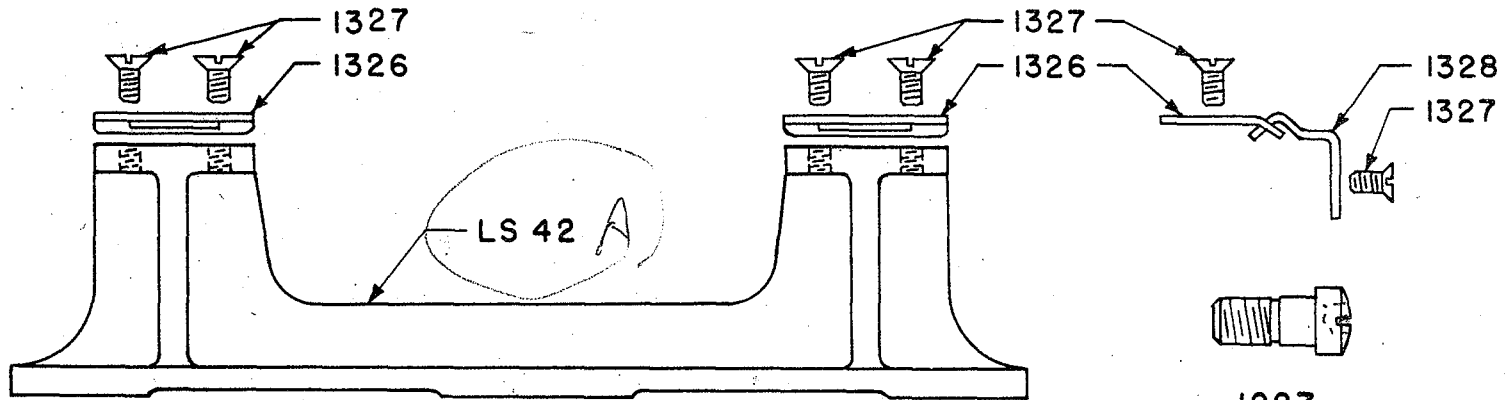

1227

(8-104)

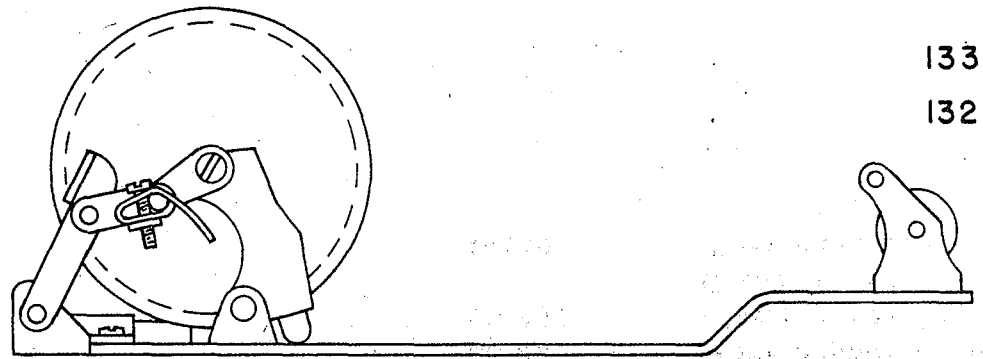

4145-6

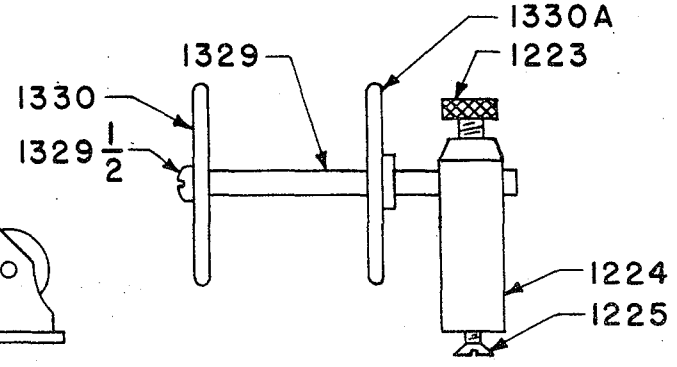

1222 A COMPLETE

PLATE 18

114-154

3652 102551

REPRODUCTION OF ORIGINAL DRAWING



MISCELLANEOUS GROUP

Model 17-10 and 24-12

LS 42 Bracket for machine hinge.  
1222A Spool holder complete. Composed of: 1223,  
1224, 1225, 1329, 1329-1/2, 1330 and 1330A.  
1223 Screw for Spool Holder 1222A.  
1224 Post for 1222A.  
1225 Screw for 1224 Post.  
1227-18-1045 Head cap screws and arm and base screws.  
1326 Hinge on bracket LS 42 (2) used.  
1327 Screws for hinges, (8) used.  
1328 Hinge on base, (2) used.  
1329 Shaft for 1222A.  
1329-1/2 Screw for 1330 on 1222A.  
1330 Spool Holder Disc Front, for 1222A.  
1330A Spool Holder Disc with hub for 1222A.  
4145-6 Bobbin winder complete.

# PRESSER FOOT GROUP

MODELS  
24-12

1571A FOR LIGHT MATERIAL  
1593A FOR MEDIUM TO HEAVY MATERIAL  
1593SA FOR EXTRA HEAVY MATERIAL

*Correct Detail on 1598 1/4*

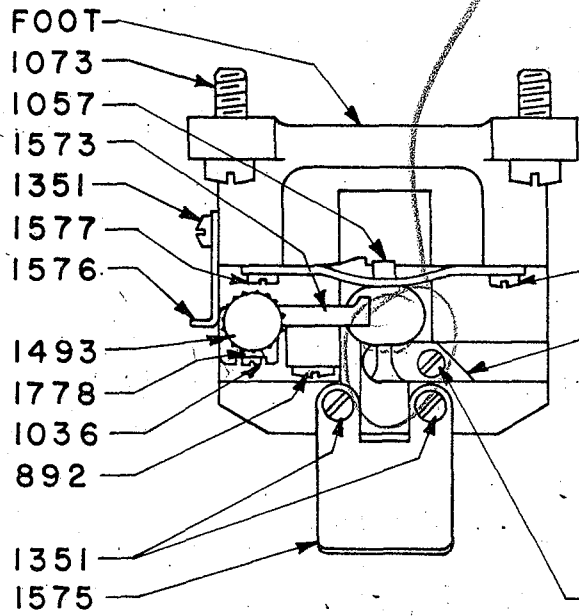

1571A  
FOOT COMPLETE

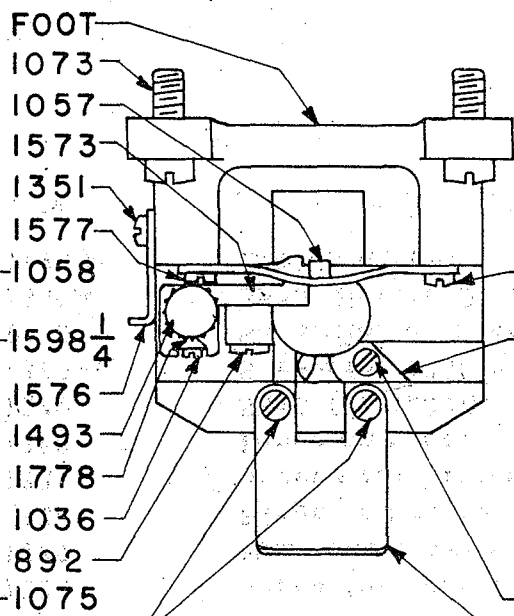

1593A  
FOOT COMPLETE

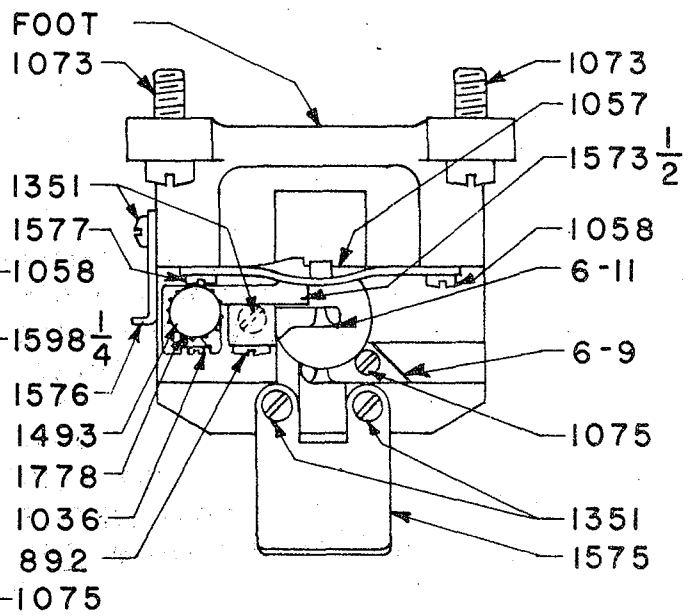

1593SA  
FOOT COMPLETE

PLATE 19

114-154  
102551

## PRESSER FOOT GROUP

Model 24-12

892	Bearing screw for crowns 1573 and 1573-1/2.
1036	Screw for retaining spring 1778.
1057	Bobbin case retainer.
1058	Screw for bobbin case retainer 1057 (Right side).
1073	Clamp screws for presser foot.
1075	Clamp screw for needle guides 1598-1/4 and 6-9.
1351	Clamp screws for needle guard 1575 (2) used. Clamp screw for edge guide 1576. Clamp screw for 6-11.
1493	Adjusting screw for crown.
1571A	Presser Foot for light work, complete. Composed of 892, 1036, 1057, 1058, 1075, (3) 1351, 1493, Foot, 1573, 1575, 1576, 1577, 1598-1/4 and 1778.
1573	Crown for 1571A and 1593A. 8724
1573-1/2	Crown for 1593SA.
1575	Needle guard for 1571A, 1593A and 1593SA.
1576	Edge guide for feet 1571A, 1593A and 1593SA.
1577	Screw for bobbin case retainer 1057 (Left side).
1593A	Presser Foot for medium to heavy work, complete, composed of 892, 1036, 1057, 1058, 1075, (3) 1351, 1493, 1573, 1575, 1576, 1577, Foot, 1598-1/4, and 1778.
1593SA	Presser Foot for extra heavy work, complete. Composed of 6-9, 6-11, 892, 1036, 1057, 1058, 1075, (4) 1351, 1493, 1573-1/2, 1575, 1576, 1577, Foot, and 1778
1598-1/4	Needle guide for 1571A and 1593A. 10756
1778	Retaining spring for crown screw 1493. 1036
6-9	Needle guide for 1593SA.
6-11	Needle guide (center) for 1593SA.

# PRESSER FOOT GROUP

MODELS  
17-10

1343A FOR TURNED UNDER EDGES  
1343SA FOR LIGHT & MEDIUM MATERIAL  
1373A FOR MEDIUM MATERIAL  
1373SA FOR EXTRA HEAVY MATERIAL

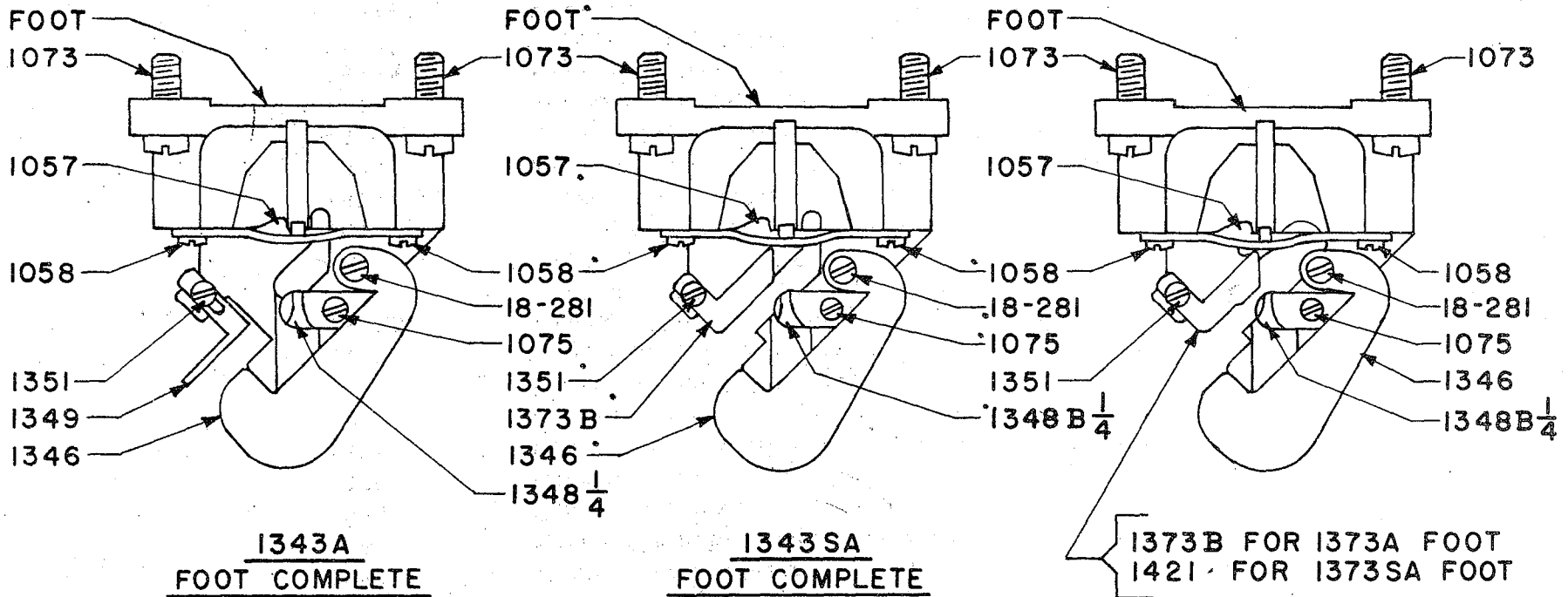

PLATE 20

114-154  
102551

PRESSER FOOT GROUP

Model 17-10

1057 Bobbin case retainer.  
1058 Clamp screws for 1057.  
1073 Clamp screws for presser foot.  
1075 Screw for needle guides 1348-1/4 and 1348B-1/4.  
1343A Presser foot complete. Composed of 18-281, 1057, (2) 1058, 1075,  
Foot, 1346, 1348-1/4, 1349 and 1351.  
1343SA Presser foot for light and medium work, complete. Composed of:  
18-281, 1057, (2) 1058, 1075, Foot, 1346, 1348B-1/4, 1351 and 1373B.  
1346 Needle Guard.  
1348-1/4 Needle guide for foot 1343A.  
1348B-1/4 Needle guide for feet 1343SA, 1373A and 1373SA.  
1349 Edge guide for foot 1343A.  
1351 Screw for edge guides.  
1373A Presser foot for medium work, complete. Composed of: 18-281, 1057,  
(2) 1058, 1075, 1346, 1348B-1/4, 1351, Foot and 1373B.  
1373B Edge guide for 1343SA and 1373A.  
1373SA Presser foot for extra heavy work, complete. Composed of: 18-281,  
1057, (2) 1058, 1075, 1346, 1348B-1/4, 1351, Foot, 1421.  
1421 Edge guide for 1373SA.  
18-281 Clamp screw for needle guard 1346.

# PRESSER FOOT GROUP

MODELS  
17-10

405-1 FOR LIGHT & MEDIUM MATERIAL  
405-2 FOR EXTRA HEAVY MATERIAL  
405-3 FOR MEDIUM & MEDIUM-HEAVY MATERIAL

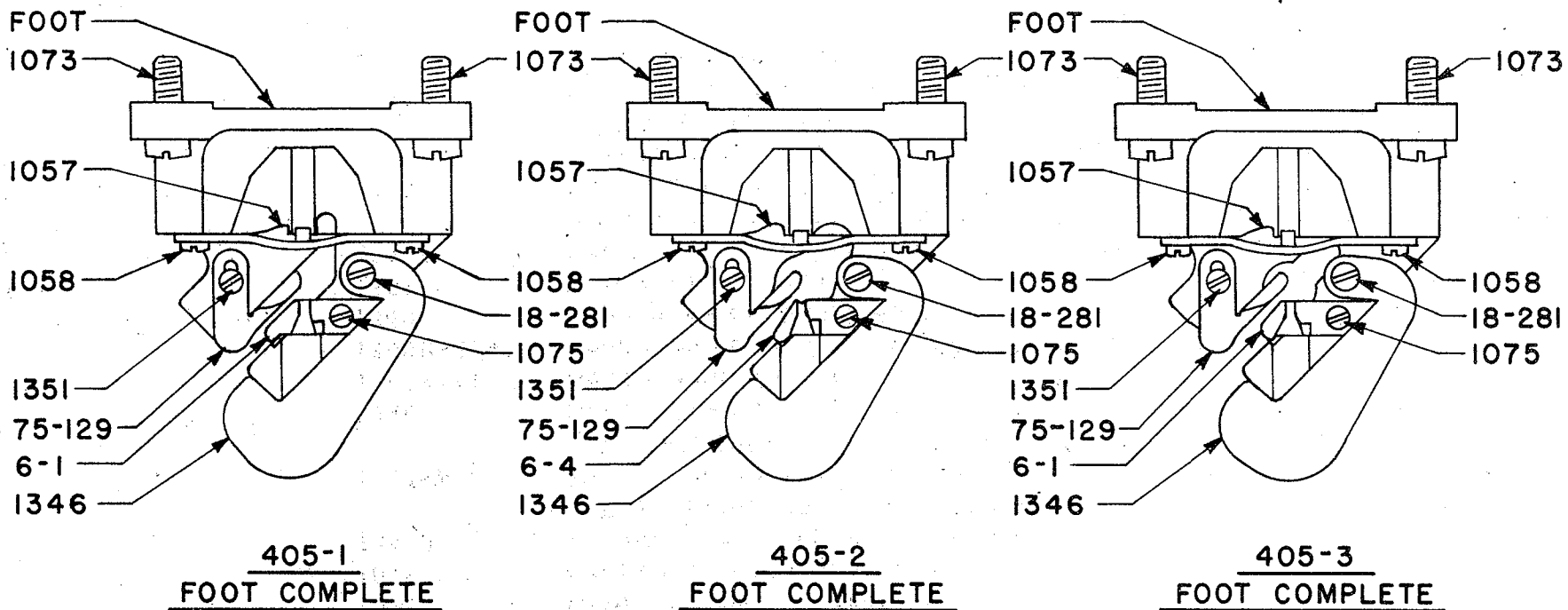

PLATE 21

114-154  
102551

## PRESSER FOOT GROUP

### For Piped Edges

- 1057 Bobbin case retainer.
- 1058 Screws for 1057.
- 1073 Clamp screws for presser feet.
- 1075 Clamp screw for needle guide.
- 1346 Needle guard.
- 1351 Clamp screw for plow edge guide 75-129.
- 6-1 Plow edge and needle guide for feet 405-1 and 405-3.
- 6-4 Plow edge and needle guide for foot 405-2.
- 18-281 Clamp screw for needle guard 1346.
- 75-129 Edge guide for feet, 405-1, 405-2 and 405-3.
- 405-1 Presser foot complete for felling piped edges on light and medium work.  
Composed of: Foot, 6-1, 18-281, 75-129, 1057, (2) 1058, 1075, 1346  
and 1351. Use with standard plunger 1357.
- 405-2 Presser foot complete for felling piped edges on extra heavy work.  
Composed of: Foot, 6-4, 18-281, 75-129, 1057, (2) 1058, 1075, 1346  
and 1351. Use with standard plunger 1357.
- 405-3 Presser foot complete for felling piped edges on medium and heavy work.  
Composed of: Foot, 6-1, 18-281, 75-129, 1057, (2) 1058, 1075, 1346  
and 1351. Use with standard plunger 1357.

# PRESSER FOOT GROUP

MODELS  
17-10

- 405-5 FOR SILK & RAYON MATERIAL
- 405-34 EXTRA LIGHT FOR SILK & RAYON
- 405-131 FOR KNIT GOODS

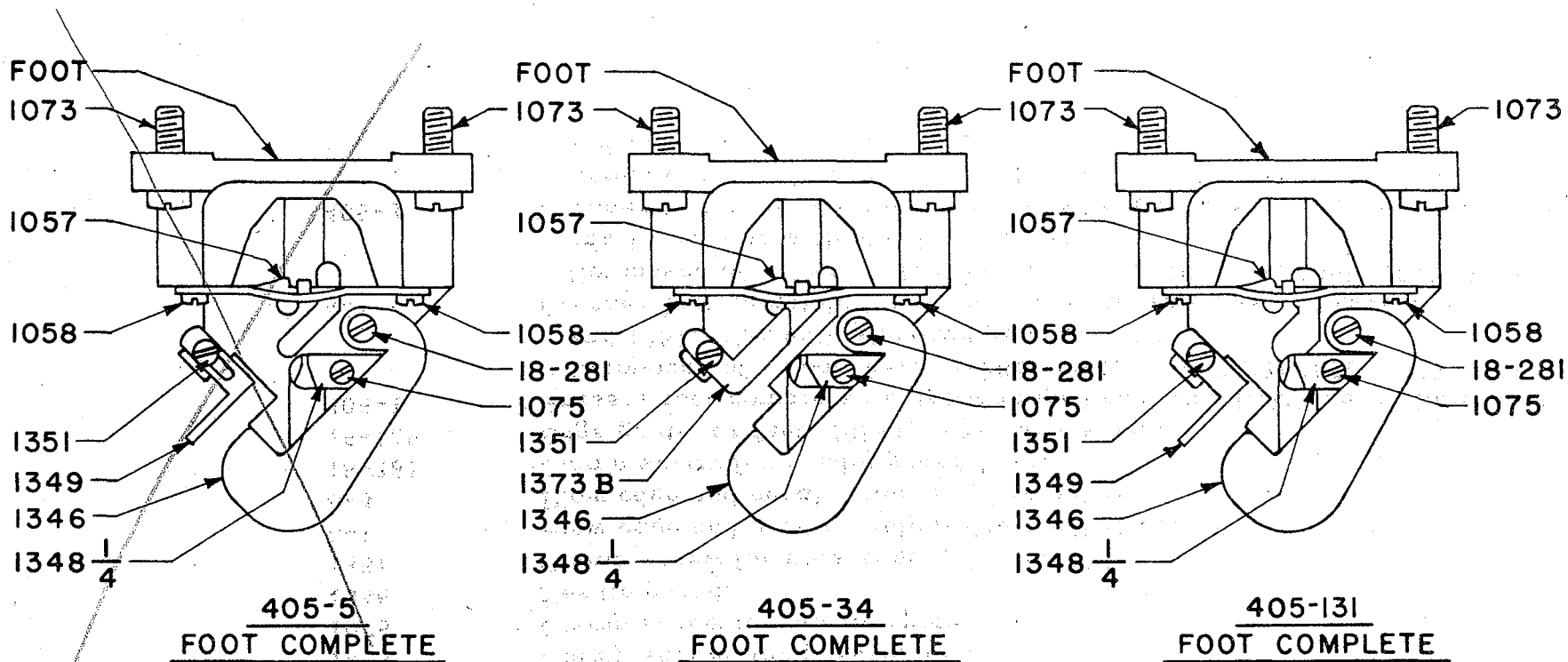

PLATE 22

*obsolete -  
cannot supply.*

114-154  
102551



**PRESSER FOOT GROUP**  
For  
Silks, Rayons and Knit Materials  
Model 17-10

- |          |  |
|----------|--|
| 1057     | Bobbin case retainer.  |
| 1058     | Screws for 1057.   |
| 1073     | Clamp screws for Presser feet.   |
| 1075     | Clamp screw for needle guide.  |
| 1346     | Needle guard.  |
| 1348-1/4 | Needle Guide.  |
| 1349     | Edge guide for foot 405-5 and 405-131.   |
| 1351     | Screw for edge guides.   |
| 1373B    | Edge guide for foot 405-34.  |
| 18-281   | Clamp screw for needle guard 1346.   |
| 405-5    | Presser foot complete, for silks and rayons, 1/8" cloth opening.<br>Composed of: Foot, 18-281, 1057, (2) 1058, 1075, 1346, 1348-1/4,<br>1349 and 1351. Use with plunger 26-1.              |
| 405-34   | Presser foot complete, extra light for silks and rayons. 1/8" cloth<br>opening. Composed of: Foot, 18-281, 1057, (2) 1058, 1075, 1346,<br>1348-1/4, 1351 and 1373B. Use with plunger 26-1. |
| 405-131  | Presser foot complete for knit materials. Composed of: Foot,<br>18-281, 1057, (2) 1058, 1075, 1346, 1348-1/4, 1349 and 1351. Use<br>with standard plunger 1357.                            |

## NUMERICAL INDEX

PLATES ARE FROM PAGE 28 TO 70

PART NO.	PLATE NOS.	PART NO.	PLATE NOS.
✓ LS 6	1	✓ LS 324	16
✓ LS 7A	1	✓ CS 328	8
✓ LS 9	12	✓ LS 330	7
• <del>LS 12</del> 16-353	1	✓ CS 335	14
✓ LS 19A	13	✓ CS 337	2
✓ LS 20A	12, 14	✓ LS 393	8
✓ LS 20CMA	12, 14	✓ LS 394	16
✓ LS 21A	12	✓ LS 395	10, 11, 17
✓ LS 22	17	✓ LS 396	11
✓ LS 23N	10	✓ LS 397	14
✓ LS 42	18	✓ LS 398	14
✓ LS 43A	14	✓ LS 403	14
✓ LS 51	16	✓ LS 403S	14
✓ LS 70-1/2	8	✓ LS 405	16
✓ LS 71	8	• <del>LS 509-1/2</del> 32-287	9
✓ LS 74	8	✓ CS 510	2
✓ LS 75	8	✓ FP 539	10
✓ LS 76	8	✓ LS 541	14
✓ LS 120	8	✓ LS 629	11
✓ LS 130A	10, 11, 12	✓ LS 670	8
✓ LS 135A	10, 13	✓ LS 671	1
✓ LS 165A	10, 11, 14	✓ LS 672A	8
✓ CS 200	12	✓ LS 674	10
✓ LS 201	13	✓ LS 675	14
✓ LS 207	11	892	19
✓ LS 210	1	1001	2
✓ LS 214	16	1002	2
✓ LS 219A	14	1002-1/2	2
✓ LS 220	14	1003	2
✓ LS 225	10, 11, 12, 16	1004	2
✓ CS 231	7	1005	1, 2, 14
✓ CS 232	11, 16	1006	5
✓ LS 294	8, 14	1006S	5
✓ LS 295	8	1007	5
✓ LS 299	14	1008	5
✓ LS 301	12, 13, 14	1009	5, 12, 13
✓ LS 302	10	1010	5
✓ LS 314	7, 14	1011	5
✓ LS 317	10, 11	1012	5
• <del>CS 320-1/2</del> CS317 CS317/2	1	1014	5

## NUMERICAL INDEX

PLATES ARE FROM PAGE 28 TO 70

PART NO.	PLATE NOS.	PART NO.	PLATE NOS.
1015	5	1072A	9
1016	5	1073	9, 19, 20, 21 & 22
1018A	6	1074	9
1019	6	1075	9, 19, 20, 21 & 22
1020	1, 6	1081	7
1021	6	1132	7
1022	6, 11	1134	7
1023	6	1139	2
1024	3	1143	2
1025	1, 3, 8	1144	2
1026	3	1146	2
1027	3	1146S	2
1028	3	1147	1
1029	3, 16	1158	8
1030	3	1160	10, 11, 12, 13
1031	1, 3, 8	1170	4
1034A	4	1181	7
1035	4	1182A	7
1036	4, 5, 19	1183	7
1037	4	1185	7
1039	4	1186	7
1040A	4	1187	7
1041A	4	1188	7
1041C	4	1189	7
1043	4	1195	1
1046	4	1196	1
1047	4	1200	1
1053	4	1201	1
1054	4	1203	1
1055	4	1205	13
1056	5	1206	12, 13
1057	19, 20, 21, 22	1210	1
1058	19, 20, 21, 22	1211	1
1059	5	1212	1
1060	5	1213	1
1066	9	1214	1
1067	9	1220	9
1071	9	1221	9
1072	9	1222A	18

NUMERICAL INDEX

PLATES ARE FROM PAGE 28 TO 70

PART NO.	PLATE NOS.	PART NO.	PLATE NOS.
✓ 1223	18	✓ <del>1383A</del>	129-18 16
✓ 1224	18	✓ <del>1383-1/2</del>	22508 16
✓ 1225	18	✓ 1384	16
✓ 1227 18-1045	18	✓ 1384-1/2	16
✓ 1244	12, 13	✓ 1388	16
✓ 1249	10, 11, 12	✓ 1413	10
✓ 1251	10, 11, 12	✓ 1414	10
✓ 1254	10, 11	✓ 1415	10
✓ 1256	10, 11	✓ 1417A	10
✓ 1260	10, 11, 13	✓ 1421	20
✓ 1261	10, 13	✓ 1432A	5
✓ 1262	10, 11, 13	✓ 1432-1/2A	5
<i>delete</i> ✓ 1263C 23-324	10	✓ 1436 41-55	Page 11
✓ 1263CA 42-324	10	✓ 1442	7
✓ 1272	16	✓ 1493	19
✓ 1273	11, 12, 16	✓ 1551	3
✓ 1288	12	✓ 1552	7
✓ 1303	10	✓ 1553	7
✓ 1304	10	✓ 1554	7
✓ 1309	10, 15	✓ 1555	7
✓ 1310	15	✓ 1556	7
✓ 1311	10, 11	✓ 1557	7
✓ 1326	18	✓ 1558S	7
✓ 1327	18	✓ 1571A	19
✓ 1328	18	✓ 1573	19
✓ 1329	18	✓ 1573-1/2	19
✓ 1329-1/2	18	✓ 1575	19
✓ 1330	18	✓ 1576	19
✓ 1330A	18	✓ 1577	19
✓ 1343A	20	✓ 1578	15
✓ 1343SA	20	✓ 1579	15
✓ 1346	20, 21, 22	✓ 1584	15
✓ 1348-1/4	20, 22	✓ 1591	15
✓ 1348B-1/4	20	✓ 1591-1/2	15
✓ 1349	20, 22	✓ 1592	15
✓ 1351	19, 20, 21, 22	✓ 1592-1/2	15
✓ 1357	15	✓ 1593A	19
✓ 1368OS	10	✓ 1593SA	19
✓ 1373A	20	✓ 1598-1/4	19
✓ 1373B	20, 22	✓ 1669	10, 11, 12
✓ <del>1373BA</del>	20		

1373SA

## NUMERICAL INDEX

PLATES ARE FROM PAGE 28 TO 70

PART NO.	PLATE NOS.	PART NO.	PLATE NOS.
✓ 1671	10, 11	✓ 24-288	10
✓ 1672	10, 11, 12	• 26-1	15
✓ 1673	10, 11, 12	• 26-148	4
✓ 1677A	10, 11	✓ 46-15	11, 13
✓ 1778	19	✓ 46-94	10, 11, 12
✓ <del>1802</del> 57-45	1	✓ 47-115	12
✓ 4-129	17	• 51-19	4
• 6-1	21	✓ 68-3	11
• 6-4	21	✓ 68-19	7
• 6-9	19	✓ 71-86	16
• 6-11	19	✓ 75-15	11
✓ 14-324	1	✓ 75-16	11
✓ 18-106	11	• 75-129	21
✓ 18-125	11	✓ 115-3	11
✓ 18-281	20, 21, 22	• 405-1	21
✓ 18-327	16	• 405-2	21
✓ 18-719	4	• 405-3	21
✓ 18-736	8	• 405-5	22
✓ 18-748	1	• 405-34	22
✓ 18-912	4	• 405-131	22
✓ 20-60	7	✓ 416-11	4
✓ 21-26	16	• 423-291	11
✓ 21-27	11	✓ 424-8	11
✓ 21-284	7	✓ 445-234	6
✓ 21-286	16	✓ 445-251	4
✓ 22-21	11	✓ 448-6	11, 13
• 22-241	4	✓ 470-6	11
• <del>23-291</del> 1589KL	11	• <del>4145-6</del> 61477	18
✓ 24-8	11		

