

**THIRD  
EDITION**



*Union Special*<sup>®</sup>  
INDUSTRIAL SEWING EQUIPMENT

**CATALOG NO. 194-4**

---

**STYLES**

<b>200-1</b>	<b>200-9</b>	<b>200-21</b>
<b>200-2</b>	<b>200-10</b>	<b>200-22</b>
<b>200-6</b>	<b>200-15</b>	<b>200-23</b>
<b>200-7</b>	<b>200-16</b>	<b>200-24</b>
<b>200-8</b>	<b>200-17</b>	<b>200-25</b>
<b>200-26</b>		<b>200-27</b>

---

**BUTTON SEWING MACHINE**

Catalog No. 194-4

INSTRUCTIONS

FOR

ADJUSTING AND OPERATING

LIST OF PARTS

Styles

200-1	200-9	200-21
200-2	200-10	200-22
200-6	200-15	200-23
200-7	200-16	200-24
200-8	200-17	200-25
200-26	200-27	

Third Edition

© 1962 and 1977

By

Union Special Corporation  
Rights Reserved in All Countries

**UNION SPECIAL CORPORATION**

INDUSTRIAL SEWING MACHINES

**CHICAGO**

Printed in U.S.A.

April, 1981

## IDENTIFICATION OF MACHINES

Each UNION SPECIAL LEWIS machine carries a style number, which in this class of machines, is stamped in the style plate on the left side of the arm.

The serial number of each machine is stamped in the right side of the cylinder toward the back.

### APPLICATION OF CATALOG

This catalog applies specifically to the styles of machines as listed herein.

All references to direction, such as right and left, forward and back, etc., are taken from the operator's position while seated at the machine.

The operating direction of the pulley is away from the operator.

### DESCRIPTION OF MACHINES

High production, single thread, button sewing machines. Sews all popular sizes and types of flat two hole, four hole, and shank buttons. Attachments available to sew snaps, hooks and eyes, and for tacking operations. Lever adjusted stitch range to sew 8, 16 or 32 stitches on some styles, and 6, 12, or 24 on others. Automatic stitching cycle, cam drive with stop motion clutch. Single treadle operation.

200-1 Right to Left Stitching Flat Buttons. For two or four hole buttons on blouses, coats, shirts, pajamas, and similar garments of light, medium and heavy materials. Sews right to left, 8, 16, or 32 parallel stitches. Equipped to sew buttons 14 to 45 ligne. Can be equipped to sew buttons 30 to 60 ligne when specified.

NOTE: 1 Ligne equals .025 inch. 40 Ligne equals 1 inch.

200-2 Same as Style 200-1, except sews 6, 12, or 24 stitches.

200-6 Diagonal Stitching Flat Buttons. Similar to Style 200-1, except sews 16 or 32 diagonal stitches in four hole buttons. Two hole buttons can be stitched right to left or back to front with 8 or 16 stitches.

200-7 Same as Style 200-6, except sews 6, 12, or 24 stitches.

200-8 Back to Front Stitching Flat Buttons. Same as Style 200-1, except sews 8, 16, or 32 parallel stitches back to front in two or four hole buttons.

200-9 Same as 200-8, except sews 6, 12, or 24 stitches.

200-10 Right to Left Stitching Flat Buttons With No Cross-over Stitch. Sews 16 parallel stitches in four hole buttons only. Equipped with special knife and nipper mechanism to cut cross-over stitch between the two rows of parallel stitches. Recommended for high quality garments, such as men's sack coats, suit coats, ladies' suits and coats.

200-15 Same as Style 200-1, except equipped with knife for cutting thread at end of stitch cycle. Primarily used with heavy thread where thread cutter is needed. Recommended with certain types of automatic button feeders and for use with necking attachment.

200-16 Tacking. Equipped with tacking clamp. Sews 8 or 16 stitches back to front. Recommended for tacking bows on blouses, dresses, etc., cuffs on trousers, side pockets on trousers, size tickets, and similar operations.

200-17 Same as Style 200-16, except sews 6 or 12 stitches.

200-21 For Hopper Fed Shank Buttons. Similar to Style 200-6, except prepared for and including Rochester Shank Button Hopper. Stitches back to front and sews 8, 16, or 32 stitches. Button Hopper handles self molded shank buttons from 14 to 30 ligne within other dimensions indicated on sketch on next page.

DESCRIPTION OF MACHINES (continued)

200-22 Same as Style 200-21, except sews 6, 12, or 24 stitches.

SIZES 14-30 LIGNE INCLUSIVE

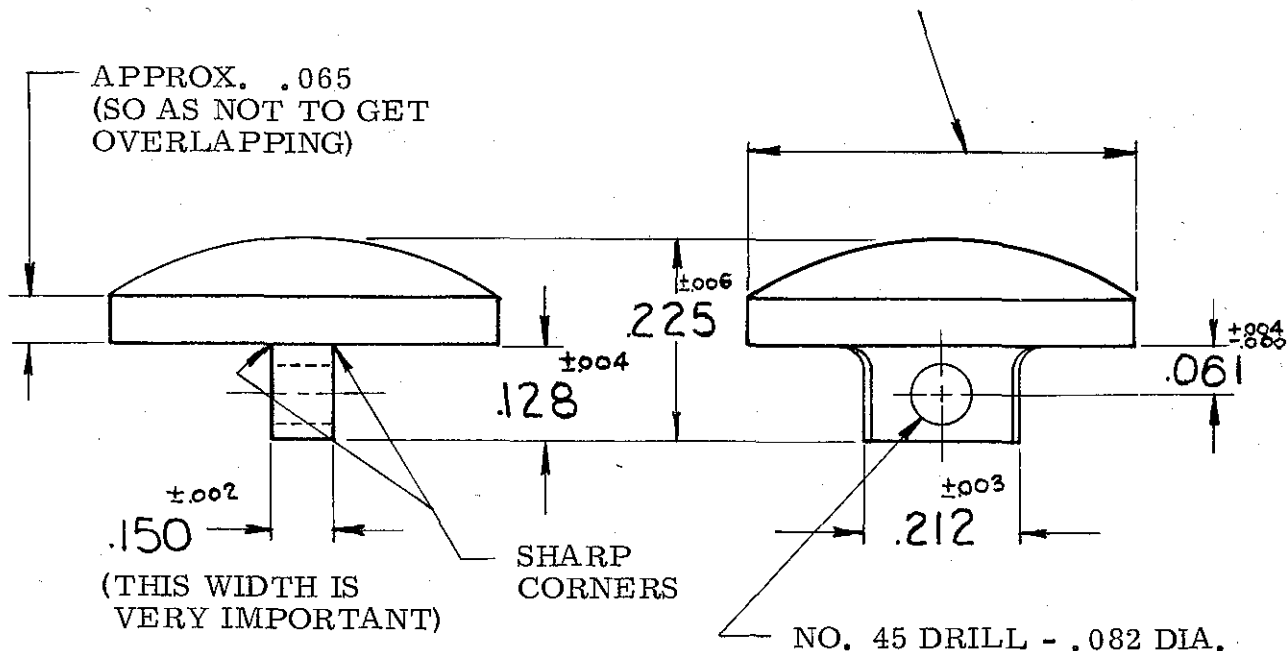

200-23 For Hopper Fed Flat Buttons. Similar to Style 200-1, except prepared to receive Rochester So-Thru Button Hopper. For use on shirts, pajamas, blouses, or any garments where continued use of similar size buttons is required. Stitches right to left on two or four hole buttons and sews 8, 16, or 32 stitches. No button clamp furnished. Sample button must be submitted with order. See Page 35 for list of available Rochester So-Thru Button Hoppers.

200-24 Same as Style 200-23, except sews 6, 12, or 24 stitches.

200-25 Right to Left Stitching Flat Buttons. For two hole buttons on dresses, blouses, coats, shirts, pajamas and similar garments of light, medium and heavy weight material. Sews right to left, 16 or 32 parallel stitches. Can also be used for 16 stitches on four hole buttons and when used this way, the cross-over stitch will be diagonal and there is no tacking stitch previous to cross-over. Machine cannot be used 1/2 cycle or 8 stitches. Equipped to sew buttons 14 to 45 ligne.

200-26 Same as Style 200-1, except sews right to left, 12 or 24 parallel stitches. Produces 12 stitches on two hole buttons in the half cycle. It also may be used to produce 24 stitches on four hole buttons in the full cycle. Equipped to sew buttons 14 to 45 ligne.

200-27 Right to Left Stitching Shank Buttons. For shank buttons on dresses, blouses, coats, shirts, pajamas and similar garments of light, medium and heavy weight material. Sews right to left, 8, 16, or 32 parallel stitches. Equipped to sew shank buttons 10 to 40 ligne.

OTHER APPLICATIONS

By the selection of the proper attachments, listed and illustrated in the Parts section of this book, many of these machine Styles can be used for operations other than those for which they are described. A list of these variations follows:

200-1 Can be used for shank buttons, snaps, hooks and eyes, tacking, shanking, and necking operations.

200-2 Same variations as for Style 200-1.

## OTHER APPLICATIONS (Continued)

- 200-6 Can be used for shank buttons, hooks and eyes, drapery rings, tacking, shanking, and necking operations.
- 200-7 Same variations as for Style 200-6.
- 200-8 Can be used for snaps, drapery rings, tacking, and shanking operations.
- 200-9 Same variations as for Style 200-8.
- 200-10 Can be used for shanking operations.
- 200-15 Can be used for shank buttons, snaps, hooks and eyes, tacking, shanking, and necking operations.
- 200-16 Can be used for two hole buttons, stitched back to front only, and drapery rings.
- 200-17 Same variations as for Style 200-16.

## OILING

These machines should be oiled twice daily, before the morning and afternoon starts. Use a good grade of straight mineral oil of a Saybolt viscosity of 90 to 125 seconds at 100° Fahrenheit.

Most of the oiling places on the machines are readily identifiable because of the fact they are painted red. However, reference to the oiling diagram Fig. 13, on Page 14, will be beneficial.

Please note that it will be necessary to remove arm cover and side cover, and to open the hinged base covers and tilt machine on its side to reach some of the oiling places.

Also note that there is a label on the pulley which reads "Grease Here". A tube of grease is furnished with the machine, and periodically, the plug screw in the pulley should be removed, the grease level checked and replenished if required. The greasing place is indicated by the letter "A" in the diagram. All other places shown are oiled.

Tubes of grease may be ordered under part No. 28604 P.

## SPEED

The recommended speed of these machines is 1500 R.P.M.

## NEEDLES

Needles for these machines are divided into three categories - short, long with short shank, and long with extra short shank.

Generally speaking, the shortest needle required to perform a given operation should be used. In making the selection, consideration should be given to the height of the button, thickness of material, amount of shanking required, and whether or not a stay button is to be used.

## NEEDLES (Continued)

For shank buttons, the diameter of the button, the thickness of the shank, and the height of the work support block should be considered.

Available needles for the Class 200 machines are:

Blade Dia.	Short	Long With Short Shank	Long With Extra Short Shank	Extra Long With Extra Short Shank
.036"	29S-090/036	29LSS-090/036	-	-
.040"	29S-100/040	29LSS-100/040	29LES-100/040	-
.044"	29S-110/044	29LSS-110/044	29LES-110/044	29ELS-110/044
.049"	29S-125/049	29LSS-125/049	29LES-125/049	29ELS-125/049
.057"	-	29LSS-140/054	-	-

For use with large diameter shank buttons, and high work support block, the long needle with extra short shank is recommended.

For use with extra large diameter shank buttons and high work support block, the extra long needle with extra short shank is recommended.

In changing from short to long needles, or vice versa, the needle bar height must be set to the proper timing lines as described in the adjusting instructions in this catalog.

Unless instructions to the contrary are received, machines in Class 200 will be sewed off and shipped with the following needle specifications:

Machine Style	Needle	Machine Style	Needle
200-1	29S-100/040	200-17	29S-110/044
200-2	29S-100/040	200-21	29LSS-110/044
200-6	29LSS-110/044	200-22	29LSS-110/044
200-7	29LSS-110/044	200-23	29S-100/040
200-8	29LSS-110/044	200-24	29S-100/040
200-9	29LSS-100/040	200-25	29S-100/040
200-10	29LSS-110/044	200-26	29S-100/040
200-15	29S-100/040	200-27	29LES-110/044
200-16	29S-110/044		

Selection of proper needle size is determined by size of thread, weight of material, and the type of button used.

To have needle orders promptly and accurately filled, an empty container, a sample needle, or the type number should be forwarded. A complete order would read: "100 Needles, Type 29LSS-110/044".

### CHANGING NEEDLES

When changing the needle, make sure that it is inserted in the needle bar as far as it will go, with the long groove to the front and the spot or scarf to the rear, and tighten set screw securely.

A cross hole drilled in the needle bar can also be used to determine if the needle has been inserted as far as it will go.

Immediately discard any needle which may have a hooked or blunt point.

## THREADING

To thread machine, put in stop position, and thread in accordance with diagram Fig. 13, Page 14.

## ADJUSTING

**CAUTION!** Do not run the machine under power during the following adjusting operations until ready to sew.

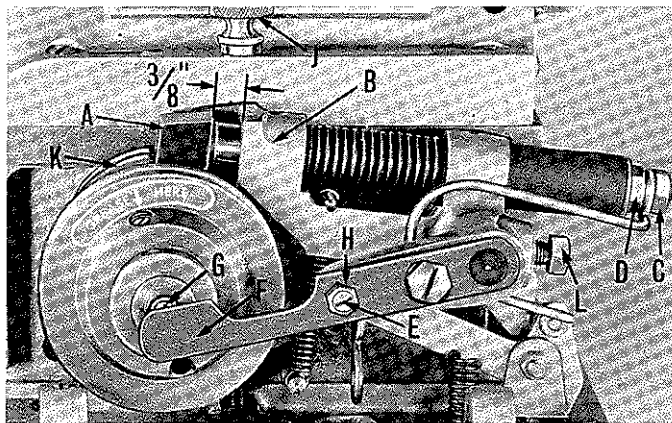

Fig. 1

operated, depress the operating treadle, and turn the pulley and stop motion disc in operating direction.

The Class 200 machines are equipped with a cycling mechanism, which, with one pressure on the operating treadle, produce 6, 12, 24, or 8, 16, 32 stitches and automatically stops.

In the following instructions, reference is made to "the machine in stop position".

This position is that which is shown in Fig. 1 with the stop motion disc and pawl (K) against the plunger (A).

To release the machine from stop position so that it may be manually

## ADJUSTING CLUTCH

With the machine in stop position, the stop motion plunger (A, Fig. 1) should be set so that there is  $\frac{3}{8}$  inch clearance between the bottom of the plunger and the plunger lever bracket (B). Loosen the back lock nut (C), and adjust the front nut (D) to obtain this setting. Lock the back nut. Adjust screw (E) in cam lever (F) so that there is  $\frac{1}{32}$  inch clearance between ball (G) and the thin section of lever (F) when the pulley is pressed in towards machine. Lock screw with nut (H). Make sure that set screw (L) is securely tightened.

## ADJUSTING STOP MOTION (PRIOR TO SER. NO. 1368377)

With the machine in stop position, loosen the two socket head set screws (A, Fig. 2) in stop motion cam (B) and rotate cam to secure  $\frac{1}{32}$  inch clearance between roller (C) and front of slot in cam.

Depress the treadle to take machine out of stop position, and rotate pulley two complete revolutions in operating direction. Release treadle and measure distance between plunger (A, Fig. 3) and highest point on disc (B). The distance should be  $\frac{3}{32}$  inch.

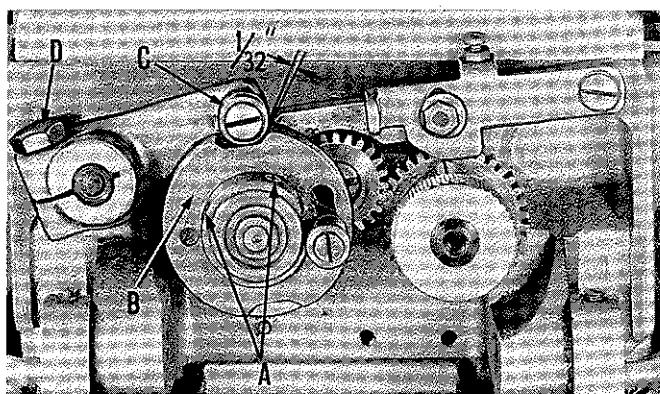

Fig. 2

This adjustment is made by loosening clamp screw (D, Fig. 2) in stop motion trip lever and moving lever up or down to secure the  $\frac{3}{32}$  inch clearance. Should it be necessary to move lever down, depress the treadle while making adjustment.

## ADJUSTING STOP MOTION (Continued)

Effective with Serial No. 1368377, an "improved" Stop Motion Cam and Gear Assembly has been incorporated, for which the following instructions apply:

With the machine in stop position, loosen the two socket head set screws. (A, Fig. 2A) and screw (B). Rotate "left cam" (C) counterclockwise to the top of its elongated slot (as viewed in Fig. 2A) and tighten screw (B). Rotate cam (C) and "right cam" (D) as required to obtain 1/32 inch clearance between roller (E) and the front of slot in cam (D); tighten set screws (A).

**NOTE: 1.** This dimension MUST remain constant; regardless of other related or associated adjustments.

Depress the treadle to take machine out of stop position, then rotate pulley two complete revolutions in operating direction. Release treadle and measure the distance between plunger (A, Fig. 3A) and the highest point on disc (B). The distance should be 1/4 inch. Adjustment can be made by loosening clamp screw (F, Fig. 2A) in the stop motion trip lever and moving lever up or down to attain specified clearance. Should it become necessary to move the lever down, depress the treadle while making adjustment. Retighten clamp screw (F).

### SOFT STOP ADJUSTMENT

- Step 1. With the machine in stop position, loosen screws (A, Fig. 2A) and screw (B). Advance "left cam" (C) by rotating it clockwise, SLIGHTLY, relative to the "right cam" (D). Retighten screws (A and B) after referring to NOTE 1 above.
- Step 2. Operate the machine and check the stop motion performance. When adjusted properly, the impact and noise will noticeably decrease when the machine stops. Should this condition still not exist, repeat Step 1.
- Step 3. Should disc and pawl (K, Fig. 1) stop short of plunger (A), (this can be checked by rotating disc towards the operator and if the plunger does not catch the disc and pawl, the machine has not reached its stopped position), denoting cam is advanced beyond proper setting. To correct: retard "left cam" (C, Fig. 2A) by rotating it counterclockwise, SLIGHTLY, relative to the "right cam" (D). Refer to NOTE 1 above, before securing screws (A and B).

**NOTE: 2.** With reference to (A, Fig. 5) under "STITCH SETTINGS", the stitch adjusting knob has been replaced by screw (G, Fig. 2A) which secures cam shoe (H) using the upper or lower hole in "left cam" (C), as applicable.

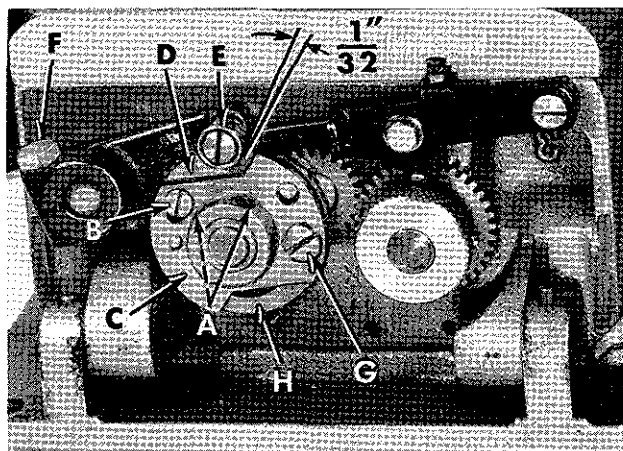

Fig. 2A

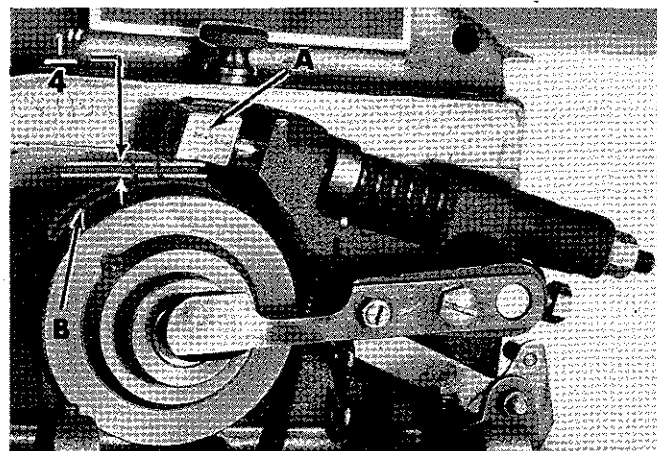

Fig. 3A



## TIMING CAMS

Depress treadle to take machine out of stop position, and rotate pulley two complete revolutions in operating direction. Loosen knurled screw (J, Fig. 1) and lay machine on its side.

Turn pulley in operating direction until first screws in cams (A, Fig. 4) coming into view are accessible, and loosen these two screws. Continue to turn pulley in operating direction until machine is again in stop position and screws (B) are in view.

Loosen the two screws (B) and turn cams (A) in either direction to align timing lines (C) on cams with timing pins (D) in bed. Retighten all four cam screws securely.

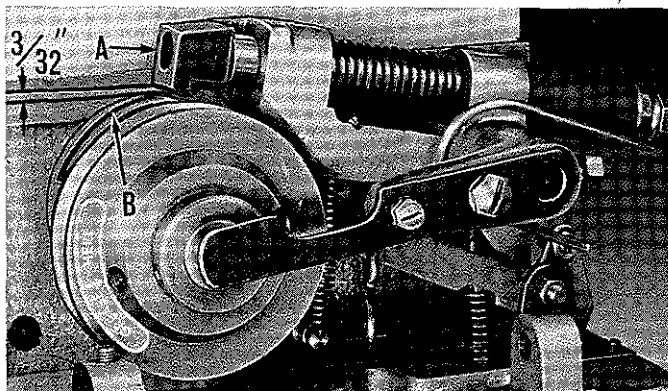

Fig. 3

## ADJUSTING CLAMP LIFTING LINK

The button clamp lifting link (E, Fig. 4) is in proper position, when, with the machine in stop position, the lip on the fork lever (F) is engaged in the slot of the link.

Forward and backward adjustment of the link is accomplished by loosening clamp screw (G) in lever (H) and moving lever on shaft.

Adjustment of the fork lever (F) is made by loosening screws in collars (J) and moving fork lever on shaft.

## COMBINATIONS OF STITCHES AVAILABLE

The cams and gears furnished with the Class 200 machines will produce 6, 12, or 24 stitches or 8, 16, or 32 stitches, depending on the Style. These combinations are obtained as follows:

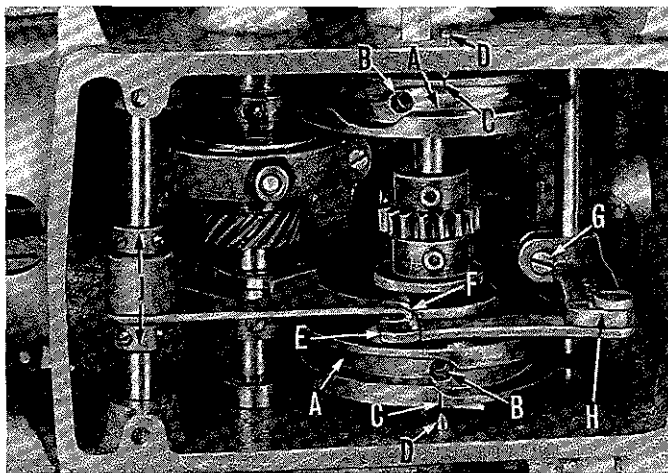

Fig. 4

1. With one half cycle of cam shaft, 6 or 8 stitches per button. Cannot be used for four hole buttons.
2. With one cycle of cam shaft, 12 or 16 stitches per button.
3. With two cycles of cam shaft, 24 or 32 stitches per button.

## SETTING FOR SIX OR EIGHT STITCHES

Figure 5 shows the machine in stop position, and set for 12 or 16 stitches. The stitch adjusting knob (A) is at its low position at the bottom of the slot and the gap (B) is closed. To change to 6 or 8 stitches, simply pull out on the stitch adjusting knob (A) and raise it to the top of the slot. At this point, the gap (B) will be open.

## SETTING FOR SIX OR EIGHT STITCHES (continued)

When setting for 6 or 8, or 12 or 16 stitches, the latch (C) must be set as high as possible in relation to the lever (D). To make this adjustment, loosen screw (E), hold lever (D) down, raise latch (C) as high as it will go, and retighten screw (E).

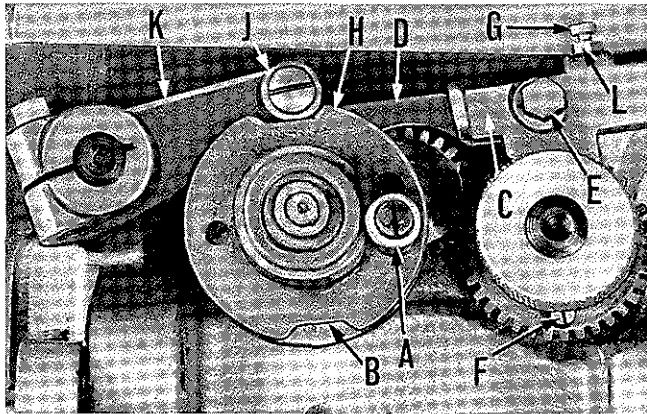

Fig. 5

## SETTING FOR TWELVE OR SIXTEEN STITCHES

When changing from 6 or 8 to 12 or 16 stitches, the machine must be in stop position with the stitch adjusting knob (A, Fig. 5) towards the front. Pull out on the stitch adjusting knob (A) and move it to the bottom of its slot as shown in Fig. 5. Gap (B) will now be closed.

## SETTING FOR TWENTY FOUR OR THIRTY TWO STITCHES

When changing from 6 or 8, or 12 or 16, to 24 or 32 stitches, the machine must be in stop position with stitch adjusting knob (A, Fig. 5) to the front. If the machine is in the 6 or 8 stitch position, pull out on the stitch adjusting knob (A) and move it to the bottom of its slot. Check position of screw (F). It should be at the bottom as shown in Fig. 5. If it is not, the machine will have to be re-cycled once to bring screw (F) into proper position.

Loosen screw (E) and move latch (C) down as far as it will go. Retighten screw (E).

If, after this adjustment, the machine does not cycle properly, the position of the stop screw (G) must be adjusted. To do this, loosen screws (E and G) in latch (C). Turn pulley in operating direction until outside front corner of gap (H) is under the roller (J) and the screw (F) is at the top. Raise lever (D) against lever (K), move latch (C) down against screw (F), and tighten screw (E). Run screw (G) lightly down against lever (D) and lock with nut (L).

## ADJUSTING NEEDLE BAR

When using short needles, use the upper pair of timing lines on the needle bar; for long needles, use the middle pair of timing lines; for extra long needles, use the lower pair.

Take machine out of stop position, and turn pulley two complete revolutions in operating direction.

With the needle bar in its lowest position, the upper line of each pair of timing lines (A, Fig. 6), depending on which length of needle is used, should be even with the lower edge of the needle bar bushing.

To raise or lower needle bar, loosen needle bar clamp screw (B) and take-up clamp screw (C), move bar to desired height, and retighten screws. The take-up clamp must rest against the needle bar clamp.

The needle bar is correctly positioned when the needle set screw (D) enters the slot in the needle bar bushing freely.

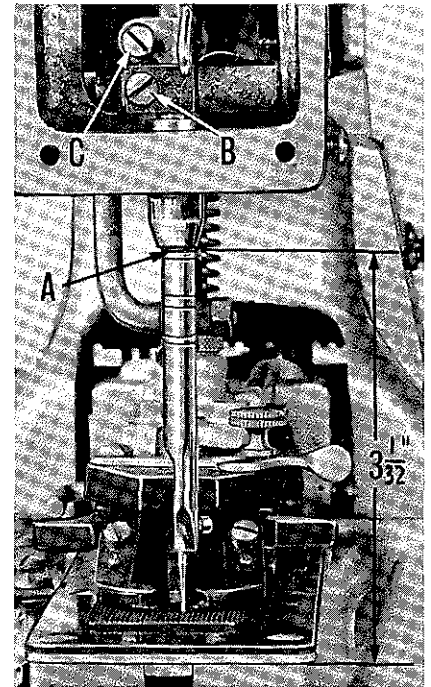

Fig. 6

## ADJUSTING NEEDLE BAR (continued)

The position of the needle bar bushing is set to a gauge at the factory. The distance from its lower edge to the machined surface of the cylinder base is  $3 \frac{1}{32}$  inches.

### ALIGNING FEED PLATE

Make sure that the feed plate (A, Fig. 7) is set so that it does not interfere with the needle at any point of its travel.

Adjustment is made by loosening two screws (B) and moving feed plate to desired position.

### TIMING NEEDLE WITH HOOK

NOTE: Fig. 8 shows the machine with needle plate, feed plate, and button clamp removed. This has been done for clarity only. These parts need not be removed to make the adjustments.

Take machine out of stop position, and rotate pulley two complete revolutions in operating direction. Lower the needle bar until it reaches its lowest position, then, raise it until the lower edge of the needle bar bushing is midway between the upper pair of timing lines on the bar when using short needles. (When the machine is equipped with long needles, use the lower pair of timing lines.)

Loosen needle guard clamp screw (A, Fig. 8) and slide needle guard (B) forward. Insert a screw driver behind the loop positioning finger (C) and pull the finger forward. There should be only the slightest amount of clearance between the finger and needle, approximately .002 inch.

To make this adjustment, loosen set screws (A, Fig. 9) in the sleeve (B), slide sleeve forward slightly and retighten one of the screws enough to prevent the sleeve sliding on the shaft during adjustment. Now, loosen screws (C) in cam (D) and slide cam in the direction necessary to secure the proper clearance between the loop positioning finger and the needle. Tighten one of the screws in the cam and slide the sleeve back so that it contacts the cam.

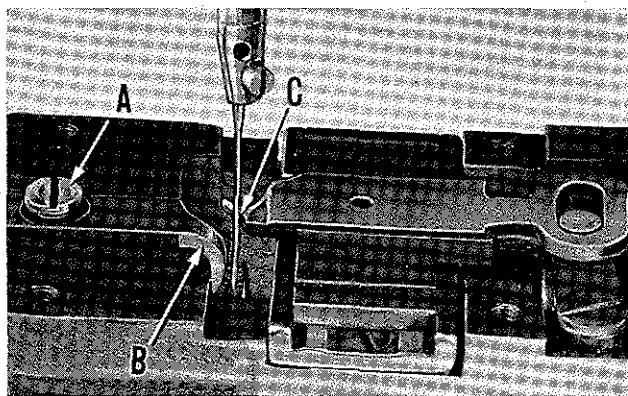

Fig. 8

Rotate the pulley in operating direction until the lower timing line on the needle bar is even with the lower edge of the needle bar bushing. Rotate the sleeve (B) so that the point of the hook is at the center of the needle on the back side and tighten both screws (A) in the sleeve. Loosen hook collar clamp screw (E), and slide hook (G) so that there is the smallest amount of clearance between its point and the needle, and retighten hook collar clamp screw. Loosen set screw (C) in cam (D), and rotate cam so that its timing line coincides with the timing line on the sleeve (F). Tighten screws in cam, making sure that the cam is against the sleeve. Turn the pulley in operating direction until the needle bar is at its lowest position, and slide the needle guard (B, Fig. 8) in the direction of the needle until there is a clearance of about .002 inch between it and the needle. Retighten clamp screw (A) securely.

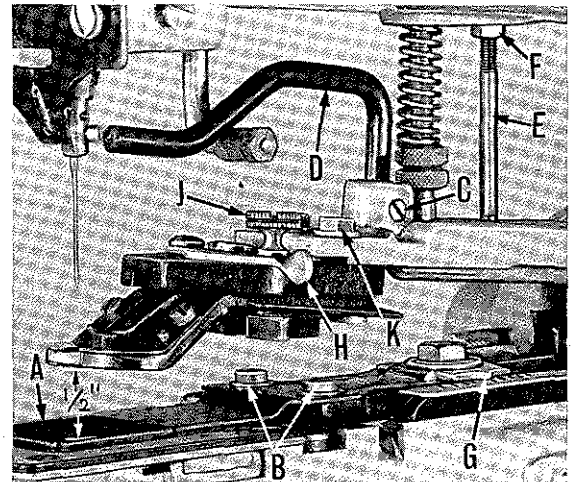

Fig. 7

## HEIGHT OF BUTTON CLAMP

With the machine in stop position, the normal distance between the bottom of the button clamp to the top of the feed plate should be  $1/2$  inch (Fig. 7). To make this adjustment, loosen set screw (C), and raise or lower rod (D).

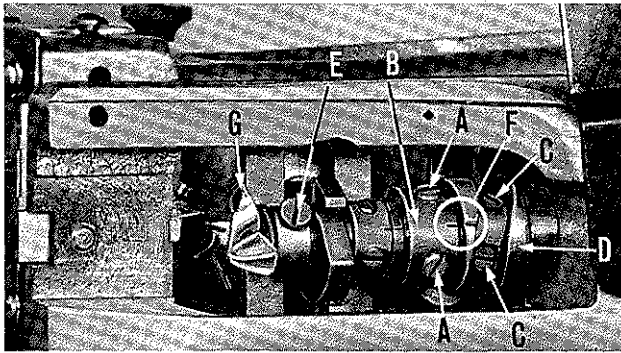

Fig. 9

Take machine out of stop position, and turn pulley in operating direction until button clamp is in its furthest position to the rear. At this point, there must be clearance between the button clamp lifting rod (A, Fig. 10) and the button clamp lifting roller (B). Adjustment is made by loosening screw (C) and moving rod (A) up. This will affect the height of the button clamp in relation to the feed plate as previously described, but for the normal setting of  $1/2$  inch, no interference between lifting rod and roller will occur.

Return the machine to stop position, and check the position of the button clamp stop pin (E, Fig. 7). Its purpose is to prevent overthrow of the button clamp so that the needle will not strike the button or any other part of the button clamp. Insufficient clearance between the stop pin and the button clamp holder will cause the machine to re-cycle. Too much clearance will cause the button to strike the needle.

On Styles 200-16, 200-17, which are equipped with a tacking clamp instead of a button clamp, the tacking clamp should be set so that there is a distance of approximately  $1/2$  inch between it and the feed plate with machine in stop position. Position of the clamp can be changed by loosening lock nut and turning clamp rod in or out to desired height. The clamp holder will have to be removed to make this adjustment.

The stop pin, corresponding to (E, Fig. 7), should be set only as low as necessary to drop the feed plate holder off the latch when the machine has reached stop position.

## POSITIONING AND ADJUSTING BUTTON CLAMP

### FOR FOUR HOLE BUTTONS

Accurately measure the distance between the holes of the button, and set the pivot indicator (G, Fig. 7) and spring indicator (A, Fig. 11) to the graduations corresponding to the distance between the holes in the button.

With the machine in stop position, insert the button in the jaws of the clamp, and adjust the stop lever (H, Fig. 7) by means of screw (J) so that the button is held loosely by the jaws.

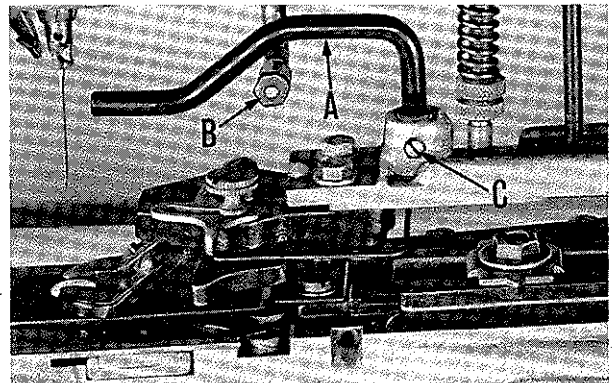

Fig. 10

Take the machine out of stop position, and turn slowly by hand to make sure that the needle enters the center of each hole in the button. The button clamp may have to be shifted slightly to secure this condition. Loosen screws (K) to make the adjustment.

The graduations on the indicator scales are only approximate, and it may be necessary to deviate slightly from them.

## POSITIONING AND ADJUSTING BUTTON CLAMP (continued)

### FOR TWO HOLE BUTTONS

Set pivot indicator (G, Fig. 7) to proper graduation on scale corresponding to distance between holes of button, and set spring indicator (A, Fig. 11) on circle with two dots at left end of scale (B). Continue with adjustment of button clamp the same as for four hole buttons.

When sewing two hole buttons from back to front on Styles 200-6, 200-7, set pivot indicator (G, Fig. 7) and spring indicator (A, Fig. 11) to the proper graduations on scales, corresponding to distance between holes of button. Push in the lever located under the spring indicator (A, Fig. 11). This lever is not illustrated.

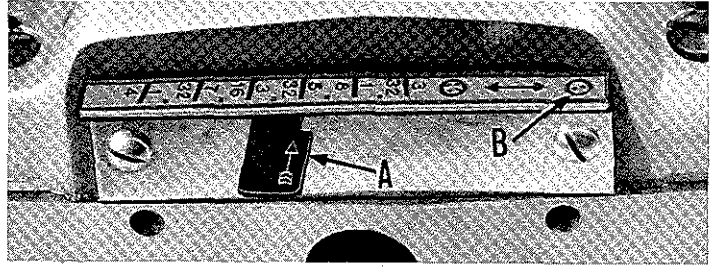

Fig. 11

### THREAD TENSION

The regular thread tension (A, Fig. 12) is located behind the automatic thread tension (B) and controls the tightness of the button. The tension required will vary in relation to the types of thread, materials, and thickness of buttons used. Normally, only a light tension is required.

Take machine out of stop position, rotate pulley two complete turns in operating direction, and thread machine in accordance with threading diagram (Fig. 13).

Check the position of the tension releasing lever (C, Fig. 12) to see that it comes as close as possible to the tension discs (D) without contacting them. Adjustment is made by loosening screw (E) and moving the lever (C) in the required direction. In the illustration (Fig. 12), another tension releasing lever (F) is shown. This lever is used only on Style 200-10, and is adjusted in relation to the automatic tension discs in the same manner in which lever (C) is adjusted for the regular tension discs. Loosen screw (G) to make this adjustment.

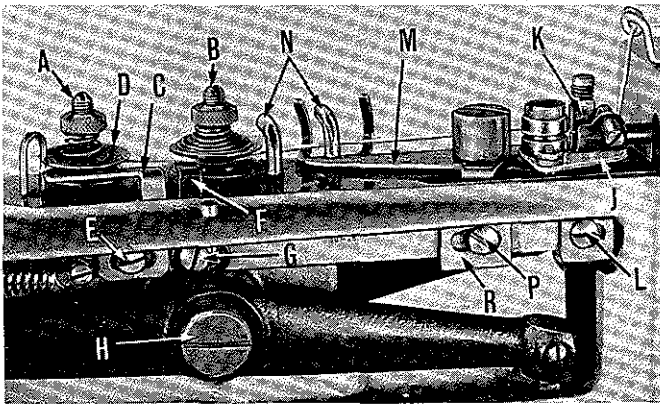

Fig. 12

using short needles. When using long needles, the needle bar must be allowed to rise until dimension "X" is  $1 \frac{15}{16} + \frac{1}{32}$  inch. For extra long needles, this dimension should be  $2 \frac{1}{8} + \frac{1}{32}$  inch.

To make this adjustment, turn pulley in operating direction until the needle bar has risen to the heights described above. Loosen the two hexagonal head screws (B) in needle lever hub and turn needle lever shaft (H, Fig. 12) with a screw driver until the tension releases.

### AUTOMATIC THREAD TENSION

The automatic tension controls the tightness of the stitch on the under side of the fabric.

With the tension nut (A, Fig. 14) turned down about four or five turns, the automatic thread tension should release the thread when the needle bar, on its upstroke, has risen to a point where the lower edge of its bevelled top is  $1 \frac{9}{16} + \frac{1}{32}$  inch above the top edge of the upper needle bar bushing as shown at dimension "X" (Fig. 14) on machines

**THREADING AND OILING  
DIAGRAM FOR  
LEWIS CLASS 200**

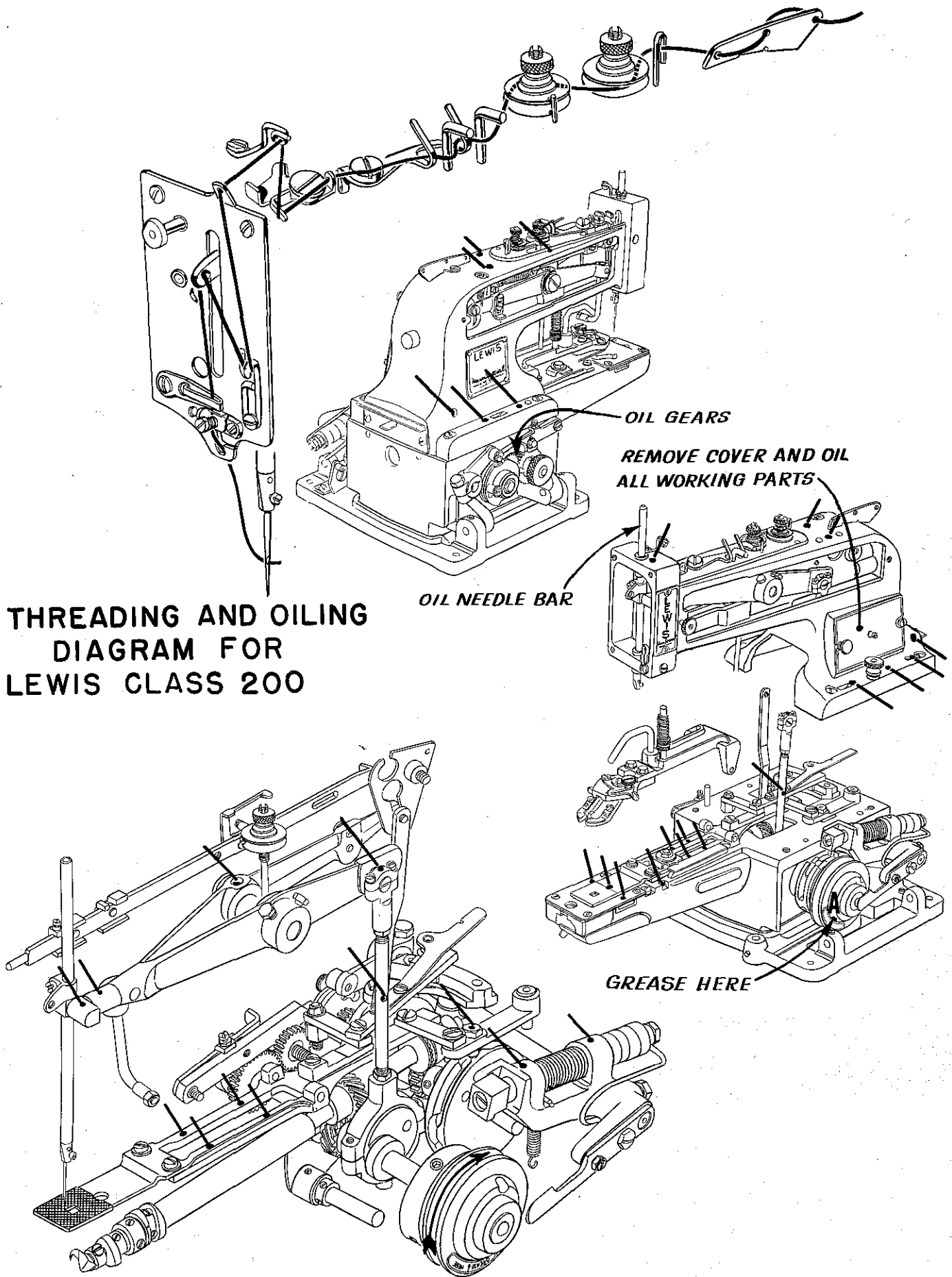

Fig. 13



## AUTOMATIC THREAD TENSION (continued)

Hold the needle lever shaft in this position while retightening the two hexagonal head screws (B, Fig. 14). This is an extremely important adjustment, and should be re-checked.

If, after re-checking, it is found that excessively large loops still exist on the underside of the fabric, the situation can be helped by applying more tension at tension nut (A, Fig. 14).

### THREAD NIPPER

The thread nipper (J, Fig. 12) pinches and holds the thread so that the raising of the button clamp at the conclusion of the sewing cycle will break off the thread at the button. On Style 200-10, the thread nipper also pinches and holds the thread at the middle of the sewing cycle so that the knife can cut the cross-over stitch.

The thread nipper should be set so that there is  $3/64$  inch clearance between it and the nipper block (K) when the nipper is open. Loosen screw (L) and move the nipper (J) in the required direction to make the adjustment.

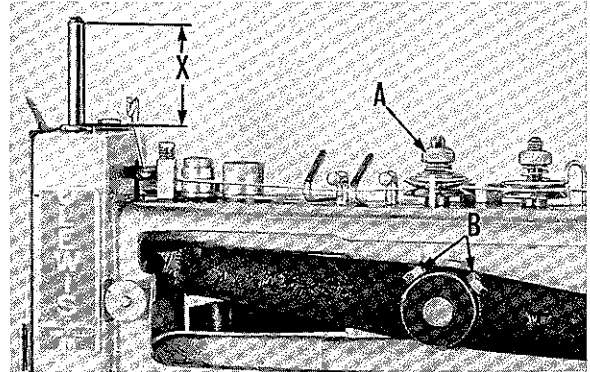

Fig. 14

### THREAD PULL-OFF LEVER

The thread pull-off lever (M, Fig. 12) controls the amount of thread which is pulled through the tensions, at the end of a stitching cycle, to provide sufficient thread for the first stitch of the following cycle.

With the machine out of stop position, there should be no contact between the pull-off lever (M) and the thread, when the thread is pulled taut against the thread guides (N).

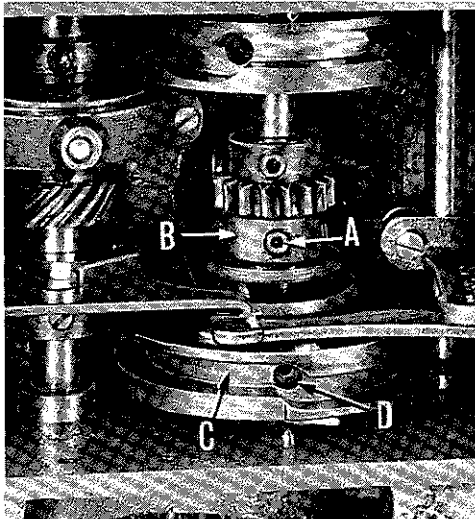

Fig. 15

This adjustment is made by loosening screw (P) and moving block (R) forward or back.

If, when sewing, too much thread tail is visible on the right side of a two hole button, or the right rear of a four hole button, move the pull-off lever to the right as described above.

If too much thread tail is visible on the left side of a two hole button, or the left rear of a four hole button, move the pull-off lever to the left.

On Style 200-10, the pull-off lever has an additional adjustment which causes it to function in the middle of the cycle during the cutting of the cross-over stitch. Loosen three socket head screws (A, Fig. 15) in cam (B).

Place machine in stop position for starting point of subsequent adjustment.

Take machine out of stop position and turn pulley in operating direction until needle has entered feed plate seven times. Continue turning pulley until needle bar has risen to a point where the lower edge of its bevelled top is  $1 \frac{7}{8}$  inches from the top of the upper needle bar bushing (see dimension "X", Fig. 14).

## THREAD PULL-OFF LEVER (continued)

Turn cam (B, Fig. 15) to the right, as you face it, until the lobe stops against the projection on the nipper operating link, and retighten three socket head screws (A).

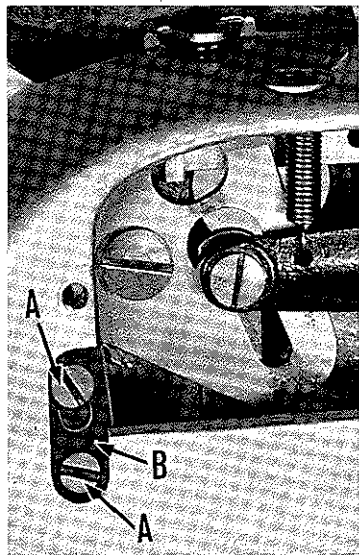

Fig. 16

The length of thread tails on the front holes of buttons is controlled, on Style 200-10, by an additional adjustment to the pull-off lever.

If too much thread tail is visible on the right front hole, loosen screws (A, Fig. 16) and raise the link (B). For easier access to link, remove right side cover.

## TIMING THE KNIFE

On Style 200-10, the knife should cut the cross-over stitch at the middle of the cycle.

Take machine out of stop position and turn pulley in operating direction until needle has entered feed plate eight times. Continue turning pulley until needle bar has risen to the top of its stroke. At exactly this point, the knife should snap out of operating position.

To make corrections to knife timing, place machine in stop position for starting subsequent adjustment. Take machine out of stop position and turn the pulley two complete revolutions in operating direction. Loosen knurled base clamping screw and lay machine on its side. Turn pulley in operating direction until the first screw in cam (C, Fig. 15) comes into view, and loosen this screw. Continue to turn pulley until machine is again in stop position, and loosen screw (D). Turn cam (A) slightly to right to speed up knife timing, and to the left to retard it. Tighten all screws securely.

The slight amount of adjustment required for this setting will have no noticeable effect on previous timing of the cams described on Page 9.

On Style 200-15, the knife should cut the thread at the end of the stitching cycle.

The knife should snap out of operating position when the needle bar has risen to within 1/16 inch of the top of the last up-stroke in the cycle.

Changes to timing are made in the same manner as described for Style 200-10.

## POSITIONING THE KNIFE

To position knife, loosen screws (A, Fig. 17), and move bar (B) in or out.

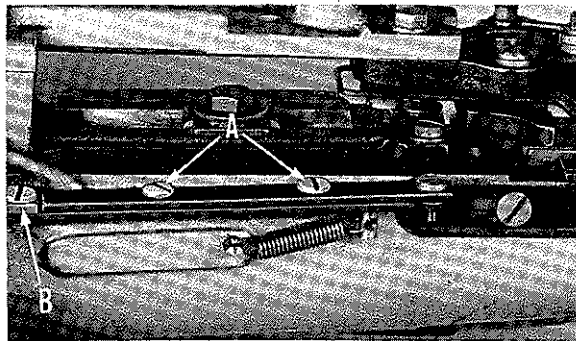

Fig. 17



## ORDERING REPAIR PARTS

### ILLUSTRATIONS

This catalog has been arranged to simplify ordering repair parts. Exploded views of various sections of the mechanism are shown so that the parts may be seen in their actual position in the machine. On the page opposite the illustration will be found a listing of the parts with their part number, description and the number of pieces required in the particular view being shown.

Numbers in the first column are reference numbers only, and merely indicate the position of that part in the illustration. Reference numbers should never be used in ordering parts. Always use the part number listed in the second column.

Component parts of sub-assemblies which can be furnished for repairs are indicated by indenting their descriptions under the description of the main sub-assembly. Example:

45	4124-49	Ball Joint, lower, complete -----	1
46	18-968	Spot Screw -----	1
47	18-730	Set Screw -----	1
48	18-925	Screw -----	2
49	666-19	Oil Wick -----	1
50	137-19	Oil Wick Retainer -----	1

It will be noted in the above example that the eccentric and strap are not listed. The reason is that replacement of these parts individually is not recommended, so the complete sub-assembly should be ordered.

At the back of the book will be found a numerical index of all the parts shown in this book. This will facilitate locating the illustration and description when only the part number is known.

### IDENTIFYING PARTS

Where the construction permits, each part is stamped with its part number. Part numbers represent the same part, regardless of catalog in which they appear.

### USE GENUINE REPAIR PARTS

Success in the operation of these machines can be secured only with genuine UNION SPECIAL Repair Parts as furnished by the Union Special Corporation, its subsidiaries and authorized distributors. They are designed according to the most approved scientific principles, and are made with utmost precision. Maximum efficiency and durability are assured.

### TERMS

Prices are net cash and subject to change without notice. All shipments are forwarded f.o.b. shipping point. Parcel Post shipments are insured unless otherwise directed. A charge is made to cover postage and insurance.

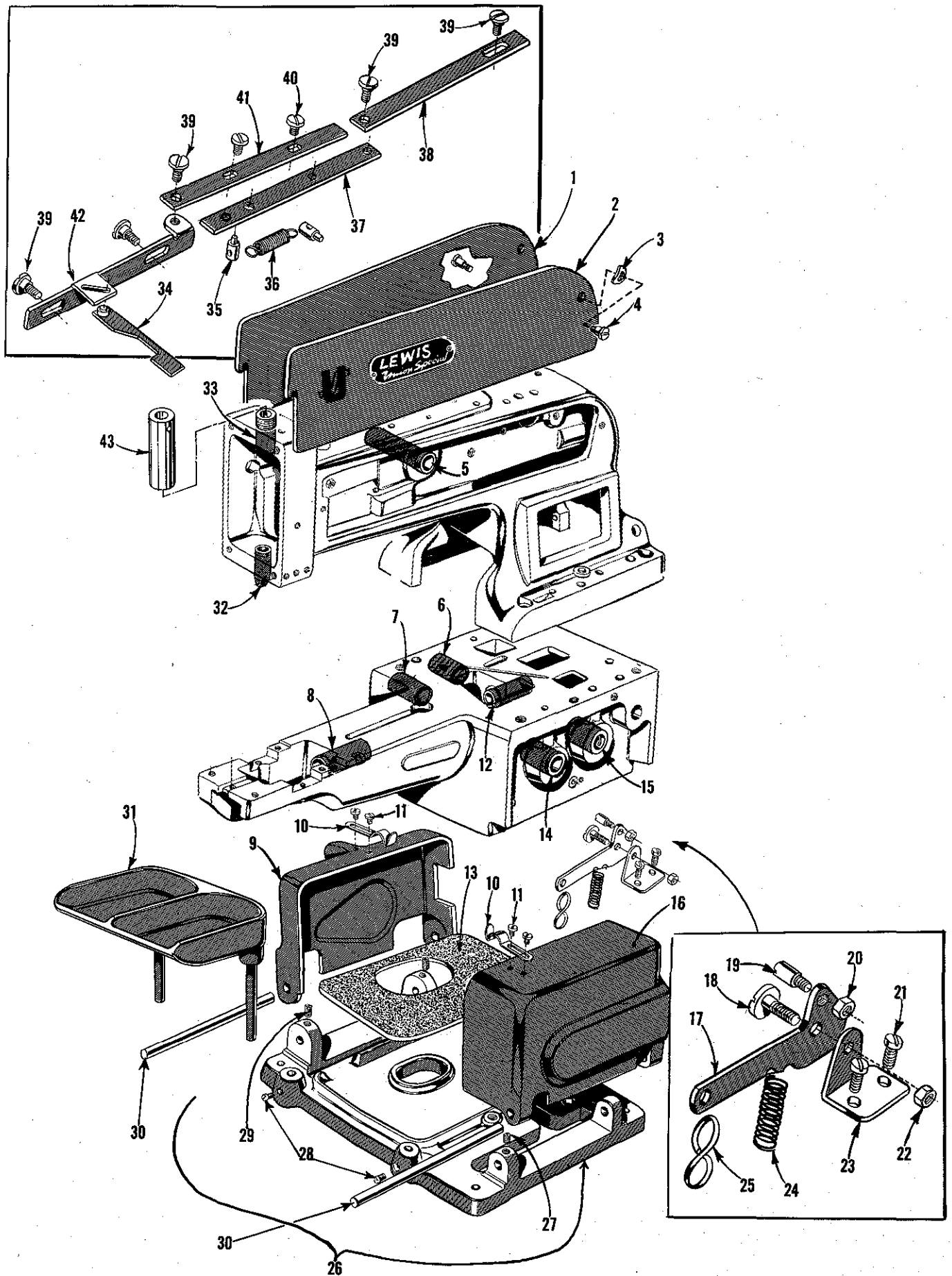

BASE, COVERS, BUSHINGS

<u>Ref. No.</u>	<u>Part No.</u>	<u>Description</u>	<u>Amt. Req.</u>
1	432-306	Arm Cover, left -----	1
2	432-305	Arm Cover, right -----	1
3	12957 E	Washer -----	2
4	1220 L	Screw -----	2
5	16-412	Needle Lever Shaft Bushing -----	1
6	16-291	Cam Shaft Bushing, left -----	1
7	16-289	Pulley Shaft Bushing, left -----	1
8	16-292	Looper Shaft Bushing, front -----	1
9	32-192	Cover, left -----	1
10	21-295	Spring -----	2
11	CS337	Screw -----	4
12	16-334	Looper Shaft Bushing, rear -----	1
13	144-25	Felt Pad -----	1
14	16-288	Pulley Shaft Bushing, right -----	1
15	16-398	Cam Shaft Bushing, right -----	1
16	32-191	Stop Motion and Pulley Cover, right -----	1
17	45-333	Stop Motion Trip Lever -----	1
18	1235 L	Screw -----	1
19	787 L	Stop Screw -----	1
20	1160 L	Nut -----	1
21	1158 L	Screw -----	2
22	1009 L	Nut -----	1
23	50-215	Bracket -----	1
24	21-321	Spring -----	1
25	131-C163-2	"S" Chain Hook -----	1
26	141-4	Machine Sub-Base -----	1
27	1005 L	Set Screw -----	1
28	18-738	Screw -----	2
29	1003 L	Set Screw -----	2
30	14-399	Hinge Shaft -----	2
31	4186-16	Button Tray, complete, for Styles 200-1, -2, -6, -7, -8, -9, -10, -25, -26, -27 -----	1
32	16-297	Needle Bar Bushing, lower -----	1
33	16-411	Needle Bar Bushing, upper -----	1
34	4119-86	Thread Cutting Knife, complete, for Styles 200-10 -15 -----	1
35	22-255	Spring Pin, for Styles 200-10, -15 -----	2
36	21-96	Spring, for Styles 200-10, -15 -----	1
37	46-182	Thread Cutting Lever Link, bottom, for Styles 200-10, -15 -----	1
38	46-183	Thread Cutting Cam Link, for Styles 200-10, -15 -----	1
39	18-1035	Screw, for Styles 200-10, -15 -----	5
40	CS337	Screw, for Styles 200-10, -15 -----	2
41	46-181	Thread Cutting Lever Link, top, for Styles 200-10, -15 -----	1
42	45-426	Thread Cutting Knife Lever, for Styles 200-10, -15 --	1
43	75-267	Needle Bar Guard -----	1

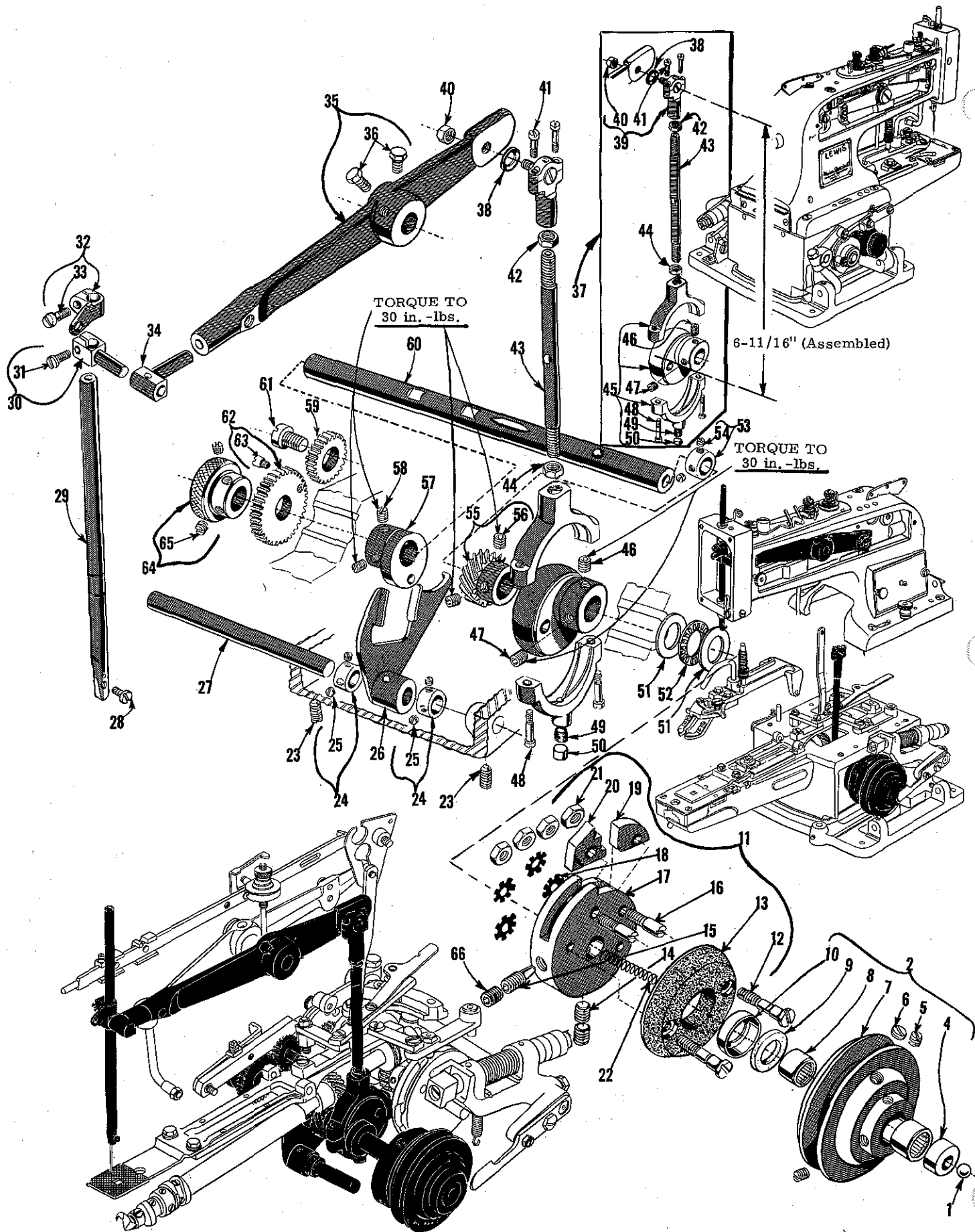

NEEDLE DRIVE, CLUTCH, STOP MOTION PARTS

Ref. No.	Part No.	Description	Amt. Req.
1	79-37	Ball-----	1
2	458-39	Pulley Assembly, complete-----	1
4	190-2 L	Pulley Insert-----	1
5	1005 L	Set Screw-----	2
6	18-800	Set Screw-----	1
7	58-39	Pulley-----	1
8	478-10	Needle Bearing-----	2
9	63-32	Grease Retaining Wick-----	1
10	40-169	Retaining Washer-----	1
11	444-334	Stop Disc, complete-----	1
12	18-982	Screw-----	2
13	44-288	Pulley Clutch Disc-----	1
14	18-967	Set Screw-----	1
15	18-958	Spot Screw-----	1
16	18-959	Screw-----	2
17	44-334	Stop Motion Disc-----	1
18	652 N-14	Eccentric Washer-----	4
19	51-20	Stop Motion Disc Latch-----	1
20	166-7	Stop Motion Disc Pawl-----	1
21	20-127	Nut-----	4
22	21-229	Spring-----	1
23	1003 L	Set Screw-----	2
24	CS462	Collar-----	2
25	1022 L	Set Screw-----	2
26	445-298	Lever Engaging Button Clamp Lifting Link-----	1
27	14-362	Lever Shaft-----	1
28	18-272	Screw-----	1
	*18-725	Set Screw, headless, for needle longer than our longest standard, or needle bar turned 180°-----	1
29	25-11	Needle Bar-----	1
30	117-40	Needle Bar Bearing Block Clamp-----	1
31	18-71	Screw-----	1
32	41-47	Needle Bar Thread Guide-----	1
33	18-907	Screw-----	1
34	117-39	Needle Bar Bearing Block-----	1
35	45-335 A	Needle Bar Lever-----	1
36	1333 L	Set Screw-----	2
37	447-105	Needle Bar Connecting Rod, complete-----	1
38	40-63	Washer-----	1
39	4124-50	Ball Joint, upper, complete-----	1
40	1009 L	Nut-----	1
41	18-391	Screw-----	2
42	20-80	Nut-----	1
43	71-74	Rod-----	1
44	20-81	Nut-----	1
45	4124-49	Ball Joint, lower, complete-----	1
46	18-968	Spot Screw-----	1
47	18-730	Set Screw-----	1
48	18-925	Screw-----	2
49	666-19	Oil Wick-----	1
50	137-19	Oil Wick Retainer-----	1
51	40-135	Washer-----	2
52	478-27	Needle Thrust Bearing-----	1
53	2339 F	Thrust Collar-----	1
54	98	Set Screw-----	2
55	27-169	Driving Gear, for looper shaft-----	1
56	18-996	Set Screw-----	2
57	433-139	Button Clamp Lifting Link Lever Driving Eccentric, complete-----	1
58	1005 L	Set Screw-----	2
59	27-171	Intermediate Spur Gear, for Styles 200-1, -2, -6, -7, -8, -9, -21, -22, -23, -24, -25, -27-----	1
60	14-363	Pulley Shaft-----	1
61	18-878	Screw, for Styles 200-1, -2, -6, -7, -8, -9, -21, -22, -23, -24, -25, -27-----	1
62	27-170	Spur Gear, for Styles 200-1, -2, -6, -7, -8, -9, -21, -22, -23, -24, -25, -27--	1
63	18-39	Screw-----	1
64	57-23	Handwheel-----	1
65	1025 L	Set Screw-----	2
66	18-967	Set Screw-----	2

\* Available as extra send and charge item.

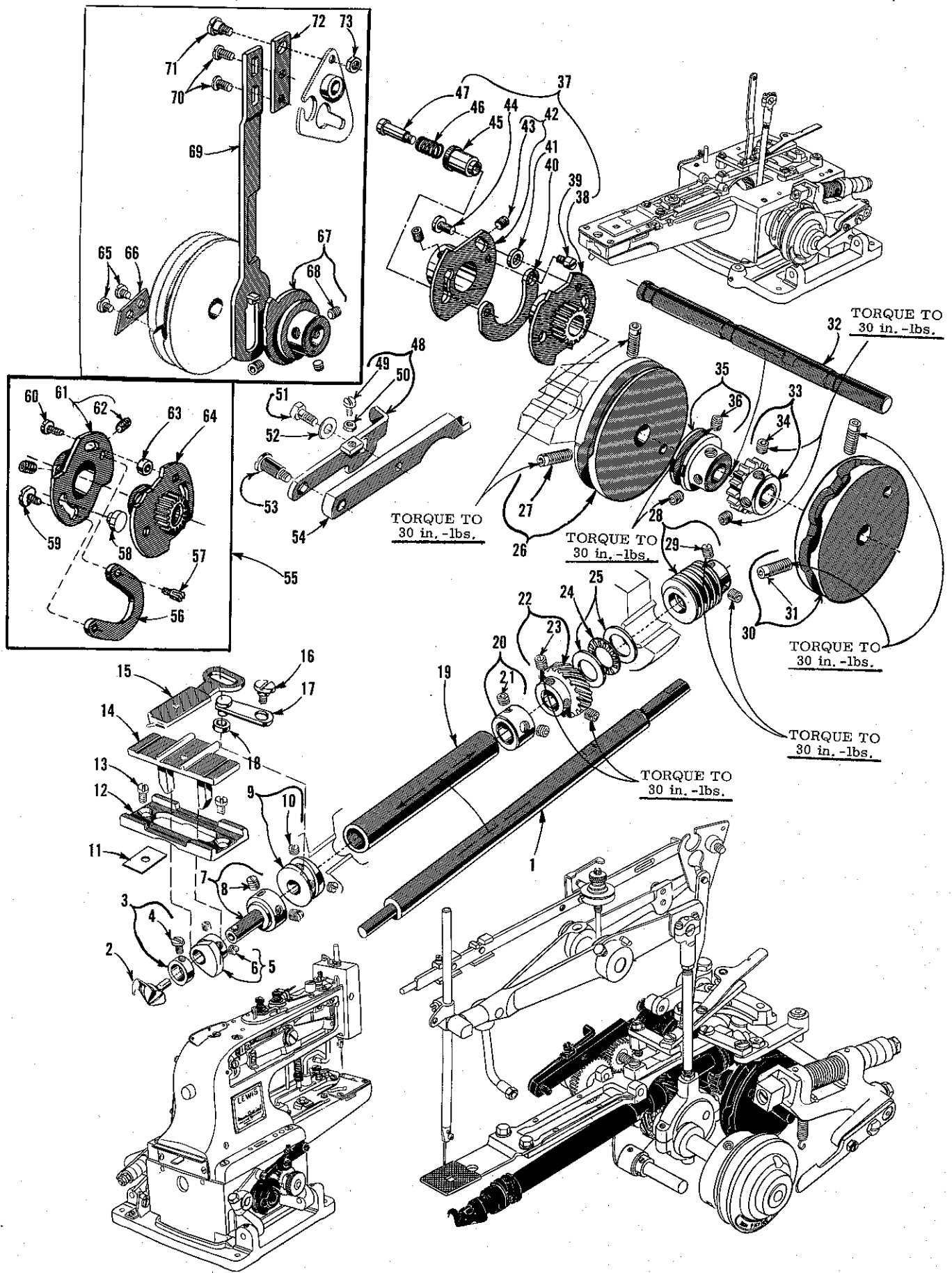

CAMS, LOOPER DRIVE STITCH SELECTING PARTS

Ref. No.	Part No.	Description	Amt. Req.
1	14-366	Looper Shaft -----	1
2	36-21	Looper -----	1
3	39-143	Collar -----	1
4	18-949	Looper Clamping Screw -----	1
5	434-40	Loop Positioning Finger Cam, complete -----	1
6	18-634	Screw -----	2
7	70-50	Cam and Looper Sleeve -----	1
8	1005 L	Set Screw -----	2
9	34-47	Loop Positioning Finger Cam -----	1
10	1029 L	Set Screw -----	2
11	164-39	Shim, .005 inch (.127 mm) thick -----As Req.	
	164-40	Shim, .010 inch (.254 mm) thick -----As Req.	
	164-41	Shim, .015 inch (.381 mm) thick -----As Req.	
12	190-3 L	Yoke Slide Insert -----	1
13	18-949	Screw -----	2
14	49-25	Positioning Finger Yoke Slide, for Styles 200-1, -2, -6, -7, -8, -9, -16, -17, -21, -22, -23, -24, -25, -26, -27 -----	1
	49-33	Positioning Finger Yoke Slide, for Styles 200-10, -15 -----	1
15	122-58	Loop Positioning Finger -----	1
16	18-934	Screw -----	1
17	445-349	Loop Positioning Finger Lever -----	1
18	35-20	Loop Positioning Finger Lever Roll -----	1
19	61-80	Looper Shaft Tube -----	1
20	39-131	Looper Shaft Collar -----	1
21	18-996	Set Screw -----	2
22	27-168	Looper Shaft Driven Gear -----	1
23	18-996	Set Screw -----	2
24	478-27	Needle Thrust Bearing -----	1
25	40-135	Washer -----	2
26		Cam, left side (See Chart Below) -----	1
27	18-984	Set Screw -----	2
28		Driving Gear, for camshaft (See Chart Below) -----	1
29	18-996	Set Screw -----	2
30		Cam, right side (See Chart Below) -----	1
31	18-984	Set Screw -----	2
32	14-364	Camshaft -----	1
33		Camshaft Driven Gear (See Chart Below) -----	1
34	18-996	Set Screw -----	2
35	39-107	Collar -----	1
36	18-730	Set Screw -----	2

37 thru 73

See following page

STYLE NO.	DET. 33 Driven	DET. 28 Driving
200-1	27-155	27-189
200-2	27-191	27-190
200-6	27-155	27-189
200-7	27-191	27-190
200-8	27-155	27-189
200-9	27-191	27-190
200-10	27-155	27-189
200-15	27-155	27-189
200-16	27-155	27-189
200-17	27-191	27-190
200-21	27-155	27-189
200-22	27-191	27-190
200-23	27-155	27-189
200-24	27-191	27-190
200-25	27-155	27-189
200-26	27-226	27-225
200-27	27-155	27-189

STYLE NO.	DET. 26 Left	DET. 30 Right
200-1	34-35	34-53
200-2	34-35	34-54
200-6	34-71	34-53
200-7	34-73	34-54
200-8	34-68	34-35
200-9	34-69	34-35
200-10	34-75	34-53
200-15	34-91	34-53
200-16	34-81	None
200-17	34-82	None
200-21	34-71	34-53
200-22	34-73	34-54
200-23	34-35	34-53
200-24	34-35	34-54
200-25	34-35	34-95
200-26	34-35	34-96
200-27	34-35	34-53

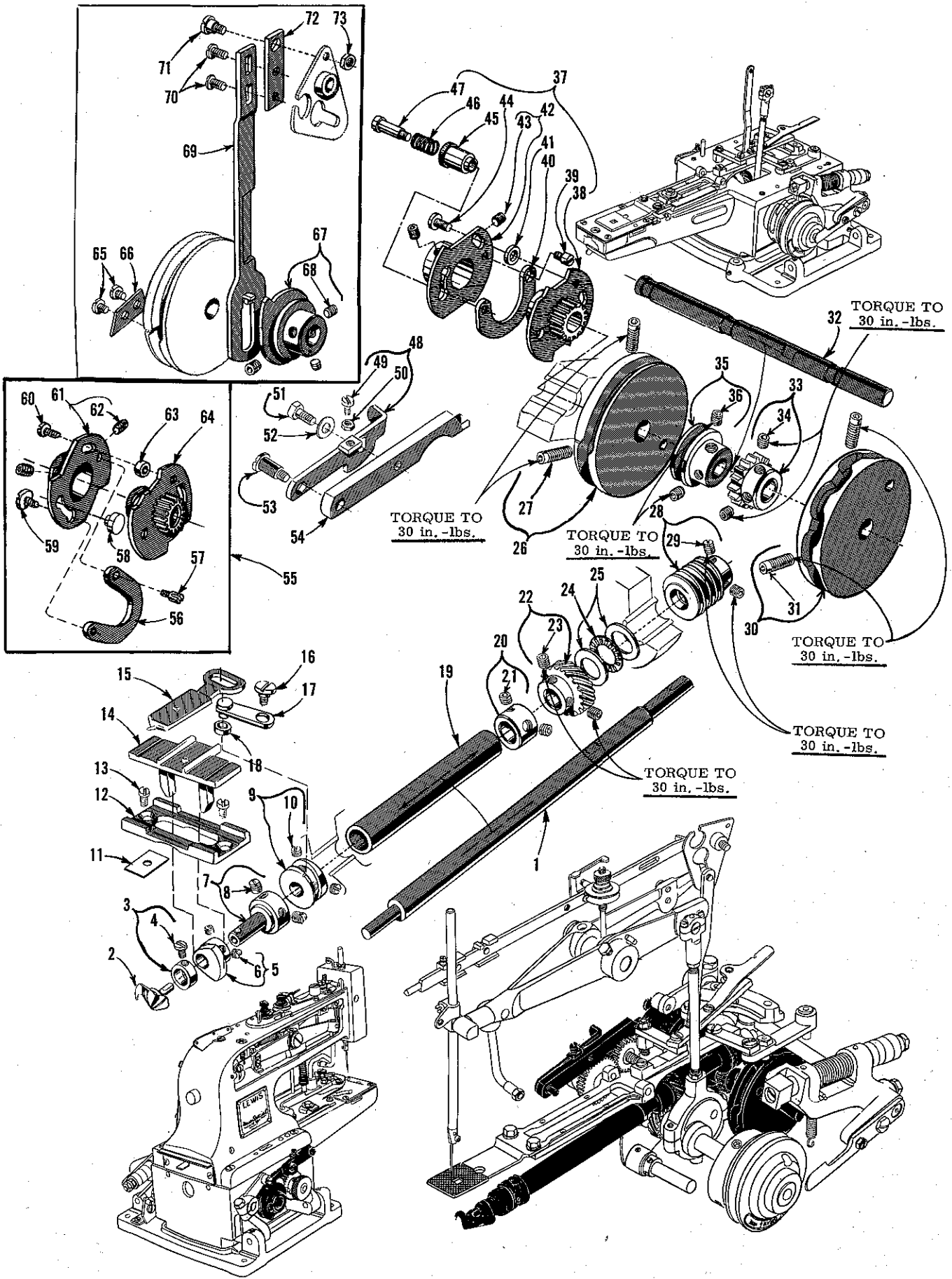



CAMS, LOOPER DRIVE, STITCH SELECTING PARTS

<u>Ref.</u> <u>No.</u>	<u>Part</u> <u>No.</u>	<u>Description</u>	<u>Amt.</u> <u>Req.</u>
1 thru 36		See preceding page	
37	434-104	Stop Motion Cam and Gear Assembly, complete with shoe and knob, for Styles 200-1, -2, -6, -7, -16, -21, -23, -24, -26, -27 -----	1
38	434-101	Cam and Gear Assembly, right -----	1
39	18-39	Screw -----	1
40	180-4	Cam Shoe -----	1
41	39-151	Collar, spacing -----	1
42	34-104	Cam, left -----	1
43	18-730	Screw -----	2
44	22585 A	Screw -----	1
45	142-6	Knob -----	1
46	21-322	Spring -----	1
47	18-835	Screw -----	1
48	51-22	Latch, for Styles 200-1, -2, -6, -7, -8, -9, -21, -22, -23, -24, -25, -27 -----	1
49	1170 L	Screw -----	1
50	1311 L	Nut -----	1
51	18-629	Screw, for Styles 200-1, -2, -6, -7, -8, -9, -21, -22, -23, -24, -25, -27 -----	1
52	40-38	Washer, for Styles 200-1, -2, -6, -7, -8, -9, -21, -22, -23, -24, -25, -27 -----	1
53	18-619	Screw, for Styles 200-1, -2, -6, -7, -8, -9, -21, -22, -23, -24, -25, -27 -----	1
54	45-331	Lever, for Styles 200-1, -2, -6, -7, -8, -9, -21, -22, -23, -24, -25, -27 -----	1
55	434-102	Stop Motion Cam and Gear Assembly, complete with shoe for Styles 200-8, -9, -10, -15, -17, -22, -25 -----	1
56	180-4	Cam Shoe -----	1
57	18-39	Screw -----	1
58	89-65	Filling Plug -----	1
59	18-1112	Screw -----	1
60	22585 A	Screw -----	1
61	34-104	Cam, left -----	1
62	18-730	Screw -----	2
63	39-151	Collar, spacing -----	1
64	434-101	Cam and Gear Assembly, right -----	1
65	CS337	Screw, for Style 200-10, -15 -----	2
66	166-11	Thread Cutter Operating Pawl, for Styles 200-10, -15 -----	1
67	34-65	Nipper Bar Operating Cam, for Style 200-10 -----	1
68	18-996	Set Screw -----	3
69	46-168	Nipper Bar Operating Link, lower, for Style 200-10 -----	1
70	18-330	Screw, for Style 200-10 -----	2
71	861 L	Screw, for Style 200-10 -----	1
72	46-169	Nipper Bar Operating Link, upper, for Style 200-10 -----	1
73	1160 L	Nut, for Style 200-10 -----	1

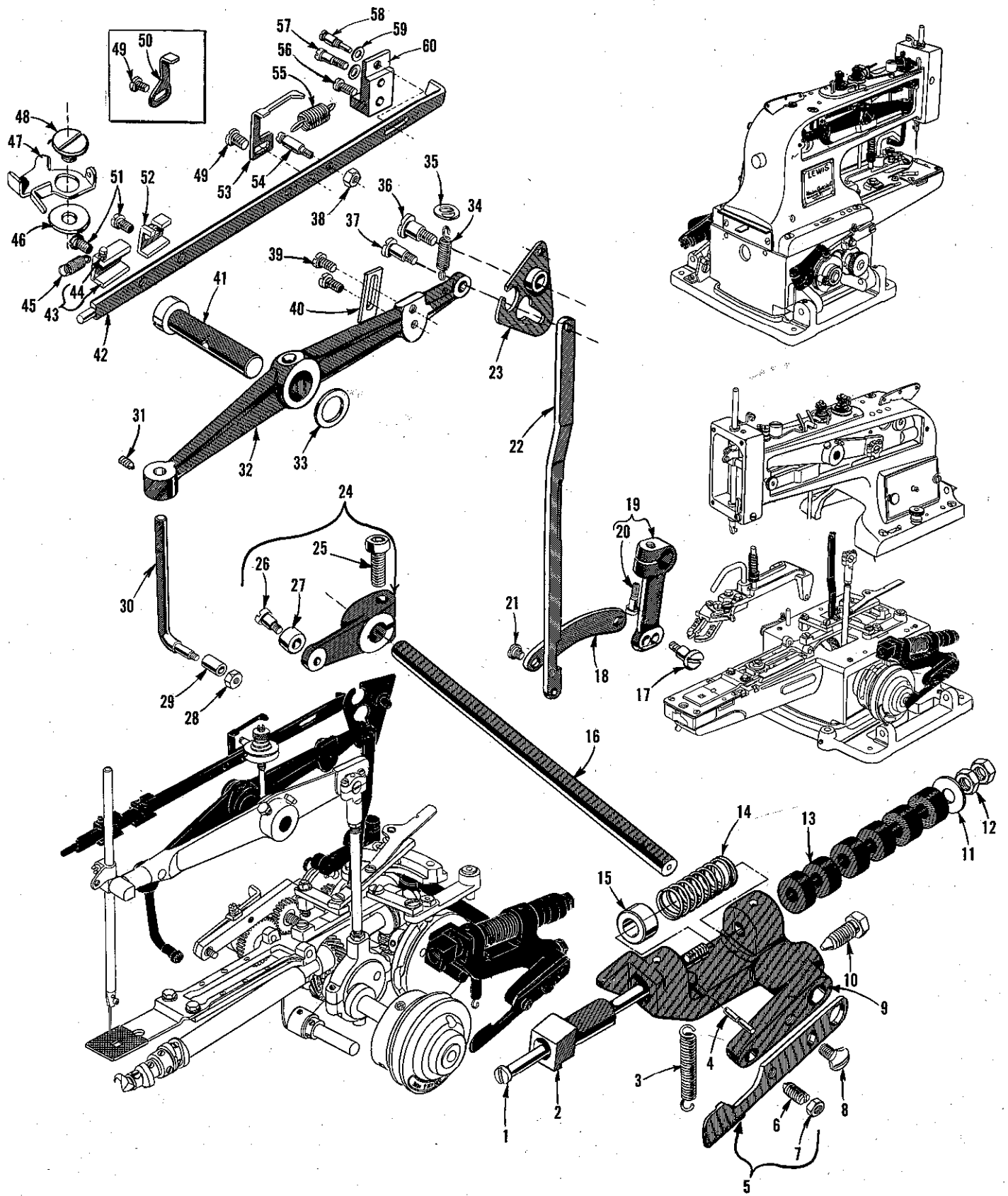

BUTTON CLAMP LIFTER, STOP MOTION, NIPPER PARTS

<u>Ref. No.</u>	<u>Part No.</u>	<u>Description</u>	<u>Amt. Req.</u>
1	71-92	Stop Motion Plunger Rod -----	1
2	26-163	Stop Motion Plunger -----	1
3	21-360	Stop Motion Lever Restoring Spring -----	1
4	22-266	Stop Motion Lever Restoring Spring Pin -----	1
5	45-490	Lever for Applying Pressure on Stop Motion Disc -----	1
6	18-747	Spot Screw -----	1
7	20-34	Nut -----	1
8	18-280	Screw -----	1
9	45-348	Stop Motion Plunger Lever -----	1
10	18-819	Screw -----	1
11	652-16	Washer -----	1
12	20-128	Nut -----	2
13	40-198	Washer -----	6
14	21-457	Spring -----	1
15	157-13	Spacer Collar -----	1
16	14-365	Stop Motion Lever Shaft for Styles 200-1, -2, -6, -7, -8, -9, -16, -17, -21, -22, -23, -24, -25, -26, -27 -----	1
	14-488	Stop Motion Lever Shaft for Styles 200-10, -15 -----	1
17	18-392	Screw -----	1
18	46-135	Link for Styles 200-1, -2, -8, -9, -15, -16, -17, -23, -24, -25, -26, -27 -----	1
	46-175	Link for Styles 200-6, -7, -10, -21, -22 -----	1
19	445-286	Lever, complete, engaging button clamp lifting link -----	1
20	22653 B-10	Clamp Screw -----	1
21	18-809	Screw -----	1
22	46-162	Button Clamp Lifting Link -----	1
23	445-405	Nipper Bar Actuating Lever -----	1
24	445-370	Stop Motion Tripping Lever -----	1
25	22653 E-14	Clamp Screw -----	1
26	CS303-1/2	Screw -----	1
27	35-16	Stop Motion Tripping Lever Cam Roll -----	1
28	835 L	Nut -----	1
29	35-17	Button Clamp Lifting Rod Roll -----	1
30	71-124	Button Clamp Lifting Rod -----	1
31	22651 ED-6	Set Screw -----	1
32	45-503	Button Clamp Lifting Lever -----	1
33	40-143	Washer -----	1
34	21-96	Spring -----	1
35	40-168	Washer -----	1
36	18-562	Screw -----	1
37	18-619	Screw -----	1
38	835 L	Nut -----	1
39	18-732	Screw -----	2
40	42-34	Button Clamp Lifting Lever Stop -----	1
41	14-368	Button Clamp Lifting Lever Shaft -----	1
42	138-15	Nipper Bar -----	1
43	4115-104	Nipper Bar Block, complete -----	1
44	22-235	Spring Pin -----	1
45	21-366	Spring -----	1
46	60038 K	Washer -----	1
47	4187-3	Thread Nipper -----	1
48	18-1088	Screw -----	1
49	18-745	Screw -----	1
50	45-404	Automatic Tension Opening Lever for Style 200-10 -----	1
51	18-745	Screw -----	2
52	115-106	Nipper Bar Block -----	1
53	45-327	Thread Tension Release Lever -----	1
54	18-827	Spring Screw -----	1
55	21-379	Nipper Bar Spring -----	1
56	1158 L	Screw -----	1
57	1206 L	Screw -----	1
58	18-826	Screw -----	1
59	1185 L	Washer -----	2
60	115-175	Nipper Bar Bearing Block -----	1

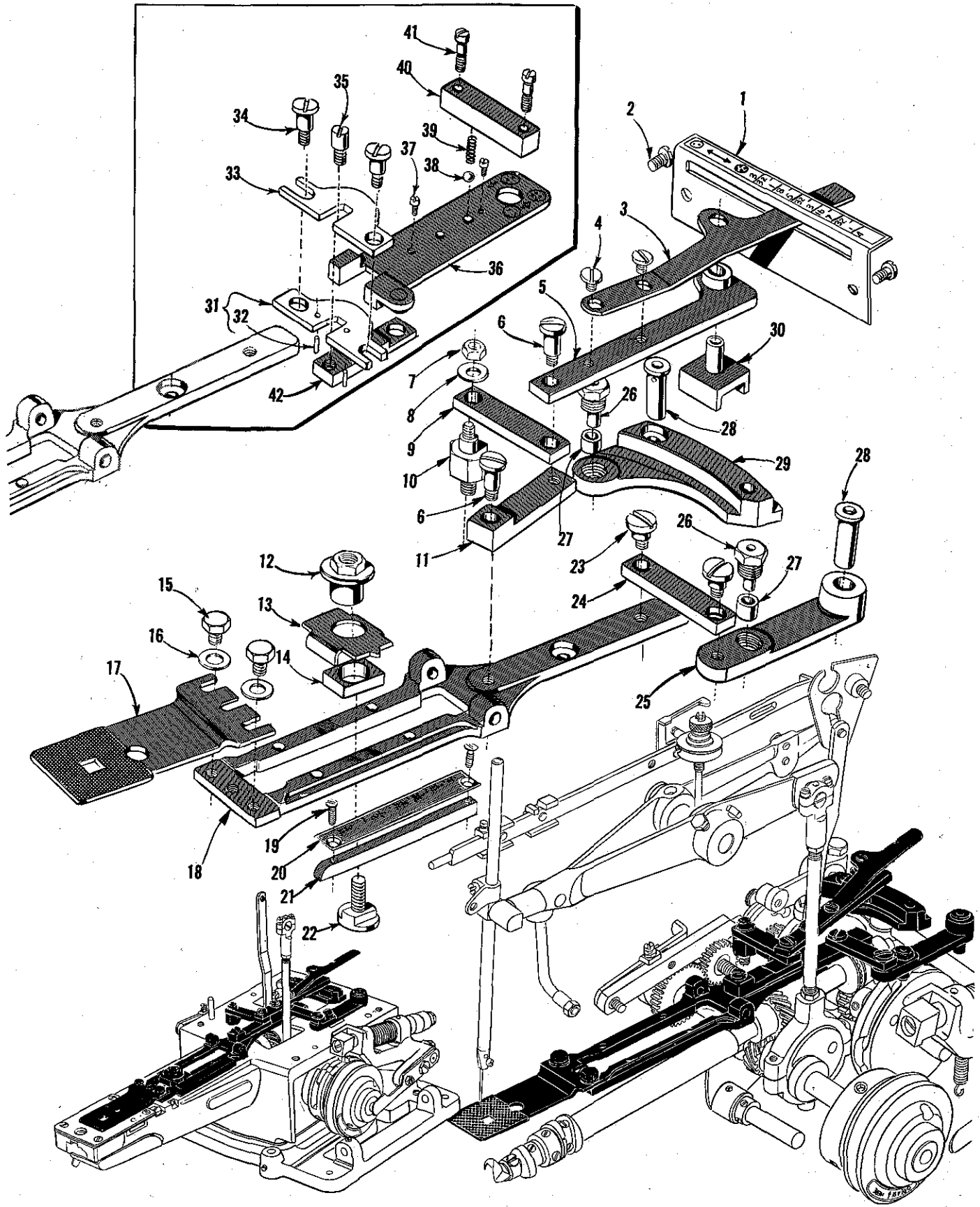

FEED PLATE AND BUTTON CLAMP POSITIONING PARTS

<u>Ref. No.</u>	<u>Part No.</u>	<u>Description</u>	<u>Amt. Req.</u>
1	110-206	Graduated Plate for Styles 200-1, -2, -10, -15, -23, -24, -25, -26, -27 -----	1
	110-318	Graduated Plate for Styles 200-8, -9, -16, -17-----	1
	110-328	Graduated Plate for Styles 200-6, -7, -21, -22 -----	1
2	18-330	Screw -----	2
3	21-287	Handle and Indicator Spring-----	1
4	CS337	Screw -----	2
5	446-136	Link-----	1
6	18-619	Screw -----	2
7	1160 L	Nut-----	1
8	40-38	Washer -----	1
9	46-137	Link-----	1
10	17-124	Stud-----	1
11	46-138	Link-----	1
12	20-109	Nut for Styles 200-1, -2, -6, -7, -8, -9, -10, -15, -21, -22, -23, -24, -25, -26, -27-----	1
	20-109	Nut for Styles 200-16, -17-----	2
13	155-14	Indicator for Styles 200-1, -2, -6, -7, -8, -9, -10, -15, -21, -22, -23, -24, -25, -26, -27-----	1
	155-14	Indicator for Styles 200-16, -17-----	2
14	69-17	Bearing Block for Styles 200-1, -2, -6, -7, -8, -9, -10, -15, -21, -22, -23, -24, -25, -26, -27-----	1
	69-17	Bearing Block for Styles 200-16, -17-----	2
15	18-626	Screw for Styles 200-1, -2, -6, -7, -8, -9, -10, -15, -21, -22, -23, -24, -25, -26, -27-----	2
16	40-38	Washer for Styles 200-1, -2, -6, -7, -8, -9, -10, -15, -21, -22, -23, -24, -25, -26, -27-----	2
17	24-338	Feed Plate for Styles 200-1, -2, -6, -7, -8, -9, -10, -15, -23, -24, -25, -26-----	1
	24-281	Feed Plate, for Style 200-27-----	1
18	158-29	Slide Plate for Styles 200-1, -2, -10, -15, -23, -24, -25, -26, -27-----	1
	158-17	Slide Plate for Styles 200-16, -17-----	1
	158-19	Slide Plate for Styles 200-6, -7, -8, -9, -21, -22-----	1
19	18-966	Screw for Styles 200-1, -2, -6, -7, -8, -9, -10, -15, -21, -22, -23, -24, -25, -26, -27-----	2
20	110-205	Graduated Plate for Styles 200-1, -2, -6, -7, -8, -9, -10, -15, -21, -22, -23, -24, -25, -26, -27-----	1
21	115-108	Block for Styles 200-1, -2, -6, -7, -8, -9, -10, -15, -21, -22, -23, -24, -25, -26, -27-----	1
22	18-818	Screw for Styles 200-1, -2, -6, -7, -8, -9, -10, -15, -21, -22, -23, -24, -25, -26, -27-----	1
	18-818	Screw for Styles 200-16, -17-----	2
23	18-392	Screw for Styles 200-1, -2, -10, -15, -23, -24, -25, -26, -27-----	2
24	46-137	Link for Styles 200-1, -2, -10, -15, -23, -24, -25, -26, -27-----	1
25	45-290	Lever for Styles 200-1, -2, -6, -7, -8, -9, -10, -15, -21, -22, -23, -24, -25, -26, -27-----	1
26	18-814	Screw for Styles 200-1, -2, -6, -7, -8, -9, -10, -15, -21, -22, -23, -24, -25, -26, -27-----	2
	18-814	Screw for Styles 200-16, -17-----	1
27	35-15	Cam Roll for Styles 200-1, -2, -6, -7, -8, -9, -10, -15, -21, -22, -23, -24, -25, -26, -27-----	2
	35-15	Cam Roll for Styles 200-16, -17-----	1
28	22-219	Pin for Styles 200-1, -2, -6, -7, -8, -9, -10, -15, -21, -22, -23, -24, -25, -26, -27-----	2
	22-219	Pin for Styles 200-16, -17-----	1
29	45-288	Lever for Styles 200-1, -2, -15, -16, -17, -23, -24, -25, -26, -27-----	1
	45-416	Lever for Styles 200-6, -7, -8, -9, -10, -21, -22-----	1
30	69-16	Slide Block-----	1
31	446-173	Bottom Link, complete, for Styles 200-6, -7, -8, -9, -21, -22-----	1
32	22-C214-13	Pin-----	2
33	46-173	Top Link for Styles 200-6, -7, -8, -9, -21, -22-----	1
34	18-1023	Screw for Styles 200-6, -7, -8, -9, -21, -22-----	2
35	18-1022	Screw for Styles 200-6, -7, -8, -9, -21, -22-----	1
36	4110-329	Slide Plate for Styles 200-6, -7, -21, -22-----	1
	4110-317	Slide Plate for Styles 200-8, -9-----	1
37	1036 L	Stop Screw for Styles 200-6, -7, -8, -9, -21, -22-----	2
38	79-31	Ball for Styles 200-6, -7, -8, -9, -21, -22-----	1
39	21-300	Spring for Styles 200-6, -7, -8, -9, -21, -22-----	1
40	115-137	Block for Styles 200-6, -7, -8, -9, -21, -22-----	1
41	18-766	Screw for Styles 200-6, -7, -8, -9, -21, -22-----	2
42	46-174	Link for Styles 200-6, -7, -8, -9, -21, -22-----	1

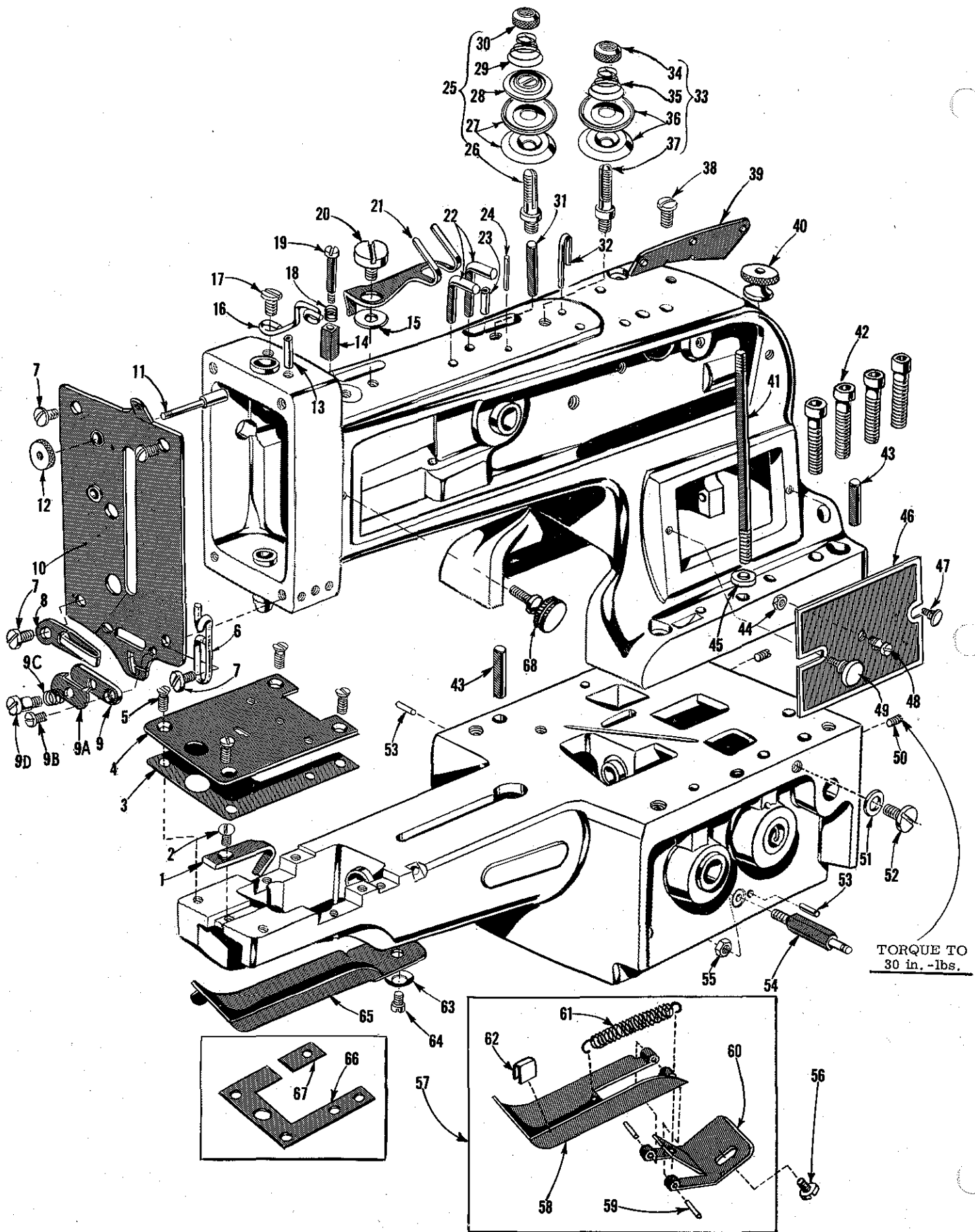

MISCELLANEOUS PLATES, THREAD HANDLING PARTS

Ref. No.	Part No.	Description	Amt. Req.
1	8-111	Needle Guard-----	1
2	18-750	Screw-----	1
3	110-213	Spacer Plate, for Styles 200-1, -2, -6, -7, -8, -9, -16, -17, -21, -22, -23, -24, -25, -26, -27-----	1
4	110-302	Needle Plate, for Styles 200-1, -2, -10, -15, -16, -17, -23, -24, -25, -26, -27-----	1
	110-304	Needle Plate, for Styles 200-6, -7, -8, -9, -21, -22-----	1
5	18-920	Screw-----	4
6	51758	Thread Guide-----	1
7	18-786	Screw-----	2
8	62271 C	Thread Guide-----	1
9	99-345	Needle Thread Nipper Holder-----	1
9A	57 WB	Needle Thread Nipper Spring Plate-----	1
9B	18-1077	Screw-----	1
9C	21-381	Spring-----	1
9D	18-1076	Screw-----	1
10	432-263	Machine Arm Front Cover-----	1
11	26-147	Nipper Releasing Plunger-----	1
12	20-98	Knurled Thumb Nut-----	1
13	61-33	Oil Tube-----	1
14	115-107	Nipper Block-----	1
15	40-188	Washer-----	1
16	41-49	Thread Guide-----	1
17	18-997	Screw-----	1
18	21-310	Spring-----	1
19	18-854	Screw-----	1
20	18-1088	Bearing Screw-----	1
21	45-434	Thread Pull-off Lever-----	1
22	41-41	Thread Guide-----	2
23	61-32	Oil Tube-----	1
24	22-195	Tension Disc Pin-----	1
25	468-21	Thread Nipper Staff, complete-----	1
26	68-21	Nipper Staff-----	1
27	1183 L	Tension Disc-----	2
28	61292 H	Tension Lifting Washer-----	1
29	21-284	Tension Spring-----	1
30	20-60	Adjusting Nut-----	1
31	22-221	Tension Release Pin-----	1
32	41-53	Thread Guide-----	1
33	468-22	Thread Tension Staff, complete-----	1
34	20-60	Adjusting Nut-----	1
35	21-414	Tension Spring-----	1
36	1183 L	Tension Disc-----	2
37	68-22	Tension Staff-----	1
38	18-997	Screw-----	1
39	61470 D	Thread Guide-----	1
40	1316 L	Knurled Nut-----	1
41	18-816	Screw Stud-----	1
42	22652 E-20	Screw-----	4
43	22-175	Pin-----	2
44	1160 L	Nut-----	1
45	40-170	Washer-----	1
46	32-198	Cover-----	1
47	SB79	Screw-----	1
48	18-752	Knob Screw-----	1
49	18-286	Screw-----	1
50	18-547	Set Screw-----	2
51	21657 E	Washer-----	1
52	22548	Screw-----	1
53	22-238	Timing Pin-----	2
54	22-251	Spring Pin-----	1
55	CS231	Nut-----	1
56	888 L	Screw, for Styles 200-23 and -24-----	1
57	432-303	Hinged Cover Assembly, for Styles 200-23 and -24-----	1
58	32-303	Swinging Cover-----	1
59	22-206	Pin-----	2
60	50-295	Swinging Cover Bracket-----	1
61	21-343	Spring-----	1
62	144-31	Isolator-----	1
63	1221 L	Spring Washer, for all Styles except 200-23 and -24-----	1
64	18-934	Screw, for all Styles except 200-23 and -24-----	1
65	32-209	Machine Base Swing Cover, for all Styles except 200-23 and -24-----	1
66	110-333	Spacer Plate, large, for Styles 200-10, -15-----	1
67	110-334	Spacer Plate, small, for Styles 200-10, -15-----	1
68	18-1047	Thumbscrew, for arm covers-----	2

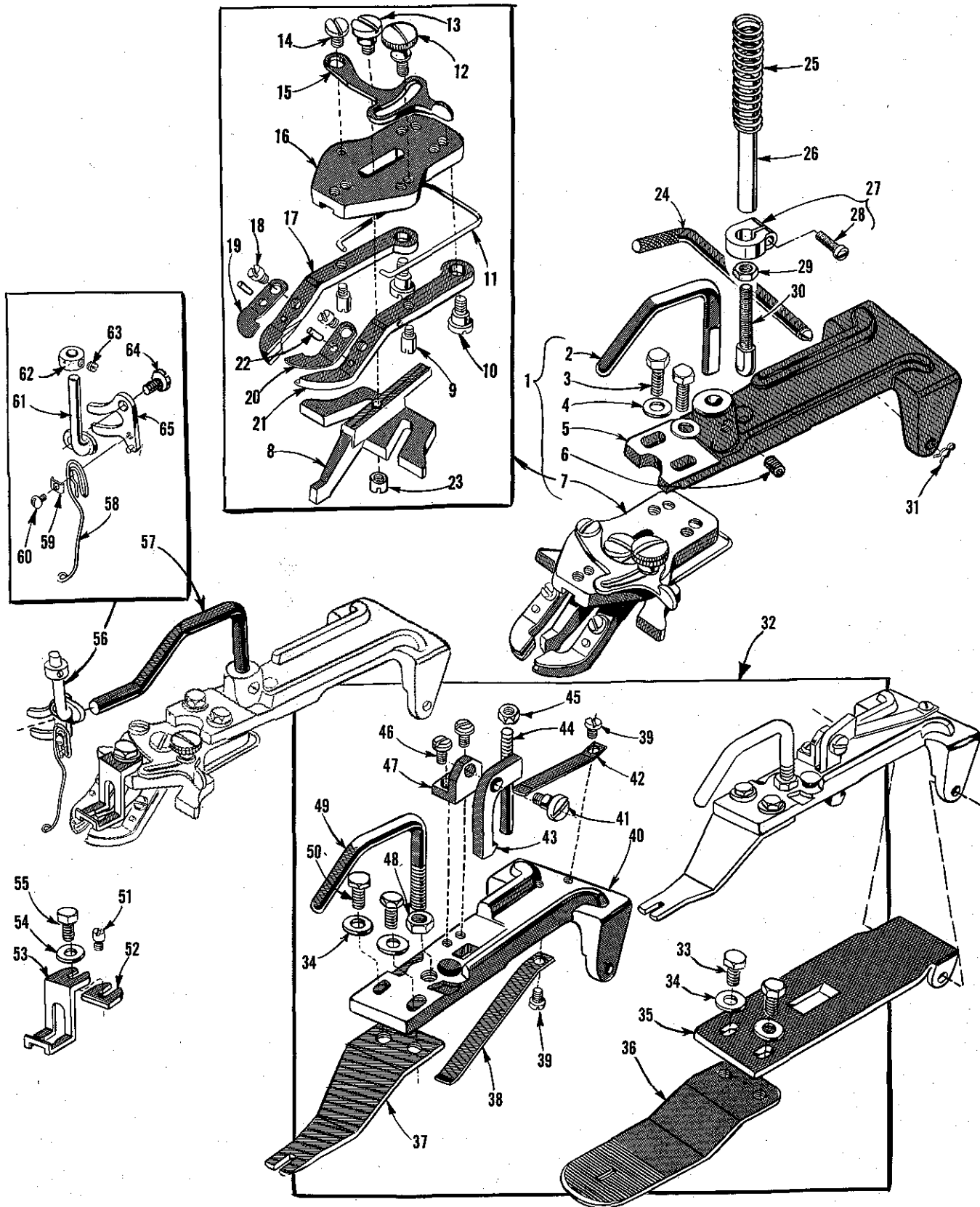



STANDARD BUTTON AND TACKING CLAMPS

<u>Ref. No.</u>	<u>Part No.</u>	<u>Description</u>	<u>Amt. Req.</u>
1	430-63-6	Button Clamp, complete with holder, for Styles 200-1, -2, -6, -7, -8, -9, -25, -26	1
2	71-112	Button Clamp Lifting Rod, also for Styles 200-15, -21, -22, -23, -24, -27	1
3	18-873	Screw, also for Styles 200-10, -15	2
4	40-38	Washer, also for Styles 200-10, -15	2
5	99-270	Button Clamp Holder, also for Styles 200-10, -15, -21, -22	1
	99-344	Button Clamp Holder, for Styles 200-23, -24	1
6	18-1087	Set Screw, also for Styles 200-10, -15, -21, -22, -23, -24	1
7	*430-63	Button Clamp, for 14 to 45 ligne flat buttons, also for Styles 200-10, -15	1
8	**158-11	Slide	1
9	18-930	Bearing Screw	2
10	18-929	Hinge Screw	2
11	21-315	Spring	1
12	18-945	Clamp Screw	1
13	18-931	Screw	1
14	18-75	Hinge Screw	1
15	45-332	Stop Lever	1
16	99-316	Button Clamp Lever Jaw Holder	1
17	45-347	Button Clamp Lever Jaw, left	1
18	1189 L	Screw	2
19	#21-337	Button Holding Spring, left, for buttons up to 1/8 inch thick	1
20	#21-336	Button Holding Spring, right, for buttons up to 1/8 inch thick	1
21	45-346	Button Clamp Lever Jaw, right	1
22	22-205	Locating Pin	2
23	20-123	Nut	1
24	22-224	Hinge Pin	1
25	21-317	Spring	1
26	22-347	Stop Pin	1
27	439-153	Collar	1
28	18-375	Screw	1
29	12538	Nut	1
30	18-1128	Screw	1
31	21-407	Spring Clip	1
32	430-88	Tacking Clamp, complete with holder, for Styles 200-16, -17	1
33	18-970	Screw	2
34	40-38	Washer	4
35	99-326	Holder, lower	1
36	30-89	Clamp, lower	1
37	30-88	Clamp, upper	1
38	21-399	Spring, lower	1
39	18-623	Screw	2
40	99-328	Holder, upper	1
41	18-963	Screw	1
42	21-398	Spring, upper	1
43	166-10	Pawl	1
44	22-289	Stop Pin	1
45	1160 L	Nut	1
46	18-596	Screw	2
47	50-247	Bracket	1
48	20-45	Nut	1
49	71-97	Rod	1
50	18-677	Screw	2
51	18-1010	Stop Screw, for Style 200-10	1
52	157-8	Thread Pulling Separator Spacer, for Style 200-10	1
53	182-16	Thread Pulling Separator, for Style 200-10	1
54	40-38	Washer, for Style 200-10	1
55	18-970	Screw, for Style 200-10	1
56	445-432	Thread Wiper Lever Assembly, for Style 200-10	1
57	71-114	Rod	1
58	21-411	Thread Wiper Spring	1
59	52958 H	Spring Clamp	1
60	18-1036	Screw	1
61	68-29	Staff	1
62	39-C255	Collar	1
63	18-C186	Set Screw	1
64	1776 L	Screw	1

\*NOTE: For 30 to 60 ligne flat buttons, order 430-63-1.

\*\*NOTE: For 30 to 60 ligne flat buttons, order 158-15.

#NOTE: For sewing thick buttons requiring up to an additional 11/64 inch in height, order No. 21-393 Button Holding Spring, left and No. 21-392 Button Holding Spring, right, as an extra send and charge item.

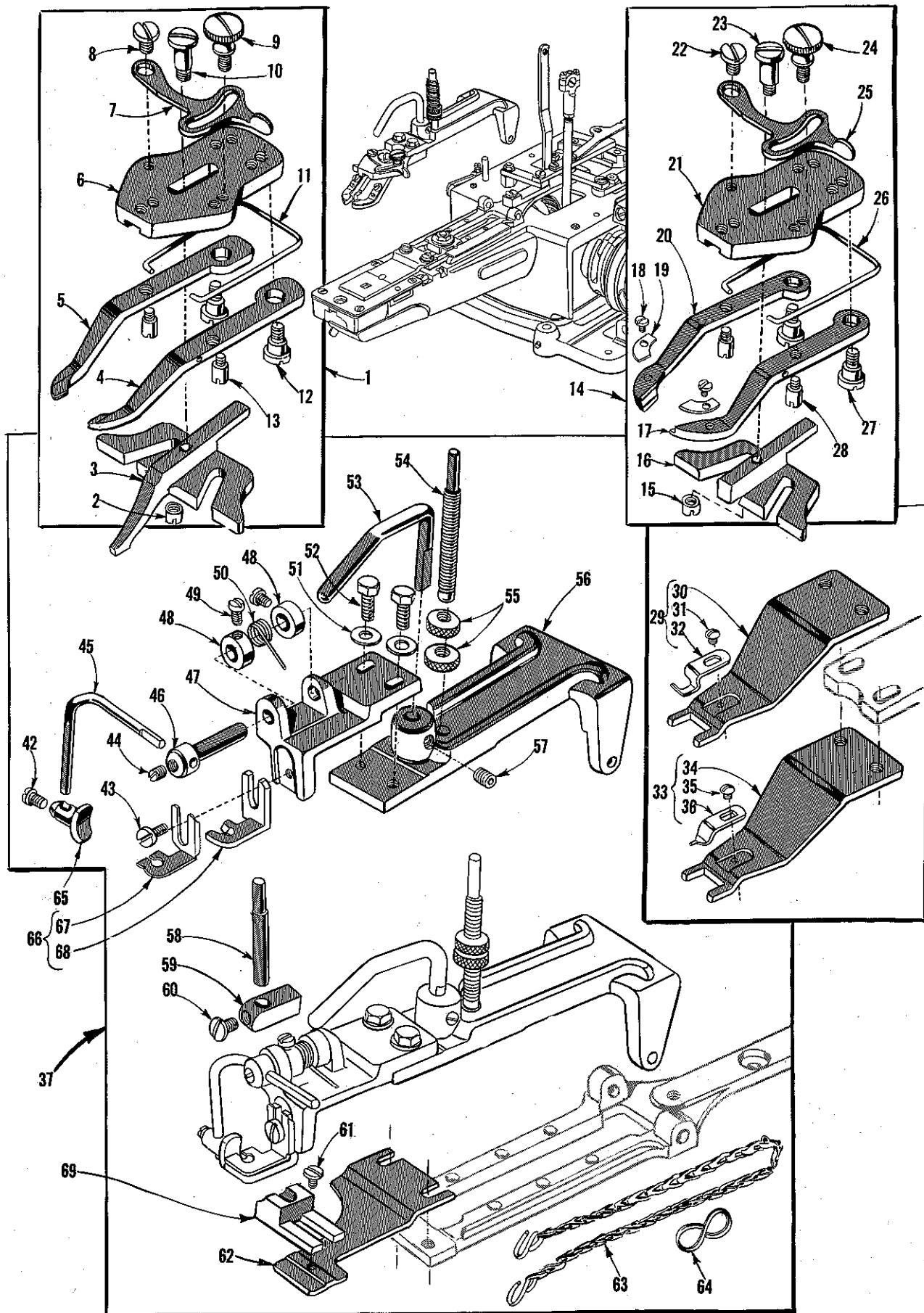

\*EXTRA ATTACHMENTS AVAILABLE FOR CLASS 200

<u>Ref. No.</u>	<u>Part No.</u>	<u>Description</u>	<u>Amt. Req.</u>
1	430-77	Snap Fastener Clamp, complete, for Styles 200-1, -2, -6, -7, -8 -9, -10, -15-----	1
2	20-123	Nut-----	1
3	158-21	Slide-----	1
4	45-472	Jaw Lever, right-----	1
5	45-471	Jaw Lever, left-----	1
6	99-316-1	Lever Holder-----	1
7	45-332	Stop Lever-----	1
8	18-75	Hinge Screw-----	1
9	18-945	Clamp Screw-----	1
10	18-931	Screw-----	1
11	21-315	Spring-----	1
12	18-929	Hinge Screw-----	2
13	18-930	Bearing Screw-----	2
14	430-86	Hook and Eye Clamp, complete, for Styles 200-1, -2, -6, -7, -8, -9, -10, -15-----	1
15	20-123	Nut-----	1
16	158-25	Slide-----	1
17	45-459	Lever, right-----	1
18	18-125	Screw-----	2
19	110-404	Lever Plate-----	2
20	45-458	Lever, left-----	1
21	99-316-1	Lever Holder-----	1
22	18-75	Hinge Screw-----	1
23	18-931	Screw-----	1
24	18-945	Clamp Screw-----	1
25	45-332	Stop Lever-----	1
26	21-315	Spring-----	1
27	18-929	Hinge Screw-----	2
28	18-930	Bearing Screw-----	2
29	430-75-1	Tacking Clamp, complete, for Styles 200-6, -7, -8, -9-----	1
30	30-75	Clamp-----	1
31	18-318	Screw-----	1
32	122-46	Thread Breaking Finger-----	1
33	430-75	Tacking Clamp, complete, for Styles 200-1, -2, -10, -15-----	1
34	30-75	Clamp-----	1
35	18-318	Screw-----	1
36	122-45	Thread Breaking Finger-----	1
37	*** 430-57-12	Shank Button Clamp, complete, with foot treadle, with chain, "S" hooks, but without clamp, adaptor, or work support block, for Styles 200-1, -2, -6, -7, -10, -15 (foot treadle No. 4135-9 not shown)-----	1
42	18-733	Screw-----	1
43	CS327	Screw-----	1
44	SB15	Screw-----	1
45	45-372	Lever-----	1
46	14-455	Lever Holding Shaft-----	1
47	50-238	Bracket-----	1
48	39-95	Collar-----	2
49	18-623	Screw-----	2
50	21-353	Spring-----	1
51	40-38	Washer-----	2
52	18-873	Screw-----	2
53	71-112	Rod-----	1
54	18-965	Screw-----	1
55	20-60	Knurled Nut-----	2
56	99-308	Button Clamp Holder-----	1
57	18-1087	Set Screw-----	1
58	17-155	Stud-----	1
59	115-127	Block-----	1
60	18-750	Screw-----	1
61	18-307	Screw-----	1
62	24-281	Feed Plate-----	1
63	130-9	Chain-----	1
64	131-C163-1	"S" Hook-----	1
65	** 430-55	Shank Button Holding Clamp for Styles 200-1, -2, -6, -7, -15-----	1
66	** 490-49	Shank Button Adapter, adjustable, for Styles 200-1, -2, -6, -7, -15-----	1
67	8-132	Guard, adjustable-----	1
68	90-49	Adapter-----	1
69	** 115-151	Shank Button Work Support Block for Styles 200-1, -2, -6, -7, -15-----	1

\* Machines on which attachments can be used are indicated in parts descriptions.

\*\* Due to the many varieties of shank buttons, this combination of holding clamp, adapter, and work support block is illustrated only to show their positions in the machine. In order to secure the proper combination of parts, a sample button must be submitted.

\*\*\* When used for buttons greater than 45 ligne, also order needle plate No. 110-204 as an extra send and charge item.

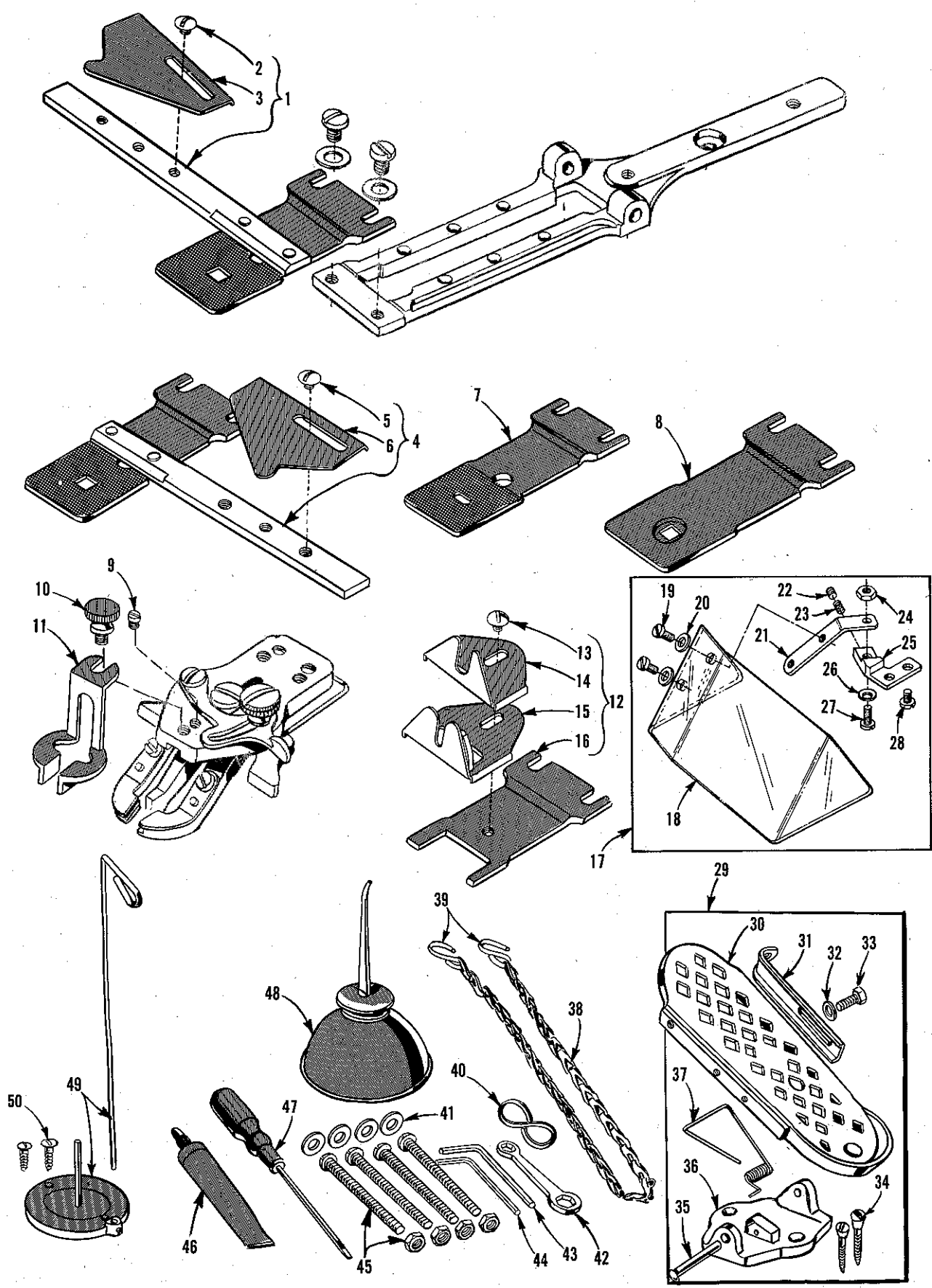

STANDARD ACCESSORIES FURNISHED WITH MACHINES IN CLASS 200  
\*EXTRA ATTACHMENTS AVAILABLE

Ref. No.	Part No.	Description	Amt. Req.
1	407-10	Button Spacing Gauge, complete, left side, for Styles 200-1, -2, -6, -7, -8, -9, -10, -15, -23, -24	1
2	18-974	Screw	1
3	7-10	Gauge	1
4	407-11	Button Spacing Gauge, complete, right side, for Styles 200-1, -2, -6, -7, -8, -9, -10, -15, -23, -24	1
5	18-974	Screw	1
6	7-11	Gauge	1
7	24-304	Feed Plate, for sewing sideways on two hole buttons, for Styles 200-1, -2, -6, -7, -10, -15, -23, -24	1
8	99-313-18	Holder, for 18 ligne stay buttons, for Styles 200-1, -2, -6, -7, -8, -9, -10, -15	1
	99-313-17	Holder, for 17 ligne stay buttons	1
	99-313-19	Holder, for 19 ligne stay buttons	1
	99-313-20	Holder, for 20 ligne stay buttons	1
	99-313-22	Holder, for 22 ligne stay buttons	1
	99-313-23	Holder, for 23 ligne stay buttons	1
	99-313-24	Holder, for 24 ligne stay buttons	1
9	18-987	Screw	1
10	18-986	Clamping Screw	1
11	5-525-11/32	Shanking Foot, for sewing 11/32 inch from garment, for Styles 200-1, -2, -6, -7, -8, -9, -10, -15	1
	5-525-1/8	Shanking Foot, for sewing 1/8 inch from garment	1
12	424-299	Button Necking Attachment, complete with feed plate, for Styles 200-1, -2, -6, -7, -10, -15	1
13	18-974	Screw	1
14	182-15	Separator	1
15	475-231	Guide	1
16	24-299	Feed Plate	1
17	408-147	Sewing Guard (complete)	1
18	8-147	Plastic Guard	1
19	22768 B	Screw	2
20	41358	Washer	2
21	45-498	Lever	1
22	22894 P	Screw	1
23	21-449	Spring	1
24	12934 A	Nut	1
25	115-171	Mounting Block, marked "A"	1
26	40-101	Washer, spring	1
27	22757	Screw	1
28	18-750	Screw, mounting	1
29	4135-9	Foot Treadle, complete	1
30	135-9	Foot Treadle, main section	1
31	45-424	Lever	1
32	40-181	Washer	1
33	18-1033	Screw	1
34	1504 L	Wood Screw	2
35	43-27	Rivet	1
36	50-265	Bracket	1
37	21-408	Spring	1
38	421 D-34	Chain	1
39	660-264	"S" Hook	2
40	131-C163-1	"S" Hook	1
41	652-16	Washer	4
42	59-6	Double End Wrench, 5/16 and 7/16 hex.	1
43	WR56	Allen Wrench, for 1/8 inch hex.	1
44	WR57	Allen Wrench, for 5/32 inch hex.	1
45	650-14	Stove Bolt	4
46	28604 P	Grease Tube	1
47	21201	Screwdriver, 1/4 inch blade, 7 inch over all	1
48	413 D	Oil Can	1
49	403-11	Thread Stand	1
50	SC299	Wood Screw	2

\*OTHER ATTACHMENTS AVAILABLE, NOT ILLUSTRATED

701-1	"Speed Feed" Shank Button Hopper, for 14 thru 30 ligne shank buttons, standard equipment on Styles 200-21, -22; can be used on Styles 200-6, -7, -8, -9	1
2800 D-2C-14	"So-Thru" Button Hopper, for flat or concave, 14 to 16 ligne buttons, for Styles 200-1, -2, -23, -24	1
2800 D-2C-17	"So-Thru" Button Hopper, for 17 to 19 ligne buttons	1
2800 D-2C-20	"So-Thru" Button Hopper, for 20 to 23 ligne buttons	1
2800 D-2C-24	"So-Thru" Button Hopper, for 24 to 27 ligne buttons	1
2800 D-2C-28	"So-Thru" Button Hopper, for 28 to 30 ligne buttons	1
2800 D-2D-14	"So-Thru" Button Hopper, for dome shaped, 14 to 16 ligne buttons, for Styles 200-1, -2, -23, -24	1
2800 D-2D-17	"So-Thru" Button Hopper, for 17 to 19 ligne buttons	1
2800 D-2D-20	"So-Thru" Button Hopper, for 20 to 23 ligne buttons	1
2800 D-2D-24	"So-Thru" Button Hopper, for 24 to 27 ligne buttons	1
2800 D-2D-28	"So-Thru" Button Hopper, for 28 to 30 ligne buttons	1

\* Machines on which attachments can be used are indicated in parts description.

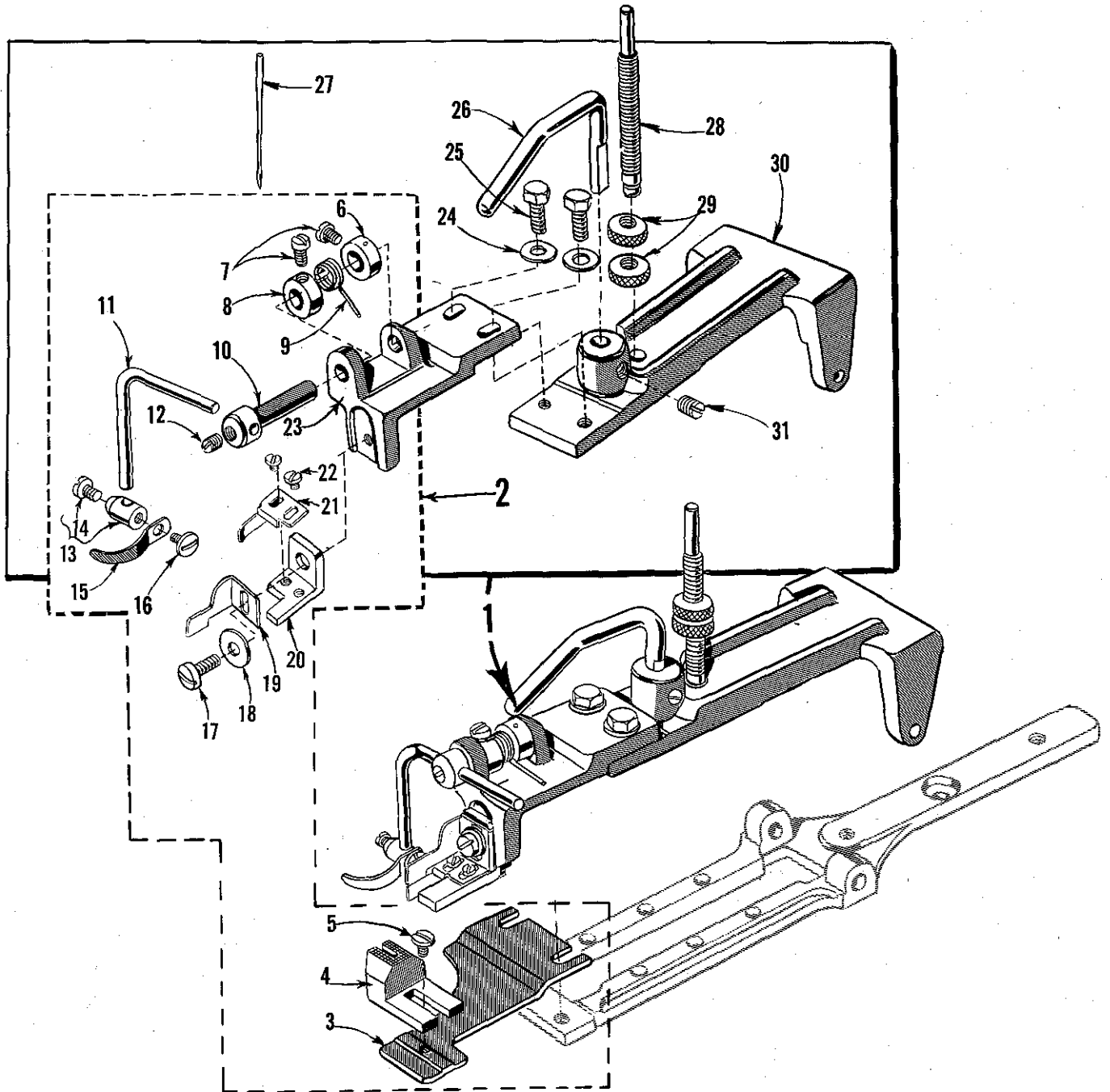

STANDARD SHANK BUTTON HOLDER FOR STYLE 200-27

<u>Ref. No.</u>	<u>Part No.</u>	<u>Description</u>	<u>Amt. Req.</u>
1	430-90-1	Shank Button Holder Assembly, complete, for Style 200-27 -----	1
2	430-90	Shank Button Holder -----	1
3	24-281	Feed Plate -----	1
4	115-125	Work Support Block, .305 inch high, for 10 to 40 ligne buttons-----	1
	*115-128	Work Support Block, .180 inch high, for 10 to 30 ligne buttons-----	1
	*115-133	Work Support Block, .490 inch high, for 40 to 50 ligne buttons-----	1
5	18-307	Screw, for work support block -----	1
6	39-95	Collar, for lever holding shaft -----	1
7	18-623	Screw, for collar -----	2
8	39-95	Collar, for lever holding shaft -----	1
9	21-353	Spring, for lever holding shaft -----	1
10	14-455	Lever Holding Shaft -----	1
11	45-468	Lever -----	1
12	SB15	Screw, for lever -----	1
13	30-90	Clamp, for shank button holder -----	1
14	18-733	Screw -----	1
15	99-351	Shank Button Holder -----	1
16	18-974	Screw, for shank button holder -----	1
17	75 C	Screw, for clamp bracket and clamp blade, upper-----	1
18	51225 W	Washer, for clamp bracket and clamp blade, upper-----	1
19	162-21	Clamp Blade, upper -----	1
20	50-296	Shank Button Clamp Bracket, left -----	1
21	162-20	Clamp Blade, lower -----	1
22	73 A	Screw, for clamp blade, lower -----	2
23	50-238	Bracket, for clamp -----	1
24	40-38	Washer, for bracket -----	2
25	18-873	Screw, for bracket -----	2
26	71-112	Button Holder Lifting Rod-----	1
27	29 LES-110/044	Needle, for use with 115-125 work support block-----	4
	*29 ELS-110/044	Needle, for use with 115-133 work support block-----	1
	*29 LSS -110/044	Needle, for use with 115-128 work support block-----	1
†28	18-965	Screw -----	1
†29	20-60	Knurled Nut-----	2
30	99-308	Button Clamp Holder-----	1
31	18-1087	Set Screw, for button holder lifting rod---	1

\* Available as extra send and charge item.

† Not a component of 430-90-1.

WORK SUPPORTING BLOCKS



115-125



115-128



115-129



115-133



115-136-13



115-136-16



115-136-18



115-136-20



115-153-18



## WORK SUPPORTING BLOCKS

<u>Part No.</u>	<u>Description</u>
115-125	Work Supporting Block, for 10 to 45 ligne buttons, for flat work
115-128	Work Supporting Block, for 10 to 30 ligne buttons, for flat work
115-129	Work Supporting Block, for 10 to 30 ligne buttons, for blind stitch
115-133	Work Supporting Block, for up to 50 ligne buttons
115-136-13	Work Supporting Block, for 13 ligne stay buttons
115-136-16	Work Supporting Block, for 16 ligne stay buttons
115-136-18	Work Supporting Block, for 18 ligne stay buttons
115-136-20	Work Supporting Block, for 20 ligne stay buttons
115-153-18	Work Supporting Block, for 18 ligne stay buttons

ADAPTERS, FOR SHANK TYPE BUTTONS

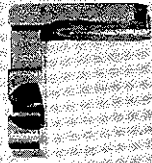

90-22

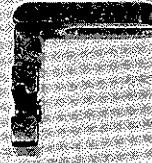

90-25



90-26

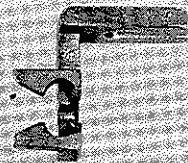

90-29

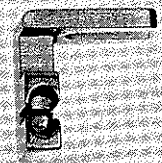

90-32 S

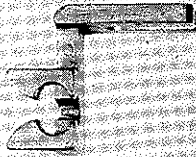

90-33

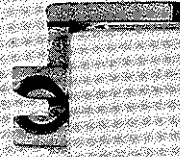

90-34

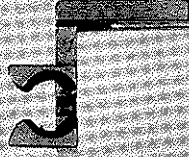

90-35

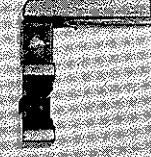

90-36

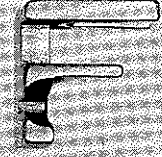

90-37

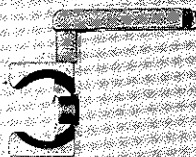

90-39

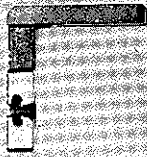

90-40

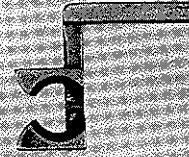

90-41

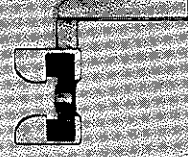

90-42

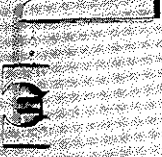

90-43

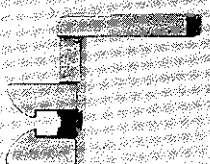

90-44

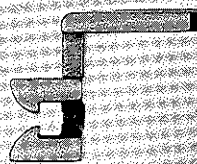

90-45

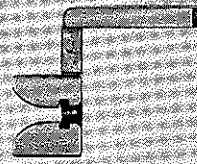

90-47

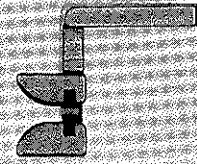

90-48

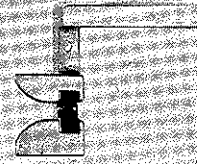

90-48 S

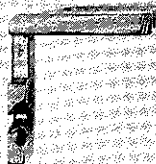

90-49



90-54



90-58

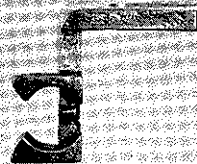

90-60

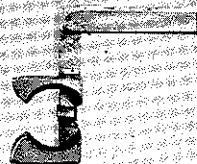

90-60 S

ADAPTERS AND ASSEMBLED CLAMPS, FOR SHANK TYPE BUTTONS

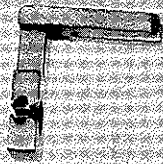

90-61

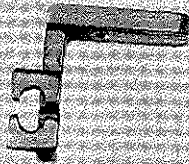

90-62

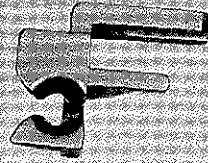

90-63

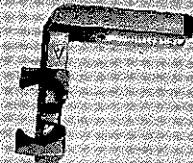

90-64

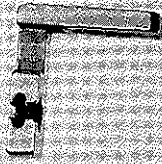

90-66

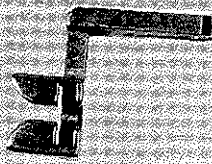

90-67

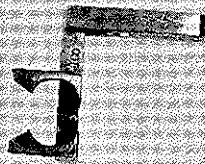

90-68

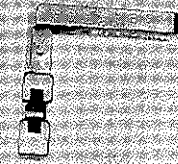

90-69

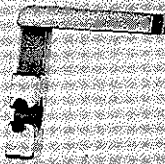

90-72

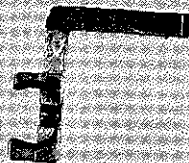

90-74

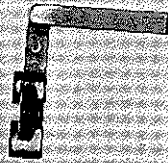

90-76



8-132



430-55

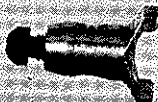

430-58



430-60



430-62

NUMERICAL INDEX OF PARTS

Part No.	Page No.	Part No.	Page No.	Part No.	Page No.	Part No.	Page No.
5-525-1/8.....	37	18-818.....	29	21-336.....	33	34-69.....	23
5-525-11/32.....	37	18-819.....	27	21-337.....	33	34-71.....	23
7-10.....	37	18-826.....	27	21-343.....	31	34-73.....	23
7-11.....	37	18-827.....	27	21-353.....	35, 39	34-75.....	23
8-111.....	31	18-835.....	25	21-360.....	27	34-81.....	23
8-132.....	35	18-854.....	31	21-366.....	27	34-82.....	23
8-147.....	37	18-873.....	33, 35, 39	21-379.....	27	34-91.....	23
14-362.....	21	18-878.....	21	21-381.....	31	34-95.....	23
14-363.....	21	18-907.....	21	21-398.....	33	34-96.....	23
14-364.....	23	18-920.....	31	21-399.....	33	34-104.....	25
14-365.....	27	18-925.....	21	21-407.....	33	35-15.....	29
14-366.....	23	18-929.....	33, 35	21-408.....	37	35-16.....	27
14-368.....	27	18-930.....	33, 35	21-411.....	33	35-17.....	27
14-399.....	19	18-931.....	33, 35	21-414.....	31	35-20.....	23
14-455.....	35, 39	18-934.....	23, 31	21-449.....	37	36-21.....	23
14-488.....	27	18-945.....	33, 35	21-457.....	27	39-95.....	35, 39
SB15.....	35, 39	18-949.....	23	22-175.....	31	39-107.....	23
16-288.....	19	18-958.....	21	22-195.....	31	39-131.....	23
16-289.....	19	18-959.....	21	22-205.....	33	39-143.....	23
16-291.....	19	18-963.....	33	22-206.....	31	39-151.....	25
16-292.....	19	18-965.....	35, 39	22-C214-13.....	29	39-C255.....	33
16-297.....	19	18-966.....	29	22-219.....	29	40-38.....	25, 29, 33, 35, 39
16-334.....	19	18-967.....	21	22-221.....	31	40-63.....	21
16-398.....	19	18-968.....	21	22-224.....	33	40-101.....	37
16-411.....	19	18-970.....	33	22-235.....	27	40-135.....	21, 23
16-412.....	19	18-974.....	37, 39	22-238.....	31	40-143.....	27
17-124.....	29	18-982.....	21	22-251.....	31	40-148.....	27
17-155.....	35	18-984.....	23	22-255.....	19	40-169.....	21
18-39.....	21, 25	18-986.....	37	22-266.....	27	40-169.....	21
18-71.....	21	18-987.....	37	22-289.....	33	40-170.....	31
18-75.....	33, 35	18-996.....	21, 23, 25	22-347.....	33	40-181.....	37
18-125.....	35	18-997.....	31	24-281.....	29, 35, 39	40-188.....	31
18-C186.....	33	18-1010.....	33	24-299.....	37	40-198.....	27
18-272.....	21	18-1022.....	29	24-304.....	37	41-41.....	31
18-280.....	27	18-1023.....	29	24-338.....	29	41-47.....	21
18-286.....	31	18-1033.....	37	25-11.....	21	41-49.....	31
18-307.....	35, 39	18-1035.....	19	26-147.....	31	41-53.....	31
18-318.....	35	18-1036.....	33	26-163 A.....	27	42-34.....	27
18-330.....	25, 29	18-1047.....	31	27-155.....	23	43-27.....	37
18-375.....	33	18-1076.....	31	27-168.....	23	44-288.....	21
18-391.....	21	18-1077.....	31	27-169.....	21	44-334.....	21
18-392.....	27, 29	18-1087.....	33, 35, 39	27-170.....	21	45-288.....	29
18-547.....	31	18-1088.....	27, 31	27-171.....	21	45-290.....	29
18-562.....	27	18-1112.....	25	27-189.....	23	45-327.....	27
18-596.....	33	18-1128.....	33	27-190.....	23	45-331.....	25
18-619.....	25, 27, 29	20-34.....	25, 27	27-191.....	23	45-332.....	33, 35
18-623.....	33, 35, 39	20-45.....	33	27-225.....	23	45-333.....	19
18-626.....	29	20-60.....	31, 35, 39	27-226.....	23	45-335 A.....	21
18-629.....	25	20-80.....	21	29 ELS-110/044.....	39	45-346.....	33
18-634.....	23	20-81.....	21	29 LES-110/044.....	39	45-347.....	33
18-677.....	33	20-98.....	31	29 LSS-110/044.....	39	45-348.....	27
18-725.....	21	20-109.....	29	30-75.....	35	45-372.....	35
18-730.....	21, 23, 25	20-123.....	33, 35	30-88.....	33	45-404.....	27
18-732.....	27	20-127.....	21	30-89.....	33	45-416.....	29
18-733.....	35, 39	20-128.....	27	30-90.....	39	45-424.....	37
18-738.....	19	21-96.....	19, 27	32-191.....	19	45-426.....	19
18-745.....	27	21-229.....	21	32-192.....	19	45-432.....	33
18-747.....	25, 27	21-284.....	31	32-198.....	31	45-434.....	31
18-750.....	31, 35, 37	21-287.....	29	32-209.....	31	45-458.....	35
18-752.....	31	21-295.....	19	32-303.....	31	45-459.....	35
18-766.....	29	21-300.....	29	34-35.....	23	45-468.....	39
18-786.....	31	21-310.....	31	34-47.....	23	45-471.....	35
18-800.....	21	21-315.....	33, 35	34-53.....	23	45-472.....	35
18-809.....	27	21-317.....	33	34-54.....	23	45-490.....	27
18-814.....	29	21-321.....	19	34-65.....	25	45-498.....	37
18-816.....	31	21-322.....	25	34-68.....	23	45-503.....	27

NUMERICAL INDEX OF PARTS

Part No.	Page No.	Part No.	Page No.	Part No.	Page No.	Part No.	Page No.
46-135	27	99-344	33	190-3 L	23	1029 L	23
46-137	29	99-345	31	CS231	31	1036 L	29
46-138	29	99-351	39	SC299	37	1158 L	19,27
46-162	27	110-205	29	CS303-1/2	27	1160 L	19,25,29,31,33
46-168	25	110-206	29	CS327	35	1170 L	25
46-169	25	110-213	31	CS337	19,25,29	1183 L	31
46-173	29	110-302	31	403-11	37	1185 L	27
46-174	29	110-304	31	407-10	37	1189 L	33
46-175	27	110-318	29	407-11	37	1206 L	27
46-181	19	110-328	29	408-147	37	1220 L	19
46-182	19	110-333	31	413 D	37	1221 L	31
46-183	19	110-334	31	421 D-34	37	1235 L	19
49-25	23	110-404	35	424-299	37	1311 L	25
49-33	23	115-106	27	430-55	35	1316 L	31
50-215	19	115-107	31	430-57-12	35	1333 L	21
50-238	35,39	115-108	29	430-63	33	1504 L	37
50-247	33	115-125	39,41	430-63-6	33	1776 L	33
50-265	37	115-127	35	430-75	35	2339 F	21
50-295	31	115-128	39,41	430-75-1	35	2800 D-2C-14	37
50-296	39	115-129	41	430-77	35	2800 D-2C-17	37
51-20	21	115-133	39,41	430-86	35	2800 D-2C-20	37
51-22	25	115-136-13	41	430-88	33	2800 D-2C-24	37
WR56	37	115-136-16	41	430-90	39	2800 D-2D-14	37
57-23	21	115-136-18	41	430-90-1	39	2800 D-2D-17	37
57 WB	31	115-136-20	41	432-263	31	2800 D-2D-20	37
WR57	37	115-137	29	432-303	31	2800 D-2D-24	37
58-39	21	115-151	35	432-305	19	2800 D-2D-28	37
59-6	37	115-153-18	41	432-306	19	2800 D-2D-28	37
61-32	31	115-171	37	433-139	21	4110-317	29
61-33	31	115-175	27	434-40	23	4110-329	29
61-80	23	117-39	21	434-101	25	4115-104	27
63-32	21	117-40	21	434-102	25	4119-86	19
68-21	31	122-45	35	439-153	33	4124-49	21
68-22	31	122-46	35	444-334	21	4124-50	21
68-29	33	122-58	23	445-286	27	4135-9	37
69-16	29	130-9	35	445-298	21	4186-16	19
69-17	29	131-C163-1	35,37	445-349	23	4187-3	27
70-50	23	131-C163-2	19	445-370	27	12538	33
71-74	21	135-9	37	445-405	27	12934 A	37
71-92	27	137-19	21	445-432	33	12957 E	19
71-97	33	138-15	27	446-136	29	21201	37
71-112	33,35,39	141-4	19	446-173	29	21657 E	31
71-114	33	142-6	25	447-105	21	22548	31
71-124	27	144-25	19	458-39	21	22585 A	25
73 A	39	144-31	31	CS462	21	22651 ED-6	27
75 C	39	155-14	29	468-21	31	22652 E-20	31
75-267	19	157-8	33	468-22	31	22653 B-10	27
79-31	29	157-13	27	475-231	37	22653 E-14	27
79-37	21	158-11	33	478-10	21	22757	37
SB79	31	158-17	29	478-27	21,23	22768 B	37
89-65	25	158-19	29	490-49	35	22894 P	37
90-49	35	158-21	33,35	650-14	37	28604 P	37
98	21	158-25	35	652-16	27,37	41358	37
99-270	33	158-29	29	652 N-14	21	51225 W	39
99-308	35,39	162-20	39	660-264	37	51758	31
99-313-17	37	162-21	39	666-19	21	52958 H	33
99-313-18	37	164-39	23	701-1	37	60038 K	27
99-313-19	37	164-40	23	787 L	19	61292 H	31
99-313-20	37	164-41	23	835 L	27	61470 D	31
99-313-22	37	166-7	21	861 L	25	62271 C	31
99-313-23	37	166-10	33	888 L	31		
99-313-24	37	166-11	25	1003 L	19,21		
99-316	33	180-4	25	1005 L	19,21,23		
99-316-1	35	182-15	37	1009 L	19,21		
99-326	33	182-16	33	1022 L	21		
99-328	33	190-2 L	21	1025 L	21		







# Style 200-16

## Suggested Minimum Spare Parts List\*

Part Number	Description	Minimum Quantity Per 5 Machines	Part Number	Description	Minimum Quantity Per 5 Machines
29 S	Needles (specify size)	100	18-996	Screw	2
21-321	Spring	2	26-163	Stop motion plunger	1
18-272	Screw, needle	4	1206 L	Screw	2
44-288	Pulley clutch disc	1	21-381	Spring	1
21-229	Spring	2	18-818	Screw	1
36-21	Looper	2	18-730	Screw	2
18-949	Looper clamping screw	2	18-970	Screw	2
18-1088	Screw	1	40-38	Washer	2
60038 K	Washer	1	30-89	Clamp	1
18-750	Screw	1	18-677	Screw	2
21-366	Spring	2	21-399	Spring, lower	1
18-1087	Set screw	2	21-398	Spring, upper	1
21-416	Stop motion disc spring	30	166-10	Pawl	1
45-302	Lever	1	40-188	Washer	1
18-280	Screw	1	51-20	Stop motion disc latch	1
18-71	Screw	2	18-997	Screw	1
18-907	Screw	2	1333 L	Set screw	1
122-29	Loop positioning finger	1	18-920	Screw	4
18-634	Screw	2	28604 P	Grease tube	1
1005 L	Screw	2			

\*The parts and quantities listed above are intended to assist you in setting up the initial inventory of spare parts. An efficient inventory can only be established according to actual usage. The nature of the sewing operation will determine actual usage.



# Style 200-26

## Suggested Minimum Spare Parts List\*

Part Number	Description	Minimum Quantity Per 5 Machines	Part Number	Description	Minimum Quantity Per 5 Machines
29 S	Needles (specify size)	100	18-634	Screw	2
21-321	Spring	2	1005 L	Screw	2
18-272	Screw, needle	4	18-996	Screw	2
44-288	Pulley clutch disc	1	26-163	Stop motion plunger	1
21-229	Spring	2	1206 L	Screw	2
36-21	Looper	2	21-381	Spring	1
18-949	Looper clamping screw	2	18-818	Screw	1
18-1088	Screw	1	18-730	Screw	2
60038 K	Washer	1	LS-314	Screw	2
18-750	Screw	1	40-139	Washer	2
21-366	Spring	2	24-244	Feed plate	1
18-1087	Set screw	2	18-873	Screw	2
21-416	Stop motion disc spring	30	40-188	Washer	1
45-302	Lever	1	51-20	Stop motion disc latch	1
18-280	Screw	1	18-997	Screw	1
18-71	Screw	2	1333 L	Set screw	1
18-907	Screw	2	18-920	Screw	4
122-29	Loop positioning finger	1	28604 P	Grease tube	1

\*The parts and quantities listed above are intended to assist you in setting up the initial inventory of spare parts. An efficient inventory can only be established according to actual usage. The nature of the sewing operation will determine actual usage.

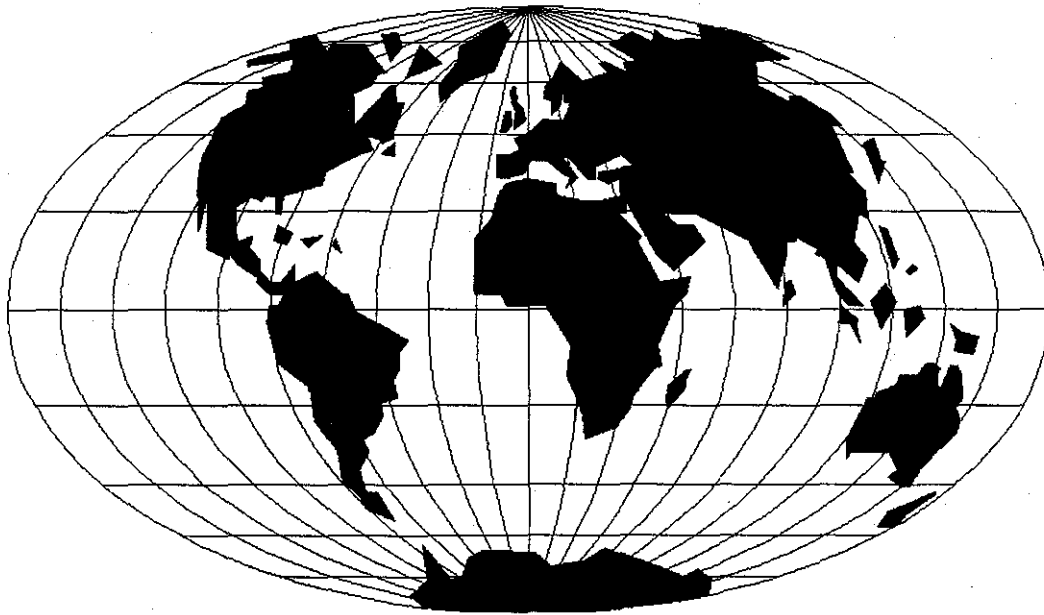

## WORLDWIDE SALES AND SERVICE

Union Special Corporation maintains sales and service facilities throughout the world. These offices will aid you in the selection of the right sewing equipment for your particular operation. Union Special Corporation representatives and service technicians are factory trained and are able to serve your needs promptly and efficiently. Whatever your location, there is a qualified representative to serve you.

---

**Corporate Office:** One Union Special Plaza  
Huntley, IL 60142  
Phone: 708•669•5101  
Fax: 708•669•1096

**European Distribution Center:** Union Special GmbH  
Raiffeisenstrasse 3  
D-71696 Möglingen, Germany  
Tel: 49•07141•247•0  
Fax: 49•7141•247•100

Brussels, Belgium  
Charlotte, N.C.  
Commerce, CA  
El Paso, TX  
Hong Kong, China  
Huntley, IL  
Leicester, England  
Lille, France  
Miami, FL  
Milan, Italy  
Mission, TX  
Möglingen, Germany  
Montreal, Quebec  
Osaka, Japan

Other Representatives throughout  
all parts of the world.



*Union Special*  
INDUSTRIAL SEWING EQUIPMENT