

CATALOG NO.

194-23

First Edition

STYLES

200-38

200-45

INSTRUCTIONS FOR OPERATION, MAINTENANCE AND ADJUSTMENTS WITH ILLUSTRATED PARTS LIST

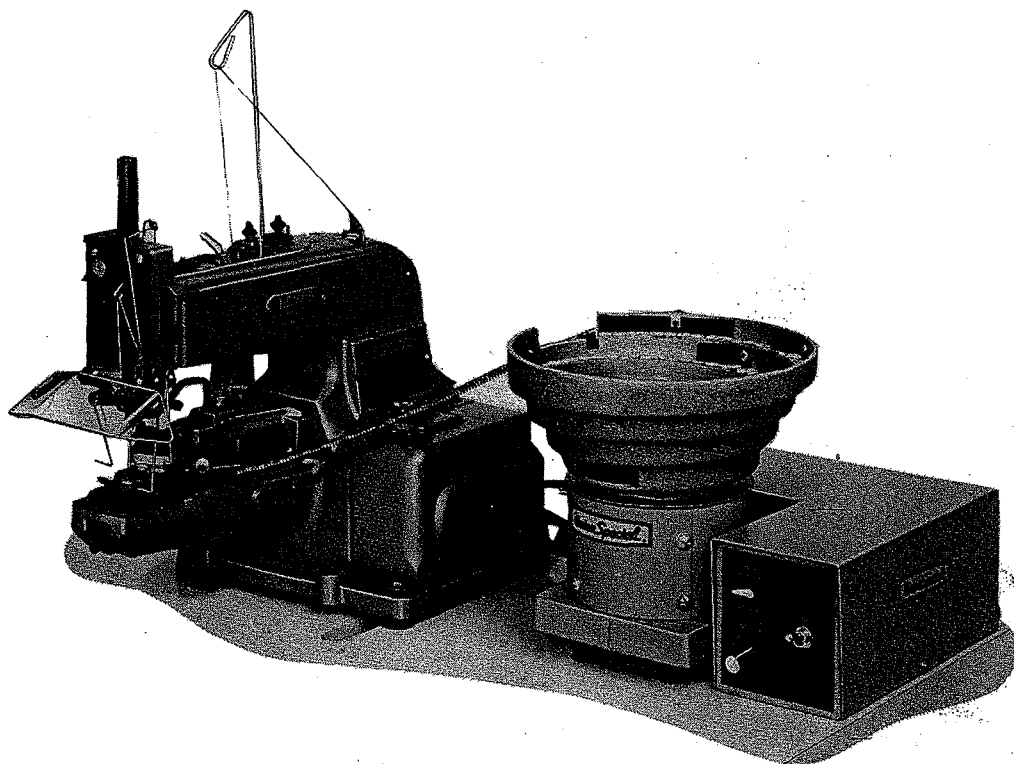

CLASS 200

BUTTON SEWING MACHINES

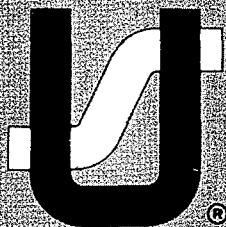

Finest Quality

Union Special[®]
Industrial Sewing Equipment

FOREWORD

This technical manual has been prepared to guide you in the installation and maintenance of your new UNION SPECIAL sewing machine. Careful attention to the instructions for installing, operating and adjusting these machines will enable you to maintain the superior performance and reliability designed and built into every UNION SPECIAL machine.

The Adjusting Instructions portion of this manual explains in detail the proper setting for each of the components related to forming the stitch and completing the functions of the machine. The text of the Adjustments is divided into two sections—Check and Procedure. The Check depicts conditions when the parts are adjusted correctly. The Procedure is given to explain the proper steps to be taken in the event adjustments are required. Figures are used to illustrate the adjustments using reference letters to point out the specific items discussed.

The adjustments are presented in a sequence so that a logical progression is accomplished. Some adjustments performed out of sequence may have an adverse effect on the function of other related parts.

To simplify identification of repair parts, the mechanisms are illustrated by exploded views. These illustrations will usually be shown in conjunction with a KEY VIEW which presents the mechanisms of the machine assembled. The specific parts illustrated on this page will appear shaded on the KEY VIEW.

Catalog No. 194-23 FOR Styles 200-38 and 200-45

First Edition

Copyright 1980

By

Union Special Corporation
Rights Reserved in All Countries

Printed in U.S.A.

November, 1980

TABLE OF CONTENTS

TITLE	PAGE
GENERAL INFORMATION	5
Class Description.....	5
Machine Styles.....	5
Needles.....	6
INSTALLING AND OPERATING STYLES 200-38 AND 200-45	7
Threading.....	8
Lubrication.....	8
Machine Speed.....	8
Threading and Oiling Diagram.....	9
Assembling the Automatic Button Feeder.....	10
Power Box 29480 RT.....	10
Automatic Cycling Device Kit No. 29480 RW.....	12
Vane Switch.....	14
Adjusting Button Vibrator Bowl.....	14
Check Button Orientation.....	15
Operation of Style 200-38 Fitted with Cycling Device No. 29480 RW.....	15
ADJUSTING INSTRUCTIONS FOR STYLES 200-38 AND 200-45	16
Stitching Cycle.....	16
Clutch.....	16
Stop Motion Plunger.....	16
Stop Motion - Pawl and Latch.....	17
Stop Motion Cam (Inner Cam).....	17
Soft Stop Cam (Outer Cam).....	18
Clamp Drive Cams.....	18
Clamp Lifting Link.....	18
Setting the Number of Stitches.....	19
Stitch Formation.....	19
Needle Bar.....	19
Loop Positioning Finger.....	20
Looper Timing.....	20
Needle Guard.....	20
Feed Plate.....	21
Thread Tension.....	21
Tension Release Levers.....	21
Thread Nipper.....	21
Thread Pull-off Lever.....	21
Automatic Thread Tension.....	22
Thread Trimming Knives.....	22
Sewing Two or Four Hole Buttons.....	23
Button Clamp.....	24
Clamp Stop Pin.....	24
Clamp Lifting Lever Stop.....	24
Button Clamp Opener - Style 200-45.....	24

TABLE OF CONTENTS (Cont.)

TITLE	PAGE
ADJUSTING AUTOMATIC BUTTON FEEDING COMPONENTS FOR STYLE 200-38	25
Button Positioning Sequence	25
Thread Wiper	25
Button Holder Springs	26
Button Guiding Cam	26
Gear Rack Drive Cam	26
Gear Rack Connecting Rod	27
Button Orienting Pin	27
Escapement Lever	28
Escapement Lever Release	28
Button Alignment	28
Orienting Pin Lifter Lever	29
Orienting Pin Pressure Spring	29
Button Unloading Spring	29
Button Guide Track	30
Safety Stop	30
Procedure for Changing Size of Buttons	30
ORDERING REPAIR PARTS	31
EXPLODED VIEWS	33
Base, Covers, Bushings, Sewing Guard	33
Miscellaneous Plates, Thread Handling Parts	35,37
Needle Drive, Clutch, Stop Motion Parts	39
Button Clamp Lifter, Stop Motion, Nipper Parts	41
Cams, Looper Drive, Stitch Selection Parts	43
Button Clamp, Positioning Parts and Feed Plate	45
Orienting Pin Lifter, Knife Drive and Thread Wiper Parts	47
Button Feeder Clamp Assembly For Style 200-38	49,51
Button Bowl, Vibrator Feeder and Standard Accessories For Style 200-38	53
Optional Accessories, Motors and Button Gauge	55
NUMERICAL INDEX OF PARTS	56

CLASS DESCRIPTION

High speed, single needle, cylinder bed, chainstitch, clamp feed, button sewing machines. The stitching cycle is automatic—cam driven with stop motion clutch. The button clamp travels right to left when set for two hole buttons, and travels right to left with front to back crossover when set for four hole buttons. Machines fitted with scissor action thread trimmer. The thread is automatically cut and the clamp lifts at end of the stitching cycle. Single treadle operation.

TECHNICAL DATA

STITCH TYPE Spec. 101, single thread formed by rotary looper

BUTTON CLAMP TRAVEL Right to left - min. 3/32 inch (2.4 mm), max. 1/4 inch (6.4 mm)

Front to back - min. 3/32 inch (2.4 mm), max. 1/4 inch (6.4 mm)

MAXIMUM SPEED 1500 R.P.M.

BUTTON SIZE RANGE Style 200-38 sews 17 to 22 ligne (10.8 to 14.0 mm) buttons

Style 200-45 sews 14 to 45 ligne (8.9 to 28.6 mm) buttons

STITCH RANGE Style 200-38 produces 16 stitches (12 parallel, 1 crossover and 3 tying stitches)

Style 200-45 produces 16 stitches (12 parallel, 1 crossover and 3 tying stitches). When set for 1/2 cycle produces 8 stitches (6 parallel and 2 tying stitches).

MACHINE STYLES

200-38 Button sewer with automatic, mechanical button feeding and positioning system built as an integral part of the machine. The sequential functions of the button orienting components are synchronized by means of direct mechanical linkage to the drive mechanisms of the machine. A mechanical safety interlock prevents operation when the button is not properly presented to the sewing station. For sewing two and four hole flat buttons to shirts, blouses, pajamas, etc.

OPTIONAL EQUIPMENT: Kit no. 29480 RW—Cycling device is available for Style 200-38 to automatically cycle the machine at pre-determined intervals. Features of this device include pacing the operator so that a high level of production is maintained. Also, since it functions automatically the operator is not required to manually press the operating treadle.

200-45 Button sewer for manual feeding of buttons. Includes scissor action thread trimmer. The clamp automatically releases the button at the end of the stitching cycle. For sewing two or four hole flat buttons to shirts, blouses, pajamas, etc.

OPTIONAL EQUIPMENT: Various clamp assemblies are available to adapt the machine for sewing shank buttons, snap fasteners, hooks and eyes, and for tacking applications. These items are listed in Catalog No. 194-4.

IDENTIFICATION OF MACHINES

Each UNION SPECIAL LEWIS machine carries a Style number, which in this Class of machines, is stamped in the Style plate on the left side of the arm.

The serial number of each machine is stamped in the right side of the cylinder toward the back.

NEEDLES

Needles for Class 200 machines are available in four length categories—short, long with short shank, long with extra short shank and extra long with extra short shank.

Normally, the shortest needle required to perform a given operation should be used. To determine the proper length of needle to use, load the button and material into the sewing area ready for stitching and then manually rotate the pulley in operating direction. When the needle is at its lowest position the shank of the needle should clear the button hole by at least 1/32 inch (0.8 mm). If this condition is not met then a longer needle or one with a shorter shank must be used.

On Style 200-45 adapted for sewing shank buttons, consideration should be given to the diameter of the button, thickness of the shank and the height of the work support block.

When changing from short to long, to extra long needles, or vice versa, the needle bar height must be set to the proper timing lines as described in the Adjusting Instructions section of this catalog.

Selection of proper needle diameter is determined by size of thread, weight of material, and the type of button used.

To have needle orders promptly and accurately filled, an empty container, a sample needle, or the type number and size should be forwarded. A complete order would read: "100 Needles, Type 29S-100/040".

Unless instructions to the contrary are received, machines will be sewed off and shipped with the following needles:

Machine Style	Needle
200-38	29S-100/040
200-45	29S-100/040

CHANGING NEEDLES

When changing the needle, make sure that it is inserted in the needle bar as far as it will go, with the long groove to the front and the spot or scarf to the rear. Tighten the set screw securely.

A cross hole drilled in the needle bar can also be used to determine if the needle has been inserted as far as it will go.

Immediately discard any needle which may have a hooked or blunt point.

The following needles are available for Class 200 machines:

Blade Dia.	Short	Long with Short Shank	Long with Extra Short Shank	Extra Long with Extra Short Shank
.036"	29S-090/036	29LSS-090/036	—	—
.040"	29S-100/040	29LSS-100/040	29LES-100/040	—
.044"	29S-110/044	29LSS-110/044	29LES-110/044	29ELS-110/044
.049"	29S-125/049	29LSS-125/049	29LES-125/049	29ELS-125/049
.054"	—	29LSS-140/054	—	—

INSTALLING AND OPERATING STYLES 200-38 AND 200-45

To assure proper operation, the following assembly and operating procedures are recommended:

Carefully unpack cartons, making certain that none of the small parts are discarded with the packing materials.

INSTALLING MACHINE

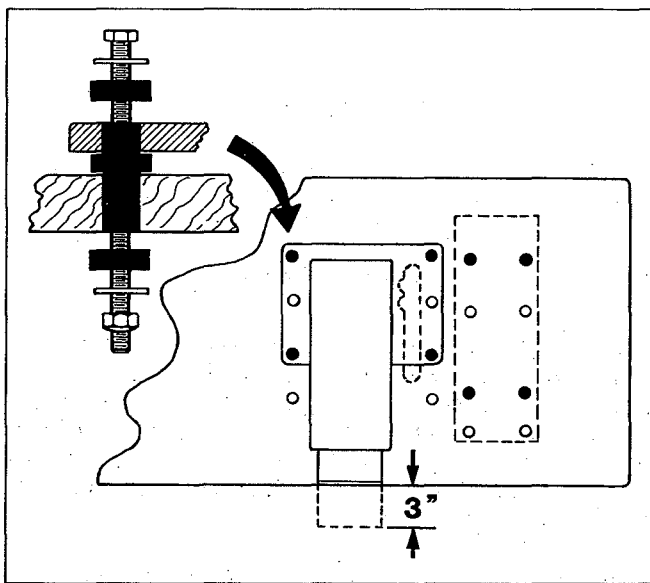

Fig. 1

The tableboard furnished is prepared with two sets of mounting holes for the machine and motor hanger. Mounting the machine using the rear set of holes as shown (Fig. 1) will position the front end of the cylinder at the edge of the tableboard. Using the front set of holes extends the end of the cylinder three inches to the front of the tableboard.

Determine the location of the machine required and assemble to tableboard using the isolators, bolts, nuts, and washers furnished as shown (Fig. 1).

MOUNTING MOTOR

The motor hanger is mounted to the underside of the tableboard using either the front or rear set of holes that will correspond to the position selected for the machine. The pulley shaft of the motor should be located directly below the machine pulley.

Assemble the motor to the motor hanger as shown (Fig. 2). Install the motor pulley onto the shaft.

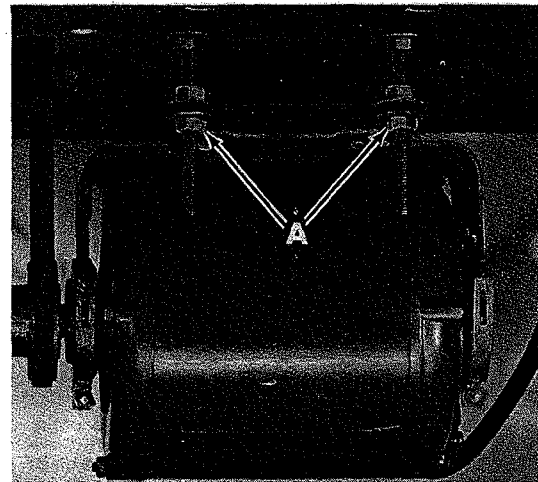

Fig. 2

Attach the "V" belt and adjust the motor hanger up or down (nuts A) to put the proper tension on the belt.

Assemble the chain from the treadle to the stop motion trip lever of the machine.

ASSEMBLING THREAD STAND AND LIGHT

Assemble the thread stand and light, then mount to the tableboard using the holes provided.

NOTE: The motor furnished does not have provisions to supply current for the sewing light. The sewing lights listed below are available for Class 200 machines.

21233-FX—Table mounted light for 110 volts.

21233-SF—Table mounted light for 6 volts. Power outlet supplied with optional power box on Styles 200-38.

ELECTRICAL REQUIREMENTS FOR DRIVE MOTOR

The motors listed below are for use with Class 200 machines.

Motor No.	Specifications
28741-H	1 phase, 110 volts, 60 Hz.
28742-AG	3 phase, 208/220 volts, 50/60 Hz. 3 phase, 380/440 volts, 50/60 Hz.

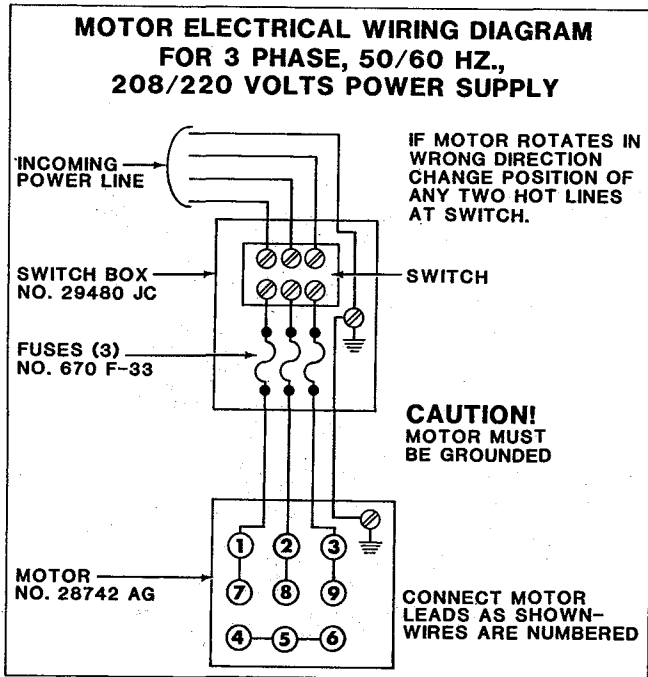

Fig. 3

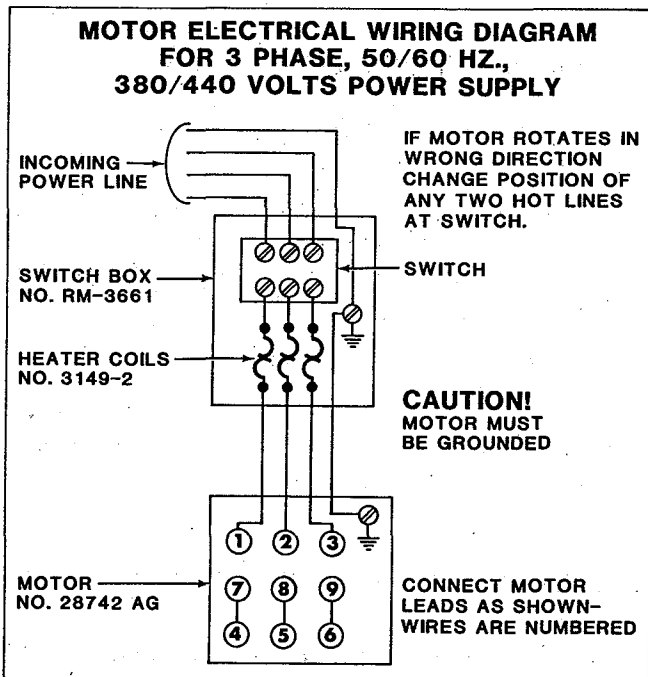

Fig. 4

CAUTION! Motor No. 28742-AG must be wired according to the voltage at power source. Instructions for proper wiring are shown in wiring diagrams (Figs. 3 and 4).

The nine leads from the motor are numbered. Connect as shown in the wiring diagrams.

If the motor rotates in the wrong direction change the position of any two hot lines. The machine pulley should rotate in a clockwise direction.



MOTOR MUST BE GROUNDED.

THREADING

To thread machine, put in stop position, and thread in accordance with diagram.

LUBRICATION

Class 200 machines require manual lubrication. Oiling twice daily is sufficient when the machines are used under normal operating conditions. Extreme duty cycles may require oiling more frequently. Prior to use in the morning and again before use in the afternoon, oil should be applied to the oil holes marked in RED on the machine.

The oil used should be a good quality straight mineral oil having a Saybolt viscosity of 90 to 125 seconds at 100° Fahrenheit.

For access to all the parts that require oiling it is necessary to remove or open the covers. The oil holes are easily located by referring to the THREADING AND OILING DIAGRAM.

IDLER PULLEY LUBRICATION

The pulley contains a reservoir for grease to lubricate its bearings. Access to the reservoir is obtained by removing the plug screws marked "A" on the THREADING AND OILING DIAGRAM. A tube of grease is furnished with the machine. Periodically the plug screw should be removed, the grease level checked and replenished if required.

For additional tubes of grease order part No. 28604P.

MACHINE SPEED

The recommended speed of these machines is 1500 R.P.M.

THREADING AND OILING DIAGRAM FOR STYLES 200-38 & 200-45

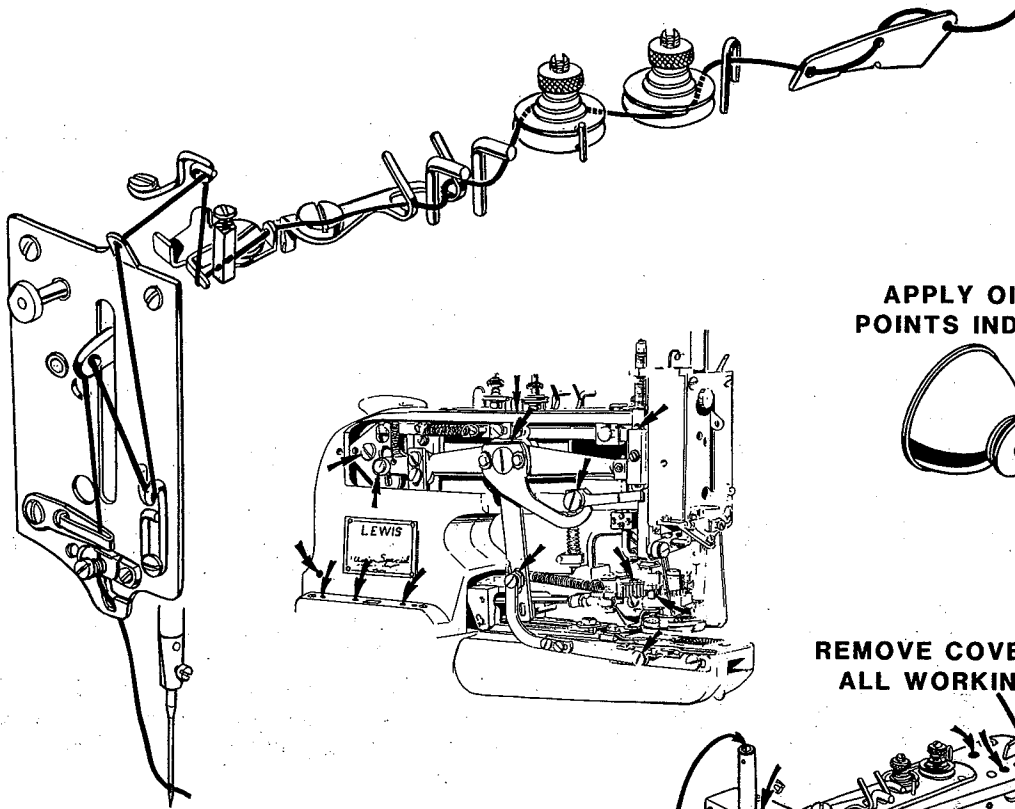

APPLY OIL TO
POINTS INDICATED

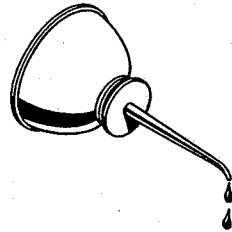

REMOVE COVER AND OIL
ALL WORKING PARTS

OIL NEEDLE BAR

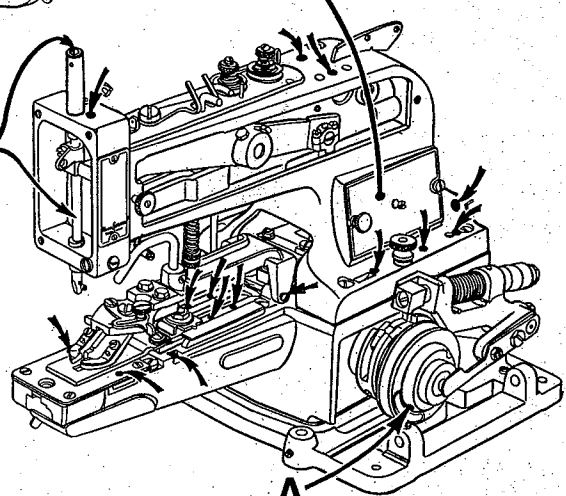

A
GREASE HERE

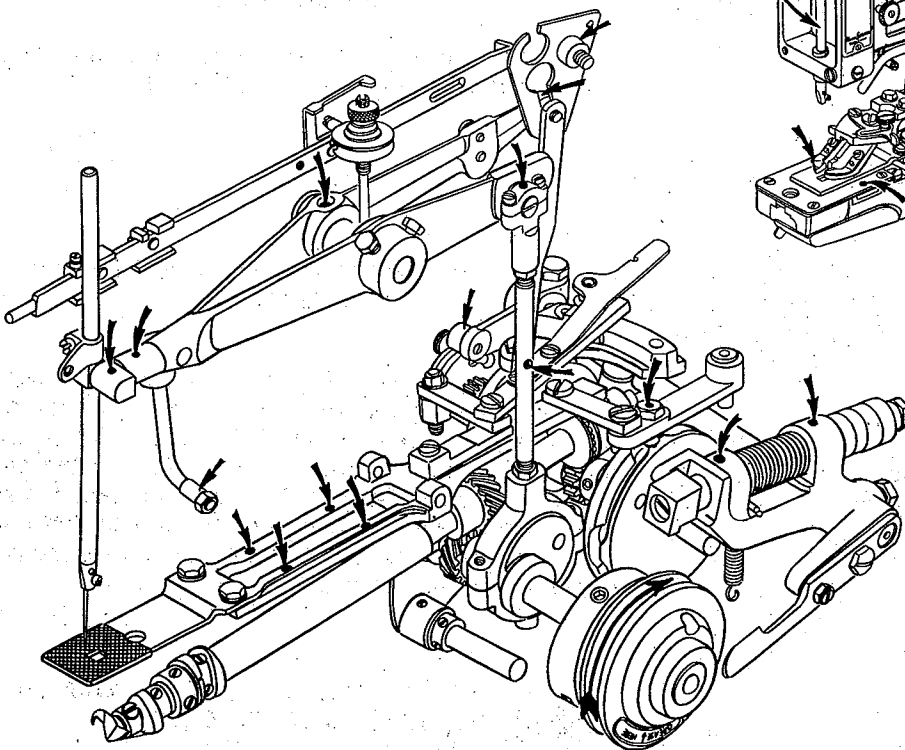

THE FOLLOWING INSTRUCTIONS APPLY ONLY TO THE AUTOMATIC BUTTON FEEDING COMPONENTS FOR STYLE 200-38. FOR FURTHER INFORMATION ON STYLE 200-45 SEE THE ADJUSTING INSTRUCTIONS SECTION OF CATALOG

ASSEMBLING THE AUTOMATIC BUTTON FEEDER

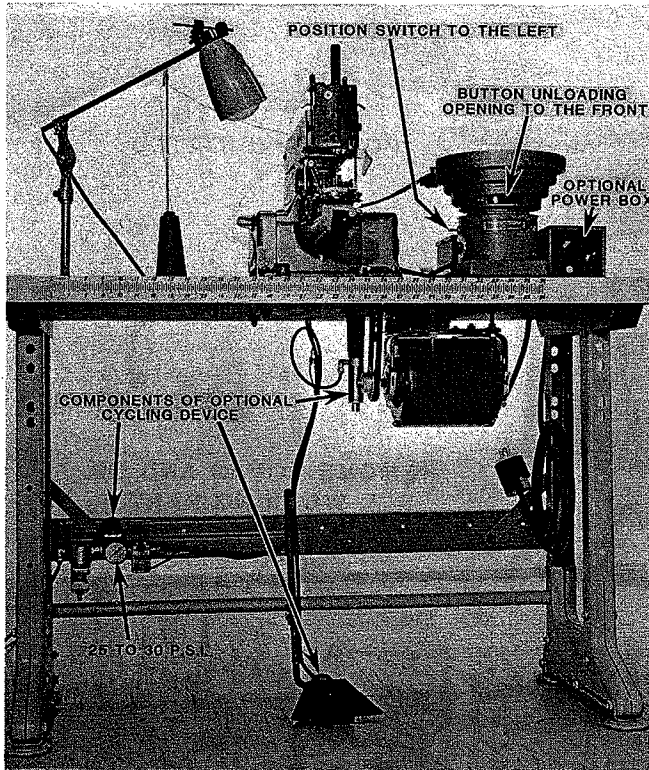

Fig. 5

Place vibrator base onto isolators placed in holes provided in the tableboard (Fig. 5), position switch and control knob to left facing the machine.

Assemble the button bowl to the vibrator base using screw furnished (C, Fig. 6). Position bowl so that the button unloading opening faces toward the front (Fig. 5).

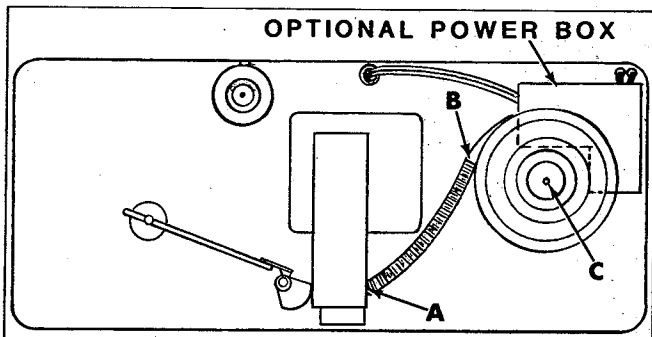

Fig. 6

Mount the button guide track to the bowl and to the button clamp assembly on the machine (Points A and B, Fig. 6).

CONNECTING POWER SUPPLY TO BUTTON VIBRATOR

THE BUTTON VIBRATOR REQUIRES 110 VOLTS.

110 Volt Supply Available

If a separate 110 volt supply is convenient the power to the vibrator is obtained by adding the proper plug and connecting to the power source.

110 Volt Supply NOT Available

To convert the power source from 220/380/440 volts to the required 110 volts, it is necessary to use the optional power box assembly No. 29480 RT.

POWER BOX 29480 RT

Mount the power box to the right rear corner of the tableboard in the holes provided (Fig. 6).

INSTRUCTIONS FOR WIRING POWER BOX NO. 29480 RT

Use wiring diagram (Fig. 7) for reference when making the following connections. Connect the incoming power leads to the upper three terminals of the power switch. Connect the ground (green) lead to the brass grounding screw. Connect the motor leads to the side tabs of the fuse holders with ground to the same brass grounding screw. Connect the motor leads as explained in Figs. 3 and 4.



DO NOT ASSEMBLE OR REMOVE COVER WITHOUT DISCONNECTING ELECTRICAL SUPPLY.

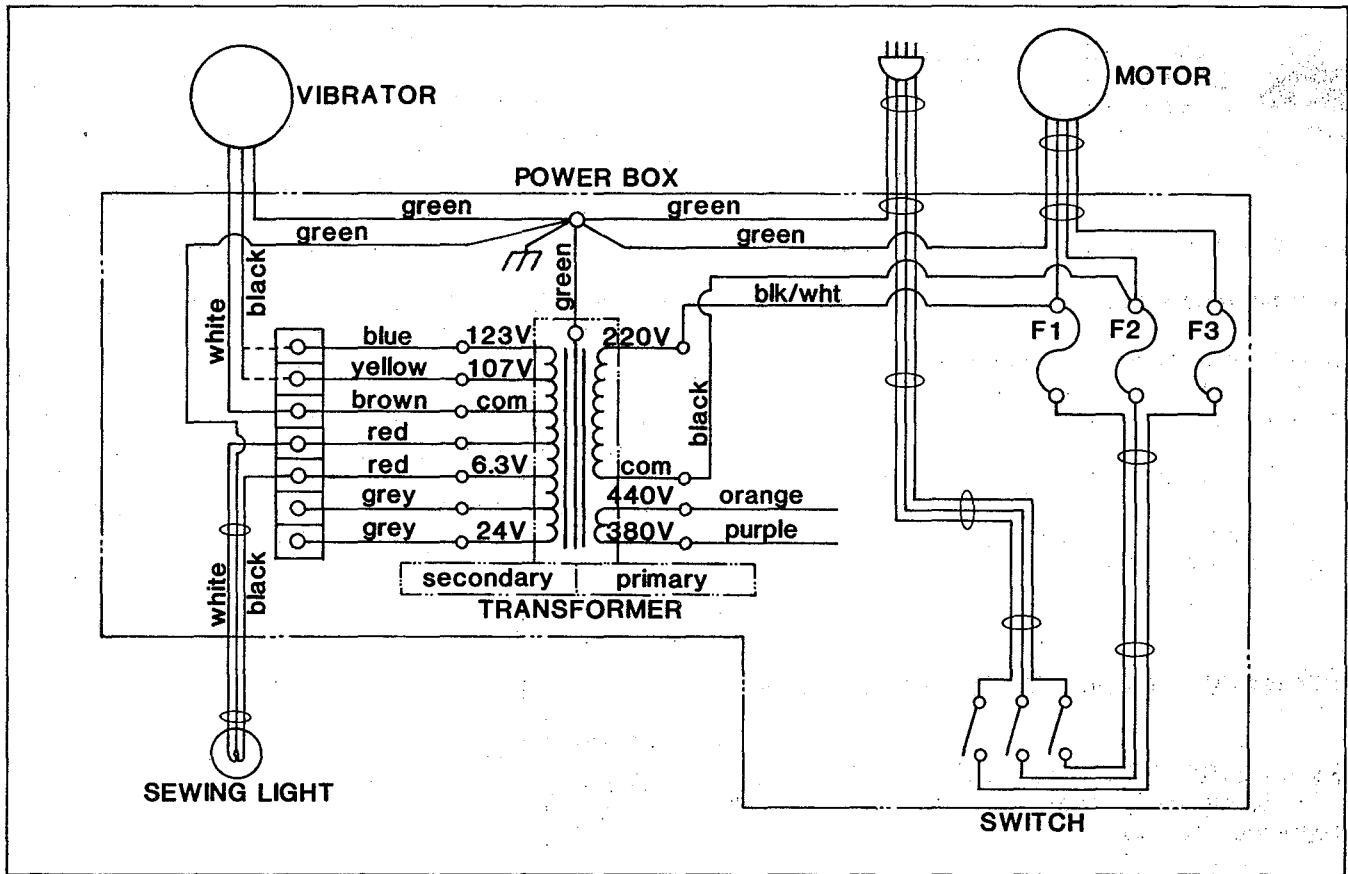

Fig. 7

VIBRATOR CONNECTIONS FOR 220, 380 AND 440 VOLTS

MEASURE LINE VOLTAGE then connect the two wires (black and white) from the vibrator to the barrier strip opposite the wires from the transformer as indicated:

Supply Voltage	Secondary Transformer Wires
220 V or less.....	Brown and Blue
220 V or more.....	Brown and Yellow
380 V or less.....	Brown and Blue
380 V or more.....	Brown and Yellow
440 V or less.....	Brown and Blue
440 V or more.....	Brown and Yellow

Now connect the green wire from the vibrator to the brass grounding screw. Connect the leads for the sewing light to the barrier strip opposite the two red wires from the transformer. Assemble the rubber grommets into the grooves in the cable plate and attach cover to power box.

NOTE: FOR 380 AND 440 VOLTAGE ONLY

The power box is wired at the factory for use with 220 volt power supply. For use with other voltages the following changes are required.

For 380 volt supply remove the black/white wire from (F-1) and attach the purple wire (primary 380 V from transformer).

For 440 volt supply remove the black/white wire from (F-1) and attach the orange wire (primary 440 V from transformer).

FUSES FOR 220, 380 AND 440 VOLTS

Fuses must be installed according to the power supply. The following chart indicates the proper fuse and its location for the various voltages:

FUSES	220 V	380 V	440 V
F-1	670 F 38	670 F 34	670 F 34
F-2	670 F 38	670 F 34	670 F 34
F-3	670 F 35	670 F 40	670 F 34



MAKE CERTAIN POWER BOX IS WIRED CORRECTLY FOR THE VOLTAGE AT THE POWER SOURCE.

CAUTION!

- Connect power box to main power source.
- Turn main power switch to "ON" position.
- Check the direction of rotation of the motor pulley. When facing the pulley end of motor the rotation must be counterclockwise.

The machine pulley rotates clockwise.

If the rotation is in the opposite direction see instructions (Figs. 3 or 4).

AUTOMATIC CYCLING DEVICE KIT NO. 29480 RW

Kit No. 29480 RW is an optional item available that will automatically cycle the machine at pre-determined intervals.

NOTE: WHEN CYCLING DEVICE KIT NO. 29480 RW IS USED THE POWER BOX 29480 RT IS NOT REQUIRED.

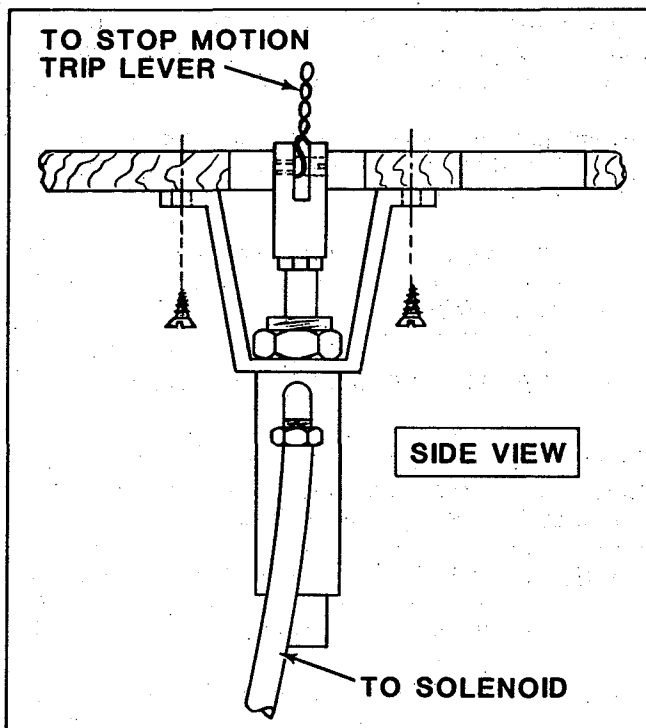

Fig. 8

INSTALLING CYCLING DEVICE

- Mount the power box to the right rear corner of the tableboard in the holes provided (See Fig. 5).
- Mount and assemble the air cylinder directly under the stop motion trip lever on the machine (Fig. 8) connect chain from cylinder to trip lever.
- Assemble air filter, regulator and solenoid valve as shown (Fig. 5). Set regulator so air pressure is 25 to 30 PSI.
- Assemble treadle (Fig. 9) and mount on the treadle rod as shown (Fig. 5). Note the treadle rod is located on rear of stand base approximately 6 inches (152.4 mm) up from floor. Adjust pedal height adjustment screw (Fig. 9) so operator is comfortable.

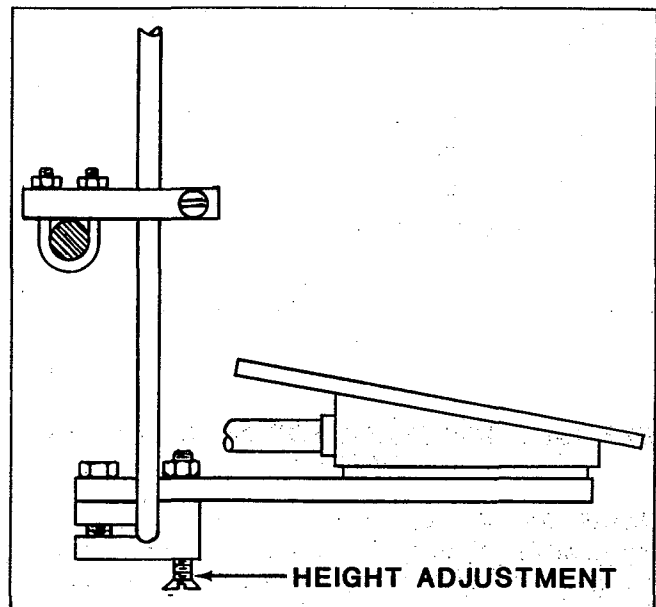

Fig. 9

INSTRUCTIONS FOR WIRING CYCLING DEVICE POWER BOX NO. 29480 RW



CAUTION!

DO NOT ASSEMBLE OR REMOVE COVER WITHOUT DISCONNECTING ELECTRICAL SUPPLY.

Use wiring diagram (Fig. 10) for reference when making the following connections. Connect the incoming power lead to the upper three terminals of the power switch. Connect the ground (green) lead to the brass grounding screw. Connect the motor leads to the side tabs of the fuse holders with ground to the same brass grounding screw. Connect the motor leads as explained in Figs. 3 and 4.

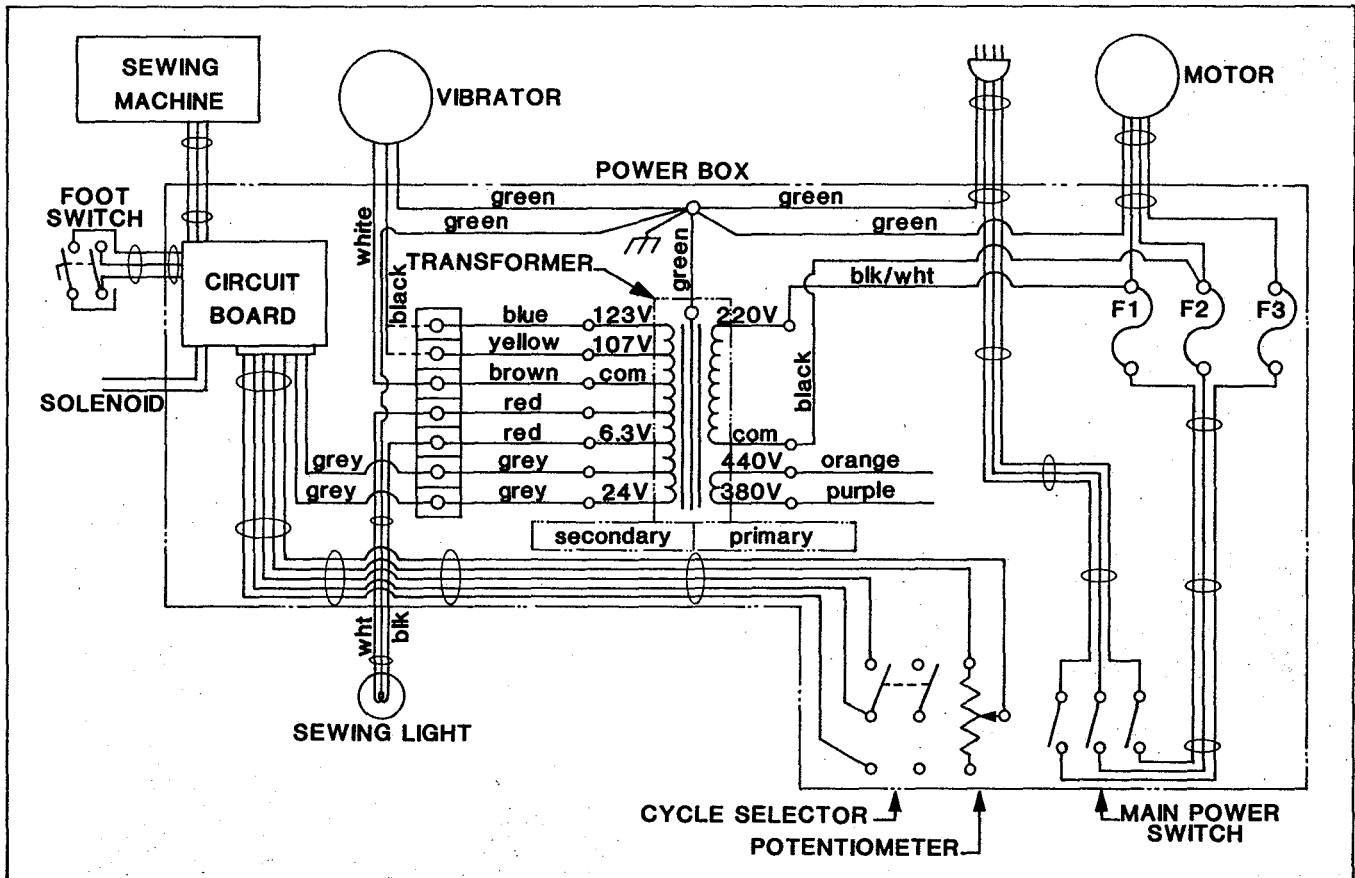

Fig. 10

**VIBRATOR CONNECTIONS FOR
220, 380 AND 440 VOLTS**

MEASURE LINE VOLTAGE then connect the two wires (black and white) from the vibrator to the barrier strip opposite the wires from the transformer as indicated:

Supply Voltage	Secondary Transformer Wires
220 V or less.....	Brown and Blue
220 V or more.....	Brown and Yellow
380 V or less.....	Brown and Blue
380 V or more.....	Brown and Yellow
440 V or less.....	Brown and Blue
440 V or more.....	Brown and Yellow

Now connect the green wire from the vibrator to the brass grounding screw. Connect the leads for the sewing light to the barrier strip opposite the two red wires from the transformer. Plug all leads into circuit board. Assemble rubber grommets into the grooves in the cable plate and attach cover to power box.

NOTE: FOR 380 AND 440 VOLTAGE ONLY

The power box is wired at the factory for use with 220 volt power supply. For use with other voltages the following changes are required.

For 380 volt supply remove the black/white wire from (F-1) and attach the purple wire (primary 380 V from transformer).

For 440 volt supply remove the black/white wire from (F-1) and attach the orange wire (primary 440 V from transformer).

FUSES FOR 220, 380 AND 440 VOLTS

Fuses must be installed according to the power supply. The following chart indicates the proper fuse and its location for the various voltages:

FUSES	220 V	380 V	440 V
F-1	670 F 38	670 F 34	670 F 34
F-2	670 F 38	670 F 34	670 F 34
F-3	670 F 35	670 F 40	670 F 34



MAKE CERTAIN POWER BOX IS WIRED CORRECTLY FOR THE VOLTAGE AT THE POWER SOURCE.

CAUTION!

VANE SWITCH

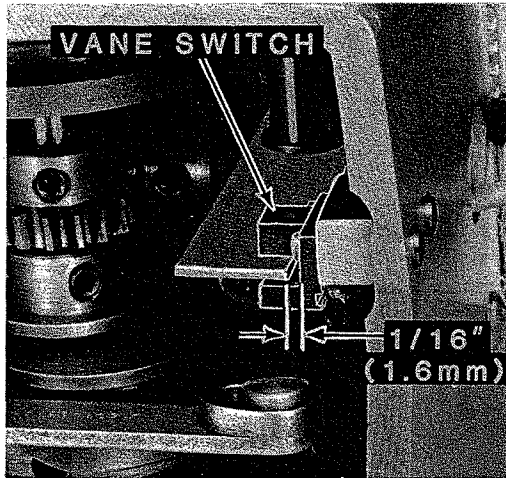

Fig. 11

The vane switch is part of the time delay circuit. Its purpose is to signal the timing components that a new cycle should begin. The movable vane blade is fixed to the stop motion lever shaft and will move out of the switch gap as the machine begins to sew. Upon completion of the stitching cycle the machine returns to stop position and the blade again enters the gap causing a signal to go to the timing components that a new cycle should begin. This circuit is energized only when the treadle switch is in the operate position. The vane switch is properly adjusted when the machine is in stop position, the blade is located in the center of the gap and the edge of the blade is positioned 1/16 inch (1.6 mm) from the end of the gap (Fig. 11). To adjust the vane blade loosen the set screw and position as described above, tighten set screw securely.

After completing the vane switch adjustments proceed as indicated below:

- Connect power box to main power source.
- Turn main power switch to "ON" position.
- Check the direction of rotation of the motor pulley. When facing the pulley end of motor the rotation must be counterclockwise.

The machine pulley rotates clockwise.

If the rotation is in the opposite direction see instructions on motor (Figs. 3 and 4).

ADJUSTING BUTTON VIBRATOR BOWL

Fill bowl with buttons—the buttons used initially should be the same as the sample buttons which were submitted when the machine was ordered. The machine was sewn off at the factory with the sample button submitted.

IF BUTTON REQUIREMENTS HAVE CHANGED AND ANOTHER SIZE OR TYPE OF BUTTON IS USED SEE PROCEDURE FOR CHANGING SIZE OF BUTTONS CONTAINED IN THE MACHINE ADJUSTING INSTRUCTIONS SECTION OF CATALOG.

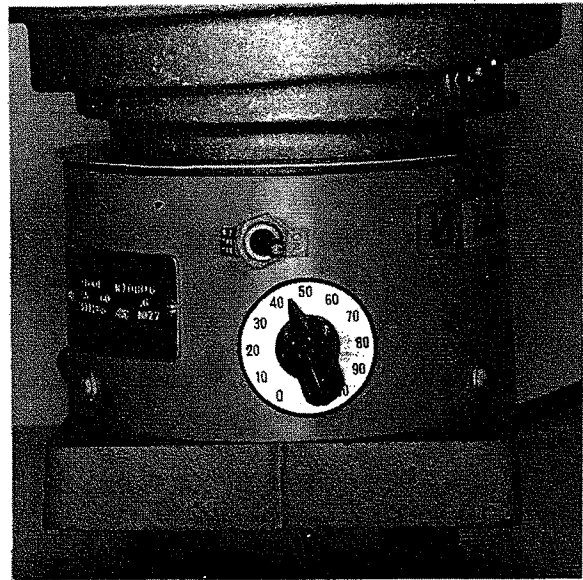

Fig. 12

Turn vibrator power switch to "ON" position and set the vibrator speed so that buttons feed up the track. Set initial vibrator speed at 40 to 60 on calibrated dial (Fig. 12).



Fig. 13

Set button wiper strips to correct height so that only one button will pass under (A, Fig. 13).

Adjust width of button track by turning thumbscrew (B, Fig. 13), until buttons that are wrong side up will drop off track. Point (C) must be set up from track to allow buttons to pass.

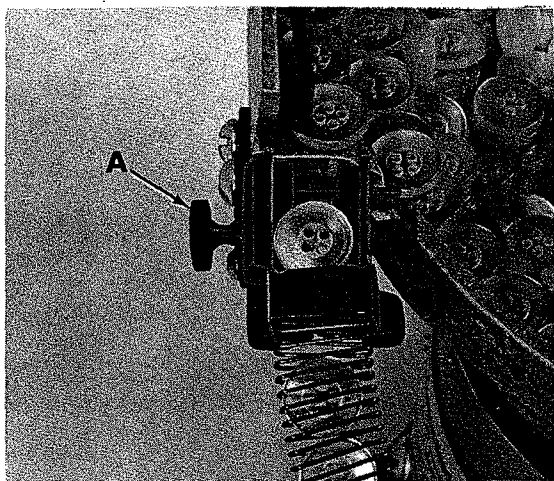

Fig. 14

Buttons should enter upper guide track one at a time. If the opening is too wide buttons will jam. Turn screw (A, Fig. 14) to make this adjustment.

CHECK BUTTON ORIENTATION

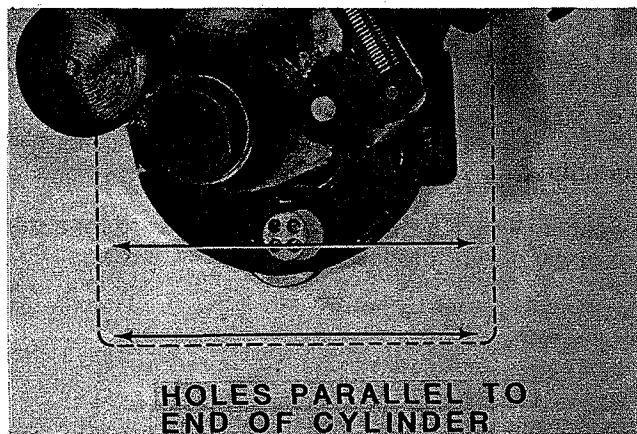

Fig. 15

Before operating the machine check to see if the button holes are located from left to right approximately parallel with end of the cylinder (Fig. 15). To make this check remove the needle and cycle the machine several times. Note the position of the holes and be certain that the needle will penetrate the holes without striking the button.

To check button alignment further use the following procedure:

TURN MAIN POWER OFF

Put a new needle in the needle bar, make sure needle is all the way up with the scarf of needle to the rear.

Engage machine into run position and rotate the machine pulley in operating direction watching the needle as it penetrates each button hole. Should the needle strike the button or not penetrate the center of the hole further clamp adjustment is required. See section in machine adjusting instructions under **BUTTON ALIGNMENT**.

OPERATING MACHINE

If all the previous instructions are successfully completed the machine is now ready for operation.

OPERATION OF STYLE 200-38 FITTED WITH CYCLING DEVICE NO. 29480 RW

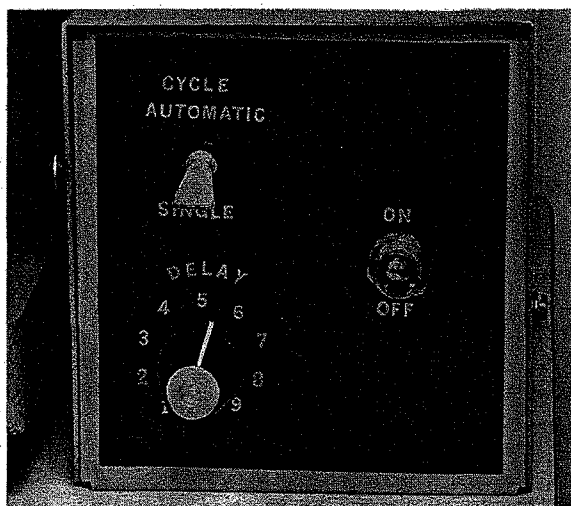

Fig. 16

To operate machines with cycling device (See Fig. 16) follow the procedure listed below:

1. Turn main power switch to "ON" position.
2. Set cycle switch to automatic mode.
3. Set cycle delay to INITIAL POSITION OF 5 TO 6.
4. While operator runs the machine set the cycle delay to correspond to the operator's ability.
5. For single cycling operation set cycle switch to single mode.

ADJUSTING INSTRUCTIONS FOR STYLES 200-38 AND 200-45



CAUTION!

The main power switch must be in the "OFF" position while making the following adjustments. Failure to comply may result in serious personal injury.

NOTE: Instructions stating direction or location such as right, left, front or rear of the machine are given relative to the operator's position at the machine.

STITCHING CYCLE

The stitching cycle for Class 200 machines is automatic. To start—press the operating treadle firmly downward, then release. The cycle will be repeated should the treadle remain in the down position.

The cycling mechanism consists of the stop motion plunger assembly, clutch assembly (Fig. 17), and the stop motion cam assembly (Fig. 19).

When the operating treadle is pressed downward the plunger assembly tilts moving the plunger head upward so that it releases the stop motion disc. Lever (B, Fig. 17) now presses the idler pulley against the clutch transferring the rotary motion to the shaft. During the stitching cycle, the stop motion cam (D, Fig. 19) holds the stop motion plunger and clutch in this position by means of a roller and lever affixed to the same shaft as the stop motion plunger assembly. At the completion of the cycle the roller drops into a recess in the cam (D, Fig. 19) allowing the clutch to disengage and the stop motion plunger to contact the vertical face of the stop motion disc. The cycle is now complete and the machine is in STOP POSITION.

Figure 17 shows the machine in STOP POSITION. Note that the vertical face of the stop motion disc (J) is in contact with the plunger (E). The following instructions refer to the machine in STOP POSITION so it is important to understand the term.

To operate the machine manually depress the operating treadle and rotate the pulley and clutch assembly in operating direction two complete revolutions so the stop motion plunger remains up.

NOTE: Grasping the knurled pulley on the left side of machine with the left hand and the clutch disc with the right hand allows rotating the shaft with minimum effort.

CLUTCH

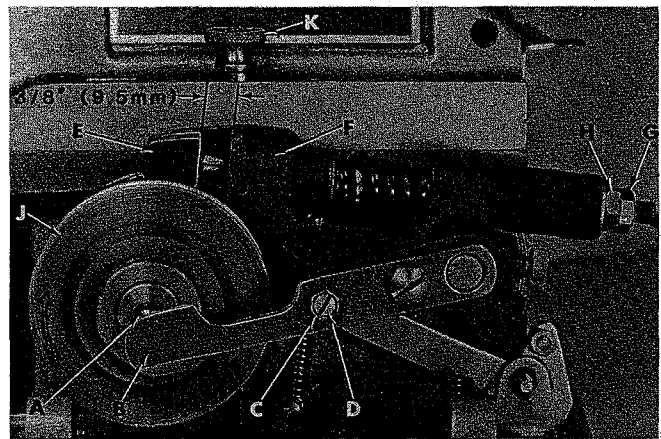

Fig. 17

Check:

Machine is in STOP POSITION. Push idler pulley in so that it contacts the clutch. There should be 1/32 inch (0.8 mm) clearance between the ball (A, Fig. 17) and lever (B).

Procedure:

Loosen locknut (C) and turn screw (D) inward for more clearance or out for less. Tighten locknut (C).

STOP MOTION PLUNGER

Check:

Machine is in STOP POSITION. Plunger head (E, Fig. 17) extends 3/8 inch (9.5 mm) from bracket (F).

Procedure:

Loosen locknut (G) and turn adjusting nut (H) to obtain correct dimension. Tighten locknut (G).

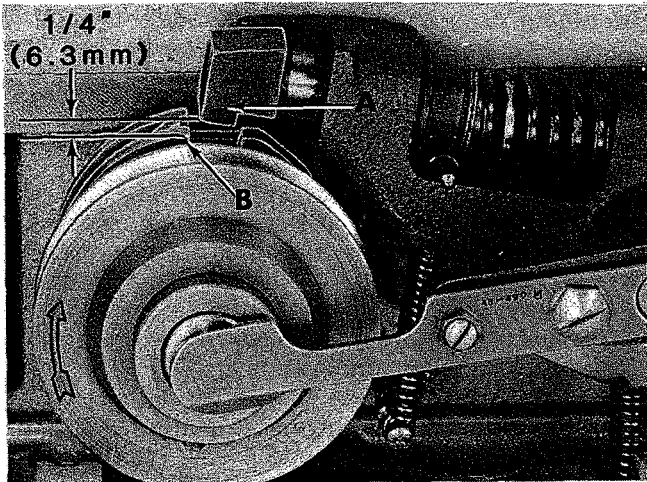

Fig. 18

Check:

Depress the treadle to engage machine into RUN POSITION. Rotate the pulley two complete revolutions in operating direction, then release the treadle. Measure the distance from the plunger head (A, Fig. 18) to the upper edge of the vertical face on the clutch disc (B). This distance should be 1/4 inch (6.3 mm).

Procedure:

Loosen clamp screw (A, Fig. 19) for the stop motion trip lever. Hold the lever down firmly so that roller (B) is against the cam then move the plunger (A, Fig. 18) up or down to the correct dimension. Tighten clamp screw (A, Fig. 19) securely.

NOTE: Maintain thrust on the shaft so that both the plunger assembly and the stop motion trip lever are against the bed casting without any end play.

NOTE: After this adjustment is completed, it is necessary to again check the clutch setting.

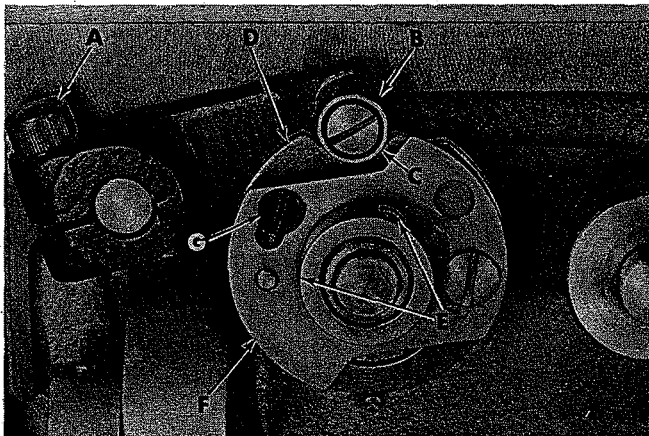

Fig. 19

STOP MOTION—PAWL AND LATCH

As the machine goes into STOP POSITION, the vertical face of the stop motion disc strikes the plunger head with considerable force. This impact tilts the pawl which in turn lifts the front edge of the latch to engage the extension on the plunger head. This action secures the stop motion disc, locking the machine in proper position ready for the next cycle.

NOTE: EXCESSIVE WEAR TO THE CONTACT SURFACE OF THE PLUNGER HEAD EXTENSION AND LATCH OR PAWL WILL CAUSE THE STOP MOTION TO MALFUNCTION. WORN PARTS MUST BE REPLACED.

STOP MOTION CAM (INNER CAM)

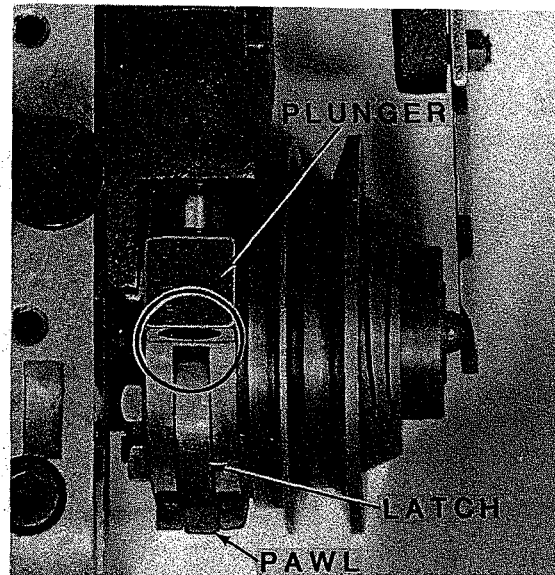

Fig. 20

Check:

Machine is in STOP POSITION. Rotate the stop motion disc in the reverse direction so that the vertical face moves away from the plunger head, approximately 1/4 revolution. Stop at a point where the plunger head is located at the edge of the cut-out for the pawl (See Fig. 20). The plunger head should now be in contact with the stop motion disc. The right stop motion cam (D, Fig. 19) should be in position so that the front of the recess on the cam is touching the roller at point (C).

Procedure:

Loosen set screws (E, Fig. 19). With the plunger head positioned as described in "Check", rotate the cam in operating direction so the front edge of the recess contacts the roller. Tighten screws (E).

SOFT STOP CAM (OUTER CAM)

Check:

Machine is in STOP POSITION. Cam (F, Fig. 19) is set at the factory so the roller will drop into the recess at the earliest possible time relative to the stop motion cam (inner cam) setting. Should the impact noise of the machine stopping increase after considerable use, the soft stop cam requires adjustment.

Procedure:

Loosen screws (E, Fig. 19) and screw (G). Slightly advance the outer cam (F) by rotating clockwise. Tighten screw (G). Now repeat the stop motion cam (inner cam) adjustments, described earlier.

NOTE: It may be necessary to repeat this procedure until the impact noise is minimized.

The clamp drive cams (A, Fig. 21) are set properly when the white timing marks on both cams align with the timing pins in the bed at points (B) and (C).

Procedure:

Engage the machine into RUN POSITION by pressing down firmly on the rear of the stop motion plunger assembly and rotate the pulley three complete revolutions in operating direction. The second set of screws for the cams should now be accessible. Loosen both set screws then rotate the pulley in the reverse direction until the machine again rests in STOP POSITION. Loosen the remaining set screws for both cams (D, Fig. 21), and align the timing marks on the cams to the timing pins in the machine bed. Tighten both screws (D). Again engage the machine into RUN POSITION and rotate the pulley three revolutions until the second set of screws are accessible. Tighten these screws and return the machine to STOP POSITION by rotating the pulley in the reverse direction.

CLAMP DRIVE CAMS

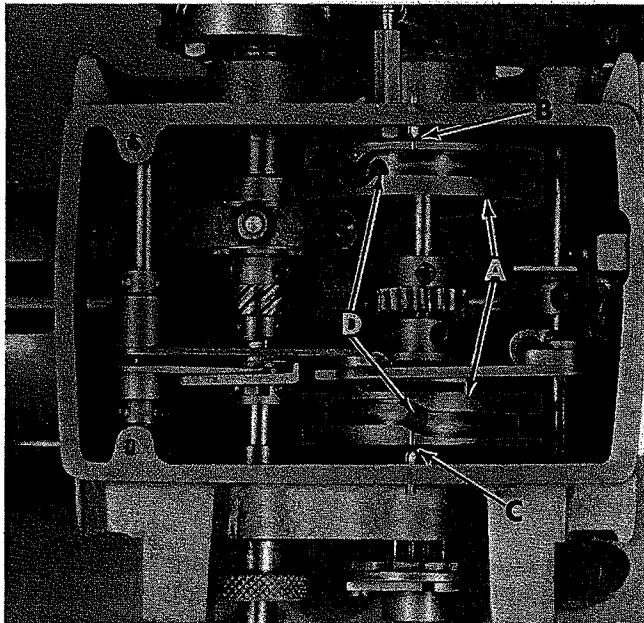

Fig. 21

Check:

Machine is in STOP POSITION. For reference, at this time the needle bar should have reached the top of its stroke and descended approximately 1/4 inch (6.3 mm). To complete this check it becomes necessary to lay the upper machine section on its side. Remove belt, loosen the knurled thumbscrew (K, Fig. 17) and tilt the machine on its side.

NOTE: On Style 200-38 remove the button chute before tilting the machine on its side.

CLAMP LIFTING LINK

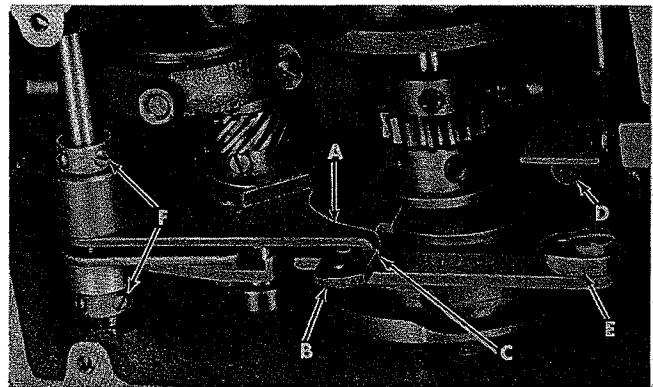

Fig. 22

Check:

Machine is in STOP POSITION. On completion of the stitching cycle, the button clamp is lifted by the cam driven lift lever (A, Fig. 22) and link (B). The link moves in to engage the lever as the stop motion plunger drops into stop position. Improper adjustments may cause the machine to repeat the stitching cycle or effect the clamp lifting.

Procedure:

Manually operate the machine and observe lever (A, Fig. 22) and link (B) while approaching the STOP POSITION. The lip of lever (A) must pass the leading edge of the notch point (C) in link (B) with minimum clearance and seat evenly in the notch without interference. Adjust link (B) by loosening screw (D) and move lever (E) on the shaft. To position lever (A) loosen the set screws in collars (F).

SETTING THE NUMBER OF STITCHES

Style 200-38 produces 16 stitches only on two or four hole buttons.

Style 200-45 produces 16 stitches on two or four hole buttons and can be set to complete only half of the cycle producing 8 stitches on two hole buttons only.

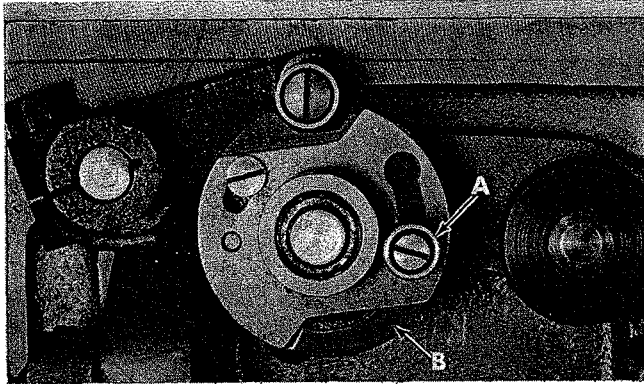
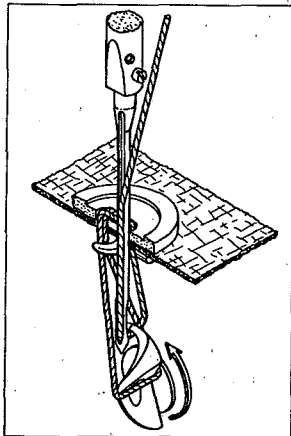

Fig. 23

Figure 23 shows Style 200-45 in STOP POSITION and set to produce 16 stitches. The stitch selector knob (A) is at its low position and the gap (B) is closed. To produce 8 stitches pull the knob (A) out and move it to the top of the slot. This will open gap (B) causing the machine to stop in the middle of the normal cycle.

NOTE: After making the setting above, position the selector lever at the rear of the machine for TWO HOLE buttons.

STITCH FORMATION



Class 200 machines produce the single thread chain stitch type 101. The stitch is formed by pushing a loop of needle thread through the fabric and holding it open below the fabric until the next loop passes through.

NEEDLE BAR

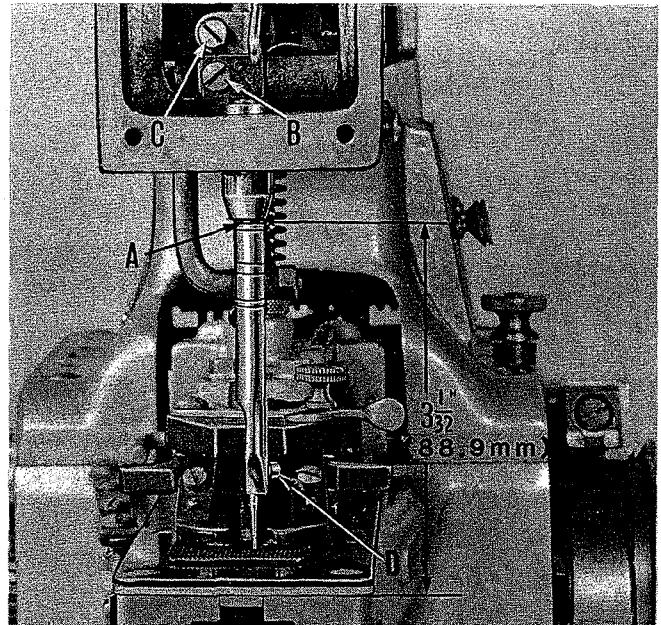

Fig. 24

Check:

Engage machine into RUN POSITION and rotate the pulley two complete revolutions in operating direction. Stop with the needle bar in its lowest position. The upper line of a pair of timing lines should be even with the lower edge of needle bar bushing (A, Fig. 24). The pair of timing lines used must correspond to the length of the needle used as follows:

SHORT NEEDLE..... UPPER PAIR OF LINES
 LONG NEEDLE..... MIDDLE PAIR OF LINES
 EXTRA LONG NEEDLE... LOWER PAIR OF LINES

Procedure:

Loosen clamp screws (B) and (C), then move the needle bar up or down to align the timing line with the bushing as explained above. Tighten screws securely. The needle bar thread guide should rest against the needle bar clamp. With the needle bar at its highest position the needle clamp screw (D) must clear the slot in the bushing.

NOTE: The height of the bushing is set to a gauge at the factory. The bottom edge is located 3 1/2 inches (88.9 mm) from the machined surface of the cylinder base.

LOOP POSITIONING FINGER

NOTE: BEFORE MAKING THE FOLLOWING ADJUSTMENTS INSERT A NEW NEEDLE AND REMOVE THE FEED PLATE.

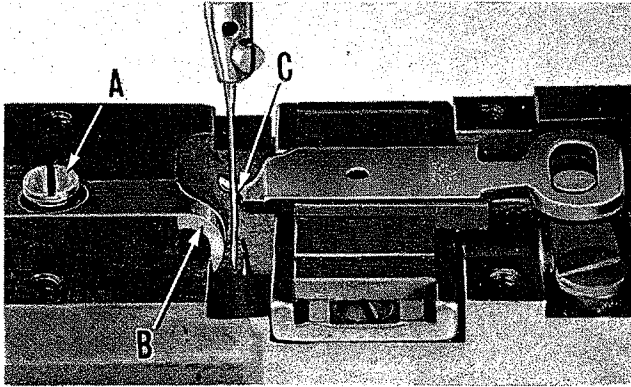

Fig. 25

Check:

Move the needle guard (B, Fig. 25) away from the needle by loosening screw (A), and sliding the guard forward. Engage machine into RUN POSITION and rotate the pulley two complete revolutions in operating direction. Continue rotation until the needle bar reaches its lowest position.

At this point the leading edge of the positioning finger (C, Fig. 25) should be approximately .002 inch (.05 mm) from the needle.

NOTE: Pull the positioning finger forward to remove end play while making this check.

Procedure:

Tilt the machine on its side. Loosen set screws (A, Fig. 26) in sleeve (B) and slide forward slightly. Temporarily tighten one of screws (A). Loosen screws (C) in cam (D) and slide the cam to the front or rear to locate the positioning finger to the needle as described in the check above. Tighten screws (C). Now move sleeve (B) back so that it contacts cam (D). Tighten screws (A) securely.

NOTE: Cam (D) moves the positioning finger to and from the needle. Cam (F) moves the finger laterally to hold the thread loop open for the descending needle to enter. BOTH CAMS MUST BE TIMED TO THE LOOPER. After completing the looper adjustment, it is necessary to then align the timing marks on both cams (D and F) to the adjacent timing marks on the looper adjusting sleeve (B).

LOOPER TIMING

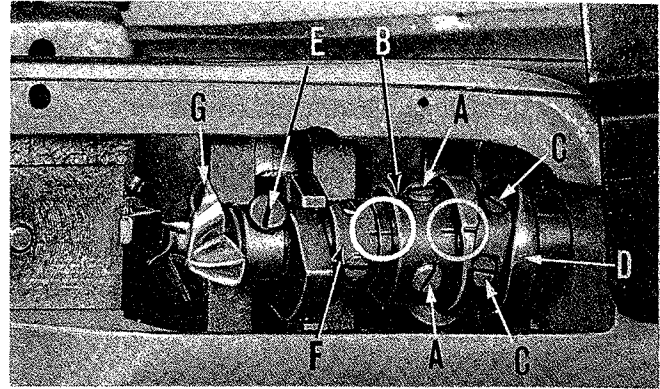

Fig. 26

Check:

Engage the machine into RUN POSITION and rotate the pulley two complete revolutions. Continue rotation until the needle bar reaches its lowest position. The top timing line of a pair of lines on the bar should now align with the bottom of the bushing. Again rotate the pulley slightly so that the second timing line is aligned with the bottom of the bushing. The point of the looper (G) should now be located at the center of the needle on its backside with approximately .002 inch (.05 mm) clearance to the needle.

NOTE: See NEEDLE BAR adjustments to determine which pair of timing lines to use.

Procedure:

Loosen screws (A) on sleeve (B) and rotate the sleeve so that the point of the looper is at the center of the needle. Push sleeve (B) against cam (D) and tighten screws (A). Now loosen clamp screw (E) on the looper collar and position the looper point .002 inch (.05 mm) from the needle. Tighten screw (E).

NOTE: The loop positioning finger cams may now need to be realigned to the timing marks on sleeve (B).

NEEDLE GUARD

Check:

When the needle bar is at its lowest position, the guard (B, Fig. 25) should be .002 inch (.05 mm) from the needle.

Procedure:

With the needle bar at its lowest position loosen screw (A, Fig. 25) and move the guard so that it is located .002 inch (.05 mm) from the needle. Tighten screw (A) securely.

FEED PLATE

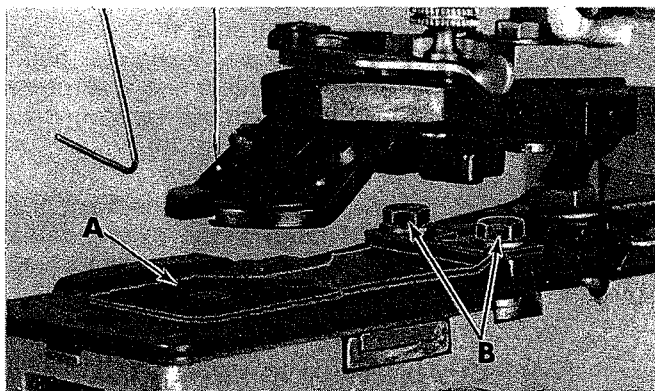

Fig. 27

Check:

The feed plate (A, Fig. 27) should be located so that it will not interfere with the needle at any point of its travel.

Procedure:

Loosen the two screws (B, Fig. 27) and move plate to the desired position. Tighten screws (B). This adjustment should be made while manually rotating the pulley so that the machine completes a full stitching cycle. The selector lever at the rear of the machine should be in the Four Hole Button position.

THREAD TENSION

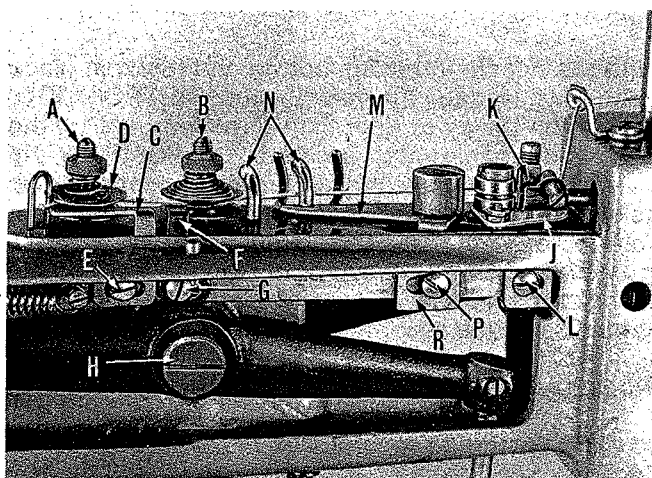

Fig. 28

The main thread tension (A, Fig. 28) located behind the automatic tension (B) determines how tight the button is sewn. The amount of tension applied to the thread will vary relative to the type of thread, material and the thickness of the button used. Normally, only a light tension is required.

TENSION RELEASE LEVERS

Check:

Thread the machine according to the Threading Diagram. Engage the machine into RUN POSITION and rotate the pulley two complete revolutions in operating direction. The tension release lever (C, Fig. 28) should be located as close as possible to the tension discs (D) of the main tension assembly (A) without making contact.

Procedure:

Loosen screw (E) and move lever (C) in the required direction. Tighten screw (E).

NOTE: The tension release lever (F) for the automatic tension is adjusted in a similar manner by loosening screw (G).

THREAD NIPPER

The thread nipper (J, Fig. 28) should pinch and hold the thread tight while it is being cut.

Check:

Engage the machine into RUN POSITION. There should now be $3/64$ inch (1.2 mm) clearance between the nipper and block (K).

Procedure:

Loosen screw (L) and move nipper (J) in the required direction. Tighten screw (L).

THREAD PULL-OFF LEVER

At the end of the stitching cycle, the thread pull-off lever (M, Fig. 28) should pull enough additional thread from the spool to form the first stitch of the next cycle.

Check:

Engage the machine into RUN POSITION and pull the thread taut against the thread guides (N, Fig. 28). The pull-off lever (M) should not contact the thread. Turn power "ON" and sew several buttons on scrap material. The pull-off lever is set correctly when a length of thread $1/4$ inch (6.3 mm) to $3/8$ inch (9.5 mm) remains on the underside of the fabric at the right hole of a two hole button; or the right rear hole of a four hole button.

Procedure:

The pull-off lever (M) is adjusted by loosening screw (P) and moving block (R). If the thread tail left was too long an excessive amount of thread is being pulled off, so move the lever to the right away from the thread. If the thread tail appears at the left hole of the button then the starting thread is too short causing the machine to miss the first stitch. If such is the case then move the pull-off lever to the left so it will pull off more thread.

AUTOMATIC THREAD TENSION

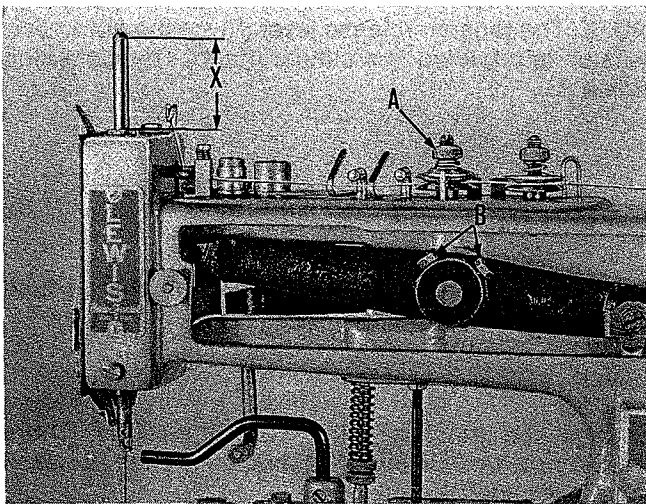

Fig. 29

The automatic thread tension controls how tight the stitch is pulled up on the underside of the fabric.

Check:

Turn the tension nut (A, Fig. 29) down four or five turns. The automatic tension should release the thread when the needle bar, on its upstroke, has risen so that the lower edge of the beveled top is DIMENSION "X" (Fig. 29) above the upper needle bar bushing. DIMENSION "X" is determined by the length of the needle used as follows:

NEEDLES USED	DIMENSION "X"
Short	1 5/16 inch (33.3 mm)
Long	1 11/16 inch (42.8 mm)
Extra Long	1 7/8 inch (47.6 mm)

Procedure:

Rotate the pulley in operating direction so that the needle bar has risen to correspond to the proper DIMENSION "X". Loosen the two hexagonal head screws (B, Fig. 29) in the needle lever hub and rotate the shaft (H, Fig. 28) until the upper tension disc begins to rise. Tighten screws (B, Fig. 29).

NOTE: This is an extremely important adjustment and should be re-checked. If large loops exist on the underside of the fabric apply more tension by turning nut (A, Fig. 29) down.

THREAD TRIMMING KNIVES

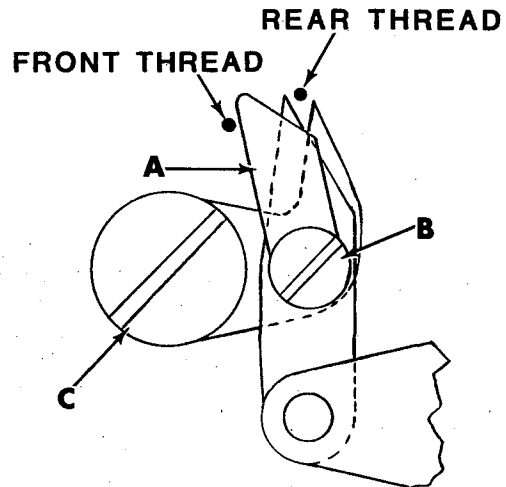

Fig. 30

Check:

With the needle threaded, button and fabric in place to be sewn, engage the machine into RUN POSITION. Rotate the pulley in operating direction until on the last needle penetration before STOP POSITION the clamp lift rod starts to move. Now, tilt the machine on its side, continue rotating the pulley and observe the knife movement. The thread separator (A, Fig. 30) must push the front thread of the loop forward so the knives do not touch it. The scissor action of the knives should sever the rear thread only.

Procedure:

To move the thread separator (A, Fig. 30) loosen screw (B). The knives can be positioned to the rear thread by loosening screw (C, Fig. 30) and moving knives to the front or rear as required. Tighten screw (C). The lateral position of the knives relative to the thread may be adjusted by loosening screws (A, Fig. 31) and moving the arm (B). Tighten screws (A).

NOTE: ON STYLE 200-38 DO NOT DISTURB THE ORIENTING PIN LIFTING LEVER WHEN MAKING THIS ADJUSTMENT

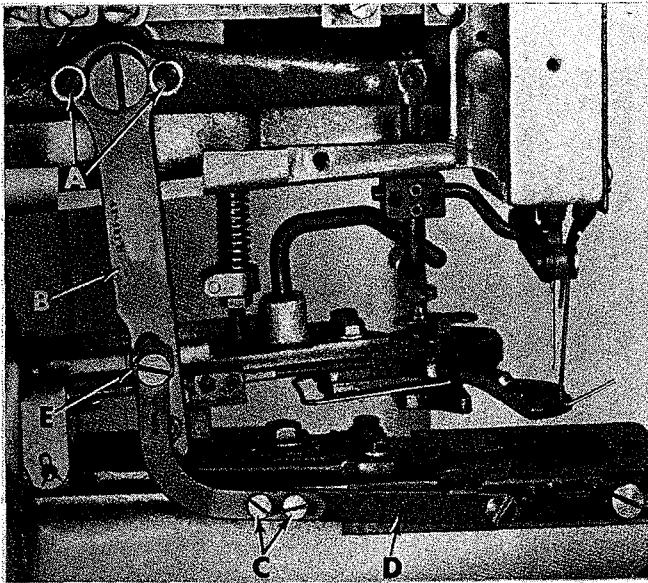

Fig. 31

Further lateral adjustment of the knives can be obtained by loosening screws (C) and moving link (D) in the slot. Tighten screws (C). To increase or decrease the distance knife travels loosen locknut (E, Fig. 31) and position the stud up or down in the slot. Moving the stud down will increase the travel.

SEWING TWO OR FOUR HOLE BUTTONS

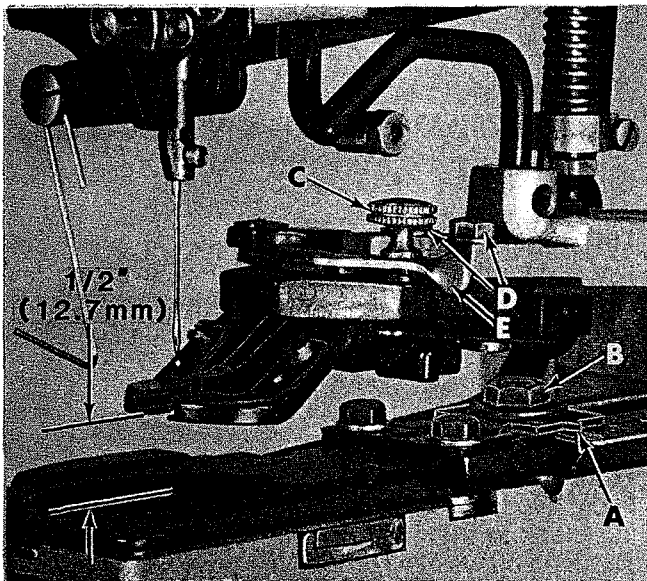

Fig. 32

TWO HOLE BUTTONS

Measure the distance between the two holes of the button (from center to center). Then set the indicator (A, Fig. 32) to corresponding dimension on the graduated scale by loosening nut (B). Move selector lever (A, Fig. 33) at rear of the machine to the two hole position (B).

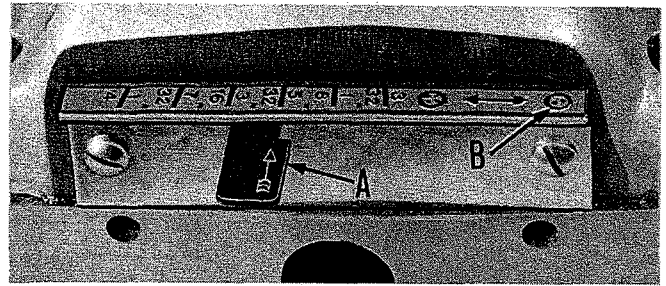
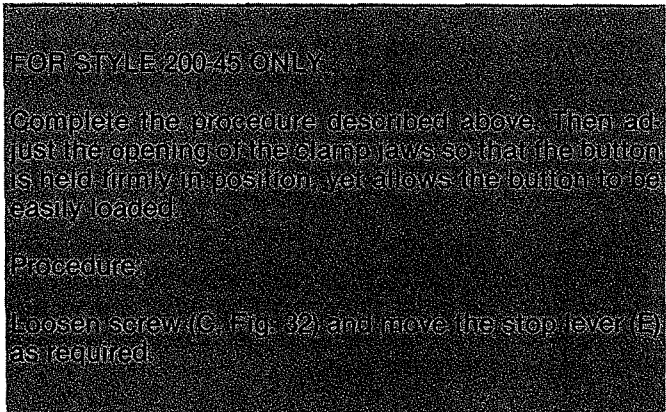

Fig. 33

FOUR HOLE BUTTONS

Repeat the procedure for the two hole button except move the selector lever (A, Fig. 33) at rear of machine to a dimension on the graduated scale corresponding to the distance between the button holes.

NOTE: The stitch can be tightened on buttons having large holes by decreasing the lateral clamp travel—set indicator (A, Fig. 32) to a smaller dimension on the graduated scale.



Now, place a button into the clamp jaws (200-45) or button holder (200-38) so that the button holes correspond to the needle travel across the arm. Engage the machine into RUN POSITION and rotate the pulley in operating direction until the needle has penetrated all the holes in the button. The needle should enter the center of each hole. The button clamp may be shifted slightly to obtain this condition by loosening screws (D, Fig. 32) on 200-45 or (E, Fig. 34) on 200-38. It may also be necessary to deviate slightly from the graduated scale dimensions previously used.

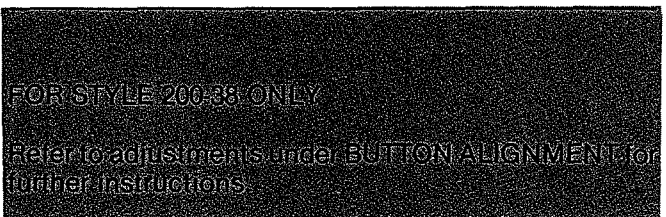

BUTTON CLAMP

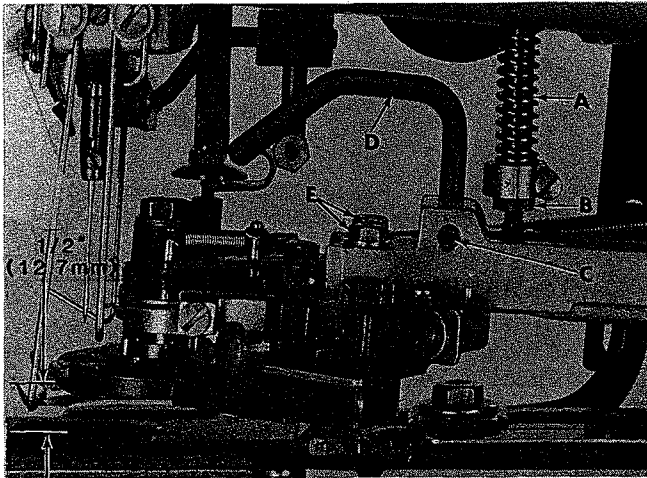

Fig. 34

CLAMP HEIGHT

Check:

Machine is in STOP POSITION. The button clamp or holder should be adjusted so that the bottom is approximately 1/2 inch (12.7 mm) from the feed plate, (See Figures 32 and 34).

Procedure:

Loosen set screw (C, Fig. 34) and raise or lower rod (D) as required. Now engage machine into RUN POSITION. The clamp in down position must contact the feed plate and there should be clearance between the lifting rod (D) and the roller.

CLAMP STOP PIN

The stop pin is located inside the clamp tension spring (A, Fig. 34).

Check:

Machine is in STOP POSITION and the clamp is raised. The stop pin is set correctly when the clamp can be lifted manually an additional 1/32 inch (0.8 mm).

Procedure:

Loosen locknut (B, Fig. 34) and turn the lower section to lengthen or shorten the pin. Tighten locknut (B).

CLAMP LIFTING LEVER STOP

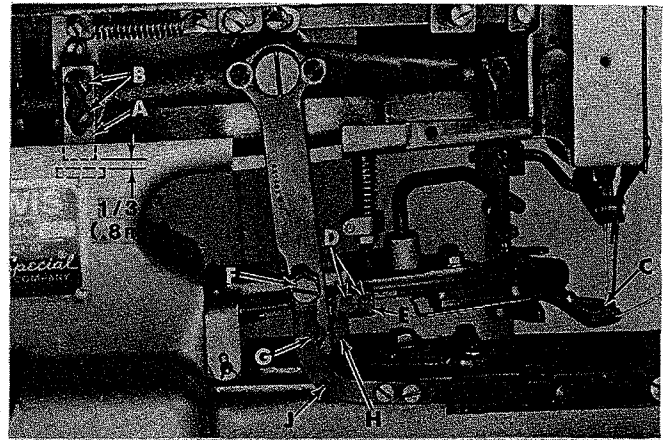

Fig. 35

Check:

Machine is in STOP POSITION and the clamp is raised. There should be 1/32 inch (0.8 mm) clearance from the bottom of the clamp lifting lever stop (A, Fig. 35) to the nipper bar bearing block. This can be checked by manually lifting the clamp lift lever and noting the travel until the stop contacts the bearing block.

Procedure:

Loosen the two screws (B, Fig. 35) securing the stop block and move the block up or down as needed. Tighten screws (B).

BUTTON CLAMP OPENER—STYLE 200-45 ONLY

Check:

The button clamp jaws (C, Fig. 35) should start to open just before the clamp begins to lift. The clamp jaws should then open to release the button and return to the clamping position when the clamp is completely raised.

Procedure:

To open the jaws earlier, loosen screws (D, Fig. 35) and move the front tripping block (E) to the rear. Moving block to the front will cause jaws to open later. Tighten screws (D). To close the jaws sooner, remove screw (F) securing the knife drive link arm, then loosen screw (G) and move tripping block (H) down. Raising block (H) will open the jaws wider for a longer duration. When the desired condition is obtained, retighten screw (G) and replace screw (F) securing the knife drive link arm (J).

NOTE: To disengage the clamp opener reposition the tripping blocks (E and H, Fig. 35) so they do not come in contact.

THE FOLLOWING INSTRUCTIONS APPLY ONLY TO THE AUTOMATIC BUTTON FEEDING COMPONENTS FOR STYLE 200-38

BUTTON POSITIONING SEQUENCE

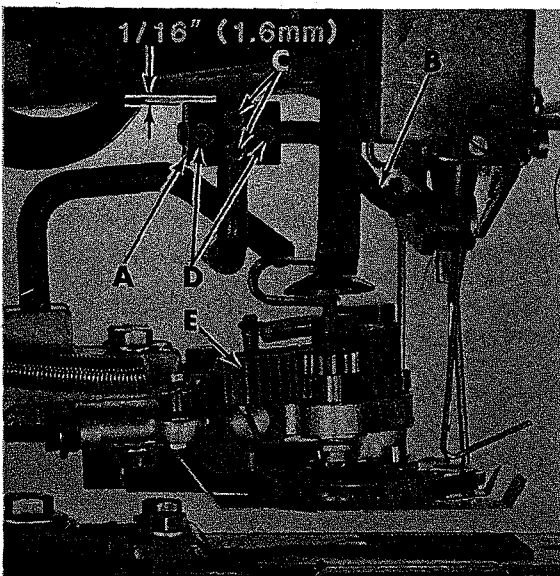

Fig. 36

Engage machine into RUN POSITION and rotate the pulley in operating direction three complete revolutions. At this time, the button positioning sequence begins as the gear rack drive cam starts to move the gear rack (E, Fig. 36) forward. Continue to rotate the pulley through a complete stitching cycle to observe the following sequence of component functions related to presenting the button in position to be stitched.

The button orienting pin (B, Fig. 37) now rests on the button. The gear rack moving forward rotates the orienting pin so that it finds and enters the holes in the button. It then continues rotating the button until the holes are in position to be stitched, after the button holder rotates.

In moving forward the gear rack also engages the gear clutch that will later rotate the button holder. The button holder does not turn on the forward stroke of the gear rack since the clutch assembly inside the gear clutch does not grip the button chuck shaft when turned in this direction. The stop pins on the button holder chuck also are blocked by escapement lever (C, Fig. 37).

Upon completion of the stitching cycle as the clamp begins to lift, the orienting pin is lifted up out of the button holes to completely clear the holder. As the clamp continues to rise, wire (D, Fig. 37) trips the release spring resulting in the escapement lever (C) moving away from the stop pin on button holder chuck.

The button holder is now rotated as the gear rack is forced to return to its original position by the spring attached. The clutch inside the gear barrel now grips the button holder chuck shaft, then rotates the button holder 120 degrees positioning the next button ready to be sewn.

NOTE: Unless specified to the contrary, all the following Checks and Procedures are to be performed with the machine in STOP POSITION.

THREAD WIPER

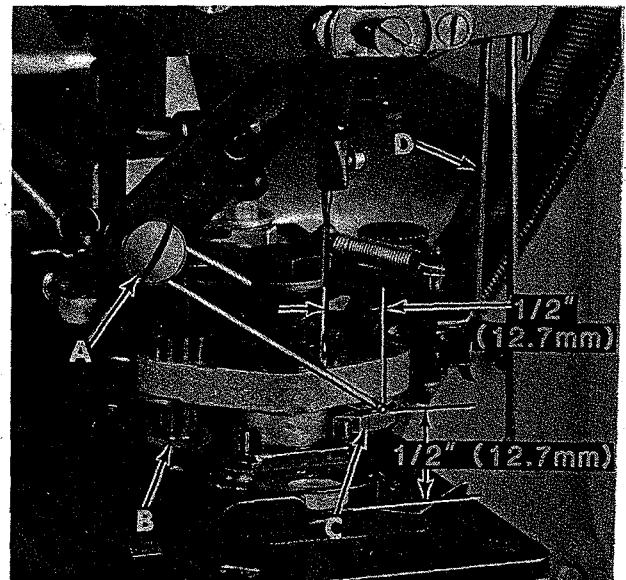

Fig. 37

Check:

Machine is in STOP POSITION and clamp is raised. Bracket (A, Fig. 36) should be 1/16 inch (1.6 mm) from the casting. Drive rod (B) viewed from the front, should be positioned so that the angled portion is vertical. It must not contact either end of the slot when wiper is at the left or right of the needle.

Engage the machine into RUN POSITION so that the clamp is down and the thread wiper is to the right of the needle. The thread wiper wire, at the bend, should now be located 1/2 inch (12.7 mm) to the right of the needle and 1/2 inch (12.7 mm) above the top cover (Figure 37).

Procedure:

Loosen screws (C, Fig. 36) and position bracket (A) to the required dimension. Tighten screws (C). Move drive rod (B) by loosening screws (D). With clamp down, position the wiper wire as described by loosening screw (A, Fig. 37). Tighten screws securely.

BUTTON HOLDER SPRINGS

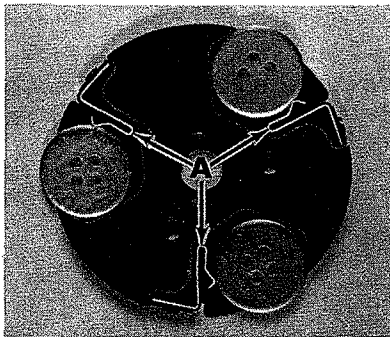

Fig. 38

Check:

Side pressure springs (A, Fig. 38) are set correctly when there is enough tension applied to hold the button in position as the holder rotates yet allows loading and removing the button easily.

Procedure:

Loosen hex head bolt (A, Fig. 39) and remove the button holder. Loosen screw (B) in the holder top cover. Insert three buttons, of the size to be sewn, in the holder. More or less spring pressure is applied to the buttons by slightly rotating the top cover while holding the bottom portion. When proper pressure is obtained, tighten screw (B) and assemble the holder to the clamp. Tighten hex head bolt (A).

NOTE: The button holder springs are set radially at the factory and should not be adjusted individually.

BUTTON GUIDING CAM

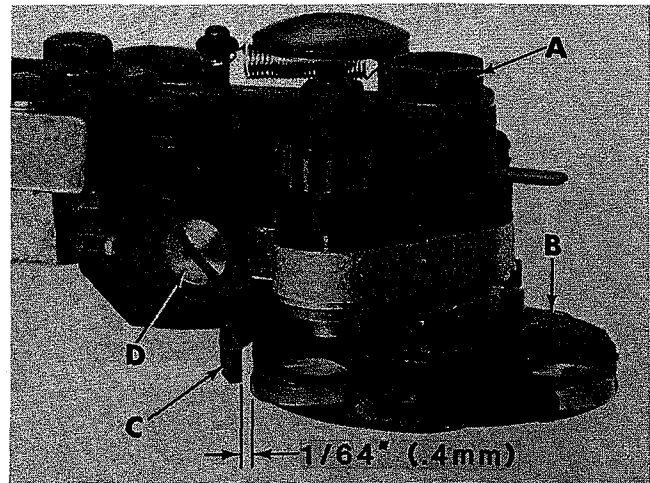

Fig. 39

Check:

With a button properly seated in the holder, guide (C, Fig. 39) should clear the button by 1/64 inch (0.4 mm) as the holder rotates.

Procedure:

Loosen screw (D) and position guide to proper dimension. Tighten screw (D).

GEAR RACK DRIVE CAM

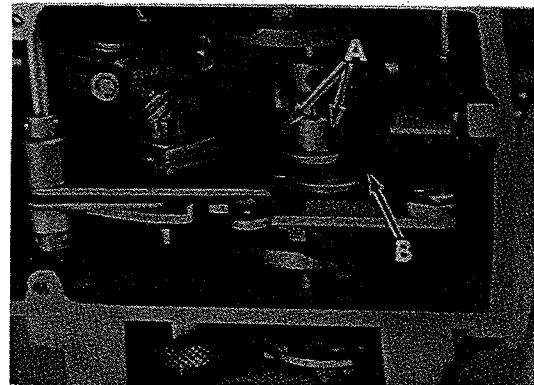

Fig. 40

Check:

Engage the machine into RUN POSITION and rotate pulley three complete revolutions. The gear rack (E, Fig. 41) should now start to move forward.

Procedure:

Lay the machine on its side and loosen the clamp screws (A, Fig. 40) in drive cam (B). Advance the cam until the gear rack just begins to move forward. Tighten the two screws (A).

GEAR RACK CONNECTING ROD

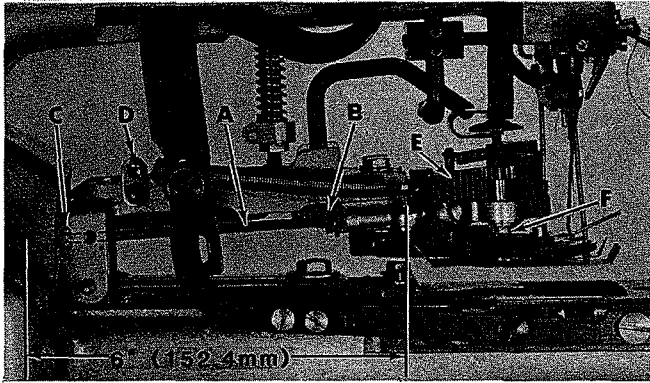

Fig. 41

Check:

The length of the connecting rod (A, Fig. 41) measured from the center of the front ball to the center of the rear ball should be 6 inches (152.4 mm). When sewing large diameter buttons having greater distances between the button holes the clamp travel is increased and may effect the connecting rod function. Should the gear rack travel too far forward and jam, then the length of the connecting rod must be shortened. If length of the rod is too short the escapement lever will not release the stop pin on the button holder and prevent the holder from rotating. Tension on the gear rack return spring should be enough to rotate the holder.

Procedure:

Loosen locknuts (B and C, Fig. 41) and rotate the connecting rod (A) so that the required dimension between the ball joints is obtained. Tighten locknuts (B and C). Adjust spring tension by positioning spring holder (D).

BUTTON ORIENTING PIN

Check:

The distance between the pins (F, Fig. 41) must match the holes in the button. On four hole buttons the pins should enter holes diagonally. If the pins do not correspond to the button holes the orienting pin must be replaced with one having the proper pin spacing.

NOTE: See BUTTON ALIGNMENT adjustments.

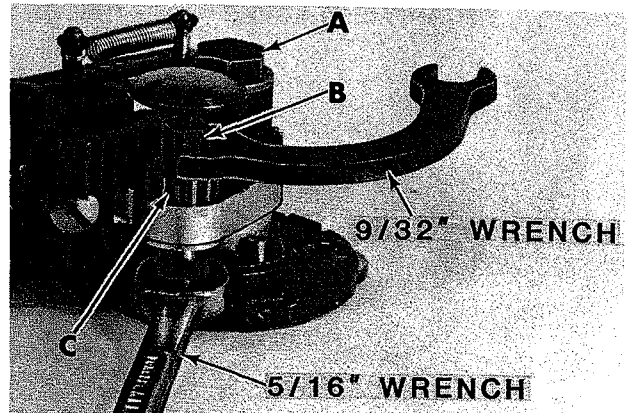

Fig. 42

Procedure:

Machine is in STOP POSITION. To replace the orienting pin, remove the button holder by loosening hex head bolt (A, Fig. 42). Now loosen and remove locknut (B) using a 9/32 inch open end wrench while holding the orienting base with a 5/16 inch wrench. Remove the orienting pin drive gear (C). The orienting pin can now be removed. Replace with the proper orienting pin by reversing procedure used to remove the other one.

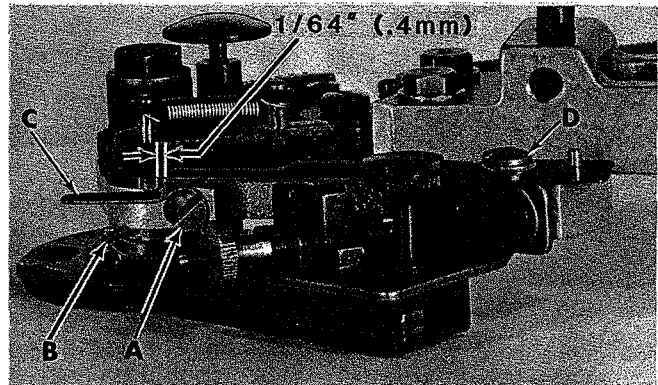

Fig. 43

Check:

Engage the machine into RUN POSITION. Rotate the orienting pin by manually moving connecting rod (A, Fig. 41) forward. The pins should drop into the button holes. If pins do not enter the button holes, the holder can be rotated slightly forward or to the rear so the button holes will align with pins.

Procedure:

Loosen screw (A, Fig. 43) on right side of clamp and rotate the cam with its pin (B) to make this adjustment.

ESCAPEMENT LEVER

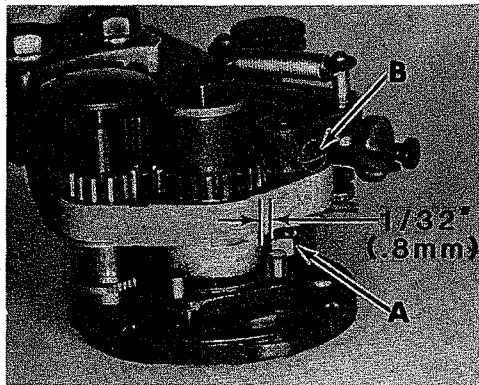

Fig. 44

The escapement lever (A, Fig. 44) functions as a stop for the button holder as it rotates 120 degrees each machine cycle. The lever must be adjusted to release the stop pins of the button holder allowing it to rotate.

Check:

There should be 1/32 inch (0.8 mm) clearance between the tip of the escapement lever and the clamp housing (Fig. 44).

Procedure:

Loosen screw (B, Fig. 44) located on the right side of the clamp and rotate the lever to the proper position. Remove end pin in shaft and tighten screw (B).

ESCAPEMENT LEVER RELEASE

Check:

Engage machine into RUN POSITION. The escapement lever release spring (C, Fig. 43) should be positioned front to rear so that there is 1/64 inch (0.4 mm) between the stop shoulder of the spring and the pin.

Procedure:

Loosen screw (D, Fig. 43) and move spring (C) to obtain proper dimension to pin. Tighten screw (D).

Check:

Machine is in STOP POSITION. Strike-off wire (A, Fig. 45) is set correctly when low enough to push release spring (B) down so that its shoulder clears the escapement lever pin (C) allowing the escapement lever to release the button holder. The tip of the wire should be positioned 1/8 inch (3.2 mm) from edge of the release spring.

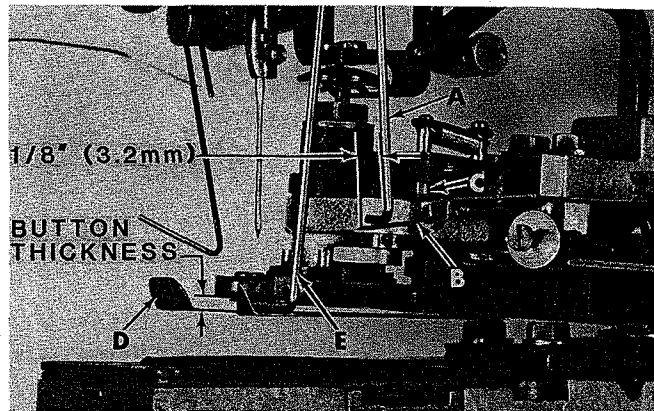

Fig. 45

Procedure:

Loosen clamp screw and move strike-off wire to position described in Check. Tighten clamp screw.

BUTTON ALIGNMENT

The orienting pin must rotate the button so that the button holes are in position for the needle to penetrate the center of each hole.

Check:

Remove the needle from the machine and operate machine under power for several cycles. Observe the location of the button holes as presented to the stitching position. The holes must be aligned left to right parallel to the front edge of the cylinder.

Procedure:

Turn power "OFF". Machine is in STOP POSITION. Loosen locknut (B, Fig. 42) with a 9/32 inch open end wrench while holding the orienting pin base with a 5/16 inch wrench. Now rotate the base in the direction needed to align the button holes to the needle, when the button is in position to be stitched. Tighten locknut (B) and operate the machine under POWER to again check position of the button holes. Repeat this procedure until the button holes are in the correct position relative to the needle. Now, replace needle and operate the machine manually through a complete cycle (POWER "OFF") observing the needle as it penetrates each hole. Further adjustment of the orienting pin may be required.

ORIENTING PIN LIFTER LEVER

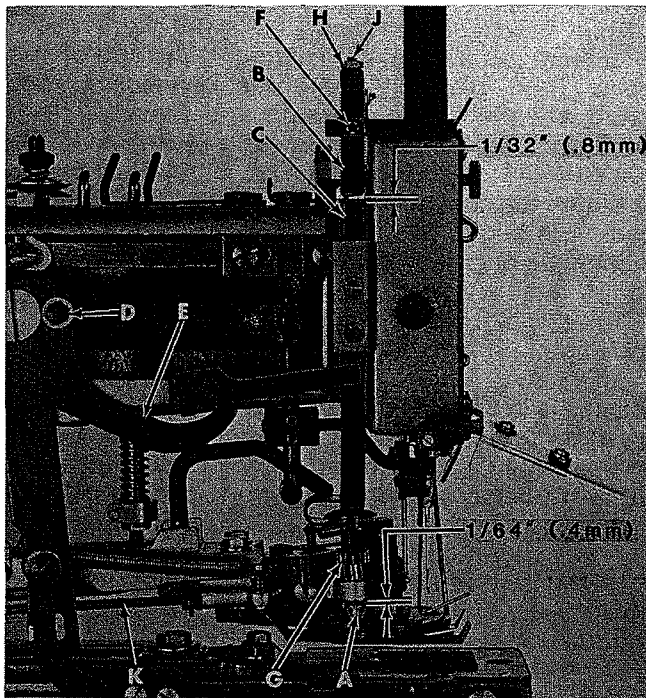

Fig. 46

Check:

Machine is in STOP POSITION. The top of orienting pin base (A, Fig. 46) must be 1/64 inch (0.4 mm) from bottom of bushing. The lifter lever stop (B) is adjusted so that there is 1/32 inch (0.8 mm) clearance between the bottom of stop (B) and bracket (C).

Procedure:

Loosen the two hex head screws (D, Fig. 46) and move the lifter lever (E) up or down as needed. Tighten screws (D).

NOTE: It is necessary to hold the knife drive arm in position while making this adjustment.

To set the lifter lever stop loosen locking screw (F) and rotate the knurled stop screw (B) in the direction required. Tighten locking screw (F).

ORIENTING PIN PRESSURE SPRING

Check:

Remove button from the holder at the orienting pin (A). Engage the machine into RUN POSITION. The driven gear (G, Fig. 46) of the orienting pin should now contact the top of the bushing with just enough pressure to push the pins into the button holes and not bounce out during the stitching cycle.

Procedure:

Loosen locknut (H) and turn screw (J) downward for more pressure or up for less. Tighten locknut (H).

BUTTON UNLOADING SPRING

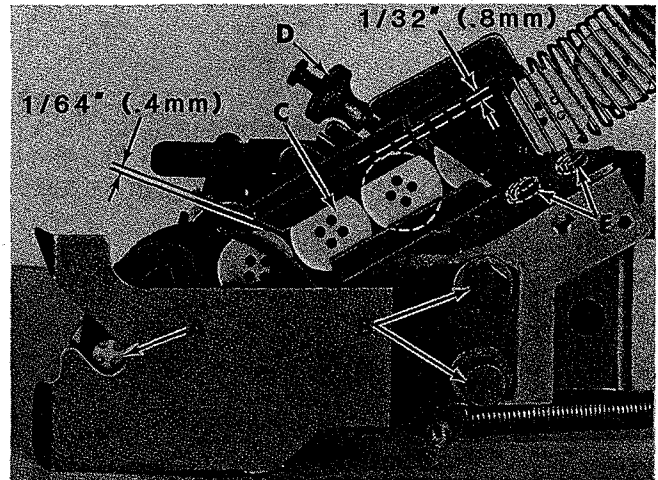

Fig. 47

Check:

The opening in the button unloading spring (A, Fig. 47) must be positioned so that the needle does not strike the spring during the stitching cycle.

Procedure:

Remove the button clamp assembly from the machine. With a button in position to be sewn, look through the holes of the button. The spring must not obstruct the holes. If adjustment is needed, loosen the two hex head screws (B) holding the spring on the underside of the clamp and move the spring as needed. Retighten the two screws securely. Then install the clamp assembly onto the machine.

Check:

Machine is in STOP POSITION. The button unloading spring (D, Fig. 45) should be held down by rod (E) so that the sewn button is removed from the holder. The distance between the unloading spring and the bottom of the holder should be approximately the thickness of the button used.

Procedure:

Loosen clamp screw and position rod (E) so that spring (D) is held down below the button holder the required dimension.

BUTTON GUIDE TRACK

Check:

The button track opening (C, Fig. 47) must correspond with the size of button used. When set correctly the track opening is 1/32 inch (0.8 mm) wider than the button.

Procedure:

Remove the button chute. Place a button in the track and rotate the thumbscrew (D, Fig. 47) so that the track opening is 1/32 inch (0.8 mm) wider than the button.

Check:

With buttons inserted, rotate the button holder manually. Observe the distance between the button and the leading edge of the guide track. The button must clear the guide track by 1/64 inch (0.4 mm).

Procedure:

Loosen screws (E) and position the guide track front to rear as required.

NOTE: Position the end of the guide track closest to the button holder slightly lower than the rear. The button holder spring must not prevent the button from entering the holder.

SAFETY STOP

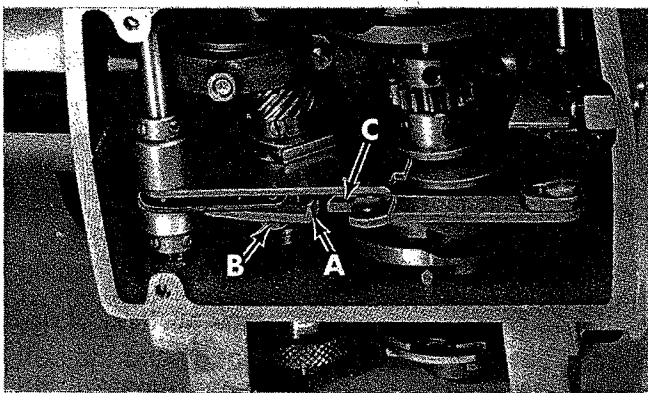

Fig. 48

The function of the safety stop (A, Fig. 48) is to prevent engaging the machine into RUN POSITION should the button holder fail to place the button at the proper sewing position.

Check:

Machine is in STOP POSITION. Remove the needle and turn power "ON". Manually move the gear rack connecting rod (K, Fig. 46) forward to the end of its stroke. Then gradually move the connecting rod toward the rear while pressing and releasing the operating treadle several times. KEEP FINGERS AWAY FROM UNDERNEATH THE CLAMP. Observe the button moving into sewing position. The machine should not begin its stitching cycle until the button reaches the proper sewing position.

Procedure:

Machine is in STOP POSITION and a button is in position to be sewn. Tilt the machine on its side. Loosen hex head bolt (B, Fig. 48) and position safety stop (A) so that its leading (stepped) edge is slightly to the front of link (C) as shown.

When a button is in sewing position safety stop (A) should allow link (C) to move to the left without interference.

If a button is not in proper position to be sewn then safety stop (A) should block movement of link (C) preventing the machine from being engaged into run position.

Repeat the instructions given in Check to insure proper function.

PROCEDURE FOR CHANGING SIZE OF BUTTONS

When it becomes necessary to adjust the machine to accommodate buttons having a different size, the following procedure is suggested:

- Remove all buttons from the vibrating bowl through the opening located at the lower front of the bowl.
- Disconnect the button chute at the clamp and remove the buttons from the chute and the button holder.
- Now fill the bowl with the new buttons. The bowl should be filled with buttons up to the lower wiper strip ramp.
- Turn the vibrator power switch to "ON" position. Set the vibrator speed so that the buttons feed slowly up the track (40 to 60 on the calibrated dial).
- Set the button wiper strips in the bowl so that only one button will pass under at a time.

- Adjust the width of the upper button track by turning the thumbscrew until buttons turned with the concave side down fall off the track.
- Set the upper guide track on the bowl so that the opening is 1/32 inch (0.8 mm) wider than the button used.
- Adjust the lower guide track on the clamp so the opening is 1/32 inch (0.8 mm) wider than the button.
- The side pressure springs in the button holder are to be set so that the buttons are held in place as the holder rotates.
- Now follow the checks that are explained under the section in the "Adjusting Instructions" for the **BUTTON ORIENTING PIN AND BUTTON ALIGNMENT.**

NOTE: Orienting pins are available to accommodate standard buttons ranging in sizes from 17 to 22 ligne. The distance between the pins must match the holes in the button. The pins enter the holes diagonally on four hole buttons. See the chart below to determine the button orienting pin required.

ORIENTING PINS FOR USE WITH STANDARD 17 TO 22 LIGNE BUTTONS

Distance Between Pins	Part Number
.108 inch (2.7 mm)	475-259
.120 inch (3.0 mm)	475-260
.134 inch (3.4 mm)	475-261
.144 inch (3.7 mm)	475-262
.156 inch (4.0 mm)	475-263

ORDERING REPAIR PARTS

ILLUSTRATIONS

This catalog has been arranged to simplify ordering repair parts. Exploded views of various sections of the mechanism are shown so that the parts may be seen in their actual position in the machine. On the page opposite the illustration will be found a listing of the parts with their part number, description and number of pieces required in the particular view being shown.

Numbers in the first column are reference numbers only, and merely indicate the position of that part in the illustration. Reference numbers should never be used in ordering parts. Always use the part number listed in the second column.

Component parts of sub-assemblies which can be furnished for repairs are indicated by indenting their descriptions under the description of the main sub-assembly. Example:

2	462-22	Thread Tension Staff, complete.	1
3	20-60	Adjusting Nut.....	1
4	21-414	Tension Spring.....	1
5	1183 L	Tension Disc.....	2
6	68-22	Tension Staff.....	1

At the back of the book will be found a numerical index of all the parts shown in this book. This will facilitate locating the illustration and description when only the part number is known.

IDENTIFYING PARTS

Where the construction permits, each part is stamped with its part number. Part numbers represent the same part, regardless of catalog in which they appear.

USE GENUINE REPAIR PARTS

Success in the operation of these machines can be secured only with genuine UNION SPECIAL Repair Parts as furnished by the Union Special Corporation, its subsidiaries and authorized distributors. They are designed according to the most approved scientific principles, and are made with utmost precision. Maximum efficiency and durability are assured.

TERMS

Prices are net cash and subject to change without notice. All shipments are forwarded f.o.b. shipping point. Parcel Post shipments are insured unless otherwise directed. A charge is made to cover postage and insurance.

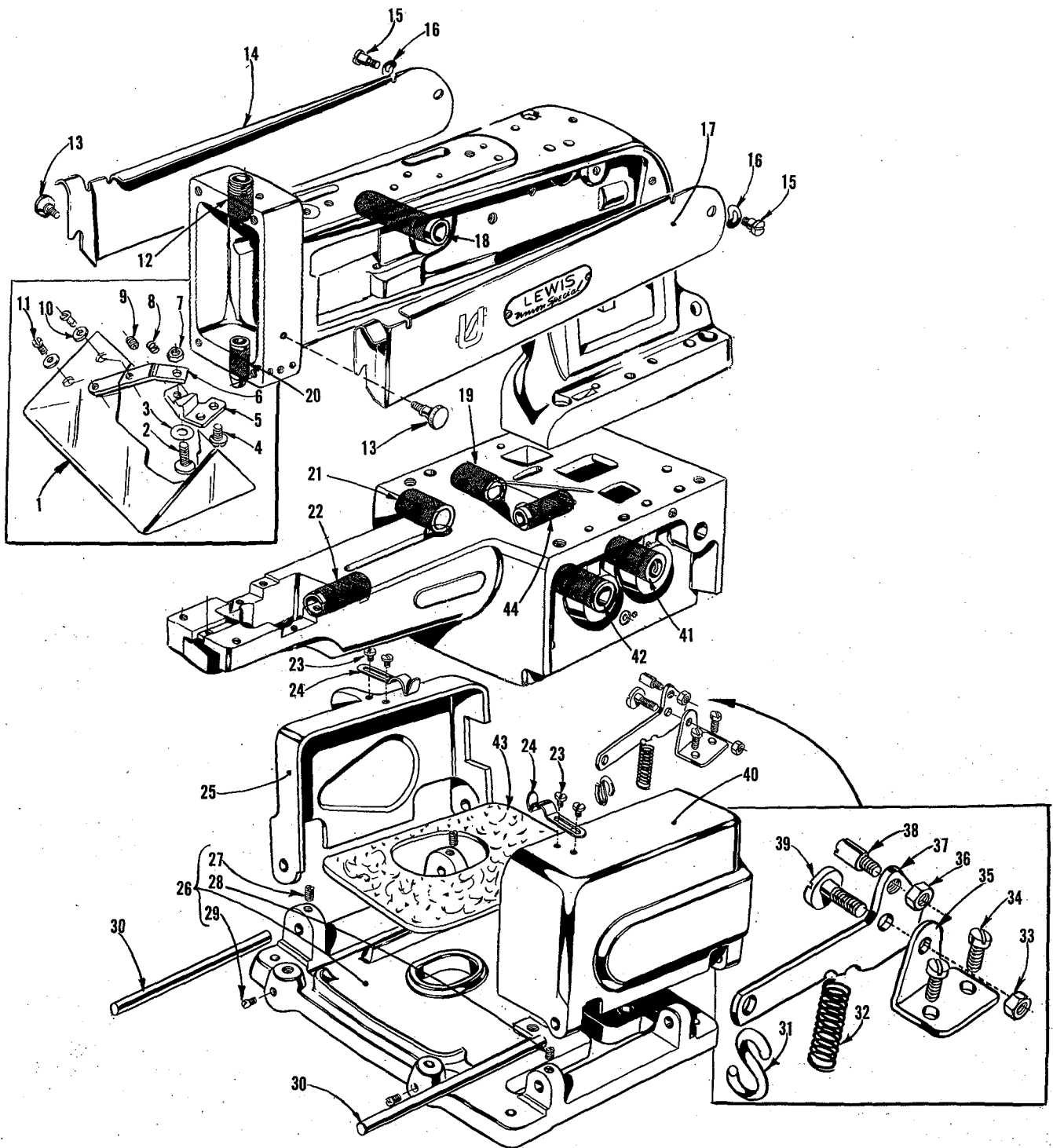

BASE, COVERS, BUSHINGS, SEWING GUARD

<u>Ref. No.</u>	<u>Part No.</u>	<u>Description</u>	<u>Amt. Req.</u>
1	8-147	Plastic, for sewing guard.....	1
2	22757	Screw.....	1
3	40-101	Washer.....	1
4	18-750	Screw.....	1
5	115-171	Mounting Block, marked "A".....	1
6	45-498	Lever.....	1
7	12934 A	Nut.....	1
8	21-449	Spring.....	1
9	22894 P	Screw.....	1
10	41358	Washer.....	2
11	22768 B	Screw.....	2
12	16-411	Needle Bar Bushing, upper.....	1
13	18-1047	Screw.....	2
14	32-311	Arm Cover, left.....	1
15	1220 L	Screw.....	2
16	12957 E	Washer.....	2
17	32-312	Arm Cover, right.....	1
18	16-412	Needle Lever Shaft Bushing.....	1
19	16-291	Camshaft Bushing, left.....	1
20	16-297	Needle Bar Bushing, lower.....	1
21	16-289	Pulley Shaft Bushing, left.....	1
22	16-292	Looper Shaft Bushing, front.....	1
23	CS337	Screw.....	4
24	21-295	Spring.....	2
25	32-192	Cover, left.....	1
26	141-4	Machine Sub-Base.....	1
27	1003 L	Set Screw.....	2
28	1005 L	Set Screw.....	1
29	18-738	Screw.....	2
30	14-399	Hinge Shaft.....	2
31	131-C163-2	"S" Hook.....	1
32	21-321	Spring.....	1
33	1009 L	Nut.....	1
34	1158 L	Screw.....	2
35	50-215	Bracket.....	1
36	1160 L	Nut.....	1
37	45-333	Stop Motion Trip Lever.....	1
38	787 L	Stop Screw.....	1
39	1235 L	Screw.....	1
40	32-191	Stop Motion and Pulley Cover, right.....	1
41	16-398	Camshaft Bushing, right.....	1
42	16-288	Pulley Shaft Bushing, right.....	1
43	144-25	Felt Pad.....	1
44	16-334	Looper Shaft Bushing, rear.....	1

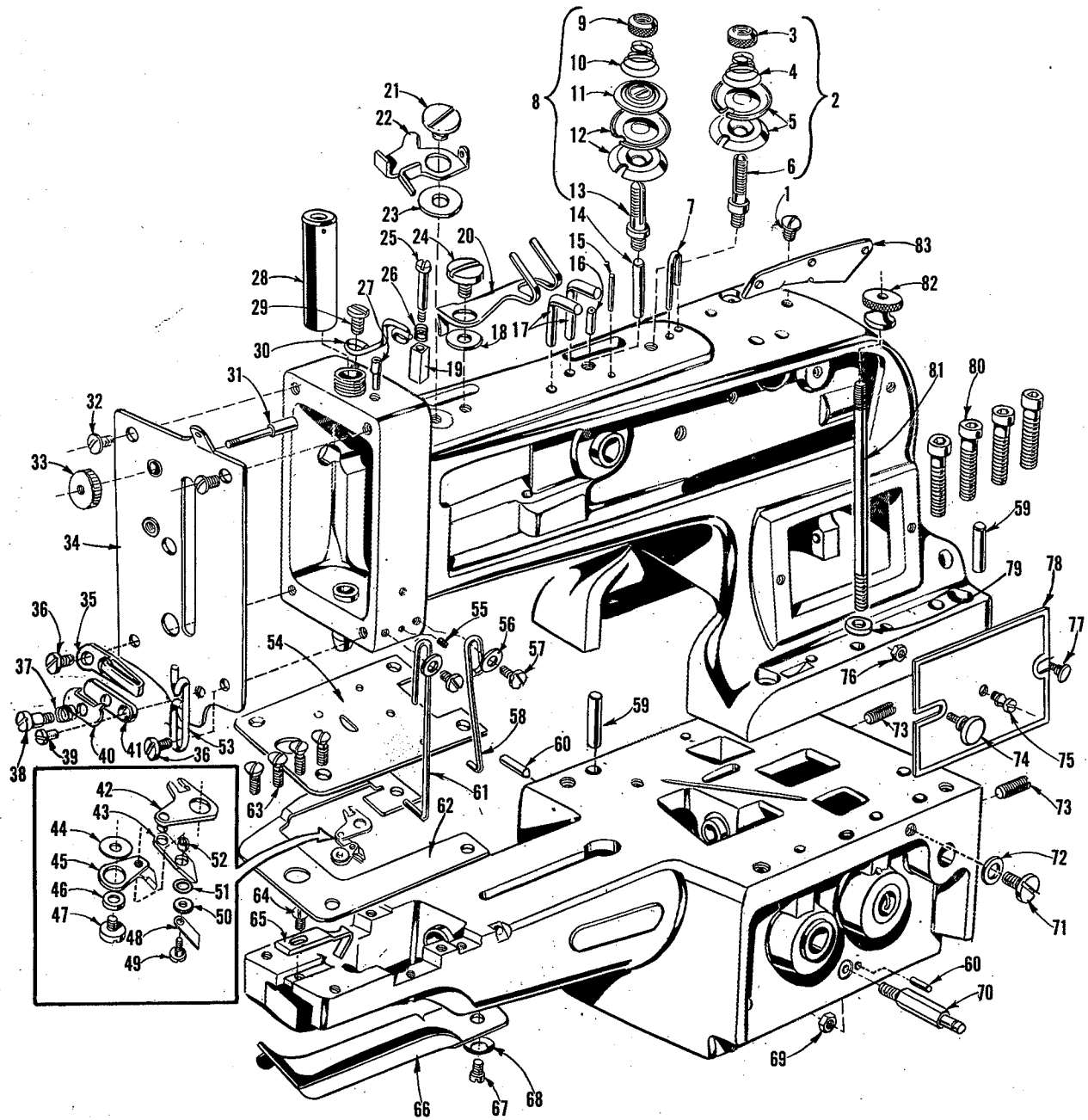

MISCELLANEOUS PLATES AND THREAD HANDLING PARTS

<u>Ref. No.</u>	<u>Part No.</u>	<u>Description</u>	<u>Amt. Req.</u>
1	18-997	Screw.....	1
2	468-22	Thread Tension Staff, complete.....	1
3	20-60	Adjusting Nut.....	1
4	21-414	Tension Spring.....	1
5	1183 L	Tension Disc.....	2
6	68-22	Tension Staff.....	1
7	41-53	Thread Guide.....	1
8	468-21	Thread Nipper Staff, complete.....	1
9	20-60	Adjusting Nut.....	1
10	21-284	Tension Spring.....	1
11	61292 H	Tension Lifting Washer.....	1
12	1183 L	Tension Disc.....	2
13	68-21	Nipper Staff.....	1
14	22-221	Tension Release Pin.....	1
15	22-195	Tension Disc Pin.....	1
16	61-89	Oil Tube.....	1
17	41-41	Thread Guide.....	2
18	40-188	Washer.....	1
19	115-107	Nipper Block.....	1
20	45-434	Thread Pull-off Lever.....	1
21	18-1088	Screw.....	1
22	4187-3	Thread Nipper, complete.....	1
23	60038 K	Washer.....	1
24	18-1088	Screw.....	1
25	18-854	Screw.....	1
26	21-310	Spring.....	1
27	61-33	Oil Tube.....	1
28	75-267	Needle Bar Guide.....	1
29	18-997	Screw.....	1
30	41-49	Thread Guide.....	1
31	26-147	Nipper Releasing Plunger.....	1
32	18-786	Screw.....	2
33	20-98	Knurled Nut.....	1
34	432-263	Machine Arm Front Cover.....	1
35	62271 C	Thread Guide.....	1
36	18-330	Screw.....	2
37	15438 C	Spring.....	1
38	18-1076	Screw.....	1
39	18-1077	Screw.....	1
40	57 WB	Needle Thread Nipper Spring Plate.....	1
41	99-345	Needle Thread Nipper Holder.....	1
42	45-493	Knife Drive Lever.....	1
43	119-89	Lower Knife.....	1

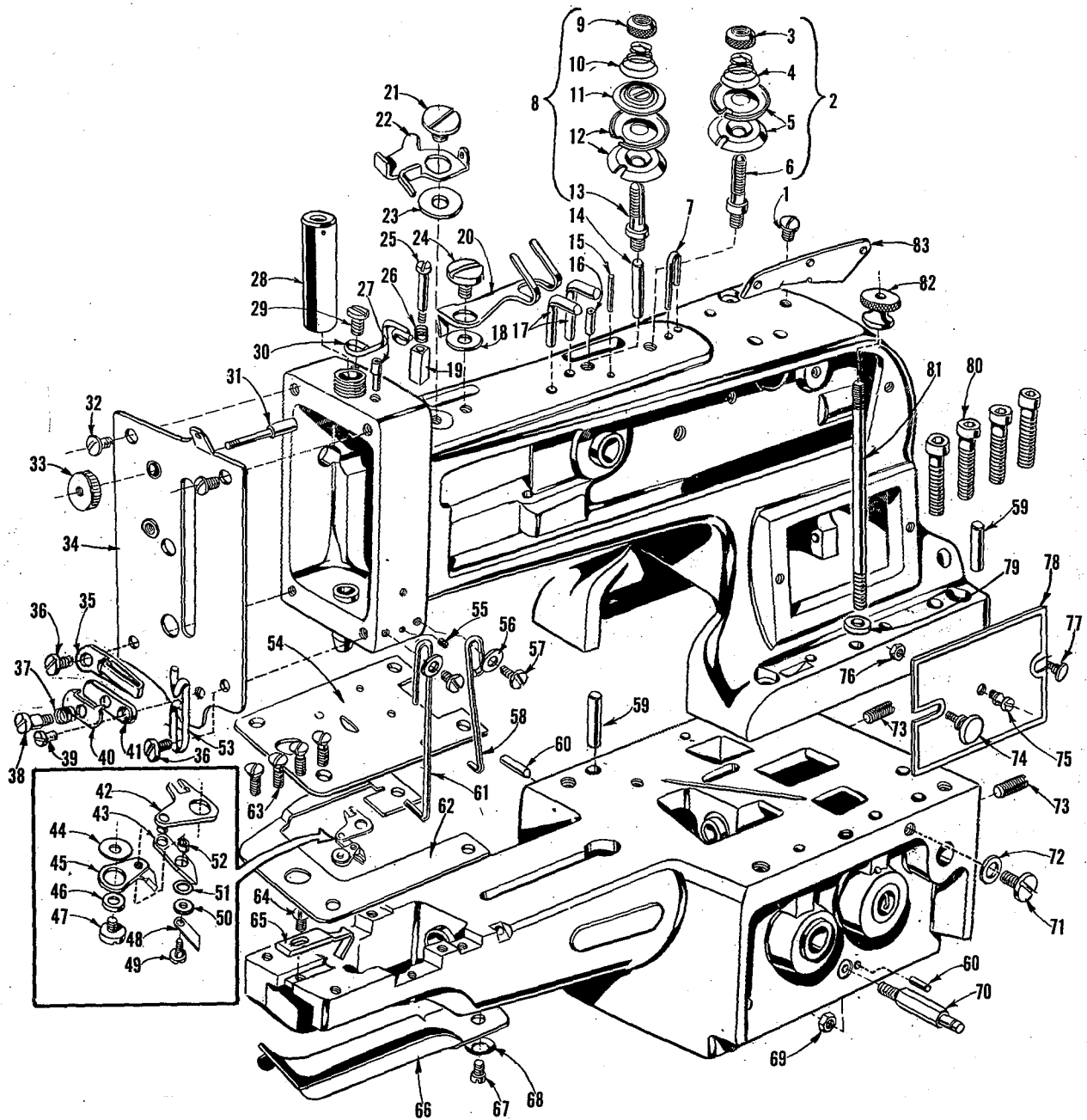

MISCELLANEOUS PLATES AND THREAD HANDLING PARTS

<u>Ref. No.</u>	<u>Part No.</u>	<u>Description</u>	<u>Amt. Req.</u>
44	157-16	Knife Spacer.....	1
45	119-88	Upper Knife.....	1
46	16-405	Upper Knife Bushing.....	1
47	18-1139	Screw.....	1
48	182-17	Separator, for Style 200-38.....	1
49	18-1140	Lower Knife Screw, for Style 200-38.....	1
-	18-1117	Lower Knife Screw, for Style 200-45.....	1
50	157-15	Spacer, for Style 200-38.....	1
51	660-648	Spring Washer.....	1
52	16-406	Lower Knife Bushing.....	1
53	51758	Thread Guide.....	1
54	110-446A	Needle Plate.....	1
55	18-533	Set Screw.....	1
56	69 H	Washer.....	2
57	18-330	Screw.....	2
58	102-10	Strike-off Wire.....	1
59	22-175	Dowel Pin.....	2
60	22-238	Timing Pin.....	2
61	71-123	Button Unloading Rod.....	1
62	110-447	Spacer Plate.....	1
63	18-920	Screw.....	4
64	18-786	Screw, for Style 200-38.....	1
-	18-750	Screw, for Style 200-45.....	1
65	8-149	Needle Guard.....	1
66	32-209	Machine Base Swing Cover.....	1
67	18-934	Screw.....	1
68	1221 L	Spring Washer.....	1
69	CS231	Nut.....	1
70	22-251	Spring Pin.....	1
71	22548	Screw.....	1
72	21657 E	Washer.....	1
73	18-547	Set Screw.....	2
74	18-286	Screw.....	1
75	18-752	Knob Screw.....	1
76	1160 L	Nut.....	1
77	SB79	Screw.....	1
78	432-198	Cover.....	1
79	40-170	Washer.....	1
80	22652 E-20	Screw.....	4
81	18-816	Screw Stud.....	1
82	1316 L	Knurled Nut.....	1
83	61470 D	Thread Guide.....	1

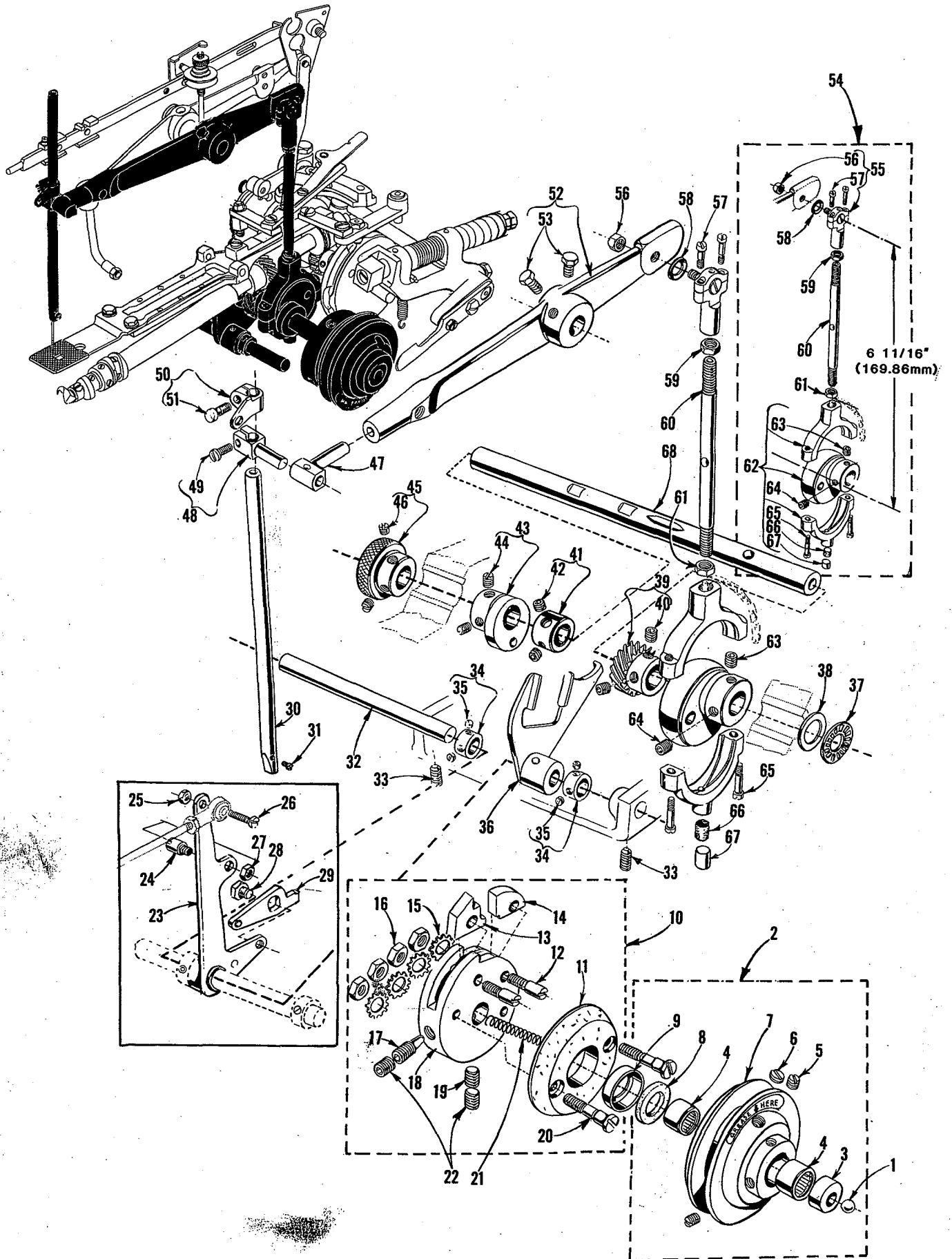

NEEDLE DRIVE, CLUTCH, STOP MOTION PARTS

Ref. No.	Part No.	Description	Amt. Req.
1	79-37	Ball.....	1
2	458-39	Pulley Assembly, complete.....	1
3	190-2 L	Pulley Insert.....	1
4	478-10	Needle Bearing.....	2
5	1005 L	Set Screw.....	2
6	18-800	Set Screw.....	1
7	58-39	Pulley.....	1
8	63-32	Grease Retaining Wick.....	1
9	40-169	Retaining Washer.....	1
10	444-334	Stop Disc, complete.....	1
11	44-288	Pulley Clutch Disc.....	1
12	18-959	Screw.....	2
13	166-7	Stop Motion Disc Pawl.....	1
14	51-20	Stop Motion Disc Latch.....	1
15	652 N-14	Eccentric Washer.....	4
16	20-127	Nut.....	4
17	18-958	Spot Screw.....	1
18	44-334	Stop Motion Disc.....	1
19	18-967	Set Screw.....	1
20	18-982	Screw.....	2
21	21-229	Spring.....	1
22	18-967	Screw.....	2
23	45-495	Drive Lever, for Style 200-38.....	1
24	22892 A	Screw, for Style 200-38.....	1
25	43443 Q	Nut, for Style 200-38.....	1
26	22747 A	Screw, for Style 200-38.....	1
27	12934 A	Nut, for Style 200-38.....	1
28	18-626	Screw, for Style 200-38.....	1
29	115-172	Stop Block, for Style 200-38.....	1
30	25-11	Needle Bar.....	1
31	18-272	Screw.....	1
32	14-362	Lever Shaft.....	1
33	1003 L	Set Screw.....	2
34	CS462	Collar.....	2
35	1022 L	Set Screw.....	2
36	445-298	Lever Engaging Button Clamp Lifting Link.....	1
37	478-27	Needle Thrust Bearing.....	1
38	40-135	Washer.....	1
39	27-169	Driving Gear, for looper shaft.....	1
40	18-996	Set Screw.....	2
41	39-92	Thrust Collar.....	1
42	1025 L	Set Screw.....	2
43	433-139	Button Clamp Lifting Link Lever Driving Eccentric, complete.....	1
44	1005 L	Set Screw.....	2
45	57-23	Handwheel.....	1
46	1025 L	Set Screw.....	2
47	117-39	Needle Bar Bearing Block.....	1
48	117-40	Needle Bar Bearing Block Clamp.....	1
49	18-71	Screw.....	1
50	41-47	Needle Bar Thread Guide.....	1
51	18-907	Screw.....	1
52	45-335 A	Needle Bar Lever.....	1
53	1333 L	Set Screw.....	2
54	447-142	Needle Bar Connecting Rod, complete.....	1
55	4124-50	Ball Joint, upper, complete.....	1
56	1009 L	Nut.....	1
57	18-391	Screw.....	2
58	40-63	Washer.....	1
59	20-80	Nut.....	1
60	71-74	Rod.....	1
61	20-81	Nut.....	1
62	4124-62	Ball Joint, lower, complete.....	1
63	18-968	Set Screw.....	1
64	18-730	Set Screw.....	1
65	18-925	Screw.....	2
66	666-19	Oil Wick.....	1
67	137-19	Oil Wick Retainer.....	1
68	14-363	Pulley Shaft.....	1

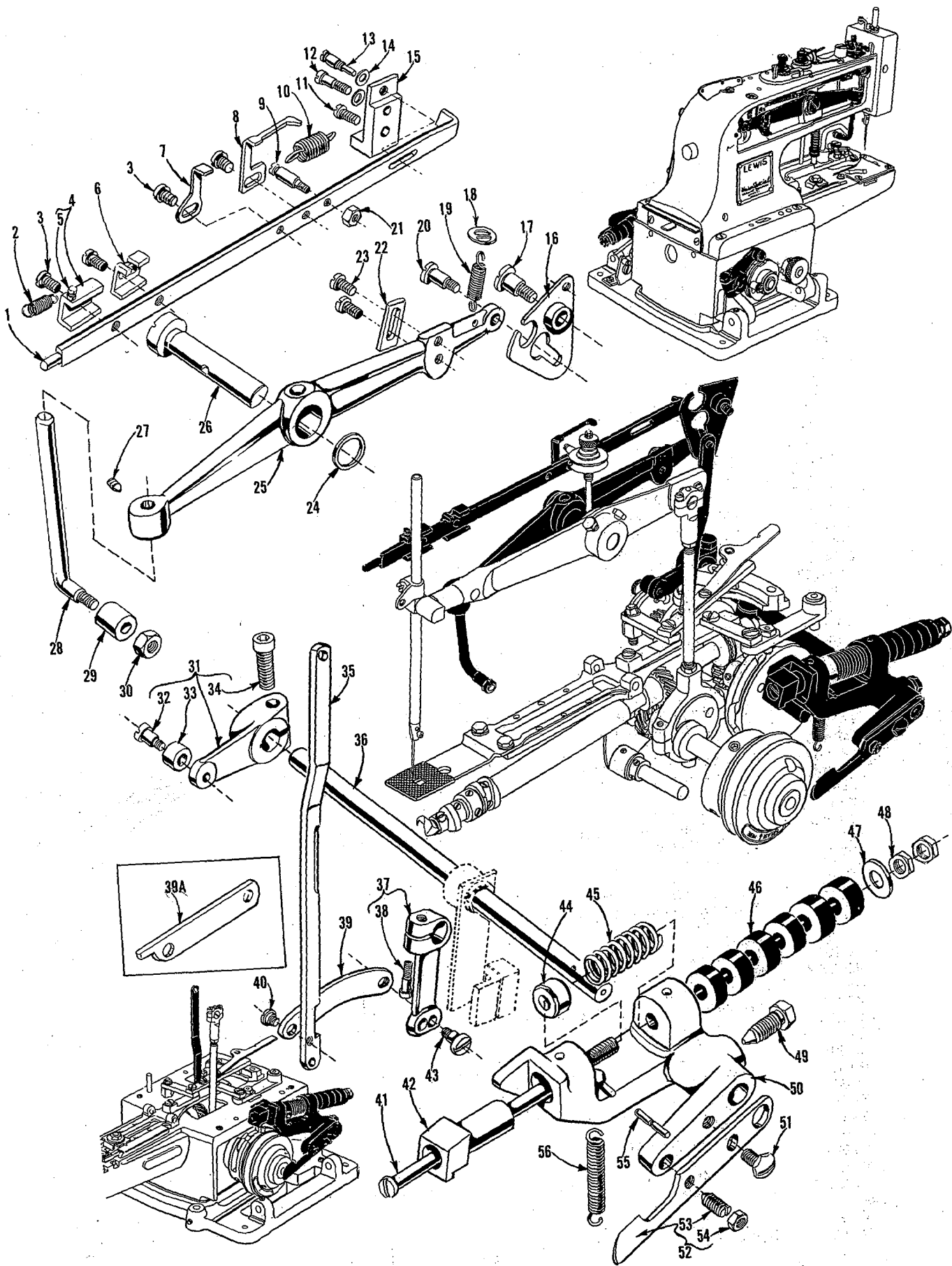

BUTTON CLAMP LIFTER, STOP MOTION, NIPPER PARTS

<u>Ref. No.</u>	<u>Part No.</u>	<u>Description</u>	<u>Amt. Req.</u>
1	138-15	Nipper Bar.....	1
2	21-366	Spring.....	1
3	18-745	Screw.....	4
4	4115-104	Nipper Bar Block, complete.....	1
5	22-235	Spring Pin.....	1
6	115-106	Nipper Bar Block.....	1
7	45-404	Tension Operating Lever.....	1
8	45-327	Thread Tension Release Lever.....	1
9	18-827	Spring Screw.....	1
10	21-379	Nipper Bar Spring.....	1
11	1158 L	Screw.....	1
12	1206 L	Screw.....	1
13	18-826	Screw.....	1
14	1185 L	Washer.....	2
15	115-175	Nipper Bar Bearing Block.....	1
16	445-405	Nipper Bar Actuating Lever.....	1
17	18-562	Screw.....	1
18	40-168	Washer.....	1
19	21-96	Spring.....	1
20	18-619	Screw.....	1
21	835 L	Nut.....	1
22	42-34	Button Clamp Lifting Lever Stop.....	1
23	18-732	Screw.....	2
24	40-143	Washer.....	1
25	45-503	Button Clamp Lifting Lever.....	1
26	14-536	Button Clamp Lifting Lever Shaft.....	1
27	22651 ED-6	Set Screw.....	1
28	71-124	Button Clamp Lifting Rod.....	1
29	35-17	Button Clamp Lifting Rod Roll.....	1
30	835 L	Nut.....	1
31	445-370	Stop Motion Tripping Lever.....	1
32	CS303-1/2	Screw.....	1
33	35-16	Stop Motion Tripping Lever Cam Roll.....	1
34	22653 E-14	Clamp Screw.....	1
35	46-162	Button Clamp Lifting Link.....	1
36	14-365	Stop Motion Lever Shaft.....	1
37	445-286	Lever, complete, engaging button clamp lifting link.....	1
38	22653 B-10	Clamp Screw.....	1
39	46-135	Link, for Style 200-45.....	1
39A	46-207	Link, for Style 200-38.....	1
40	18-809	Screw.....	1
41	71-92	Stop Motion Plunger Rod.....	1
42	26-163 A	Stop Motion Plunger.....	1
43	18-392	Screw.....	1
44	157-13	Spacer Collar.....	1
45	21-457	Spring.....	1
46	40-198	Washer.....	6
47	652-16	Washer.....	1
48	20-128	Nut.....	2
49	18-819	Screw.....	1
50	45-348	Stop Motion Plunger Lever.....	1
51	18-280	Screw.....	1
52	45-490	Lever, for applying pressure on stop motion disc.....	1
53	18-747	Spot Screw.....	1
54	20-34	Nut.....	1
55	22-266	Stop Motion Lever Restoring Spring Pin.....	1
56	21-360	Stop Motion Lever Restoring Spring.....	1

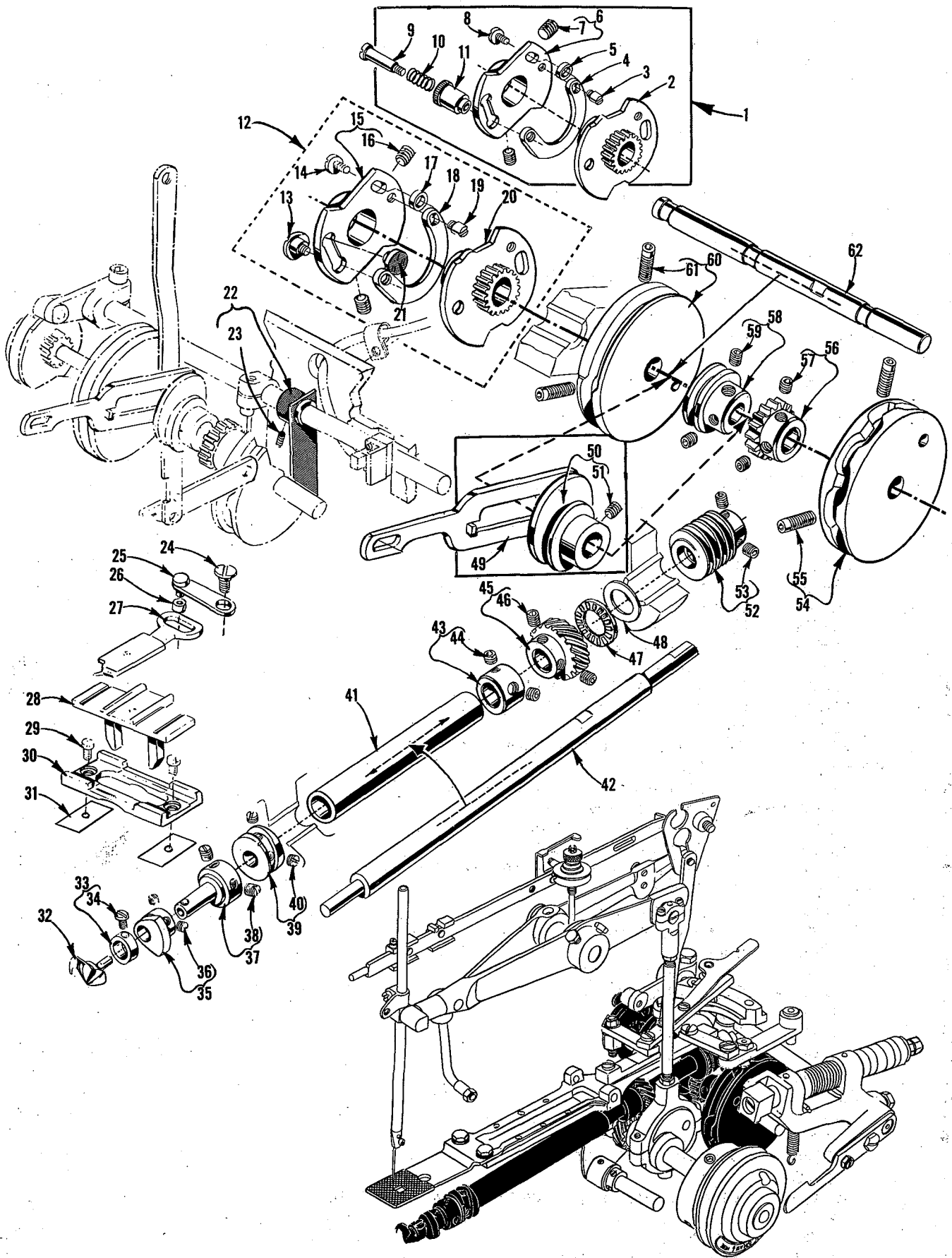

CAMS, LOOPER DRIVE, STITCH SELECTION PARTS

Ref. No.	Part No.	Description	Amt. Req.
1	434-104	Stop Motion Cam and Gear Assembly, complete with shoe and knob, for Style 200-45	1
2	434-101	Cam and Gear Assembly, right	1
3	18-39	Screw	1
4	180-4	Cam Shoe	1
5	39-151	Collar, spacing	1
6	34-104	Cam, left	1
7	18-730	Screw	2
8	22585 A	Screw	1
9	18-835	Screw	1
10	21-322	Spring	1
11	142-6	Knob	1
12	434-102	Stop Motion Cam and Gear Assembly, complete with shoe for Style 200-38	1
13	18-1112	Screw	1
14	22585 A	Screw	1
15	34-104	Cam, left	1
16	18-730	Screw	2
17	39-151	Collar, spacing	1
18	180-4	Cam Shoe	1
19	18-39	Screw	1
20	434-101	Cam and Gear Assembly, right	1
21	89-65	Filling Plug	1
22	45-507	Vane, for Style 200-38	1
23	22894 X	Screw	1
24	18-934	Screw	1
25	445-349	Loop Positioning Finger Lever	1
26	35-20	Loop Positioning Finger Lever Roll	1
27	122-58	Loop Positioning Finger	1
28	49-33	Positioning Finger Yoke Slide	1
29	18-949	Screw	2
30	190-3 L	Yoke Slide Insert	1
31	164-39	Shim, .005 inch (.127 mm) thick	As Req.
-	164-40	Shim, .010 inch (.254 mm) thick	As Req.
-	164-41	Shim, .015 inch (.381 mm) thick	As Req.
32	36-21	Looper	1
33	39-143	Collar	1
34	18-949	Screw	1
35	434-40	Loop Positioning Finger Cam, complete	1
36	18-634	Screw	2
37	70-50	Cam and Looper Sleeve	1
38	1005 L	Set Screw	2
39	34-47	Loop Positioning Finger Cam	1
40	1029 L	Set Screw	2
41	61-80	Looper Shaft Tube	1
42	14-366	Looper Shaft	1
43	39-131	Looper Shaft Collar	1
44	18-996	Set Screw	2
45	27-168	Looper Shaft Driven Gear	1
46	18-996	Set Screw	2
47	478-27	Needle Thrust Bearing	1
48	40-135	Washer	1
49	46-208	Drive Lever Link, for Style 200-38	1
50	33-168	Eccentric, complete, for Style 200-38	1
51	18-730	Set Screw	2
52	27-189	Looper Shaft Worm Gear	1
53	18-730	Set Screw	2
54	34-53	Cam, right side	1
55	18-984	Set Screw	2
56	27-155	Camshaft Driven Gear	1
57	18-996	Set Screw	2
58	39-107	Collar	1
59	18-730	Set Screw	2
60	34-35	Cam, left side	1
61	18-984	Set Screw	2
62	14-364	Camshaft	1

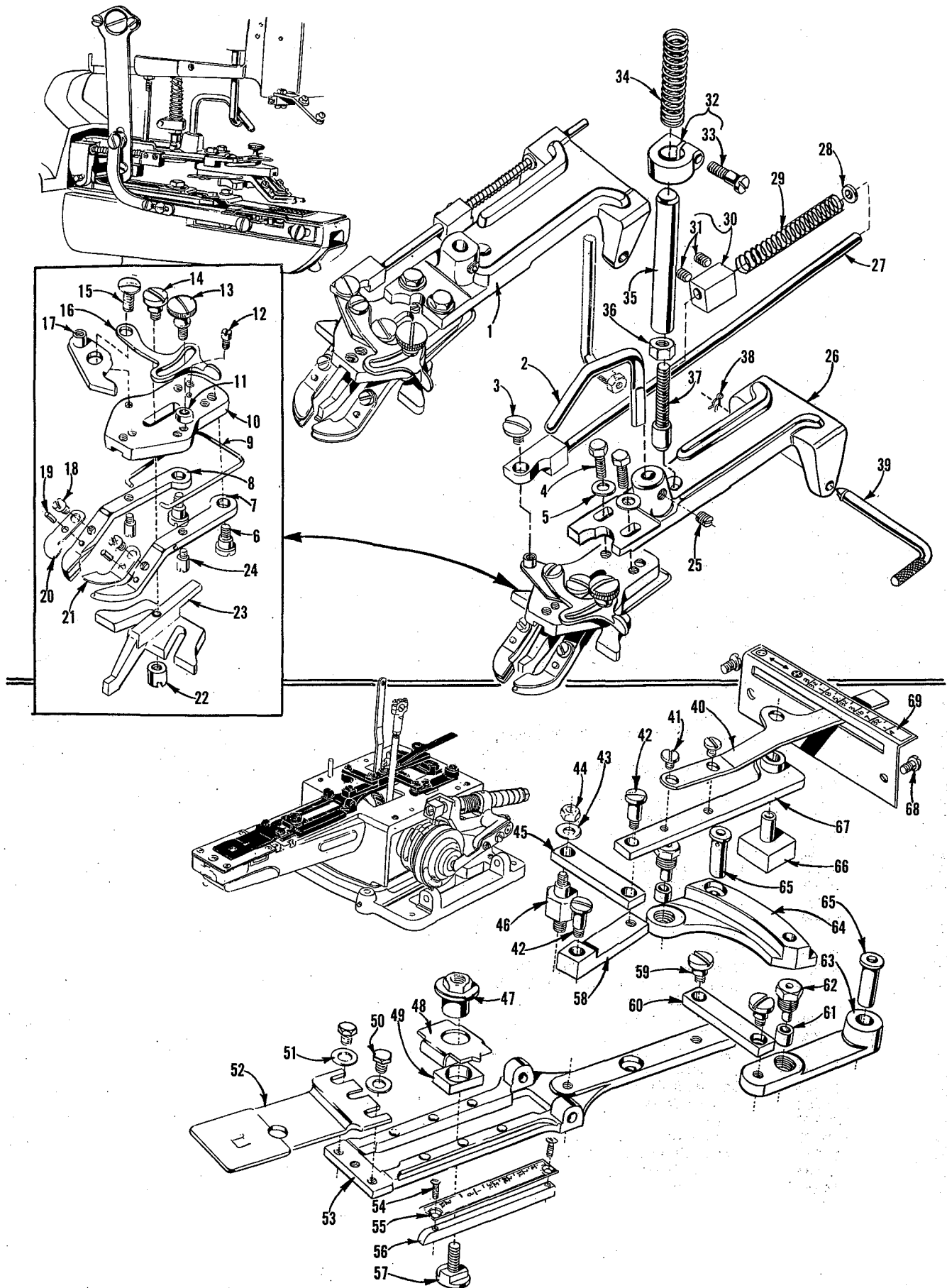

BUTTON CLAMP, POSITIONING PARTS AND FEED PLATE

Ref. No.	Part No.	Description	Amt. Req.
1	430-63-7	Button Clamp Assembly, for Style 200-45	1
2	71-112	Button Clamp Lifting Rod	1
3	22542	Screw	1
4	18-873	Screw	2
5	40-38	Washer	2
6	18-929	Hinge Screw	2
7	45-346	Button Clamp Lever Jaw, right	1
8	45-347	Button Clamp Lever Jaw, left	1
9	21-315	Spring	1
10	99-316	Button Clamp Lever Jaw Holder	1
11	157-10	Spacer, .100 inch (2.54 mm) thick	1
12	18-272	Screw	1
13	18-945	Clamp Screw	1
14	18-931	Screw	1
15	1731 L	Hinge Screw	1
16	45-332	Stop Lever	1
17	166-14	Button Clamp Pawl	1
18	1189 L	Screw	2
19	22-205	Locating Pin	2
*20	21-337	Button Holding Spring, left, for buttons up to 1/8 inch (3.17 mm) thick	1
*21	21-336	Button Holding Spring, right, for buttons up to 1/8 inch (3.17 mm) thick	1
22	20-123	Locknut	1
23	158-11	Slide	1
24	18-930	Bearing Screw	2
25	18-1087	Set Screw	1
26	99-353	Button Clamp Holder	1
27	71-119	Push Rod	1
28	80265	Thrust Washer	1
29	21-440	Spring	1
30	115-169	Push Rod Tripping Block	1
31	22894 W	Screw	2
32	439-153	Collar	1
33	18-375	Screw	1
34	21-317	Spring	1
35	22-347	Stop Pin	1
36	12538	Nut	1
37	18-1128	Screw	1
38	21-407	Spring Clip	1
39	22-224	Hinge Pin	1
40	21-287	Handle and Indicator Spring	1
41	CS337	Screw	2
42	18-619	Screw	2
43	40-38	Washer	1
44	1160 L	Nut	1
45	46-137	Link	1
46	17-124	Stud	1
47	20-109	Nut	1
48	155-14	Indicator	1
49	69-17	Bearing Block	1
50	18-626	Screw	2
51	40-38	Washer	2
52	24-338	Feed Plate	1
53	158-29	Slide Plate	1
54	18-966	Screw	2
55	110-205	Graduated Plate	1
56	115-108	Block	1
57	18-818	Screw	1
58	46-138	Link	1
59	18-392	Screw	2
60	46-137	Link	1
61	35-15	Cam Roll	2
62	18-814	Screw	2
63	45-290	Lever	1
64	45-288	Lever	1
65	22-219	Pin	2
66	69-16	Slide Block	1
67	446-136	Link	1
68	18-330	Screw	2
69	110-206	Graduated Plate	1

*NOTE: For sewing thick buttons requiring up to an additional 11/64 inch (4.36 mm) in height, order No. 21-393 Button Holding Spring, left and No. 21-392 Button Holding Spring, right; as an extra send and charge item.

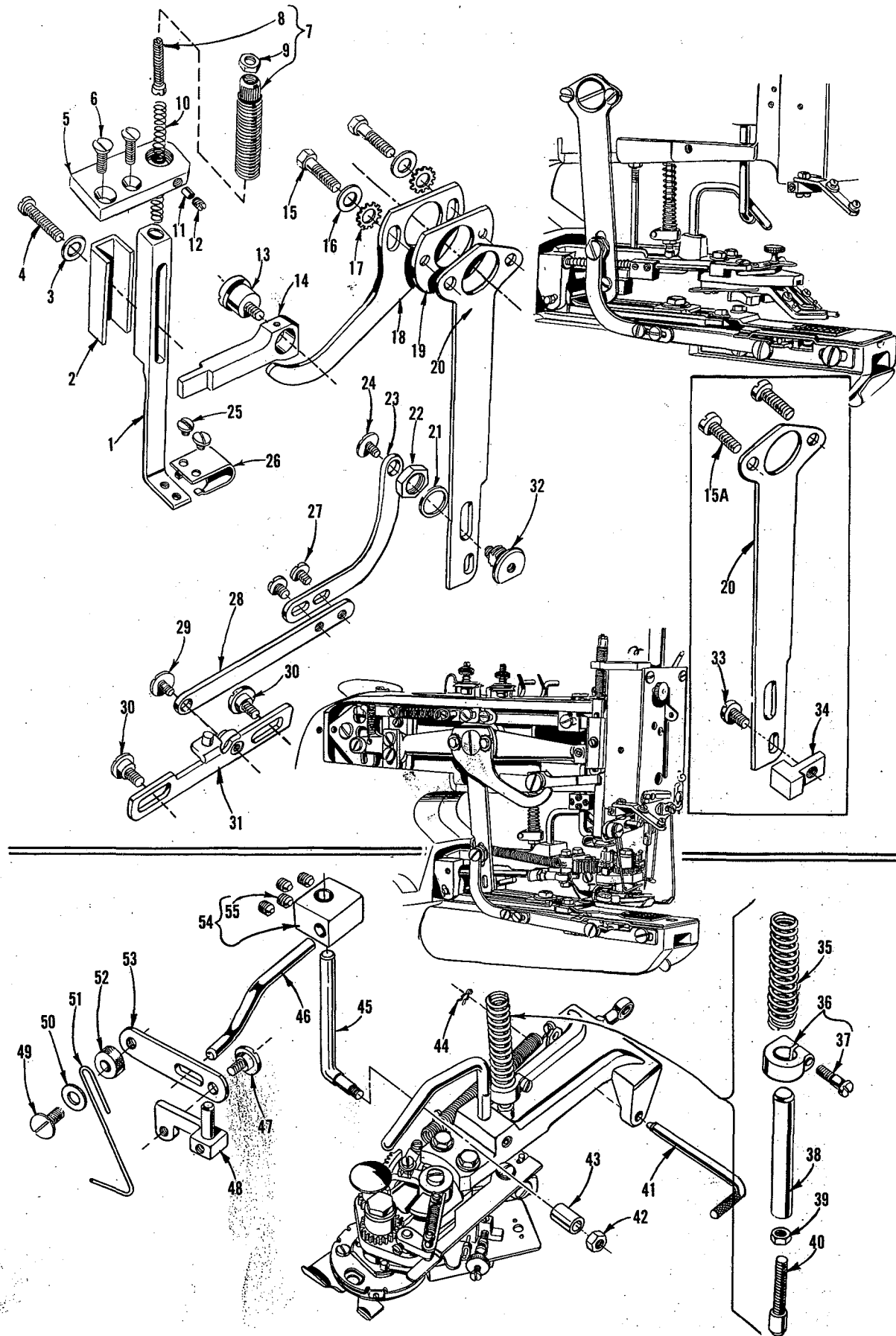

ORIENTING PIN LIFTER, KNIFE DRIVE AND THREAD WIPER PARTS

<u>Ref. No.</u>	<u>Part No.</u>	<u>Description</u>	<u>Amt. Req.</u>
1	50-315	Lifter Bracket, for Style 200-38.	1
2	75-268	Lifter Guide, for Style 200-38.	1
3	69 H	Washer, for Style 200-38.	1
4	22660 A-48	Screw, for Style 200-38.	1
5	115-176	Block, for spring screw, for Style 200-38.	1
6	22637 N-32	Screw, for Style 200-38.	2
7	18-1136	Stop Screw, for Style 200-38.	1
8	18-1135	Spring Screw.	1
9	907	Nut.	1
10	21-440	Spring, for Style 200-38.	1
11	89-64	Plug, for Style 200-38.	1
12	22743	Set Screw, for Style 200-38.	1
13	18-1131	Screw, for Style 200-38.	1
14	45-505	Lift, for Style 200-38.	1
15	T-38	Screw, for Style 200-38.	2
15A	22596	Screw, for Style 200-45.	2
16	40-38	Washer, for Style 200-38.	2
17	652 N-14	Lockwasher, for Style 200-38.	2
18	45-504	Lifter Lever, for Style 200-38.	1
19	157-11	Spacer Washer, for Style 200-38.	1
20	45-481	Knife Driving Lever.	1
21	815 L	Washer.	1
22	51170 D	Nut.	1
23	46-203	Knife Driving Lever Arm.	1
24	22542	Screw.	1
25	18-1133	Screw, for Style 200-38.	2
26	21-458	Lifter Spring, for Style 200-38.	1
27	CS337	Screw.	2
28	46-204	Knife Driving Link.	1
29	22542	Screw.	1
30	18-1089	Screw.	2
31	45-494	Thread Cutting Knife Lever.	1
32	17-178	Knife Drive Lever Adjusting Stud.	1
33	94	Screw, for Style 200-45.	1
34	115-168	Tripping Block, for Style 200-45.	1
35	21-317	Spring.	1
36	439-153	Collar.	1
37	18-375	Screw.	1
38	22-347	Stop Pin.	1
39	12538	Nut.	1
40	18-1128	Screw.	1
41	22-224	Hinge Pin.	1
42	835 L	Nut.	1
43	35-17	Button Clamp Lifting Rod Roll.	1
44	21-407	Spring Clip.	1
45	71-124	Button Clamp Lifting Rod.	1
46	45-484	Thread Wiper Drive Lever, for Style 200-38.	1
47	1776 L	Screw, for Style 200-38.	1
48	50-298	Thread Wiper Mounting Bracket, for Style 200-38.	1
49	22581	Screw, for Style 200-38.	1
50	35794 A	Washer, for Style 200-38.	1
51	45-502	Thread Wiper, for Style 200-38.	1
52	40-204	Washer, for Style 200-38.	1
53	45-499	Wiper Arm, for Style 200-38.	1
54	50-299	Thread Wiper Drive Lever Bracket, for Style 200-38.	1
55	22894 P	Set Screw.	4

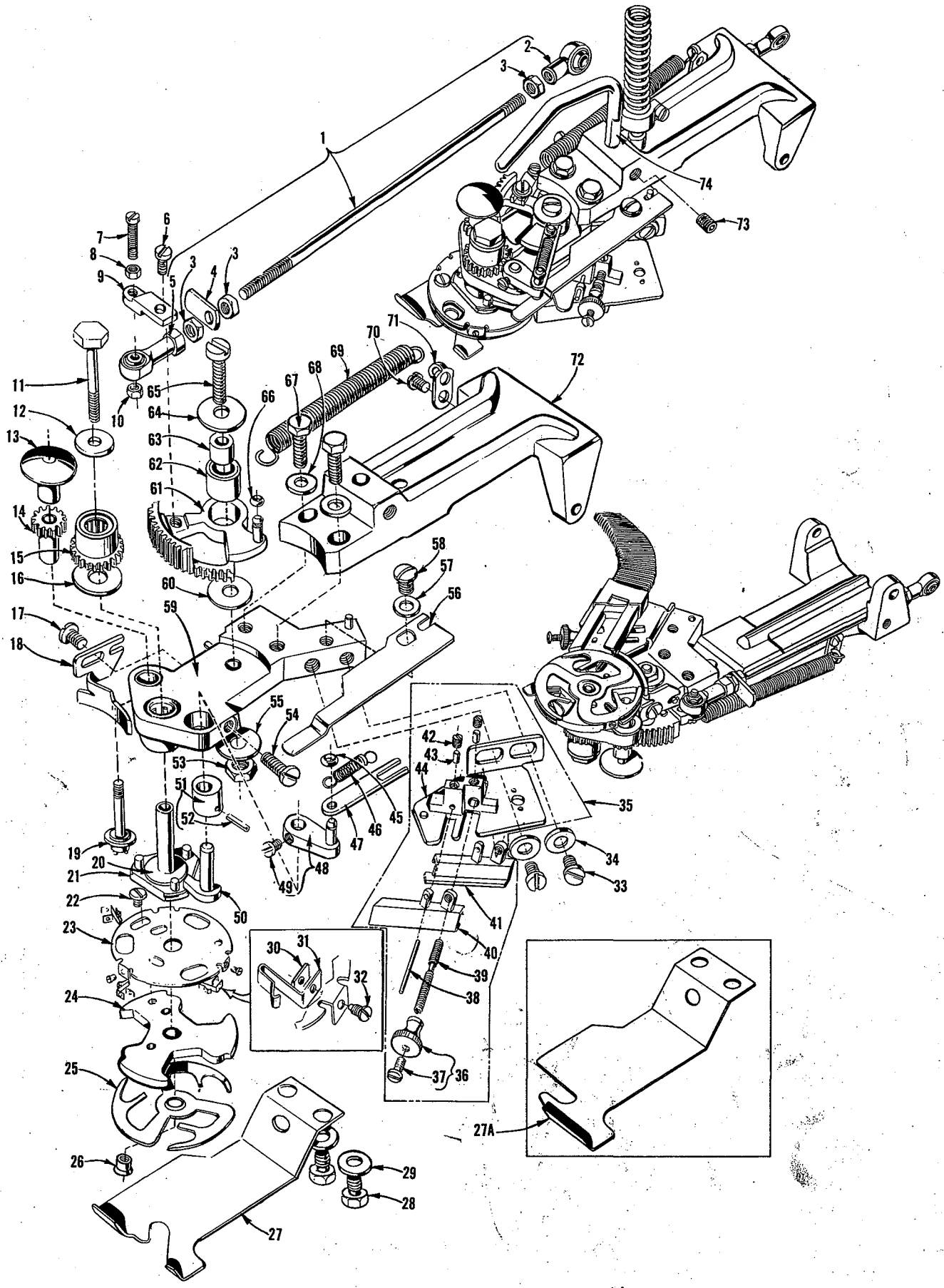

BUTTON FEEDER CLAMP ASSEMBLY No. 430-95 FOR STYLE 200-38

<u>Ref. No.</u>	<u>Part No.</u>	<u>Description</u>	<u>Amt. Req.</u>
*1	447-143	Connecting Rod Assembly, for button feeder clamp assembly	1
*2	643-296 Blk	Ball Joint	1
*3	RM2791-2	Nut	3
*4	76-20	Handle	1
*5	4124-63	Ball Joint	1
6	22768	Screw	1
7	22747 A	Screw	1
8	43443 Q	Nut	1
9	137-158	Spring Retainer	1
10	43443 Q	Nut	1
11	18-1124	Screw	1
12	40-206	Washer	1
13	22-351	Orienting Lifting Pin	1
14	16-408	Orienting Pin Bushing	1
15	111-3	Gear Clutch	1
16	40-C-193	Washer	1
17	18-750	Screw	1
-18	34-103	Button Guiding Cam	1
19	475-259	Orienting Pin Assembly, .108 inch (2.74 mm) center distance between pins	1
-	475-260	Orienting Pin Assembly, .120 inch (3.05 mm) center distance between pins	1
-	475-261	Orienting Pin Assembly, .134 inch (3.40 mm) center distance between pins	1
-	475-262	Orienting Pin Assembly, .144 inch (3.66 mm) center distance between pins	1
-	475-263	Orienting Pin Assembly, .156 inch (3.96 mm) center distance between pins	1
20	40-C-193	Washer	1
21	74-5	Button Holder Chuck	1
22	18-1133	Screw	1
23	110-448	Button Cover Plate	1
24	99-360	Button Holder, used for .100 in. min. to .125 in. max. (2.54 mm min. to 3.18 mm max.) button thickness	1
*	99-363	Button Holder, used for .080 in. min. to .105 in. max. (2.03 mm min. to 2.67 mm max.) button thickness	1
25	21-453	Button Holder Spring	1
26	20-154	Button Plate Nut	1
27	21-451	Button Unloading Spring, right	1
-*27A	21-452	Button Unloading Spring, left	1
28	18-626	Screw	2
29	40-38	Washer	2
30	20-151	Spring Clamp Nut	3
31	21-450	Button Positioning Spring	3
32	18-1148	Screw	3
33	18-750	Screw	2
34	40-38	Washer	2

*Are not components of assembly No. 430-95.

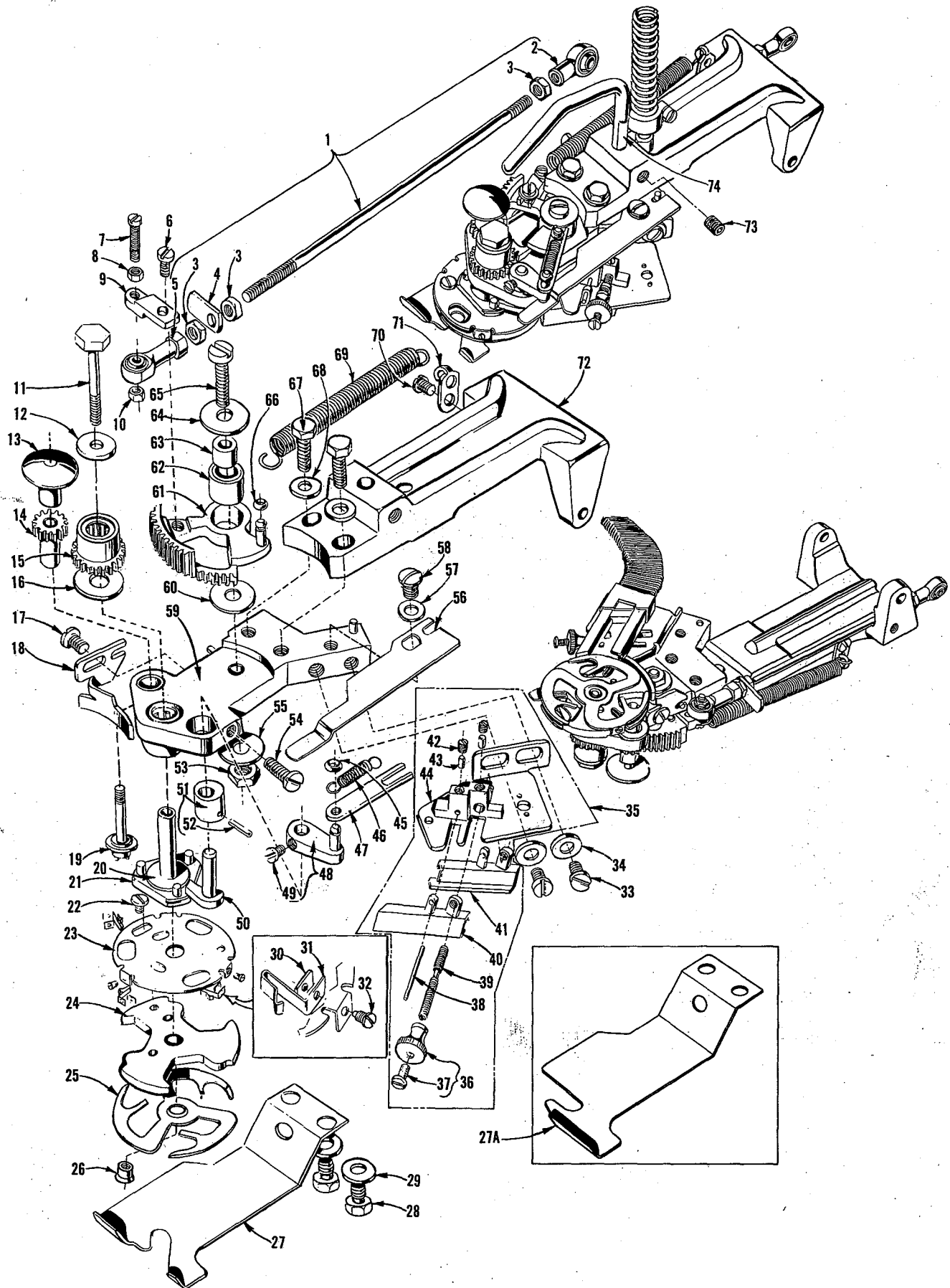

BUTTON FEEDER CLAMP ASSEMBLY No. 430-95 FOR STYLE 200-38

<u>Ref. No.</u>	<u>Part No.</u>	<u>Description</u>	<u>Amt. Req.</u>
35	475-264	Lower Guide Track Assembly, used for .100 in. min. to .125 in. max. (2.54 mm min. to 3.18 mm max.) button thickness.....	1
*	475-274	Lower Guide Track Assembly, used for .080 in. min. to .105 in. max. (2.03 mm min. to 2.67 mm max.) button thickness.....	1
36	20-155	Nut, complete.....	1
37	22768 L	Screw.....	1
38	22-342	Pin.....	1
39	18-1120	Screw.....	1
40	75-265	Guide Track, right, for assembly No. 475-264.....	1
-	75-275	Guide Track, right, for assembly No. 475-274.....	1
41	75-264	Guide Track, left, for assembly No. 475-264.....	1
-	75-274	Guide Track, left, for assembly No. 475-274.....	1
42	28 B	Screw.....	2
43	89-64	Plug.....	2
44	50-313	Guide Track Bracket, for assembly No. 475-264.....	1
-	50-318	Guide Track Bracket, for assembly No. 475-274.....	1
45	660-653	"O" Ring.....	1
46	21-456	Spring.....	1
47	46-209	Stop Link.....	1
48	45-497	Control Lever.....	1
49	22564	Screw.....	1
50	45-496	Escapement Lever.....	1
51	70-79	Eccentric Sleeve.....	1
52	660-219 W	Pin.....	1
53	9937	Nut.....	1
54	22541 A	Screw.....	1
55	40-202	Washer.....	1
56	21-454	Release Spring.....	1
57	53634 C	Washer.....	1
58	18-750	Screw.....	1
59	50-314	Gear Bracket.....	1
60	40-202	Washer.....	1
61	28-7	Drive Gear.....	1
62	16-407	Bushing.....	1
63	16-413	Ferrule.....	1
64	40-206	Washer.....	1
65	22874	Screw.....	1
66	660-653	"O" Ring.....	1
67	18-1137	Screw.....	2
68	40-38	Washer.....	2
69	63495 B	Spring.....	1
70	RM2805-5	Screw.....	1
71	63470 A	Spring Positioner.....	1
72	99-359	Button Feeder Holder.....	1
73	18-1126	Set Screw.....	1
74	71-112	Lifter Rod.....	1

*Are not components of assembly No. 430-95.

99-361

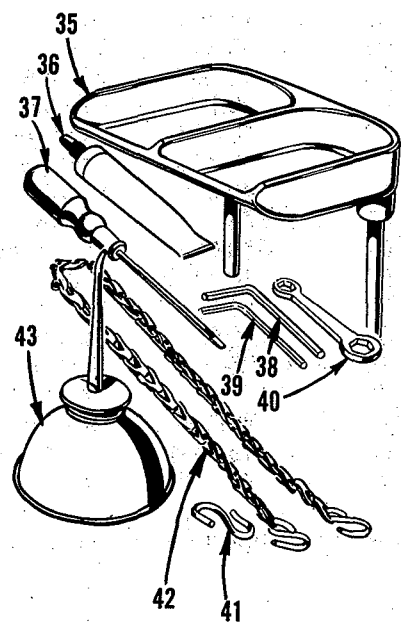
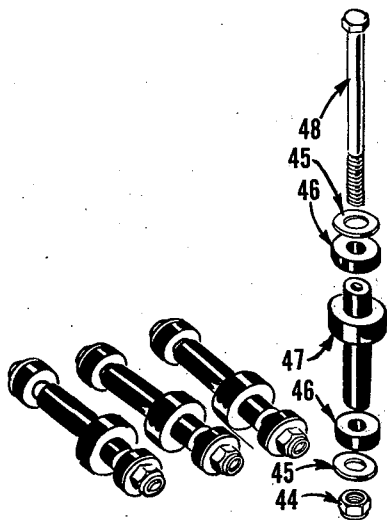
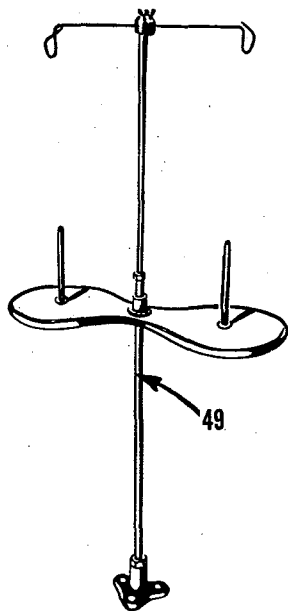
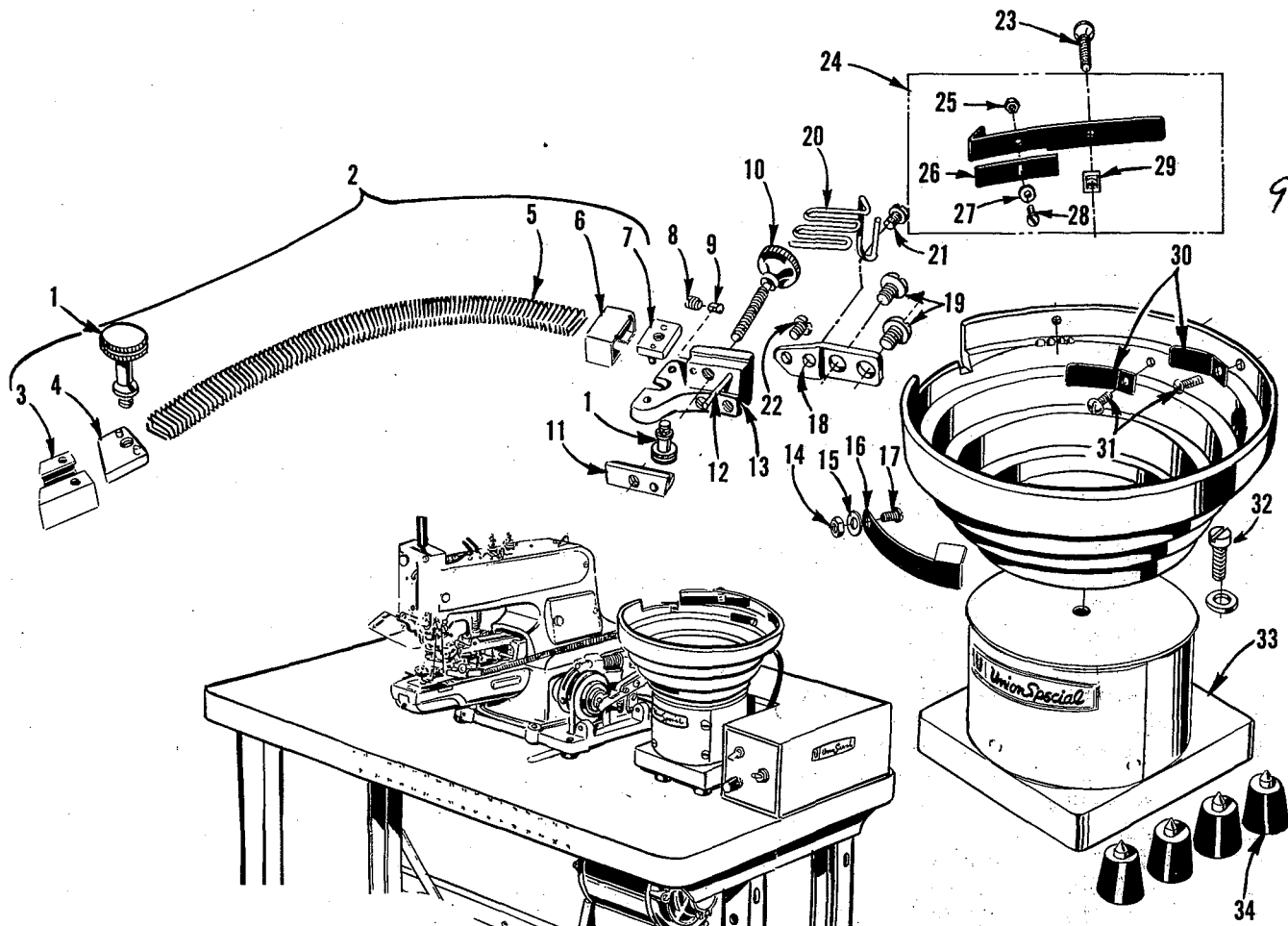

**BUTTON BOWL, VIBRATOR FEEDER,
AND STANDARD ACCESSORIES
(FOR STYLE 200-38 ONLY, UNLESS OTHERWISE SPECIFIED)**

Ref. No.	Part No.	Description	Amt. Req.
1	18-1147	Thumbscrew	2
2	461-87	Button Guide Tube Assembly, used for .100 in. min. to .125 in. max. (2.54 mm min. to 3.18 mm max.) button thickness	1
-	461-95	Button Guide Tube Assembly, used for .080 in. min. to .105 in. max. (2.03 mm min. to 2.67 mm max.) button thickness	1
3	137-160	Spring Retainer	1
4	115-174	Lower Mounting Block, for assembly No. 461-87	1
-	115-184	Lower Mounting Block, for assembly No. 461-95	1
5	21-455	Button Feeding Chute, for assembly No. 461-87	1
-	21-455-1	Button Feeding Chute, for assembly No. 461-95	1
6	137-159	Spring Retainer	1
7	115-173	Mounting Block, for assembly No. 461-87	1
-	115-185	Mounting Block, for assembly No. 461-95	1
8	22743	Screw	1
9	89-64	Nylon Plug	1
10	18-1142	Screw	1
11	75-266	Mounting Bracket Track	1
12	22-342	Pin	1
13	50-311	Spring Mounting Bracket, upper	1
*14	NU-13	Nut	1
*15	69H	Washer	1
*16	77-1	Door	1
*17	SC181	Screw	1
18	50-312	Mounting Bracket	1
19	18-1121	Screw	2
20	75-270	Cover	1
21	RM2805-5	Screw	1
22	22635 C-12	Screw	1
*23	18-1127	Screw	1
*24	122-60	Button Holder Track Adjusting Finger	1
25	60078 Z	Nut	1
26	162-22	Finger Blade	1
27	652 E-6	Washer	1
28	73 A	Screw	1
29	20-153	Spring Nut	1
*30	122-53	Wiper Strip	2
*31	18-1121	Screw	2
32	22810	Screw	1
33	197-1	Button Bowl Vibrator Feeder	1
34	51295 B	Isolator	4
35	4186-1	Button Tray, for Style 200-45	1
36	28604 P	Grease Tube, for all Styles	1
37	21201	Screwdriver, round steel, diameter 9/64 inch (3.57 mm), length over-all 7 11/16 inches (195.26 mm), for all Styles	1
38	WR57	Wrench, 5/32 inch (3.97 mm) hexagonal, for all Styles	1
39	WR56	Wrench, 1/8 inch (3.18 mm) hexagonal, for all Styles	1
40	59-6	Double End Box Wrench, 5/16 and 7/16 inch (7.94 and 11.11 mm) hexagonal, for all Styles	1
41	131-C163-1	"S" Hook, for all Styles	1
42	421 D-34	Chain, for all Styles	1
43	413	Oil Can, for all Styles	1
44	660-415	Nut, for all Styles	4
45	40-181	Washer, for all Styles	8
46	40-198	Isolator Washer, for all Styles	8
47	144-33	Isolator, for all Styles	4
48	22640 H-224	Capscrew, for all Styles	4
49	29480 DP	Thread Stand, for all Styles	1

*Components of Button Holder Bowl Assembly No. 99-361.

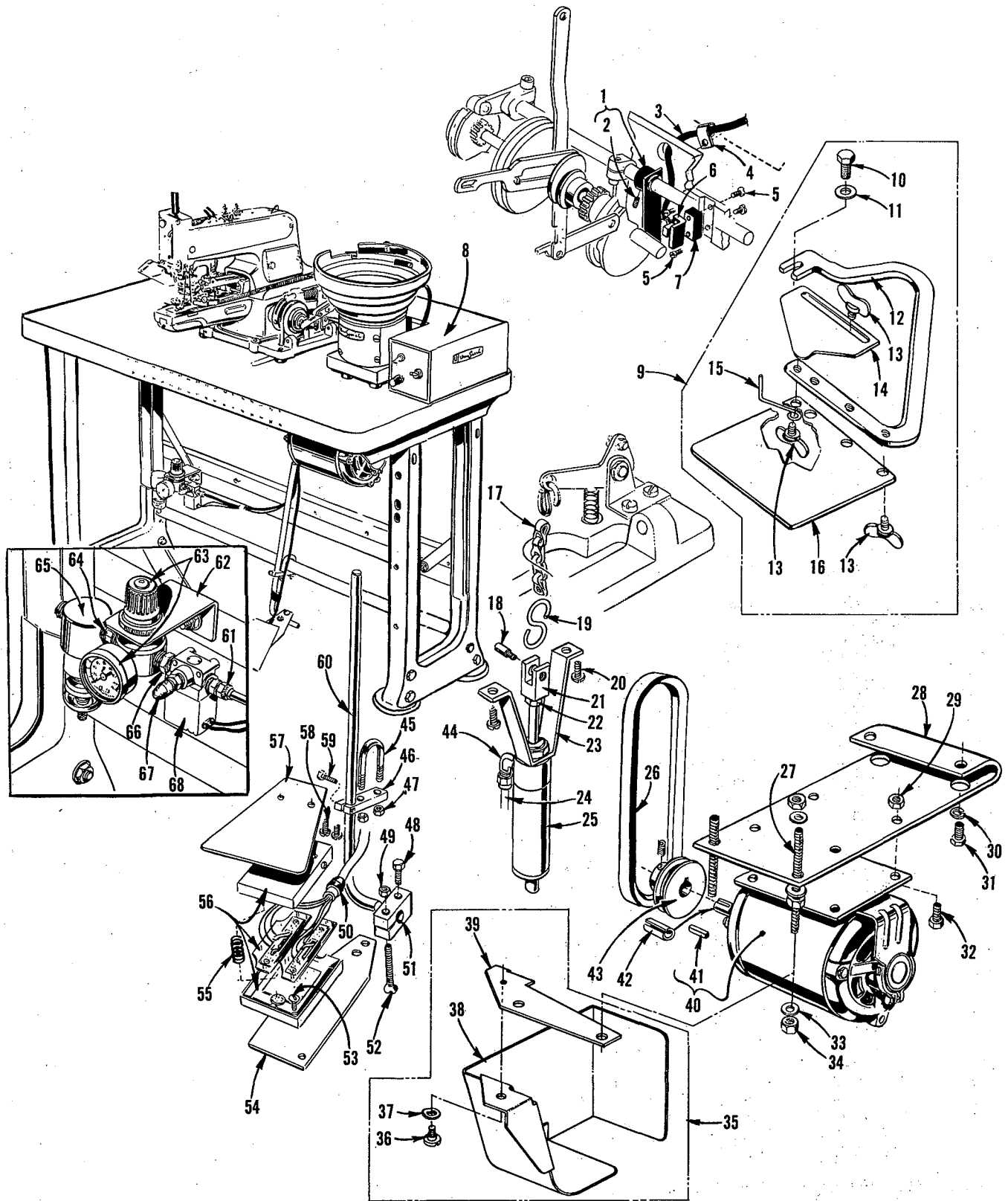

**OPTIONAL ACCESSORIES, MOTORS AND BUTTON GAUGE
(FOR STYLE 200-38 ONLY, UNLESS OTHERWISE SPECIFIED)**

<u>Ref. No.</u>	<u>Part No.</u>	<u>Description</u>	<u>Amt. Req.</u>
1	45-507	Vane	1
2	22894 X	Screw	1
3	670 E-159	Vane Switch Cable	1
4	660-352	Cable Clamp	1
5	18-989	Screw	4
6	670 B-50	Vane Switch	1
7	115-177	Switch Mounting Block	1
8	29480 RT	Power Box Assembly, for conversion of 220/380/440 V power supply to 110 V as required for vibrator feeder	1
	29480 RV	Kit of Parts, for conversion of 29480 RT to automatic cycling device which will automatically cycle the machine at pre-determined intervals; includes parts Ref. Nos. 3 thru 7, 14 thru 24, and 42 thru 65.	1
	29480 RW	Automatic Cycling Device Kit of Parts, (complete)	1
9	407-15	Button Spacer Gauge Assembly, for all Styles	1
10	18-629	Screw, for mounting	1
11	40-38	Washer	1
12	50-310	Bracket	1
13	22756 B	Thumbscrew	3
14	7-15	Spacer Gauge	1
15	122-56	Depth Gauge	1
16	110-449	Backing Plate	1
17	130-12	Start Chain	1
18	22892 A	Screw	1
19	131-C163-1	"S" Hook	1
20	SC333 A	Screw	2
21	56383 K	Cylinder Clevis	1
22	21233 FB	Locknut	1
23	50-316	Air Cylinder Mounting	1
24	RM2997 D	Poly-Flow Tubing	1
25	660-397	Air Cylinder	1
26	21261M-440	"V" Belt, 44 inch (1117.6 mm) outside circumference	1
27	21697 AF-32	Motor Hanger Adjusting Stud, for all Styles	2
28	21697 AE	Motor Hanger, for all Styles	1
29	651-20	Nut, for all Styles	4
30	652A-20	Lock Washer, for all Styles	4
31	22642 K-32	Screw, for all Styles	2
32	22642 K-48	Screw, for all Styles	4
33	652-20	Washer, for all Styles	8
34	651-20	Nut, for all Styles	6
35	408-150	Belt Guard Assembly, for all Styles	1
36	1220 L	Shoulder Screw	1
37	12957 E	Spring Washer	1
38	8-150	Belt Guard	1
39	50-319	Belt Guard Bracket	1
40	28741 H	Electric Motor, 1 phase, 60 Hz., 110 volts, for all Styles	1
	28742 AG	Electric Motor, 3 phase, 50/60 Hz., 208/220/380/440 volts, for all Styles	1
41	108-9	Key	1
42	660-615	Split Steel Bushing	1
43	28602 AS-18	Electro Drive Pulley, 2 1/4 inches (57.15 mm) working diameter	1
	28602 AS-22	Electro Drive Pulley, 2 3/4 inches (69.85 mm) working diameter	1
44	660-401	Elbow Connector	1
45	21104 N-6	"U" Bolt	1
46	30-96	Treadle Rod Clamp	1
47	651 B-24	Nut	2
48	22640 H-64	Screw	1
49	NU-16	Nut	1
50	RM3789-6	Connector	1
51	AS-4-416	Pedal Clamp	1
52	22637 C	Screw	1
53	RM2813-3	Screw	2
54	670 B-10	Switch Plate	1
55	21-459	Spring	1
56	670 B-12	Switch Assembly	1
57	RM3525	Switch Treadle Plate	1
58	RM2813-7	Screw	2
59	RM3306-2	Screw	1
60	AS-4-414	Treadle Rod	1
61	660-400	Male Connector	1
62	39583 A	Mounting Bracket	1
63	671 D-7	Pressure Regulator and Gauge	1
64	671 F-7	Nipple	1
65	671 D-5	Air Line Filter	1
66	RM3320-1	Reducing Nipple	1
67	660-403	Muffler	1
68	671-44	Solenoid Valve	1

NUMERICAL INDEX OF PARTS

<u>Part No.</u>	<u>Page No.</u>	<u>Part No.</u>	<u>Page No.</u>	<u>Part No.</u>	<u>Page No.</u>
AS4-414	55	18-826	41	21-229	39
AS4-416	55	18-827	41	21-284	35
7-15	55	18-835	43	21-287	45
8-147	33	18-854	35	21-295	33
8-149	37	18-873	45	21-310	35
8-150	55	18-907	39	21-315	45
NU13	53	18-920	37	21-317	45,47
14-362	39	18-925	39	21-321	33
14-363	39	18-929	45	21-322	43
14-364	43	18-930	45	21-336	45
14-365	41	18-931	45	21-337	45
14-366	43	18-934	37,43	21-360	41
14-399	33	18-945	45	21-366	41
14-536	41	18-949	43	21-379	41
16-288	33	18-958	39	21-407	45,47
16-289	33	18-959	39	21-414	35
16-291	33	18-966	45	21-440	45,47
16-292	33	18-967	39	21-449	33
16-297	33	18-968	39	21-450	49
16-334	33	18-982	39	21-451	49
16-398	33	18-984	43	21-452	49
16-405	37	18-989	55	21-453	49
16-406	37	18-996	39,43	21-454	51
16-407	51	18-997	35	21-455	53
16-408	49	18-1047	33	21-455-1	53
16-411	33	18-1076	35	21-456	51
16-412	33	18-1077	35	21-457	41
16-413	51	18-1087	45	21-458	47
NU16	55	18-1088	35	21-459	55
17-124	45	18-1089	47	22-175	37
17-178	47	18-1112	43	22-195	35
18-39	43	18-1117	37	22-205	45
18-71	39	18-1120	51	22-219	45
18-272	39,45	18-1121	53	22-221	35
18-280	41	18-1124	49	22-224	45,47
18-286	37	18-1126	51	22-235	41
18-330	35,37,45	18-1127	53	22-238	37
18-375	45,47	18-1128	45,47	22-251	37
18-391	39	18-1131	47	22-266	41
18-392	41,45	18-1133	47,49	22-342	51,53
18-533	37	18-1135	47	22-347	45,47
18-547	37	18-1136	47	22-351	49
18-562	41	18-1137	51	24-338	45
18-619	41,45	18-1139	37	25-11	39
18-626	39,45,49	18-1140	37	26-147	35
18-629	55	18-1142	53	26-163 A	41
18-634	43	18-1147	53	27-155	43
18-730	39,43	18-1148	49	27-168	43
18-732	41	20-34	41	27-169	39
18-738	33	20-60	35	27-189	43
18-745	41	20-80	39	28-7	51
18-747	41	20-81	39	28 B	51
18-750	33,37,49, 51	20-98	35	30-96	55
18-752	37	20-109	45	32-191	33
18-786	35,37	20-123	45	32-192	33
18-800	39	20-127	39	32-209	37
18-809	41	20-128	41	32-311	33
18-814	45	20-151	49	32-312	33
18-816	37	20-153	53	33-168	43
18-818	45	20-154	49	34-35	43
18-819	41	20-155	49	34-47	43
		21-96	41	34-53	43

NUMERICAL INDEX OF PARTS

<u>Part No.</u>	<u>Page No.</u>	<u>Part No.</u>	<u>Page No.</u>	<u>Part No.</u>	<u>Page No.</u>
34-103	49	46-135	41	94	47
34-104	43	46-137	45	99-316	45
35-15	45	46-138	45	99-345	35
35-16	41	46-162	41	99-353	45
35-17	41,47	46-203	47	99-359	51
35-20	43	46-204	47	99-360	49
36-21	43	46-207	41	99-363	49
T38	47	46-208	43	102-10	37
39-92	39	46-209	51	108-9	55
39-107	43	49-33	43	110-205	45
39-131	43	50-215	33	110-206	45
39-143	43	50-298	47	110-446 A	37
39-151	43	50-299	47	110-447	37
40-38	45,47,49, 51,55	50-310	55	110-448	49
40-63	39	50-311	53	110-449	55
40-101	33	50-312	53	111-3	49
40-135	39,43	50-313	51	115-106	41
40-143	41	50-314	51	115-107	35
40-168	41	50-315	47	115-108	45
40-169	39	50-316	55	115-168	47
40-170	37	50-318	51	115-169	45
40-181	53	50-319	55	115-171	33
40-188	35	51-20	39	115-172	39
40-198	41,53	WR56	53	115-173	53
40-202	51	WR57	53	115-174	53
40-204	47	57-23	39	115-175	41
40-206	49,51	57 WB	35	115-176	47
40-C-193	49	58-39	39	115-177	55
41-41	35	59-6	53	115-184	53
41-47	39	61-33	35	115-185	53
41-49	35	61-80	43	117-39	39
41-53	35	61-89	35	117-40	39
42-34	41	63-32	39	119-88	37
44-288	39	68-21	35	119-89	35
44-334	39	68-22	35	122-53	53
45-288	45	69-16	45	122-54	53
45-290	45	69-17	45	122-56	55
45-327	41	69 H	37,47,53	122-58	43
45-332	45	70-50	43	122-60	53
45-333	33	70-79	49	130-12	55
45-335 A	39	71-74	39	131-C163-1	53,55
45-346	45	71-92	41	131-C163-2	33
45-347	45	71-112	45,51	137-19	39
45-348	41	71-119	45	137-158	49
45-404	41	71-123	37	137-159	53
45-434	35	71-124	41,47	137-160	53
45-481	47	73 A	53	138-15	41
45-484	47	74-5	49	141-4	33
45-490	41	75-264	51	142-6	43
45-493	35	75-265	51	144-25	33
45-494	47	75-266	53	144-33	53
45-495	39	75-267	35	155-14	45
45-496	51	75-268	47	157-10	45
45-497	51	75-270	53	157-11	47
45-498	33	75-274	51	157-13	41
45-499	47	75-275	51	157-15	37
45-502	47	76-20	49	157-16	37
45-503	41	77-1	53	158-11	45
45-504	47	SB79	37	158-29	45
45-505	47	79-37	39	162-22	53
45-507	43,55	89-64	47,51,53	164-39	43
		89-65	43	164-40	43

NUMERICAL INDEX OF PARTS

<u>Part No.</u>	<u>Page No.</u>	<u>Part No.</u>	<u>Page No.</u>	<u>Part No.</u>	<u>Page No.</u>
164-41	43	660-400	55	21261 M-440	55
166-7	39	660-401	55	21657 E	37
166-14	45	660-403	55	21697 AE	55
180-4	43	660-415	53	21697 AF-32	55
SC181	53	660-615	55	22541 A	51
182-17	37	660-648	37	22542	45,47
190-2 L	39	660-653	51	22548	37
190-3 L	43	666-19	39	22564	51
197-1	53	670 B-10	55	22581	47
CS231	37	670 B-12	55	22585 A	43
CS303-1/2	41	670 B-50	55	22596	47
CS333	53	670 E-159	55	22635 C-12	53
SC333 A	55	671-44	55	22637 C	55
CS337	33,45,47	671 D-5	55	22637 N-32	47
407-15	55	671 D-7	55	22640 H-64	55
408-150	55	671 F-7	55	22640 H-224	53
413	53	787 L	33	22642 K-32	55
421 D-34	53	815 L	47	22642 K-48	55
430-63-7	45	835 L	41,47	22651 ED-6	41
432-198	37	907	47	22652 E-20	37
432-263	35	1003 L	33,39	22653 B-10	41
433-139	39	1005 L	33,39,43	22653 E-14	41
434-40	43	1009 L	33,39	22660 A-48	47
434-101	43	1022 L	39	22743	47,53
434-102	43	1025 L	39	22747 A	39,49,51
434-104	43	1029 L	43	22756 B	55
439-153	45,47	1158 L	33,41	22757	33
444-334	39	1160 L	33,37,45	22768	49
445-286	41	1183 L	35	22768 B	33
445-298	39	1185 L	41	22768 L	51
445-349	43	1189 L	45	22810	53
445-370	41	1206 L	41	22874	51
445-405	41	1220 L	33,55	22892 A	39,55
446-136	45	1221 L	37	22894 P	33,47
447-142	39	1235 L	33	22894 W	45
447-143	49	1316 L	37	22894 X	43,55
458-39	39	1333 L	39	28602 AS-18	55
461-87	53	1731	45	28602 AS-22	55
461-95	53	1776 L	47	28604 P	53
CS462	39	RM2791-2	49	28741 H	55
468-21	35	RM2805-5	51,53	28742 AG	55
468-22	35	RM2813-3	55	29480 DP	53
475-59	49	RM2813-7	55	29480 RT	55
475-260	49	RM2997 D	55	29480 RV	55
475-261	49	RM3306-2	55	29480 RW	55
475-262	49	RM3320-1	55	35794 A	47
475-263	49	RM3525	55	39583 A	55
475-264	49	RM3789-6	55	41358	33
475-274	49	4115-104	41	43433 Q	39,49
478-10	39	4124-50	39	51170 D	47
478-27	39,43	4124-62	39	51295 B	53
643-296 Blk	49	4124-63	49	51758	37
651-20	55	4186-1	53	53634 C	51
651 B-24	55	4187-3	35	56383 K	55
652-16	41	9937	51	60038 K	35
652-20	55	12538	45,47	60078 Z	53
652 A-20	55	12934 A	33,39	61292 H	35
652 E-6	53	12957 E	33,55	61470 D	37
652 N-14	39,47	15438 C	35	62271 C	35
660-219 W	51	21104 N-6	55	63470 A	51
660-352	55	21201	53	63495 B	51
660-397	55	21233 FB	55	80265	45



The best mechanic has the right tools.

You've probably seen him in action. An operator complains about her thread always breaking. The mechanic, after checking the threading, the needle, etc., simply opens his bag and produces a triangular oil stone that smooths out a little nick in the rotary hook. And the problem's solved.

Having the right tool or gauge when you need it makes all the difference when machine maintenance is necessary. That's exactly what the new tool, gauge and technical information brochure from the Union Special Technical Training Center is all about.

Not only do you get a comprehensive list of tools and gauges chosen for their effective use in actual sewing room conditions, but you also get a guide to proper lubrication of industrial sewing equipment, a metric conversion chart, information on machine maintenance systems, and a description of the courses offered at the Technical Training Centers.

Send for your FREE tool brochure today!

Union Special Corporation
12005 4th Street
Huntley, IL 60142



Name _____ Title _____

Company _____

Address _____

City _____ State _____ Zip _____

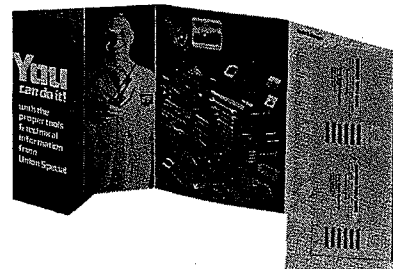

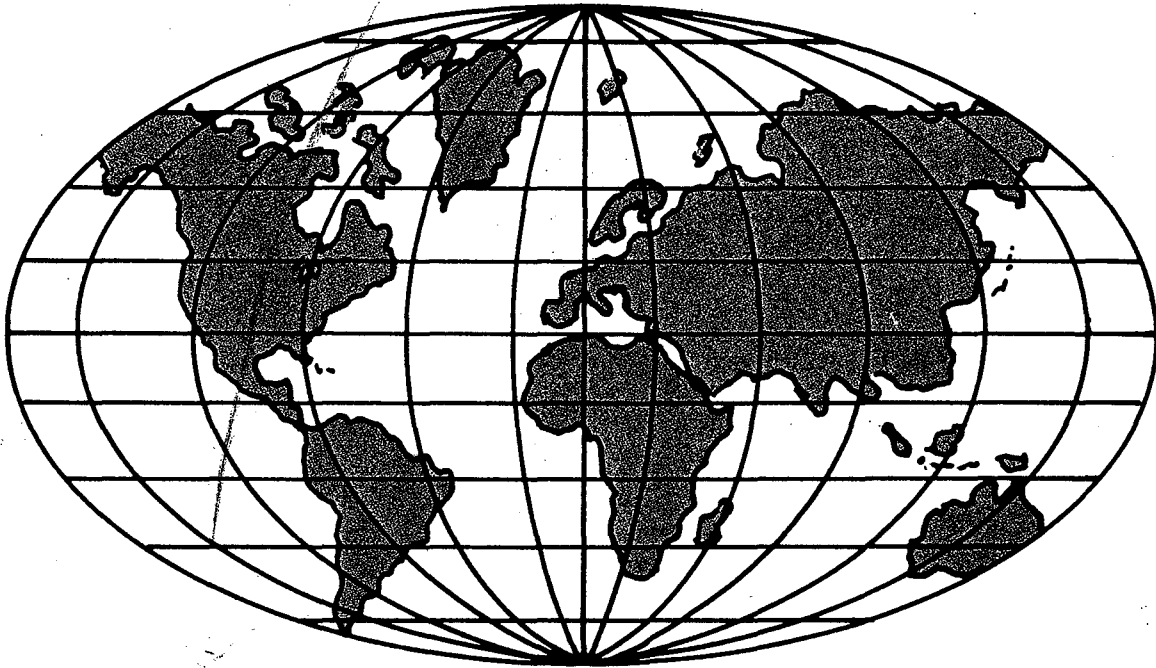

WORLDWIDE SALES AND SERVICE

UNION SPECIAL maintains sales and service facilities throughout the world. These offices will aid you in the selection of the right sewing equipment for your particular operation. UNION SPECIAL representatives and servicemen are factory trained and are able to serve your needs promptly and efficiently. Whatever your location, there is a UNION SPECIAL representative to serve you. Check with him today.

It is important to remember that LEWIS AND COLUMBIA machines are also products of UNION SPECIAL, thus offering the industry the most complete line of the Finest Quality sewing machines.

Norcross, GA
Chicago, IL
Dallas, TX
Commerce, CA
New York, NY
Philadelphia, PA
Woburn, MA
Opa-Locka, FL
Montreal, Quebec
Toronto, Ontario
Catano, Puerto Rico
Brussels, Belgium
Leicester, England
Paris, France
Stuttgart, W. Germany
Hong Kong
Other Representatives throughout
all parts of the world

 **Union Special**[®]
Finest Quality Industrial Sewing Equipment

Union Special Corporation, 400 N. Franklin Street, Chicago, IL 60610, U.S.A.
Union Special, GmbH, Schwabstrasse 33, D-7000 Stuttgart 1, West Germany.