



Union Special
INDUSTRIAL SEWING EQUIPMENT

**STYLES ADJUSTING INSTRUCTIONS AND
ILLUSTRATED PARTS LIST**

16-100

16-100H

16-260

16-265

LOCKSTICH BLINDSTITCH MACHINES

16-290

16-400

16-410B

16-410T

16-420

**CATALOG
NO. 194-6**

**FIRST
EDITION**

FIRST EDITION

© 1962

PRINTED 1996 IN USA

INFORMATION SUBJECT TO CHANGE WITHOUT NOTICE

© UNION SPECIAL CORPORATION ALL RIGHTS RESERVED IN ALL COUNTRIES.

FOREWORD

The Union Special Lewis Class 16 offers a complete line of two thread lockstitch blind stitch machines, universally demanded by manufacturers when quality is a first consideration.

All parts are made by precision methods insuring complete interchangeability.

It is our constant aim to furnish carefully prepared information which will enable the customer to secure all possible advantages from the use of Union Specials. The following pages contain valuable operating and adjusting data, and illustrate and describe the parts for Class 16.

Union Special representatives will be found in all manufacturing centers to cooperate in planning and estimating requirements.

Union Special MACHINE COMPANY

Engineering Department

IDENTIFICATION OF MACHINES

Each Union Special Lewis machine carries a style number, which, in this class of machines, is stamped in the style plate on the front of the column.

The serial number of each machine is stamped in the main frame at the left upper main shaft bearing.

APPLICATION OF CATALOG

This catalog applies specifically to the styles of machines listed herein. All references to direction, such as right and left, forward and back, etc., are taken from the operator's position while seated at the machine.

The operating direction of the handwheel is away from the operator.

DESCRIPTION OF MACHINES

High Production, Two Thread, Single Curved Needle, Lockstitch, Blindstitch, Cylinder Base Machine. Non-skip 1 to 1 Stitch. Overcast or Straight Stitch. Calibrated Penetration Adjustment. Lower Feed. Knee Lifter for Inserting and Removing Work. Maximum Work Space to Right of Needle 10 Inches.

- 16-100 Single needle machine for hemming medium weight trouser cuffs, ladies' suits and all types of knit garments. Particularly desirable for knitted dresses. Also used for under felling coat collars or felling tape edges and bridle tape. Ideal for alteration rooms or small factories. Will handle cylindrical work such as trouser cuffs. Machine produces overcast stitch. By removing spreaders, machine will sew straight lockstitch. Work support plate not included. Needle travels right to left and penetrates at an angle of 45° to line of feed.
- 16-100 H Single needle machine, similar to 16-100 except equipped for felling under collars on overcoats and similar heavy weight garments. Removable work support plate included.
- 16-260 Single needle machine for felling sleeve linings to sleeves at cuffs on tropical and medium weight suit coats and topcoats. Machine cylinder fitted with end cover for quick inserting and removal of sleeves and linings. Medium sleeve diameter 4 3/4 inches. Work support plate not included. Needle travels left to right and penetrates at an angle of 15° to line of feed. Sewing straight lockstitch without spreaders is possible, but not generally recommended for 15° machines.
- 16-265 Single needle machine, similar to 16-260 except equipped for felling sleeve linings to sleeves at cuffs on medium and heavy weight overcoats, car coats and similar garments. Work support plate not included.
- 16-290 Single needle machine for felling wigan or dummy strip sleeve lining to coat sleeves of men's sport or suit coats of light and medium weight materials. Machine cylinder fitted with end cover for quick inserting and removal of work. Minimum sleeve diameter 4 3/4 inches. Work support plate not included. Needle travels right to left and penetrates at an angle of 15° to line of feed. Sewing straight lockstitch without spreaders is possible, but not generally recommended for 15° machines.
- 16-400 Single needle machine for felling under collars on men's suit coats and topcoats of light and tropical weight materials. Includes removable work support plate. Needle travels right to left and penetrates at an angle of 25° to line of feed.

DESCRIPTION OF MACHINES (Continued)

- 16-410 B Single needle machine for felling medium and heavy weight bellows facings and pockets in topcoats and overcoats. Includes removable work support plate. Needle travels right to left and penetrates at an angle of 15° to line of feed. Sewing straight lockstitch without spreaders is not recommended on 15° machines.
- 16-410 T Single needle machine for felling bottom to waistband curtain on trousers, slacks and skirts of heavy materials producing hand felled effect. Includes removable work support plate. Needle travels right to left and penetrates at an angle of 15° to feed. Sewing straight lockstitch without spreaders is not recommended on 15° machines.
- 16-420 Similar to 16-100 except to sew printing press felt ink rolls. Removable work support plate included. Needle travels right to left and penetrates at an angle of 90° to line of feed.

OILING

These machines should be oiled twice daily, before the morning and afternoon starts. Use a good grade of straight mineral oil of a Saybolt viscosity of 200 to 250 seconds at 100° Fahrenheit.

Most of the oiling places on these machines are readily identifiable because of the fact they are painted red. However, reference to the oiling diagram, Fig. 1, on Page 6, will be beneficial.

Please note that it will be necessary to remove head cover, cylinder end cover, and to tilt the machine back from the sub-base to reach some of the oiling places.

Referring to the oiling diagram, it will be noted that there are two lubrication points marked "A", and one marked "B".

The two points "A" are for the needle bearings on the upper main shaft, and are lubricated with a light grease about once a week. Tubes of grease may be ordered from Union Special under part No. 61-81.

Point "B" on the diagram refers to the cover over the hook driving gears, which are lubricated with a standard wheel bearing grease. Periodically, the cover should be removed and the grease replenished, if necessary.

SPEED

The recommended speed of these machines is 1500 R. P. M.

NEEDLES

Use only genuine Union Special Lewis needles. They are stamped with the word "Lewis" on the shank.

Needles for the Lewis Class 16 machines are available in all the required sizes in both uniform blade and ball eye.

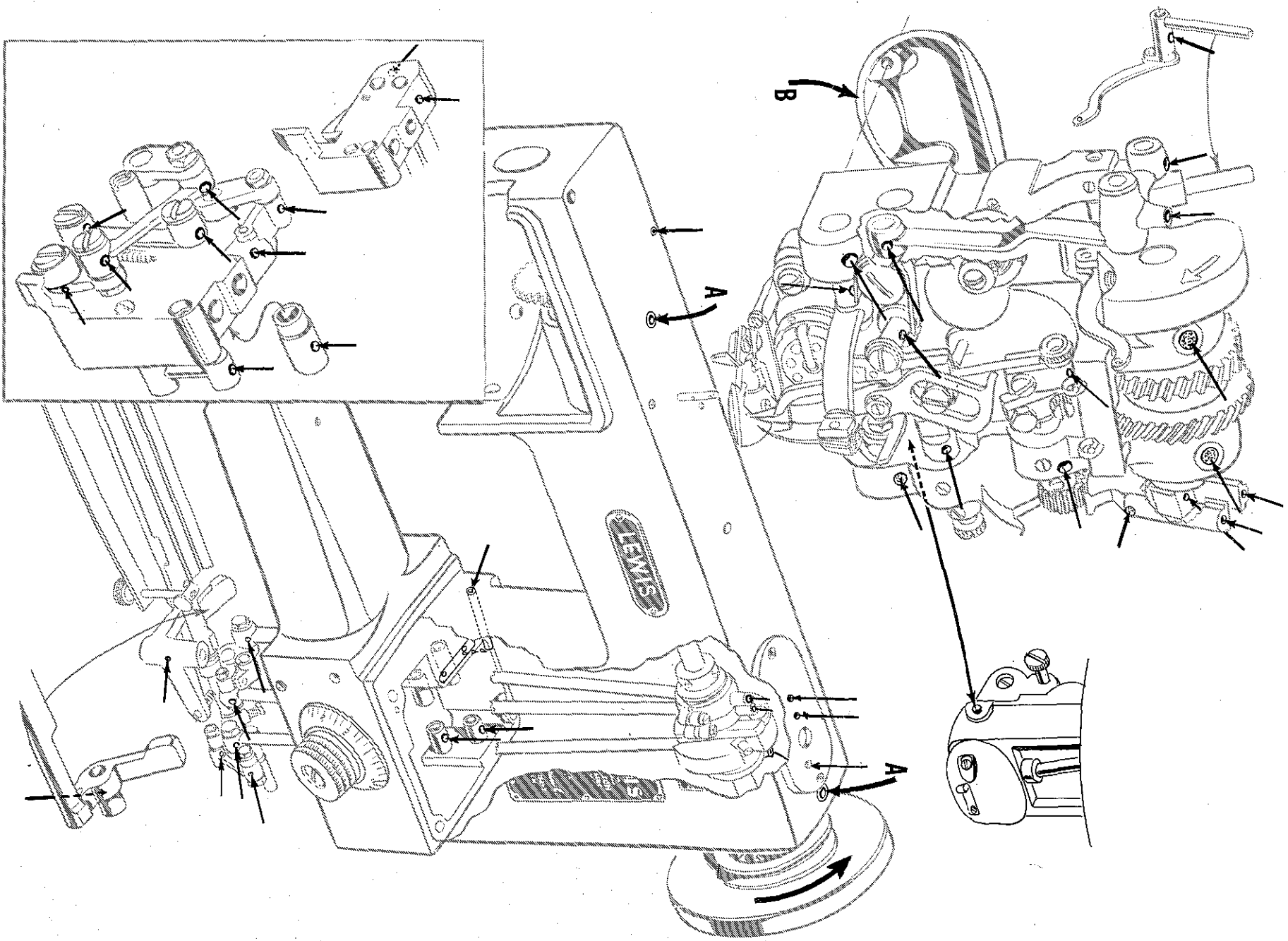

Fig. 1

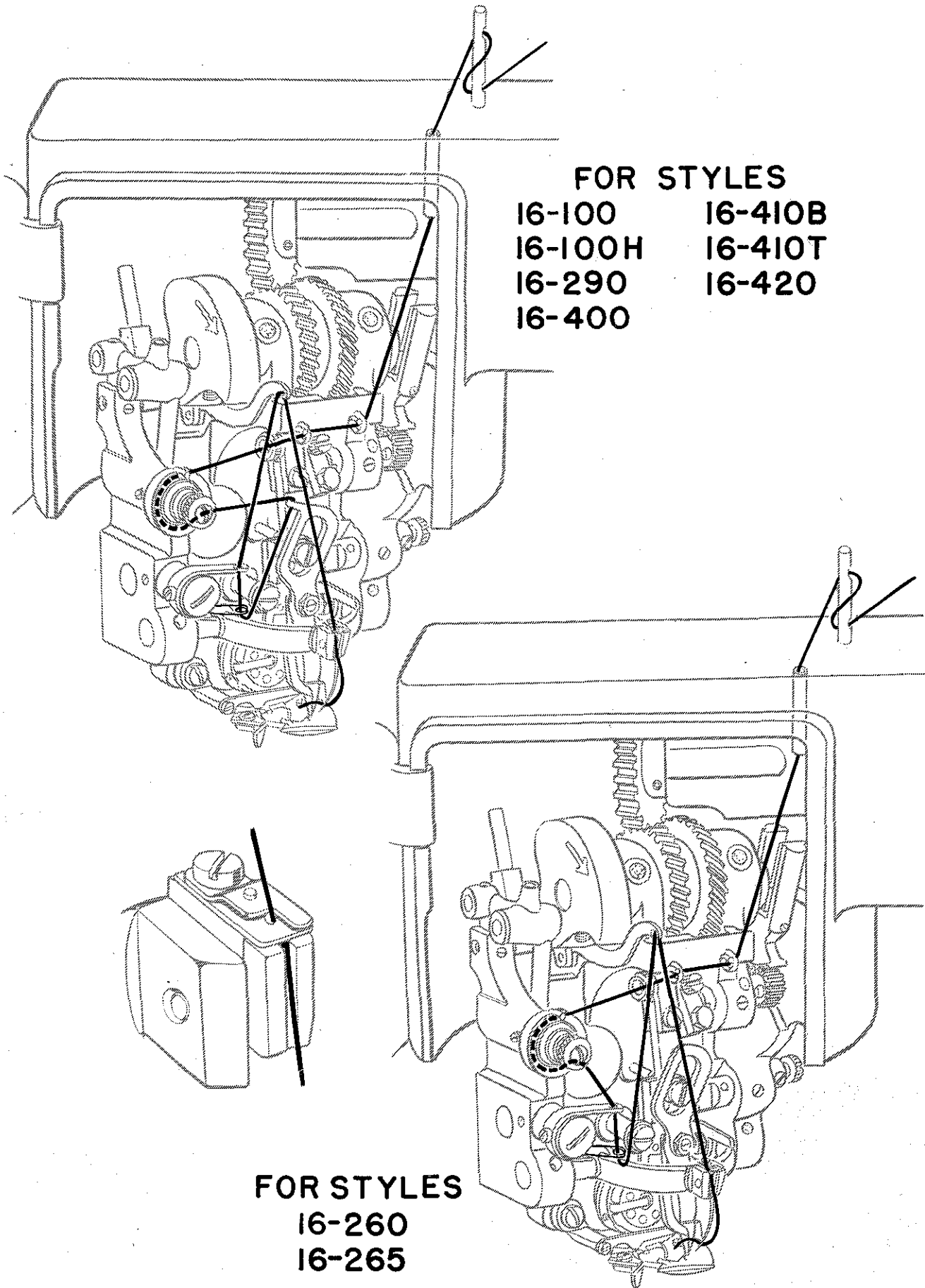

Fig. 2

NEEDLES (Continued)

The following types and sizes are available:

Uniform Blade	Blade Dia.	Ball Eye	Blade Dia.
29-123	.030"	29-132 1/2	.025"
29-123 1/2	.035"	29-133	.030"
29-124	.040"	29-133 1/2	.035"
29-124 1/2	.045"	29-134	.040"
		29-134 1/2	.045"

Select a needle of the proper type and size for the material being sewn. Be sure that the eye is large enough to allow free passage of the thread or yarn used.

Immediately discard any needle which may have a hooked or blunt point.

To have needle orders promptly and accurately filled, an empty container, a sample needle, or the type number should be forwarded. A complete order would read: "100 Needles, Type 129-133 1/2".

THREADING

Thread machines in accordance with threading diagram, Fig. 2, on Page 7. Please note that Styles 16-100, 16-100 H, 16-290, 16-400, 16-410 B, 16-410 T, 16-420 are threaded in accordance with the upper diagram, and Styles 16-260 and 16-265 with the lower. The diagram for Styles 16-260 and 16-265 is not pictorially accurate in that these two Styles are left hand machines, but for the purpose of tracing the threading, it will suffice.

ADJUSTING

REMOVING EXCESS PLAY IN CONNECTING RODS

Access to the connecting rod adjusting screws is through the opening in the top of the arm (Fig. 3). Remove arm cover plate, and tighten screw (A) in plunger drive connecting rod (B) until machine begins to bind while handwheel is being turned in operating direction. Then, loosen screw until machine again turns freely. Repeat same operation with feed elevating connecting rod (C) and feed driving connecting rod (D). Replace arm cover.

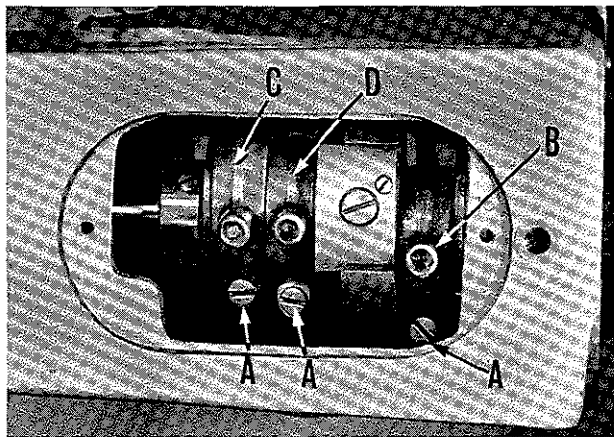

Fig. 3

TIMING NEEDLE TO THE PLUNGER

The needle should be timed so that, on its downward stroke, it is 1/4 inch from the center of the plunger when the plunger reaches its highest point of travel. To accomplish this adjustment, loosen the screws (A, Fig. 4) in the driving gear (B) and remove the gear. Turn the handwheel in operating direction until the plunger just reaches its highest position. Do not continue to turn the handwheel after the plunger has first reached its highest position. Now, turn the needle crank (C) in the direction of its arrow until the needle, when on its downstroke, is within approximately 1/4 inch of the center of the plunger.

Then, replace driving gear (B) on the main shaft, line up the spot screw with the spot on the shaft, and re-tighten screws (A).

TIMING THE HOOK

Turn the handwheel in operating direction until the needle has reached the forward end of its travel and returned 3/32 inch. At this position, the point of the hook should be over the center of the needle. To obtain this adjustment, remove hook gear cover on the back of the head to expose the gears (Fig. 5). Loosen screws (A) in gear (B) and turn gear (C) in the required direction to position the point of the hook over the center of the needle. Re-tighten screws (A).

SETTING HEIGHT OF HOOK

The point of the hook should be set as close to the needle as possible without striking it. To make this adjustment, loosen screws (D and E, Fig. 5) and remove gear (C), exposing hook bushing flange (B, Fig. 6). Loosen screw (A) and rotate the hook bushing flange (B) in the required direction to position the hook point as described above. If the hook bushing flange cannot be turned far enough to secure this setting, remove screw (A) and place it in the alternate hole in the casting to secure more adjustment. Re-tighten screw (A).

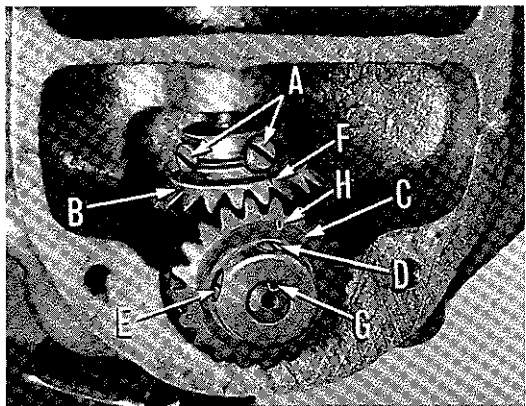

Fig. 5

TIMING THE BOBBIN CASE RELEASE

Turn the handwheel in operating direction until the needle carrier (A, Fig. 7) reaches the highest point of its travel. (Note: The photograph (Fig. 7) does not show the needle carrier in this position, so that the bobbin case and bobbin case release can be seen.)

At this point, the angular projection on bobbin case release lever (E) should be bearing against the extension of the bobbin case release (C) so that there is a clearance of about 1/32 inch between bobbin case (B) and the point of the release (C).

To obtain this adjustment, loosen nut (D) and move bobbin case release lever (E) up or down as required. Re-tighten nut (D).

ADJUSTING THE LOOPER AND SPREADER

When properly adjusted, the points of the looper and spreader must move freely without any interference with the presser foot, feed plate, bobbin case retainer, needle, or needle carrier.

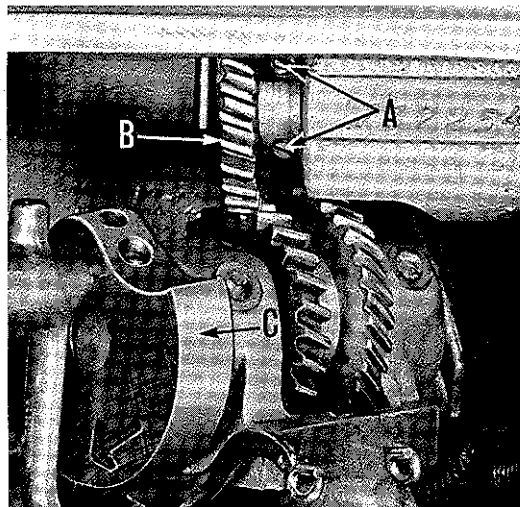

Fig. 4

Turn handwheel in operating direction until timing mark (F, Fig. 5) on gear (B) appears over the hook shaft. Replace gear (C) so that spot screw (D) aligns with "V" groove (G) in hook shaft and turn screw down lightly. Turn gear (C) and hook shaft until timing line (H) on gear (C) aligns with timing line (F) on gear (B).

Re-engage gears (B and C) and tighten screws (D and E) making sure that all end play is removed. Replace gear cover on back of head.

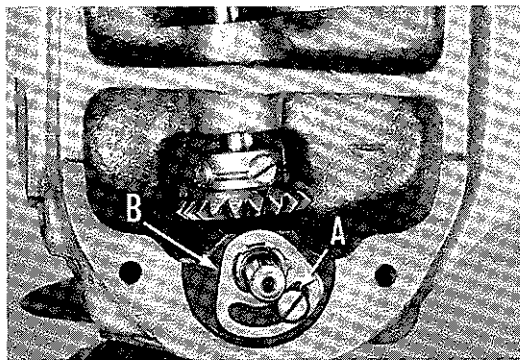

Fig. 6

ADJUSTING THE LOOPER AND SPREADER (Continued)

To adjust the looper and spreader mechanism to the right or left, loosen set screws (A and B, Fig. 8) and move the whole mechanism in the required direction. Re-tighten set screw (A), and turn handwheel slowly in operating direction to remove any binds, and then, re-tighten set screw (B).

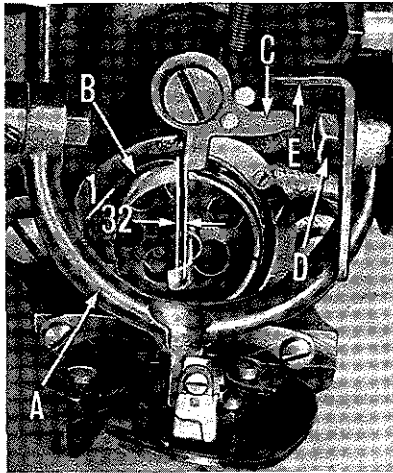

Fig. 7

To adjust the looper and spreader mechanism up or down, loosen screw (C) and move the mechanism in the required direction by pulling out or pushing in on the knurled stud (D). Re-tighten screw (C).

To adjust the looper and spreader mechanism in or out, loosen screw (B) and turn the eccentric bushing (E) in the required direction by placing a screw driver in one of the two oil holes in the bushing and turning. Turn handwheel slowly in operating direction to remove any binds that may appear. Re-tighten screw (B).

A combination of all the preceding adjustments may be necessary to properly adjust the looper and spreader mechanism. It also may be necessary to remove any play or bind that may have developed between gears (F and G) as a result of these adjustments. This can be checked by moving stud (D) back and forth when the looper and spreader mechanism is at its lowest point. At this position, very little play should be observed. To remove any bind or excess play, loosen set screw (A), and turn eccentric bushing (H) in the required direction by placing a screw driver in one of the two notches in the bushing. Turn handwheel slowly in operating direction to remove any binds and re-tighten screw (A).

Turn handwheel slowly in operating direction to check the preceding adjustments to make sure that there is no interference between the looper and spreader mechanism and other parts, and repeat adjustments if necessary.

SETTING THE FEED PLATE HEIGHT AND PRESSURE

Turn handwheel in operating direction until the feed point has reached the lowest point of its travel. At this position, there should be no play between the feed plate and the presser foot.

To make this adjustment, loosen screw (A, Fig. 9) and, with the right hand, hold the feed plate against the presser foot. Then, by holding the feed link (B) with the left hand, push down the feed point until there is 1/32 inch clearance between the block (C) and the plunger bearing block (D). Then, re-tighten screw (A).

Turn handwheel in operating direction until the feed point reaches its highest position, and check to see that the feed point is in the center of the slots in the feed plate. If the feed point is not in proper alignment, loosen screw (A) and turn the feed plate to align the feed point in the slots. Re-tighten screw (A).

The feed plate pressure is adjusted at the factory. If it becomes necessary to change the pressure, turn the knurled screw (A, Fig. 11) clockwise for more pressure and counterclockwise for less.

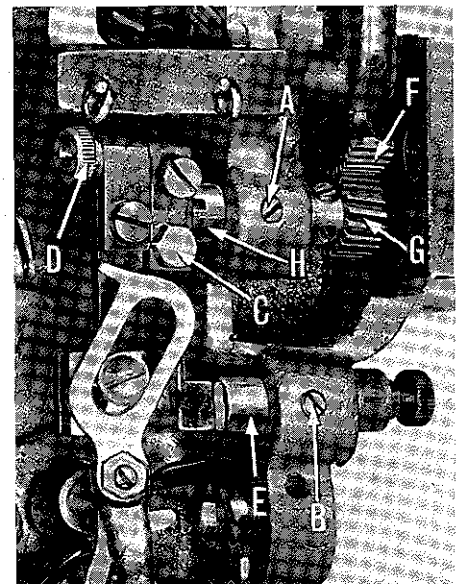

Fig. 8

SETTING THE FEED POINT HEIGHT

Turn handwheel in operating direction until the feed point reaches its highest position and the feed plate reaches its lowest position. At this point, there should be 1/8 inch space between the top of the feed plate and the bottom of the presser foot (Fig. 10). To obtain this adjustment, loosen the machine base locking screw (A, Fig. 12) and lay the machine on its side. Then, loosen screw (B, Fig. 11) and hold link (B, Fig. 10) so that the feed point is pressed up against the bottom of the presser foot. Turn handwheel in operating direction until the feed point reaches its most forward position, and re-tighten screw (B, Fig. 11).

SETTING FEED POINT IN LINE OF FEED

Turn the handwheel in operating direction until the feed point first touches the presser foot. At this point, the front edge of the feed point should be aligned with the front edge of the knurling on the feed plate. To make this adjustment, loosen screw (C, Fig. 11), and, by means of link (B, Fig. 10), move the feed point forward or backward as required. Re-tighten screw (C, Fig. 11). If, in this adjustment, the feed point has to be moved an appreciable distance, repeat the adjustment "Setting The Feed Point Height" in the previous instruction.

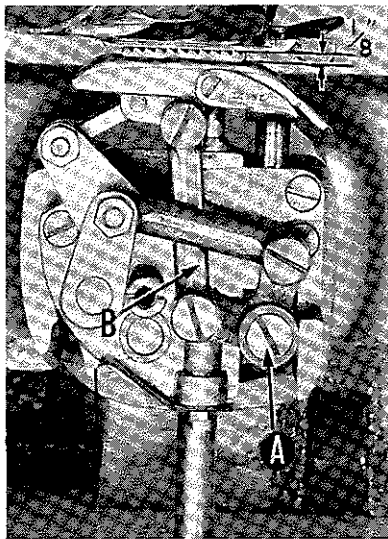

Fig. 10

(B, Fig. 12) after each complete revolution. The knob may be pulled out toward the operator to lift it over the stop. The knob can make three complete revolutions. To make the 1/32 inch adjustment, turn the knob clockwise as far as it will go. Loosen lock nut (D, Fig. 11) and turn screw (E) in the required direction. Re-tighten nut (D).

ADJUSTING AUTOMATIC PLUNGER

Some machines in this class are equipped with an automatic plunger to insure a uniform depth of needle penetration when felling across parts of a garment where there is considerable variation in thickness.

Below the regular or work presenting plunger, which is in the plunger barrel (A, Fig. 14), is the lower plunger (B).

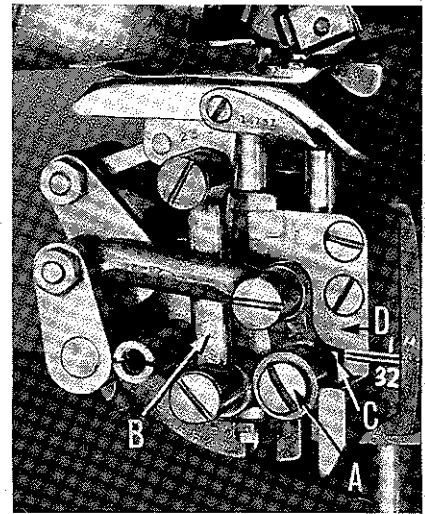

Fig. 9

SETTING THE HEIGHT OF PLUNGER

The height of the plunger is adjusted by turning knob (B, Fig. 12) clockwise to raise the plunger and counter-clockwise to lower it. To provide for the maximum plunger adjustment, there should be 1/32 inch clearance between plunger crank (A, Fig. 13) and plunger block (B) when the adjusting knob (B, Fig. 12) is turned clockwise as far as it will go. Note that there are pins which stop the knob

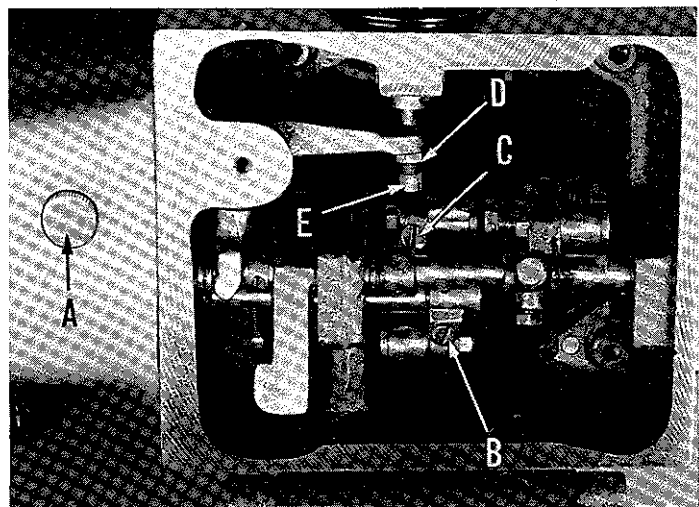

Fig. 11

ADJUSTING AUTOMATIC PLUNGER (Continued)

To adjust the lower plunger in relation to the upper or work presenting plunger, back off the crown adjusting screw (A, Fig. 20) on the presser foot. Loosen knurled adjusting nut (C, Fig. 14) so that the lower plunger (B) does not contact the upper plunger at any time. Set the penetration knob (B, Fig. 12) so that the work presenting plunger is high enough to cause the needle to penetrate the material to the proper depth. Then, turn the penetration knob about 2 or 3 notches higher. With the upper or work presenting plunger at low position, turn the knurled adjusting nut (C, Fig. 14) until the distance between the lower nut (D), on the upper plunger, and the lower plunger (B) is $1/32$ inch.

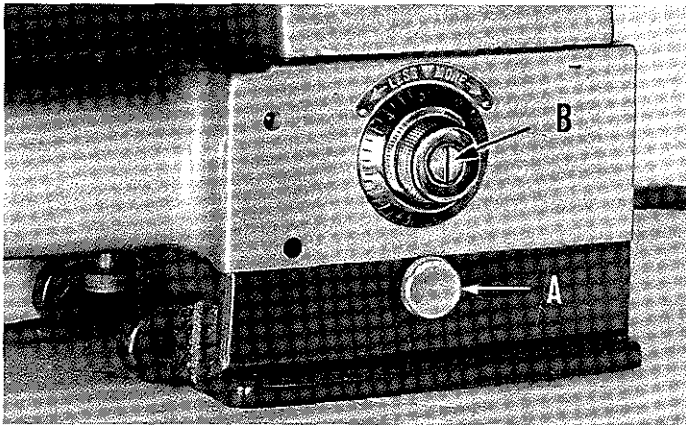

Fig. 12

Turn the crown screw (A, Fig. 20) down, and test sew to see that, when a pocket or pleat is crossed, the amount of needle penetration remains the same.

INSERTING BOBBIN IN HOOK

Turn the handwheel in the operating direction until the needle carrier has reached its highest position and returned about $1/4$ inch.

Open the bobbin case latch (A, Fig. 15), and insert bobbin (B) so that the thread will come off the bottom of the bobbin in the direction of the bobbin case tension spring (C) and through the notch (D) in the bobbin case. Close bobbin case latch. The

tension on the bobbin thread is controlled by turning screw (E) in the required direction. For easier access to this screw, have the needle carrier at high position.

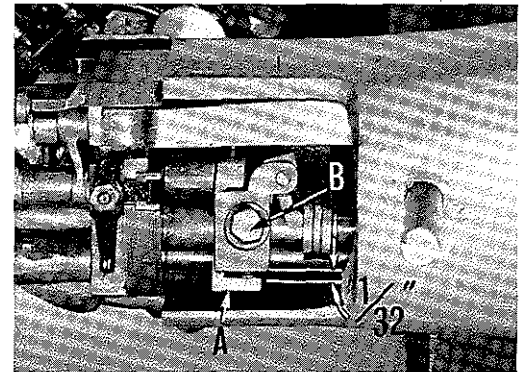

Fig. 13

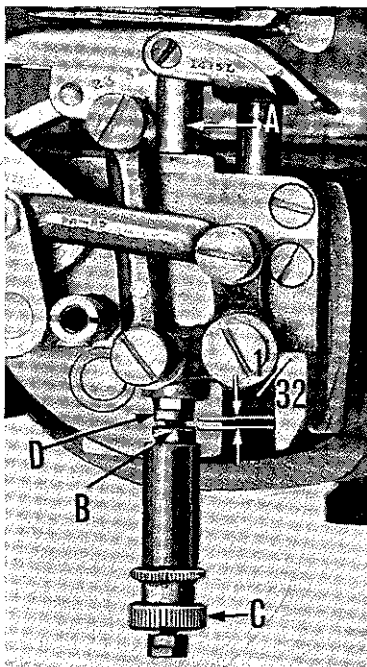

Fig. 14

SETTING THE STITCH LENGTH

This adjustment is made through the access hole in the top of the arm (Fig. 16). Remove top cover and turn handwheel in operating direction until lock screw (A) and adjusting screw (B) are in view. Loosen lock screw (A) and turn adjusting screw (B) in the required direction. Turning the adjusting screw clockwise shortens the stitch and counter-clockwise lengthens it. Re-tighten lock screw (A) and replace top cover.

THREAD CONTROL

Make sure the machine is threaded in accordance with threading diagram (Fig. 2, Page 7), and sew machine under power to check stitch.

THREAD CONTROL (Continued)

If the hook is not catching the needle thread as a result of the needle not throwing up a large enough loop, then the needle carrier should be adjusted. To make this adjustment, turn handwheel in operating direction until the needle carrier is in its most forward position, and, with a wrench, loosen nut (A, Fig. 17) and turn needle carrier driving stud in the required direction. Access to this stud is through the hole in the head casting (B). If the hook is still not catching the needle thread, re-time the hook as previously instructed.

If the needle thread snaps as it passes over the top of the bobbin case, it is an indication that either the tension on the thread controller spring (C) is too great or that the hook is a trifle slow or both. If the tension on the thread controller spring (C) is not great enough, the thread will not come off the hook fast enough with the result that hook will pick up the thread a second time, causing the machine to break thread. To make this adjustment, turn thread controller staff (D) in the required direction.

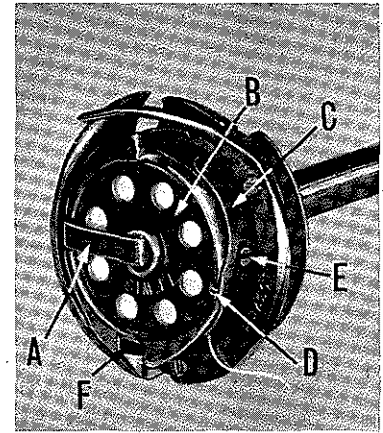

Fig. 15

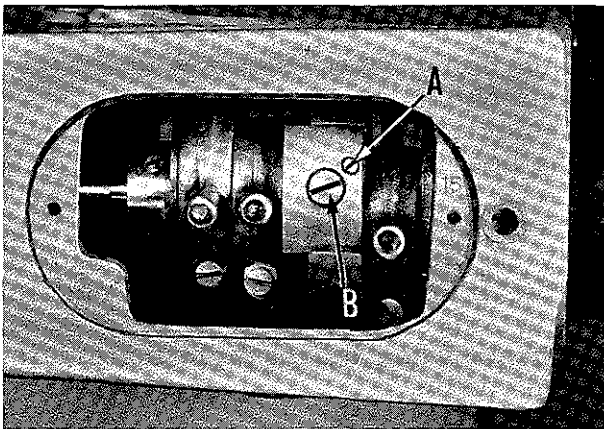

Fig. 16

If it is found that the looper (B, Fig. 18) and spreader (A) are skipping stitches, an adjustment can be made by loosening lock nut (C) and turning the eccentric adjusting stud (D) in the required direction. If further adjustment is required, repeat looper and spreader adjustment in previous instruction.

REMOVING LOOPER AND SPREADER MECHANISM

A straight two thread stitch, instead of an overcast stitch, may be formed by removing the looper and spreader mechanism. This may be done by removing screw (A, Fig. 19) and loosening screw (B), and then removing stud (C). The looper and spreader mechanism can now be removed.

NOTE: The removal of the looper and spreader mechanism is not recommended on 15° machines.

ADJUSTING WIDTH OF BITE

The width of the bite taken by the needle depends on several factors, the most important being the angle of the machine. Thus, a 45° machine will produce a wider bite than a 15° machine, other conditions being equal. The width of bite is also dependent on the depth to which the needle penetrates the material as well as the shape of the top of the plunger.

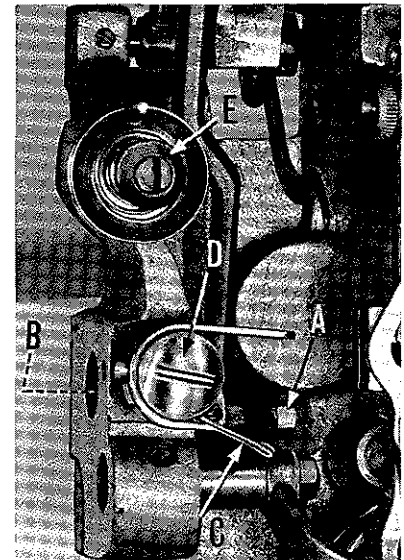

Fig. 17

ADJUSTING WIDTH OF BITE (Continued)

For any given set of these conditions, the width of the bite may be adjusted by moving the edge guide (B, Fig. 20) to the right or left by loosening screw (C). By moving the guide to the left, a wider bite will result, to right acts the reverse.

REMOVING AND REPLACING PRESSER FOOT

Turn handwheel in operating direction until the plunger is in its lowest position, and remove the two screws which hold the presser foot to the head casting. Press knee lifter to release the pressure on the foot and remove foot.

To replace the foot, keep the plunger at its lowest position. Press the knee lifter and place the foot in position on the frame. Replace and tighten the two screws that hold the foot on the head casting, being sure to see that the groove in the bobbin case (F, Fig. 15) fits over the projection

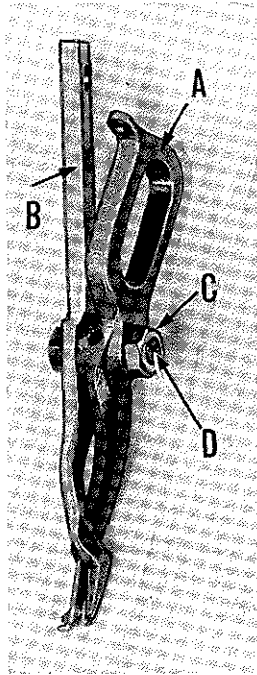

Fig. 18

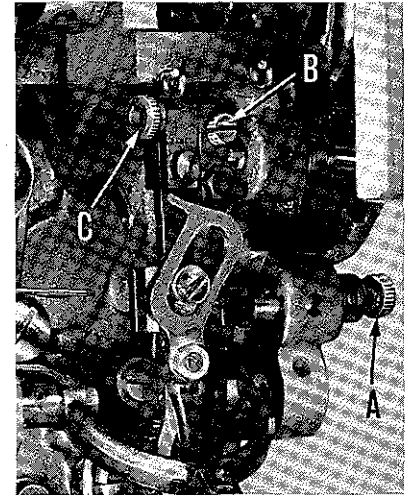

Fig. 19

in the bobbin case retainer (D, Fig. 20) to hold the bobbin in position.

Check to see that the needle guide (E) lines up exactly with the needle. If it does not, loosen screw (F) and turn handwheel slowly in operating direction until the needle passes over the needle guide. This will allow the needle to center the needle guide. Re-tighten screw (F). The needle should now ride in the center of the groove in the guide. This adjustment is especially important when felling light materials in order to obtain accuracy and consistency of penetration.

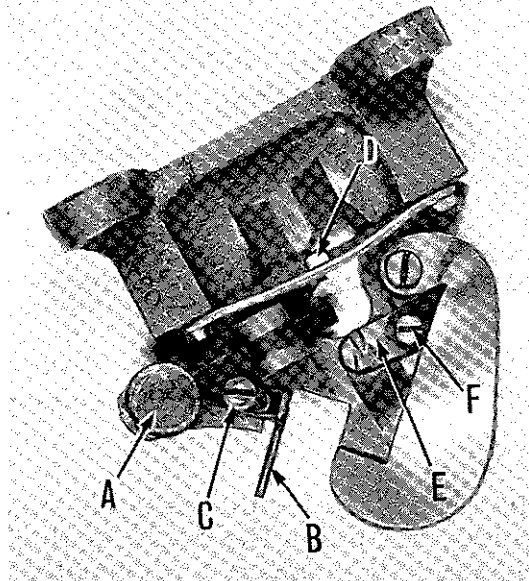

Fig. 20

ORDERING REPAIR PARTS

ILLUSTRATIONS

This catalog has been arranged to simplify ordering repair parts. Exploded views of various sections of the mechanism are shown so that the parts may be seen in their actual position in the machine. On the page opposite the illustration will be found a listing of the parts with their parts numbers, description and the number of pieces required in the particular view being shown.

Numbers in the first column are reference numbers only, and merely indicate the position of that part in the illustration. Reference number should never be used in ordering parts. Always use the part number listed in the second column.

Component parts of sub-assemblies which can be furnished for repairs are indicated by indenting their descriptions under the description of the main sub-assembly. Example:

50	4115-72-3	Plunger Bearing Block, complete, for Styles 16-100, 16-100 H, 16-400, 16-410 B, 16-410 T, 16-420-----	1
51	4121-3	Plunger Frame and Barrel Assembly -----	1
52	1306 L	Screw-----	1
53	16-352	Bushing-----	1

It will be noted in the above example that the plunger bearing block is not listed. The reason is that the replacement of this part individually is not recommended, so the complete sub-assembly should be ordered.

At the back of the book will be found a numerical index of all the parts shown in this book. This will facilitate locating the illustration and description when only the part number is known.

IDENTIFYING PARTS

Where the construction permits, each part is stamped with its part number. Part numbers represent the same part, regardless of catalog in which they appear.

USE GENUINE NEEDLES AND REPAIR PARTS

Success in the operation of these machines can be secured only with genuine Union Special Lewis Needles and Repair Parts as furnished by the Union Special Machine Company, its subsidiaries and authorized distributors. They are designed according to the most approved scientific principles, and are made with utmost precision. Maximum efficiency and durability are assured.

Genuine needles are packaged with labels marked LEWIS *Union Special*. This trade mark is your guarantee of the highest quality in materials and workmanship.

TERMS

Prices are net cash and subject to change without notice. All shipments are forwarded f. o. b. shipping point. Parcel Post shipments are insured unless otherwise directed. A charge is made to cover postage and insurance.

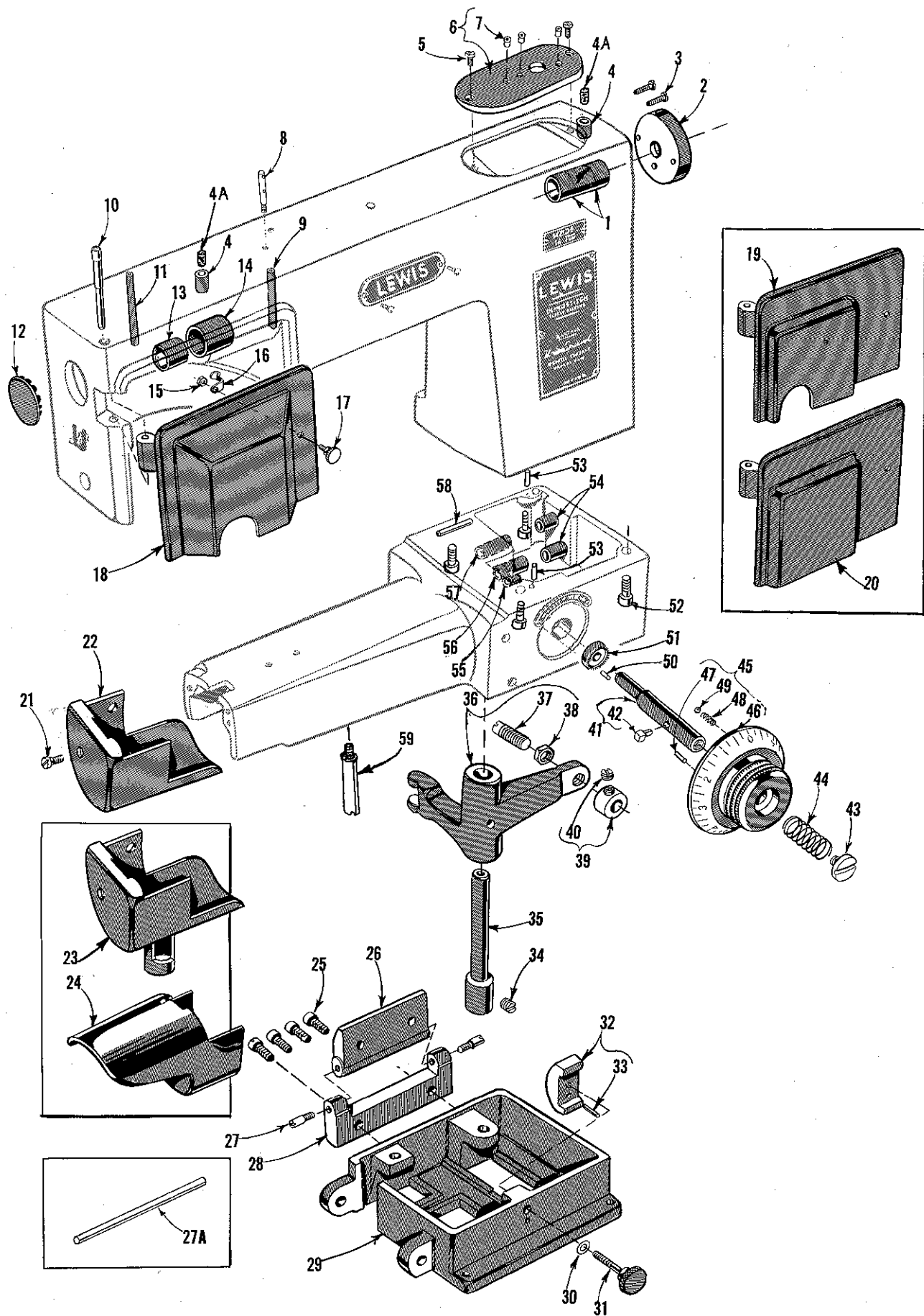

MAIN FRAME, BUSHINGS, COVERS, AND MISCELLANEOUS PARTS

<u>Ref. No.</u>	<u>Part No.</u>	<u>Description</u>	<u>Amt. Req.</u>
1	478-10	Needle Bearing, right -----	2
	16-368	Bushing, on new machines -----	1
2	39-128	Collar -----	1
3	18-957	Screw -----	2
4	125-23	Oil Cup -----	2
4A	666-65	Oil Wick -----	2
5	18-596	Screw -----	2
6	432-279	Cover, complete -----	1
7	61-49	Oil Tube -----	3
8	41-55	Thread Guide -----	1
9	61-47	Thread Tube -----	1
10	22-298	Head Cover Hinge Pin -----	1
11	61-46	Looper Shaft Bearing Oil Tube -----	1
12	89-58	Plug -----	1
13	478-13	Needle Bearing, left -----	1
	16-367	Bearing, on new machines -----	1
14	16-353	Main Shaft Bushing, left -----	1
15	CS231	Nut -----	1
16	21-410	Spring -----	1
17	18-1047	Knurled Screw -----	1
18	32-281	Head Cover, for Styles 16-100, -100 H -----	1
	32-285	Head Cover, for Style 16-420 -----	1
19	32-282	Head Cover, for Styles 16-290, -400, -410 B, -410 T -----	1
20	32-286	Head Cover, for Styles 16-260, -265 -----	1
21	CS313	Screw -----	1
22	32-277	Cylinder End Cover, for Styles 16-100, -420 -----	1
23	32-276	Cylinder End Cover, for Styles 16-100 H, -400, -410 B, -410 T -----	1
24	432-136	Cylinder End Cover, for Styles 16-260, -265, -290 -----	1
25	18-998	Screw -----	4
26	50-263 L	Cylinder Base Hinge Bracket -----	1
27	18-959	Hinge Bracket Pivot Screw -----	2
†27A	14-508	Hinge Bracket Shaft -----	1
28	50-262	Sub-Base Hinge Bracket -----	1
29	3-91	Sub-Base -----	1
30	40-139	Washer -----	1
31	18-1030	Sub-Base Locking Latch Adjusting Screw -----	1
32	51-26	Sub-Base Locking Latch -----	1
33	22-C214-2	Sub-Base Locking Latch Pin -----	1
34	1005 L	Set Screw -----	1
35	14-472	Plunger Regulating Crank Shaft -----	1
36	48-166	Plunger Regulating Bell Crank, large -----	1
37	1192 L	Adjusting Set Screw -----	1
38	20-34	Lock Nut -----	1
39	1173 L	Collar -----	1
40	1137 L	Set Screw -----	1
41	418-1026	Plunger Regulating Screw, complete -----	1
42	22-296	Pin -----	1
43	18-1028	Screw -----	1
44	21-404	Spring -----	1
45	4149-30	Plunger Regulating Knob Assembly -----	1
46	149-30	Plunger Regulating Knob -----	1
47	22-C214-4	Stop Pin -----	1
48	21-237	Spring -----	1
49	79-31	Ball -----	1
50	22-C214-4	Stop Pin -----	1
51	44-301	Notched Disc Plate -----	1
52	18-1045	Screw -----	4
53	22-148	Locating Dowel Pin -----	2
54	1321 L	Plunger Rocker Shaft Bushing -----	2
55	16-379	Plunger Rocker Shaft Bushing, on new machines -----	1
56	16-356	Feed Elevating Rocker Shaft Bushing -----	1
57	16-354	Feed Rocker Shaft Bushing -----	1
58	61-75	Feed Elevating and Feed Rocker Shaft Oil Tube -----	1
59	17-167	Stud, for base -----	1

† NOTE: On new machines two No. 18-959 will be replaced by one No. 14-508.

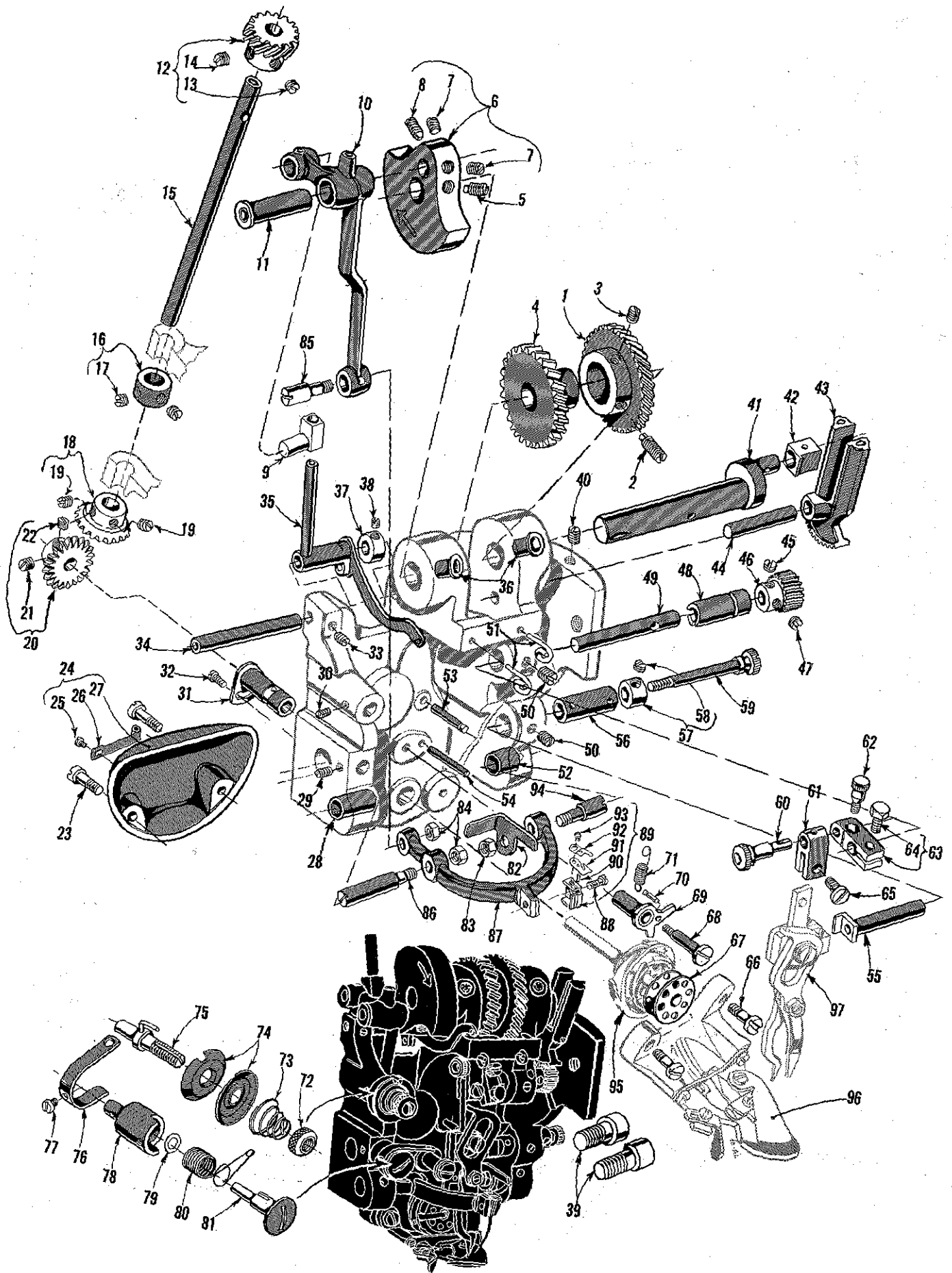

HOOK, LOOPER, SPREADER AND NEEDLE DRIVING PARTS

<u>Ref. No.</u>	<u>Part No.</u>	<u>Description</u>	<u>Amt. Req.</u>
1	1146 L	Hook Drive Gear, for Styles 16-100, -100 H, -260, -265, -290, -400, -410 B, -410 T-----	1
	1146 SL	Hook Drive Gear, for Style 16-420-----	1
2	1002 L-1/2	Spot Screw-----	1
3	1005 L	Set Screw-----	1
4	1143 L	Head Driven Gear, for Styles 16-100, -100 H-----	1
	1142 L	Head Driven Gear, for Styles 16-260, -265-----	1
	27-120	Head Driven Gear, for Styles 16-290, -410 B, -410 T-----	1
	27-1	Head Driven Gear, for Style 16-400-----	1
	1144 L	Head Driven Gear, for Style 16-420-----	1
5	1002 L	Spot Screw-----	1
6	1001 L	Needle Crank-----	1
7	1005 L	Set Screw-----	2
8	1003 L	Set Screw-----	1
9	1023 L	Take-up Lever Slide Block, for Styles 16-100, -100 H, -290, -400, -410 B, -410 T, -420-----	1
	115-28	Take-up Lever Slide Block, for Styles 16-260, -265-----	1
10	1006 L	Needle Carrier Connecting Link, for Styles 16-100, -100 H, -290, -410 B, -410 T-----	1
	46-38	Needle Carrier Connecting Link, for Styles 16-260, -265--	1
	1006 SL	Needle Carrier Connecting Link, for Styles 16-400, -420--	1
11	1004 L	Needle Driving Stud-----	1
12	1024 L	Hook Shaft Driven Gear-----	1
13	1031 L	Spot Screw-----	1
14	1029 L	Set Screw-----	1
15	1026 L	Hook Shaft-----	1
16	1027 L	Collar-----	1
17	1029 L	Set Screw-----	2
18	1028 L	Hook Shaft Driving Gear-----	1
19	1025 L	Set Screw-----	2
20	1030 L	Hook Driven Gear-----	1
21	1029 L	Set Screw-----	1
22	1031 L	Spot Screw-----	1
23	1073 L	Screw-----	2
24	1072 AL	Hook Cover, complete-----	1
25	1075 L	Screw-----	1
26	1074 L	Thread Clip and Cutter-----	1
27	1072 L	Hook Cover-----	1
28	1059 L	Needle Carrier Bearing Stud Bushing, left-----	1
29	LS330	Set Screw-----	1
30	1081 L	Set Screw-----	1
31	416-11	Adjustable Hook Bushing, complete, marked "B"-----	1
32	1170 L	Screw-----	1
33	1020 L	Spot Screw-----	1
34	1019 L	Take-up Lever Shaft-----	1
35	1018 AL	Take-up Lever, complete, for Styles 16-100, -100 H, -290, -410 B, -410 T-----	1
	445-96	Take-up Lever, complete, for Styles 16-260, -265-----	1
	445-234	Take-up Lever, complete, for Styles 16-400, -420-----	1
36	125-23	Oil Cup-----	2
37	1021 L	Collar-----	1
38	1022 L	Set Screw-----	1
39	18-1045	Screw-----	2
40	LS330	Set Screw-----	1
41	1140 L	Head Main Shaft-----	1
42	1149 L	Slide Block-----	1
43	1151 L	Looper Driving Sector, for Styles 16-260, -265-----	1
	28-2	Looper Driving Sector, for Styles 16-100, -100 H, -290, -400, -410 B, -410 T, -420-----	1
44	1080 L	Looper Driving Sector Shaft-----	1
45	1137 L	Set Screw-----	1
46 to 97		See following page	

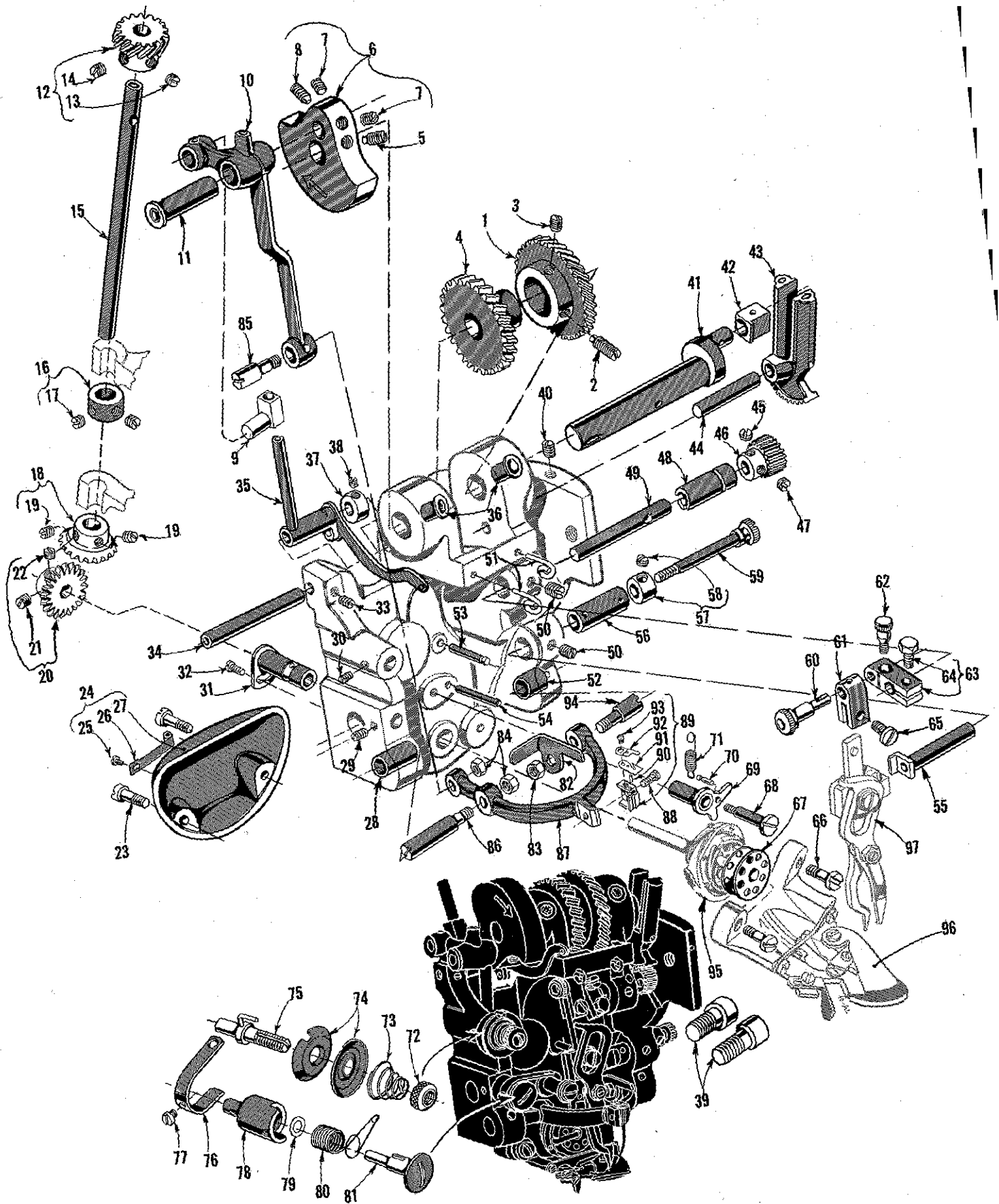

HOOK, LOOPER, SPREADER AND NEEDLE DRIVING PARTS

<u>Ref. No.</u>	<u>Part No.</u>	<u>Description</u>	<u>Amt. Req.</u>
1 to 45		See preceeding page	
46	1152 L	Looper Shaft Driven Gear, for Styles 16-100, -100 H, -290, -400, -410 B, -410 T, -420-----	1
	1153 L	Looper Shaft Driven Gear, for Styles 16-260, -265-----	1
47	1136 L	Spot Screw-----	1
48	16-269	Looper Shaft Eccentric Bushing, for Styles 16-100, -100 H, -290, -400, -410 B, -410 T, -420-----	1
	1156 L	Looper Shaft Eccentric Bushing, for Styles 16-260, -265-----	1
49	14-307	Looper Shaft-----	1
50	1005 L	Set Screw-----	2
51	1181 L	Thread Guide-----	2
52	1060 L	Needle Carrier Bearing Stud Bushing, right-----	1
53	1055 L	Spring Pin-----	1
54	1053 L	Stop Pin-----	1
55	70-70	Sleeve-----	1
56	16-365	Bushing-----	1
57	39-135	Collar-----	1
58	1137 L	Set Screw-----	1
59	18-1060	Knurled Adjusting Screw-----	1
60	17-171	Looper Crank Stud-----	1
61	1161 L	Looper Head Block-----	1
62	18-1059	Clamp Screw-----	1
63	448-177	Looper Crank, complete-----	1
64	18-715	Screw-----	1
65	1158 L	Screw-----	1
66	1073 L	Screw-----	2
67	1047 L	Bobbin-----	1
68	18-719	Bearing Screw-----	1
69	445-251	Bobbin Case Release Lever, complete-----	1
70	1049 L	Spring Pin-----	1
71	1054 L	Spring-----	1
72	20-60	Tension Adjusting Nut-----	1
73	21-284	Tension Spring-----	1
74	1183 L	Tension Disc-----	2
75	1182 AL	Tension Staff, complete-----	1
76	1188 L	Thread Controller Staff Stop-----	1
77	1189 L	Screw-----	1
78	1186 L	Thread Controller Staff Barrel-----	1
79	1185 L	Thread Controller Staff Washer-----	1
80	1187 L	Thread Controller Spring-----	1
81	68-19	Thread Controller Staff-----	1
82	1056 L	Bobbin Case Release-----	1
83	1012 L	Nut-----	1
84	1009 L	Nut-----	2
85	1008 L	Needle Carrier Driving Stud-----	1
86	1010 L	Needle Carrier Bearing Stud, left-----	1
87	1007 L	Needle Carrier, for Styles 16-100, -100 H, -260, -265, -290, -410 B, -410 T, -420-----	1
	118-23	Needle Carrier, for Style 16-400-----	1
88	1014 L	Screw-----	1
89	1432 AL	Needle Clamp, complete, for Styles 16-100, -100 H, -260, -265, -290, -410 B, -410 T, -420-----	1
	430-37-1	Needle Clamp, complete, for Style 16-400-----	1
90	1420 L	Pin-----	1
91	41-28	Thread Guide Plate, lower-----	1
92	1016 L	Thread Guide Plate, upper-----	1
93	1036 L	Screw-----	1
94	1011 L	Needle Carrier Bearing Stud, right-----	1
95		Hook, complete with Bobbin Case - See Page No. 27-----	1
96		Presser Foot, complete - See Page Nos. 31, 33, 35, 37, 39-----	1
97		Looper and Spreader, complete - See Page No. 27-----	1

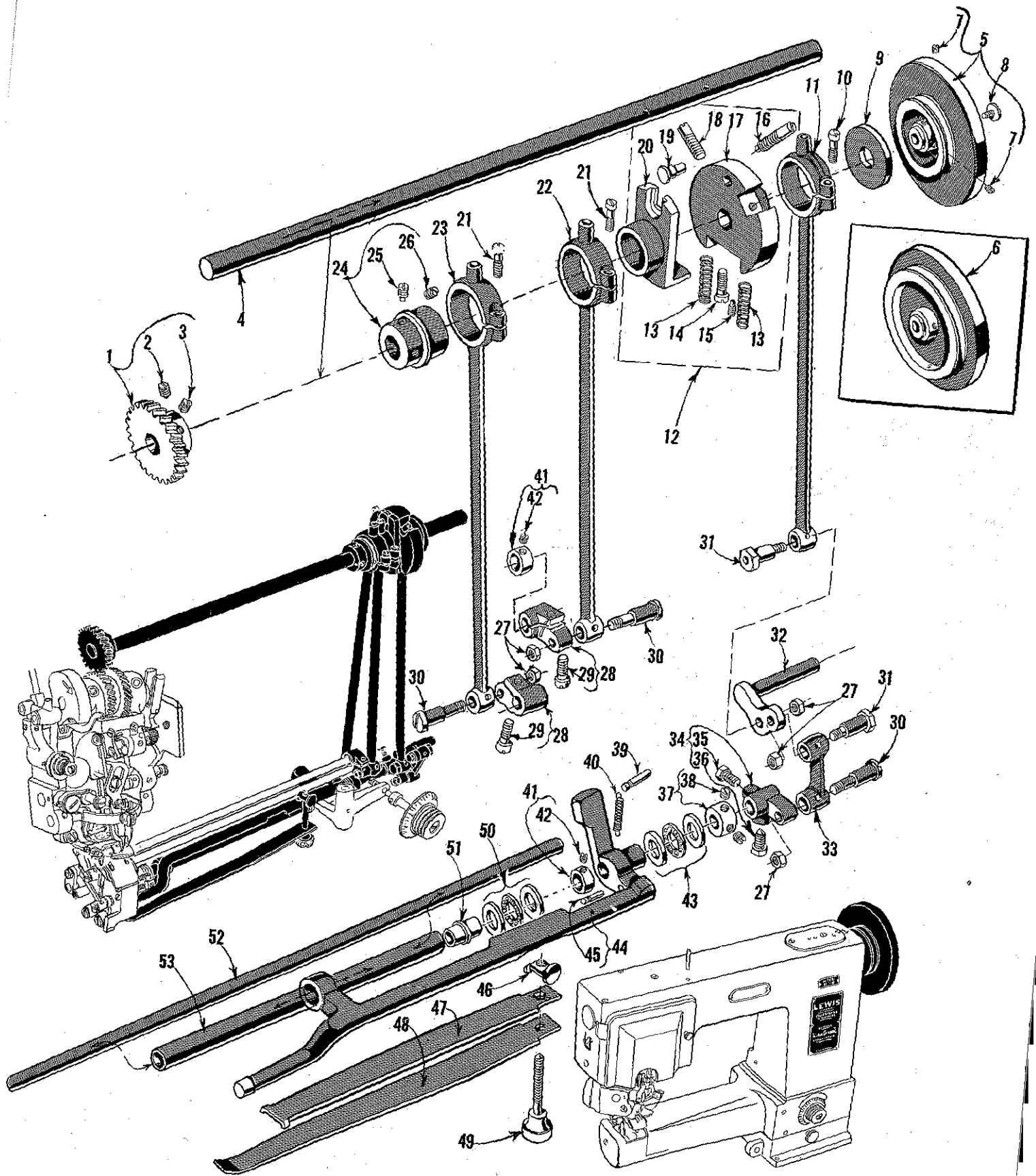

MAIN SHAFT, FEED AND PLUNGER DRIVING PARTS

<u>Ref. No.</u>	<u>Part No.</u>	<u>Description</u>	<u>Amt. Req.</u>
1	1200 L	Gear, for driving head, for Styles 16-100, -100 H-----	1
	427-131	Gear, for driving head, for Styles 16-260, -265-----	1
	27-121	Gear, for driving head, for Styles 16-290, -410 B, -410 T-----	1
	27-2	Gear, for driving head, for Style 16-400-----	1
	1201 L	Gear, for driving head, for Style 16-420-----	1
2	1203 L	Spot Screw, for Styles 16-100, -100 H, -290, -400, -410 B, -410 T, -420-----	1
	18-492	Spot Screw, for Styles 16-260, -265-----	1
3	1005 L	Set Screw, for Styles 16-100, -100 H, -290, -400, -410 B, -410 T, -420-----	1
	1003 L	Set Screw, for Styles 16-260, -265-----	1
4	14-323	Main Shaft-----	1
5	57-45	Handwheel, 3 7/32 inch working diameter-----	1
6	57-42	Handwheel, on new machines, 4 11/16 inch working diameter-----	1
7	CS320-1/2	Set Screw-----	2
8	18-748	Screw-----	1
9	40-180	Washer-----	1
10	1206 L	Clamp Screw-----	1
11	1218 L	Plunger Connecting Rod-----	1
12	1209 AL	Feed Driving and Plunger Crank Disc, complete-----	1
13	1214 L	Spring-----	2
14	1213 L	Screw-----	1
15	1020 L	Spot Screw-----	1
16	1210 L	Spot Screw-----	1
17	1207 L	Feed Driving and Plunger Crank Disc-----	1
18	1211 L	Set Screw-----	1
19	1208 L	Guide Pin-----	1
20	1212 L	Feed Driving Eccentric-----	1
21	1206 L	Clamp Screw-----	2
22	1205 L	Feed Driving Connecting Rod-----	1
23	1215 L	Feed Elevating Connecting Rod-----	1
24	1204 L	Feed Elevating Eccentric-----	1
25	1147 L	Spot Screw-----	1
26	1005 L	Set Screw-----	1
27	1009 L	Nut-----	5
28	448-75	Feed Driving and Elevating Crank-----	2
29	1243 L	Clamp Screw-----	1
30	1244 L	Bearing Screw-----	3
31	1288 L	Bearing Screw-----	2
32	1291 L	Plunger Differential Crank-----	1
33	1292 L	Plunger Differential Crank Link-----	1
34	1293 L	Plunger Rocker Crank-----	1
35	1333 L	Set Screw-----	1
36	1294 L	Spot Screw-----	1
37	1027 L	Collar-----	1
38	1029 L	Set Screw-----	2
39	1055 L	Spring Pin-----	1
40	1283 L	Spring-----	1
41	1284 L	Collar-----	2
42	1022 L	Set Screw-----	1
43	478-11	Ball Bearing, complete with washers-----	1
44	449-32	Feed Depresser Yoke, complete with pin-----	1
	449-33	Feed Depresser Yoke, complete with pin, on new machines-----	1
45	1281 L	Spring Pin-----	1
46	1272 L	Nut-----	1
47	21-26	Flat Feed Spring, short, for Style 16-400-----	1
48	1270 L	Flat Feed Spring, long, for Styles 16-100, -100 H, -260, -265, -290, -400, -410 B, -410 T-----	1
	1270 L	Flat Feed Spring, long, for Style 16-420-----	2
49	1271 L	Knurled Adjusting Screw-----	1
50	478-23	Ball Bearing, complete with washers-----	1
51	16-366	Plunger Rocker Shaft Bushing-----	1
52	1295 L	Plunger Rocker Shaft-----	1
53	61-82	Plunger Rocker Shaft Tube-----	1

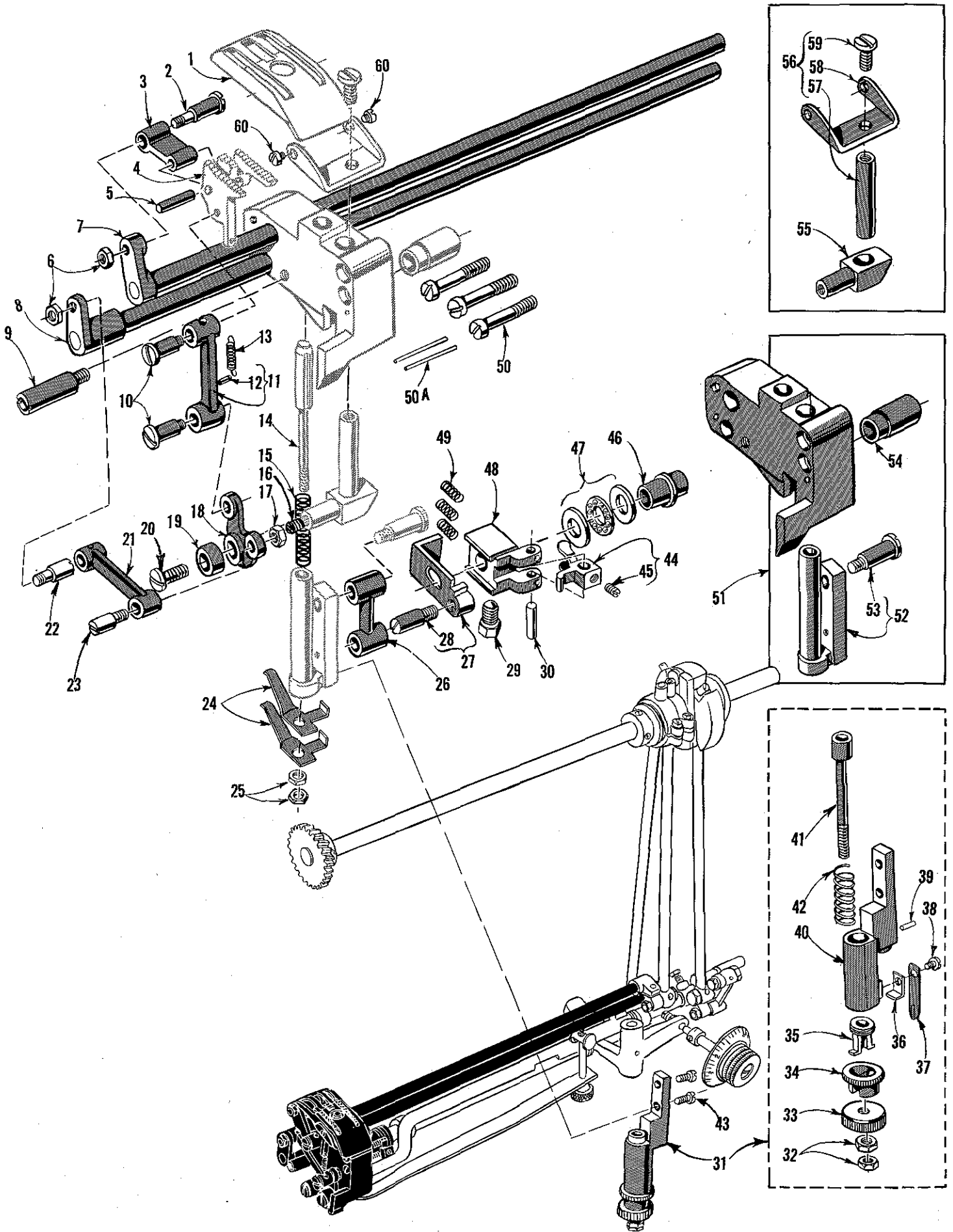

FEED AND PLUNGER DRIVING PARTS

<u>Ref. No.</u>	<u>Part No.</u>	<u>Description</u>	<u>Amt. Req.</u>
1		Feed Plate - See Page Nos. 31, 33, 35, 37, 39 -----	1
2	1260 L	Bearing Screw -----	1
3	1261 L	Feed Link -----	1
4		Feed Point - See Page Nos. 31, 33, 35, 37, 39-----	1
5	1262 L	Hinge Pin -----	1
6	1160 L	Nut -----	2
7	1259 AL	Feed Rocker Shaft, complete with crank -----	1
8	1248 AL	Feed Elevating Rocker Shaft, complete with crank -----	1
9	1667 L	Stud -----	1
10	1671 L	Bearing Screw -----	2
11	1677 AL	Feed Link, complete -----	1
12	1254 L	Spring Pin -----	1
13	1256 L	Feed Retaining Spring -----	1
14		Plunger - See Page Nos. 31, 33, 35, 37, 39 -----	1
15	1309 L	Plunger Spring, heavy, for Styles 16-100, -100 H, -420-----	1
	1584 L	Plunger Spring, medium, for Styles 16-290, -400, -410 B -----	1
	1310 L	Plunger Spring, light, for Styles 16-260, -265, -410 T -----	1
16	18-533	Screw, for slide block -----	1
17	1160 L	Nut -----	1
18	1669 L	Feed Elevating Bell Crank -----	1
19	1672 L	Roll -----	1
20	18-745	Bearing Screw -----	1
21	46-94	Feed Elevating Link -----	1
22	1249 L	Bearing Stud -----	1
23	1249 L	Bearing Screw -----	1
24	21-255	Plunger Equalizing Spring, for Styles 16-100, -420 -----	2
25	1311 L	Nut -----	2
26	1304 L	Plunger Frame Link -----	1
27	48-168	Plunger Crank -----	1
28	18-1027	Bearing Screw -----	1
29	1298 L	Spot Screw -----	1
30	22-297	Pin -----	1
31	426-93	Automatic Plunger, complete, for Styles 16-410 B, -410 T-----	1
	426-93-1	Automatic Plunger, complete, for Styles 16-100 H, -400 -----	1
32	1311 L	Nut -----	2
33	20-98	Knurled Adjusting Nut -----	1
34	149-22	Regulator -----	1
35	70-33	Pressure Adjusting Sleeve -----	1
36	42-14	Regulator Stop -----	1
37	21-19	Retaining Spring -----	1
38	18-125	Screw -----	1
39	22-9	Guide Pin -----	1
40	50-138	Bracket -----	1
41	26-93	Plunger, lower -----	1
42	21-230	Pressure Spring, for Styles 16-410 B, -410 T-----	1
	21-281	Pressure Spring, for Styles 16-100 H, -400 -----	1
43	18-791	Screw, for Styles 16-100 H, -400, -410 B, -410 T-----	2
44	48-165	Plunger Regulating Bell Crank, small -----	1
45	18-416	Set Screw -----	1
46	16-366	Plunger Regulating Crank Shaft Bushing -----	1
47	478-23	Ball Bearing, complete -----	1
48	115-139	Plunger Regulating Block -----	1
49	21-403	Plunger Crank Spring -----	3
50	1279 L	Screw -----	3
50A	667 B-20	Dowel Pin, on new machines -----	2
51	4115-72-4	Plunger Bearing Block, complete, for Styles 16-100, -100 H, -400, -410 B, -410 T, -420 -----	1
	4115-73-3	Plunger Bearing Block, complete, for Styles 16-260, -265, -290 -----	1
52	4121-3	Plunger Frame and Barrel Assembly, for Styles 16-100, -100 H, -400, -410 B, -410 T, -420 -----	1
	470-31	Plunger Frame and Barrel Assembly, for Styles 16-260, -265, -290 -----	1
53	1306 L	Screw -----	1
54	16-352	Bushing -----	1
55	1273 L	Slide Block -----	1
56	1417 AL	Feed Plate Yoke, complete -----	1
57	1413 L	Feed Plate Stem -----	1
58	1415 L	Feed Plate Yoke -----	1
59	FP539	Screw -----	1
60	1414 L	Screw -----	2

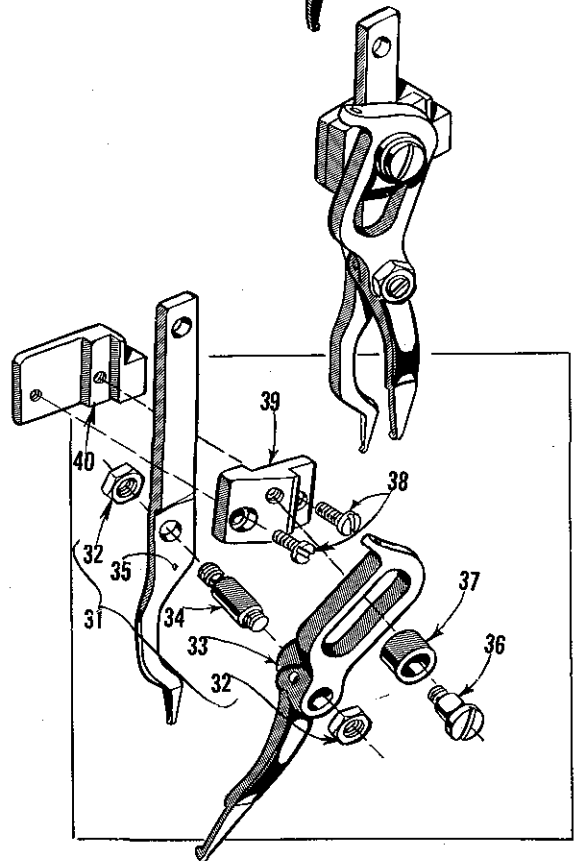
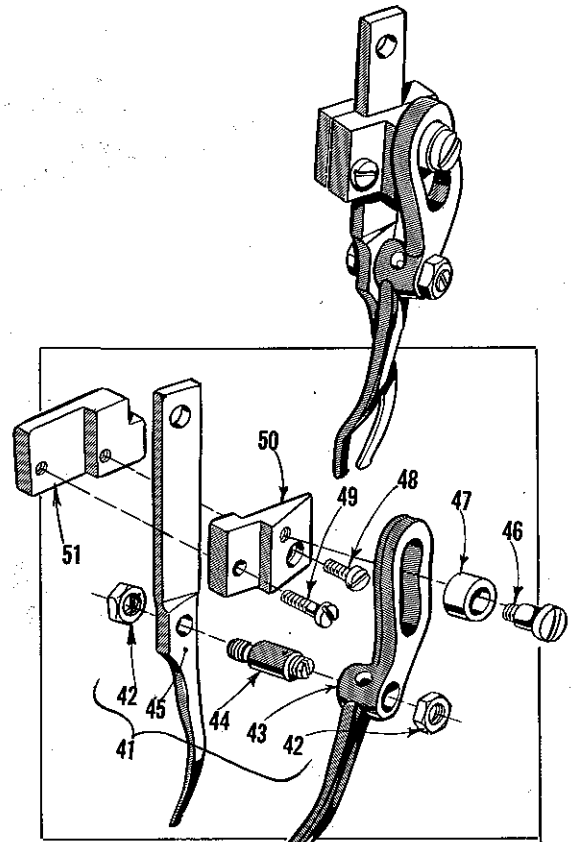
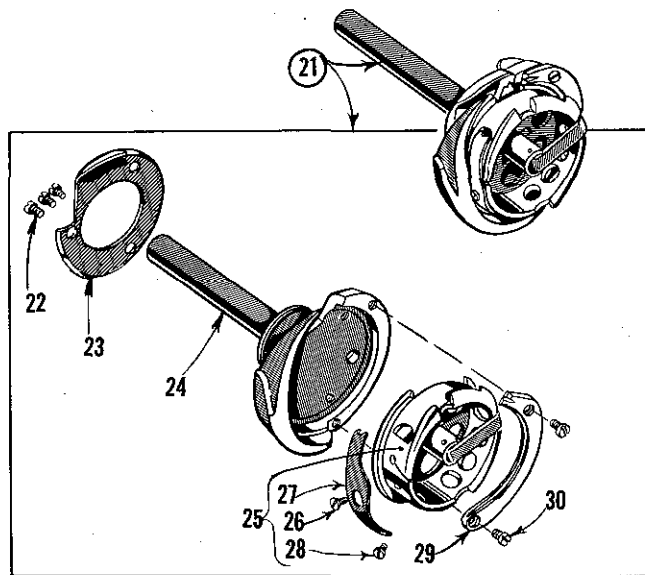
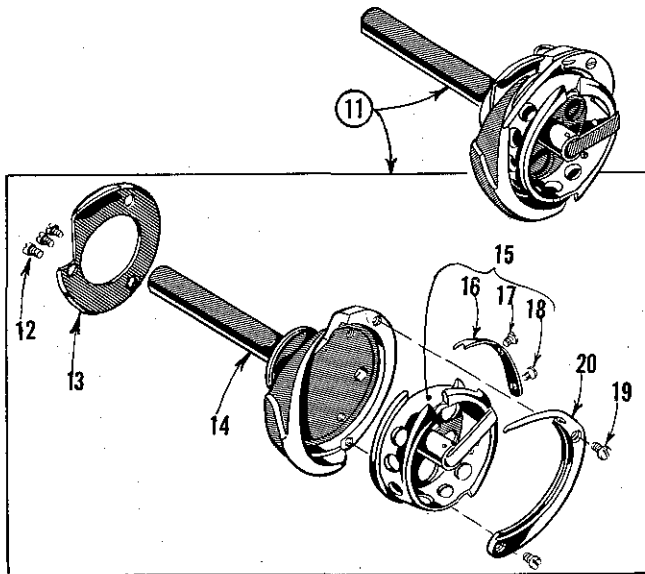
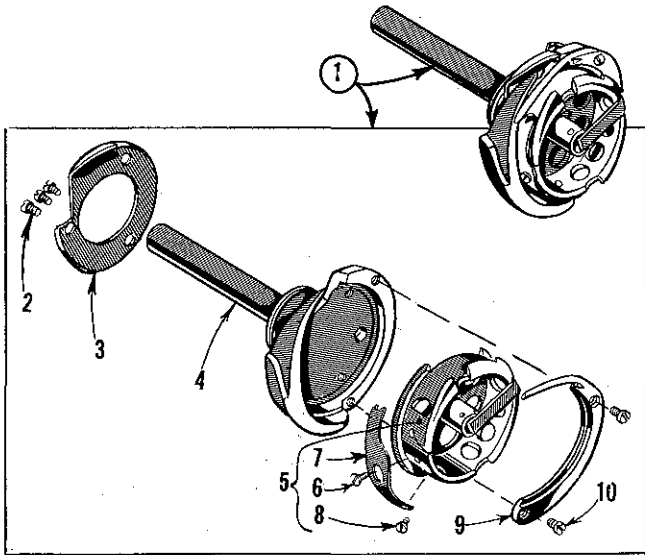

ROTARY HOOKS, LOOPER AND SPREADER ASSEMBLIES

<u>Ref. No.</u>	<u>Part. No.</u>	<u>Description</u>	<u>Amt. Req.</u>
1	1040 A-1 L	Hook, complete with bobbin case, for Styles 16-100, -100 H, -290, -400, -410 B, -410 T-----	1
2	1036 L	Screw-----	3
3	1035 L	Needle and Thread Guard-----	1
4	1034 AL	Hook-----	1
5	1041 AL	Bobbin Case-----	1
6	1046 L	Tension Screw-----	1
7	1043 L	Tension Spring-----	1
8	18-912	Clamp Screw-----	1
9	1037 L	Hook Gib-----	1
10	1039 L	Screw-----	2
11	1040 A-2 L	Hook, complete with bobbin case, for Styles 16-260, -265,-----	1
12	1036 L	Screw-----	3
13	1035 L	Needle and Thread Guard-----	1
14	1034 AL	Hook-----	1
15	411-6	Bobbin Case-----	1
16	21-245	Tension Spring-----	1
17	1046 L	Tension Screw-----	1
18	18-912	Clamp Screw-----	1
19	1039 L	Screw-----	2
20	1037 L	Hook Gib-----	1
21	409-25-1	Hook, complete with bobbin case, for Style 16-420-----	1
22	1036 L	Screw-----	3
23	1035 L	Needle and Thread Guard-----	1
24	1034 AL	Hook-----	1
25	411-5	Bobbin Case-----	1
26	1046 L	Tension Screw-----	1
27	1043 L	Tension Spring-----	1
28	18-912	Clamp Screw-----	1
29	13-22	Hook Gib-----	1
30	1039 L	Screw-----	2
31	437-4	Looper and Spreader, complete, for Styles 16-100, -100 H, -290, -400, -410 B, -410 T, -420-----	1
32	1160 L	Nut-----	2
33	37-4	Looper Spreader-----	1
34	17-104	Stud-----	1
35	36-14	Looper-----	1
36	1180 L	Screw-----	1
37	1179 L	Roll-----	1
38	1170 L	Screw, for Styles 16-100, -100 H, -290, -400, -410 B, -410 T, -420-----	2
39	1166 L	Looper Staff Bearing Cap, for Styles 16-100, -100 H, -290, -400, -410 B, -410 T, -420-----	1
<i>check</i> 40	117-49 ⁵²	Looper Staff Bearing, for Styles 16-100, -100 H, -290, -400, -410 B, -410 T, -420-----	1
41	437-2	Looper and Spreader, complete, for Styles 16-260, -265-----	1
42	1160 L	Nut-----	2
43	37-2	Looper Spreader-----	1
44	17-104	Stud-----	1
45	36-12	Looper-----	1
46	1180 L	Screw-----	1
47	1179 L	Roll-----	1
48	1170 L	Screw, for Styles 16-260, -265-----	1
49	916 L	Screw, for Styles 16-260, -265-----	1
50	125-21	Looper Staff Bearing Cap for Styles 16-260, -265-----	1
51	117-53	Looper Staff Bearing for Styles 16-260, -265-----	1

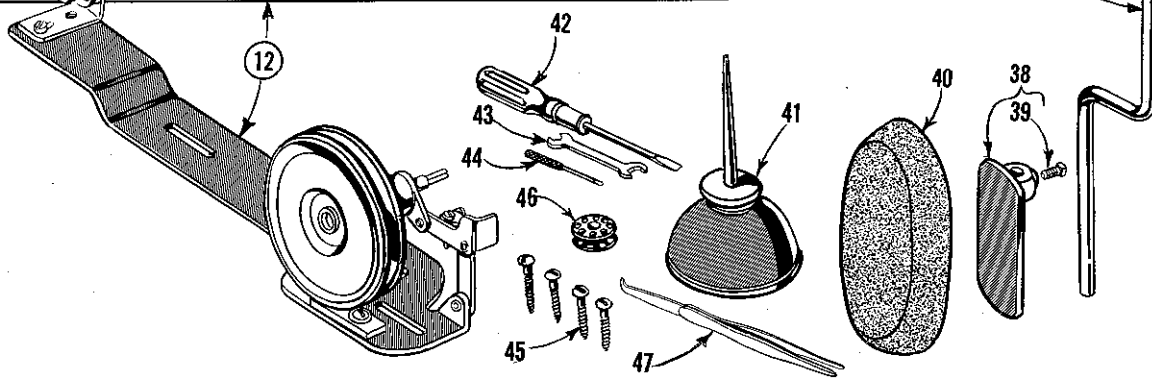
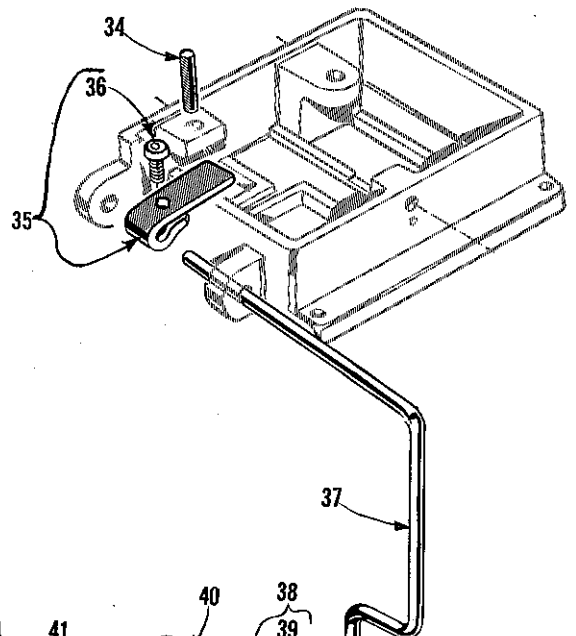
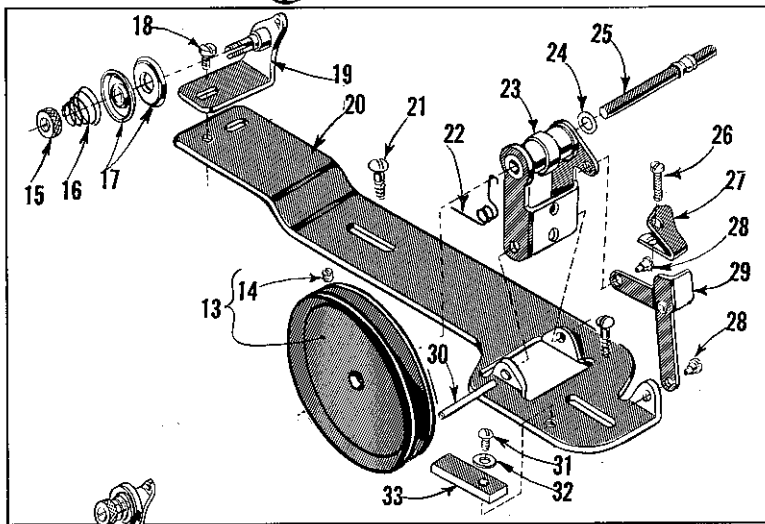
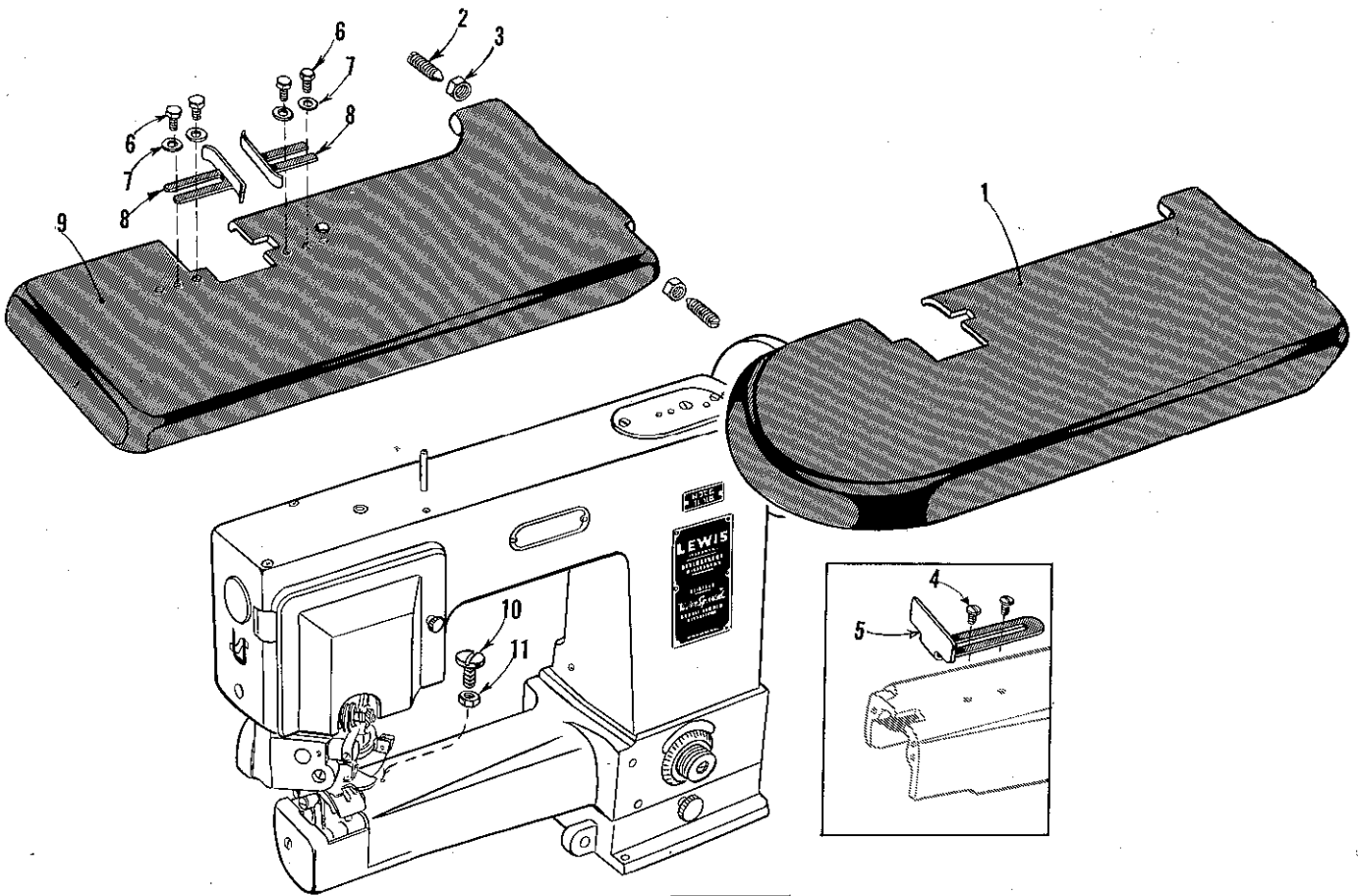

WORK SUPPORT PLATES AND ACCESSORIES

<u>Ref. No.</u>	<u>Part No.</u>	<u>Description</u>	<u>Amt. Req.</u>
1	4-136	Work Support Plate, for Styles 16-100 H, -400, -410 B, -410 T-----	1
2	LS398	Pivot Screw, for Styles 16-100 H, -400, -410 B, -410 T, -420-----	2
3	LS299	Nut, for Styles 16-100 H, -400, -410 B, -410 T, -420--	2
4	18-330	Screw, for Style 16-290-----	2
5	75-133	Edge Guide, for Style 16-290-----	1
6	18-970	Screw, for Style 16-420-----	4
7	40-38	Washer, for Style 16-420-----	4
8	75-244	Edge Guide, for Style 16-420-----	2
9	4-138	Work Support Plate, for Style 16-420-----	1
10	FP505	Adjusting Screw, for Styles 16-100 H, -400, -410 B, -410 T, -420-----	1
11	1160 L	Nut, for Styles 16-100 H, -400, -410 B, -410 T, -420--	1
12	61477	Bobbin Winder, complete-----	1
13	61377 Y	Pulley-----	1
14	22878	Set Screw-----	1
15	61292 C	Tension Nut-----	1
16	61392 F-14	Tension Spring-----	1
17	109	Tension Disc-----	2
18	22875	Screw-----	1
19	61477 C	Tension Post Bracket-----	1
20	61377 A	Base-----	1
21	22846 M-12	Wood Screw-----	2
22	61477 E	Release Spring-----	1
23	61477 A	Frame Assembly-----	1
24	6042 A	Thrust Washer-----	1
25	61377 J	Pulley Shaft-----	1
26	22729 A	Screw-----	1
27	61377 N	Trip Latch-----	1
28	22760 A	Screw-----	2
29	61477 B	Trip Latch Assembly-----	1
30	61477 D	Hinge Pin-----	1
31	22635 B-20	Screw-----	1
32	69 H	Washer-----	1
33	61377 W	Pulley Brake, leather-----	1
34	22-301	Feed Plate Lowering Pin-----	1
35	45-422	Lever-----	1
36	22652 F-12	Clamp Screw-----	1
37	71-86	Knee Press Rod-----	1
38	4129-18	Knee Press Plate, complete-----	1
39	22508	Screw-----	1
*40	660-168	Knee Press Pad-----	1
41	413	Oil Can-----	1
42	21201	Screwdriver, large-----	1
43	1405 L	Double End Wrench-----	1
44	21207	Screwdriver, small-----	1
45	1500 L	Wood Screw-----	4
46	1047 L	Bobbin-----	1
47	660-240	Thread Tweezers-----	1

* Not furnished with machine, available as extra send and charge item.

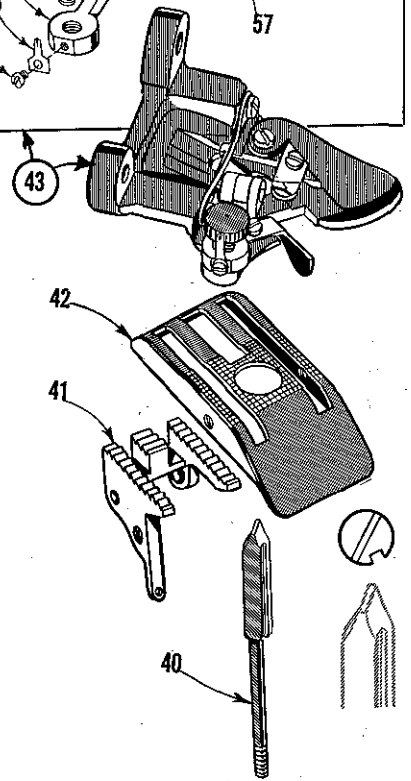
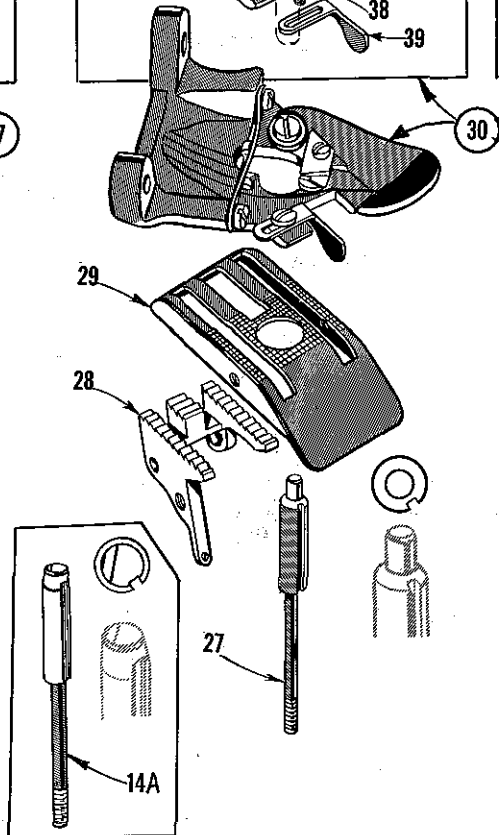
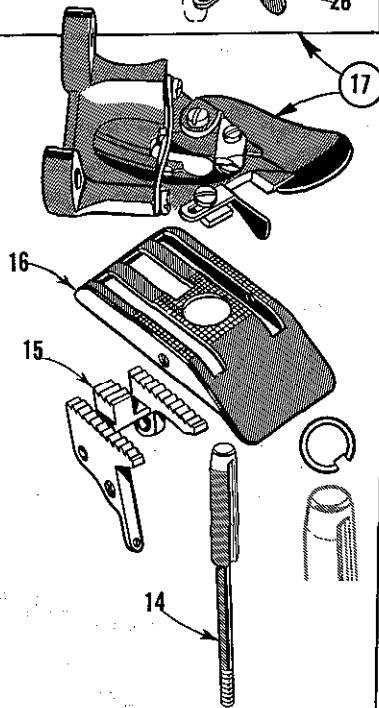
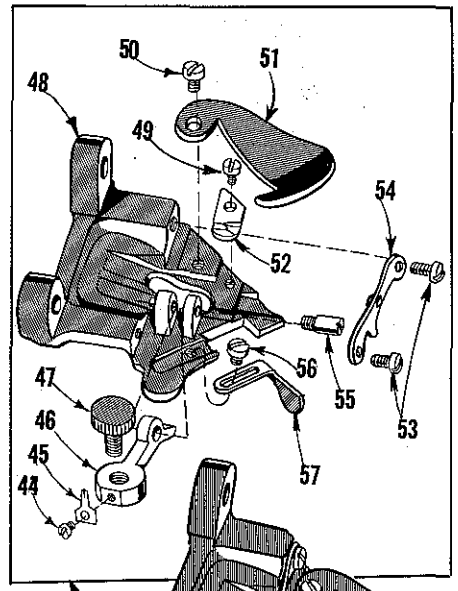
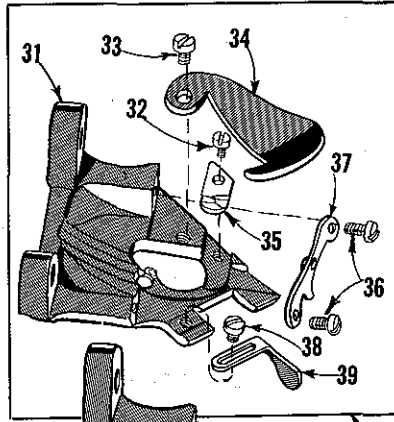
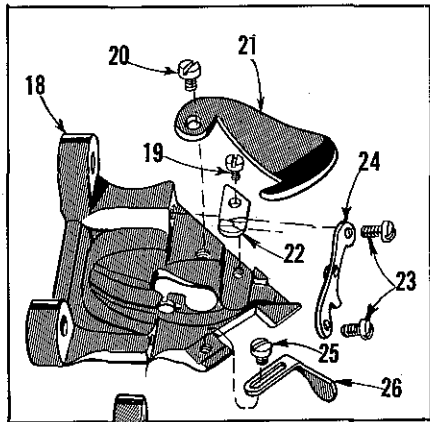
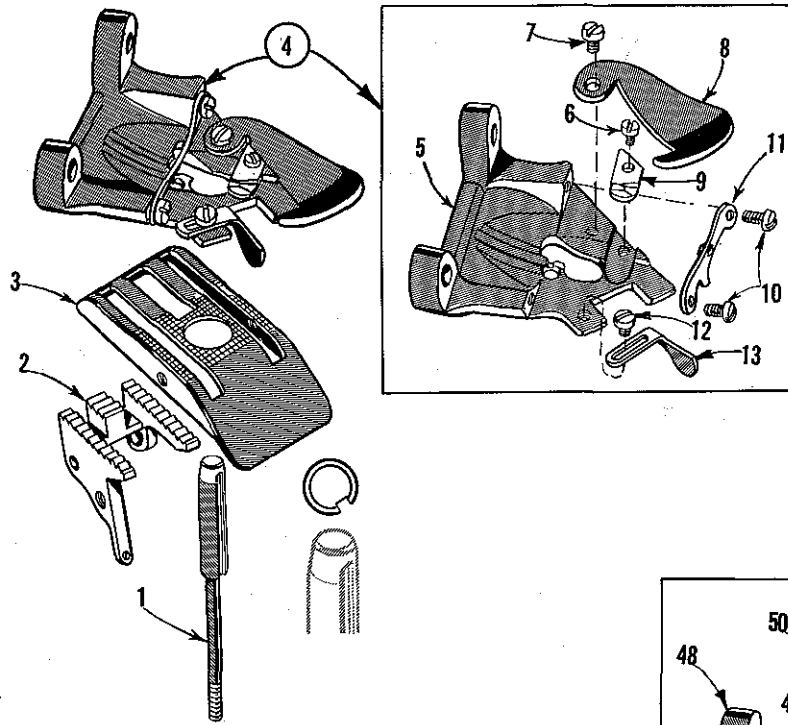

PRESSER FEET, FEED PLATES, FEED POINTS, PLUNGERS

<u>Ref. No.</u>	<u>Part No.</u>	<u>Description</u>	<u>Amt. Req.</u>
Standard Combination for Style 16-100 for Medium Weight Material			
1	1353 L	Plunger -----	1
2	23-322	Feed Point-----	1
3	24-285	Feed Plate-----	1
4	1340 AL	Presser Foot, complete-----	1
5	1340 L	Presser Foot, main section -----	1
6	1075 L	Screw -----	1
7	18-281	Screw -----	1
8	1346 L	Needle Guard -----	1
9	1348 L-1/4	Needle Guide-----	1
10	1058 L	Screw -----	2
11	1057 L	Bobbin Case Retainer-----	1
12	1351 L	Screw -----	1
13	1349 L	Edge Guide -----	1
Alternate Combination for Style 16-100 for Light Weight Material			
14	1353 L	Plunger -----	1
*14A	26-139	Plunger -----	1
15	23-322	Feed Point-----	1
16	24-285	Feed Plate-----	1
17	1340 SAL	Presser Foot, complete-----	1
18	1340 SL	Presser Foot, main section -----	1
19	1075 L	Screw -----	1
20	18-281	Screw -----	1
21	1346 L	Needle Guard -----	1
22	1348 L-1/4	Needle Guide-----	1
23	1058 L	Screw -----	2
24	1057 L	Bobbin Case Retainer-----	1
25	1351 L	Screw -----	1
26	1349 L	Edge Guide -----	1
Alternate Combination for Style 16-100 for Heavy Weight Material			
27	1352 L	Plunger -----	1
28	23-322	Feed Point-----	1
29	24-285	Feed Plate-----	1
30	1339 SAL	Presser Foot, complete-----	1
31	1339 SL	Presser Foot, main section -----	1
32	1075 L	Screw -----	1
33	18-281	Screw -----	1
34	1346 L	Needle Guard -----	1
35	1348 L-1/4	Needle Guide-----	1
36	1058 L	Screw -----	2
37	1057 L	Bobbin Case Retainer-----	1
38	1351 L	Screw -----	1
39	1349 L	Edge Guide -----	1
Alternate Combination for Style 16-100 for Light Weight Material with Crown Presser Foot			
40	26-121	Plunger -----	1
41	23-322	Feed Point-----	1
42	24-285	Feed Plate-----	1
43	1490 AL	Presser Foot, complete-----	1
44	1036 L	Screw -----	1
45	1778 L	Retaining Spring-----	1
46	1491 L	Crown-----	1
47	1493 L	Adjusting Screw -----	1
48	1490 L	Presser Foot, main section -----	1
49	1075 L	Screw -----	1
50	18-281	Screw -----	1
51	1346 L	Needle Guard -----	1
52	1348 L-1/4	Needle Guide-----	1
53	1058 L	Screw -----	2
54	1057 L	Bobbin Case Retainer-----	1
55	1492 L	Crown Bearing Screw -----	1
56	1351 L	Screw -----	1
57	1349 L	Edge Guide -----	1

* Alternate Combination for Sewing Fine Material on a Raw Edge.

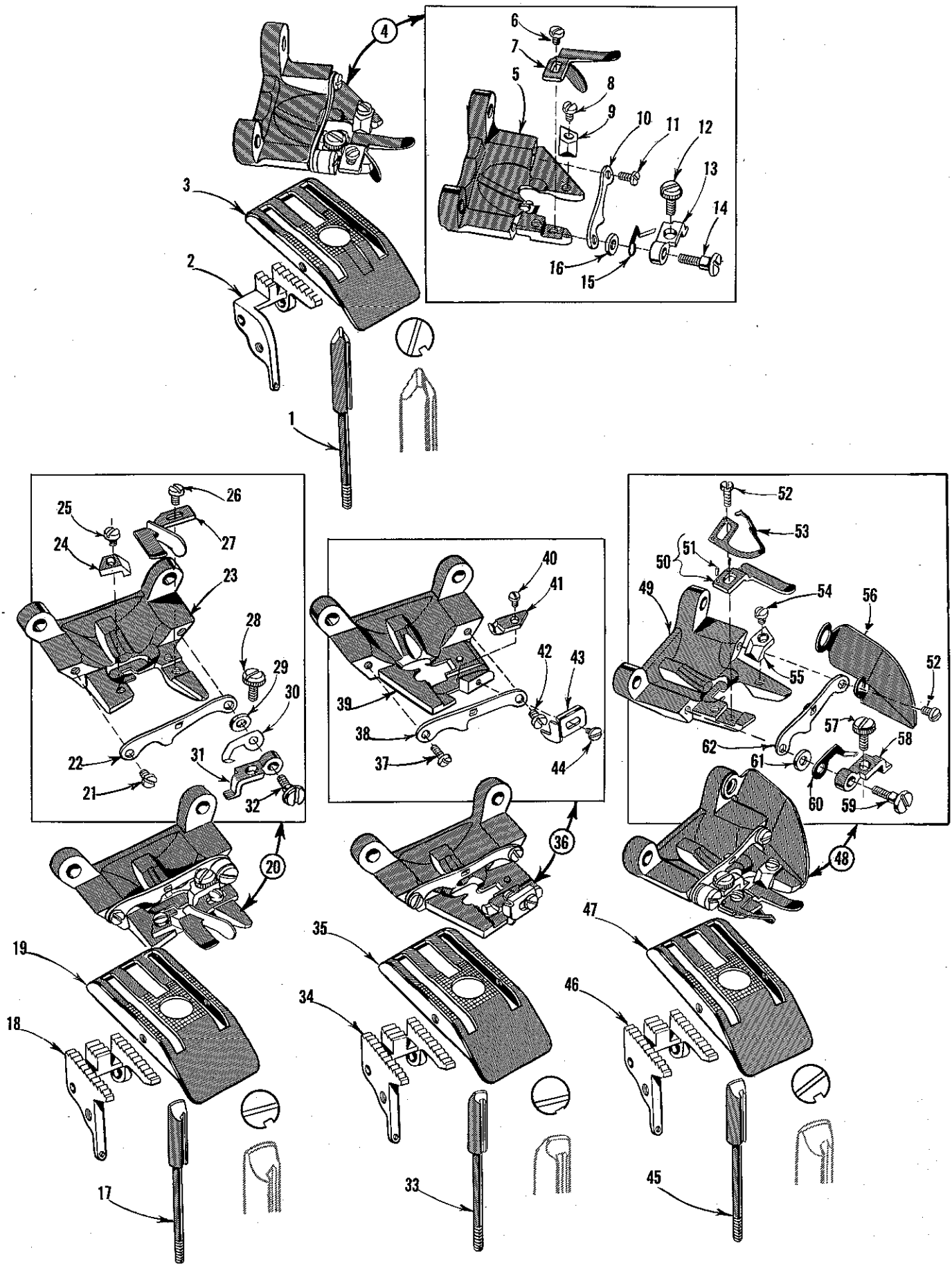

PRESSER FEET, FEED PLATES, FEED POINTS, PLUNGERS

<u>Ref. No.</u>	<u>Part No.</u>	<u>Description</u>	<u>Amt. Req.</u>
Standard Combination for Style 16-100 H for Heavy Weight Material with Crown Presser Foot			
1	26-182	Plunger -----	1
2	23-328	Feed Point -----	1
3	24-315	Feed Plate -----	1
4	405-322	Presser Foot, complete -----	1
5	5-322	Presser Foot, main section -----	1
6	18-281	Screw -----	1
7	406-35	Needle Guide, complete -----	1
8	1351 L	Screw -----	1
9	115-48	Needle Guide Support Block -----	1
10	1057 L	Bobbin Case Retainer -----	1
11	1058 L	Screw -----	1
12	18-985	Adjusting Screw -----	1
13	126-51	Crown -----	1
14	1655 L	Crown Bearing Screw -----	1
15	1654 L	Retaining Spring -----	1
16	1656 L	Washer -----	1
Standard Combination for Style 16-260 for Light and Medium Weight Material with Crown Presser Foot			
17	26-72	Plunger -----	1
18	23-322	Feed Point -----	1
†	23-285	Feed Point -----	1
19	24-285	Feed Plate -----	1
20	405-320	Presser Foot, complete -----	1
21	1058 L	Screw -----	1
22	1057 L	Bobbin Case Retainer -----	1
23	5-320	Presser Foot, main section -----	1
24	115-48	Needle Guide Support Block -----	1
25	1058 L	Screw -----	1
26	1058 L	Screw -----	1
27	406-59	Needle Guide, complete -----	1
28	18-985	Adjusting Screw -----	1
29	1656 L	Washer -----	1
30	21-214	Retaining Spring -----	1
31	126-24	Crown -----	1
32	1655 L	Crown Bearing Screw -----	1
Standard Combination for Style 16-265 for Heavy Weight Material			
33	26-129	Plunger -----	1
34	23-285	Feed Point -----	1
35	24-285	Feed Plate -----	1
36	405-408	Presser Foot, complete -----	1
37	1058 L	Screw -----	1
38	1057 L	Bobbin Case Retainer -----	1
39	5-408	Presser Foot, main section -----	1
40	1075 L	Screw -----	1
41	6-37	Needle Guide -----	1
42	1058 L	Screw -----	1
43	75-179	Edge Guide -----	1
44	18-292	Screw -----	1
Standard Combination for Style 16-290 for Light and Medium Weight Material with Crown Presser Foot			
45	26-75	Plunger -----	1
46	23-324	Feed Point -----	1
47	24-285	Feed Plate -----	1
48	405-321	Presser Foot, complete -----	1
49	5-321	Presser Foot, main section -----	1
50	406-57	Needle Guide, complete -----	1
51	1374 L	Pin -----	2
52	1058 L	Screw -----	2
53	75-130	Edge Guide -----	1
54	1351 L	Screw -----	1
55	115-48	Needle Guide Support Block -----	1
56	8-87	Guard -----	1
57	18-985	Adjusting Screw -----	1
58	1652 L	Crown -----	1
59	1655 L	Crown Bearing Screw -----	1
60	1654 L	Retaining Spring -----	1
61	1656 L	Washer -----	1
62	1057 L	Bobbin Case Retainer -----	1

† Alternate Combination for Heavy Weight Work.

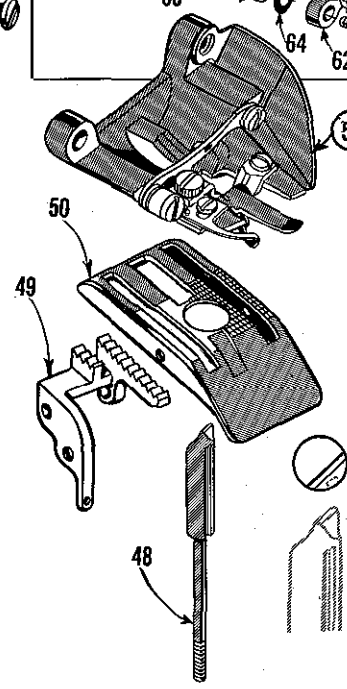
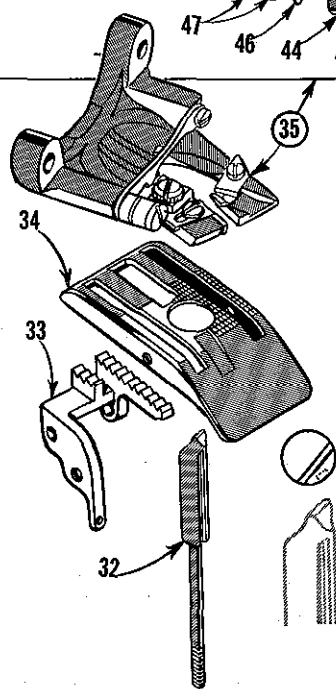
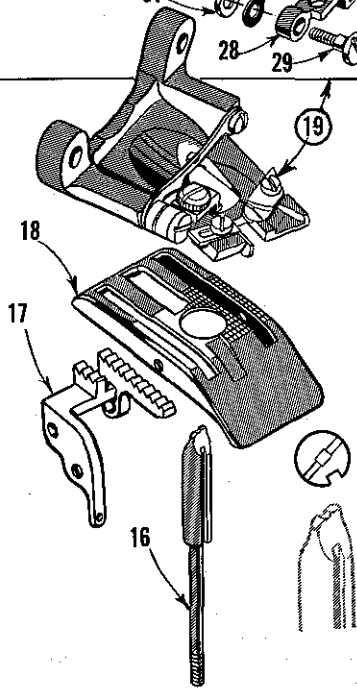
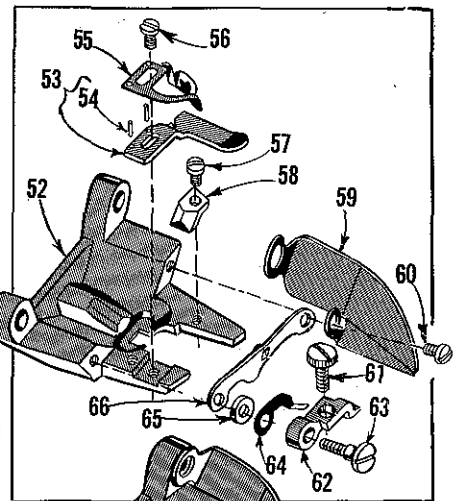
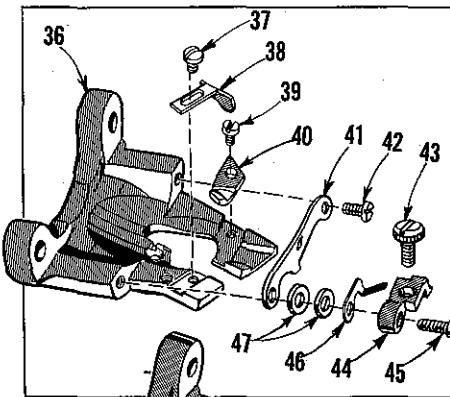
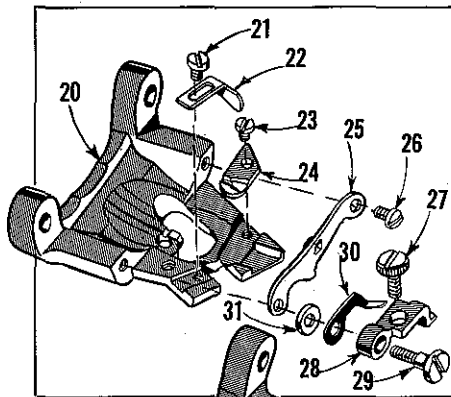
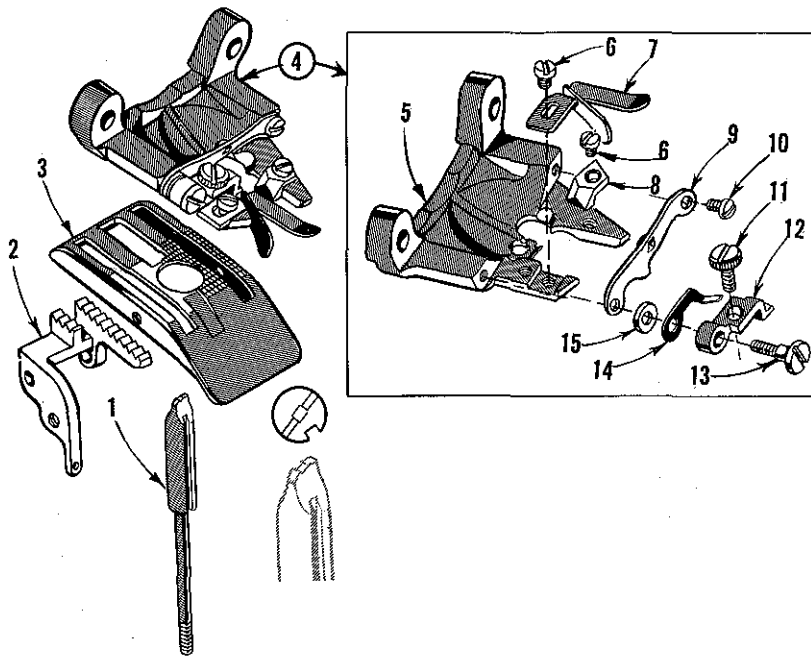

PRESSER FEET, FEED PLATES, FEED POINTS, PLUNGERS

<u>Ref. No.</u>	<u>Part No.</u>	<u>Description</u>	<u>Amt. Req.</u>
Standard Combination for Style 16-400 for Light Weight Material with Crown Presser Foot			
1	26-136	Plunger-----	1
2	23-326	Feed Point-----	1
3	24-290	Feed Plate-----	1
4	405-197	Presser Foot, complete-----	1
5	5-197	Presser Foot, main section-----	1
6	18-281	Screw-----	2
7	406-69	Needle Guide-----	1
8	115-112	Needle Guide Support Block-----	1
9	1057 L	Bobbin Case Retainer-----	1
10	1058 L	Screw-----	1
11	18-985	Adjusting Screw-----	1
12	126-42	Crown-----	1
13	1655 L	Crown Bearing Screw-----	1
14	1654 L	Spring-----	1
15	1656 L	Washer-----	1
Alternate Combination for Style 16-400 for Medium Weight Material with Crown Presser Foot			
16	26-136	Plunger-----	1
17	23-326	Feed Point-----	1
18	24-290	Feed Plate-----	1
19	405-509	Presser Foot, complete-----	1
20	5-509	Presser Foot, main section-----	1
21	1351 L	Screw-----	1
22	75-216	Edge Guide-----	1
23	1075 L	Screw-----	1
24	1348 L-1/4	Needle Guide-----	1
25	1057 L	Bobbin Case Retainer-----	1
26	1058 L	Screw-----	1
27	18-985	Adjusting Screw-----	1
28	126-42	Crown-----	1
29	1655 L	Crown Bearing Screw-----	1
30	1654 L	Spring-----	1
31	1656 L	Washer-----	1
Alternate Combination for Style 16-400 for Heavy Weight Material with Crown Presser Foot			
32	26-131	Plunger-----	1
33	23-326	Feed Point-----	1
34	24-290	Feed Plate-----	1
35	405-458	Presser Foot, complete-----	1
36	5-458	Presser Foot, main section-----	1
37	1351 L	Screw-----	1
38	75-12	Edge Guide-----	1
39	1075 L	Screw-----	1
40	6-7	Needle Guide-----	1
41	1057 L	Bobbin Case Retainer-----	1
42	1058 L	Screw-----	1
43	18-985	Adjusting Screw-----	1
44	126-42	Crown-----	1
45	1655 L	Crown Bearing Screw-----	1
46	1654 L	Spring-----	1
47	1656 L	Washer-----	2
Alternate Combination for Style 16-400 for Bellows Pockets and Facings with Crown Presser Foot			
48	26-146	Plunger-----	1
49	23-326	Feed Point-----	1
50	24-290	Feed Plate-----	1
51	405-144	Presser Foot, complete-----	1
52	5-144	Presser Foot, main section-----	1
53	406-57	Needle Guide, complete-----	1
54	1374 L	Pin-----	2
55	75-131	Edge Guide-----	1
56	1058 L	Screw-----	1
57	1351 L	Screw-----	1
58	115-48	Needle Guide Support Block-----	1
59	8-87	Guard-----	1
60	1058 L	Screw-----	1
61	18-985	Adjusting Screw-----	1
62	1652 L	Crown-----	1
63	1655 L	Crown Bearing Screw-----	1
64	1654 L	Spring-----	1
65	1656 L	Washer-----	1
66	1057 L	Bobbin Case Retainer-----	1

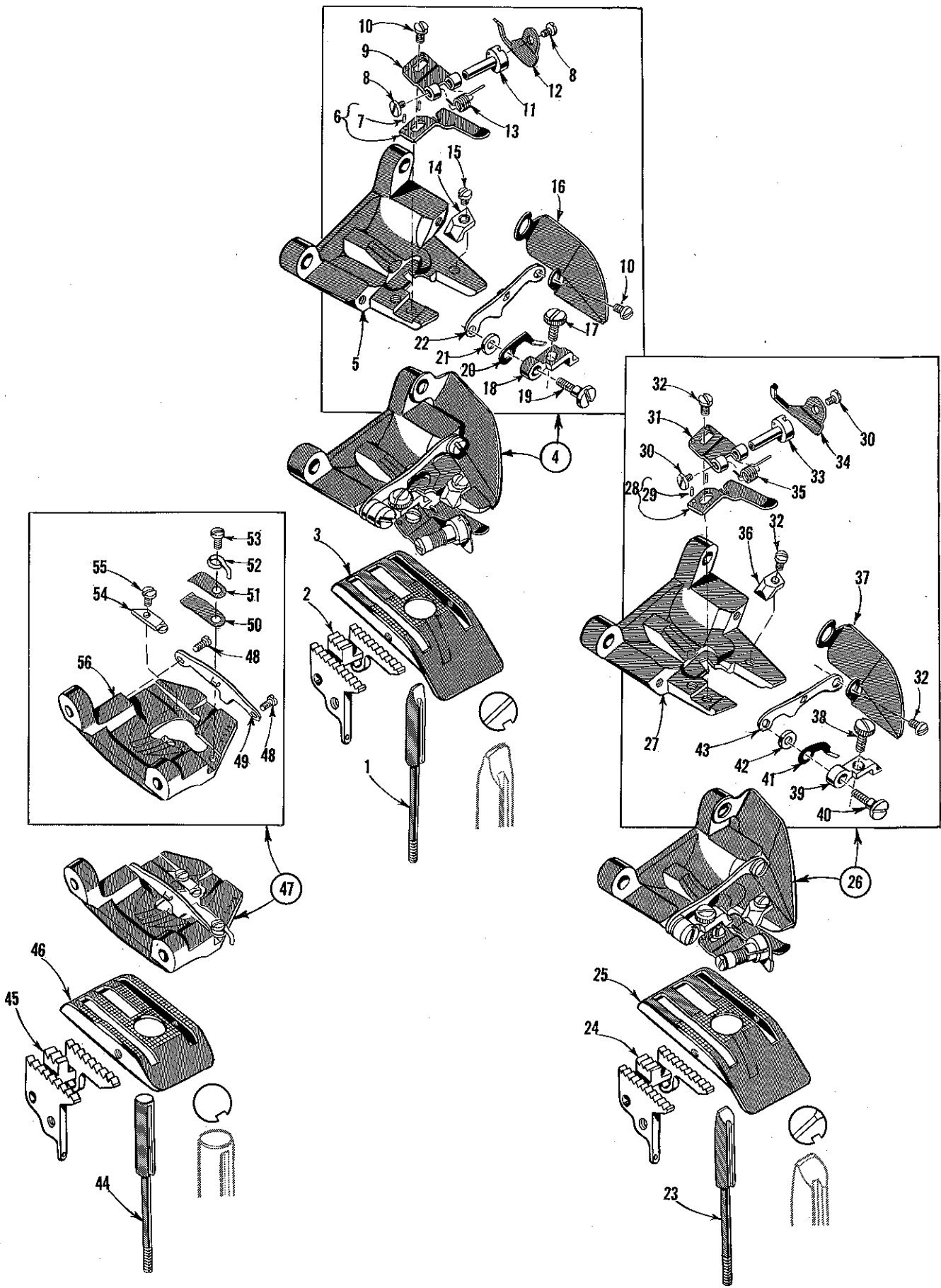

PRESSER FEET, FEED PLATES, FEED POINTS, PLUNGERS

<u>Ref. No</u>	<u>Part No.</u>	<u>Description</u>	<u>Amt. Req.</u>
Standard Combination for Styles 16-410 B for Medium and Heavy Weight Bellows Work with Crown Presser Foot			
1	1359 L	Plunger-----	1
2	23-324	Feed Point-----	1
3	24-312	Feed Plate-----	1
4	405-534	Presser Foot, complete-----	1
5	5-534	Presser Foot, main section-----	1
6	406-64	Needle Guide, complete-----	1
7	1374 L	Pin-----	2
8	18-125	Screw-----	2
9	99-314	Edge Guide Holder-----	1
10	1058 L	Screw-----	2
11	17-156	Edge Guide Stud-----	1
12	75-228	Edge Guide-----	1
13	21-219	Edge Guide Spring-----	1
14	115-48	Needle Guide Support Block-----	1
15	1351 L	Screw-----	1
16	8-87	Guard-----	1
17	18-985	Adjusting Screw-----	1
18	1652 L	Crown-----	1
19	1655 L	Crown Bearing Screw-----	1
20	1654 L	Retaining Spring-----	1
21	1656 L	Washer-----	1
22	1057 L	Bobbin Case Retainer-----	1

Alternate Combination for Style 16-410 B for Light Weight Bellows Work with Crown Presser Foot

23	26-181	Plunger-----	1
24	23-324	Feed Point-----	1
25	24-312	Feed Plate-----	1
26	405-533	Presser Foot, complete-----	1
27	5-533	Presser Foot, main section-----	1
28	406-64	Needle Guide, complete-----	1
29	1374 L	Pin-----	2
30	18-125	Screw-----	2
31	99-314	Edge Guide Holder-----	1
32	1058 L	Screw-----	3
33	17-156	Edge Guide Stud-----	1
34	75-228	Edge Guide-----	1
35	21-219	Edge Guide Spring-----	1
36	115-48	Needle Guide Support Block-----	1
37	8-87	Guard-----	1
38	18-985	Adjusting Screw-----	1
39	1652 L	Crown-----	1
40	1655 L	Crown Bearing Screw-----	1
41	1654 L	Retaining Spring-----	1
42	1656 L	Washer-----	1
43	1057 L	Bobbin Case Retainer-----	1

Standard Combination for Style 16-420 for Printing Press Felt Ink Rolls

44	1354 L	Plunger-----	1
45	23-290	Feed Point-----	1
46	24-288	Feed Plate-----	1
47	405-574	Presser Foot, complete-----	1
48	1058 L	Screw-----	2
49	1057 L	Bobbin Case Retainer-----	1
50	LS404	Cloth Retaining Spring, lower-----	1
51	LS401	Cloth Retaining Spring, upper-----	1
52	75-243	Edge Guide-----	1
53	1351 L	Screw-----	1
54	1348 L	Needle Guide-----	1
55	1075 L	Screw-----	1
56	5-574	Presser Foot, main section-----	1

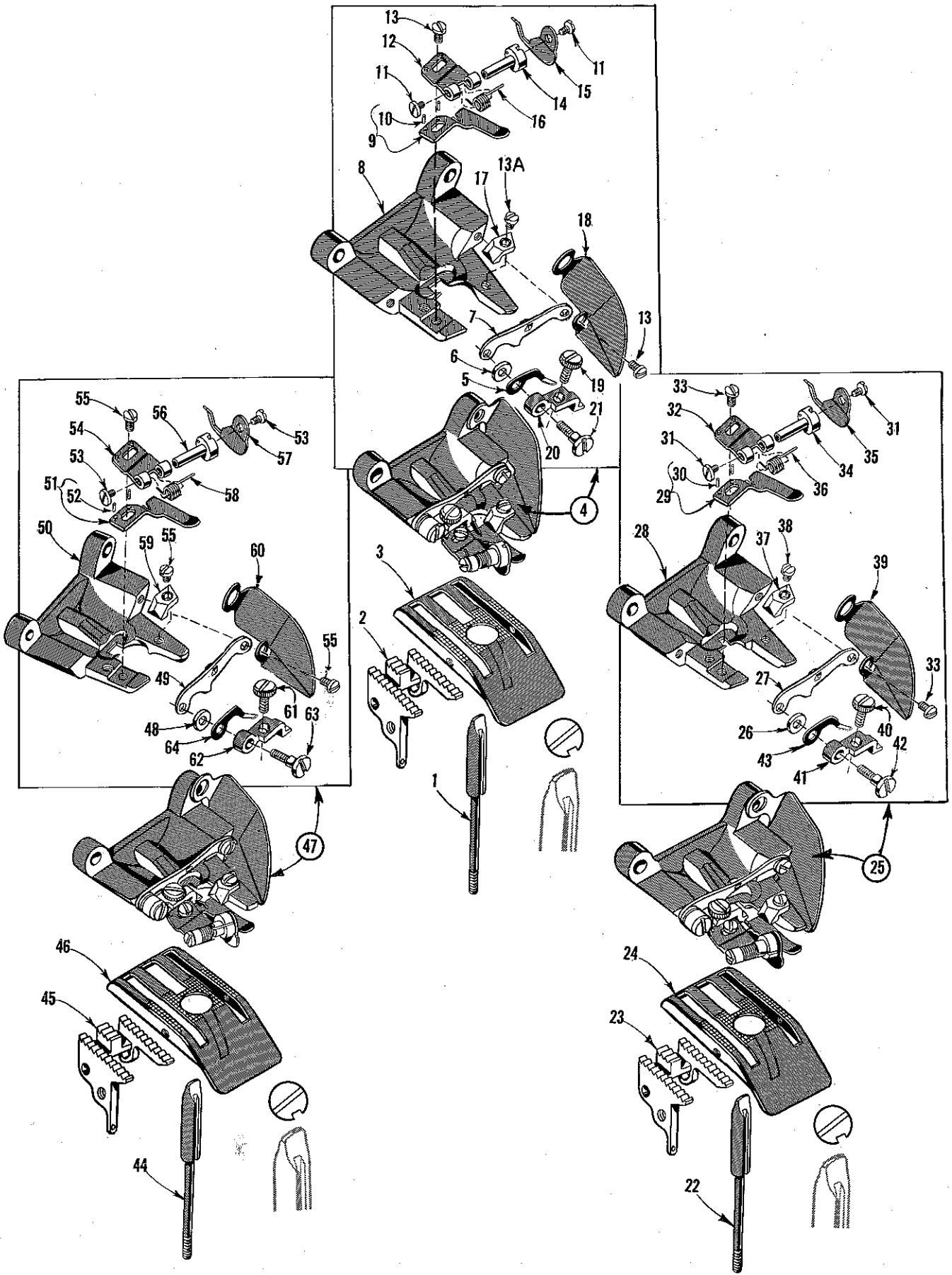

PRESSER FEET, FEED PLATES, FEED POINTS, PLUNGERS

<u>Ref. No.</u>	<u>Part No.</u>	<u>Description</u>	<u>Amt. Req.</u>
Standard Combination for Style 16-410 T for Heavy Weight Work on Bellows and Trouser Curtains with Crown Presser Foot			
1	1359 L	Plunger -----	1
2	23-324	Feed Point-----	1
3	24-312	Feed Plate-----	1
4	405-268-3	Presser Foot, complete-----	1
5	1654 L	Retaining Spring-----	1
6	1656 L	Washer-----	1
7	1057 L	Bobbin Case Retainer-----	1
8	5-268	Presser Foot, main section-----	1
9	406-64	Needle Guide, complete-----	1
10	1374 L	Pin-----	2
11	18-125	Screw-----	2
12	99-314	Edge Guide Holder-----	1
13	1058 L	Screw-----	2
13A	1351 L	Screw-----	1
14	17-156	Edge Guide Stud-----	1
15	75-221	Edge Guide-----	1
16	21-219	Edge Guide Spring-----	1
17	115-48	Needle Guide Support Block-----	1
18	8-87	Guard-----	1
19	18-985	Adjusting Screw-----	1
20	126-50	Crown-----	1
21	1655 L	Crown Bearing Screw-----	1
Alternate Combination for Style 16-410 T for Light, Medium and Heavy Weight Trouser Curtains with Crown Presser Foot			
22	1359 L	Plunger -----	1
23	23-324	Feed Point-----	1
24	24-312	Feed Plate-----	1
25	405-534-1	Presser Foot, complete-----	1
26	1656 L	Washer-----	1
27	1057 L	Bobbin Case Retainer-----	1
28	5-534	Presser Foot, main section-----	1
29	406-64	Needle Guide, complete-----	1
30	1374 L	Pin-----	2
31	18-125	Screw-----	2
32	99-314	Edge Guide Holder-----	1
33	1058 L	Screw-----	2
34	17-156	Edge Guide Stud-----	1
35	75-221	Edge Guide-----	1
36	21-219	Edge Guide Spring-----	1
37	115-48	Needle Guide Support Block-----	1
38	1351 L	Screw-----	1
39	8-87	Guard-----	1
40	18-985	Adjusting Screw-----	1
41	126-50	Crown-----	1
42	1655 L	Crown Bearing Screw-----	1
43	1654 L	Retaining Spring-----	1
Alternate Combination for Style 16-410 T for Light, Medium and Heavy Weight Trouser Curtains where Edge is Folded with Crown Presser Foot			
44	1359 L	Plunger -----	1
45	23-324	Feed Point-----	1
46	24-312	Feed Plate-----	1
47	405-573	Presser Foot, complete-----	1
48	1656 L	Washer-----	1
49	1057 L	Bobbin Case Retainer-----	1
50	5-573	Presser Foot, main section-----	1
51	406-64	Needle Guide, complete-----	1
52	1374 L	Pin-----	2
53	18-125	Screw-----	2
54	99-314	Edge Guide Holder-----	1
55	1058 L	Screw-----	3
56	17-156	Edge Guide Stud-----	1
57	75-221	Edge Guide-----	1
58	21-219	Edge Guide Spring-----	1
59	115-48	Needle Guide Support Block-----	1
60	8-87	Guard-----	1
61	18-985	Adjusting Screw-----	1
62	1652 L	Crown-----	1
63	1655 L	Crown Bearing Screw-----	1
64	1654 L	Retaining Spring-----	1

NUMERICAL INDEX OF PARTS

Part No.	Page No.	Part No.	Page No.	Part No.	Page No.	Part No.	Page No.
3-91.....	17	20-98.....	25	45-422.....	29	405-458.....	35
4-136.....	29	21-19.....	25	46-38.....	19	405-509.....	35
4-138.....	29	21-26.....	23	46-94.....	25	405-533.....	37
5-144.....	35	21-214.....	33	48-165.....	25	405-534.....	37
5-197.....	35	21-219.....	37, 39	48-166.....	17	405-534-1.....	39
5-268.....	39	21-230.....	25	48-168.....	25	405-573.....	39
5-320.....	33	21-237.....	17	50-138.....	25	405-574.....	37
5-321.....	33	21-245.....	27	50-262.....	17	406-35.....	33
5-322.....	33	21-255.....	25	50-263 L.....	17	406-57.....	33, 35
5-408.....	33	21-281.....	25	51-26.....	17	406-59.....	33
5-458.....	35	21-284.....	21	57-42.....	23	406-64.....	37, 39
5-509.....	35	21-403.....	25	57-45.....	23	406-69.....	35
5-533.....	37	21-404.....	17	61-46.....	17		
5-534.....	37, 39	21-410.....	17	61-47.....	17	409-25-1.....	27
5-573.....	39	22-9.....	25	61-49.....	17	411-5.....	27
5-574.....	37	22-148.....	17	61-75.....	17	411-6.....	27
6-7.....	35	22-C214-2 ..	17	61-82.....	23	413.....	29
6-37.....	33	22-C214-4 ..	17	68-19.....	21	416-11.....	19
8-87.....	33, 35, 37,	22-296.....	17	69 H.....	29	418-1026.....	17
	39	22-297.....	25	70-33.....	25	426-93.....	25
13-22.....	27	22-298.....	17	70-70.....	21	426-93-1.....	25
14-307.....	21	22-301.....	29	71-86.....	29	427-131.....	23
14-323.....	23	23-285.....	33	75-12.....	35	430-37-1.....	21
14-472.....	17	23-290.....	37	75-130.....	33	432-136.....	17
14-508.....	17	23-322.....	31, 33	75-131.....	35	432-279.....	17
16-269.....	21	23-324.....	33, 37	75-133.....	29	437-2.....	27
16-352.....	25		39	75-179.....	33	437-4.....	27
16-353.....	17	23-326.....	35	75-216.....	35	445-96.....	19
16-354.....	17	23-328.....	33	75-221.....	39	445-234.....	19
16-356.....	17	24-285.....	31, 33	75-228.....	37	445-251.....	21
16-365.....	21	24-288.....	37	75-243.....	37	448-75.....	23
16-366.....	23, 25	24-290.....	35	75-244.....	29	448-177.....	21
16-367.....	17	24-312.....	37, 39	79-31.....	17	449-32.....	23
16-368.....	17	24-315.....	33	89-58.....	17	449-33.....	23
16-379.....	17	26-72.....	33	99-314.....	37, 39	470-31.....	25
17-104.....	27	26-75.....	33	109.....	29	478-10.....	17
17-156.....	37, 39	26-93.....	25	115-28.....	19	478-11.....	23
17-167.....	17	26-121.....	31	115-48.....	33, 35, 37,	478-13.....	17
17-171.....	21	26-129.....	33		39	478-23.....	23, 25
18-125.....	25, 37, 39	26-131.....	35	115-112.....	35	FP505.....	29
18-281.....	31, 33, 35	26-136.....	35	115-139.....	25	FP539.....	25
18-292.....	33	26-139.....	31	117-49.....	27	660-168.....	29
18-330.....	29	26-146.....	35	117-53.....	27	660-240.....	29
18-416.....	25	26-181.....	37	118-23.....	21	666-65.....	17
18-492.....	23	26-182.....	33	125-21.....	27	667 B-20.....	25
18-533.....	25	27-1.....	19	125-23.....	17, 19	916 L.....	27
18-596.....	17	27-2.....	23	126-24.....	33	1001 L.....	19
18-715.....	21	27-120.....	19	126-42.....	35	1002 L.....	19
18-719.....	21	27-121.....	23	126-50.....	39	1002 L-1/2.....	19
18-745.....	25	28-2.....	19	126-51.....	33	1003 L.....	19, 23
18-748.....	23	32-276.....	17	149-22.....	25	1004 L.....	19
18-791.....	25	32-277.....	17	149-30.....	17	1005 L.....	17, 19, 21,
18-912.....	27	32-281.....	17				23
18-957.....	17	32-282.....	17	CS231.....	17	1006 L.....	19
18-959.....	17	32-285.....	17	LS299.....	29	1006 SL.....	19
18-970.....	29	32-286.....	17	CS313.....	17	1007 L.....	21
18-985.....	33, 35, 37,	36-12.....	27	CS320-1/2.....	23	1008 L.....	21
	39	36-14.....	27	LS330.....	19	1009 L.....	21, 23
18-998.....	17	37-2.....	27	LS398.....	29	1010 L.....	21
18-1027.....	25	37-4.....	27	LS401.....	37	1011 L.....	21
18-1028.....	17	39-128.....	17	LS404.....	37	1012 L.....	21
18-1030.....	17	39-135.....	21	405-144.....	35	1014 L.....	21
18-1045.....	17, 19	40-38.....	29	405-197.....	35		
18-1047.....	17	40-139.....	17	405-268-3.....	39	1016 L.....	21
18-1059.....	21	40-180.....	23	405-320.....	33	1018 AL.....	19
18-1060.....	21	41-28.....	21	405-321.....	33	1019 L.....	19
20-34.....	17	41-55.....	17	405-322.....	33	1020 L.....	19, 23
20-60.....	21	42-14.....	25	405-408.....	33	1021 L.....	19
		44-301.....	17				

NUMERICAL INDEX OF PARTS

Part No.	Page No.	Part No.	Page No.	Part No.	Page No.	Part No.	Page No.
1022 L.....	19, 23	1149 L.....	19	1271 L.....	23	1492 L.....	31
1023 L.....	19	1151 L.....	19	1272 L.....	23	1493 L.....	31
1024 L.....	19	1152 L.....	21	1273 L.....	25	1500 L.....	29
1025 L.....	19	1153 L.....	21	1279 L.....	25	1584 L.....	25
1026 L.....	19	1156 L.....	21	1281 L.....	23	1652 L.....	33, 35, 37, 39
1027 L.....	19, 23	1158 L.....	21	1283 L.....	23	1654 L.....	33, 35, 37, 39
1028 L.....	19	1160 L.....	25, 27, 29	1284 L.....	23	1655 L.....	33, 35, 37, 39
1029 L.....	19, 23	1161 L.....	21	1288 L.....	23	1656 L.....	33, 35, 37, 39
1030 L.....	19	1166 L.....	27	1291 L.....	23	1667 L.....	25
1031 L.....	19	1170 L.....	19, 27	1292 L.....	23	1669 L.....	25
1034 AL.....	27	1173 L.....	17	1293 L.....	23	1671 L.....	25
1035 L.....	27	1179 L.....	27	1294 L.....	23	1672 L.....	25
1036 L.....	21, 27, 31	1180 L.....	27	1295 L.....	23	1677 AL.....	25
1037 L.....	27	1181 L.....	21	1298 L.....	25	1778 L.....	31
1039 L.....	27	1182 AL.....	21	1304 L.....	25	4115-72-4.....	25
1040 A-1 L.....	27	1183 L.....	21	1306 L.....	25	4115-73-3.....	25
1040 A-2 L.....	27	1185 L.....	21	1309 L.....	25	4121-3.....	25
1041 AL.....	27	1186 L.....	21	1310 L.....	25	4129-18.....	29
1043 L.....	27	1187 L.....	21	1311 L.....	25	4149-30.....	17
1046 L.....	27	1188 L.....	21	1321 L.....	17	6042 A.....	29
1047 L.....	21, 29	1189 L.....	21	1333 L.....	23	21201.....	29
1049 L.....	21	1192 L.....	17	1339 SL.....	31	21207.....	29
1053 L.....	21	1200 L.....	23	1339 SAL.....	31	22508.....	29
1054 L.....	21	1201 L.....	23	1340 L.....	31	22635 B-20.....	29
1055 L.....	21, 23	1203 L.....	23	1340 AL.....	31	22652 F-12.....	29
1056 L.....	21	1204 L.....	23	1340 SL.....	31	22729 A.....	29
1057 L.....	31, 33, 35, 37, 39	1205 L.....	23	1340 SAL.....	31	22760 A.....	29
1058 L.....	31, 33, 35, 37, 39	1206 L.....	23	1346 L.....	31	22846 M-12.....	29
1059 L.....	19	1207 L.....	23	1348 L.....	37	22875.....	29
1060 L.....	21	1208 L.....	23	1348 L-1/4.....	31, 35	22878.....	29
1072 L.....	19	1209 AL.....	23	1349 L.....	31	61292 C.....	29
1072 AL.....	19	1210 L.....	23	1351 L.....	31, 33, 35, 37, 39	61377 A.....	29
1073 L.....	19, 21	1211 L.....	23	1352 L.....	31	61377 J.....	29
1074 L.....	19	1212 L.....	23	1353 L.....	31	61377 N.....	29
1075 L.....	19, 31, 33, 35, 37	1213 L.....	23	1354 L.....	37	61377 W.....	29
1080 L.....	19	1214 L.....	23	1359 L.....	37, 39	61377 Y.....	29
1081 L.....	19	1215 L.....	23	1374 L.....	33, 35, 37, 39	61392 F-14.....	29
1136 L.....	21	1218 L.....	23	1405 L.....	29	61477.....	29
1137 L.....	17, 21	1243 L.....	23	1413 L.....	25	61477 A.....	29
1140 L.....	19	1244 L.....	23	1414 L.....	25	61477 B.....	29
1142 L.....	19	1248 AL.....	25	1415 L.....	25	61477 C.....	29
1143 L.....	19	1249 L.....	25	1417 AL.....	25	61477 D.....	29
1144 L.....	19	1254 L.....	25	1420 L.....	21	61477 E.....	29
1146 L.....	19	1256 L.....	25	1432 AL.....	21		
1146 SL.....	19	1259 AL.....	25	1490 L.....	31		
1147 L.....	23	1260 L.....	25	1490 AL.....	31		
		1261 L.....	25	1491 L.....	31		
		1262 L.....	25				
		1270 L.....	23				

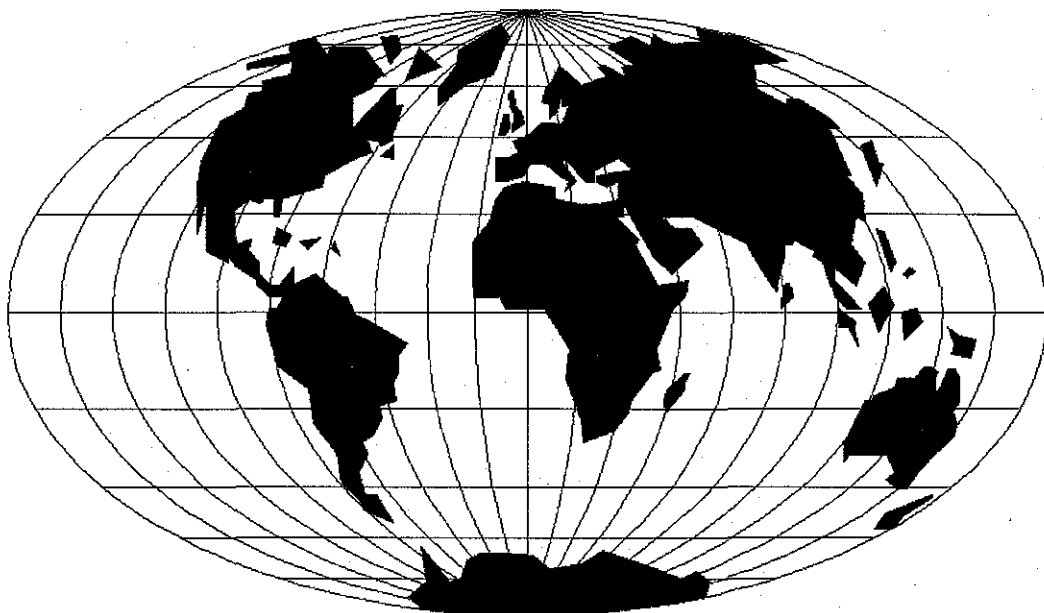

WORLDWIDE SALES AND SERVICE

Union Special Corporation maintains sales and service facilities throughout the world. These offices will aid you in the selection of the right sewing equipment for your particular operation. Union Special Corporation representatives and service technicians are factory trained and are able to serve your needs promptly and efficiently. Whatever your location, there is a qualified representative to serve you.

Corporate Office: One Union Special Plaza
Huntley, IL 60142
Phone: 847•669•5101
Fax: 847•669•4454

European Distribution Center: Union Special GmbH
Raiffeisenstrasse 3
D-71696 Möglingen, Germany
Tel: 49•07141•247•0
Fax: 49•7141•247•100

Brussels, Belgium
Charlotte, N.C.
El Paso, TX
Hong Kong, China
Huntley, IL
Leicester, England
Lille, France
Miami, FL
Milan, Italy
Möglingen, Germany
Montreal, Quebec
Osaka, Japan
Santa Fe Springs, CA

Other Representatives throughout all parts of the world.



Union Special
INDUSTRIAL SEWING EQUIPMENT