

LEWIS

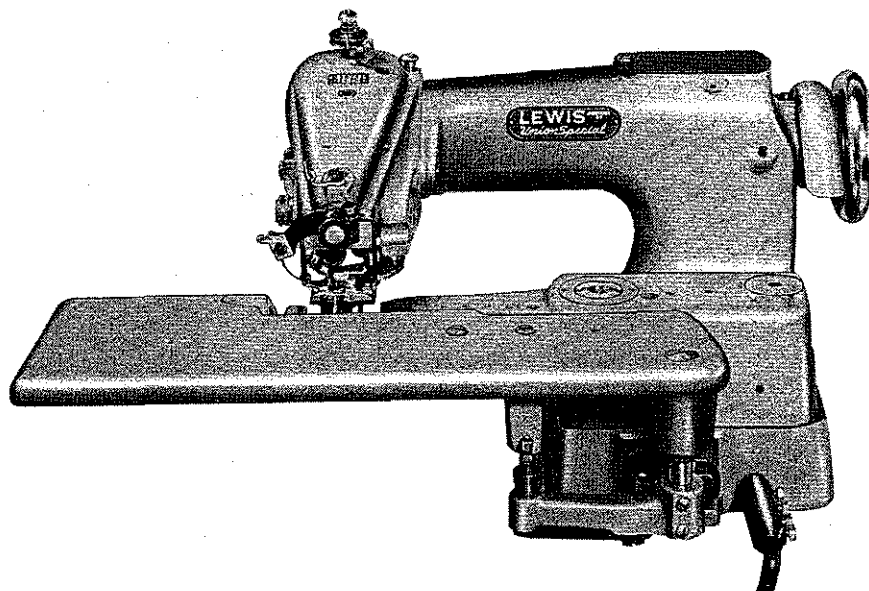

PARTS and INSTRUCTIONS

Catalogue 194-5

150 Class Machines

Models

150-1	150-9
150-5	150-15
150-6	150-16
150-6TS	150-17
150-7	150-20
	150-23

PRODUCT OF

Union Special[®] MACHINE COMPANY

400 N. Franklin St.

Chicago, Ill. 60610

LEWIS CLASS 150 MACHINES

<u>INDEX</u>	<u>PAGE</u>
Adjusting Chart	13,14
Adjusting Looper	16-19
Belt Loop Parts for 3/8" and 5/16" wide Loops.	93,94
Cylinder Base Parts and their Adjustments.	12
Feeds.	11,114
Flared Skirts.	11
Feed Plates.	115
Feed Plate Holders.	116
Folders	117
General Instructions	7-19
Hemming Flared Skirts: Parts for, See Plate 8. Parts to adjust pressure of Feed Plates.	11,53
Instructions for Belt Loop Machine	91,92
Instructions - General.	7-19
Instructions for Ordering Parts	5
Instructions for Using Catalogue.	5
Model Numbers and Serial Numbers	5
Model 150-1	44-54
Additional Parts for Model 150-1	54
Plates for Model 150-1	46-53,110
Model 150-5	56
Additional Parts for Model 150-5	56
See Plates for Model 150-1.	46-53,110

LEWIS CLASS 150 MACHINES

<u>INDEX</u>	<u>PAGE</u>
Model 150-6	58-60
Additional Parts for Model 150-6	60
Instructions for Model 150-6	57
Plates for Model 150-6.	59,111
Model 150-6TS	61-65
Additional Parts for Model 150-6TS	64,65
Instructions for Model 150-6TS	61
Plates for Model 150-6TS	63,111
Model 150-7	66-71
Additional Parts for Model 150-7	70,71
Instructions for Model 150-7	67,68
Plates for Model 150-7	69,113
Model 150-9	72-76
Additional Parts for Model 150-9	75-76
Plates for Model 150-9.	74,111
Model 150-15	77-80
Additional Parts for Model 150-15	80
Plates for Model 150-15	79,111
Model 150-16	81-93
Additional Parts for Model 150-16	86-90,93
Instructions for Model 150-16	91-92
Plates for Model 150-16	82-85,112
Model 150-17	96
Additional Parts for Model 150-17	97
See Plates for Model 150-1	46-53,111
Model 150-20	81-94
Model 150-23	98-109
Additional Parts for Model 150-23	106-109
Instructions for Model 150-23	98-100
Plates for Model 150-23	102-105,113
Needles	8
Oiling Machine	9
Parts List including all Models	20-43

LEWIS CLASS 150 MACHINES

<u>INDEX</u>	<u>PAGE</u>
Plate Numbers - See Models. See below.	
Presser Feet	9,118,119
Regulating Length of Stitch	12
Ridge Forming Disc	9,10,120
Ridge Forming Disc Regulator	10
Retainer or Cloth Clamp	19,20
Speed of Machine	9
Serial Numbers and Model Numbers.	5
Thread	8
Threading Machine	7
Timing and Adjusting Charts.	13,14
Unpacking Machine	7

LEWIS CLASS 150 MACHINES

INDEX

PLATES

<u>PLATE NO.</u>		<u>PAGE NO.</u>
1	Timing Chart.	13
1A	Timing Chart.	14
2	Parts For Model 150-1	46
3	Parts For Model 150-1	47
4	Parts For Model 150-1	48
5	Parts For Model 150-1	49
6	Parts For Model 150-1	50
7	Parts For Model 150-1	51
8	Parts For Model 150-1	52
9	Parts For Model 150-1	53
10	Additional Parts For Model 150-6.	59
11	Additional Parts For Models 150-6, 150-6TS	63
12	Additional Parts For Model 150-7.	69
13	Additional Parts For Model 150-9.	74
14	Additional Parts For Model 150-15	79
15	Additional Parts For Model 150-16	33
16	Additional Parts For Model 150-16	84
17	Additional Parts For Model 150-16	85
18	Additional Parts For Model 150-23	102
19	Additional Parts For Model 150-23	103
20	Additional Parts For Model 150-23	104
21	Additional Parts For Model 150-23	105
22	Additional Parts For Models, 150-1 and 150-5.	110
23	Additional Parts For Models, 150-6, 150-9, 150-15 and 150-17	111
24	Additional Parts For Model 150-16	112
25	Additional Parts For Models, 150-7 and 150-23	113

INSTRUCTIONS FOR USING CATALOGUE TO ORDER PARTS

The Model 150-1 Machine is the basic machine used in compiling this catalogue that is the majority of parts used in the Model 150-1, are used in all the models of the class 150 Machines.

Additional parts used to make each Model are listed under each model number.

To find a part needed, note model number on the machine for which the part is wanted, and the index will show the page number, referring to the model.

The Model No. is located on top of the head of the machine.

The Serial No. of each machine is stamped in the arm under the top cover.

State Model No. and Serial No. of machine when ordering parts.

Turn to the plate showing drawings of machine to obtain part number. If part cannot be located, then the part is common to Model 150-1, or to the model referred to at the bottom of the page of parts listed.

The parts listed and plate drawing in each model section are the additional parts used over the models referred to at the bottom of page of parts listed.

If part number is known turn to General parts list for description and best plate for locating part.

The plate drawings show only the standard parts such as presser feet, folders and etc. For parts other than standard, see lists on last pages of catalogue, also see plates, 22, 23, 24, and 25. Refer to index for following subjects:

Feeds.
Feed Plates.
Folders.
Presser Feet.
Ridge Forming Disc.

GENERAL INSTRUCTIONS FOR THE INSTALLATION,
ADJUSTMENT, AND OPERATION OF LEWIS CLASS
150 MACHINES

UNPACKING MACHINE

To remove the machine from the box, take off the cover and remove the nails and screws that hold the brace blocks in position. Use a nail puller to avoid breaking the machine. These blocks are held by nails or screws driven through the outside of the box. The knee lifter is attached to the side of the box, and the other small parts will be found wrapped in a package. Be sure to look carefully through the material used for packing before destroying it, so that you will find all the parts and equipment that goes with the machine. Lift the machine out of the box very carefully to avoid breaking the tension studs as these parts project beyond the head of the machine.

Set up the machine; clean away accumulated lint and dust, especially from the looper.

Place the machine on the bench with the pulley lined up with the transmitter, and, assemble the knee lift lever to the machine. The machine should be set on the table so that the knee lift lever is 1/2" from the edge of the table.

Mark the three holes for the machine screws and bore for the screw holes; bore the hole for the belt; place the felt pad under the machine and fasten the machine to the table, using the three machine bolts that were used to hold the machine into the packing case.

HAND WHEEL

The top rim of hand wheel turns, when facing the pulley, away from the operator or clockwise. The pulley is 2" diameter at the pitch line of the belt groove.

THREADING

From the spool stand, pass the thread through the eyelet just back of the tension disc, then between the tension disc on the left side, then lift thread over the pin which passes through the tension discs; then through the pig-tail eyelet over the needle bar, then through the hole in the needle clamp, then through the eye of the needle.

REMOVING WORK

See that the needle is out of the cloth. Lower the feed plates and retract the disc and give the work a quick jerk which will break the thread.

We reserve the right to change specifications or designs at any time without incurring the obligation to install such changes on machines previously manufactured.

NEEDLE SIZES

The needles are furnished in the following sizes, order by number:

<u>Taper Point Not Scarfed</u>	<u>Taper Point 15° Front Scarf</u>	<u>Sharp Point 15° Front Scarf</u>
29-492 1/2	29-343	29-493
	29-343 1/2	29-493 1/2
	29-344	29-494
	29-344 1/2	29-494 1/2

Ordinarily, sizes 29-343 1/2 and 29-344 will serve the purpose. A full range of needle sizes are, however, available to meet all requirements.

Use ONLY genuine LEWIS needles. Look for the copyrighted word "LEWIS" stamped on the shank of each needle.

THREAD

Use any good grade of left-twist three cord hard finish cotton thread in sizes 70 to 100. If silk thread is used, select either "00" or "000".

REGULATING DEPTH OF NEEDLE PENETRATION

The needle penetrating adjustment is located on top of the cylinder base of the machine and is a dial with graduations, showing the word "More" and indicates the direction in which to turn for raising the ridge forming disc for a deeper penetration; and the word "Less" which indicates the direction to turn the dial to obtain less needle penetration in the work.

SKIPPING STITCHES

Examine point of needle to see if it is blunt or turned over. Replacing needle will generally remedy skipping of stitches.

REPLACING NEEDLE

Insert needle into needle carrier as far as possible and tighten set screw. Needle should bear slightly on the needle guide.

IMPORTANT -- OIL MACHINE DAILY

SPEED

The LEWIS Class 150 machines can be operated up to 3000 stitches per minute. A speed of 1800 to 2000 stitches is recommended in starting a new machine or with a new operator. Speed may be increased to suit operator or class of work.

TIMING

All basic driving parts are properly timed with spot screws.

PRESSER FOOT

Place new needle in the needle carrier as far as possible and with the point directly over the needle guide adjust the foot up or down so that the point of the needle is under scant .010" tension. Observe that shank of needle passes over the needle guide freely.

RIDGE FORMING DISC (Refer to Plate 1A)

The disc must be adjusted to be in the center of the slot in the presser foot, and so that the nose of the disc is set in relation to the needle, Models 150-1, 150-6, 150-6TS, 150-7, 150-17. For other models, refer to special instructions on model in question.

Before setting the disc be sure that there is no end play to the cradle 140-11. Any end play can be taken up by adjusting the pivot bearing screw 18-869, Set Screw 1003 must first be loosened and the tension of Spring 21-377 released.

Adjust Pivot Screw 18-869 just enough to take up play but the cradle must move very freely. Check by moving cradle by hand, then lock pivot screw in place by tightening set screw 1003 to lock 18-869 in place.

Adjust tension spring 21-377 with nut 20-120. Normal setting is when the end of screw for adjusting tensions 18-909 is even with the end of nut 20-120.

To adjust the disc to center of slot in the presser foot, loosen set screw 1022 in collar 39-118 and clamp screw 1158 in crank 448-131 and set disc to slot, at the same time set the disc so that when the point of the needle is at the center of the slot in presser foot and at center of the disc, the point of the needle will be 1/16" from where the small radius on nose of the disc joins the periphery of the disc. This setting is made when the disc is at its most advanced position. Tighten clamp screw 1158 in crank 448-131 and set screw 1022 in collar 39-118 and set the collar to take up all end play in the ridge forming disc shaft.

To remove the ridge forming disc, depress the left hand feed plate holder, remove the nut 20-80 on end of disc shaft and remove the washer 40-144 and disc. When reassembling the disc, care must be taken that the key in flange 107-44 engages the slot in the disc. Assemble the washer 40-144 and nut 20-80 and tighten firmly.

RIDGE FORMING DISC REGULATOR (Refer to Plate 1A)

The dialed regulator located on top of the Cylinder Base raises and lowers the ridge forming disc to get the correct needle penetration in the work being done to form a blind stitch. The word "More" indicates more depth, and "Less" indicates less depth of needle penetration.

The regulator also limits the amount that the disc can be raised in order to protect the needle point from striking the ridge forming disc. The adjustment is made by turning the regulator in the "More" direction as far as possible to stop pin inside of the regulator.

A needle must be in the needle carrier and in contact with the needle guide and point of needle over the ridge forming disc.

Now remove the set screw 18-924 (See Plate No. 1A) and adjust screw 18-923 that contacts the cradle 140-11 in which the ridge forming disc shaft is mounted and adjust so that the ridge forming disc will lift the needle off of the needle guide .010" which is equivalent to two thicknesses of newspaper. Re-assemble the 18-924 screw and set tightly to lock screw 18-923 in place. These two screws are located inside of the main hexagon headed adjusting screw 18-922.

The adjustment for the spring tension for correct pressure of ridge forming disc is made by turning nut 20-120, located in front of cylinder base, turn in clockwise direction to get more tension and in reverse direction for less tension.

FEED

The feed is adjustable relative to the presser foot by loosening the two binding screws holding the feed, and turning over the machine, away from you, until the feed motion is at the lowest point, then set the feed so that it is $1/32$ " below and parallel with the bottom of the presser foot, for light and medium weight materials; for heavy work, the feed must be brought below the presser foot about $3/64$ ".

The feed is adjustable from three to eight stitches per inch.

FEED PLATES

The Feed Plates press the work against the bottom of the presser foot and feed, when on its feeding stroke by two springs.

There must be enough pressure applied to hold the work from moving when the needle penetrates the material, for if the material moves with the needle, a loop will not be formed for the looper, resulting in skip stitches.

Check to see that Feed Plates clamp a piece of newspaper before point of needle penetrates material.

For sewing flared skirts with wide hems, the pressure applied for each feed plate can be varied so the machine will feed in the fullness in this type of hem if the operator holds back slightly on the hem.

ADJUSTING LENGTH OF STITCH

The stitch is regulated by the knob 426-47, Plate 3, located on top of the arm of the machine, near the head. First, open the top cover of the machine to observe the feed indicator on the shaft, with numerals which indicate the number of stitches per inch, press down the feed knob located on top of the machine, which will engage a slot in the feed mechanism; now turn the hand wheel over and away from you while holding the knob in the slot to lengthen stitch, and toward you to shorten stitch, and observe through the opening in the top of the arm, the number on the feed disc as you turn until the numeral, indicating the stitches per inch, is directly under the indicator.

CYLINDER BASE PARTS AND THEIR ADJUSTMENT (See Plate 1A)

The parts in the Cylinder Base and base of arm operate the ridge forming disc, depress the feed plate and retract the disc to insert and remove the work from the machine.

Parts in the Cylinder Base where possible are held in position with spot screws and a timing mark has been milled in the bracket 50-222. Parts assembled in this bracket that have timing marks that must match the timing mark in the bracket are Eccentric 433-151 and Gear 27-165.

Bracket 50-222 can be removed from the machine by removing Stud 17-145 which will disconnect the end of Connecting Rod 447-118 from Lever 45-352. Next remove the three Screws 18-664 and take bracket from the base by slipping the headless bearing Stud 865 out of the hole in Ball Joint 4124-51.

Gear 27-166 and Eccentric 433-151 are held on to the Shaft 14-458 by the Spot Screws 1025 and 18-624, therefore when assembling, if the gear teeth are engaged so that the timing marks all coincide, the machine will function properly.

Crank 448-131 is clamped to the disc shaft and is used to adjust the ridge forming disc. (See Plate 1A)

Crank 48-127 is for adjusting Shaft 14-429 for depressing feed plates. The adjustment is made through a hole in front of cylinder base. Loosen screw CS 331 in crank 48-127 and with feed plates in contact with presser foot, adjust surface (A) of 14-429 so that two thicknesses of newspaper will just pinch against the contact surface of feed plate holders. See (A) plate 1A. Be sure feed plates are in contact with bottom of presser foot.

Check the above setting by depressing the feed plates as far as possible, and turn over hand wheel, and see that crank, 48-127 turns without interfering with adjacent parts.

TURN IN DIRECTION OF ARROW FOR MORE OSCILLATION TO NEEDLE AND LARGER THREAD LOOP

ADJUSTING CHART LEWIS CLASS 150 SINGLE THREAD MACHINE

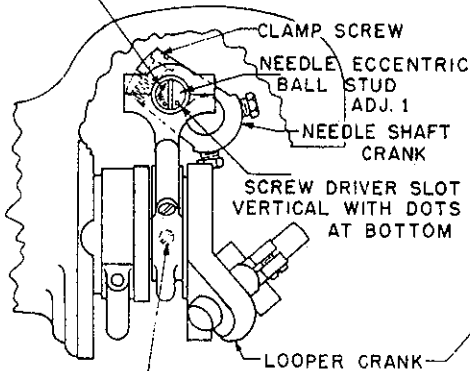

FIG. 1

SPOT SCREW IN ECCENTRIC FOR TIMING NEEDLE AND IS SET AT THE FACTORY

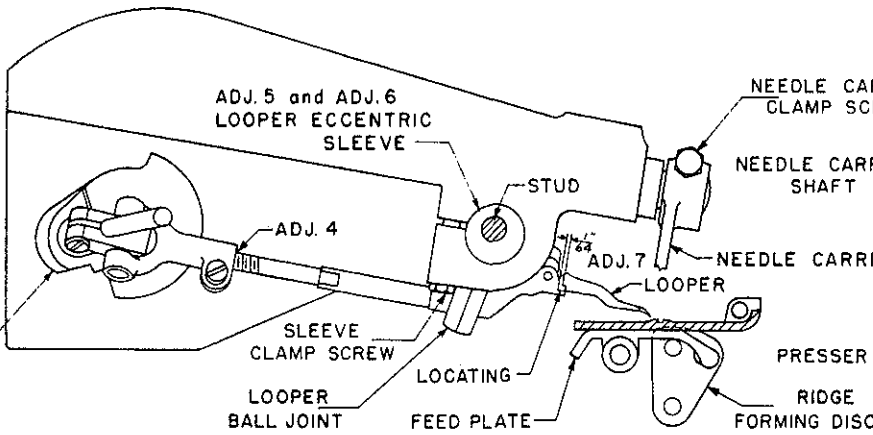

FIG. 2

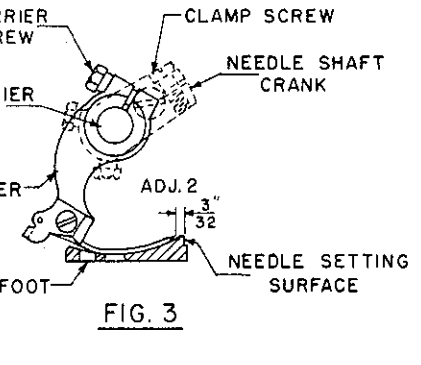

FIG. 3

POSITION OF TIMING MARK WITH EDGE OF "V" GROOVE

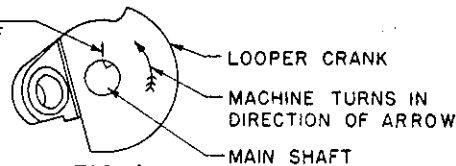

FIG. 4

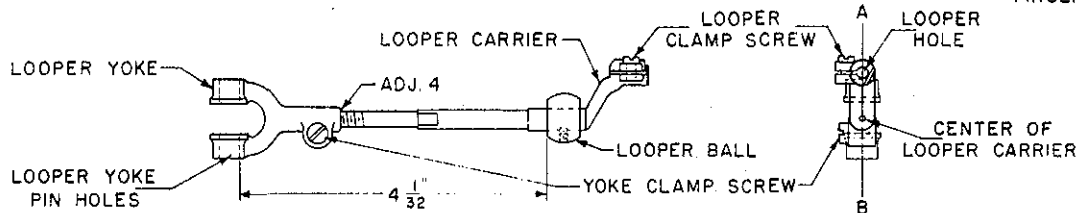

FIG. 5

FIG. 6

MUST CLEAR CHAINING FINGER NOT OVER $\frac{1}{32}$

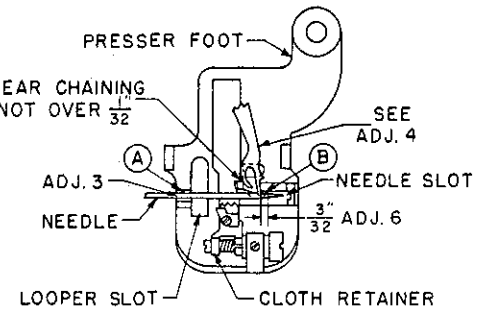

FIG. 7

TIMING & ADJUSTING CHART LEWIS CLASS 150 SINGLE THREAD MACHINE

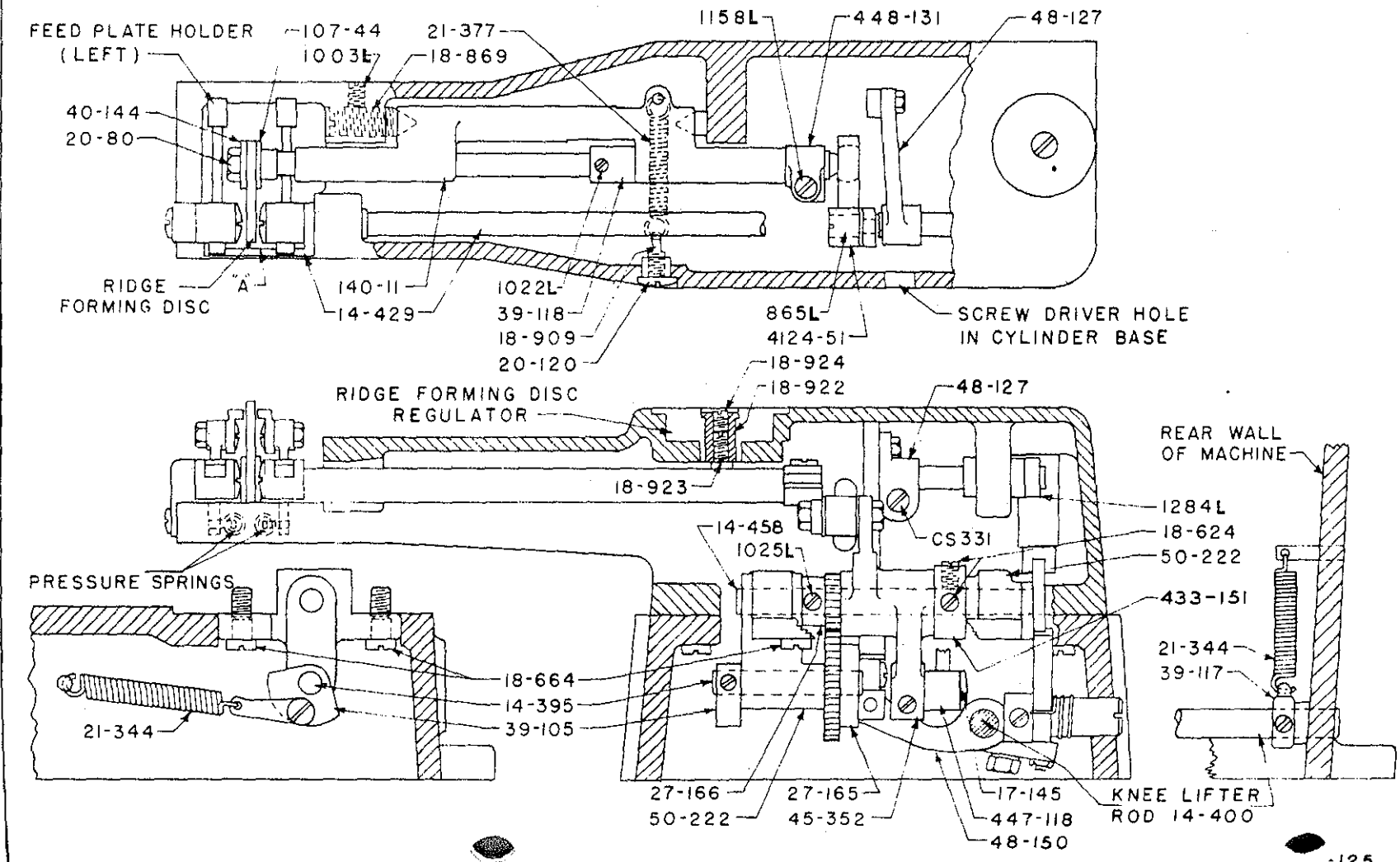

PLATE 1A

Crank 48-150 is for adjusting the position of the Knee Lifter in best position for operator.

Collar 39-105 is used for taking up end thrust of Shaft 14-395 and setting tension of Spring 21-344 for returning ridge forming disc and feed plates to sewing position.

Collar 1284 is used for taking up end thrust of Shaft 14-429.

Collar 39-117 is used to take up end thrust of knee press Shaft 14-400 and for setting tension of Spring 21-344 for holding knee lifter out of contact with depressing lever.

TIMING THE MACHINE

Needle:

A No. 4 taper point needle should be used when adjusting the needle position.

To secure the correct adjustment for the needle swing the following steps must be taken and settings made. (See adjusting chart). Plate 1.

Adjustment 2

To set the point of the needle in the correct position when the needle is at the extreme end of its stroke towards the hand wheel, the following steps must be taken: Turn the machine over until screw driver slot in the needle eccentric ball stud is straight up and down with the two dots at the bottom. See Figure 1. With the machine in the above position, loosen the needle carrier clamp screw and move the needle carrier so that the point of the needle is $1/16''$ to $3/32''$ from the edge of the needle setting surface. See Figure 3. Tighten the needle carrier clamp screw.

Adjustment 3

To set the needle in the correct position in the needle slot - See Figure 7 - the following steps and setting must be made: Loosen the needle carrier clamp screw and move the needle carrier - See Figure 2 - in or out so that the rear side of the needle will just clear the needle slot at "A" - See Figure 7 - and clear the needle shoulder of presser foot at "B" about $.005''$. Check to see that the setting for the needle point still is $1/16''$

to 3/32" from the needle setting surface of presser foot. Tighten the needle carrier clamp screw.

LOOPER

The correct setting of the looper is of the greatest importance. (See adjusting chart). Plate 1.

The looper is mounted in the looper carrier assembly - allow 1/64" space between looper shoulder and end of looper carrier - See Figure 2 - and the correct assembling of this unit must be understood in case for any reason it is necessary to remove or replace this assembly.

The looper carrier assembly consists of:

Looper Yoke - in which are the looper yoke pin holes
Clamp Screw
Looper Ball
Looper Carrier

The looper carrier and looper yoke are set before assembling these parts into the machine. Now, the looper ball is positively located on the shaft of the looper carrier by a spot screw. The looper carrier is assembled to the looper yoke so that the distance from the edge of the looper yoke pin hole nearest the looper ball, to the side of the looper ball nearest to the looper yoke, will be 4-1/32". See adjusting chart - Figures 5 and 6.

The looper has means for the following adjustments, which, for reference to the drawing, are numbered as follows:

Adjustment 4

Means for adjusting the looper position on the right hand side or when the looper is taking the loop from the needle.

Adjustment 5

Means for adjusting the looper position on the left hand side or when the needle is between the prongs of the looper.

Adjustment 6

Means for adjusting the position of the looper from left to right or right to left.

Adjustment 7

Means for adjusting the looper in and out.

Before setting the looper, the looper carrier assembly must be in accordance with instructions for Figure 5 and Figure 6 and the needle setting must be as described in adjustments 1, 2 and 3.

The looper is and can be timed at only one place.

TIMING THE LOOPER

Timing the looper is relative to the needle. Loosen the two set screws on the looper crank. To time the looper, turn the machine over by the hand wheel by turning the hand wheel towards the rear of the machine until the screw driver slot in the needle eccentric ball stud is straight up and down with the two dots at the bottom - See Figure 1, adjustment 1.

There is a "V" notch cut in the main shaft of the machine which will be at the top of the shaft.

There is a timing mark on the looper crank - See Figure 4.

Turn the looper crank until the timing mark on the crank coincides with the left hand edge of the "V" on the main shaft. This timing mark will not vary more than $1/32$ " plus or minus relative to the edge of the "V".

Clamp the looper crank to the main shaft of the machine with the two set screws.

ADJUSTING AND SETTING THE LOOPER

To secure the correct adjustment of the looper, the following steps should be taken and in the same sequence as here given:

The looper is first adjusted as the looper is taking the loop from the needle.

The position for the long prong of the looper is to have the point of this prong $3/32$ " from the inner end of the needle eye and the point of the long prong just clearing the scarf of the needle.

To secure this setting, the following steps and adjustments are taken and made:

Turn the hand wheel in clockwise direction; that is, the top of the hand wheel will be moved away from the operator very slowly until the long prong of the looper is over the center line of the needle.

Loosen the looper yoke clamp screw - See Adjustment 4, Figures 2 and 5 - and roll the looper until the long prong of the looper just clears the scarf of the needle.

Loosen the sleeve clamp screw - See Figure 2 - this permits the looper eccentric sleeve to be moved from left to right - and slide the looper eccentric sleeve - Figure 2, adjustment 6, until the long prong of the looper is $3/32''$ from the inner end of the needle eye.

Check to see that point of the long prong of the looper just clears the scarf of the needle. Tighten the looper yoke clamp screw - See Figure 5, and the looper eccentric sleeve clamp screw - See Figure 2.

Continue to rotate the hand wheel in clockwise direction, until the short prong of the looper is at nearest point when passing chaining finger, if foot has chaining finger, not exceeding $1/32''$ - See Figure 7. If the short prong does not clear the chaining finger, or if the clearance is greater than $1/32''$, then the previous adjustments have not been correctly made, and these should be re-made.

Continue to rotate the hand wheel in clockwise direction until the short prong of the looper has passed the edge of the looper slot in the foot. If the short prong of the looper does not enter the looper slot in the foot, adjust so that the short prong will clear the edge of the looper slot in the foot by moving the looper eccentric sleeve - Adjustment 6, Figure 2. Move the looper eccentric sleeve the least amount possible so that the short prong clears the edge of the looper slot.

Care must be taken now as the needle may strike the crotch of the looper when the needle should be entering between the prongs of the looper.

Continue to turn the hand wheel in clockwise direction until the point of the needle should enter between the prongs but instead of so doing strikes the crotch of the looper - the following corrective steps are required:

Loosen the two set screws on the looper crank - See Figure 4, and turn crank slightly in a clockwise direction until the needle does not strike the crotch. Tighten the set screws.

The needle must enter between the prongs of the looper, clearing the two prongs about an equal amount.

In case the needle should not enter about midway of the two prongs - to correct this, loosen the sleeve clamp screw - Figure 2, and turn the looper eccentric sleeve - Adjustment 5, Figure 2, until the prongs of the looper are about an equal distance from the needle. When this setting has been made, tighten the sleeve clamp screw - See Figure 2.

Continue to rotate the hand wheel in a clockwise direction until the point of the long prong of the looper is over the center line of the needle. Check to see that the point of the long prong of the looper is $3/32$ " from the inner end of eye of the needle and that the point of the long prong just clears the scarf of the needle. In case the above conditions do not exist, they must be corrected - this is done as described in the fifth to tenth paragraphs inclusive under the heading "ADJUSTING AND SETTING THE LOOPER". Be sure to roll the looper - Adjustment 4, Figure 5. Do not turn the looper eccentric sleeve.

The machine, as far as the looper and needle are concerned, is now ready to sew. Different material or different threads may cause a slight variation from the above adjustments. However, these adjustments will give the best results when padding or hemming the more heavy materials. When hemming silks and cotton, however, it may be advisable to set the point of the needle $1/16$ " from the needle setting surface on the presser foot - Figure 3, instead of $3/32$ ", without changing the looper position by re-adjusting the needle ball stud - Adjustment 1, Figure 1 - the timing dots on the ball stud should be turned in direction towards the hand wheel to obtain slightly more throw to the needle resulting in a larger thread loop.

RETAINER OR CLOTH CLAMP

The Cloth Retainer located in the cloth opening of the presser foot must at all times be adjusted as close to the needles as possible and set relative to the ridge forming disc to firmly hold the work on to the disc while the needle is penetrating the material. If the work is carried along with the needle, no loop will form, resulting in missed stitches.

PARTS LIST FOR LEWIS CLASS 150 MACHINES

<u>Part No.</u>	<u>Plate</u>	<u>Description</u>
4-C114	20	Work Plate (large) for Models 150-7 and 150-23
4-121	15, 16	Aluminum Work Plate attached to bracket 50-234 for Model 150-16, 150-20
4-126	8	Work Plate (swing type) in 404-126 when end cover 32-264 is used. Models 150-1, 150-15
4-127	-	Work Plate (swing type) in 404-127 when using 32-264 Model 150-9
6-56	22, 23, 24, 25	Needle Guide
6-70	17	Needle Guide, Model 150-20
8-89	4	Belt Guard
8-122	16, 24	Guard for right hand top knife, Model 150-16, 3/8"; Model 150-20, 5/16"
8-123	15, 16, 24	Guard for left hand top knife, Model 150-16, 3/8"; Model 150-20, 5/16"
8-124	24	Guard for right hand top knife in 5/16" belt loops, Model 150-16
8-125	15, 24	Guard for left hand top knife for 5/16" belt loops, Model 150-16
8-128	16	Guard for right hand top knife, Model 150-20, 3/8"
8-129	15, 16	Guard for left hand top knife, Model 150-20, 3/8"
14-14	3	Shaft for Needle Carrier 4118-24
14-260	8	Shaft in Bracket 50-211 for swinging Work Plate 4-126, 4-127
14-394	5, 19, 20, 21	Shaft for Ridge Forming Disc in Cylinder Base 150-1, -5, -6, -7, -9, 150-15, -17, -23
14-395	4, 6, 7	Shaft in Base for Gear 27-165
14-400	6, 9	Shaft for Knee Press
14-429	4, 5, 6, 9	Shaft in Base to depress Feed Plates for 150-1, -5, -7, -9, -15, -16, -17, -20, 150-23
14-432	2, 4	Main Shaft
14-434	10, 11	Shaft in Base for Feed Plate Holders Models 150-6, 150-6TS
14-435	10, 11	Shaft for Ridge Forming Disc in Cylinder Base - Model 150-6TS
14-440	20, 21	Shaft for Crank 48-138 to shog disc Model 150-23
14-441	21	Jack Shaft in Arm - Model 150-23

PARTS LIST FOR LEWIS CLASS 150 MACHINES

<u>Part No.</u>	<u>Plate</u>	<u>Description</u>
14-458	4, 7, 9	Shaft in Base for oscillating disc Lever 45-352
16-39	3	Needle Shaft Bushing Front End of Head
16-148	3	Needle Shaft Bushing, Rear end of Head
16-194	3	Bushing in Arm for 26-47 to change length of stitch
16-196	2, 4	Bushing for Main Shaft 14-432 Head end of Arm
16-214	17, 22, 24, 25	Bushing in Presser Feet for adjust- ing Cloth Retainer
16-239	6	Bushing in Base for Knee Lift Rod
16-255	21	Bushing (eccentric) in Arm for Ad- justing Gear 27-215, use set screw CS317
16-279	2, 5	Bushing in Head for Eccentric Stud 17-114 for adjusting height of feed and in Cylinder Base for 14-429
16-317	2, 4	Bushing for Main Shaft, Hand Wheel End of Arm
16-322	20, 21	Bushing in base for 14-440 for shogging disc Model 150-23
16-329	21	Bushing for Main Shaft Hand Wheel end of Arm, Model 150-23
17-87	17, 22, 24, 25	Eccentric Stud in Bushing 16-214 for adjusting Cloth Retainer
17-111	25	Eccentric Stud for adjusting Crowns 126-43 and 126-47 on presser feet 405-514 and 405-558
17-113	25	Stud for Crown 126-36 on Presser Foot 405-409-1 and 405-522 Model 150-7
17-114	2	Eccentric Stud in Head for Link 446-118
17-145	4, 6	Stud in Lever 45-352 for Connecting Rods 447-118 and 447-125
17-146	2, 3	Stud for Looper Ball Joint Sleeve 70-53
17-149	2	Stud in Looper Drive Crank 48-135 for Looper Bearing
17-150	2, 3	Stud for Feed Lever in Head
17-153	15, 16, 24	Stud for Plunger Link 46-157 in Cylinder Base, Model 150-16, 150-20
17-157	9	Eccentric Stud for adjusting Latch for Disc Locking Mechanism
18-38	4, 15, 24	Screw for Indicator 155-9 and for attaching 110-236, 110-237 to trim- mer bracket, Model 150-16

PARTS LIST FOR LEWIS CLASS 150 MACHINES

<u>Part No.</u>	<u>Plate</u>	<u>Description</u>
18-70	3	Clamp Screw for needle carrier 4118-24
18-71	2	Clamp Screw for looper yoke 449-27
18-74	3	Spot Screw in 479-8 to locate on looper carrier 4118-15
18-C110	13, 14	Screw for attaching folder bracket 50-223 to presser feet 405-497, 405-537, 405-538, Models 150-9 and 150-15
18-121	8	Screw in shaft 14-260 for work plate
18-125	11	Screw for Spring 21-332 Model 150-6TS
18-C186	13, 14	Set Screw for collar 39-C255 for locating folders, Models 150-9, 150-15
18-261	13	Screw for attaching 1733 L to 50-280 L
18-270	17, 22, 24	Screw in end of eccentric stud 17-87
18-277	8	Screw in work plate for holding folders
18-281	23	Screws for attaching roll forming plate 110-230 to presser feet, Models 150-6 and 150-6TS
18-292	22, 23, 25	Screw for holding chaining fingers to presser feet
18-295	10, 11	Bearing Screw for feed plate in cylinder base, Models 150-6 and 150-6TS
18-307	3, 17	Screw for holding presser foot to bracket 50-160, and for 22-257, Model 150-16, -20
18-318	12, 18, 19, 21, 25	Screw for attaching ridge forming disc 44-275 to plunger 26-152 in cylinder base, Models 150-7 and 150-23
18-326	6	Screw for clamping 39-117 collar to knee lift shaft in base of arm
18-330	2, 13, 14	Screw for cover 32-107 on head, screw for bracket 50-223, Models 150-9 and 150-15
18-345	25	Screw for presser foot 405-409-1, 405-514, 405-522, 405-558
18-355	4	Screw for 107-51 ridge forming disc regulator in cylinder base
18-375	16	Screws for top knives, Model 150-16, 3/8 inch; Model 150-20, 5/16 inch
18-391	3, 15	Screw for 447-97-1 in head, screws in 4124-56 and 447-23, Model 150-16
18-400	16	Screws for top knives, Model 150-20, 3/8 inch
18-416	17, 22, 24, 25	Screw in bushing 16-214 for holding eccentric stud 17-87 in presser foot
18-492	2	Spot Screw for eccentric 433-93 in head
18-493	6	Screw for 70-28 sleeve for knee press
18-500	9	Set Screw in base for locking eccentric stud 17-157

PARTS LIST FOR LEWIS CLASS 150 MACHINES

<u>Part No.</u>	<u>Plate</u>	<u>Description</u>
18-561	20	Screw for 4124-55 Ball Joint in Base, Model 150-23
18-565	2	Screw for Aluminum Head Cover
18-602	15	Screw in Stitch Regulator 149-16 to limit length of stitch Model 150-16, -20
18-622	13	Screw for Folder Spring 21-385, Model 150-9
18-623	22	Screw for Cloth Retainer Stop on Presser Foot
18-624	4	Screw for Eccentric 433-151 in Cylinder Base
18-628	7, 8	Screws for Feed Plate Springs 21-75 and 21-375
18-643	17, 22, 23, 25	Screw for Needle Guide on Presser Foot
18-644	2	Screw for 40-151 in Arm
18-647	7	Screw for Spring Link 46-148 in Cylinder Base
18-657	13, 14, 15, 17, 24	Screw for Clamping Folders to Foot, Models 150-9 and 150-15. Screws (2) for Plate 110-295. Model 150-16
18-662	2	Screw for clamping Looper Adjusting Sleeve 70-53 in Head
18-664	2, 4, 7	Screw to hold Head to Arm, Cylinder Base to Arm, and Bracket 50-222 to bottom of Cylinder Base
18-674	2	Screw in Stitch Regulator 149-16 in Head
18-700	2, 4, 21	Spot Screw for Ridge Forming Disc Eccentric 433-144 in Arm
18-701	5	Spot Screw for Pivot Bearing 117-41 in Cylinder Base
18-702	3	Hex Head Spot Screw for Needle Drive Crank 48-105 in Head
18-715	15	Screw for Knife Drive Link 46-155 under Head, Model 150-16, 150-20
18-732	2	Screw for Feed
18-737	2	Screw for Looper Driving Crank 48-135 in Head
18-738	2, 15	Screw for Pin Shaft 22-8 in Looper Yoke 449-27 and for holding 17-153 in Model 150-16
18-744	25	Knurled Screw for adjusting Crowns on Presser Feet
18-749	9	Screw for adjusting Crank 48-150

PARTS LIST FOR LEWIS CLASS 150 MACHINES

<u>Part No.</u>	<u>Plate</u>	<u>Description</u>
18-750	10, 11	Screw for Cylinder Base Cover, Models 150-6 and 150-6TS
18-750	*	Screw for 75-212, Model 150-5
18-751	3	Hex Screw in Link 446-118 to clamp Eccentric Stud 17-114 in Head
18-757	21	Hex Screw for 448-139 in Base, Model 150-23
18-764	4	Screw on top of arm to plug tension release hole
18-766	3	Screw for cap of large ball end of 447-97-1 Joint in Head
18-767	2, 3	Screw for clamping Stud 17-150 for feed lever in Head
18-869	5	Pivot Bearing Screw for Disc Cradle 140-11 and 140-12 in Cylinder Base
18-870	5, 6, 9	Hex Shoulder Screw in Link 46-164 to connect Cranks 48-127 and 48-150 in Base
18-872	5, 13, 16	Shoulder Bearing Screws for Feed Plate Holders in Cylinder Base
18-892	5	Stop Screw for Regulator 149-28 on top of Cylinder Base
18-895	5	Hinge Screws for regulator Handle 76-12 on top of Cylinder Base
18-900	5	Screws for cap of ball joint 4124-51 in Cylinder Base
18-906	20	Flat Head Screws to fasten Work Plate, 4-C114, to Bracket
18-909	5	Screw for adjusting spring tensions for Cradle 140-11 and 140-12 in Cylinder Base
18-C911	14	Screw for Hemmer Bracket on Presser Foot, Model 150-15
18-918	4, 12, 18, 19	Taper Bearing Screws for Feed Plates in Cylinder Base
18-919	6, 9, 20	Hex Clamp Screw for Crank 48-150 and 48-151 in Base of Arm
18-920	5, 9	Flat Head Screw for 42-25 and 97-17 on top of Cylinder Base
18-921	5	Flat Head Screws for Regulator Dial Plate 110-224 on top of Cylinder Base
18-922	4	Adjusting Screw in Regulator 107-51 to adjust depth of Needle Penetration
18-923	4	Adjust Screw in 18-922 Screw to limit height that disc can be raised

PARTS LIST FOR LEWIS CLASS 150 MACHINES

<u>Part No.</u>	<u>Plate</u>	<u>Description</u>
18-924	4, 5	Set Screw in Regulator to lock 18-923 in place
18-934	*	Screw for 32-292, Model 150-9
18-937	13, 14	Shoulder Bearing Screw for Feed Plate Models 150-9, 150-15 and 150-20
18-939	8, 20	Hex Screws for Work Table Brackets 50-211 and 50-227
18-941	19, 20	Screw for Crank 48-138 to Shog Disc in Base, Model 150-23
18-942	12, 18, 19	Shoulder Bearing Screw for Feed Plate Holder 99-303, Models 150-7 and 150-23
18-943	18, 19, 20, 21	Shoulder Bearing Screw for Connecting Rod 47-119, Model 150-23
18-951	17	Screw for adjusting Knife Pressure, Models 150-16, 150-20
18-952	15, 16, 24	Bearing Screw for Plunger in Cylinder Base, Models 150-16, 150-20
18-955	*	Screws for holding machine to Bench
18-956	16	Flathead Bearing Screws for Feed Plates Model 150-16
18-957	16, 24	Screws for Top Knives, Model 150-16, 5/16"
18-974	*	Screw for thread guide 41-48
18-1031	*	Screw for 48-141 Model 150-16, 150-20
20-31	*	Nut for 4118-15
20-34	*	Nut for 68-21
20-35	9, 20, 21	Nut for Screw 18-749 and Nut for Bearing Pin 22-254 in Cylinder Base, Model 150-23
20-60	3	Nut on head to adjust thread tension
20-79	*	Nut on Plunger 426-47 in head for changing length of stitch
20-80	5, 12	Nut for locking Ridge Forming Disc on Shaft in Cylinder Base
20-120	5	Nut to adjust pressure of Ridge Forming Disc in Cylinder Base
20-122	12, 21, 25	Nut for Plunger 26-152 in Cylinder Base, Models 150-7 and 150-23
20-129	7, 8	Adjusting nuts for applying tension to Feed Plates
20-142	*	Adjusting Nut for 68-21
21-58	17	Tension Spring for lower Knives, Model 150-16, 150-20
21-63	23	Spring for Retainer 4137-126 on Presser Foot
21-75	4, 7, 8	Springs for Feed Plate Holders
21-193	17, 22, 24	Spring for Cloth Retainers on Presser Feet

PARTS LIST FOR LEWIS CLASS 150 MACHINES

<u>Part No.</u>	<u>Plate</u>	<u>Description</u>
21-213	2	Spring for Ball 79-31 in Stitch Regulator 149-16 in Head
21-240	25	Spring for cloth Retainer on Presser Feet 405-514, 405-556, 405-558, Model 150-23
21-243	25	Spring for Adjusting Screw on Presser Feet with Crown
21-250	8	Long Spring on Bracket 50-211 for Pin
21-251	8	Short Spring on Bracket 50-211 for Pin 22-189 in Work Plate Assembly 404-126
21-C269	14	Hemmer Spring on Presser Foot 405-497 when using Folders 431-149, 431-150 and 431-159
21-C269-1	*	Hemmer Spring for Folders 431-147, 431-148, Model 150-15
21-274	9	Spring for Latch 51-21 for Locking Disc
21-300	5	Spring for Ball 79-31 in Ridge Forming Disc Regulator on top of Cylinder Base
21-332	11	Spring on Ridge Forming Disc 44-269 to locate Eccentric 33-150 in Cylinder Base, Model 150-6TS
21-341	12, 21, 25	Spring for Plunger 26-152 for Ridge Forming Disc in Cylinder Base, Models 150-7 and 150-23. For heavy Spring (See 21-357)
21-344	6, 7	Spring for Collars 39-117 and 39-105 in Base of Arm
21-348	16	Spring Finger for starting material through Folder, Model 150-16
21-357	25	Spring (heavy) for 26-152, Models 150-7 and 150-23
21-375	10, 11	Heavy Spring for Feed Plate Holder, Model 150-6 and 150-6TS
21-377	5	Spring for Cradle in Cylinder Base
21-385	13	Folder Spring for Folder 431-175, Model 150-9
21-422	*	Thread Nipper Spring
21-426	*	Tension Release Plunger Spring
22-8	2	Pin for Looper Yoke 449-27 in Head
22-9	25	Pin for Needle Carrier 4118-24 in head and for Crown 126-36, Model 150-7
22-149	2	Taper Pin for locating Head on Arm
22-152	4, 21	Spring Pin for Feed Plate Holders in Cylinder Base

PARTS LIST FOR LEWIS CLASS 150 MACHINES

<u>Part No.</u>	<u>Plate</u>	<u>Description</u>
22-189	8	Spring Pin in Bracket 50-211 for Retaining Swing Work Plate 404-126
22-248	11	Pin in Eccentric 33-150 and Lever handle 45-345 to operate Step Ridge Forming Disc in Model 150-6TS
22-249	5	Stop Pin in 107-51 for Ridge Forming Disc Regulator 149-28 on top of Cylinder Base
22-254	21	Bearing Pin for 48-138 in Cylinder Base, Model 150-23
22-255	6	Spring Pin in Collar 39-117 for Spring 21-344 in Cylinder Base
22-256	6, 7	Spring Pin in Base of Arm for Spring 21-344
22-257	17	Pin in Crank 48-141 for driving lower Knives, Model 150-16, 150-20
22-262	17	Spring Pin for 21-58, Model 150-16, -20
22-263	20	Pin for Spring 21-344 in Arm, Model 150-23
22-271	4, 5	Pin for Spring 21-377 in Base
22-286	17	Pin in Crank 48-141 for driving lower Knives, Model 150-20
22-314	*	Automatic Tension Release Pin
23-216	2, 10, 11, 22, 23, 25	Feed 3/32 Pitch for Models 150-1, 150-5, 150-6, 150-6TS, 150-7
23-217	23, 25	Feed 3/32 Pitch for Model 150-23 and 150-17
23-225	14, 23	Feed 1/16 Pitch for Model 150-15
23-301	15, 24	Feed for Model 150-16
23-310	13, 23	Feed 3/32 Pitch for Model 150-9, 1/4" Seams
23-311	13, 23	Feed 3/32 Pitch for Model 150-9, 3/8" Seams
24-263	4, 22	Feed Plate (left) for Models 150-1, 150-5, 150-17
24-264	4, 22	Feed Plate (right) for Models 150-1, 150-5, 150-17
24-265	12, 18, 19, 21, 25	Feed Plate (left) for Models 150-7 and 150-23
24-266	12, 19, 21, 25	Feed Plate (right) for Models 150-7 and 150-23
24-270	10, 11, 23	Feed Plate for roll padding, Models 150-6, 150-6TS
24-272	14, 23	Feed Plate for roll hemming, Model 150-15

PARTS LIST FOR LEWIS CLASS 150 MACHINES

<u>Part No.</u>	<u>Plate</u>	<u>Description</u>
24-277	16, 24	Feed Plate, Right Hand Side, Model 150-16
24-278	16, 24	Feed Plate, Left Hand Side, Model 150-16
24-294	13, 23	Feed Plate, Model 150-9, 1/4" Seams
24-295	13, 23	Feed Plate, Model 150-9, 3/8" Seams
24-300	*	Feed Plate, Model 150-20
26-47	3	Plunger in Arm for adjusting length of stitch. (See 426-47)
26-152	12, 18, 21, 25	Plunger for holding Ridge Forming Disc 44-275, Models 150-7 and 150-23
26-160	15, 16, 17, 24	Plunger for Node in Cylinder Base, Model 150-16, 150-20
27-76	20, 21	Gear on Main Shaft for driving gear 27-215, Model 150-23
27-165	4	Gear (large) for rolling back Ridge Forming Disc in Base of Arm
27-166	4	Gear (small) for rolling back Ridge Forming Disc in Base of Arm
27-215	18, 20, 21	Gear for Shogging Disc, Model 150-23
30-52	3	Needle Clamp
30-68	13	Spring Clamp for Folder Model 150-9
30-C258	14	Clamp for Hemmer Spring on Presser Foot, Model 150-15
32-106	2	Cover, Aluminum, for Head
32-107	2	Cover Plate (rear) for Aluminum Head Cover 32-106
32-208	11	End Cover for Cylinder Base, Model 150-6TS
32-210	10	End Cover for Cylinder Base, Model 150-6
32-225	12	Cover for end of Cylinder Base, Models 150-7 and 150-23
32-229	15, 16	Cover for Bottom of Bracket 50-234, Model 150-16, 150-20
32-262	2	Cover, Aluminum, for Head
32-264	8	Cover for End of Cylinder Base, Models 150-1, 150-5, 150-9, 150-15, 150-17
32-292	4	Cover for Top of Arm

PARTS LIST FOR LEWIS CLASS 150 MACHINES

<u>Part No.</u>	<u>Plate</u>	<u>Description</u>
33-149	2	Eccentric for Feed Lever to adjust length of stitch in Head
33-150	11	Eccentric to adjust supplementary Ridge Forming Disc 44-270 for through stitching, Model 150-6TS
34-31	*	Automatic Tension Release Pin Raising Cam
34-48	20, 21	Cam for Shogging Ridge Forming Disc, Model 150-23
35-21	4	Roll for turning Gear 27-165, to roll back Ridge Forming Disc in base of Arm
36-16	3	Looper in Head
39-87	*	Stop Collar
39-92	2, 4, 8	Collar on Main Shaft, in Swing Work Table 404-126 and Plunger Gear
39-95	16, 24	Collar for Plunger Link Stud 17-153 in Cylinder, Base, Model 150-16, 150-20
39-99	6	Spacing Collar on Shaft 14-440 in Base of Arm
39-105	4, 7	Collar on Shaft 14-395 in Base of Arm
39-117	6	Thrust Collar on Shaft 14-400 in Base of Arm
39-118	5, 16	Collar on Ridge Forming Disc Shafts 14-394, 414-449 in Cylinder Base
40-26	20	Washers for Screw 18-939 for attaching Bracket 50-227 to machine
40-38	*	Washer for pants bottom Edge Guide 75-212 on Cylinder Base, Model 150-5
40-57	19	Slap Washer for 4124-55, Model 150-23
40-60	3	Fiber slap washer on Ball 79-28 in Head
40-63	17	Fiber slap washer for 4124-56 Ball Joint under head, Model 150-16, 150-20
40-126	2	Lock Washers on feed screws in Head
40-144	5	Washer for Nut 20-80 in end of Ridge Forming Disc Shaft in Cylinder Base
40-148	5	Spacing Washer for Ball 79-9 in Crank 448-131 in Cylinder Base
40-151	2	Washer on Eccentric 433-144 on Main Shaft in Arm
40-154	14	Washer between Feed Plate 24-272 and Holder 99-298 in Cylinder Base Model 150-15

PARTS LIST FOR LEWIS CLASS 150 MACHINES

<u>Part No.</u>	<u>Plate</u>	<u>Description</u>
40-159	19, 21	Washer for Ball in Crank 448-137 in Cylinder Base, Model 150-23
41-1	3	Thread Guide on needle end of Head
41-42	3	Thread Guide under tension staff 468-23-1 on Head
41-48	*	Thread Guide, screw 18-974, LS314
41-49	*	Thread Guide, screw LS314
42-13	22	Stop for cloth retainers on Presser Foot 405-508
42-24	22	Stop for cloth retainers on Presser Feet 405-393-2, 405-394-4, 405-394-5, 405-394-8, 405-395-1, 405-419, 405-502 and 405-529
42-25	9	Stop Pin in Cylinder Base
44-253	22, 23	Ridge Forming Disc, Models 150-1, 150-17
44-269	11, 23	Ridge Forming Disc for through stitch, Model 150-6TS
44-270	11, 23	Supplementary Ridge Forming Disc for through stitch, Model 150-6TS
44-272	14, 23	Ridge Forming Disc, for rolled hem, Model 150-15
44-275	12, 18, 21, 25	Ridge Forming Disc, yielding, for fur padding, and bluff edge Models 150-7 and 150-23
44-276	10, 23	Ridge Forming Disc for Roll Padding, Model 150-6
44-277	22	Ridge Forming Disc used with foot 405-508 on tropicals and rayons, Model 150-1
44-278	22	Ridge Forming Disc used with foot 405-419 on knit material, Model 150-1
44-287	*	Ridge Forming Disc for Padding on Heavy Material, Model 150-1
44-291	13, 23	Ridge Forming Disc for Book Seams, Model 150-9
44-294	*	Disc in 444-294 Model 150-23. Extra Light Work
44-296	22	Ridge Forming Disc (Beaded) Model 150-5, use with retainer 137-141
45-345	11	Handle Lever to adjust supplementary Ridge Forming Disc for through stitch Model 150-6TS
45-351	*	Link Motion Feed Lever
45-352	4, 5, 6	Lever for oscillating Ridge Forming Disc in base of Arm

PARTS LIST FOR LEWIS CLASS 150 MACHINES

<u>Part No.</u>	<u>Plate</u>	<u>Description</u>
45-357	18, 20, 21	Fork Lever for shogging ridge forming disc in arm, Model 150-23
45-403	15	Feed Lever in head, Model 150-16, 150-20
45-429	20	Lever for oscillating ridge forming disc, in base of arm, Model 150-23
45-457	*	Nipper Rod Lever
46-148	7	Link for spring 21-344 in base of arm
46-155	15	Drive-Link for knives under head, Model 150-16, 150-20
46-157	15, 16, 24	Plunger Link, Model 150-16, 150-20
46-164	5, 6, 9	Link connecting crank 48-150 to crank 48-127 in base of arm
47-119	18, 19, 20, 21	Connecting Rod for shogging ridge forming disc in base of arm, Model 150-23
48-105	3	Crank for driving needle shaft in head
48-127	4, 5, 6, 9	Crank on shaft 14-429 for depressing feed plates in cylinder base
48-138	19, 20, 21	Crank on shaft 14-440 on base of arm for shogging ridge forming disc, Model 150-23
48-141	15, 17	Crank for driving lower knives, Model 150-16, 150-20
48-150	4, 6, 9	Crank on shaft 14-400 to depress feed plates and roll back ridge forming disc in base of arm
48-151	20	Crank on shaft 14-400 to depress feed plates and roll back ridge forming disc, Model 150-23
50-88	*	Presser Foot Bracket for Model 150-17
50-160	3, 17	Bracket for both sides of presser feet on head
50-210	4, 7	Bracket on end of cylinder base for feed plate holder
50-211	8	Bracket for swing work table 404-126
50-222	4, 6, 7	Bracket fastened to bottom of cylinder base
50-223	13, 14	Bracket on presser foot for folders, Models 150-9 and 150-15
50-227	20	Bracket for large work table 404-114
50-233	15, 16, 17	Bracket on end of cylinder base for feed plate holder, Model 150-16, 150-20
50-234	15, 17	Bracket attached to cylinder base for belt loop knives, Model 150-16, 150-20
50-280 L	13	Bracket for folder adjusting screw
50-281	*	Nipper Rod Guide Bracket, screw FP539

PARTS LIST FOR LEWIS CLASS 150 MACHINES

<u>Part No.</u>	<u>Plate</u>	<u>Description</u>
51-14	8	Latch for Swing Work Table 404-126
51-21	9	Latch for Locking Disc Mechanism
57-17	2	Hand Wheel
62-21	21	Oil Cup for Shaft 14-441 in Arm, Model 150-23
62-25	2, 6	Oil Cup for Connecting Rod 447-118 and 447-125 in Arm
63-29	17, 24	Felt Oil Pads between Lower Knives, Model 150-16, 3/8"; Model 150-20, 5/16"
63-30	17, 24	Felt Oil Pads between Lower Knives for 5/16" Belt Loops, Model 150-16
63-33	17	Felt Oil Pads between Lower Knives, Model 150-20, 3/8"
68-21	*	Thread Tension Staff
70-28	6	Sleeve for connecting Knee Press Rod to Shaft 14-400 in Base of Arm
70-52	6	Bearing Sleeve Bushing in Connecting Rod 447-118 in Arm
70-53	2	Sleeve in Head for adjusting Looper Ball Joint 4124-27
70-54	6	Sleeve on Shaft 14-400 to locate Lever 48-150 in Base of Arm
70-55	19, 21	Sleeve for Crank 448-137 in Cylinder Base, Model 150-23
70-72	*	Automatic Tension Staff Sleeve
71-87	6	Rod for Knee Press 4129-18
71-88	15	Connecting Rod only for operating knives under Head. Model 150-16, 150-20
71-105	*	Nipper Rod
75-153	25	Edge Guide for Presser Feet 405-409-1 405-522, 405-514, 405-558, Models 150-7, 150-23
75-210	22	Edge Guide for Presser Foot 405-419 and 405-529
75-212	*	Edge Guide on Cylinder Base for Pants Bottoms, Model 150-5. Screw 18-750
75-215	22	Edge Guide for Presser Feet 405-393-2 405-394-4, 405-394-5, 405-494-8, 405-395-1, Models 150-1 and 150-5

PARTS LIST FOR LEWIS CLASS 150 MACHINES

<u>Part No.</u>	<u>Plate</u>	<u>Description</u>
76-12	5	Handle of Regulator 149-28 for adjusting Ridge Forming Disc on top Cylinder Base
79-9	5, 15	Ball Stud for 447-23, 4124-51 and 4124-56, Sold in 447-23, 4124-51, and 4124-56
79-28	3	Ball Stud in 447-97-1 Ball Joint for oscillating Needle Shaft in Head
79-31	2, 5	Ball in stitch adjusting Regulator 149-16 in Head, and in penetration dial in Base
79-35	19, 20, 21	Ball Stud for Ball Joint 4124-55 in Cylinder Base, Model 150-23 (2) used
97-17	5, 9	Cover Plate on top of Cylinder Base
99-304	12, 19, 21, 25	Holder, Yielding, for Ridge Forming Disc Plunger 26-152 in Cylinder Base
107-44	5	Flange for Driving Ridge Forming Disc on shaft 14-394 in Cylinder Base
107-51	4, 5	Flange for Ridge Forming Disc regulator 149-28 on top of Cylinder Base
110-224	4, 5	More-or-less Dial for Ridge Forming Disc regulator on top of Cylinder Base
110-227	11	Swing cover Plate for 32-208 on end of Cylinder Base, Model 150-6TS
110-230	23	Roll Forming Plate on bottom of 405-502 Presser Feet for Roll Padding, Models 150-6 and 150-6TS
110-234	17, 24	Spacing Plate for Lower Knives, Model 150-16, 3/8"; Model 150-20, 5/16"
110-236	17, 24	Cover Plate for top of Bracket 50-234, Model 150-16, 3/8"; Model 150-20, 5/16"
110-237	17, 24	Cover Plate for top of Bracket 50-234, 5/16" Belt Loops. Model 150-16
110-238	17, 24	Spacing Plate for Lower Knives, 5/16" Belt Loops, Model 150-16
110-285	16, 24	Spacing Plate for top Knives, Model 150-16, 3/8"; Model 150-20, 5/16"
110-286	16, 24	Spacing plate for top Knives for 5/16" wide Belt Loops. Model 150-16
110-293	24	Supporting Plate for Oil Pads, Model 150-16, 3/8"; Model 150-20, 5/16"

PARTS LIST FOR LEWIS CLASS 150 MACHINES

<u>Part No.</u>	<u>Plate</u>	<u>Description</u>
110-294	17, 24	Supporting plate for Oil Pads between Lower Knives 5/16" Belt Loops. Model 150-16
110-295	15, 24	Plates for guiding Belt Loops on bottom of Presser Foot. Model 150-16
110-300	*	Plate for Cylinder Base for Roll Padding, Model 150-6, 150-6TS
110-310	17	Spacing Plate for Lower Knives, Model 150-20, 3/8"
110-311	17	Cover Plate for Bracket 50-234, Model 150-20, 3/8"
110-312	17	Supporting Plate for Felt Oil Pads between Lower Knives, Model 150-20, 3/8"
110-314	16	Spacing Plate for top Knives Model 150-20, 3/8"
115-118	2	Bearing Block for Looper Yoke 449-27 in Head
117-41	5	Pivot Bearing for Cradles 140-11 and 140-12 in Cylinder Base
119-68	15, 16, 24	Top Knives for Belt Loop Machine, Model 150-16, 150-20
119-69	16, 24	Bottom Knives, right hand side for Belt Loop Machine, Model 150-16, 150-20
119-70	15, 16, 24	Bottom Knives, left hand side for Belt Loop Machine, Model 150-16, 150-20
122-35	22, 23, 25	Chaining Finger in Presser Foot, Models 150-1, 150-5, 150-6, 150-6TS, 150-7 and 150-17
122-37	*	Chaining Finger on Presser Foot 405-497, Model 150-15
122-C38	25	Chaining Finger for Presser Foot 405-514, Model 150-23
122-39	22	Chaining Finger for Foot 405-529, Models 150-1, 150-5, and 405-558, Model 150-23
122-43	*	Chaining Finger for 1/4" Bookseam Foot 405-537, Model 150-9
125-23	4	Oil Cap
126-36	25	Crown on Presser Feet, Model 150-7
126-43	25	Crown on Presser Feet, Model 150-23

PARTS LIST FOR LEWIS CLASS 150 MACHINES

<u>Part No.</u>	<u>Plate</u>	<u>Description</u>
130-9	8	Chain for Foot Treadle 4135-9, 150-17
131-C163-1	8	Hooks for Foot Treadle Chain
137-19	2	Oil wick Retainer without hole
137-20	*	Oil wick Retainer with hole
137-54	22	Retainer for Knit Goods Foot 405-419
137-77	25	Cloth Retainer for Presser Feet 405-514 and 405-558, Model 150-23
137-123	22	Cloth Retainer for Padding Foot 405-508, Model 150-1. Use with Ridge Forming Disc 44-277
137-131	24	Cloth Retainer for medium and heavy work on Presser Foot 405-518 for Model 150-16
137-132	22	Cloth Retainer for Feet 405-393-2, 405-394-4, 405-395-1 and 405-529, Models 150-1 and 150-5, and Foot 405-502, Models 150-6 and 150-6TS
137-139	24	Cloth Retainer for light and medium work on Presser Foot 405-517 for Model 150-16
137-141	22	Cloth Retainer for Foot 405-394-8, Model 150-5, used with Ridge Forming Disc 44-296
139-10	2, 4	Counterweight graduated for stitch lengths on Main Shaft in Arm
140-11	5	Yielding Cradle for Ridge Forming Disc Shaft in Cylinder Base, Models 150-1, 150-5, 150-6, 150-6TS, 150-7, 150-9, 150-15, 150-16, 150-17
140-12	19, 20, 21	Yielding Cradle for Ridge Forming Disc Shaft in Cylinder Base, Model 150-23
144-26	8	Felt Pad for Sewing Machine Table
144-28	*	Work Apron Isolator, for 150-7
149-16	2	Regulator for adjusting length of stitch on Main Shaft, in Head
149-28	4, 5	Regulator for adjusting ridge forming Disc on top of Cylinder Base
155-9	4	Indicator for setting length of stitch to figures on 139-10 in arm

PARTS LIST FOR LEWIS CLASS 150 MACHINE

<u>Part No.</u>	<u>Plate</u>	<u>Description</u>
158-13	15, 17	Slide Plate for lower Knife, left hand side, Model 150-16, 150-20
158-14	17	Slide Plate for lower Knife, right hand side, Model 150-16, 150-20
164-9	22	Shim for adjusting height of Cloth Retainer Stop on Presser Feet
652-16	*	Washer for 18-939
666-170	*	Oil Wick for 17-149, also 447-97-1
SB15	3	Set Screws for Collar 439-7 in Head
LS75	3	Spring for stitch adjusting Plunger 426-47 in Head
CS231	4, 5	Nut for Cradle Spring Pin 22-271
LS314	3	Screw for Thread Guides 41-48, 41-49
CS317	21	Set Screw for Bushing 16-255 in Arm for Model 150-23
CS320 1/2	8	Screws for Bracket 50-211 for Work Table 404-126
CS327	3	Screws for Holding Presser Foot Bracket 50-160 on Head, (4) used
LS330	25	Set Screw for Locking Studs 17-111 and 17-113 in Presser Feet, Models 150-7, 150-23
CS331	4, 9	Clamp Screw for Crank 48-127 in Base of Arm and for holding Main Shaft Bushing in Arm and Clamping Belt Guard 8-89
CS335	25	Screw for 126-36 in Presser Feet 405-409-1, 405-522, Model 150-7
CS337	15, 17, 24	Screws for lower knives, Model 150-16, 150-20
CS462	21	Collar for Cam 34-48, Model 150-23
FP505	13, 16	Screw for Cover 32-229 on bottom of Bracket 50-234, Model 150-9, 150-16
FP528	4, 16, 19	Nuts for Feed Plate Screws 18-918 in Cylinder Base
FP539	2, 4, 5, 7, 8, 15, 16, 17, 24	Screw for Brackets 50-210, 50-233 on end of Cylinder Base, also for Clamp Screw in Bearing Block for Looper Yoke 115-118 in Head, and for attaching Folders on Models 150-9, 150-15, 150-16
782 L	15, 17	Screw for Crank 48-141 for driving lower knives, Model 150-16
810 L	3	Screw for Needle Clamp
865 L	5	Bearing Screw for Ball Joint 4124-51 in Cylinder Base

PARTS LIST FOR LEWIS CLASS 150 MACHINES

<u>Part No.</u>	<u>Plate</u>	<u>Description</u>
869 L	15	Nut (left hand thread) for ball Joint connecting Rod under Head, Model 150-16, 150-20
876 L	2	Screw for Holding Presser Foot to Head
1003 L	4, 5	Set Screw for Pivot Bearing Screw 18-869, for Stop Pin 42-25 and (2) for Collar 39-105
1005 L	2, 4	Set Screw for (2) 433-144 also (2) for Lever 45-352 in Cylinder Base and for Counterweight 139-10 in Arm
1009 L	20	Nut for Connecting Rod Shoulder Screw 18-943 in Base of Arm, Model 150-23
1012 L	4, 15, 17	Nut for Ball Screw 79-9 in Cylinder Base
1022 L	4, 5, 16, 17, 21, 22, 24, 25	Set Screw for Collars 39-95, 39-118, 1284 L, and CS462 and in Presser Feet 405-394-4, 405-394-8, 405-502, 405-419, 405-395-1, 405-508, 405-518, 405-529, 405-514 and 405-558
1025 L	2, 4, 8, 9	Set Screw for Gear 27-166 in Cylinder Base, (2) for Collar 39-92 in Arm, for 1388 L and (2) for Work Table 404-126
1029 L	4, 20, 21	Set Screw for Gear 27-166 in Cylinder Base and (2) for Gear 27-76 in Arm, Model 150-23
1031 L	2, 4	Spot Screw for Counterweight 139-10 on Main Shaft in Arm
1055 L	9	Pin for Spring 21-274 in Base
1081 L	3	Screw in Head for holding stitch adjuster, 426-47
1132 L	3, 10, 11	Spring for adjusting thread tension on top of Head
1158 L	4, 5, 16, 19, 20, 21	Clamp Screw for Crank 448-131 and 448-137 in Cylinder Base
1160 L	3, 4, 11 20, 21	Nut for Thread Guide 41-42 on Top of Head, for Bearing Stud 865 L for 4124-51 in Cylinder Base, for Screw 1220 L, Model 150-6TS, for Ball stud 79-35, Model 15-23
1170 L	3	Clamp Screws for Ball Cap on Looper Ball Joint 4124-27 in Head, & for looper
1180 L	4	Shoulder Bearing Screw for Roll 35-21 in Cylinder Base
1183 L	3	Disc for thread tension on top of Head
1192 L	2	Screws for Hand Wheel 57-17
1195 L	2	Set Screw for Main Shaft Bushing 16-196 in Arm

PARTS LIST FOR LEWIS CLASS 150 MACHINES

<u>Part No.</u>	<u>Plate</u>	<u>Description</u>
1197 L	2, 21	Set Screws for bushing 16-255 in base of arm, Model 150-23, and for 16-317
1213 L	2, 3	Clamp Screw for looper ball joint 4124-27 in Head
1220 L	4, 11	Screw for top cover plate and plate 110-227
1221 L	4, 11	Washer for screw 1220 L
1235 L	8, 21	Screw for clamping springs 21-250 and 21-251 to bracket 50-211 on swing work table 404-126, and for attaching gear 27-215 to cam 34-48, Model 150-23
1243 L	3	Screw in needle driving crank 48-105 for clamping eccentric ball 79-28 in Head
1246 L	20	Pin in 27-215 for driving disc shogging cam 34-48, Model 150-23
1284 L	4, 5	Collar on shaft 14-429 in cylinder base
1329 L 1/2	11	Screw for end of shaft 14-435, Model 150-6TS
1333 L	3	Hexagon Head Set Screw for needle drive crank 48-105 in Head
1351 L	22, 25	Screw for edge guides on presser feet
1388 L	9	Collar for eccentric stud 17-157 in base
1442 L	*	Stop Pin, for 1183 L
1673 L	15, 17	Screws to hold trimmer bracket to cylinder base and to hold work plate 4-121 to bracket 50-234, Model 150-16, 150-20
1732 L	13	Knurled Adjusting Screw
1733 L	13	Retaining Spring for 1732 L
22508	6, 8	Screw for 4129-18, for latch 51-14 and 404-126
41355 U	*	Spacer for 18-937, Model 150-9, 150-15, 150-20
61292 H	*	Tension Release Washer
404-114	20	Large Work Table, Models 150-7 and 150-23, complete with brackets 50-227
404-126	8	Swing Work Table when using 32-264 end cover, Models 150-1 and 150-15
404-127	13	Swing Work Table when using 32-264 end cover, Model 150-9
405-393-2	22	Presser Foot complete for light padding and felling, composed of: Foot, 6-56, 16-214, 17-87, 18-270, 18-292, 18-416, 18-623, 18-643, 21-193, 42-24, 75-215, 122-35, 137-132, (4) 164-9, 1022 L, 1351 L, Model 150-1

PARTS LIST FOR LEWIS CLASS 150 MACHINES

<u>Part No.</u>	<u>Plate</u>	<u>Description</u>
405-394-4	22	Presser Foot complete for general padding and felling composed of: Foot, 6-56, 16-214, 17-87, 18-270, 18-292, 18-416, 18-623, 18-643, 21-193, 42-24, 75-215, 122-35, 137-132, (4) 164-9, 1022 L, 1351 L, Standard Foot, Model 150-1
405-394-8	22	Presser Foot complete for light and medium trouser bottoms, composed of: Foot, 6-56, 16-214, 17-87, 18-270, 18-292, 18-416, 18-623, 18-643, 21-193, 42-24, 75-215, 122-35, 137-141, (4) 164-9, 1022 L, 1351 L, Model 150-5
405-395-1	22	Presser Foot complete for heavy padding and felling, composed of: Foot, 6-56, 16-214, 17-87, 18-270, 18-292, 18-416, 18-623, 18-643, 21-193, 42-24, 75-215, 122-35, (4) 164-9, 137-132, 1022 L, 1351 L, Models 150-1 and 150-5
405-409-1	25	Presser Foot complete for Furs, light and medium composed of: Foot, 6-56, 17-113, 18-292, (2) 18-345, 18-643, 18-744, 21-243, 22-9, 75-153, 122-35, 126-36, 1733 L, 1351 L, LS 330 and CS 335, Model 150-7
405-419	22	Presser Foot, complete for Knit Goods, composed of: Foot, 6-56, 16-214, 17-87, 18-270, 18-292, 18-416, 18-623, 18-643, 21-193, 42-24, 75-210, 122-35, 137-54, (4) 164-9, 1022 L and 1351 L, Model 150-1
405-497	23	Presser Foot complete for Rolled Edge composed of Foot, 6-56, 18-292, 18-643, and 122-37, Model 150-15
405-502	23	Presser Foot complete for Roll Padding, composed of, Foot, 6-56, 16-214, 17-87, 18-270, (2) 18-281, 18-292, 18-416, 18-623, 18-643, 21-193, 42-24, 110-230, 122-35, 137-132, 1022 L and (4) 164-9, Model 150-6 and 150-6TS
405-503	23	Presser Foot complete for Padding, composed of Foot, 6-56, 18-292, 18-643, 21-63, 122-35, 4137-126, Model 150-17

PARTS LIST FOR LEWIS CLASS 150 MACHINES

<u>Part No.</u>	<u>Plate</u>	<u>Description</u>
405-508	22	Presser Foot complete for Padding Tropicals and Rayon composed of Foot, 6-56, 16-214, 17-87, 18-270, 18-292, 18-416, 18-623, 18-643, 21-193, 42-13, 122-35, 137-123, and 1022 L, Model 150-1
405-514	25	Presser Foot complete for light and medium Bluff edge work (standard) composed of Foot, 6-56, 16-214, 17-87, 17-111, 18-292, (2) 18-345, 18-416, 18-643, 18-744, 21-240, 21-243, 75-153, 122-C38, 126-43, 137-77, 1022 L, 1351 L, LS 330, Model 150-23
405-517	24	Presser Foot complete for 5/16" Belt Loops light and medium material com- posed of Foot, 6-56, 16-214, 17-87, 18-270, 18-416, 18-643, (4) 18-657, 21-193, (2) 110-295, 137-130 and 1022 L, Model 150-16
405-518	24	Presser Foot complete for 5/16" Belt Loops medium and heavy material com- posed of Foot, 6-56, 16-214, 17-87, 18-270, 18-416, 18-643, (4) 18-657, 21-193, (2) 110-295, 137-131 and 1022 L, Model 150-16
405-522	25	Presser Foot complete for sewing heavy furs composed of Foot 6-56, 17-113, 18-292, (2) 18-345, 18-643, 18-744, 21-243, 22-9, 75-153, 122-35, 126-36, 1351 L, LS 330 and CS 335, Model 150-7
405-529	22	Presser Foot complete for extra heavy bridles, padding and heavy pants bot- toms composed of Foot, 6-56, 16-214, 17-87, 18-270, 18-292, 18-416, 18-623, 18-643, 21-193, 42-24, 75-210, 122-39, 137-132, (4) 164-9, 1022 L and 1351 L, Model 150-1 and 150-5
405-537	23	Presser Foot complete for 1/4" book seam light material composed of Foot, 6-56, 18-292, 18-643, 122-43, Model 150-9
405-538	23	Presser Foot complete for 3/8" book seam light and medium material with seams composed of, Foot, 6-56 and 18-643, Model 150-9

PARTS LIST FOR LEWIS CLASS 150 MACHINES

<u>Part No.</u>	<u>Plate</u>	<u>Description</u>
405-558	25	Presser Foot complete for extra heavy bluff edge work composed of Foot, 6-56, 16-214, 17-87, 17-111, 18-292, (2) 18-345, 18-416, 18-643, 18-744, 21-240, 21-243, 75-153, 122-39, 126-43, 137-77, 1022 L, 1351 L and LS 330, Model 150-23
405-560	*	Presser Foot complete composed of Foot, 6-70, 18-643, Model 150-20
414-449	16, 24	Plunger Shaft complete in Cylinder Base, Models 150-16, 150-20
426-47	3	Stitch adjusting plunger complete on top of Head, composed of 16-194, 20-79, 26-47, LS75
431-147	23	Folder for Extra Light Rolled Edge, No. 00, Model 150-15. Use Spring 21-C269-1
431-148	23	No. 1 Folder for light material for rolled edge, Model 150-15. Use Spring 21-C269-1
431-149	23	No. 2 Folder for rolled edge, medium (Std.), Model 150-15. Use Spring 21-C269
431-150	23	No. 3 Folder for rolled edge, heavy, Model 150-15. Use Spring 21-C269
431-159	23	No. 4 Folder for rolled Edge Extra Heavy, Model 150-15. Use Spring 21-C269
431-169	16, 24	Folder for 5/16" wide belt loop, light to medium material. Model 150-16
431-170	16, 24	Folder for 5/16" wide belt loop, medium to heavy material. Model 150-16
431-171	24	Folder for 3/8" wide belt loop, light to medium material. Model 150-16
431-172	24	Folder for 3/8" wide belt loop, medium to heavy material. Model 150-16
431-L175-3/16	23	Folder for light material, Model 150-9
431-M175-3/16	23	Folder for medium material, Model 150-9
431-175 3/16 H	23	Folder for heavy material, Model 150-9
431-L175-1/4	23	Folder for light material, Model 150-9
431-M175-1/4	23	Folder for medium material, Model 150-9
431-H175-1/4	23	Folder for heavy material, Model 150-9
431-175 5/16 L	23	Folder for light material, Model 150-9
431-175 5/16 M	23	Folder for medium material, Model 150-9
431-175 5/16 H	23	Folder for heavy material, Model 150-9
431-L175-3/8	23	Folder for light material, Model 150-9
431-M175-3/8	23	Folder for medium material, Model 150-9
431-H175-3/8	23	Folder for heavy material, Model 150-9 Use Holder 499-323

PARTS LIST FOR LEWIS CLASS 150 MACHINES

<u>Part No.</u>	<u>Plate</u>	<u>Description</u>
431-M180-3/8	16	Folder for 3/8" wide belt loop, Model 150-20
431-M180-5/16	16	Folder for 5/16" wide belt loop, Model 150-20
433-93	2	Needle Driving Eccentric in Head
433-144	2, 4, 6, 21	Eccentric for oscillating Ridge Forming Disc on Main Shaft in Arm
433-151	4, 6	Eccentric on Shaft 14-458 for Lever 45-352 in Base of Arm
439-7	3	Collar complete with Screws SB15 on Needle Shaft 14-14 in Head
439-C255	13, 14	Collar on Folders. Models 150-9 and 150-15
444-275	12, 18, 21, 25	Ridge Forming Disc (yielding) complete composed of 18-318, (2) 20-122, 21-341, 26-152, 44-275 and 99-304
445-351-1	2, 3	Feed Lever with Oil retainers
446-118	2, 3	Feed Link complete with Screw 18-751
447-23	15	Ball Joint complete, in Head. Models 150-16 and 150-20
447-97-1	2, 3	Ball Connecting Rod complete with Ball 79-28 for driving Needle in Head
447-118	2, 4, 6	Connecting Rod with Sleeve Bushing for oscillating Ridge Forming Disc in Arm
447-125	18, 20, 21	Connecting Rod with Sleeve Bushing for oscillating Ridge Forming Disc in Arm Model 150-23
448-131	4, 5, 16	Crank with Screw 1158 L on Ridge Forming Disc Shaft 14-394 in Cylinder Base
448-135	2	Crank with Bushing 16-321 for driving Looper on Main Shaft in Head
448-139	19, 20, 21	Crank with Screw 18-757 on Lower end of Shaft 14-440 for shogging Ridge Forming Disc, in Base of Arm, Model 150-23
448-171	19, 20, 21	Crank with Screw 1158 L on Ridge Forming Disc Shaft 14-394 for oscillating Disc in Cylinder Base, Model 150-23
449-27	2	Looper Yoke with Screw 18-71 in Head
468-23	3	Tension Staff with Pin Guide on Top of Head
468-23-1	3	Tension Staff complete, composed of 20-60, 1132 L, 1160 L, (2) 1183 L, and 468-23 on top Head
479-8	3	Ball with Screw 18-74 in Looper Ball Joint 4124-27 in Head

PARTS LIST FOR LEWIS CLASS 150 MACHINES

<u>Part No.</u>	<u>Plate</u>	<u>Description</u>
499-297	14	Holder complete with Shaft for Folders, Model 150-15
499-298	5, 13, 14, 16	Holder for Feed Plates, right side, Models 150-1, 150-5, 150-9, 150-15, 150-16, 150-17, 150-20
499-299	10, 11	Holder for Feed Plate in Cylinder Base, Models 150-6 and 150-6TS
499-302	13, 14	Holder for Feed Plate, Left Side, in Cylinder Base, Models, 150-9, 150-15 and 150-20
499-303	12, 18, 19, 21	Holder for Feed Plates in Cylinder base, Models 150-7 and 150-23
499-307	16	Holder for Feed Plate, left side, Model 150-16
499-319	*	Buckram Reel and Holder complete
499-321	13	Holder complete for Folders 431-175, Model 150-9
499-323	*	Holder complete for Folder 431-175-3/8H only, Model 150-9
4118-15	2	Looper Carrier with Screw 1170 L in Head
4118-24	3	Needle Carrier with Screw 18-70 and Pin 22-9, 30-52 and 810 L
4124-27	2, 3	Ball Joint complete with Ball 479-8 for Looper Carrier and screw 1213 L
4124-51	5	Ball Joint complete with Ball 79-9 to connect Link 448-131 to Lever 45-352 in Cylinder Base
4124-55	19, 20, 21	Ball Joint complete with (2) Ball Studs 79-35 to connect Link 448-137 to Lever 45-352 in Cylinder Base, Model 150-23
4124-56	15, 17	Ball Joint complete with Ball Stud 79-9, connecting Link 46-155 to connecting Rod 71-88, Model 150-16, 150-20
4129-18	6	Knee Press Pad, with screw 22508
4135-9	8	Foot Treadle complete with Spring, Bracket and Hinge Pin, Model 150-17
4137-126	23	Cloth retainer complete with thread breaking finger on Foot 405-503, Model 150-17
4137-149	*	Tension Disc Retainer, complete includes 137-149 and 1726 L

MODEL 150-1

The Model 150-1 is a general utility machine, and will do the following operations:

Felling Edge Tape.
Felling Bridles.
Felling turned up bottom of
full lined coats.
Fell Wiggin in Sleeves.
Tacking Cuffs.
Felling Patches.
Tacking Sleeve Linings to
seams of sleeves.
Padding collars and Lapels.
Tacking facings to canvas.
Felling knit materials.

See General Instructions for Class 150 Machines for setting up and adjusting the Model 150-1 machine.

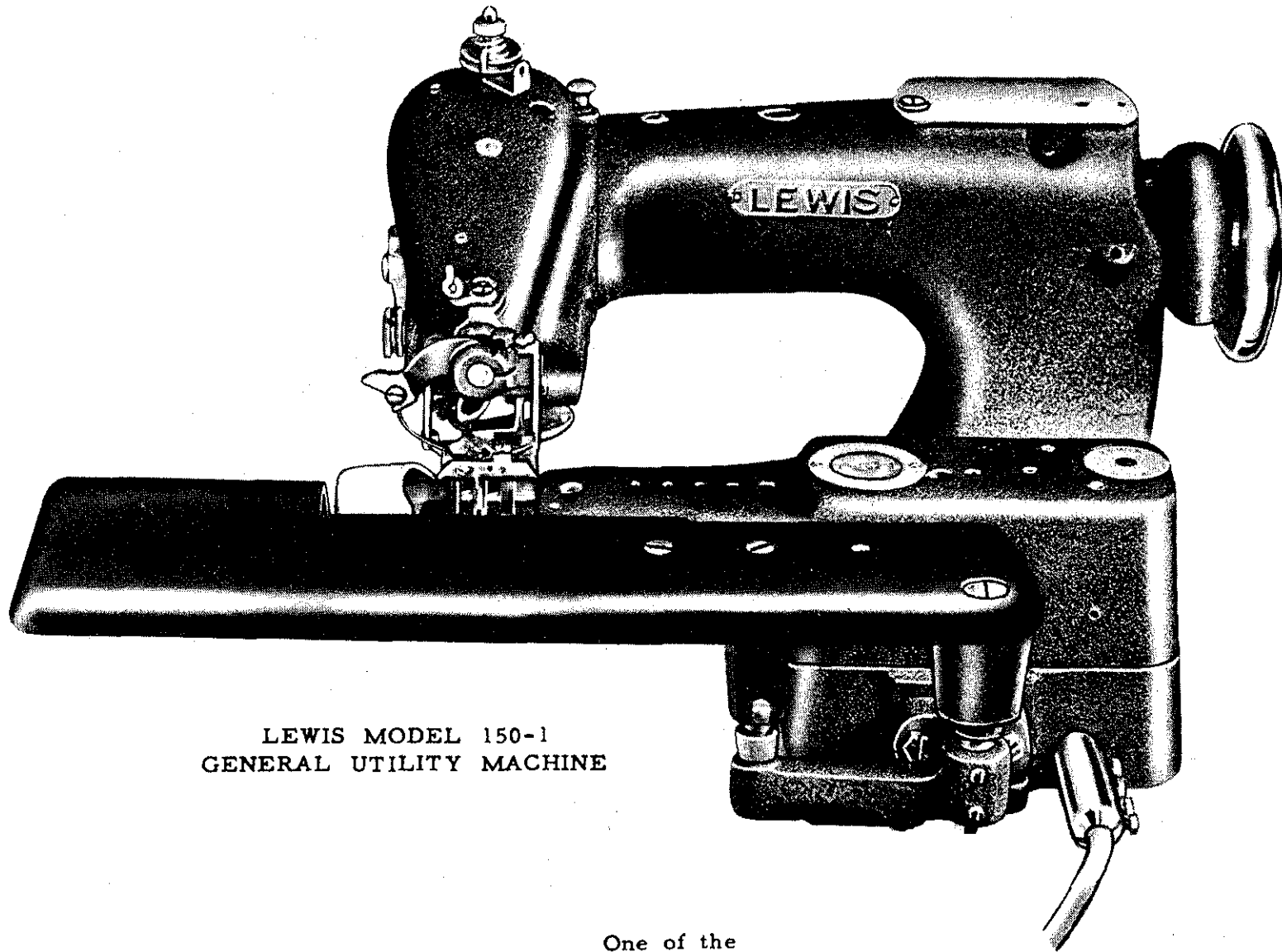

LEWIS MODEL 150-1
GENERAL UTILITY MACHINE

One of the
Lewis Class 150 Single Thread Chain Stitch Sewing Machines

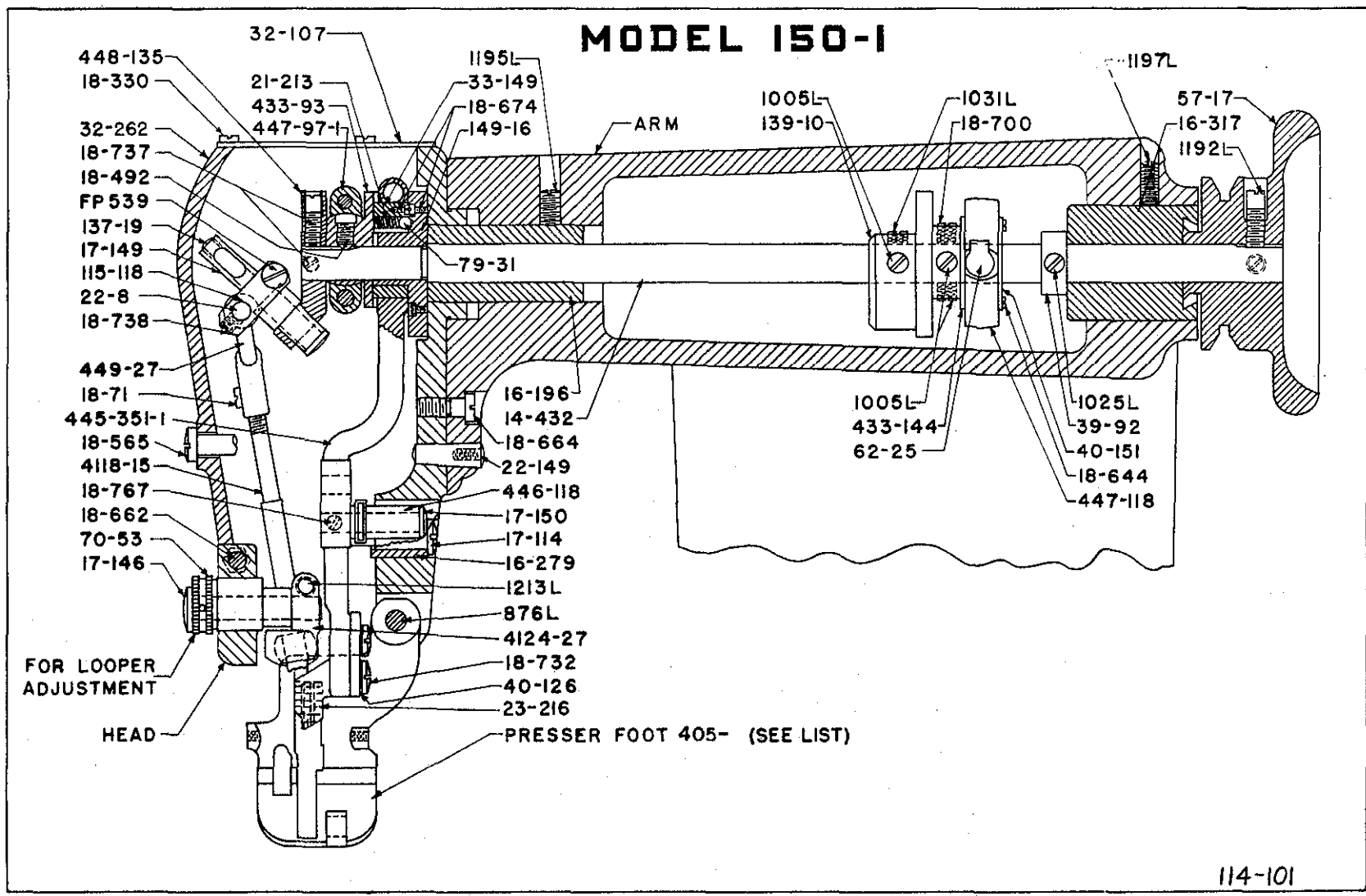

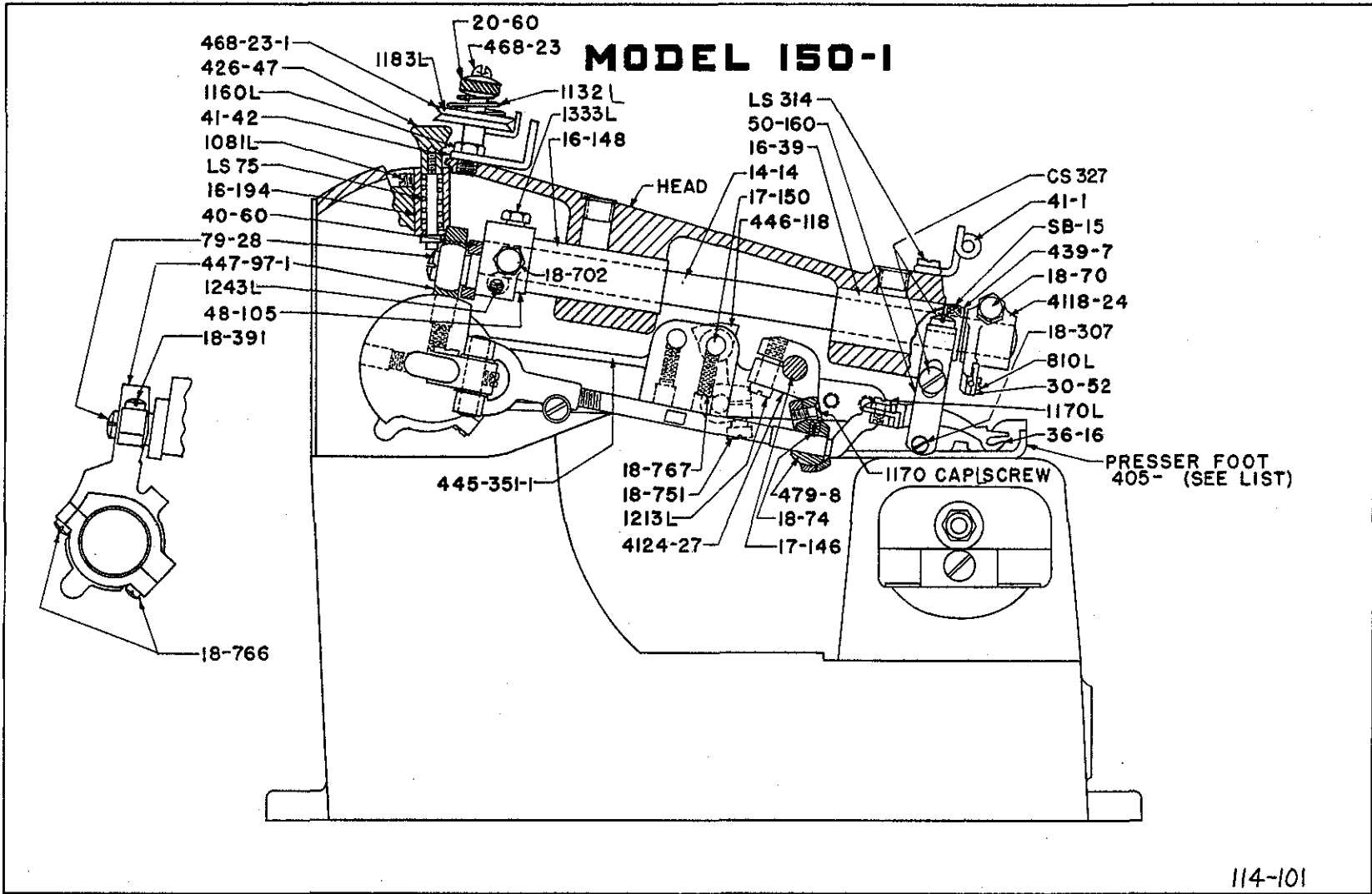
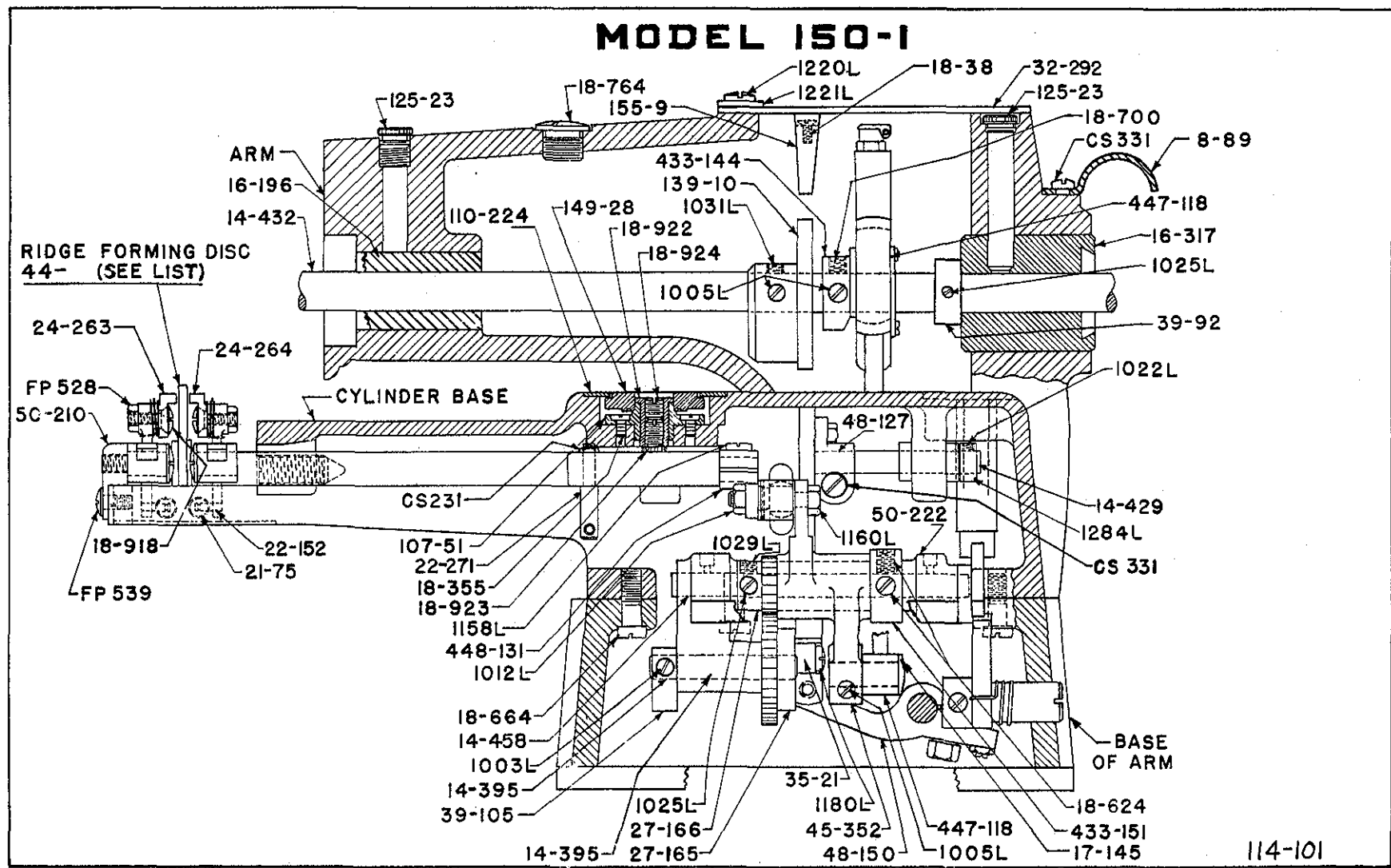

PLATE 3

114-101



MODEL 150-1

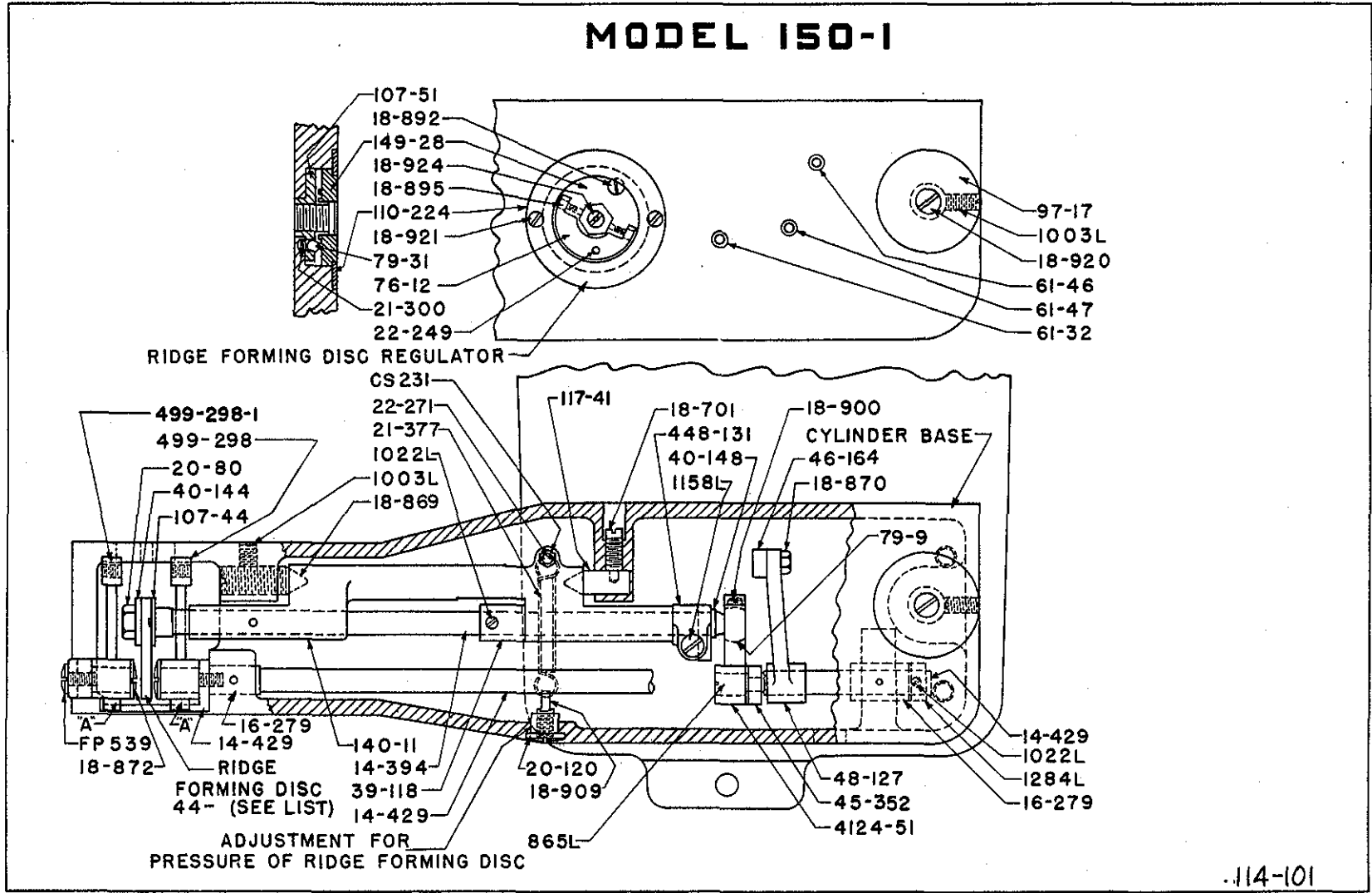

PLATE 5

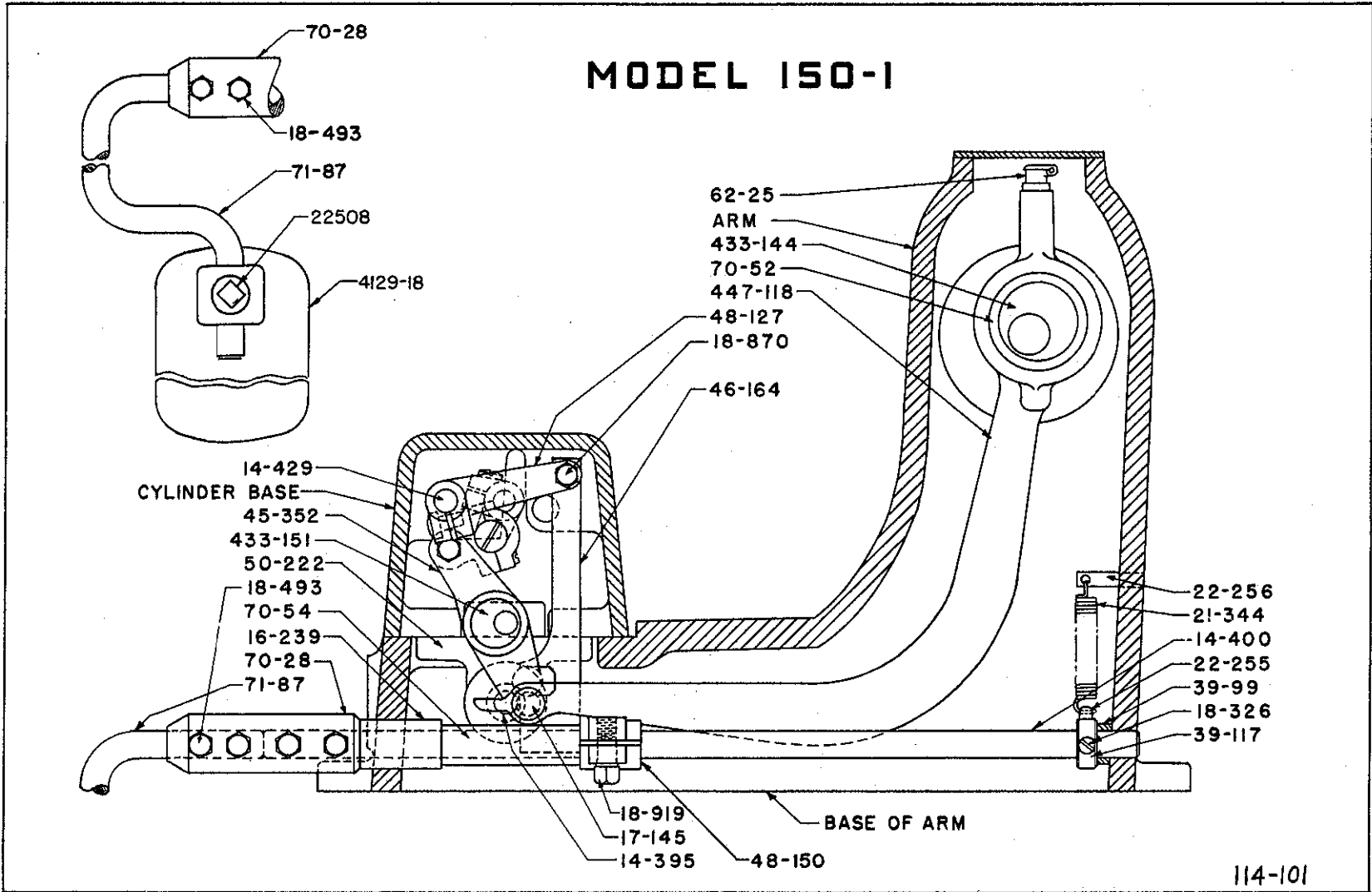

PLATE 6

MODEL 150-1

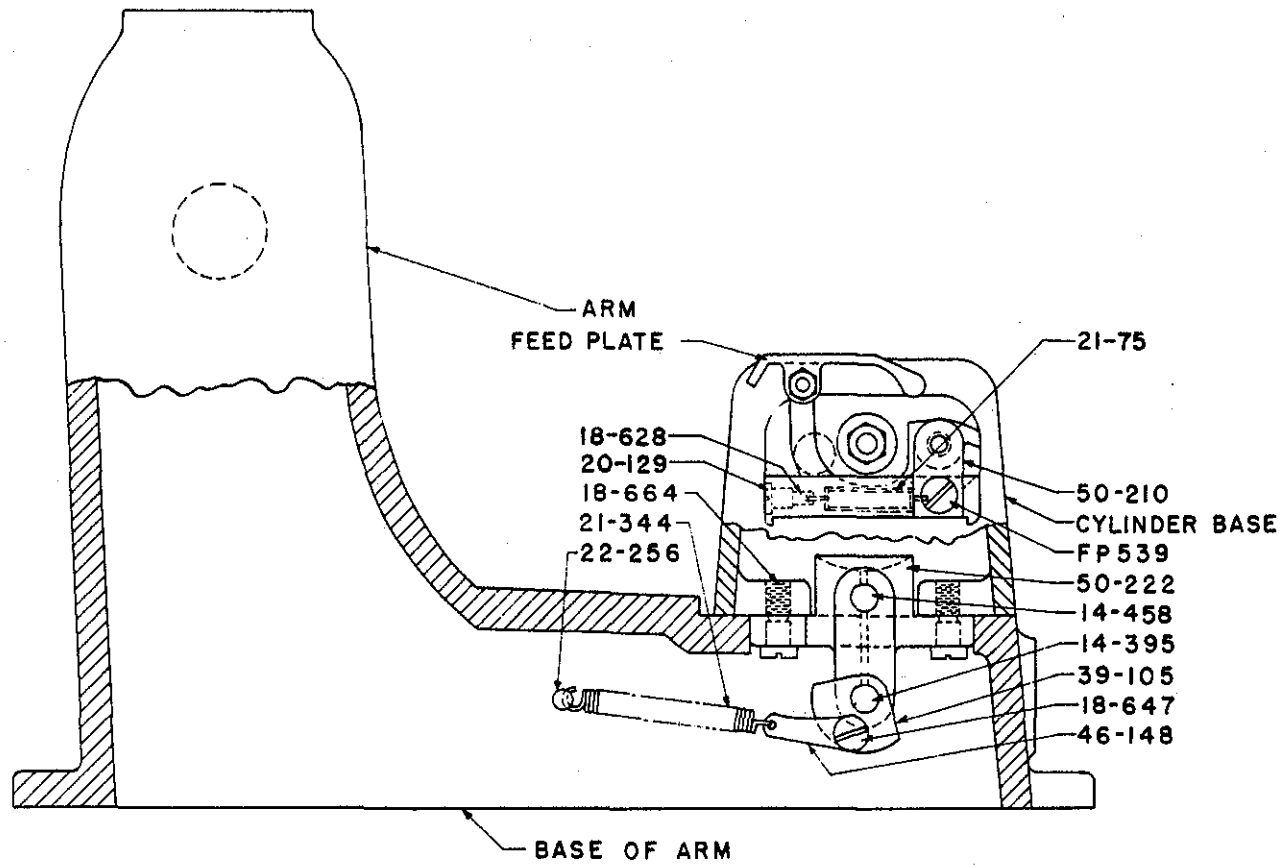

PLATE 7

114-101

PLATE 8

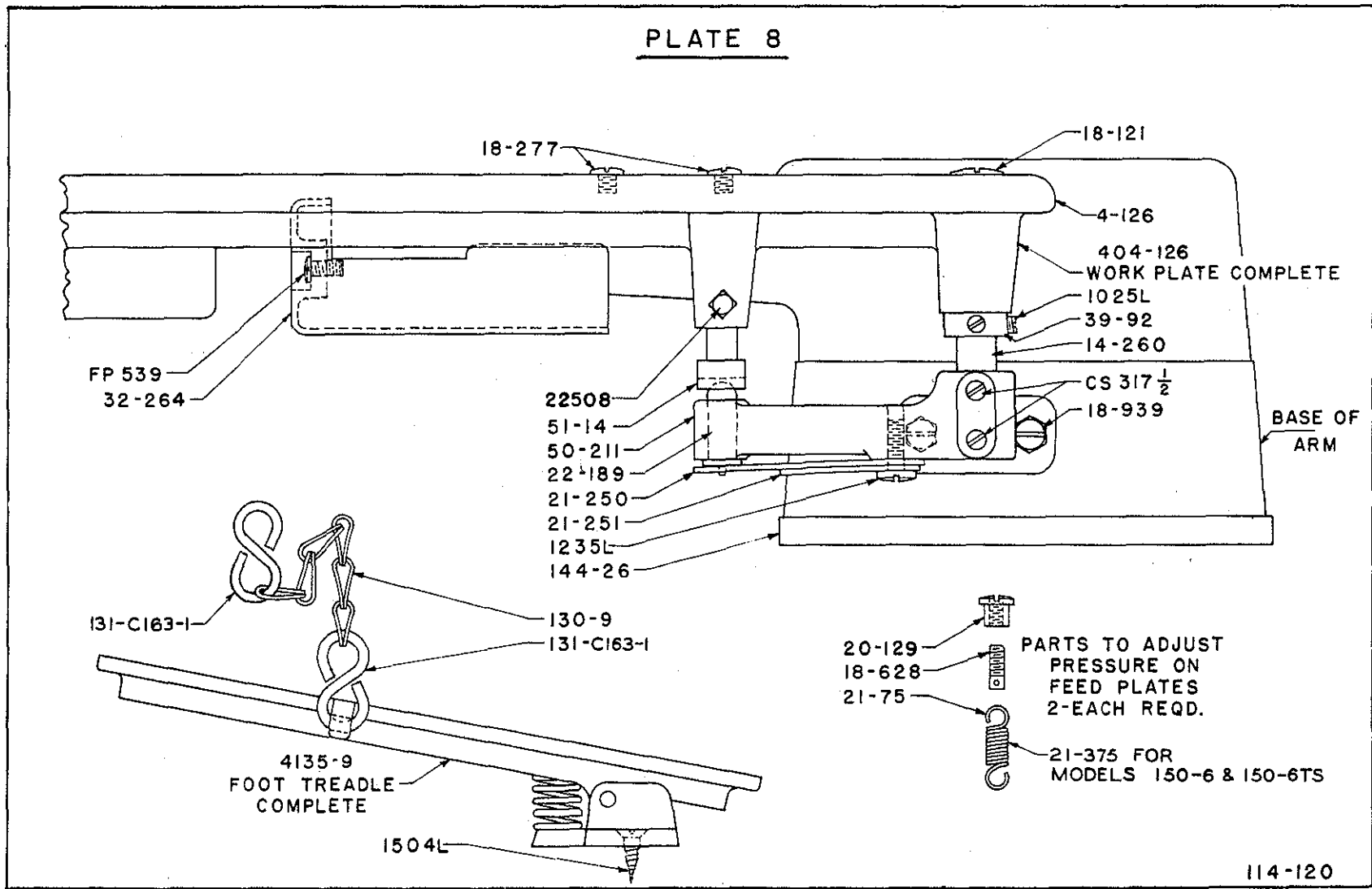
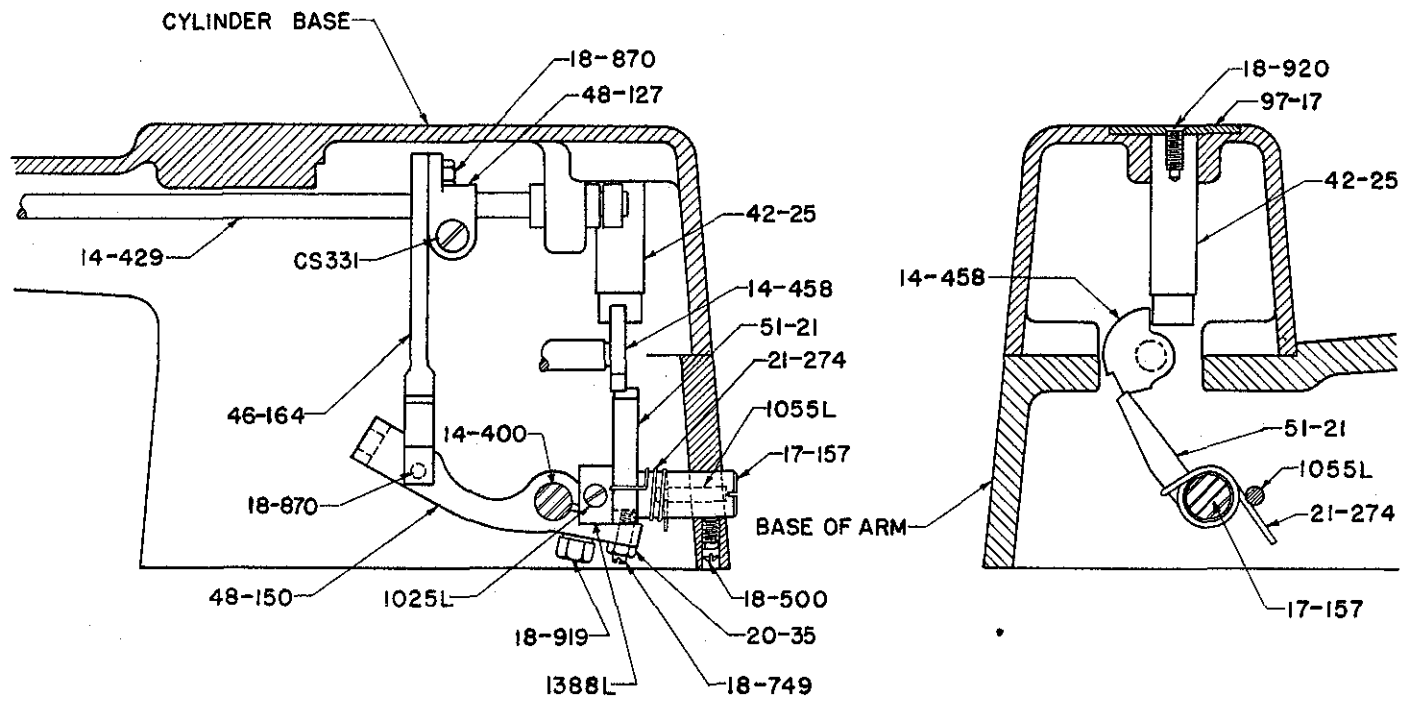

PLATE 8

114-120

MODEL 150-1



114-101

PLATE 9

PARTS LIST FOR LEWIS MODEL 150-1 MACHINES

General Utility Machine
for Padding and Felling

<u>Part No.</u>	<u>Plate</u>	<u>Description</u>
23-216	22	Feed.
24-263	22	Feed Plate (left).
24-264	22	Feed Plate (right).
44-253	22	Standard Ridge Forming Disc for General work - Padding, taping and Felling.
44-277	22	Ridge Forming Disc for tropicals and rayons.
44-278	22	Ridge Forming Disc for hemming knit materials.
44-287	*	Ridge Forming Disc for extra heavy material.
137-54	22	Cloth Retainer for knit goods in presser foot 405-419, use with Disc 44-278.
137-123	22	Cloth Retainer for tropicals and rayon in Presser Foot 405-508, Use with disc 44-277.
137-132	22	Cloth Retainer in Presser Feet 405-393-2, 405-394-4, 405-395-1 and 405-529. Used with Discs 44-253 and 44-287.
405-393-2	22	Presser Foot for Light Weight Material.
405-394-4	22	Presser Foot for Medium Weight Material. (Standard).
405-395-1	22	Presser Foot for Heavy Material.
405-419	22	Presser Foot for Hemming Knit Material.
405-508	22	Presser Foot for Tropicals and Rayon.
405-529	22	Presser Foot for Extra Heavy Material.

The Model 150-1 is the basic model for this catalogue. See Plates 2 to 9, for parts, and general list of parts for descriptions, pages 20 to 43.

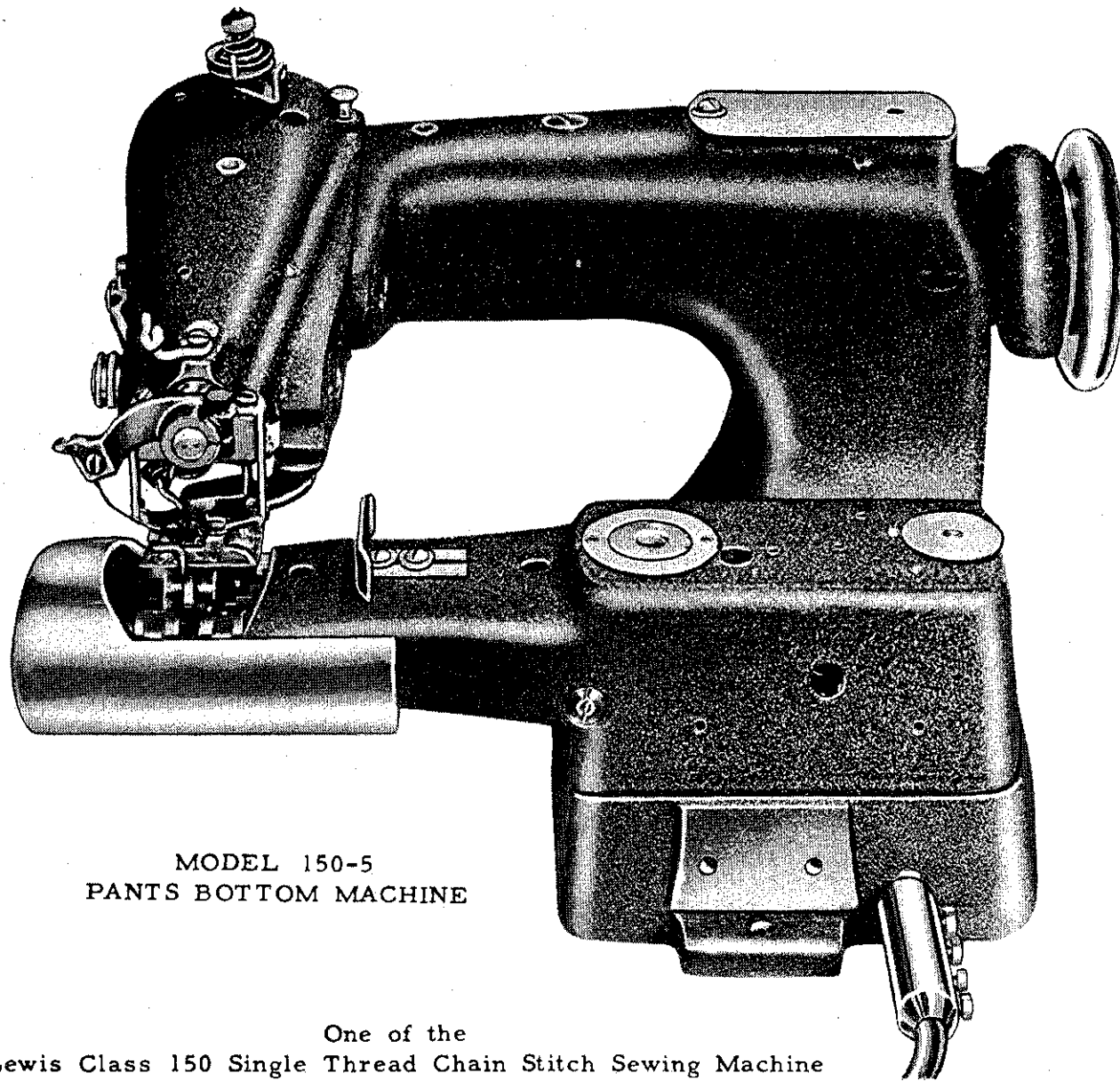

MODEL 150-5
PANTS BOTTOM MACHINE

One of the
Lewis Class 150 Single Thread Chain Stitch Sewing Machine

MODEL 150-5

The Model 150-5 is specially fitted for sewing the bottom of pants.

The Machine has an adjustable guide that may be set for the desired distance to turn up the bottom, and is equipped with a cylindrical end cover for more easily sewing the pants bottom.

The standard setting of the ridge forming disc is .045" from the left side of the opening in the presser foot.

See General Instructions for Class 150 Machines, for setting up and adjusting.

PARTS FOR MODEL 150-5

For Sewing Pants Bottoms

<u>Part No.</u>	<u>Plate</u>	<u>Description</u>
18-750	*	Screw for 75-212
23-216	2, 22, 23, 25	Feed.
32-264	8	End Cover for Cylinder Base.
44-253	22	Ridge Forming Disc for Heavy Pants Bottoms.
44-296	22	Ridge Forming Disc for pants bottoms.
75-212	*	Edge Guide for pants bottoms.
137-132	22	Cloth Retainer in Presser Feet 405-395-1, 405-529. Use with Disc 44-253.
137-141	22	Cloth Retainer in Presser Foot 405-394-8. Use with Disc 44-296.
405-394-8	22	Presser Foot for Light and Medium Work. (Std.)
405-395-1	22	Presser Foot for Heavy Work.
405-529	22	Presser Foot for Extra Heavy Work.

Parts not listed are common to Model 150-1, (See Plates 2 to 9, Pages 46 to 53)

MODEL 150-6 INSTRUCTIONS

The Model 150-6 Machine has been designed to automatically fill in the canvas of collars and lapels to obtain the roll required for the best tailored coats.

The automatic roll in the collar and lapel is produced by filling in a small amount of canvas relative to the body fabric by shaping the work over the ridge forming disc between each row of stitches, therefore, the more rows used, the greater will be the roll.

A reasonably tight tension and stitch must be used and made to hold the small amount of canvas that is filled in, to the cloth between each row of stitches. If a loose stitch is used, there will be no rolled effect to the lapel or collar.

To obtain the best roll for lapels and collars the rows of stitches must be $3/8$ " or less apart, and a reasonably tight stitch must be used.

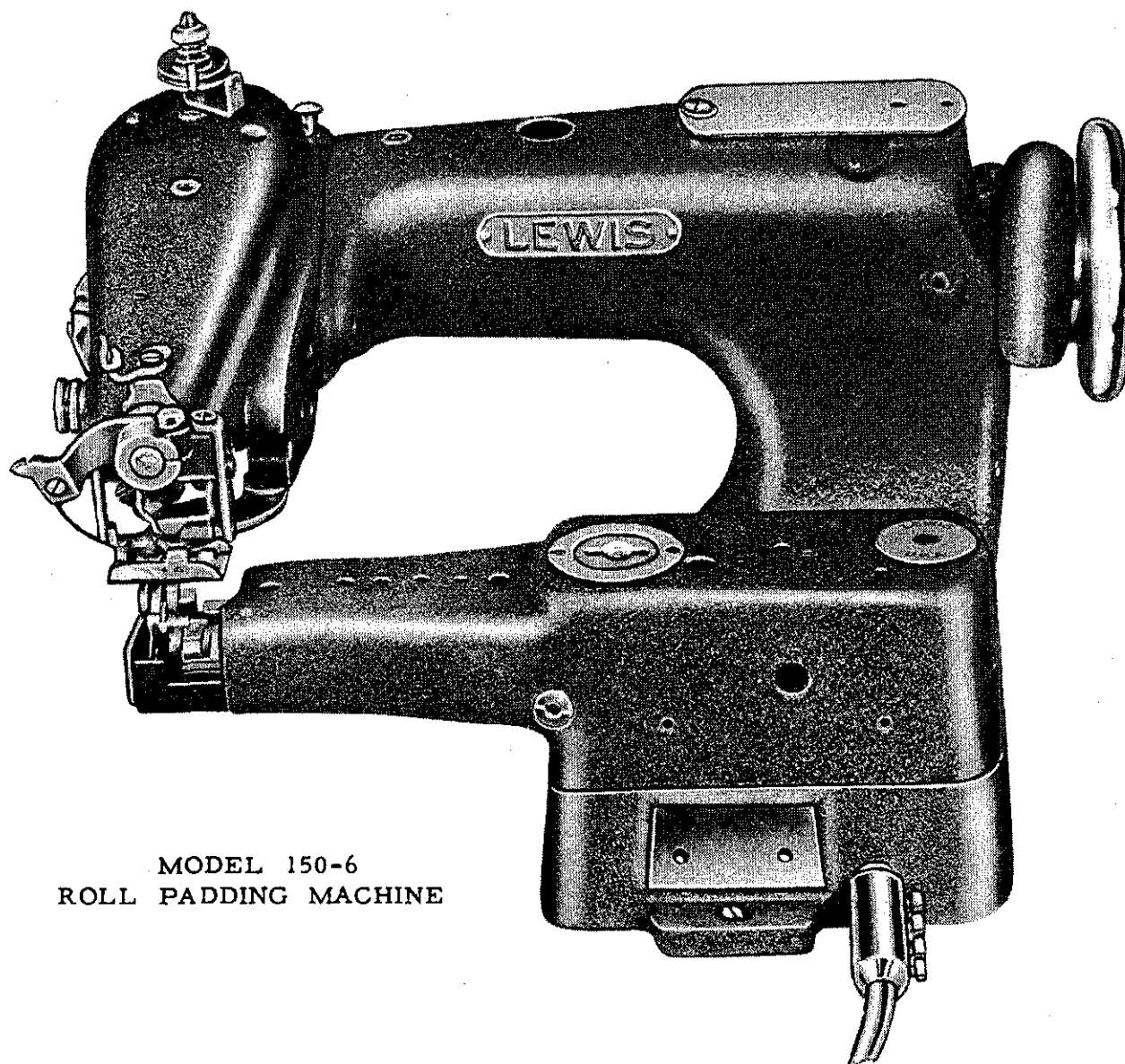

MODEL 150-6
ROLL PADDING MACHINE

One of the
Lewis Class 150 Single Thread Chain Stitch Sewing Machine

MODEL 150-6

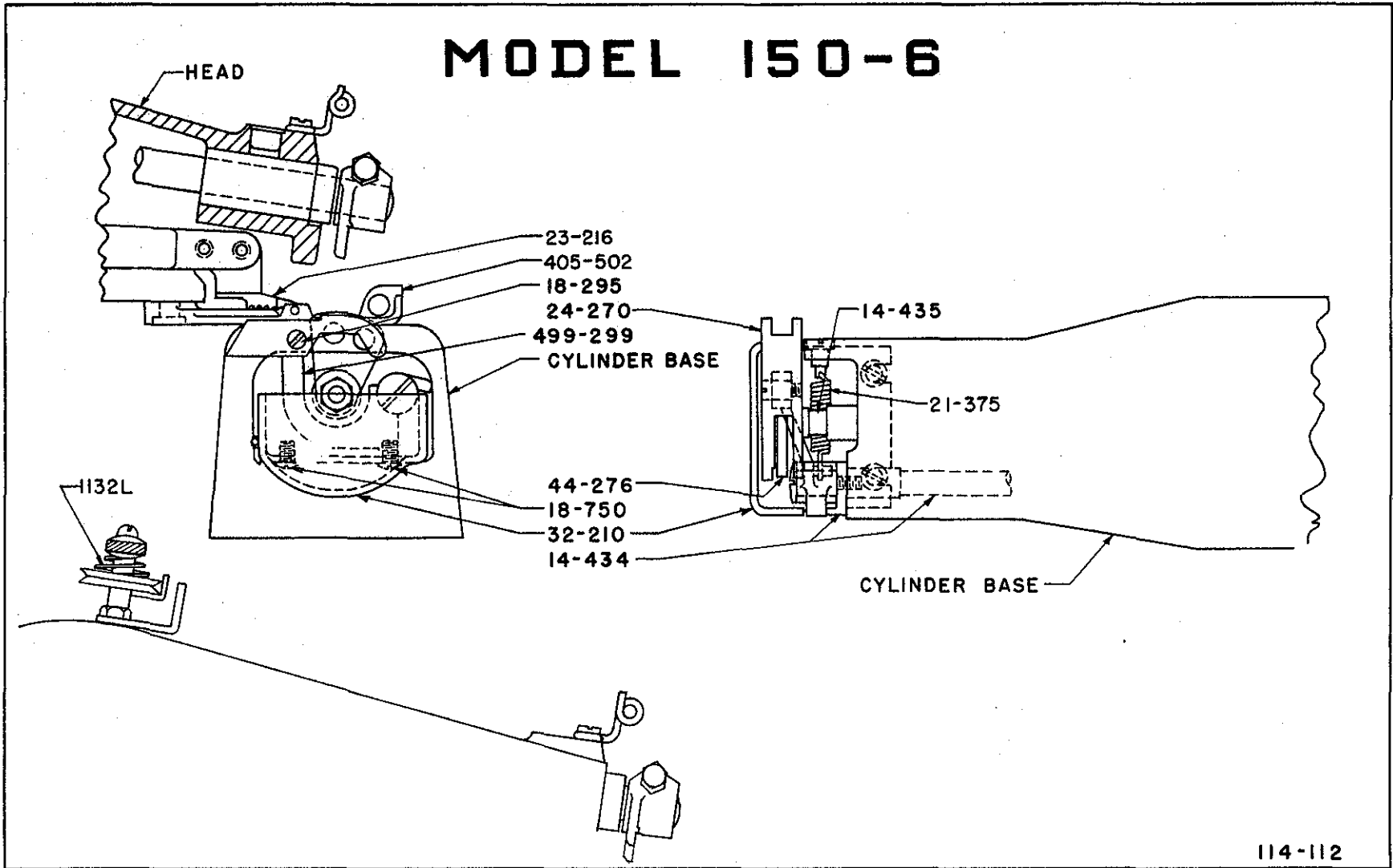

PLATE 10

114-112

PARTS FOR MODEL 150-6

For Rolled Padding

<u>Part No.</u>	<u>Plate</u>	<u>Description</u>
14-394	10	Shaft for Ridge Forming Disc
14-434	10	Shaft in Base for Feed Plate Holders
18-295	10	Bearing Screw for Feed Plate in Cylinder Base
18-750	10	Screws for Cylinder Base Cover, 32-210
21-375	10	Spring (heavy) for Feed Plate Holder
23-216	2, 22, 23, 25	Feed
24-270	23	Feed Plate for Roll Padding
32-210	10	End Cover for Cylinder Base
44-276	23	Ridge Forming Disc for Roll Padding
110-230	23	Plate on Foot for Roll Padding
405-502	22, 23	Presser Foot for Roll Padding light, medium and heavy work composed of Foot, 6-56, 16-214, 17-87, 18-270, (2) 18-281, 18-292, 18-416, 18-623, 18-643, 21-193, 42-24, 110-230, 122-35, 137-132, 1022 L and (4) 164-9
499-299	10	Holder for Feed Plate in Cylinder Base
1132 L	10	Tension spring (heavy) for adjusting thread tension on top of Head

Parts not listed are common to Model 150-1. See Plates 2 to 9, Pages 46 to 53.

MODEL 150-6TS INSTRUCTIONS

The Model 150-6TS Machine has been designed to automatically fill in the canvas of collars and lapels to obtain the roll required for the best tailored coats, also to make canvas coat fronts.

The automatic roll in the collar and lapel is produced by filling in a small amount of canvas relative to the body fabric by shaping the work over the Ridge Forming Disc between each row of stitches, therefore, the more rows used, the greater will be the roll.

A reasonably tight tension and stitch must be used and made to hold the small amount of canvas that is filled in, to the cloth between each row of stitches. If a loose stitch is used, there will be no rolled effect to the lapel or collar.

To obtain the best roll for lapels and collars the rows of stitches must be $3/8$ " or less apart, and a reasonably tight stitch must be used.

Canvas coat fronts requires a through stitch and the Model 150-6TS has been made so that by lifting up on handle lever No. 45-345 (see Plate 11), a supplementary slide in the disc will be moved upwardly and the end of the slide will project above the disc, causing the needle to penetrate through the work.

ADJUSTING DISC

With the ridge forming disc set with the slide in retarded position, and handle lever down, adjust for blind stitching, using ridge forming disc regulator as stated in General Instructions.

The machine can now be changed to through stitching by shifting handle lever No. 45-345, and back to blind stitching without disturbing the setting for the blind stitch operation.

FOR

Roll Padding,
Lapels and Collars

Also by shifting a
handle lever the
machine will sew
canvas coat fronts.

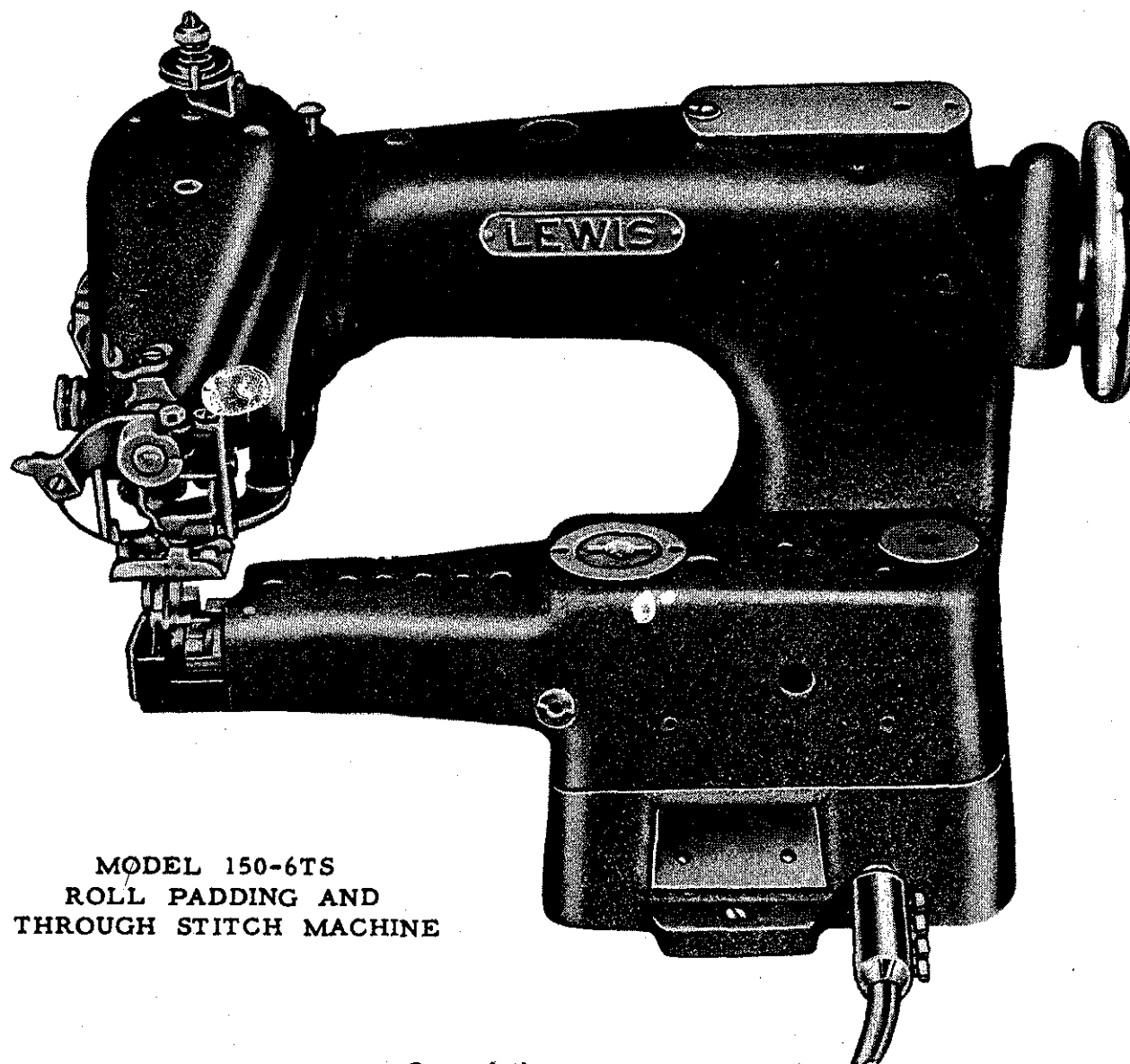

MODEL 150-6TS
ROLL PADDING AND
THROUGH STITCH MACHINE

One of the
Lewis Class 150 Single Thread Chain Stitch Sewing Machine

MODEL 150-6TS

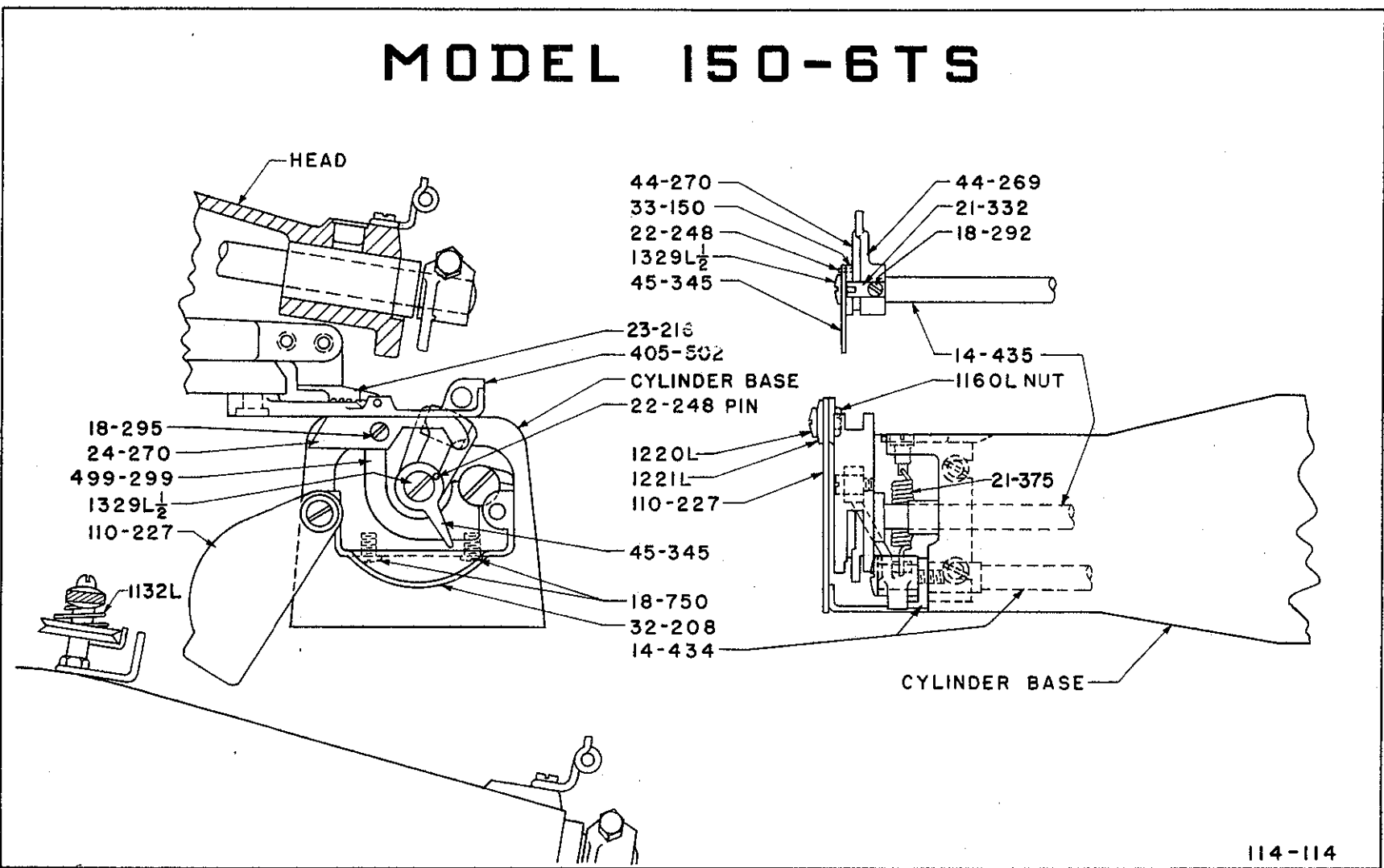

PLATE 11

114-114

PARTS FOR MODEL 150-6TS

Rolled Padding With Through StitchFor Coat Fronts

<u>Part No.</u>	<u>Plate</u>	<u>Description</u>
14-434	11	Shaft in Base for Feed Plate Holders
14-435	11	Shaft for Ridge Forming Disc in Cylinder Base
18-292	22, 23	Screw to hold Spring 21-332 on Disc 44-269
18-295	11	Bearing Screw for Feed Plate in Cylinder Base
18-750	11	Screws for Cover 32-108 in Cylinder Base
21-332	11	Spring on Ridge Forming Disc 44-269 to locate Eccentric 33-150 in Cylinder Base
21-375	11	Spring (heavy) for Feed Plate Holder
22-248	11	Pin in Eccentric 33-150 and Lever handle 45-345 to operate step Ridge Forming Disc
24-270	11, 23	Feed Plate for Roll Padding Models
32-208	11	End Cover for Cylinder Base
33-150	11	Eccentric to adjust supplementary Ridge Forming Disc 44-270 for through stitching
44-269	11, 23	Ridge Forming Disc for through stitch
44-270	11, 23	Supplementary Ridge Forming Disc for through stitch
45-345	11	Handle lever to adjust supplementary Ridge Forming Disc for through stitch
110-227	11	Swing Cover Plate for 32-208 Cover in Cylinder Base
110-230	23	Roll forming plate on bottom of Presser Feet for roll padding
1132 L	11	Tension Spring (heavy) for adjusting thread tension'
1160 L	11	Nut for Screw 1220 L in Cylinder Base
1220 L	11	Screw for Top Cover Plate and for Cover 110-227 in Cylinder Base
1221 L	11	Washer for Screw 1220 L in Cover 110-227 in Cylinder Base
1329 L-1/2	11	Screw for end of Shaft 14-435 in Cylinder Base

Parts not listed are common to Model 150-1. See Plates 2 to 9, Pages 46 to 53.

PARTS FOR MODEL 150-6TS

Rolled Padding With Through Stitch
For Coat Fronts

<u>Part No.</u>	<u>Plate</u>	<u>Description</u>
405-502	23	Presser Foot for Roll Padding, Light, Medium and Heavy Work. Composed of Foot, 6-56, 16-214, 17-87, 18-270, (2) 18-281, 18-292, 18-416, 18-623, 18-643, 21-193, 42-24, 110-230, 122-35, 137-132, (4) 164-9, 1022.
499-299	11	Holder for Feed Plate in Cylinder Base.

Parts not listed are common to Model 150-1, (See
Plates 2 to 9, Pages 46 to 53)

FOR
STAYING FURS
 Felling re-enforcing tape
 along edges.
 Felling tapes and padding
 skins in one operation.
 Stitching backs of fur
 trimmings.

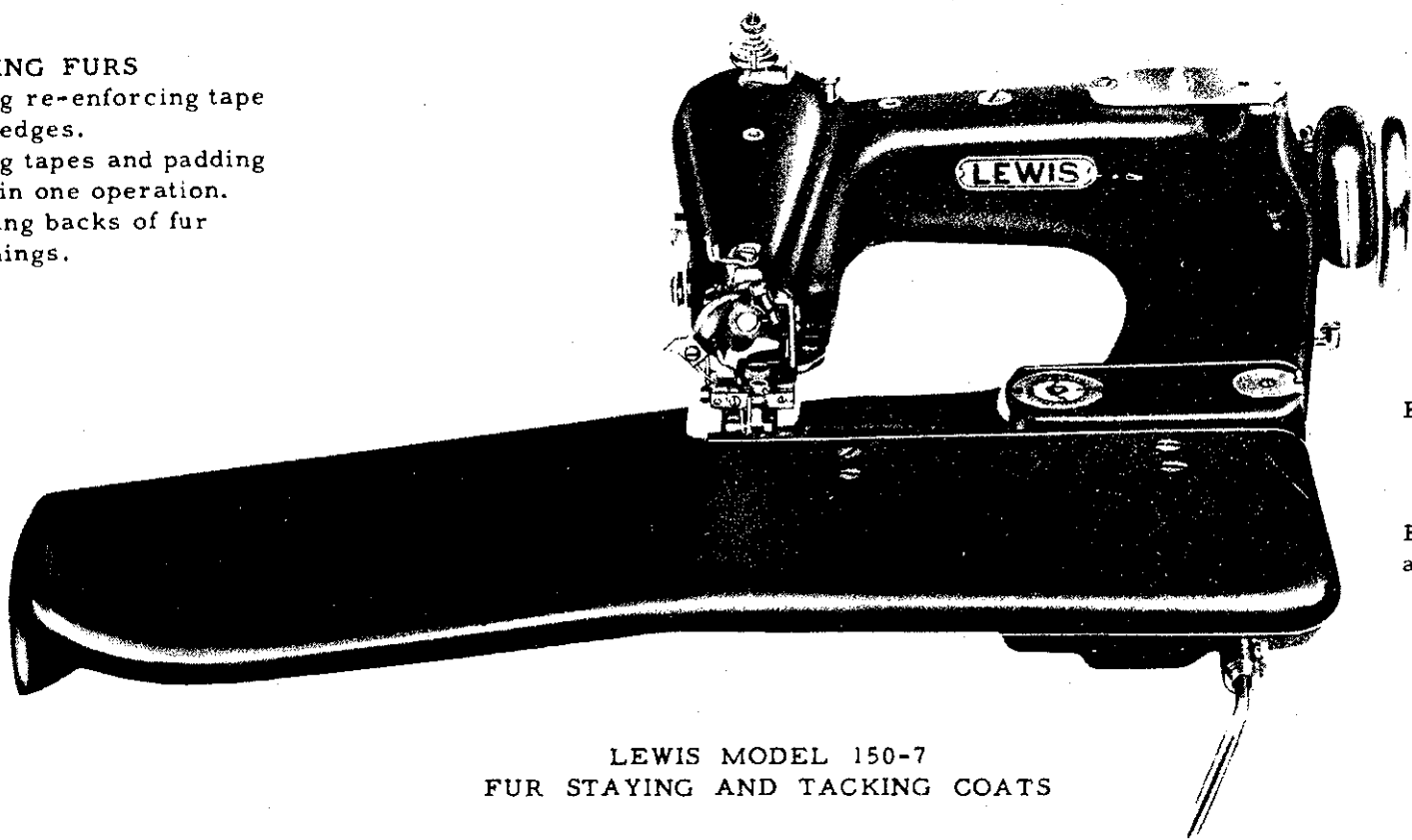

FOR
 Tacking operations
 on coats.

Equipped with
 a crown foot.

LEWIS MODEL 150-7
 FUR STAYING AND TACKING COATS

One of the
 Lewis Class 150 Single Thread Chain Stitch Sewing Machine



MODEL 150-7

The Model 150-7 differs from most class 150 machines, by having a yielding ridge forming disc instead of a rigidly mounted disc to form the node for needle penetration.

The machine was designed to sew furs, and the tacking operation on the inside of coats. It will sew across pockets without sewing the pocket shut, or any other operation where the depth of needle penetration must be all the same from the top, such as:

Staying Furs.

Felling reinforcing tape along edges.

Felling tape and padding skins in one operation.

Stitching backs of fur trimmings.

Tacking operations in coats.

With the yielding ridge forming disc it is possible to regulate the depth of the needle penetration from the top side of the work by using an adjustment mounted on the presser foot, known as a crown.

The crown is positioned directly over the yielding ridge forming disc and the machine can be set so that the needle will penetrate the skin of the furs the desired depth, and regardless of the variation in the skin, or the seams, the needle will always penetrate the same distance from the top of the work, because as the top of the work rubs against the crown, the variation of the thickness of the work causes the disc to yield, and the needle will penetrate always the same distance from the top of the garment, at the place where the garment rubs against the crown.

In the tacking operation on coats the machine can be set for blindstitching a single ply of material, and if two, three or four ply of material passes under the crown, the machine will still sew the top single ply only. For instance, tacking near a pocket, the machine will sew across the pocket without sewing the pocket shut.

MODEL 150-7

ADJUSTING YIELDING DISC

With the crown out of contact with the work, and by using the ridge forming disc regulator, as stated in the "General Instructions" for Class 150 machines, set the machine as for blindstitching. After once set all further adjustments should be made by using the Knurled Headed Crown adjusting screw on the presser foot.

To adjust the crown for more penetration of the needle, turn the adjusting screw in anti-clockwise direction. To adjust the crown for less penetration of the needle turn the adjusting screw in clockwise direction.

See General Instructions for Class 150 machine for setting up and other adjustments for Model 150-7 machine.

MODEL 150-7

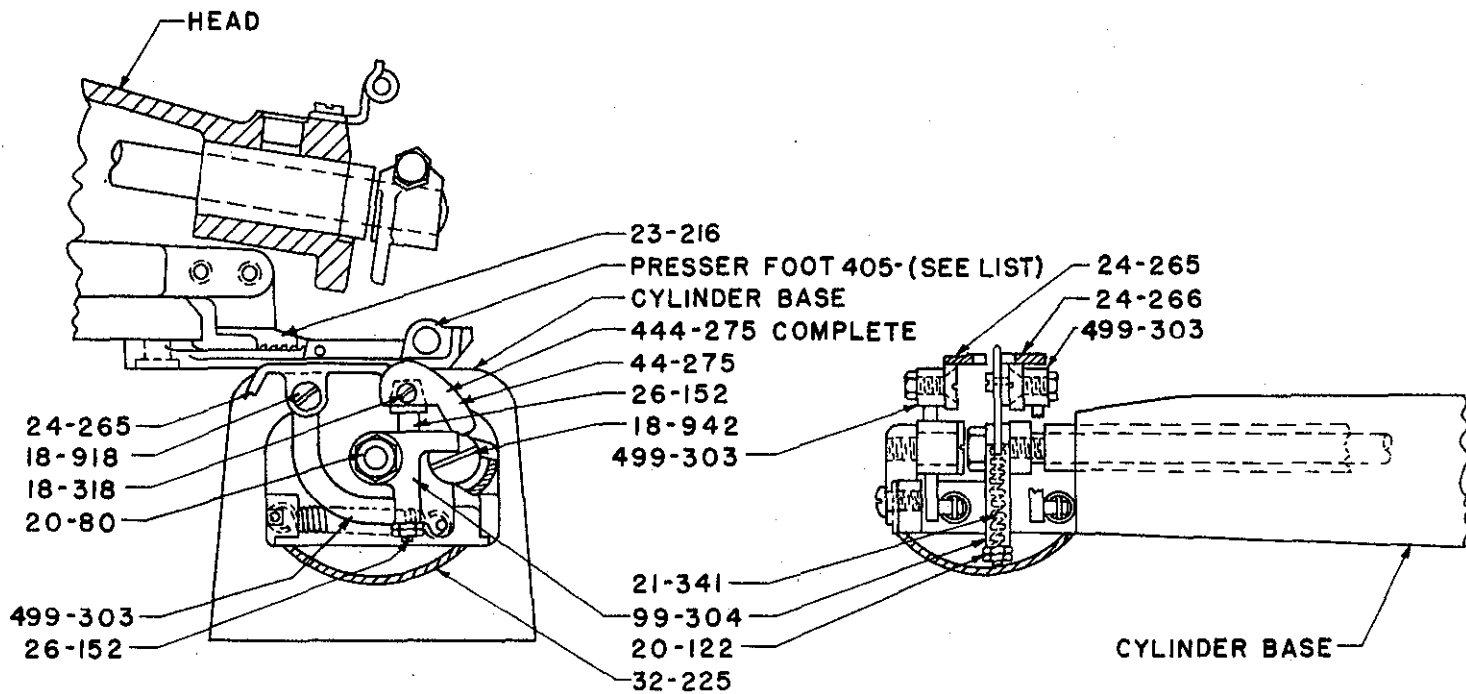

PLATE 12

114-115

PARTS FOR MODEL 150-7

Fur Staying and Coat Tacking

<u>Part No.</u>	<u>Plate</u>	<u>Description</u>
4-C114	20	Work Plate, Large.
17-113	25	Stud for Crown 126-36 on Presser Feet 405-409-1 and 405-522.
18-318	12	Screw for attaching Disc 44-275 to Plunger 26-152 in Cylinder Base.
18-744	25	Knurled Screw for adjusting Crowns on Presser Feet.
18-918	12	Taper Bearing Screws for Feed Plates.
18-942	12	Shoulder Bearing Screw for Feed Plate holders 99-303, Models 150-7 and 150-23.
20-80	12	Nut for locking Ridge Forming Disc on Shaft 14-394 in Cylinder Base.
20-122	12	Nut for Plunger 26-152 in Cylinder Base, Models 150-7 and 150-23.
21-243	25	Spring for adjusting screw on Presser Feet with Crown.
21-341	12	Spring for Plunger 26-152 for Ridge Forming Disc 44-275 in Cylinder Base.
21-357	25	Spring (heavy) for Plunger 26-152.
23-216	12	Feed.
24-265	12	Feed Plate (left).
24-266	12	Feed Plate (right).
26-152	12	Plunger for holding Ridge Forming Disc.
32-225	12	Cover for end of Cylinder Base.
44-275	12,25	Ridge Forming Disc (Yielding) for Fur Staying and Bluff Edge.

Parts not listed are common to Model 150-1. See
Plates 2 to 9, Pages 46-53.

PARTS FOR MODEL 150-7

Fur Staying and Coat Tacking

<u>Part No.</u>	<u>Plate</u>	<u>Description</u>
99-304	12	Holder (yielding) for Ridge Forming Disc Plunger 26-152 in Cylinder Base
122-35	25	Chaining Finger in Presser Foot
126-36	25	Crown on Presser Feet
404-114	20	Large Work Plate Complete for Models 150-7 and 150-23
405-409-1	25	Presser Foot Complete for Furs Light and Medium, composed of Foot, 6-56, 17-113; 18-292, (2) 18-345, 18-643, 18-744, 21-243, 22-9, 75-153, 122-35, 1733 L, 126-36, 1351 L, LS 330 and CS 335
405-522	25	Presser Foot Complete for Sewing Heavy Furs, composed of Foot, 6-56, 17-113, 18-292, (2) 18-345, 18-643, 18-744, 21-243, 22-9, 75-153, 122-35, 126-36, 1351 L, LS 330 and CS 335. Use Plunger Spring 21-357 when using this Foot
444-275	25	Ridge Forming Disc (yielding) complete, composed of 18-318, (2) 20-122, 21-341, 26-152, 44-275 and 99-304
499-303	12	Holder for Feed Plates in Cylinder Base

Parts not listed are common to Model 150-1. See Plates 2 to 9, Pages 46 to 53.

MODEL 150-9

The Model 150-9 is specially fitted for sewing edges of seams in coats, referred to many times as bookseams, and eliminates the need for piping and matching the thread to piping.

The machine is equipped with a folder for turning the edge under, and is equipped with a work plate.

See General Instructions for Class 150 machines for setting up and adjusting the Model 150-9.

Be sure to specify width of seam desired when ordering this model.

The standard setting of the ridge forming disc is .055" from the left side of the opening in the presser foot when machine is using 1/4" folder, and .065" when using 3/8" folder.

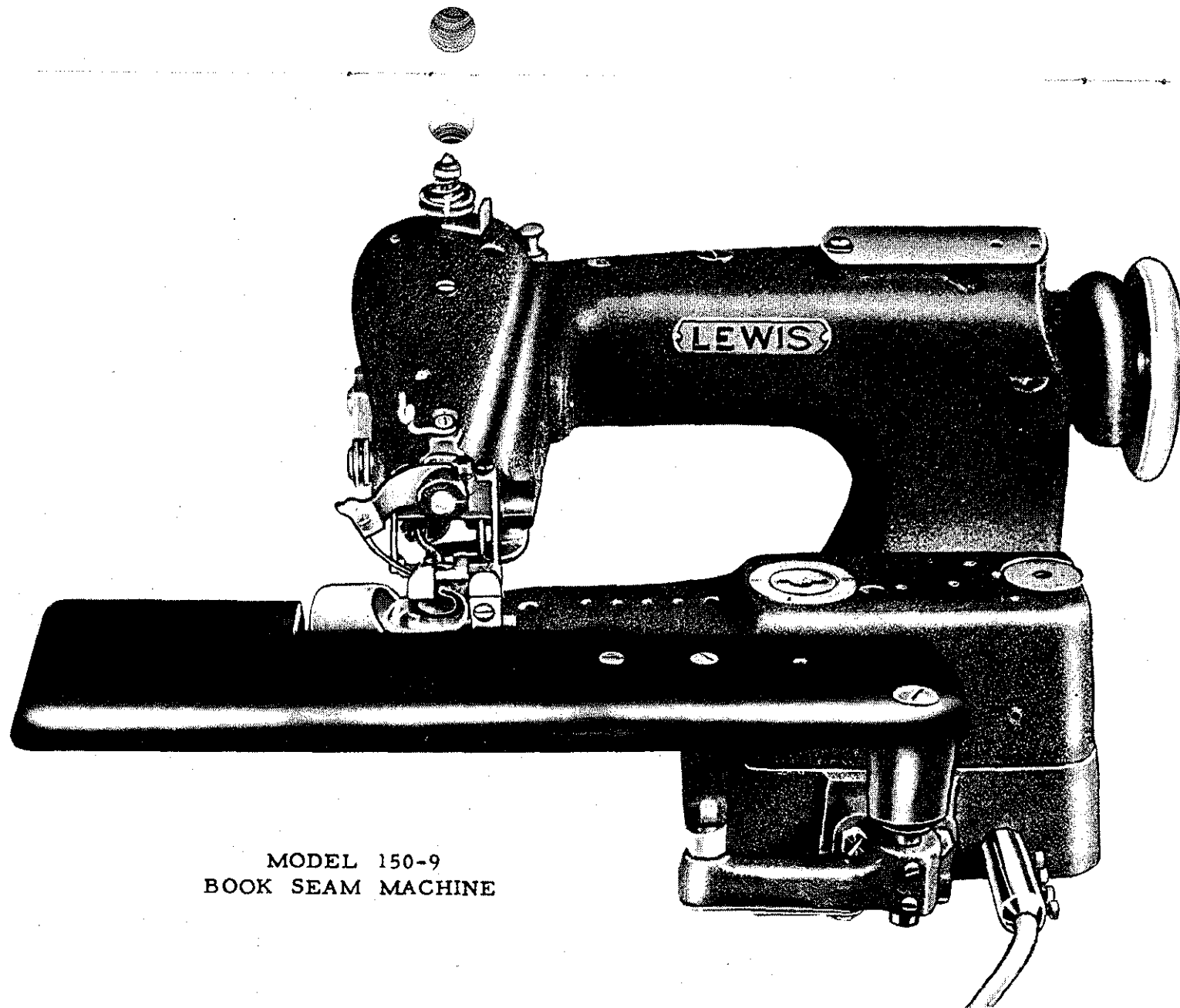

MODEL 150-9
BOOK SEAM MACHINE

One of the
Lewis Class 150 Single Thread Chain Stitch Sewing Machine

MODEL 150-9

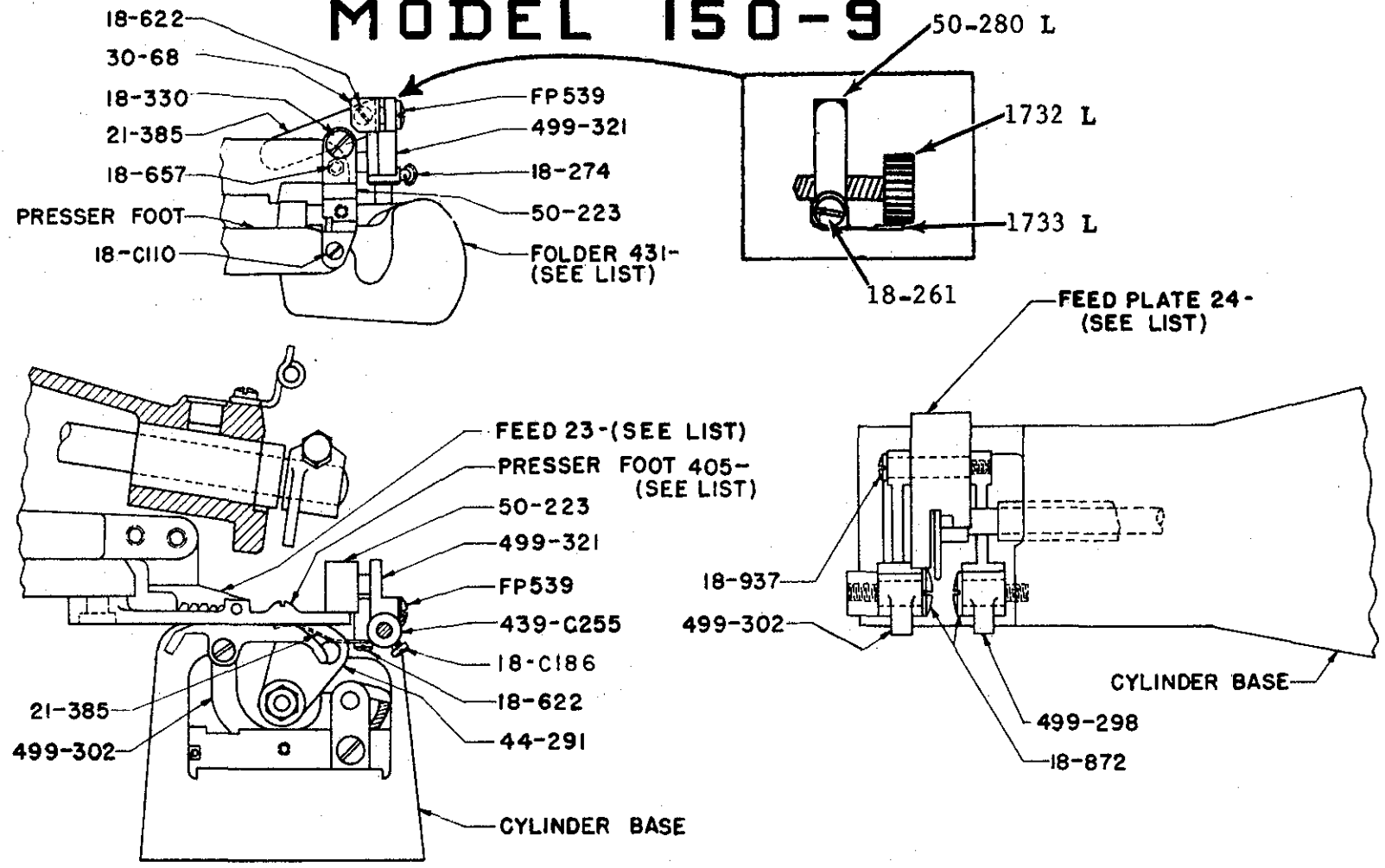

PLATE 13

114-116

PARTS FOR MODEL 150-9

Sewing Turned Under Flat Seams
(Book Seam)

<u>Part No.</u>	<u>Plate</u>	<u>Description</u>
18-C110	13, 14	Screw for attaching Folder Bracket 50-223 to presser feet, Models 150-9 and 150-15
18-C186	13, 14	Set Screw for Collar 39-C255 for locating folders, Model 150-9 and 150-15
18-261	13	Screw for attaching 1733 L to 50-280 L
18-330	13, 14	Screw for bracket 50-223
18-622	13	Screw for spring 21-385
18-657	13, 14	Screw for clamping folder holders to foot, Models 150-9 and 150-15
18-872	13	Shoulder Bearing Screw for feed plate holders
18-937	13	Shoulder Bearing Screw for feed plate
23-310	13, 23	Feed Point, 3/32 pitch, 1/4 inch seam
23-311	13, 23	Feed Point, 3/32 pitch, 3/8 inch seam
24-294	13, 23	Feed Plate, 1/4 inch seam
24-295	13, 23	Feed Plate, 3/8 inch seam
44-291	13, 23	Ridge Forming Disc
50-223	13, 14	Bracket on Presser Foot for folders, Models 150-9 and 150-15
50-280 L	13	Bracket for folder adjusting screw
122-43	*	Chaining Finger for foot 405-537
404-127	13	Work Support Assembly, swing type
405-537	23	Presser Foot, complete, for 1/4 inch book seam, composed of 5-537, 6-56, 18-292, 18-643 and 122-43
405-538	23	Presser Foot, complete, for 3/8 inch book seam, composed of 5-538, 6-56, and 18-643
FP505	13, 16	Screw for Cover 32-229 on bottom of Bracket 50-234, Model 150-9 and 150-16
FP-539	13	Screw for clamping folder
431-L175 3/16	23	Folder for 3/16 inch light materials
431-M175 3/16	23	Folder for 3/16 inch medium materials
431-175 3/16 H	23	Folder for 3/16 inch heavy materials
431-L175 1/4	23	Folder for 1/4 inch light materials
431-M175 1/4	23	Folder for 1/4 inch medium materials
431-H175 1/4	23	Folder for 1/4 inch heavy materials
1732 L	13	Knurled adjusting screw
1733 L	13	Retaining Spring for 1732 L

Parts not listed are common to Model 150-1. See Plates 2 to 9, Pages 46 to 53.

PARTS FOR MODEL 150-9

Sewing Turned Under Flat Seams
(Book Seam)

<u>Part No.</u>	<u>Plate</u>	<u>Description</u>
431-175 5/16L	23	Folder for 5/16" light materials.
431-175 5/16M	23	Folder for 5/16" medium materials.
431-175 5/16H	23	Folder for 5/16" heavy materials.
431-L175 3/8	23	Folder for 3/8" light materials.
431-M175 3/8	23	Folder for 3/8" medium materials.
431-H175 3/8	23	Folder for 3/8" heavy materials. Use holder 499-323 with this Folder.
439-C255	13	Collar on Shank of Folder to locate folder in Presser Foot.
499-321	13	Holder complete for Folders 431-175 (except 431-175-3/8 H - See 499-323)
499-323	*	Holder complete for Folder 431-175 3/8 H only.
499-298	13	Holder for Feed Plate (right hand).
499-302	13	Holder for Feed Plate (left hand).
41355 U	*	Spacer for 18-937

Parts not listed are common to Model 150-1, (See Plates 2 to 9, Pages 46 to 53)

MODEL 150-15

The Model 150-15 is fitted for producing a rolled edge (some time called hand rolled) on

Scarfs
Evening Gowns
Dresses
Slips
Lingerie
House Coats
Play Suits
Novelties

The machine is equipped with a swing work plate so that cylindrical as well as flat work can be rolled edged. The machine is equipped with one folder.

Unless instructed otherwise the machine will be shipped with folder 431-149 which produces a 1/8" rolled edge on medium weight material, such as used in making slips, and if the weight of material is lighter or heavier the width of the hem may vary some what.

We have available at extra charge folders 431-147 for rolled edging such as the flimsy material used in making scarves, and sizes up to the large folders, 431-159 for the extra heavy work.

See General Instructions for class 150 machines, for setting up and adjusting the Model 150-15 machines.

The standard setting of the ridge forming disc is .093" from the right side of the opening in the presser foot.

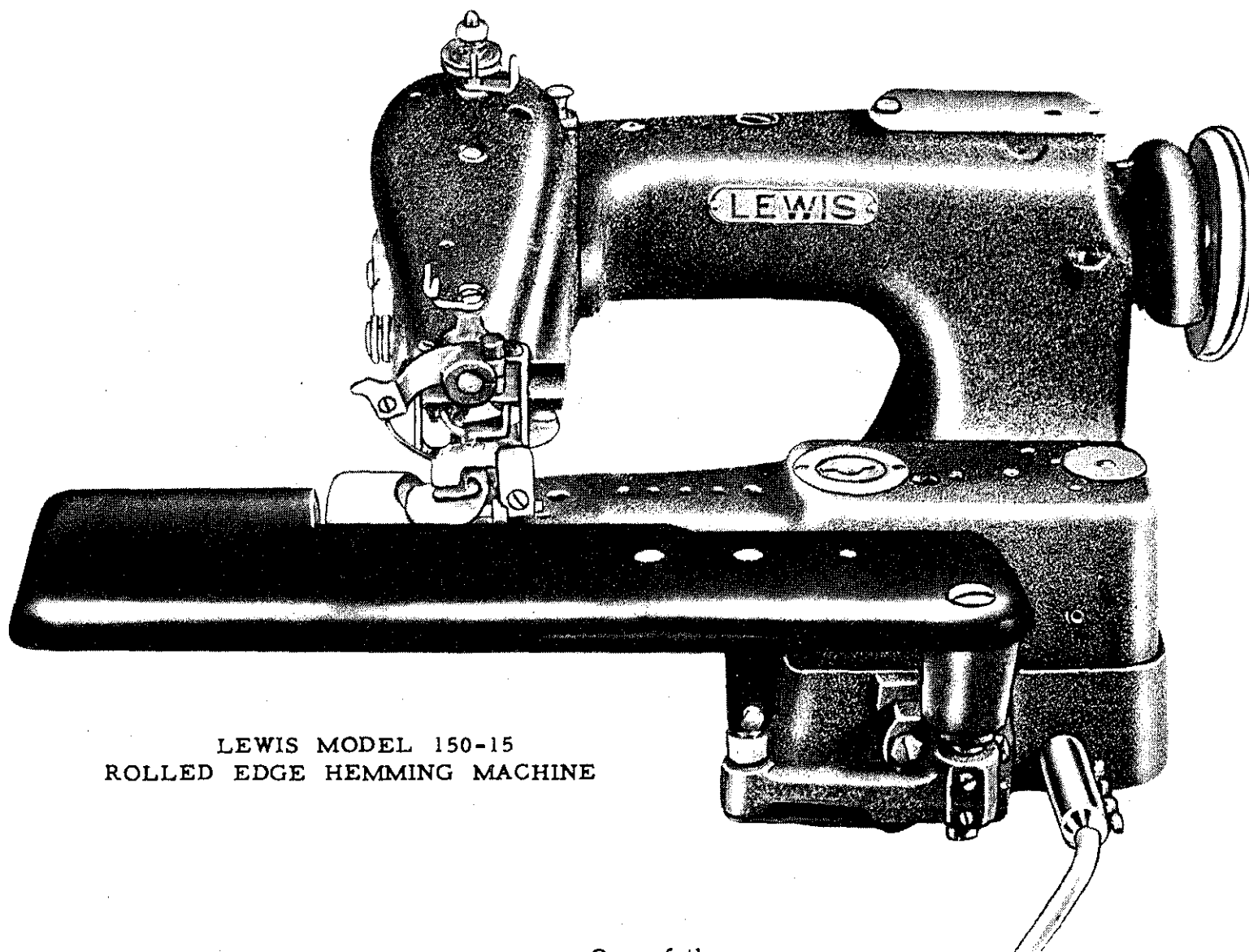

LEWIS MODEL 150-15
ROLLED EDGE HEMMING MACHINE

One of the
Lewis Class 150 Single Thread Chain Stitch Sewing Machine

MODEL 150-15

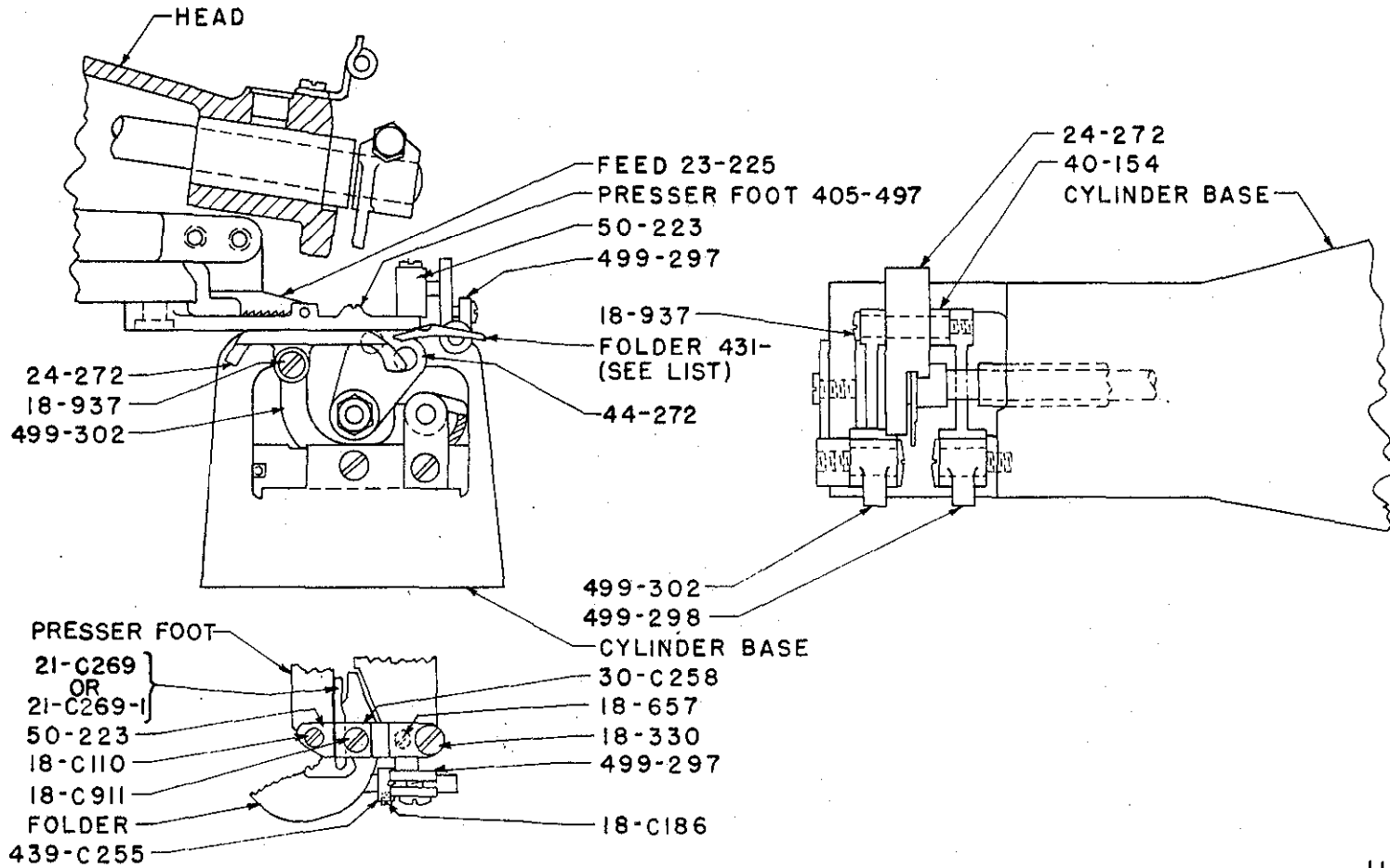

114-117

PARTS FOR MODEL 150-15

For Rolled Edge

<u>Part No.</u>	<u>Plate</u>	<u>Description</u>
18-C110	13, 14	Screw for attaching Folder Bracket 50-223 to Presser Feet
18-C186	14	Set Screw for Collar 439-C255
18-330	2, 13, 14	Screw for Bracket 50-223
18-567	13, 14	Screw for clamping folders to foot, Models 150-9 and 150-15
18-C911	14	Screw on hemmer bracket for cloth retainer spring
18-937	14	Shoulder Bearing Screw for Feed Plate
21-C269	14	Hemmer Spring on Presser Foot 405-497 when using Folders 431-149, 431-150, 431-159
21-C269-1	14	Hemmer Spring for Folders 431-147, 431-148
23-225	14, 23	Feed 1/16 Pitch
24-272	23	Feed Plate for Roll Edge
30-C258	14	Clamp for hemmer spring on Presser Foot
40-154	14	Washer between Feed Plate 24-272 and Holder 99-298 in Cylinder Base
44-272	14, 23	Ridge Forming Disc for rolled Hem
50-223	14	Bracket on Presser Foot for Folders, Models 150-9 and 150-15
122-37	*	Chaining Finger
405-497	23	Presser Foot for Rolled Hem
431-147	23	Folder for extra light work, use Spring 21-C269-1
431-148	23	Folder for light work, use Spring 21-C269-1
431-149	23	Folder for medium work, use Spring 21-C269
431-150	23	Folder for heavy work, use Spring 21-C269
431-159	23	Folder for extra heavy work, use Spring 21-C269
439-C255	14	Collar on shank of Folder to locate folder in presser foot
499-297	14	Holder complete with shaft for folders
499-298	14	Holder for Feed Plate (right hand) in Cylinder Base
499-302	14	Holder for Feed Plate (left hand) in Cylinder Base

Parts not listed are common to Model 150-1. See Plates 2 to 9, Pages 46 to 53.

MODEL 150-16, 150-20

The Model 150-16 has been developed to make 5/16" or 3/8" wide blind stitched belt loops, and is equipped with trimming knives for cutting the material to the correct width to pass through the folders.

Model 150-20 is quite similar to Model 150-16 except that the folder produces a double inturned edge finish whereas on the Model 150-16, the folder produces an overcast raw edge finish.

When using either model on thin or hard to handle material, a buckram filler is recommended. Part 499-319 may be used to hold the reel of buckram for automatic feeding thru the folder.

See Instructions in this section of catalogue for operating machine, and for parts and folders required for each size belt loop.

See General Instructions for Class 150 machines not found in the instructions for Model 150-16 machine.

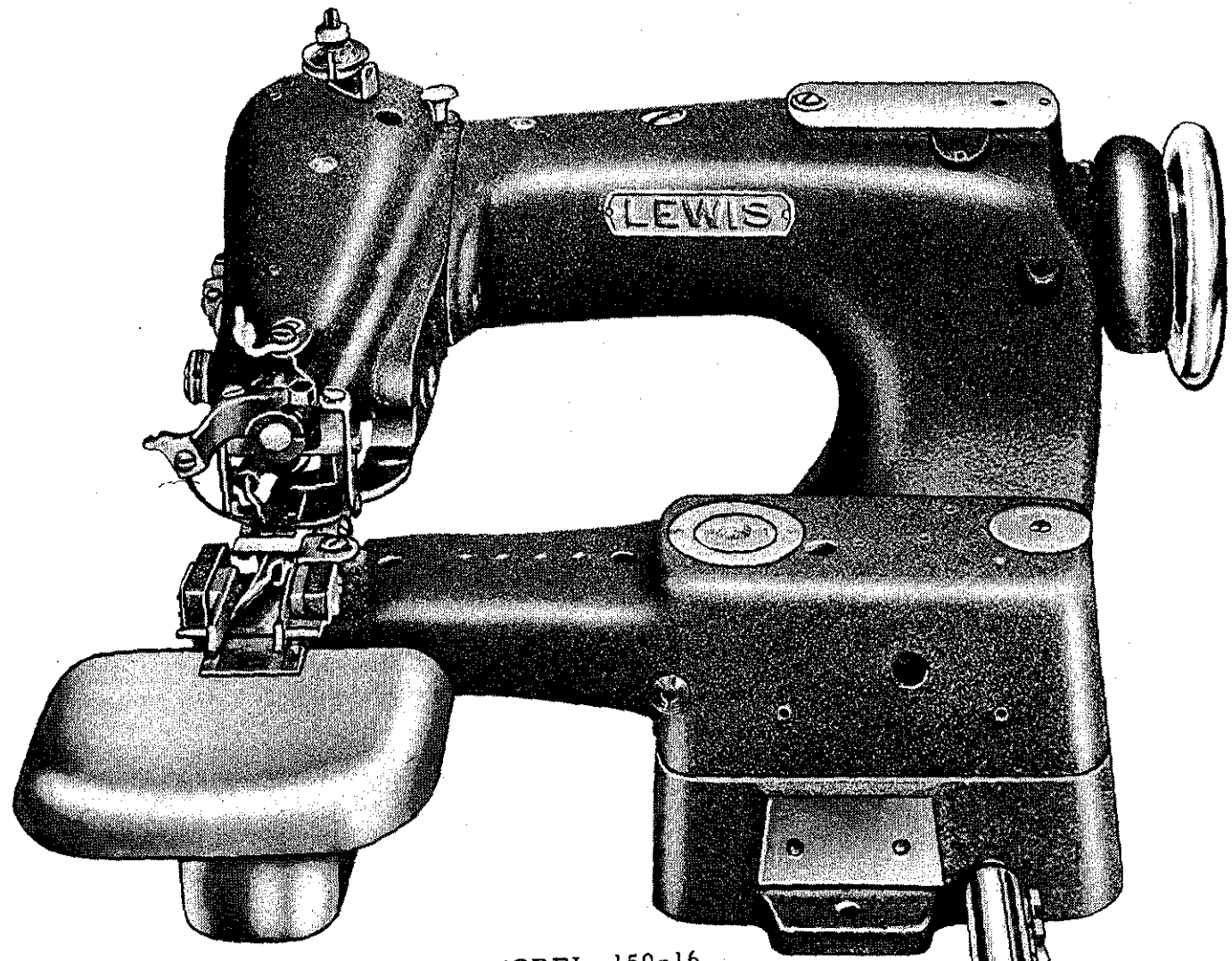

LEWIS MODEL 150-16
BELT LOOP MACHINE

One of the
Lewis Class 150 Single Thread Chain Stitch Sewing Machine

MODEL 150-16, 150-20

PARTS THAT ARE BOXED THUS ARE REFERRED TO IN THE INSTRUCTION FOR MODEL 150-16

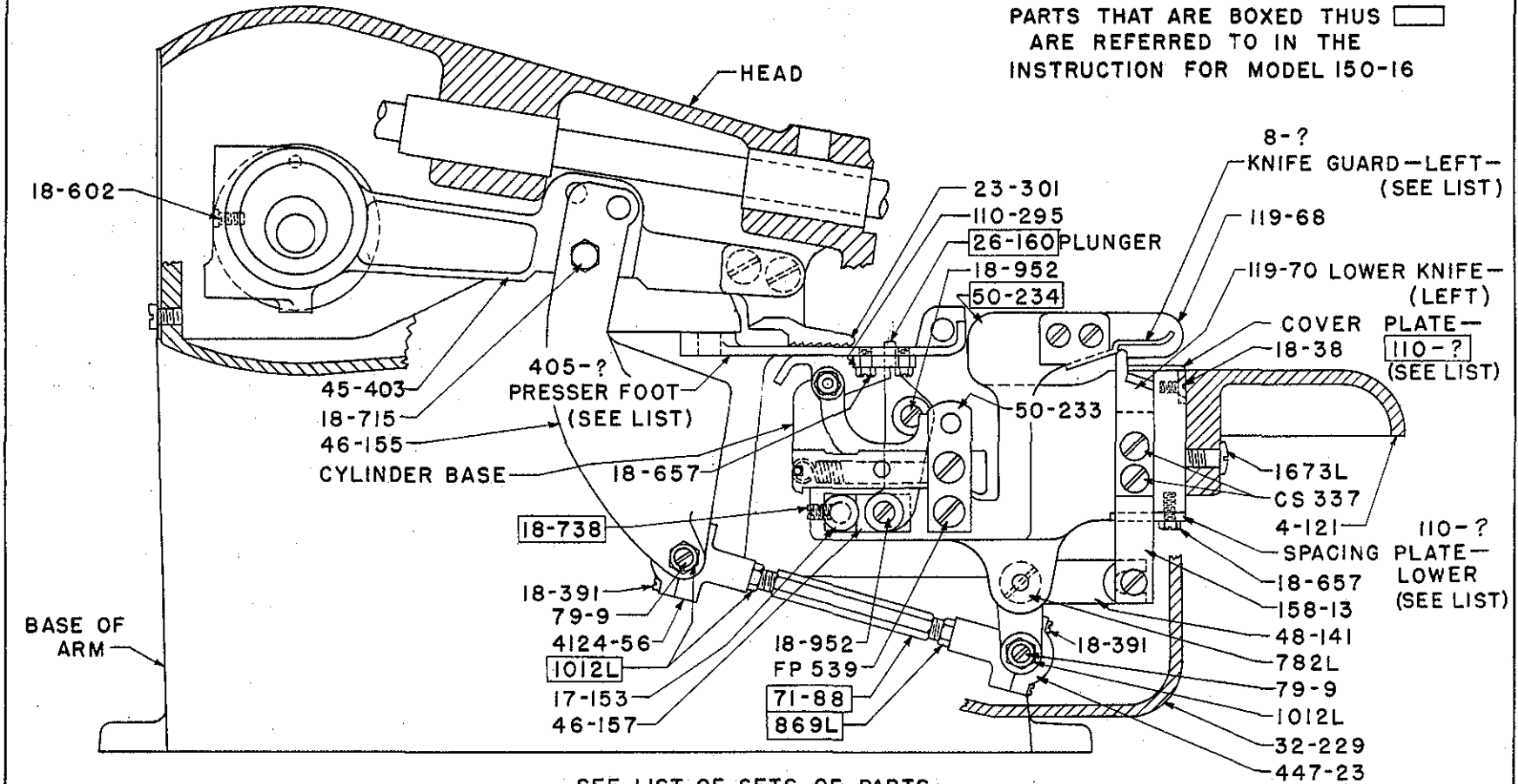

SEE LIST OF SETS OF PARTS FOR VARIOUS WIDTHS OF BELT LOOPS

114-107

PLATE 15

MODEL 150-16, 150-20

PARTS THAT ARE BOXED THUS ARE REFERRED TO IN THE INSTRUCTION FOR MODEL 150-16

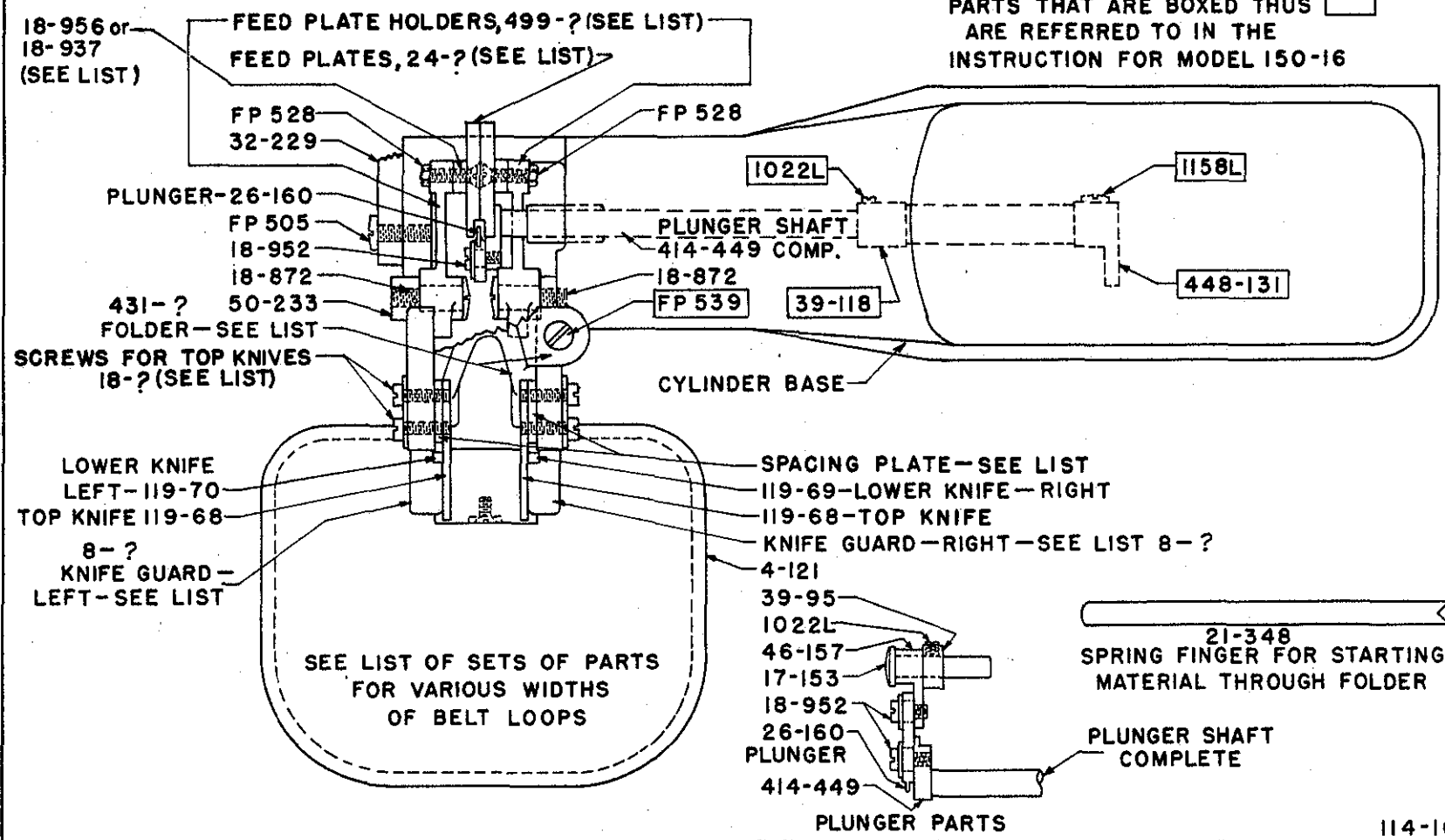

PLATE 16

114-107

MODEL 150-16, 150-20

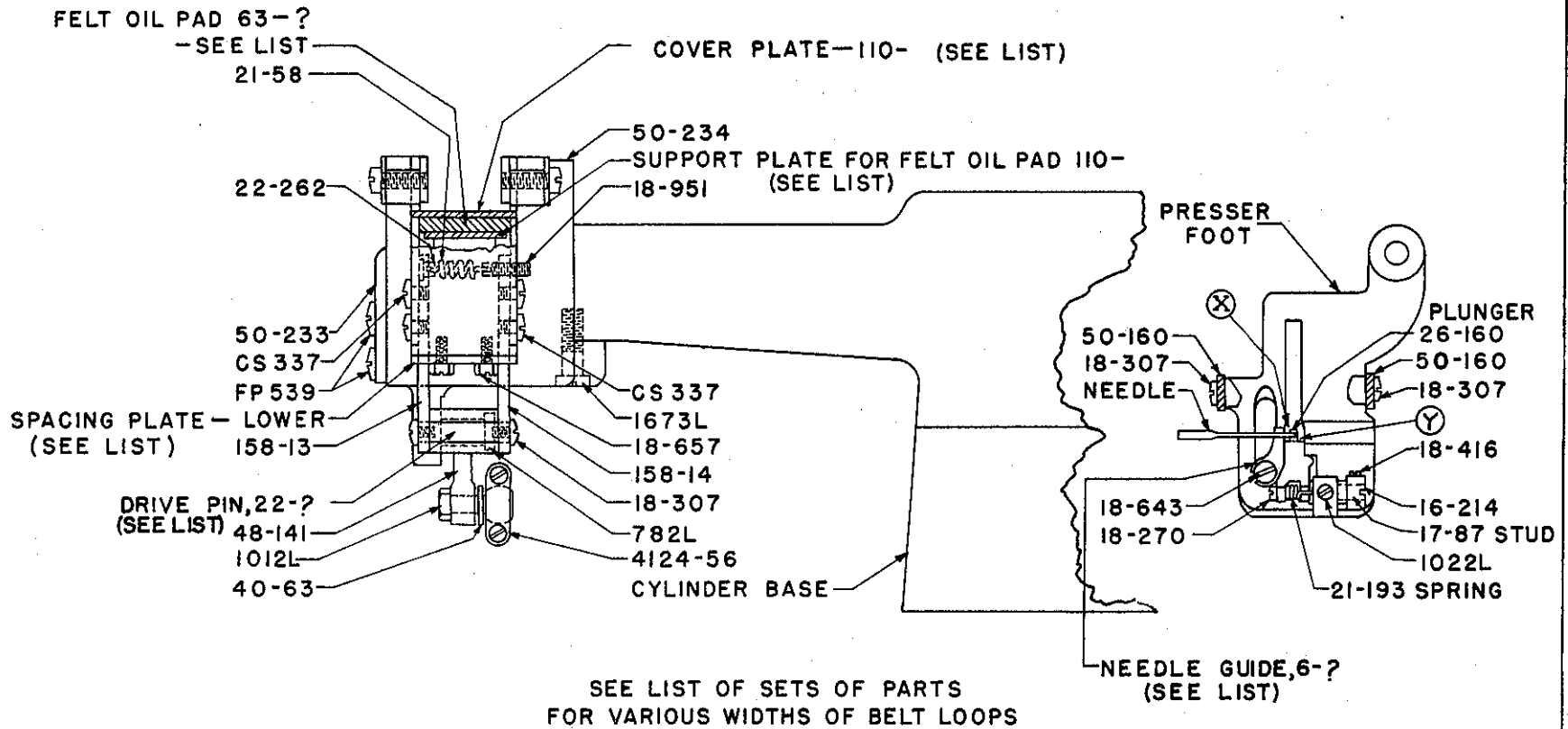

PLATE 17

114-107

PARTS FOR MODEL 150-16, 150-20

For Trimming and Sewing Belt Loops

<u>Part No.</u>	<u>Plate</u>	<u>Description</u>
4-121	15, 16	Aluminum Work Plate attached to Bracket 50-234
6-56	17, 24	Needle Guide, Model 150-16
6-70	17	Needle Guide, Model 150-20
8-122	16, 24	Guard for right hand top knife, Model 150-16, 3/8"; Model 150-20, 5/16"
8-123	16-24	Guard for left hand top knife, Model 150-16, 3/8"; Model 150-20, 5/16"
8-124	24	Guard for right hand top knife for 5/16" Wide Belt Loop, Model 150-16
8-125	16, 24	Guard for left hand top knife for 5/16" Wide Belt Loop, Model 150-16
8-128	16	Guard for right hand top knife, Model 150-20, 3/8"
8-129	16	Guard for left hand top knife, Model 150-20, 3/8"
16-214	17, 24	Bushing in Presser Foot for adjusting cloth retainer
17-87	24	Eccentric Stud in bushing 16-214 for adjusting cloth retainer 137-131 and 137-139
17-153	15, 16, 24	Stud for Plunger Link 46-157 in Cylinder Base
18-38	15	Screw for attaching Cover Plates, 110-236 and 110-237 to Bracket 50-234
18-270	17	Screw in end of stud 17-87 in Foot
18-307	17	Screw for attaching Bracket 50-160 to Presser Feet and for holding 22-257 for driving lower knives
18-375	16	Screws for top knives, Model 150-16, 3/8"; Model 150-20, 5/16"
18-391	15	Screws for Ball Joint Cap on 447-23 and 4124-56
18-400	16	Screws for top knives, Model 150-20, 3/8"
18-416	17	Screw in Bushing 16-214 in Foot
18-602	15	Screw in stitch regulator 149-16 to limit length of stitch
18-643	17	Screw for Needle Guide

Parts not listed are common to Model 150-1. See Plates 2 to 9, Pages 46 to 53.

PARTS FOR MODEL 150-16, 150-20

For Trimming and Sewing Belt Loops

<u>Part No.</u>	<u>Plate</u>	<u>Description</u>
18-657	15,17	Screw for attaching Guide Plate 110-295 to bottom of Presser Foot.
18-715	15	Screw for Knife Driving Link 46-155 under Head.
18-738	15	Screw for holding Stud 17-153.
18-872	16	Shoulder Bearing Screw for Feed Plate Holders 99-298 and 99-307 in Cylinder Base.
18-937	*	Feed Plate Bearing Screw, Model 150-20.
18-951	17	Screw for adjusting pressure of lower knives.
18-952	15,16	Bearing Screws for Plunger 26-160 in Cylinder Base.
18-956	16	Flathead Bearing Screws for Feed Plates.
18-957	16	Screws for Top Knives, Model 150-16, 5/16".
21-58	17	Tension Spring for Lower Knives.
21-193	17,24	Spring for cloth retainer on Presser Foot.
21-348	16	Spring Finger for starting material through folder.
22-257	17	Pin in Crank 48-141 for driving lower knives, Model 150-16.
22-262	17	Spring Pin for Spring 21-58.
22-286	17	Pin in Crank 48-141 for driving lower knives, Model 150-20.
23-301	15,24	Feed.
24-277	16	Feed Plate, Right Hand, Model 150-16.
24-278	16	Feed Plate, Left Hand, Model 150-16.
24-300	*	Feed Plate, Model 150-20.
26-160	15,16,17,24	Plunger for Node in Cylinder Base.
32-229	15,16	Cover for Bottom of Bracket, 50-234.
39-95	16	Collar for Plunger Link Stud 17-153 in Cylinder Base.
39-118	16	Collar on Ridge Forming Disc Shaft.
40-63	17	Fiber slap washer for 4124-56 Ball Joint under Head.
45-403	15	Feed Lever in Head.
46-155	15	Drive Link for knives under Head.
46-157	16,15	Plunger Link.
48-141	15,17	Crank for driving lower knives.

Parts not listed are common to Model 150-1. See
Plates 2 to 9, Pages 46 to 53.

PARTS FOR MODEL 150-16, 150-20

For Trimming and Sewing Belt Loops

<u>Part No.</u>	<u>Plate</u>	<u>Description</u>
50-233	15,16,17	Bracket on end of Cylinder Base for Feed Plate Holder.
50-234	15,17	Bracket attached to Cylinder Base for Belt Loop Knives.
63-29	17,24	Felt Oil Pads, between lower knives, Model 150-16, 3/8"; Model 150-20, 5/16".
63-30	17,24	Felt Oil Pads between lower knives for 5/16" wide belt loops, Model 150-16.
63-33	17	Felt Oil Pads, between lower knives, Model 150-20, 3/8".
71-88	15	Connecting Rod only under Head for operating knives.
79-9	15	Ball Stud in Ball Joints 447-23 and 4124-56.
110-234	17,24	Spacing Plate for Lower Knives for Model 150-16, 3/8"; Model 150-20, 5/16".
110-236	17,24	Cover plate for Bracket 50-234 for Model 150-16, 3/8"; Model 150-20, 5/16".
110-237	17,24	Cover Plate for Bracket 50-234 for 5/16" wide belt loops, Model 150-16.
110-238	17,24	Spacing Plate for lower knives for 5/16" wide belt loops, Model 150-16.
110-285	16,24	Spacing Plate or Shim for top knives for Model 150-16, 3/8"; Model 150-20, 5/16".
110-286	16,24	Spacing Plate or Shim for top knives for 5/16" wide belt loops, Model 150-16.
110-293	17,24	Supporting Plate for Felt Oil Pads, Model 150-16, 3/8"; Model 150-20, 5/16".
110-294	17,24	Supporting Plate for felt oil pads between lower knives 5/16" wide belt loops, Model 150-16.
110-295	15	Plates for guiding belt loops on bottom of Presser Foot.
110-310	17	Spacing Plate for lower knives, Model 150-20, 3/8".
110-311	17	Cover Plate for bracket 50-234, Model 150-20, 3/8".
110-312	17	Supporting Plate for felt oil pads between lower knives 3/8" wide belt loops, Model 150-20.

Parts not listed are common to Model 150-1. See Plates 2 to 9, Pages 46 to 53.

PARTS FOR MODEL 150-16, 150-20

For Trimming and Sewing Belt Loops

<u>Part No.</u>	<u>Plate</u>	<u>Description</u>
110-314	16	Spacing Plate or Shim for top knives for 3/8" wide beltloops, Model 150-20
119-68	15, 16, 24	Top knives for Belt Loop Machine Model 150-16
119-69	16, 24	Bottom knives, right hand side for Belt Loop Machine, Model 150-16
119-70	15, 16, 24	Bottom knife, left hand side for Belt Loop Machine, Model 150-16
137-131	24	Cloth retainer for Medium and Heavy work on Presser Foot 405-518
137-139	24	Cloth retainer for Light and Medium work on Presser Foot 405-517
158-13	15, 17	Slide Plate for lower knife, left hand side
158-14	17	Slide Plate for lower knife, right hand side
CS 337	15, 17	Screws for lower knives
FP 505	16	Screw for Cover 32-229
FP 528	16	Nuts for flat head bearing screws 18-956 for Feed Plates
FP 539	15, 16, 17	Screw for Bracket 50-233 on end of Cylinder Base, and to attach folder to Bracket 50-234
782 L	15, 17	Screw for Crank 48-141 for driving lower knife
869 L	15	Nut (left hand thread) for Ball Joint Connecting Rod under head
1012 L	15, 17	Nut for Ball Screw 79-9 in Cylinder Base
1022 L	16, 17	Screw for Collar 39-95, and in Presser Foot
1158 L	16	Clamp Screw for Crank 448-131
1673 L	15, 17	Screws for holding bracket 50-234 to Cylinder Base, and to hold work plate 4-121 to 50-234
405-517	24	Presser Foot complete for light and medium material composed of Foot, 6-56, 16-214, 17-87, 18-270, 18-416, 18-643, (4) 18-657, 21-193, (2) 110-295, 137-139 and 1022 L, Model 150-16

Parts not listed are common to Model 150-1. See Plates 2 to 9, Pages 46 to 53.

PARTS FOR MODEL 150-16, 150-20

For Trimming and Sewing Belt Loops

<u>Part No.</u>	<u>Plate</u>	<u>Description</u>
405-518	24	Presser Foot complete for medium and heavy materials composed of Foot, 6-56, 16-214, 17-87, 18-270, 18-416, 18-643, (4) 18-657, 21-193, (2) 110-295, 137-131 and 1022 L, Model 150-16
405-560	*	Presser Foot complete composed of Foot, 6-70, 18-643, Model 150-20
414-449	16	Plunger Shaft complete in Cylinder Base
431-169	16, 24	Folder for 5/16" wide belt loop, light to medium material
431-170	16, 24	Folder for 5/16" wide belt loop, medium to heavy material
431-171	16, 24	Folder for 3/8" wide belt loop, light to medium material
431-172	16, 24	Folder for 3/8" wide belt loop, medium to heavy material
431-M180-3/8	16	Folder for 3/8" wide belt loop, Model 150-20
431-M180-5/16	16	Folder for 5/16" wide belt loop, Model 150-20
447-23	15	Ball joint complete under Cylinder Base
448-131	16	Crank with Screw 1158 L, on Ridge Forming Disc Shaft
499-298	16	Holder for Feed Plate, complete with Pin, right side, Model 150-16
499-302	*	Holder for feed Plate, complete with Pin, Model 150-20
499-307	16	Holder for Feed Plate, complete with Pin, left side, Model 150-16
499-319	*	Buckram Reel and Holder complete
4124-56	15, 17	Ball joint complete connecting Link 46-155 to Connecting Rod 71-88

Parts not listed are common to Model 150-1. See Plates 2 to 9, Pages 46 to 53.

MODEL 150-16, 150-20

INSTRUCTIONS FOR ADJUSTING AND TIMING LEWIS
BELT LOOP MACHINE

See General Instructions for Class 150 for further information.

Models 150-16 and 150-20 can be fitted to sew a $5/16''$ wide belt loop or a $3/8''$ belt loop. The Standard machine is fitted for the $5/16''$ wide belt loop, and the $3/8''$ belt loop fittings must be specified when ordering.

Parts for $5/16''$ and $3/8''$ wide belt loops are listed on pages 93 and 94.

1. Adjusting and Timing Plunger:

Adjust plunger 26-160 to cloth opening in Presser Foot.

Loosen Screw 1158 L in crank 448-131 and screw 1022 L in collar 39-118, also screw 18-738 in Bracket 50-234 and set plunger so there is $3/64''$ between left side of cloth opening in presser foot and left side of plunger, at "X" as shown on plate No. 17, For Model 150-16. On Model 150-20, the measurement at "X" is $5/32''$ when using $5/16''$ folder and $11/64''$ when using $3/8''$ folder.

2. Adjust Feed:

Set feed on stitches per inch required, not less than 6 stitches per inch. The stitch is regulated by the knob 426-47, plate 3 located on top of the arm of the machine, near the head. First, open the top cover of the machine to observe the feed indicator on the shaft, with numerals which indicate on the number of stitches per inch, press down the feed knob located on top of the machine which will engage a slot in the feed mechanism; now turn the hand wheel over and away from you, while holding the knob in the slot, to lengthen stitch, and toward you to shorten stitch, and observe through the opening in the top of the arm, the number on the feed disc as you turn until the numeral, indicating the stitches per inch, is directly under the indicator.

MODEL 150-16, 150-20

INSTRUCTIONS FOR ADJUSTING AND TIMING LEWIS
BELT LOOP MACHINES

Rotate handwheel clockwise until needle point is even with right side of cloth opening in presser foot as needle travel is from right to left. Loosen two feed point screws 18-732 and set feed so teeth contact feed plattens and front end of feed point is $1/16''$ to rear of needle, tighten 18-732 screws.

3. Adjust Cloth Retainer:

Set front end of retainer in center of cloth opening in presser foot and turn 16-214 bushing clockwise until end of spring 21-193 is on top, tighten 1022 L screw to hold bushing in place. Turn eccentric stud 17-87 until there is $1/32''$ between front end of retainer, and side of needle as shown at "Y" on Plate 17. For heavy materials, set front end of retainer $1/16''$ from side of needle. Tighten 1022 L and 18-416 screws.

4. Adjust Top Knives:

Loosen four knife holding screws and set lower edge of knives $1/8''$ above top of lower knife cover plate. Tighten screws.

5. Adjust Lower Knives:

Turn handwheel clockwise until lower knives are at top of stroke. Loosen nuts 869 L and 1012 L on ball joint connecting rod 71-88 and turn connecting rod until front edge of lower knife is $1/32''$ above bottom edge of top knife. Tighten 869 L and 1012 L nuts.

6. Adjust Folder:

Loosen screw FP 539 and adjust folder sideways until stitch is set at edge of top fold of belt loop. Tighten screw.

MODEL 150-16
PARTS FOR 5/16" AND 3/8" BELT LOOPS

STANDARD

Light to Med. Material Med. to Heavy Material

5/16" Loops	3/8" Loops	5/16" Loops	3/8" Loops	<u>Description</u>
405-517	405-517			Light to Medium Presser Foot complete.
8-124		405-518	405-518	Medium to Heavy Presser Foot complete.
	8-122	8-124		Guard for right top knife, 5/16" loops.
8-125		8-125	8-122	Guard for right top knife, 3/8" loops.
	8-123			Guard for left top knife, 5/16" loops.
63-30		63-30	8-123	Guard for left top knife, 3/8" loops.
	63-29			Oil Pad for 5/16" loop under cover 110-238.
110-237		110-237	63-29	Oil Pad for 3/8" loops under cover 110-236.
	110-234			Cover Plate for Bracket 50-234, 5/16" loops.
110-238		110-238	110-234	Spacing Plate for lower knives, 3/8" loops.
	110-236			Spacing Plate for lower knives, 5/16" loops.
110-286(2)		110-286(2)	110-236	Cover Plate for Bracket 50-234, 3/8" loops.
	110-285(2)			Spacing Plate for top knives, 5/16" loops.
110-294		110-294	110-285(2)	Spacing Plate for top knives, 3/8" loops.
	110-293			Supporting Plate for Oil Pad, 5/16" loops.
431-169			110-293	Supporting Plate for Oil Pad, 3/8" loops.
	431-171			Folder for 5/16" loops, light to med. Mat'l.
		431-170		Folder for 3/8" loops, light to med. Material.
				Folder for 5/16" loops, Med. to Heavy Mat'l.
			431-172	Folder for 3/8" loops, Med. to Heavy Mat'l.

MODEL 150-20

PARTS FOR 5/16" AND 3/8" BELT LOOPS

5/16" Loops	3/8" Loops	Description
405-560	405-560	Presser Foot complete
8-122		Guard for right top knife
8-123		Guard for left top knife
	8-128	Guard for right top knife
	8-129	Guard for left top knife
63-29		Oil Pad under cover 110-236
	63-33	Oil Pad under cover 110-311
110-234		Spacing Plate for lower knives
110-236		Cover Plate for bracket 50-234
110-285		Spacing Plates for top knives
110-293		Supporting Plate for Oil Pad
	110-310	Spacing Plate for lower knives
	110-311	Cover Plate for bracket 50-234
	110-312	Supporting plate for Oil Pad
	110-314	Spacing Plate for top knives
431-M180-5/16		Folder
	431-M180-3/8	Folder

MODEL 150-17

The Model 150-17 was developed for padding Collars and lapels. In some localities operators have become so proficient that they finish the operation without stopping the machine.

The Model is equipped with a foot, having a retainer with a finger so that at the end of each row of stitches the thread will break across the finger instead of across the looper, leaving enough thread protruding from the needle, so that the thread will not come out of the needle when starting the next row of stitches.

The machine is equipped with a Foot Treadle and does not have a work plate.

Refer to General Instructions for setting up and adjusting.

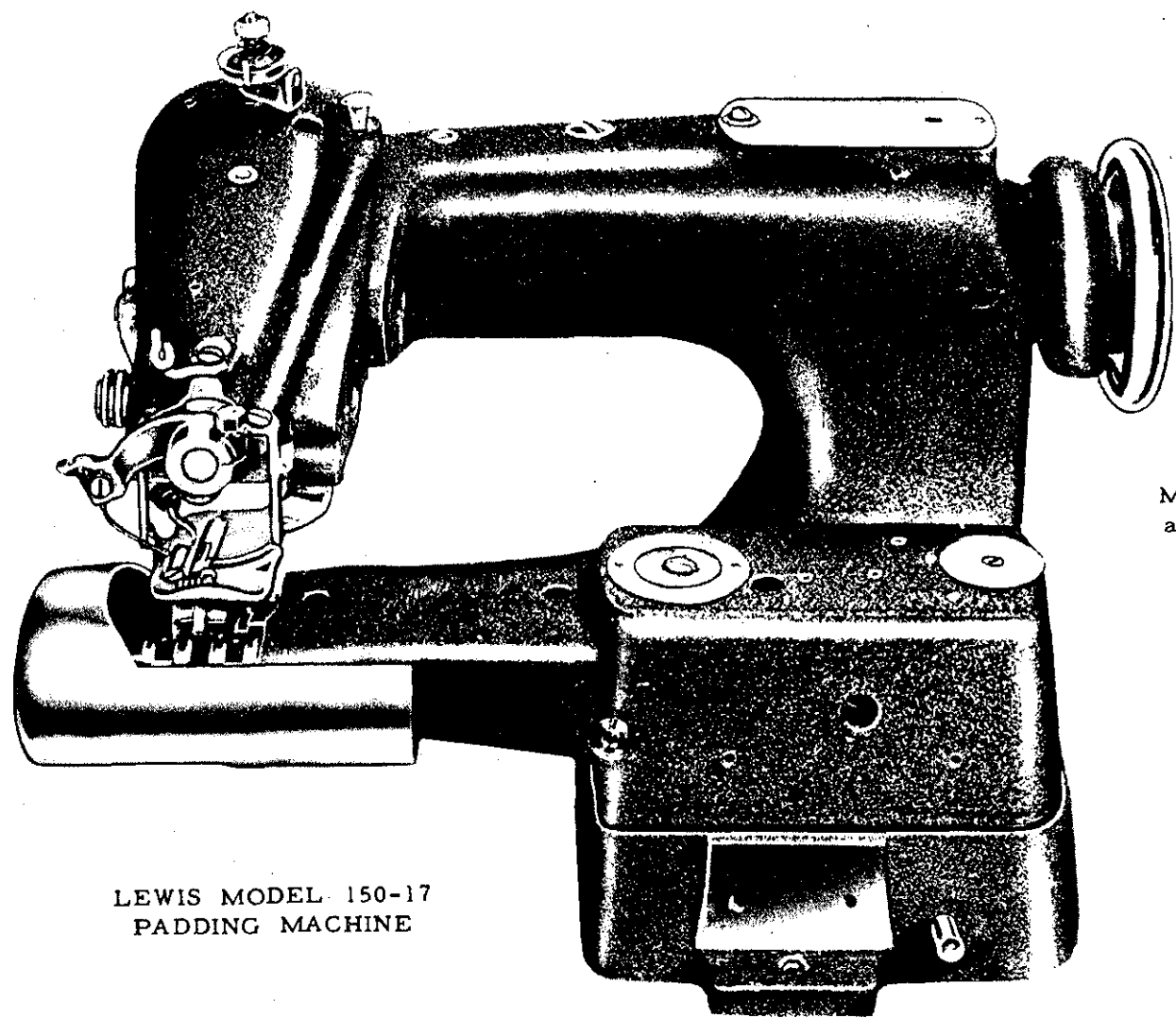

The Machine
is not equipped
with work plate.

Machine is operated by
a foot treadle.

LEWIS MODEL 150-17
PADDING MACHINE

One of the
Lewis Class 150 Single Thread Chain Stitch Sewing Machine



PARTS FOR MODEL 150-17

Padding Collars and Lapels.
 Has Foot with Retainer - -
 Designed to break the thread
 without stopping machine.

<u>Part No.</u>	<u>Plate</u>	<u>Description</u>
6-56	23	Needle Guide.
18-292	23	Screw for Chaining Finger 122-35 on Presser Foot.
18-643	23	Screw for Needle Guide 6-56 on Presser Foot.
21-63	23	Spring for Retainer 4137-126 on Presser Foot.
23-217	23	Feed for Model 150-17.
122-35	23	Chaining Finger on Presser Foot.
130-9	8	Chain for Foot Treadle 4135-9.
131-C163-1	8	Hook for attaching chain to Treadle 4135-9.
405-503	23	Presser Foot complete, for padding Model 150-17.
4135-9	8	Foot Treadle complete with spring, Bracket and Hinge Pin.
4137-126	23	Cloth Retainer for Presser Foot.

Parts not listed are common to Model 150-1. See
 Plates 2 to 9, Pages 46 to 53.

MODEL 150-23

The Model 150-23 machine has been developed to produce a very flexible loose stitch for tacking the facing to the forepart of coats. The operation is sometimes referred to as Bluff Edging.

The machine differs from other Class 150 machines by having a yielding disc made to shog or move from right to left, and the needle penetrates once in the single ply body fabric of the coat when the disc is in the left hand shogging position, feeds once then catches the facing that has been folded over on its self when the disc is in the right hand shogging position, continuing until the operation on the coat has been finished, then facing is turned to it's natural position. The loose tacking blind stitch lies between the facing and the forepart, and will hold the coat in shape.

OPERATING THE MACHINE

Fold the facing over on itself, so that the edge of the fold will be the distance selected from the edge of the coat to sew the tacking stitches, press the knee against the knee press which will lower the feed plate, and recede the ridge forming disc, place one end of the coat with the facing folded under the presser foot with edge of the fold against the front edge guide of the presser foot.

1. To adjust for needle penetration in the single ply body fabric, use the more or less dial on top of the base, and turn the hand wheel of the machine in clockwise direction until the ridge forming disc has shogged or moved to the left hand side of the foot opening and is under the cloth retainer. Continue to turn until the point of the needle is ready to enter the work. Turn the regulator dial to the "MORE" for deeper penetration, and to the "LESS" for less penetration of the needle. Adjust until the needle catches only one or two strands of the body fabric.
2. To adjust for sewing the facing, turn the hand wheel of machine in clockwise direction until the ridge forming disc has shogged to the right hand side of the cloth opening, and is under the crown, and with the needle ready to penetrate the folded facing.

To adjust for needle penetration in the folded facing always use the crown and by turning the knurled headed screw in clockwise direction until the end of the crown forces the facing down, so that the needle will catch about two strands of the facing material.

Sew a few stitches, and if depth of penetration is not quite right, turn the adjustments a notch at a time to correct, bearing in mind the "MORE" or "LESS" regulator adjusts the needle penetration on single layer of body fabric on the left hand side and the crown screw adjusts the needle penetration on the folded facing side.

The edge guide fastened to the front end of the presser foot must be set so the folded edge of the facing will be guided to the projection on the under side of the crown without the edge crowding the crown projection.

ADJUSTING MODEL 150-23

(Letter "P" after part numbers refers to plate number.)

The Model 150-23 machine is constructed the same as other models in the Class 150 machines except the ridge forming disc mechanism is made to shog, or move from right to left, and required an added line of parts to shog the disc so that the needle will pass over the disc alternately penetrating the material first on the left side, and while the machine is feeding the disc moves to the right hand side, and the needle penetration takes place, requiring gears to move the disc every other stitch.

The ridge forming disc oscillates on every stroke of the needle, and is operated by eccentric 433-144 (P20 and P21), and is timed by spot screw 18-700, (P21), therefore, is properly timed when assembled.

The shogging mechanism must be timed relative to the oscillating motion of the ridge forming disc which is accomplished by loosening screws 1029 L (P20 and P21) in gear 27-76 (P21), turn the hand wheel in clockwise direction until the nose of the ridge forming disc when receding is even with the bottom of the presser foot, hold hand wheel in this position and turn the gear 27-76 by hand in clockwise direction until the disc just starts to move either to the right or to the left and tighten set screw 1029 L. Turn the machine over by hand and note that the disc starts to shog when on the receding or backward movement, the nose of the disc is even with the bottom of the presser foot.

When properly timed the machine will be feeding when the disc is shogging and the disc will be in its most forward position when the point of the needle is even with the edge of the needle guide ready to penetrate the material.

The periphery of the ridge forming disc is convex, See 444-275 (P25), and the retainer 137-77, and crown 126-43 and (P25) are both concave on the under sides, and the disc must be set so the periphery of the disc accurately matches the concave shape on the under side of the retainer and crown.

The above adjustment is made by loosening the clamp screw in crank 448-171 (P19) and moving the disc 444-275 and disc shaft 14-394 (P19) so that the disc matches the crown and retainer. When making this adjustment also loosen clamp screw for the lower lever, 448-139 (refer to plate 21), as it is necessary to see that the distance at X is $7/32$ " from side of sleeve 70-55, to the end of cradle 140-12, when the disc is on the right hand shog under the crown. It is also necessary to set the width of the groove (refer to Plate 21) for the bearing Pin, 22-254, use two screw drivers, one through the hole in the top of the base held against the crank 448-171 and one against the side of the sleeve, 70-55, and slide the sleeve so that there will be no shake in bearing pin, 22-254. See that the disc is in place under the crown and distance X is correct. Tighten the screw 1158 in crank 448-171.

Again check to see that the disc matches the concave on the under side of the crown, and distance X is correct, and tighten clamp screw 18-757 in crank, 448-139 securely.

If adjustments have been made correctly there will be no bind in the ball joint 4124-55. Carefully check by turning hand wheel to see that the joint is free in all positions.

Care should be taken when making this adjustment to see that the square headed bearing pin 22-254, that slides in the groove formed by the two parts 70-55 and 448-171 (P21) slides freely in the groove without any play. The groove is adjustable so that a good fit can be maintained to take up wear, as sleeve 70-55 is split and fits into the hole of crank 448-1717 (P21), and is clamped by screw #1158 that also clamps both parts to the disc shaft 14-394, tighten screw securely.

See General Instructions for Class 150 machines for setting up and other adjustments for the Model 150-23 machine.

FOR

(Bluff Edge)

Tacking the facing of
womens' coats can tack
any distance from edge
of the coat.

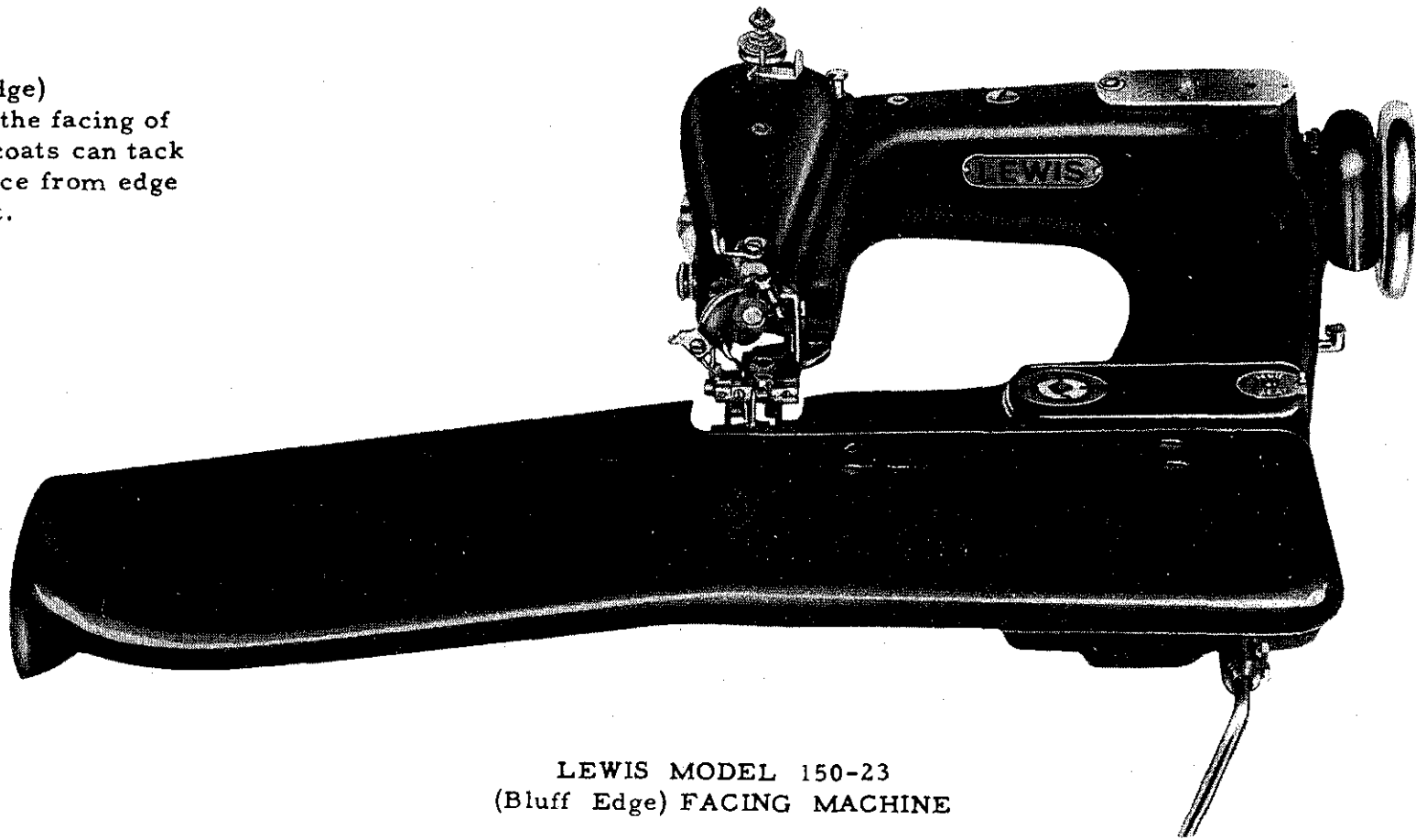

LEWIS MODEL 150-23
(Bluff Edge) FACING MACHINE

One of the
Lewis Class 150 Single Thread Chain Stitch Sewing Machines

MODEL 150-23

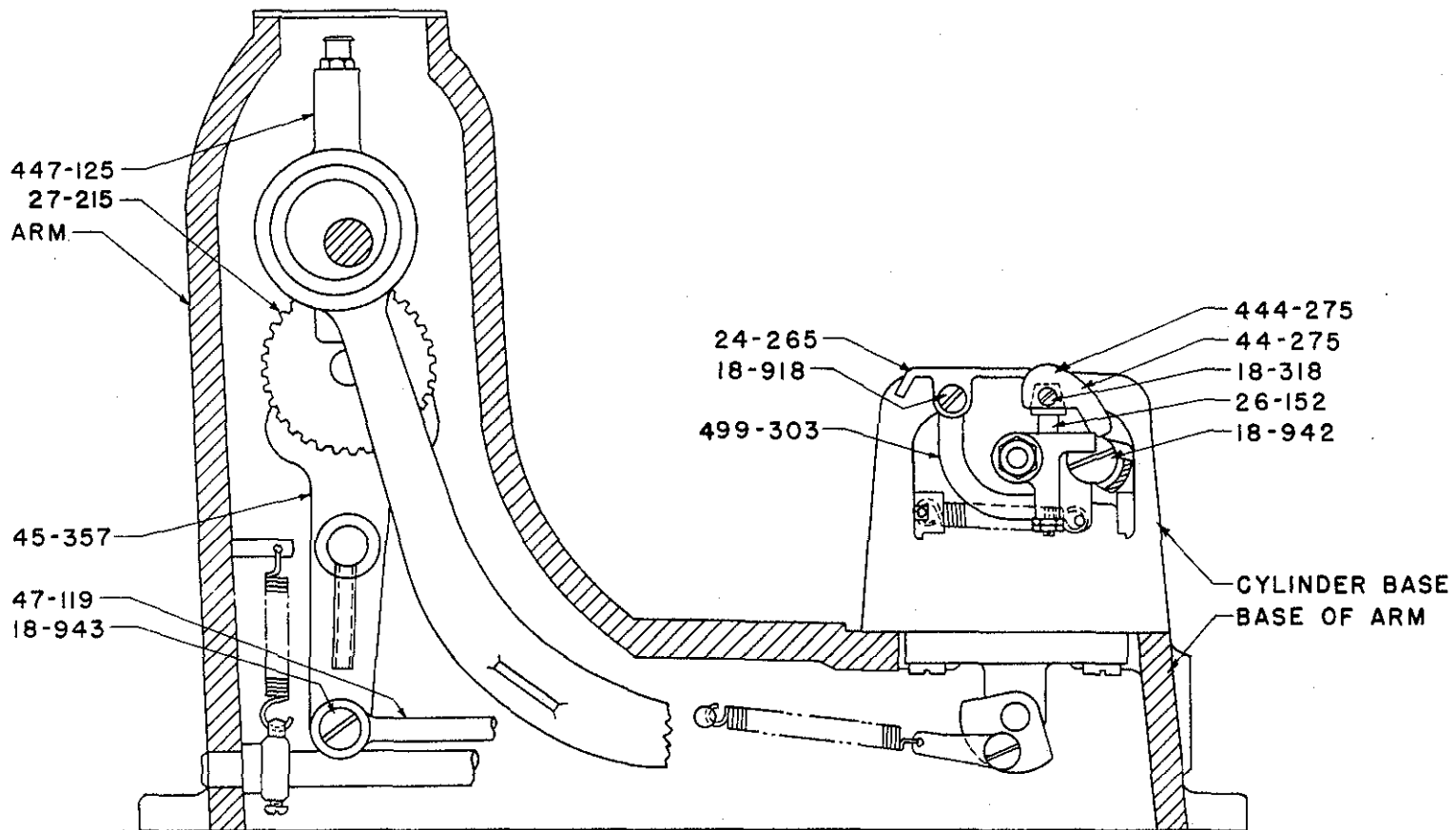

114-118

MODEL 150-23

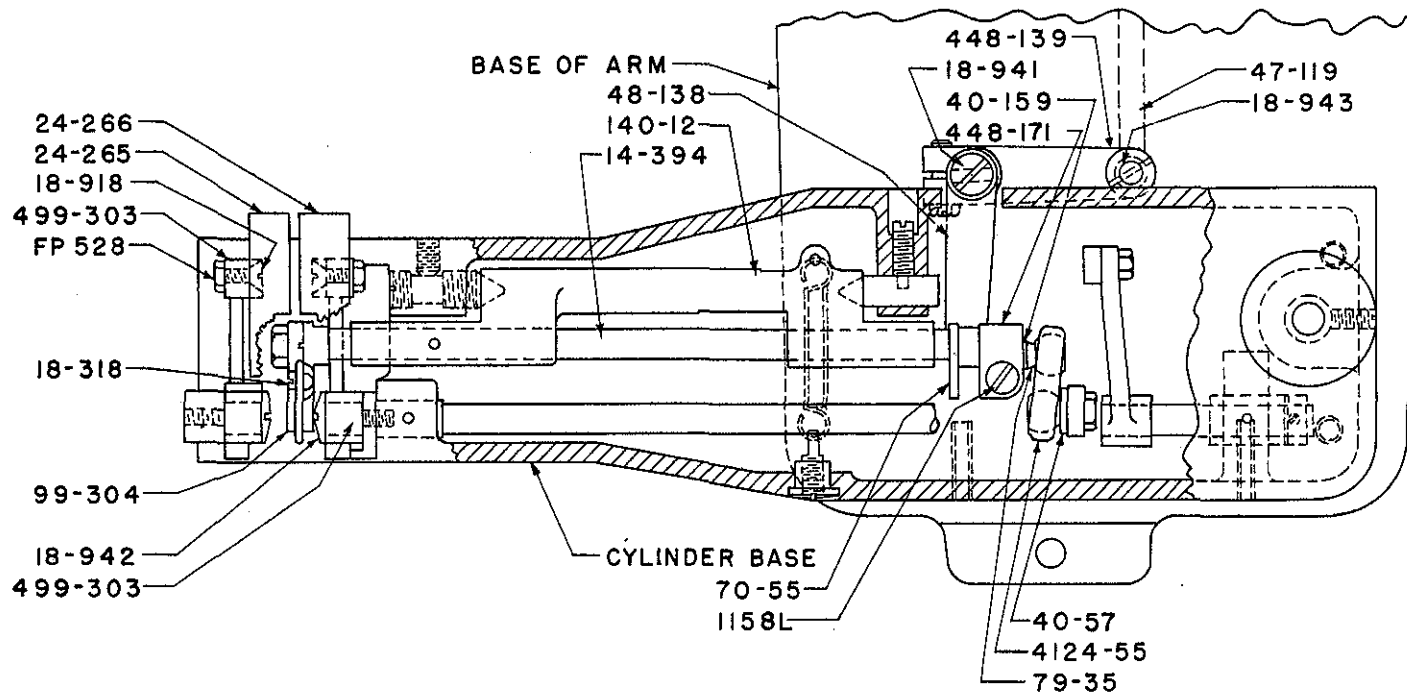
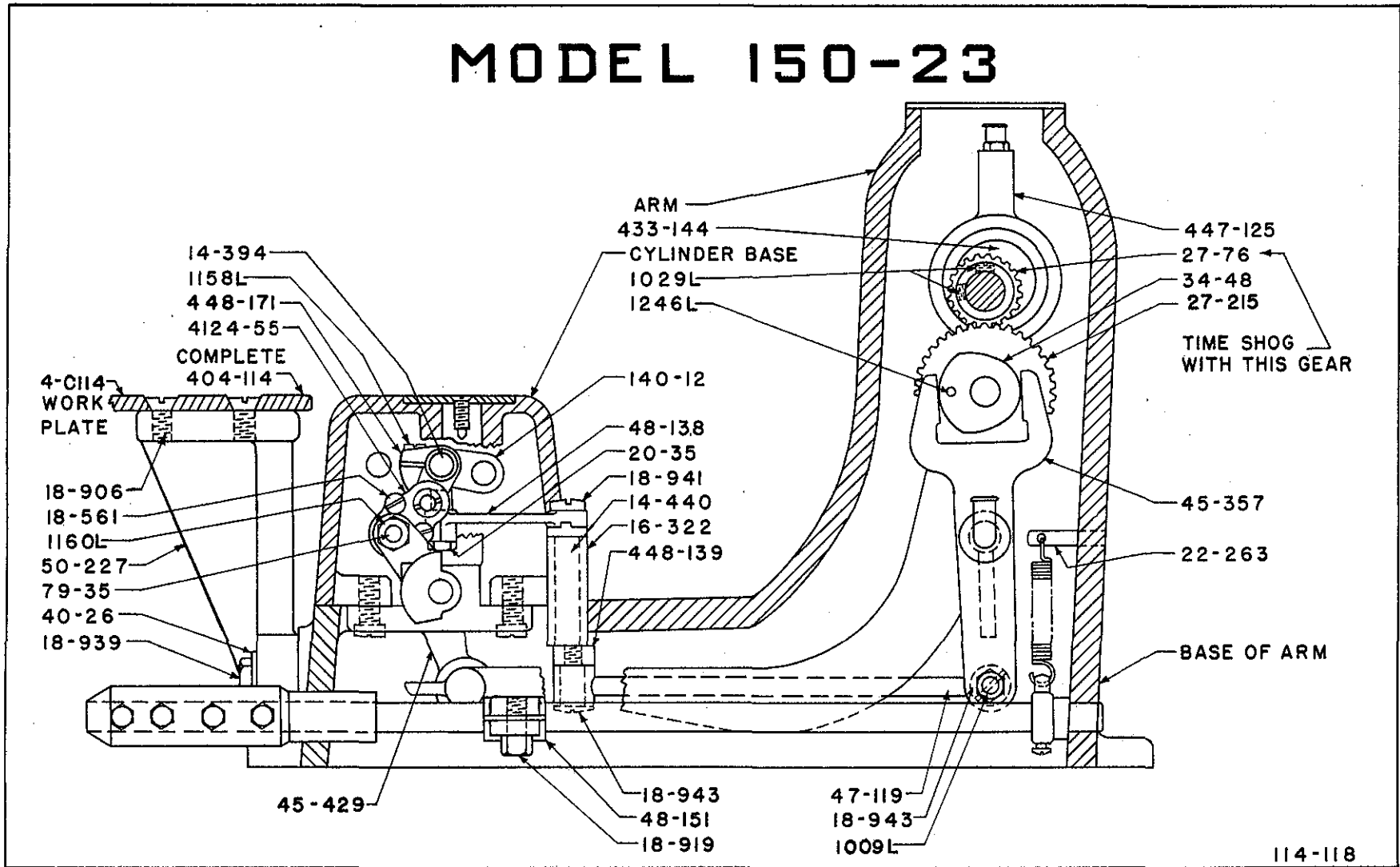

PLATE 19

114-118

MODEL 150-23

PLATE 20



MODEL 150-23

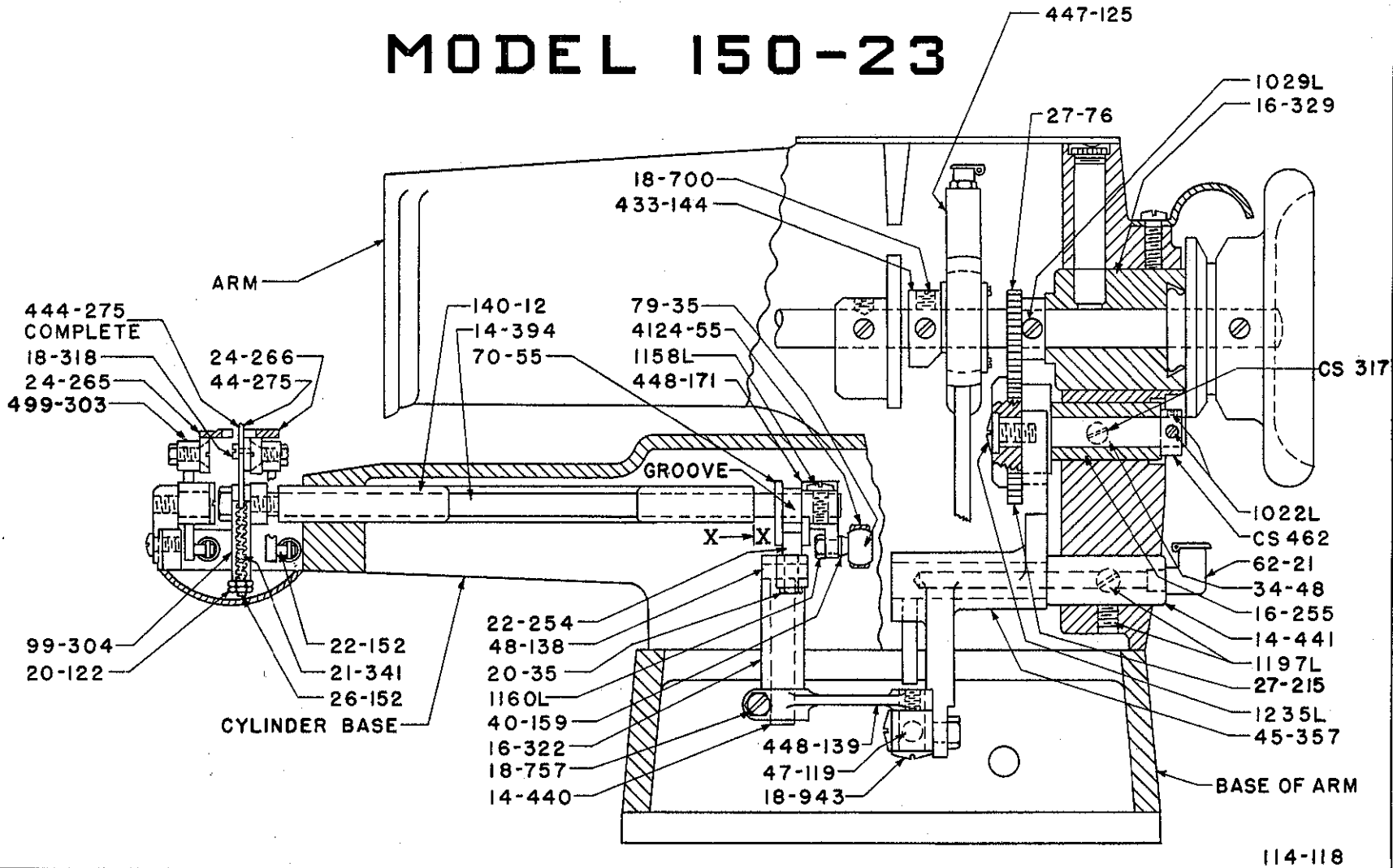

PLATE 21

PARTS FOR MODEL 150-23

Tacking Facing to Forepart
(Bluff Edge)

<u>Part No.</u>	<u>Plate</u>	<u>Description</u>
4-C114	20	Work Plate (large) for Models 150-7 and 150-23
14-394	19, 20, 21	Shaft for Ridge Forming Disc in Cylinder Base
14-440	20, 21	Shaft for Crank 48-138 to Shog Disc, Model 150-23
14-441	21	Jack Shaft in Arm
16-255	21	Bushing (Eccentric) in Arm for adjusting Gear 27-215
16-322	20, 21	Bushing in Base for 14-440 for Shogging Disc
16-329	21	Bushing for Main Shaft Hand Wheel end of Arm
18-318	18, 19, 21, 25	Screw for attaching Ridge Forming Disc 44-275 to Plunger 26-152 in Cylinder Base
18-561	20	Screws in 4124-55 Ball Joint in Base
18-700	21	Spot screw for Ridge Forming Disc Eccentric 433-144
18-757	21	Hex Screw for 448-139 in Base
18-906	20	Flat Head Screws to fasten work plate 4-114 to Bracket
18-918	18, 19	Taper bearing Screws for Feed Plates
18-939	20	Hex Screw for Holding Work Table Bracket 50-227 to Machine
18-941	19, 20	Screw for Crank 48-138 to Shog Disc in Base
18-942	18, 19	Shoulder Bearing Screw for Feed Plate Holder 99-303, Models 150-7, 150-23
18-943	18, 19, 20, 21	Shoulder Bearing Screws for Connecting Rod 47-119
20-35	20, 21	Nut for Bearing Pin 22-254 in Cylinder Base
20-122	21, 25	Nut for Plunger 26-152 in Base, Models 150-7, 150-23
21-243	25	Spring for adjusting screw on Presser Feet with Crown

Parts not listed are common to Model 150-1. See Plates 2 to 9, Pages 46 to 53.

PARTS FOR MODEL 150-23

Tacking Facing to Forepart
(Bluff Edge)

<u>Part No.</u>	<u>Plate</u>	<u>Description</u>
21-341	21, 25	Spring for Plunger 26-152 for Ridge Forming Disc in Cylinder Base, Models 150-7 and 150-23
21-357	25	Spring (heavy) for Plunger 26-152
22-254	21	Bearing Pin for 48-138 in Cylinder Base
22-263	20	Pin for Spring 21-344 in Arm, Model 150-23
23-217	25	Feed
24-265	18, 19, 21, 25	Feed Plate (left) for Models 150-7 and 150-23
24-266	19, 21, 25	Feed Plate (right) for Models 150-7 and 150-23
26-152	18, 21, 25	Plunger for holding Ridge Forming Disc 44-275, Models 150-7, 150-23
27-76	20, 21	Gear on Main Shaft for driving Gear 427-183
27-215	18, 20, 21	Gear for Shogging Disc
32-225	12	Cover for end of Cylinder Base
34-48	20, 21	Cam for Shogging Ridge Forming Disc
40-26	20	Washers for Screw 18-804 for attaching Bracket 50-227 to machine
40-57	19	Slap Washer for 4124-55 in Base
40-159	19, 21	Washer for Ball in Crank 448-137 in Cylinder Base
44-275	18, 21, 25	Ridge Forming Disc, yielding, for fur padding and bluff edge, Models 150-7 and 150-23
45-357	18, 20, 21	Fork Lever for Shogging Ridge Forming Disc in Arm
45-429	20	Lever for oscillating ridge forming disc, in Base of Arm
47-119	18, 19, 20, 21	Connecting Rod for Shogging Ridge Forming Disc in Base of Arm
48-138	19, 20, 21	Crank on Shaft 14-440 for Shogging Disc
48-151	20	Crank on Shaft 14-400 to depress Feed Plates and roll back Ridge Forming Disc
50-227	20	Bracket for Large Work Table 404-114
62-21	21	Oil Cup for Shaft 14-441 in Arm, Model 150-23

Parts not listed are common to Model 150-1. See Plates 2 to 9, Pages 46 to 53.

MODEL 150-1

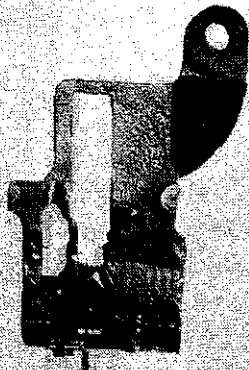

405-393-2 LIGHT
405-394-4 MEDIUM
405-395-1 HEAVY

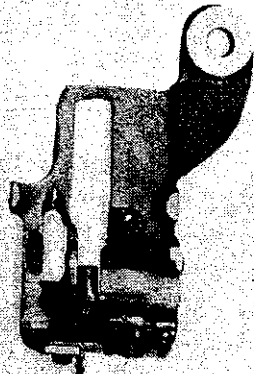

405-419

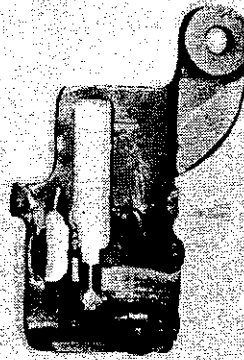

405-508



24-263



24-264



44-253



75-215



44-278



75-210



137-54



44-277



137-123
137-132



23-216

PARTS COMMON TO ALL FEET
ON THIS PAGE AND TO 405-502



18-270



21-193



17-87



16-214



42-13
42-24



122-35
122-39



6-56



18-643



1351L



1022L



18-416



18-623



18-292



164-9

MODEL 150-5



44-254
44-296

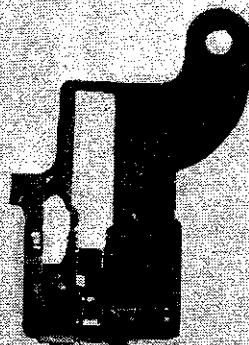

137-132
137-134
137-141

405-394-8 LIGHT & MEDIUM
405-395-1 HEAVY
405-529 EXTRA HEAVY

PLATE 23

MODEL 150-6

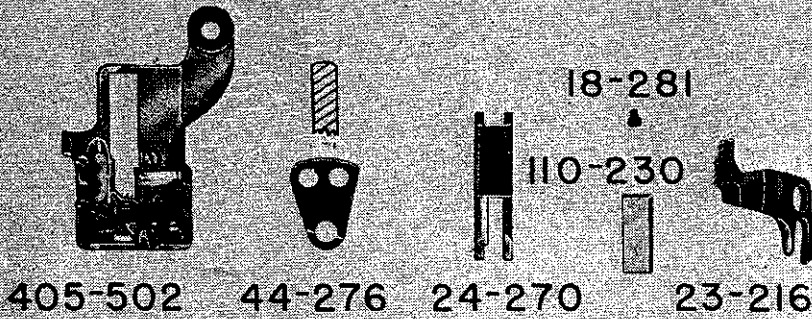

MODEL 150-6TS ONLY

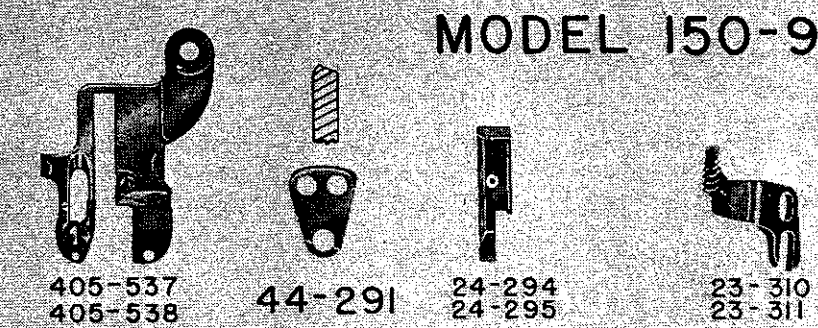
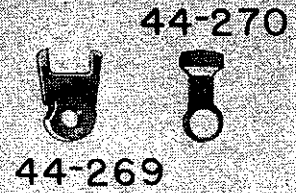

MODEL 150-9

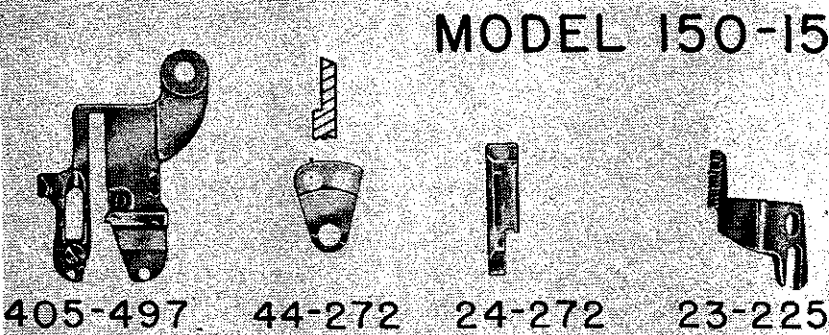
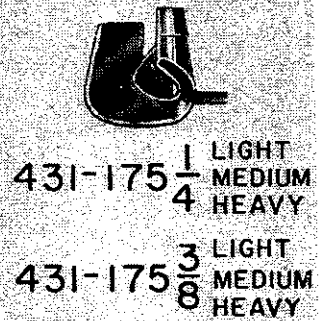

MODEL 150-15

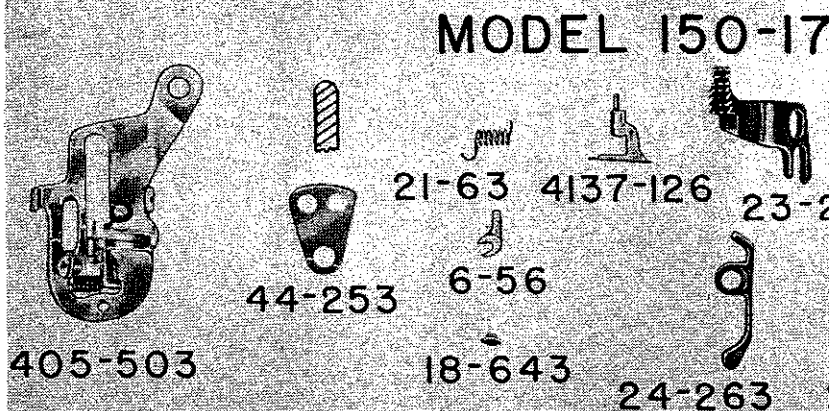
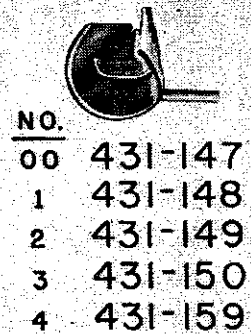

MODEL 150-17

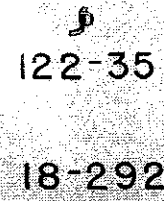

MODEL 150-16

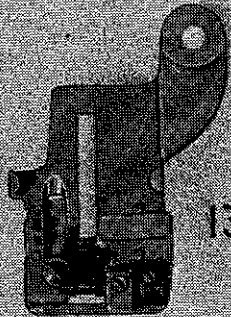

137-139



110-295



6-56



137-131

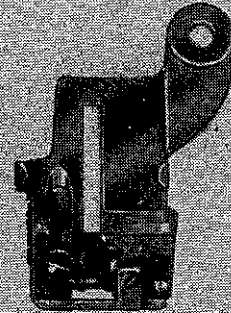

18-657

18-416

405-517

18-270

21-193

17-87

16-214

405-518

5/16 LOOP PARTS



110-294



63-30



110-238

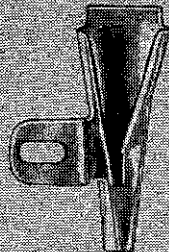

3/8 LOOP PARTS



63-29



110-293



110-234



8-125



110-237



8-124

431-169

431-170

431-171

431-172

FP539



8-123



110-236



8-122



18-38



110-285



119-70



119-68



119-69



18-957



24-278



24-277



23-31

PLUNGER PARTS



18-952



46-157



17-153

1022L



39-95



26-161



MODEL 150-7

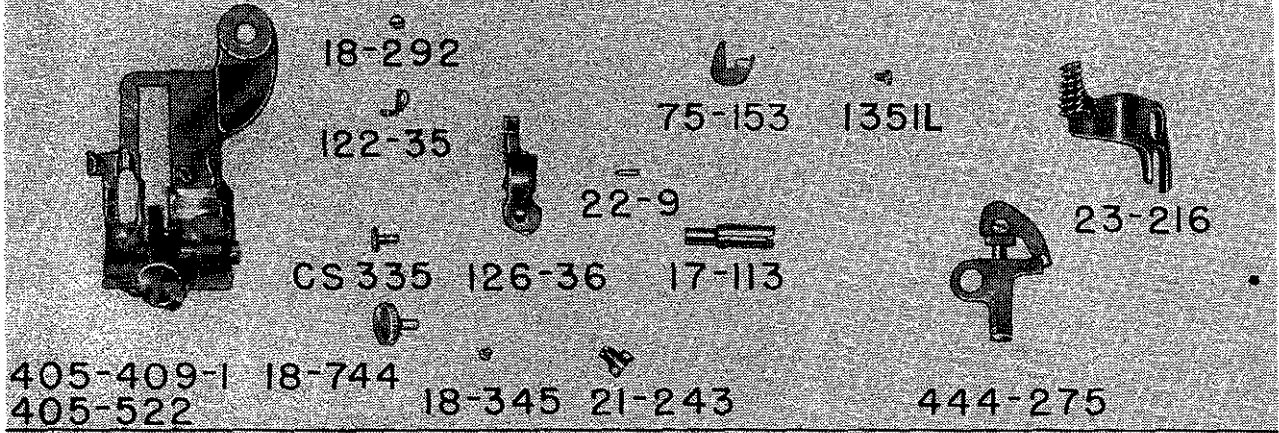

MODEL 150-23

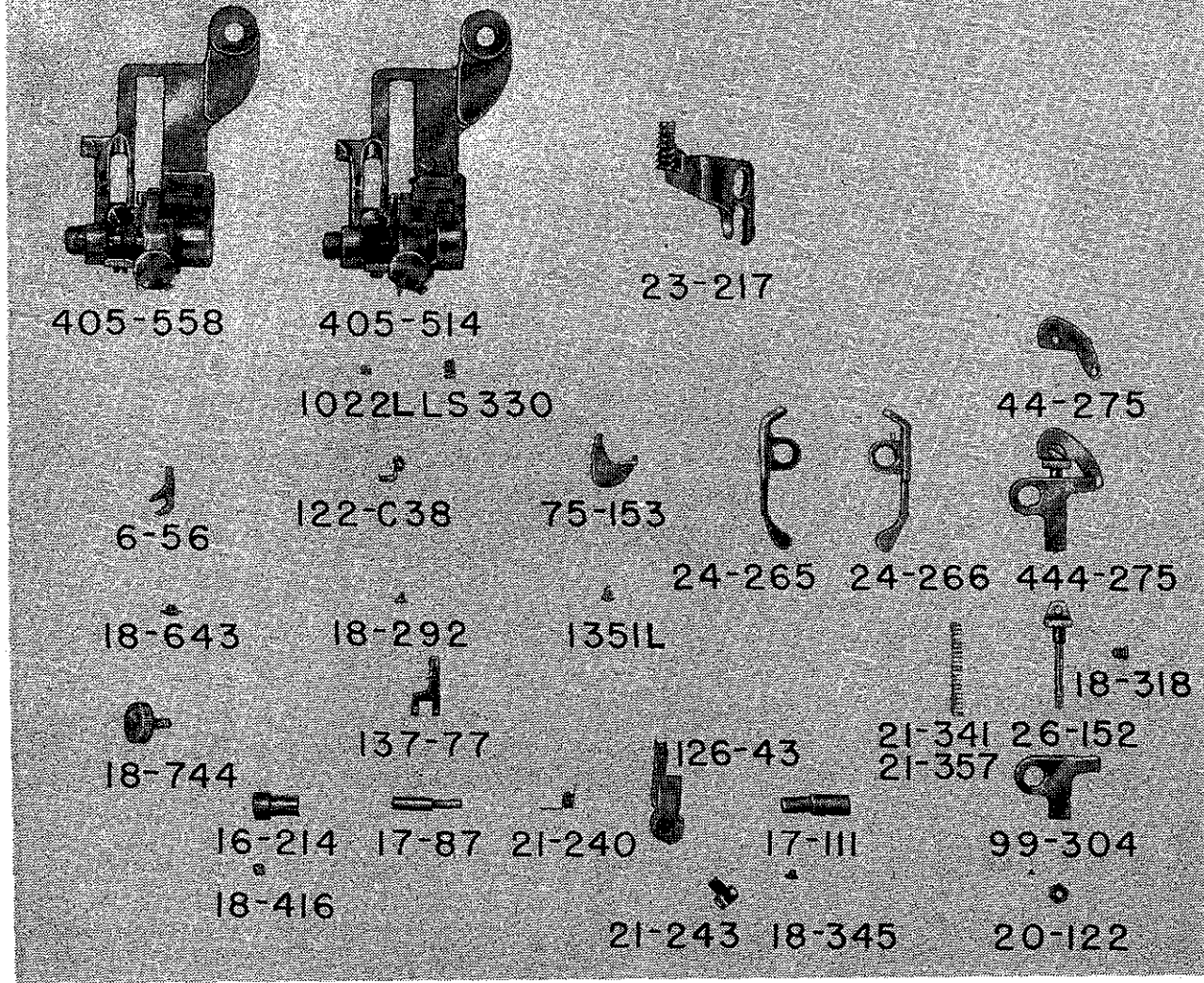

FEEDS

<u>Part No.</u>	<u>Plate</u>	<u>Description</u>
<u>MODELS 150-1, 5, 6, 6TS, AND 150-7</u>		
23-216	22	Padding, Felling, Hemming, Tacking and Fur Staying.
<u>MODEL 150-9</u>		
23-310	23	Bookseam, 1/4".
23-311	23	Bookseam, 3/8".
<u>MODEL 150-15</u>		
23-225	23	Rolled Edge.
<u>MODEL 150-16 AND 150-20</u>		
23-301	24	Belt Loops.
<u>MODEL 150-17</u>		
23-217	23	Padding Collars & Lapels.
<u>MODEL 150-23</u>		
Tacking Facing to Forepart (Bluff Edge)		
23-217	25	Medium and light work.

FEED PLATES

<u>Part No.</u>	<u>Plate</u>	<u>Description</u>
<u>MODELS 150-1, 5, AND 150-17</u>		
24-263	22	Left
24-264	22	Right
<u>MODELS 150-6 AND 150-6TS</u>		
24-270	23	
<u>MODELS 150-7 AND 150-23</u>		
24-265	25	Left
24-266	25	Right
<u>MODEL 150-9</u>		
24-294	23	1/4" seam
24-295	23	3/8" seam
<u>MODEL 150-15</u>		
24-272	23	
<u>MODEL 150-16</u>		
24-277	16, 24	Right
24-278	16, 24	Left
<u>MODEL 150-20</u>		
24-300	*	

FEED PLATE HOLDERS

<u>Part No.</u>	<u>Plate</u>	<u>Description</u>
<u>MODEL 150-1, 5 AND 150-17</u>		
499-298	5	Holder for Right Hand Feed Plate
499-298-1	5	Holder for Left Hand Feed Plate
<u>MODELS 150-6 AND 150-6TS</u>		
499-299	10, 11	Holder for Feed Plate
<u>MODELS 150-7 AND 150-23</u>		
499-303	12, 18	Holder for Right and Left Hand Feed Plates, (2) used
<u>MODEL 150-9</u>		
499-298	13	Holder, Right Hand, for Feed Plate
499-302	13	Holder, Left Hand, for Feed Plate
<u>MODEL 150-15</u>		
499-298	14	Holder for Right Hand Feed Plate
499-302	14	Holder for Left Hand Feed Plate
<u>MODEL 150-16</u>		
499-298	16	Holder for Right Hand Feed Plate
499-307	16	Holder for Left Hand Feed Plate
<u>MODEL 150-20</u>		
499-302	*	Holder for Feed Plate

FOLDERS

<u>Part No.</u>	<u>Plate</u>	<u>Description</u>
<u>MODEL 150-9 BOOKSEAM</u>		
431-L175 3/16	23	Light.
431-M175 3/16	23	Medium.
431-175 3/16H	23	Heavy.
431-L175 1/4	23	Light.
431-M175 1/4	23	Medium.
431-H175 1/4	23	Heavy.
431-175 5/16L	23	Light.
431-175 5/16M	23	Medium.
431-175 5/16H	23	Heavy.
431-L175 3/8	23	Light.
431-M175 3/8	23	Medium.
431-H175 3/8	23	Heavy.
<u>MODEL 150-15 ROLLED EDGE</u>		
431-147	23	#00 Extra Light Material.
431-148	23	#1 Light Material.
431-149	23	#2 Medium Material.
431-150	23	#3 Heavy Material.
431-159	23	#4 Extra Heavy Material.
<u>MODEL 150-16 BELT LOOPS</u>		
431-169	16, 24	5/16" Light to Medium Material.
431-170	16, 24	5/16" Medium to Heavy Material.
431-171	16, 24	3/8" Light to Medium Material.
431-172	16, 24	3/8" Medium to Heavy Material.
<u>MODEL 150-20 BELT LOOPS</u>		
431-M180 3/8	16	3/8" Material.
431-M180 5/16	16	5/16" Material.

PRESSER FEET

<u>Part No.</u>	<u>Plate</u>	<u>Description</u>
<u>MODEL 150-1</u>		
405-393-2	22	Light.
405-394-4	22	Medium (Standard).
405-395-1	22	Heavy.
405-419	22	Hemming Knit Materials.
405-508	22	Tropicals & Rayons.
<u>MODEL 150-5</u>		
405-394-8	22	Light & Medium Pants Bottoms (Standard).
405-395-1	22	Heavy Pants Bottoms.
405-529	22	Extra Heavy Pants Bottoms.
<u>MODELS 150-6 AND 150-6TS</u>		
405-502	23	Light, Medium and Heavy.
<u>MODEL 150-7</u>		
405-409-1	25	Fur Staying and Tacking, Light, Medium and Heavy.
405-522	25	Extra Heavy.
<u>MODEL 150-9</u>		
405-537	23	1/4" Bookseam.
405-538	23	3/8" Bookseam.
<u>MODEL 150-15</u>		
405-497	23	Rolled Edge.
<u>MODEL 150-16</u>		
Belt Loops.		
405-517	24	For Light to Medium Material.
405-518	24	For Medium to Heavy Material.

PRESSER FEET

<u>Part No.</u>	<u>Plate</u>	<u>Description</u>
		<u>MODEL 150-17</u>
405-503	23	Padding Collars and Lapels.
		<u>MODEL 150-20</u>
405-560	*	Belt Loops.
		<u>MODEL 150-23</u>
405-514	25	Light and Medium (Standard).
405-558	25	Heavy.

RIDGE FORMING DISC

<u>Part No.</u>	<u>Plate</u>	<u>Description</u>
<u>MODEL 150-1</u>		
44-253	22	Standard-General Work, Padding, Taping and Felling.
44-277	22	Tropicals and Rayons.
44-278	22	Hemming Knit Materials.
44-287	*	Extra Heavy Work.
<u>MODEL 150-5</u>		
44-253	*	Pants Bottoms, Heavy.
44-296	22	Pants Bottoms, Light and Medium (Std.).
<u>MODEL 150-6</u>		
44-276	23	Roll Padding.
<u>MODEL 150-6TS</u>		
44-269	23	Roll Padding & Through Stitch.
44-270	23	Roll Padding & Through Stitch.
<u>MODELS 150-7 AND 150-23</u>		
444-275	25	Fur Staying, Tacking and Bluff Edge.
<u>MODEL 150-9</u>		
44-291	23	Bookseam.
<u>MODEL 150-15</u>		
44-272	23	Rolled Edge Hemming.
<u>MODEL 150-16</u>		
26-160	24	(Plunger) Belt Loops.
<u>MODEL 150-17</u>		
44-253	23	Padding Collars and Lapels.
<u>MODEL 150-20</u>		
26-160	24	(Plunger) Belt Loops.

