

MODEL : SC-810

List No : 1473-01

# PARTS LIST

Published:09/10/2017

## CONTENTS

---

SC-810.....	1
HOW TO MAKE USE OF THIS PARTS LIST .....	5



SC-810

No.	Parts No.	Parts name	Remarks	Level	Cons	Qty
1	40051422	PSC UNIT 1PHASE 200-240V PFL				1
2	40050386	CTL_PCB_ASSY		*		1
3	40072352	PWR PCB ASSY		*		1
4	40051433	PEDAL_SENSEN_B_ASSY		*		1
5	40051429	SENSOR COIL HOLD B ASSY		*		1
6	40051446	SENSOR COIL B		*		1
7	40042136	COIL_BASE		*		1
8	40052809	NYLON_RIVET		*		2
9	EA9500B0100	CABLE BAND		*		1
10	40042130	PEDAL_SENSOR_BASE		*		1
11	40042131	PEDAL_LEVER		*		1
12	40042133	PEDAL_LEVER_B		*		1
13	40006202	ADJUST_NUT		*		2
14	40006207	FRONT_SPRING		*		1
15	40006208	SPRING_SHAFT_A		*		2
16	40049426	SPRING_C		*		2
17	40006212	ADJUST_SCREW		*		2
18	SM8040612TP	SCREW M4 L=6		*		2
19	SV4030601SR	SCREW M3 L=6		*		2
20	40016469	DC POWER SUPPLY CORD ASSY		*		1
21	40030709	RESISTANCE ASSY		*		1
22	40072029	LAMBDA GEL SHEET 35-50		*		1
23	40042122	CONNECTOR_COVER		*		1
24	40042123	FRONT_COVER		*		1
25	40042124	REAR_COVER		*		1
26	40042125	BOX_BRACKET_L		*		1
27	40042126	BOX_BRACKET_R		*		1
28	40042127	FRAME		*		1
29	40042128	HOUSING_PLATE		*		1
30	40043342	KEY_TOP		*		1
31	40042137	LED_COVER		*		1
32	KX000000280	BEAD BAND		*		2
33	KX000000220	LOCKING CIRCUIT BOARD SUPPORT		*		1
34	40051437	RATING_LABEL_B_DRAWING		*		1
35	SL4041081SC	SCREW M4 L=10		*		5
36	SL4041081SC	SCREW M4 L=10		*		14
37	M1013110000	CORD BUSH A		*		1
38	SL4041091SC	SCREW M4 L=10		*		1
39	SL4041081SC	SCREW M4 L=10		*		2
40	SL4041491SC	SCREW 4 X 14		*		2
41	SL4041691SC	SCREW M4 L=16		*		2
42	SL4041491SC	SCREW 4 X 14		*		3
43	SL4041091SE	SCREW M4 L=10		*		3
44	SL9081693SE	HEXAGON SCREW WITH WASHER		*		4
45	CM300400701	VOLTAGE CAUTION LABEL		*		1
46	CM300100001	LABEL		*		1
47	M4401471AA0	BOX ACCESSORIE PART A ASM.				1

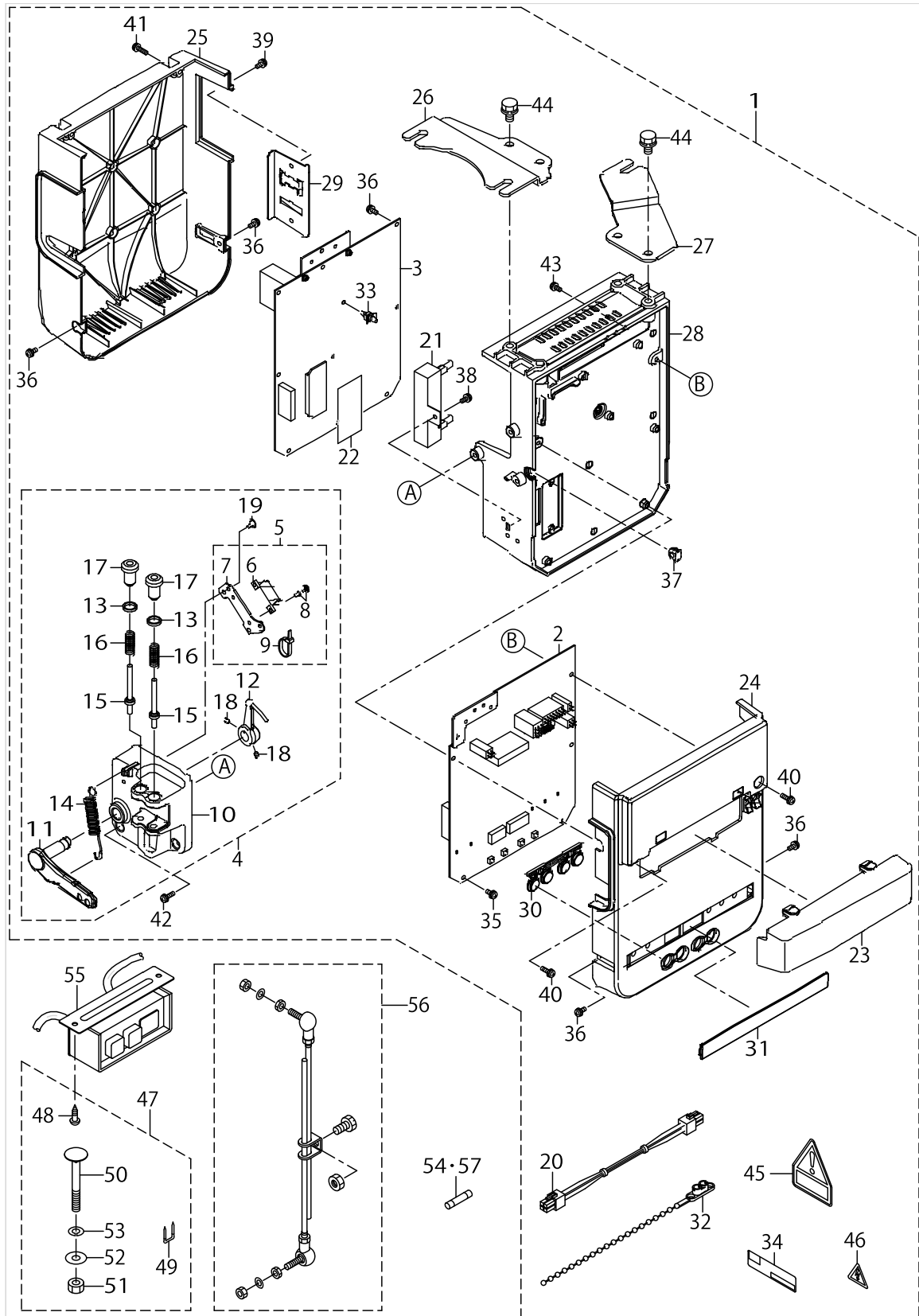

## SC-810

No.	Parts No.	Parts name	Remarks	Level	Cons	Qty
48	SK3512001SE	WOOD SCREW D=5.1 L=20		*		2
49	MAO11532000	CORD STAPLE		*		5
50	MTSHJ100003	BOLT		*		3
51	NM6080002SC	NUT M8		*		3
52	WP0851846SC	WASHER 8.5X22.0X1.8		*		3
53	WS0820002KR	SPRING WASHER, M8		*		3
54	KF000000030	SLO-BLO FUSE				1
55	40051434	AC_POWER_SUPPLY_CORD_A				1
56	40042134	CONNECING_ROD_ASSY				1
57	KF000000080	SLO-BLO FUSE				1

## HOW TO MAKE USE OF THIS PARTS LIST

1.As to "#01" and "#02" refer to the "Note" given at the bottom of the respective pages.

2.Codes on the "Qty" column

- Each numeral indicates the number of parts required.
- "0.1" and "2.5" indicate the length (in meters) of the respective parts.

3.Parentheses mean that the corresponding part is a subpart that constructs an assembly part.

4.Dotted lines on the Figures indicate assembly parts.

1. リストページの# 0 1、# 0 2の印は、ページ下の"注記"の説明を参照下さい。
2. 数量欄の数字は、個数を表し、0. 1、2. 5等の数値は、長さ（単位メートル）を表します。
3. 数量欄の（ ）は、組部品を構成している子部品であることを意味します。
4. イラストページの-----枠は、組構成であることを意味します。

NUMERICAL INDEX OF PARTS

PART NO	PAGE	REF NO.	PART NO	PAGE	REF NO.
40006202	2	13	SL4041091SC	2	38
40006207	2	14	SL4041091SE	2	43
40006208	2	15	SL4041491SC	2	42
40006212	2	17	SL4041691SC	2	41
40016469	2	20	SL9081693SE	2	44
40030709	2	21	SM8040612TP	2	18
40042122	2	23	SV4030601SR	2	19
40042123	2	24	WP0851846SC	4	52
40042124	2	25	WS0820002KR	4	53
40042125	2	26			
40042126	2	27			
40042127	2	28			
40042128	2	29			
40042130	2	10			
40042131	2	11			
40042133	2	12			
40042134	4	56			
40042136	2	7			
40042137	2	31			
40043342	2	30			
40049426	2	16			
40050386	2	2			
40051422	2	1			
40051429	2	5			
40051433	2	4			
40051434	4	55			
40051437	2	34			
40051446	2	6			
40052809	2	8			
40072029	2	22			
40072352	2	3			
CM300100001	2	46			
CM300400701	2	45			
EA9500B0100	2	9			
KF000000030	4	54·57			
KF000000080	4	54·57			
KX000000220	2	33			
KX000000280	2	32			
M1013110000	2	37			
M4401471AA0	2	47			
MAO11532000	4	49			
MTSHJ100003	4	50			
NM6080002SC	4	51			
SK3512001SE	4	48			
SL4041081SC	2	39			