

MODEL : FU-05
List No : 1448-05

PARTS LIST

Published:09/10/2017

CONTENTS

TUAN AROUND MECHANISM COMPONENTS (1).....	1
TUAN AROUND MECHANISM COMPONENTS (2).....	3
PNEUMATIC COMPONENTS	5
HOW TO MAKE USE OF THIS PARTS LIST	7

TUAN AROUND MECHANISM COMPONENTS (1)

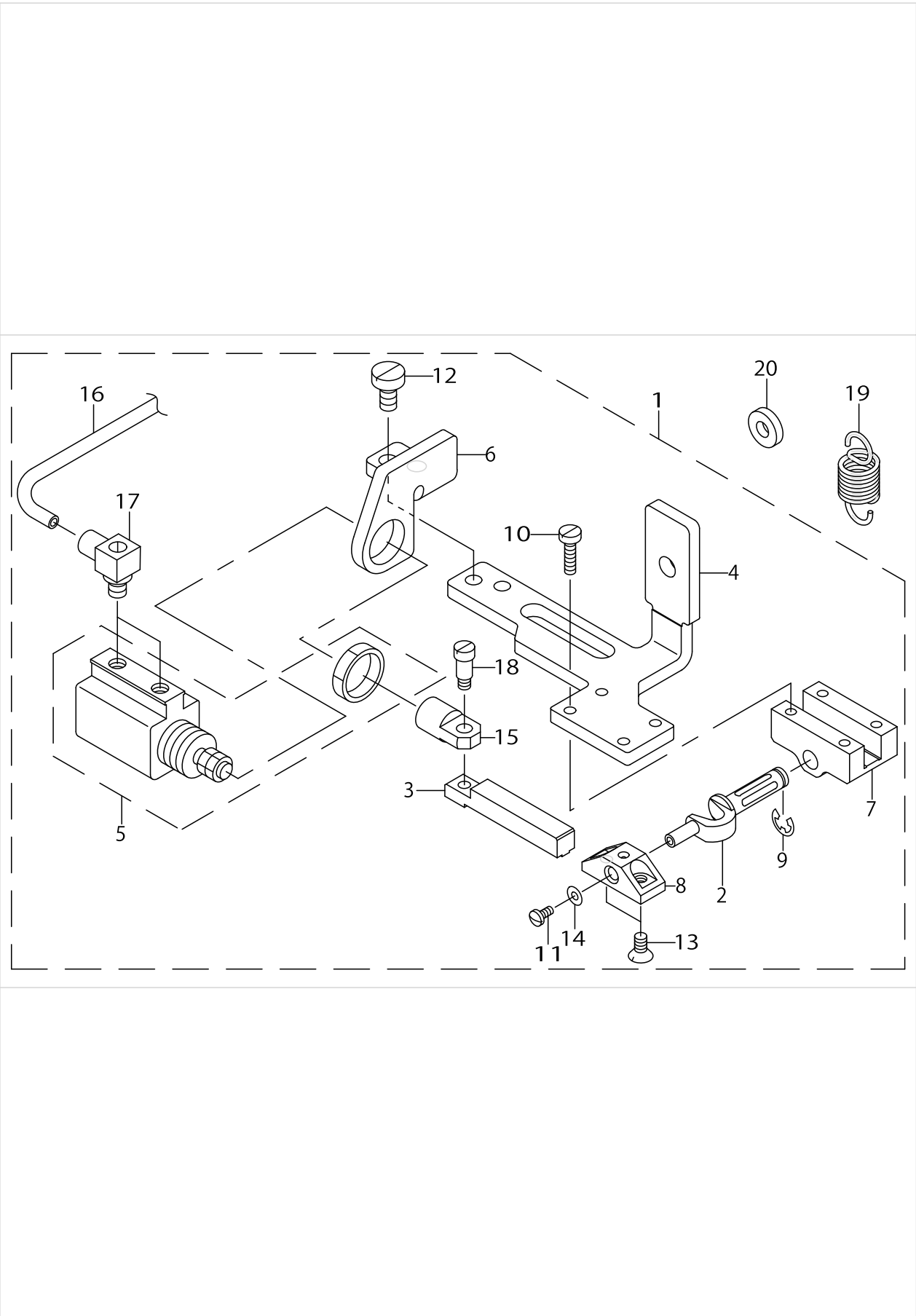

TUAN AROUND MECHANISM COMPONENTS (1)

No.	Parts No.	Parts name	Remarks	Level	Cons	Qty
1	GFU010030A0	SLIDE PLATE ASM.				1
2	GFU01001000	TURN AROUND CRANK SHAFT		*		1
3	GFU01002000	INVERTING LAC		*		1
4	GFU01003000	INNER PRESSER SLIDE PLATE		*		1
5	PA1600801A0	AIR CYLINDER		*		1
6	GFU01006000	TURN CYLINDER BRACKET		*		1
7	B4303210000	TURN AROUND CRANK BEARING		*		1
8	B4314210000	INTERMEDIATE PRESSER BASE		*		1
9	RE0400000K0	E-RING 4		*		1
10	SS6081210SP	SCREW 1/8-44 L=12		*		4
11	SS7060610SP	SCREW 3/32-56 L= 5.5		*		1
12	SS6120940SP	SCREW 3/16-28 L=9		*		2
13	SS1090750SP	SCREW 9/64-40 L=7		*		2
14	WP0250516SD	WASHER 2.5X6X0.5		*		1
15	B4306220000	KNUCKLE		*		1
16	BT0400251EB	URETHANE HOSE, BLACK		*		1.3
17	PJ046052503	HOSE ELBOW		*		2
18	SD0460703TP	HINGE SCREW D=4.6 H=7		*		1
19	GFU01007000	SPRING				1
20	WP0502616SD	WASHER				1

TUAN AROUND MECHANISM COMPONENTS (2)

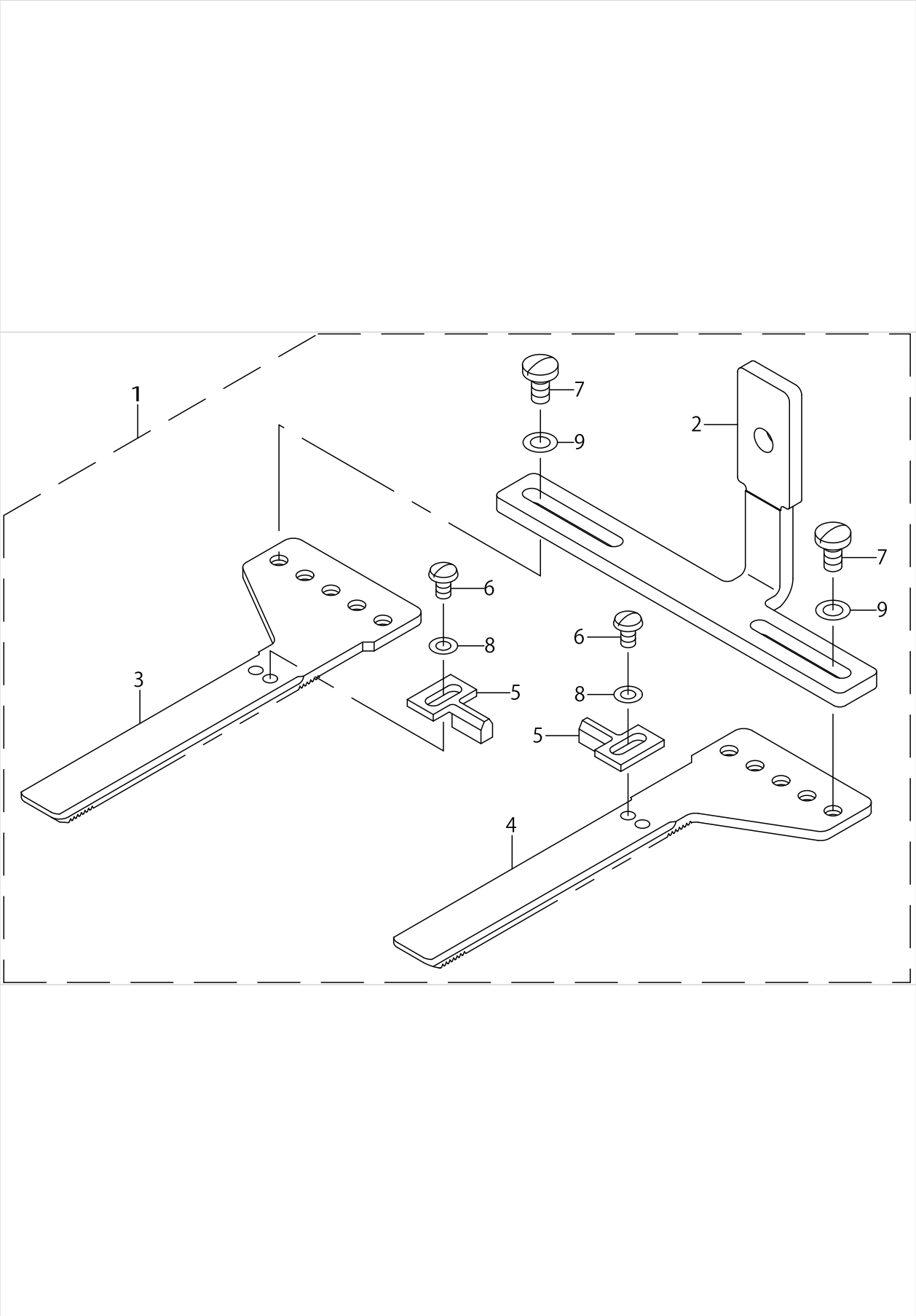

TUAN AROUND MECHANISM COMPONENTS (2)

No.	Parts No.	Parts name	Remarks	Level	Cons	Qty
1	GFU010040A0	OUTER PRESSER SLIDE PLATE ASM.				1
2	GFU01004000	OUTER PRESSER SLIDE PLATE		*		1
3	D255121XX00	WALKING FOOT (A)		*		1
4	D255221XX00	WALKING FOOT (B)		*		1
5	D255421XX00	COMPENSATING FOOT		*		2
6	SS5090610SP	SCREW 9/64-40 L=6		*		2
7	SS7110840SP	SCREW 11/64-40 L=7.8		*		4
8	WP0371026SD	WASHER 3.7X7X1		*		2
9	WP0480856SP	WASHER 4.8X8.4X0.8		*		4

PNEUMATIC COMPONENTS

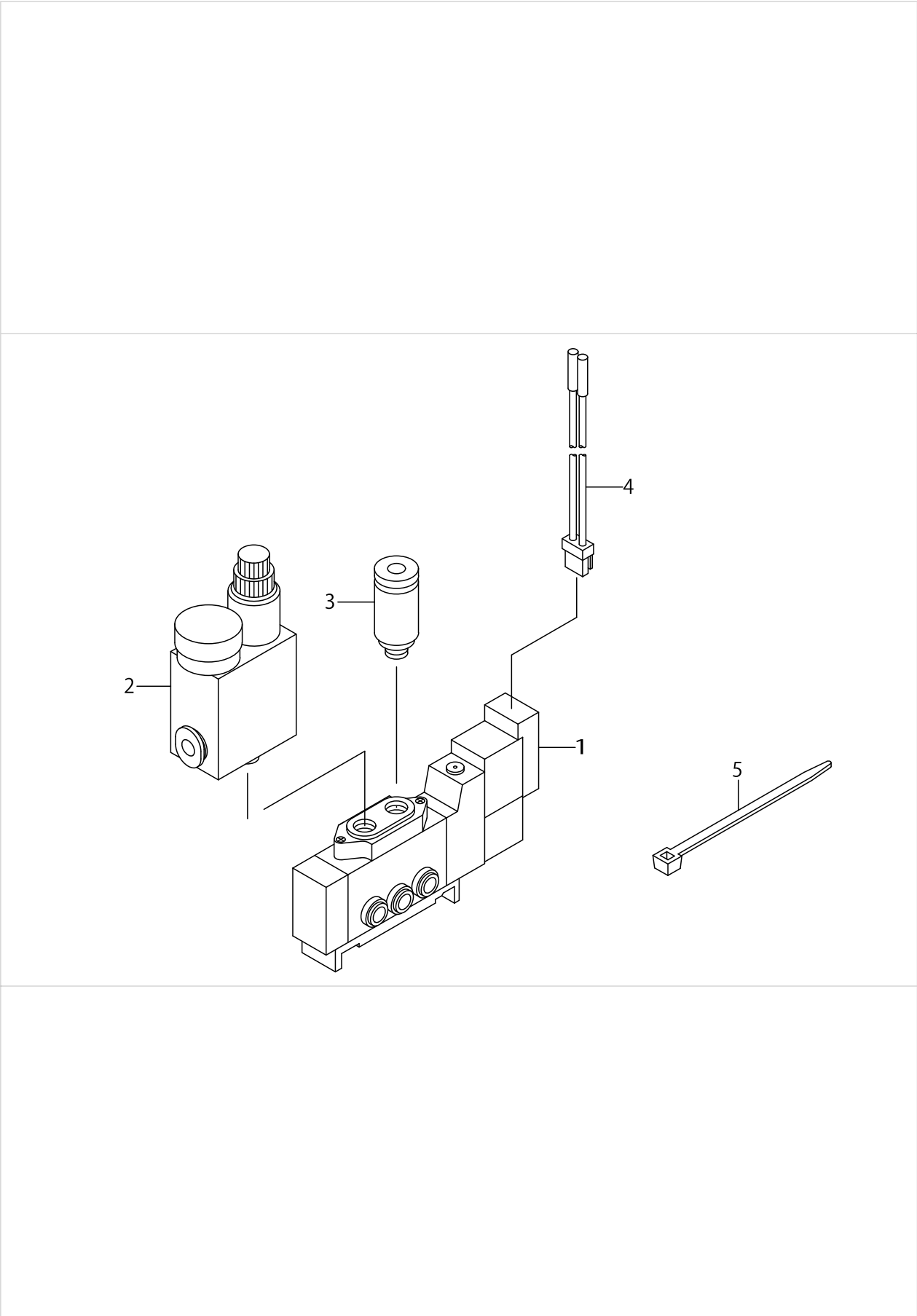

PNEUMATIC COMPONENTS

No.	Parts No.	Parts name	Remarks	Level	Cons	Qty
1	PV150209100	SOLENOID VALVE				1
2	PF0205030A0	REGULATOR				1
3	PJ301040505	HALF UNION	FOR S TYPE, USE 2 PCS. FOR L TY- PE, USE 1 PCS.			2
4	40035324	SOLENOID VALVE CONNECTER ASM.				1
5	EA9500B0100	CABLE BAND				3

HOW TO MAKE USE OF THIS PARTS LIST

1.As to "#01" and "#02" refer to the "Note" given at the bottom of the respective pages.

2.Codes on the "Qty" column

- Each numeral indicates the number of parts required.
- "0.1" and "2.5" indicate the length (in meters) of the respective parts.

3.Parentheses mean that the corresponding part is a subpart that constructs an assembly part.

4.Dotted lines on the Figures indicate assembly parts.

1. リストページの# 0 1、# 0 2の印は、ページ下の"注記"の説明を参照下さい。
2. 数量欄の数字は、個数を表し、0. 1、2. 5等の数値は、長さ（単位メートル）を表します。
3. 数量欄の（ ）は、組部品を構成している子部品であることを意味します。
4. イラストページの-----枠は、組構成であることを意味します。

NUMERICAL INDEX OF PARTS

PART NO	PAGE	REF NO.
40035324	6	4
B4303210000	2	7
B4306220000	2	15
B4314210000	2	8
BT0400251EB	2	16
D255121XX00	4	3
D255221XX00	4	4
D255421XX00	4	5
EA9500B0100	6	5
GFU01001000	2	2
GFU01002000	2	3
GFU01003000	2	4
GFU010030A0	2	1
GFU01004000	4	2
GFU010040A0	4	1
GFU01006000	2	6
GFU01007000	2	19
PA1600801A0	2	5
PF0205030A0	6	2
PJ046052503	2	17
PJ301040505	6	3
PV150209100	6	1
RE0400000K0	2	9
SD0460703TP	2	18
SS1090750SP	2	13
SS5090610SP	4	6
SS6081210SP	2	10
SS6120940SP	2	12
SS7060610SP	2	11
SS7110840SP	4	7
WP0250516SD	2	14
WP0371026SD	4	8
WP0480856SP	4	9
WP0502616SD	2	20