

MODEL : TC-13

List No : 1396-03

PARTS LIST

Published:09/10/2017

CONTENTS

TAPE CUTTER COMPONENTS	1
CONTROL BOX COMPONENTS	5
HOW TO MAKE USE OF THIS PARTS LIST	7

TAPE CUTTER COMPONENTS

	PARTS NO		NOTE	注記
	FOR C10	FOR E10		
TC13A	400-28805	400-28808	WITH CONTROL BOX(FOR 220~440V)	電装ボックス付 (220~440V用)
TC13B	400-28806	400-28809	WITH CONTROL BOX(FOR 100~240V)	電装ボックス付 (100~240V用)
TC13C	400-28807	400-28810	SEAVO MOTOR TYPE(FOR SC510)	サーボモータ仕様(SC510用)

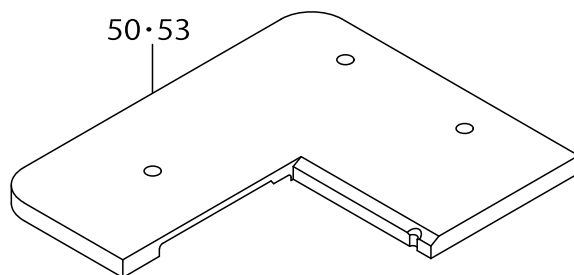
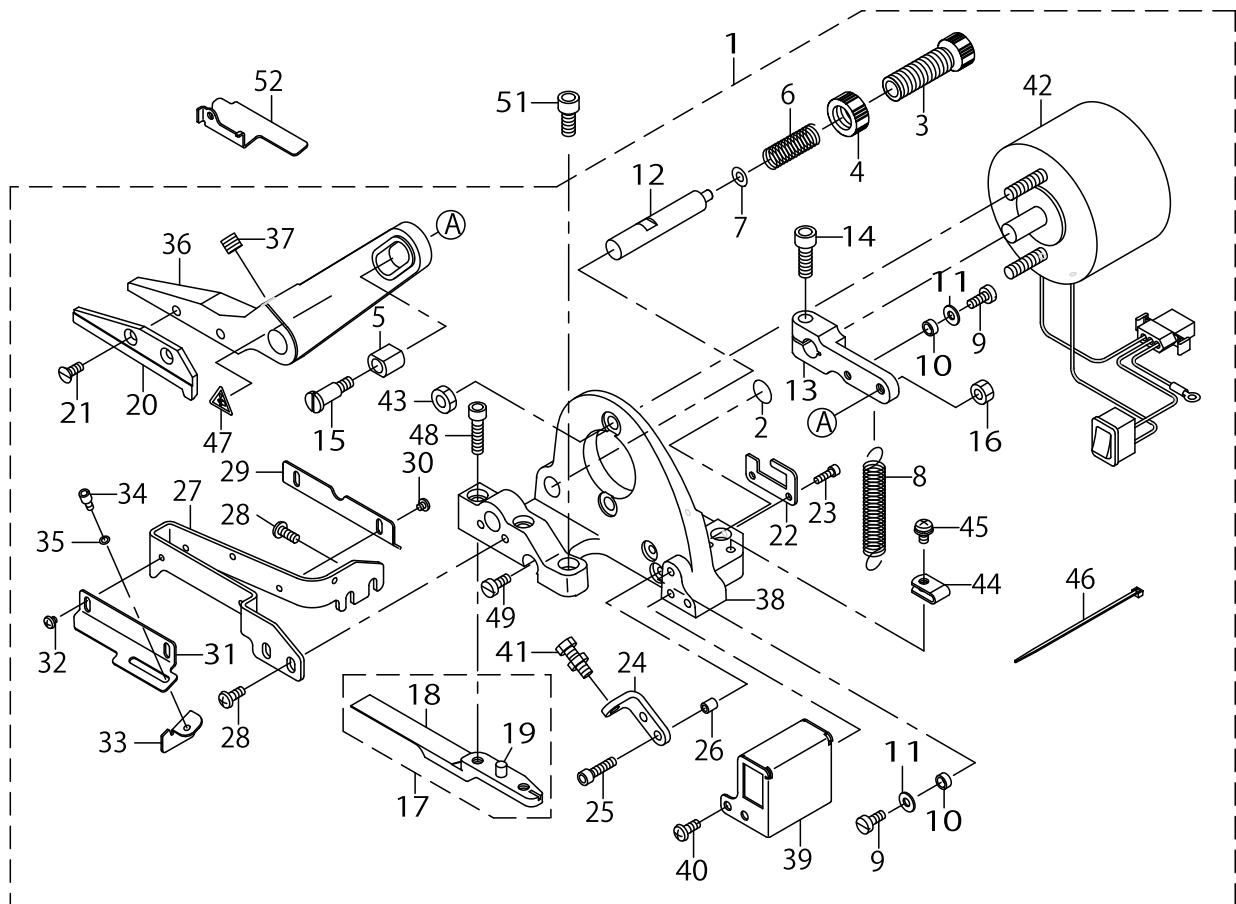

TAPE CUTTER COMPONENTS

No.	Parts No.	Parts name	Remarks	Level	Cons	Qty
1	40043920	MG TAPE CUTTER ASM.				1
2	22901805	GROUND MARK		*		1
3	40011179	PRESSER SPRING REGULATOR		*		1
4	40011180	NUT		*		1
5	40019878	TC_SLIDE_BLOCK		*		1
6	40019879	TC_SPRING_A		*		1
7	WP0480856SP	WASHER 4.8X8.4X0.8		*		1
8	40019880	TC_SPRING_B		*		1
9	SM6041050TP	SCREW M4 L=10		*		2
10	B1650210000	DRIVING LINK ROLLER.		*		2
11	14030100	WASHER		*		2
12	40019881	TC_SHAFT		*		1
13	40019882	TC_SOLENOID_LEVER		*		1
14	SM6061802TP	SCREW M6 L=18		*		1
15	SD0701206TP	SHOULDER SCREW D=7 H=12		*		1
16	NM6050001SC	NUT M5		*		1
17	40020224	TC_FIXED_KNIFE_ASM		*		1
18	40019883	TC_FIXED_KNIFE		*		1
19	12219705	PIN		*		1
20	40019884	TC_MOVING_KNIFE		*		1
21	SM1041000SP	SCREW M4 L=10		*		2
22	40044022	TC CONNECTOR BKT		*		1
23	SM6031002TP	HEXAGONAL BOLT M3 X 10		*		2
24	40019886	TC_STOPPER_BKT		*		1
25	SM6041602TP	SCREW M4X0.7 L=16		*		2
26	B3028450000	ROLLER		*		2
27	40019887	TC_COVER_A		*		1
28	SM5041055SN	SCREW M4X10		*		4
29	40019888	TC_COVER_B		*		1
30	SM5030355SE	SCREW		*		2
31	40019889	TC_GUIDE_A		*		1
32	SM5030355SE	SCREW		*		2
33	40019890	TC_GUIDE_B		*		1
34	SM6030502TP	BOLT M3X5		*		1
35	WP0320500SC	WASHER M3		*		1
36	40019891	TC_LEVER		*		1
37	SM8060812TP	SCREW M6 L=8		*		1
38	40019892	TC_BASE		*		1
39	40019894	TC_SWITCH_BOX		*		1
40	SM5041055SN	SCREW M4X10		*		2
41	40040451	TC STOPPER BOLT ASM.		*		1
42	40042219	TC SOLENOID ASSY		*		1
43	NM6060001SC	NUT M6		*		2
44	HX001500000	CLIP		*		1
45	SM5041055SN	SCREW M4X10		*		2
46	EA9500B0100	CABLE BAND		*		1
47	CM300200001	ATTENTION SEAL		*		2

TAPE CUTTER COMPONENTS

	PARTS NO		NOTE	注記
	FOR C10	FOR E10		
TC13A	400-28805	400-28808	WITH CONTROL BOX(FOR 220~440V)	電装ボックス付 (220~440V用)
TC13B	400-28806	400-28809	WITH CONTROL BOX(FOR 100~240V)	電装ボックス付 (100~240V用)
TC13C	400-28807	400-28810	SEAVO MOTOR TYPE(FOR SC510)	サーボモータ仕様(SC510用)

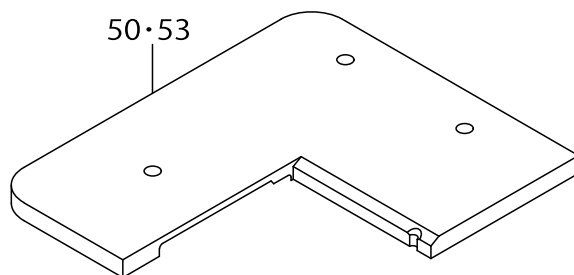
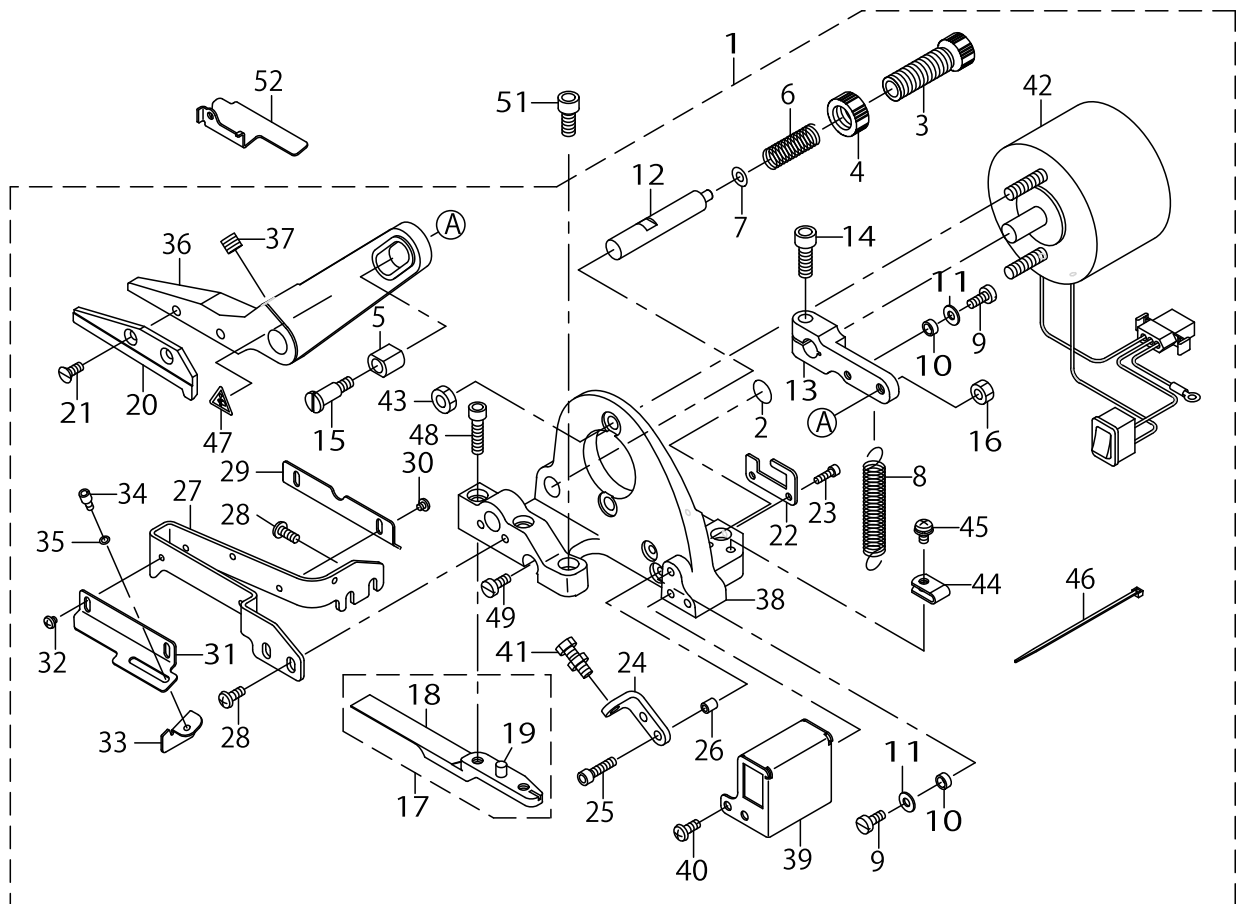

TAPE CUTTER COMPONENTS

No.	Parts No.	Parts name	Remarks	Level	Cons	Qty
48	SM6052002TP	SCREW M5 L=20		*		2
49	SM6041050TP	SCREW		*		1
50	40042602	ASSY_CLOTH_PLATE_LEFT_TC	FOR E10			1
51	SM6051402TP	SCREW M5X0.8 L=14				2
52	40019893	TC_TAPE_GUIDE				1
53	40019895	TC_CLOTH_PLATE_ASM.	FOR C10			1

CONTROL BOX COMPONENTS

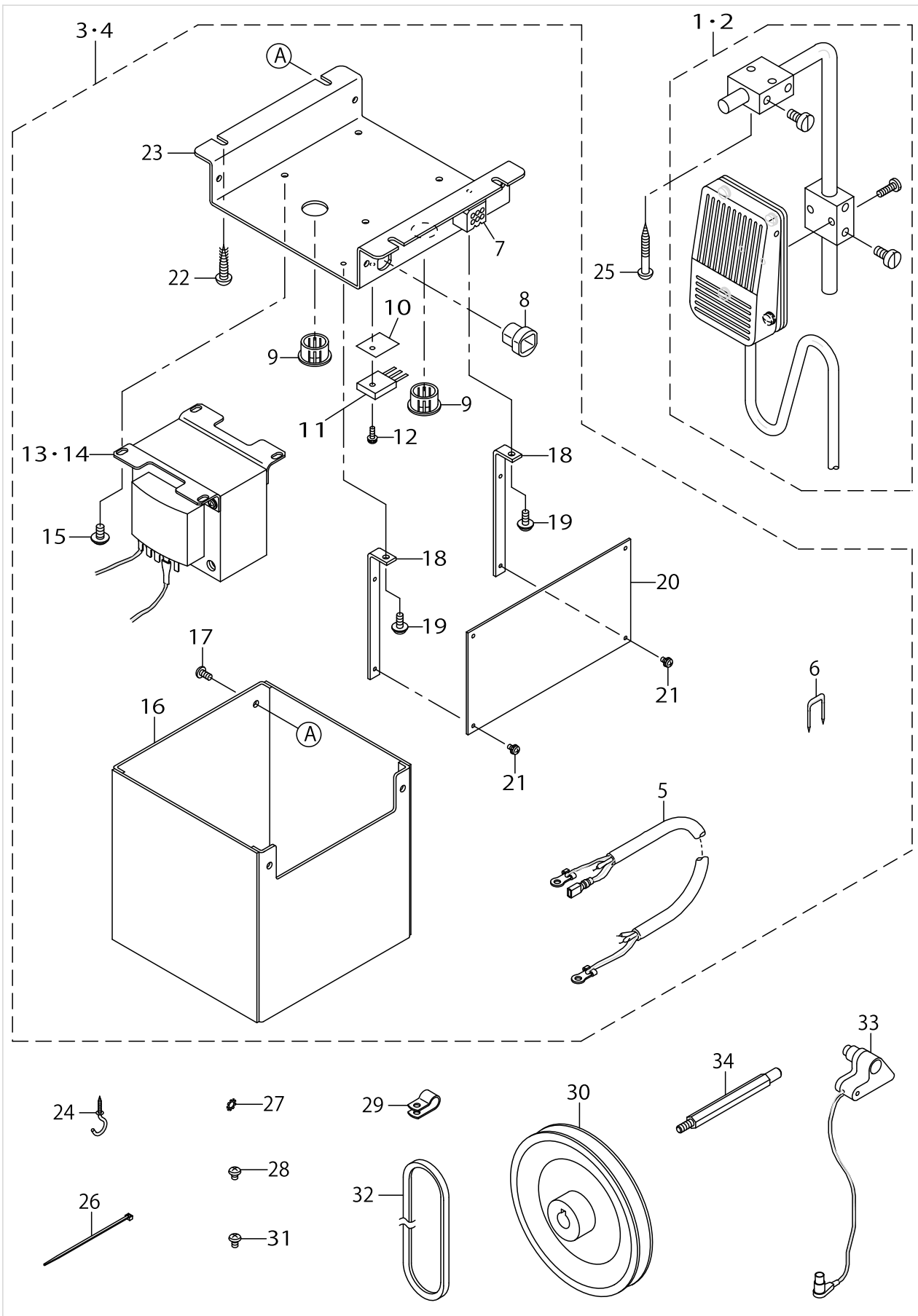

CONTROL BOX COMPONENTS

No.	Parts No.	Parts name	Remarks	Level	Cons	Qty
1	40042221	TC SWITCH B ASSY	FOR TC13A,TC13B			1
2	40049440	TC SWITCH C ASSY	FOR TC13C			1
3	40039579	T006 CONTROL BOX A ASSY	FOR TC13A(220~440V)			1
4	40039580	T006 CONTROL BOX B ASSY	FOR TC13B(100~240V)			1
5	MAT006050A0	POWER SOURCE CORD ASM.		*		1
6	MAO11532000	CORD STAPLE		*		4
7	40039585	CONNECTOR ASSY		*		1
8	HX000210000	CORD BUSHING		*		1
9	HX002270000	ONE TOUCH BUSH		*		2
10	HX001970000	INSULATE PLATE		*		1
11	40039584	TRANSISTOR ASSY		*		1
12	SL4031081SC	SCREW M3 X 10		*		1
13	40039583	TRANSFORMER A ASSY	FOR TC13A(220~440V)	*		1
14	40039588	TRANSFORMER B ASSY	FOR TC13B(100~240V)	*		1
15	SL4040891SC	SCREW		*		4
16	MAT00616000	CONTROL UNIT COVER		*		1
17	SL4040891SC	SCREW M4 L=8		*		4
18	40039587	MCU PCB SUPPORT PLATE		*		2
19	SL4030881SC	SCREW		*		2
20	40039573	MCU PCB ASSY		*		1
21	SL4030681SC	SCREW M3 L=6		*		4
22	SK3482500SC	WOOD SCREW D=4.8 L=25		*		4
23	40039586	CONTROL BOX MOUNTING BASE		*		1
24	D2113555B00	CORD SET HOOK, B				2
25	SK3514000SC	WOOD SCREW D=5.1 L=40				2
26	EA9500B0100	CABLE BAND				2
27	WT0430002KN	WASHER M4	FOR TC13C			1
28	SM4040501SN	SCREW M4X0.7 L=5	FOR TC13C			1
29	HX00150000C	CABLE CLIP	FOR TC13C			1
30	MTSP0115000A	MOTOR PULLEY	FOR TC13C			1
31	SM4040655SP	SCREW M4 L=6	FOR TC13C			1
32	MTJVM003600	V-BELT, 36 INCH	FOR TC13C			1
33	40026920	SYNCHRONIZER ASM.	FOR TC13C			1
34	40023351	SYNCHRONIZER_STUD_ASSY	FOR TC13C			1

HOW TO MAKE USE OF THIS PARTS LIST

1.As to "#01" and "#02" refer to the "Note" given at the bottom of the respective pages.

2.Codes on the "Qty" column

- Each numeral indicates the number of parts required.
- "0.1" and "2.5" indicate the length (in meters) of the respective parts.

3.Parentheses mean that the corresponding part is a subpart that constructs an assembly part.

4.Dotted lines on the Figures indicate assembly parts.

1. リストページの# 0 1、# 0 2の印は、ページ下の"注記"の説明を参照下さい。
2. 数量欄の数字は、個数を表し、0. 1、2. 5等の数値は、長さ（単位メートル）を表します。
3. 数量欄の（ ）は、組部品を構成している子部品であることを意味します。
4. イラストページの-----枠は、組構成であることを意味します。

ALL PARTS NOT MENTIONED IN THIS PARTS LIST ARE SAME AS THOSE OF
MODEL MF-7700. OTHER PARTS LIST RELATED TO THIS MODEL.
*MF-7700 SERIES (NO.1375 PART NO.13370002)

このパーツリスト記載以外の部品はMF-7700と共通です。
この機種に関連するパーツリストとして下記のパーツリストがあります。
*MF-7700シリーズ（NO. 1375 品番13370002）

NUMERICAL INDEX OF PARTS

PART NO	PAGE	REF NO.	PART NO	PAGE	REF NO.
12219705	2	19	EA9500B0100	2	46
14030100	2	11	EA9500B0100	6	26
22901805	2	2	HX000210000	6	8
40011179	2	3	HX001500000	2	44
40011180	2	4	HX00150000C	6	29
40019878	2	5	HX001970000	6	10
40019879	2	6	HX002270000	6	9
40019880	2	8	MAO11532000	6	6
40019881	2	12	MAT006050A0	6	5
40019882	2	13	MAT00616000	6	16
40019883	2	18	MTJVM003600	6	32
40019884	2	20	MTSP0115000A	6	30
40019886	2	24	NM6050001SC	2	16
40019887	2	27	NM6060001SC	2	43
40019888	2	29	SD0701206TP	2	15
40019889	2	31	SK3482500SC	6	22
40019890	2	33	SK3514000SC	6	25
40019891	2	36	SL4030681SC	6	21
40019892	2	38	SL4030881SC	6	19
40019893	4	52	SL4031081SC	6	12
40019894	2	39	SL4040891SC	6	17
40019895	4	53	SM1041000SP	2	21
40020224	2	17	SM4040501SN	6	28
40023351	6	34	SM4040655SP	6	31
40026920	6	33	SM5030355SE	2	32
40039573	6	20	SM5041055SN	2	45
40039579	6	3-4	SM6030502TP	2	34
40039580	6	3-4	SM6031002TP	2	23
40039583	6	13-14	SM6041050TP	2	49
40039584	6	11	SM6041050TP	4	49
40039585	6	7	SM6041602TP	2	25
40039586	6	23	SM6051402TP	4	50-53
40039587	6	18	SM6052002TP	4	48
40039588	6	13-14	SM6061802TP	2	14
40040451	2	41	SM8060812TP	2	37
40042219	2	42	WP0320500SC	2	35
40042221	6	1-2	WP0480856SP	2	7
40042602	4	50-53	WT0430002KN	6	27
40043920	2	1			
40044022	2	22			
40049440	6	1-2			
B1650210000	2	10			
B3028450000	2	26			
CM300200001	2	47			
D2113555B00	6	24			