

MODEL : SC-500

List No : 1383-02

PARTS LIST

Published:09/10/2017

CONTENTS

PSC UNIT COMPONENTS	1
MOTOR COMPONENTS	5

PSC UNIT COMPONENTS

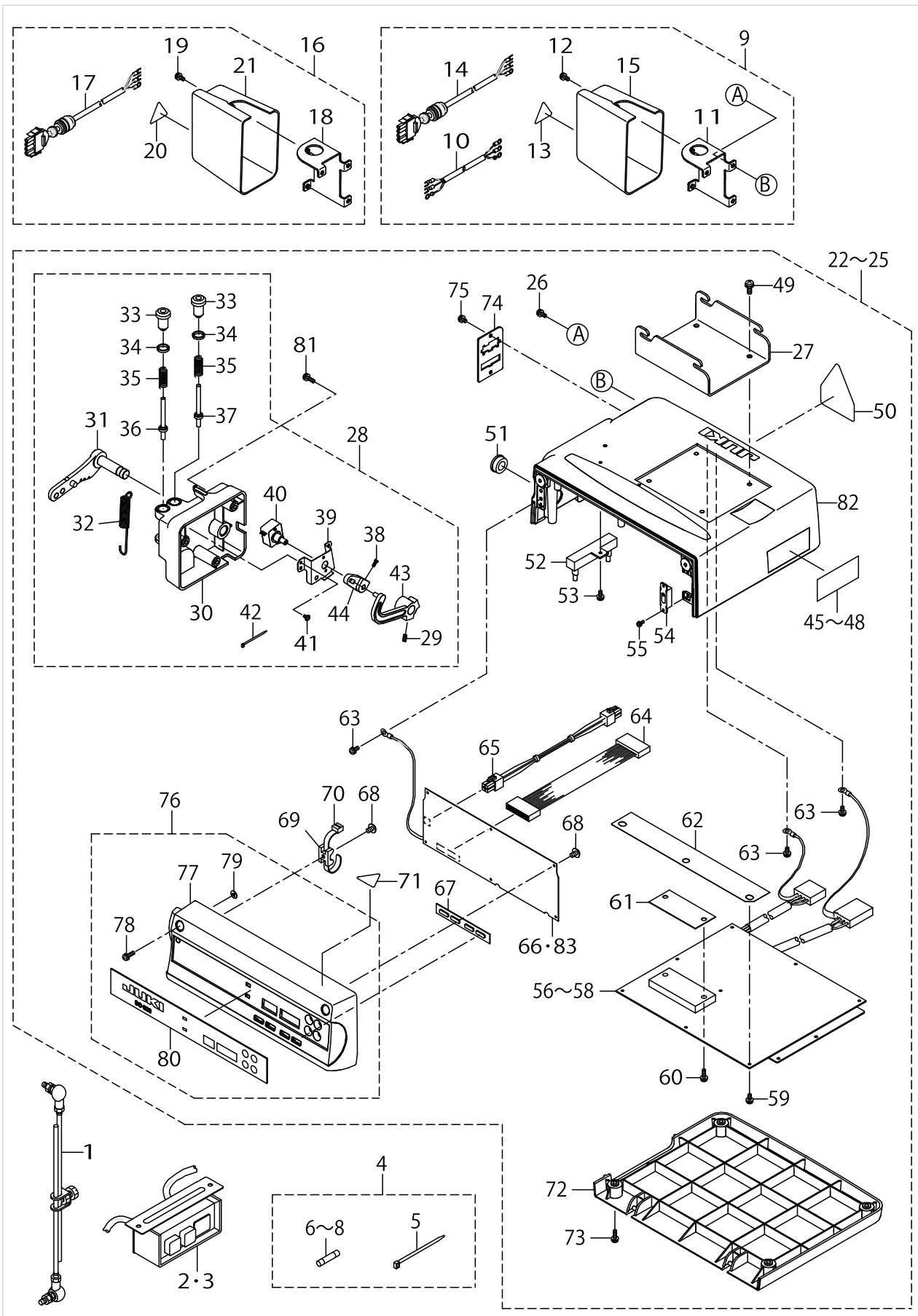

PSC UNIT COMPONENTS

No.	Parts No.	Parts name	Remarks	Level	Cons	Qty
1	M4501471AA0	CONNECTING ROD A ASM.				1
2	M6101471AA0	POWER SWITCH A ASM.	FOR 1 ϕ 110V/3 ϕ 220V JUS			1
3	M6101471CA0	POWER SWITCH C ASM.	FOR 1 ϕ 200~240V JS, 1 ϕ 200~240V CN			1
4	40016531	BOX ACCESSORIE PART ASSY				1
5	EA9500B0200	CABLE BAND 150		*		2
6	KF000000030	SLO-BLO FUSE		*		1
7	HF0013020P0	FUSE 2A		*		1
8	KF000000050	SLO-BLO FUSE		*		1
9	40016464	POWER INPUT ASM.(CE)	FOR 1 ϕ 230V JE			1
10	M6102461DAA	AC INPUT CABLE ASM.(CE)		*		1
11	40017187	POWER COVER BASE		*		1
12	SL4040881SC	SCREW M4 L=8		*		2
13	CM300100001	LABEL		*		1
14	40006139	CABLE_D_ASSY		*		1
15	40017186	POWER COVER		*		1
16	40018368	POWER INPUT LA ASM.	FOR 1 ϕ 110~120V LA			1
17	40012009	PSC_UNIT_CABLE_B_ASSY		*		1
18	40017187	POWER COVER BASE		*		1
19	SL4040881SC	SCREW M4 L=8		*		2
20	CM300100001	LABEL		*		1
21	40017186	POWER COVER		*		1
22	40016493	PSC UNIT A ASSY	FOR 1 ϕ 110V/3 ϕ 220V JUS, 1 ϕ 110~120V LA			1
23	40016494	PSC UNIT B ASSY	FOR 1 ϕ 200~240V JS			1
24	40016495	PSC UNIT C ASSY	FOR 1 ϕ 230V JE			1
25	40018367	PSC UNIT D ASSY	FOR 1 ϕ 200~240V CN			1
26	SL4040881SC	SCREW M4 L=8		*		3
27	40017184	BOX HANGER		*		1
28	40016471	PEDAL SENSOR UNIT C ASSY		*		1
29	SM8040802TP	SCREW M4X8		*		2
30	40017195	PEDAL SENSOR BASE		*		1
31	40006112	PEDAL_LEVER		*		1
32	40017196	PEDAL SPRING		*		1
33	40006212	ADJUST_SCREW		*		2
34	40006202	ADJUST_NUT		*		2
35	40006211	SPRING_B		*		2
36	40006209	SPRING_SHAFT_B		*		1
37	40006208	SPRING_SHAFT_A		*		1
38	SM4030801SF	SCREW M3X0.5 L=8		*		1
39	40006206	SENSOR_INSTALLING_PLATE		*		1
40	40016526	PEDAL SENSOR ASSY		*		1
41	SV4030601SR	SCREW M3 L=6		*		2
42	EA9500B0100	CABLE BAND		*		1
43	40006204	PEDAL_LINK		*		1
44	40006205	VOLUME_LINK		*		1
45	40016524	RATING LABEL A	FOR 1 ϕ 110V/3 ϕ 220V JUS	*		1
46	40016525	RATING LABEL B	FOR 1 ϕ 200~240V JS	*		1

PSC UNIT COMPONENTS

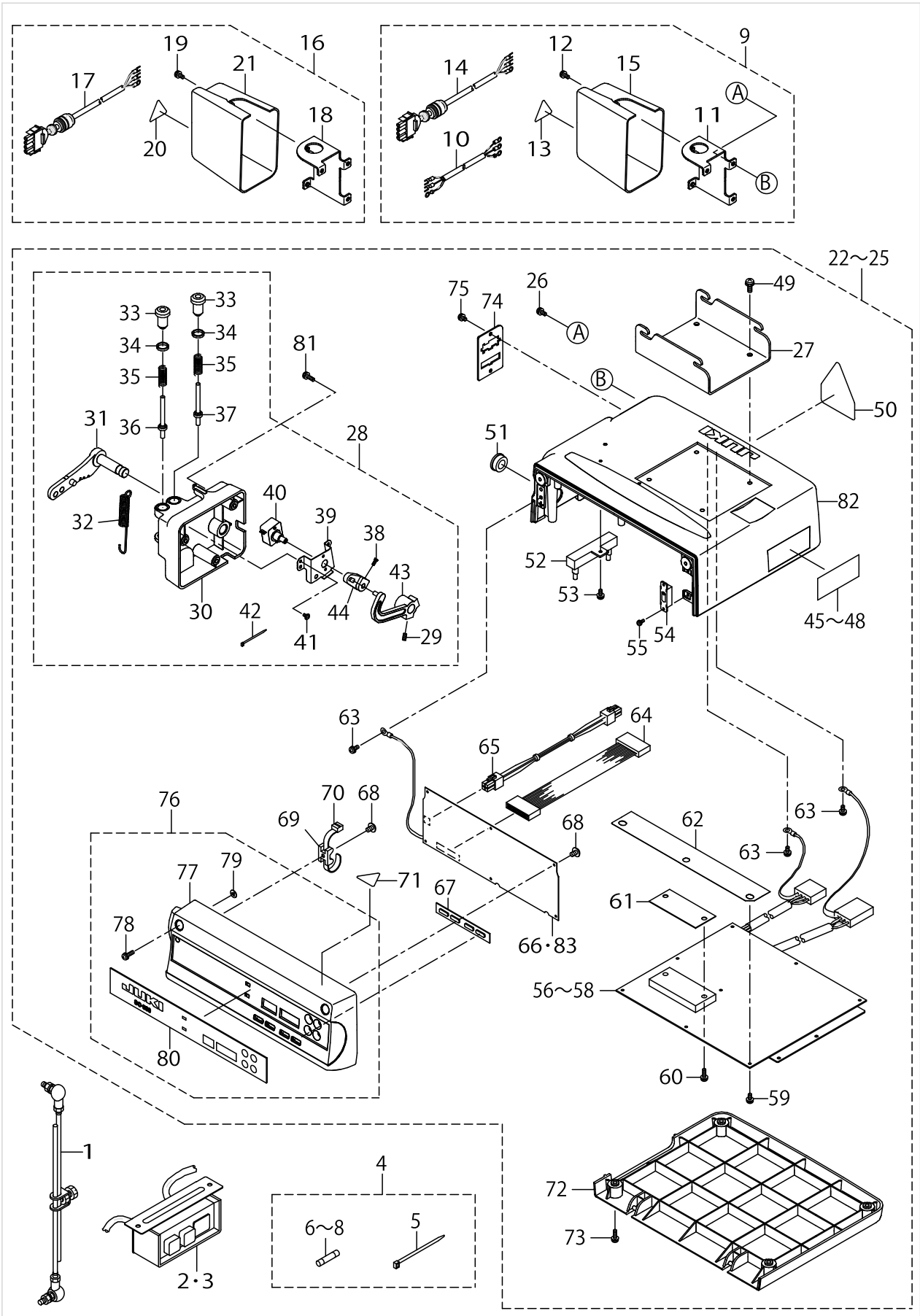

PSC UNIT COMPONENTS

No.	Parts No.	Parts name	Remarks	Level	Cons	Qty
47	40017775	RATING LABEL C	FOR 1 φ 230V JE	*		1
48	40018370	RATING LABEL D	FOR 1 φ 200~240V CN	*		1
49	SL4051091SC	SCREW M5X0.8 L=10		*		4
50	CM300400601	VOLTAGE CAUTION LABEL	FOR 1 φ 200~240V JS, 1 φ 23- 0V JE, 1 φ 200~240V CN	*		1
51	KX000000250	SNAP BUSHING		*		1
52	40058895	RESISTANCE_A_ASSY		*		1
53	SL4041081SC	SCREW M4 L=10		*		1
54	40016522	VOLTAGE SELECT CORD ASSY	FOR 1 φ 110V/3 φ 220V JUS, 1 φ 110~120V LA	*		1
55	SL4030881SC	SCREW M3X8	FOR 1 φ 110V/3 φ 220V JUS, 1 φ 110~120V LA	*		2
56	40016465	PWR PCB A ASSY	FOR 1 φ 110V/3 φ 220V JUS	*		1
57	40016466	PWR PCB B ASSY	FOR 1 φ 200~240V JS	*		1
58	40016467	PWR PCB C ASSY	FOR 1 φ 230V JE	*		1
59	SL4041081SC	SCREW M4 L=10		*		10
60	SL4041495SC	SCREW M4 L=14		*		2
61	40016529	COOL SHEET		*		1
62	40016528	SAFETY SHEET		*		1
63	SL4041081SC	SCREW M4 L=10		*		3
64	40016468	I/F CABLE ASSY		*		1
65	40016469	DC POWER SUPPLY CORD ASSY		*		1
66	40018442	CTL PCB ASSY (MO/MF)	FOR STANDARD	*		1
67	40016527	RUBBER SWITCH		*		1
68	SV4030802SN	TAPPING SCREW WITH FLANGE M3X8		*		7
69	KX000000260	SADDLE TYPE TIE MOUNT		*		1
70	HX00292000A	CONNECTING PART		*		1
71	CM300100001	LABEL		*		1
72	40017182	BOTTOM COVER		*		1
73	SL4041495SC	SCREW M4 L=14		*		4
74	40017185	CONNECTOR BRACKET		*		1
75	SL4040881SC	SCREW M4 L=8		*		2
76	40016520	FRONT COVER A ASSY		*		1
77	40017183	FRONT COVER		*		1
78	SL4041495SC	SCREW M4 L=14		*		2
79	M8002430000	STOPPER		*		2
80	40016521	OPERATION PANEL		*		1
81	SL4041495SC	SCREW M4 L=14		*		3
82	40017181	UPPER COVER		*		1
83	40085559	CTL PCB ASSY(MFD)	FOR MF-7700DU,MF-7800DU	*		1

MOTOR COMPONENTS

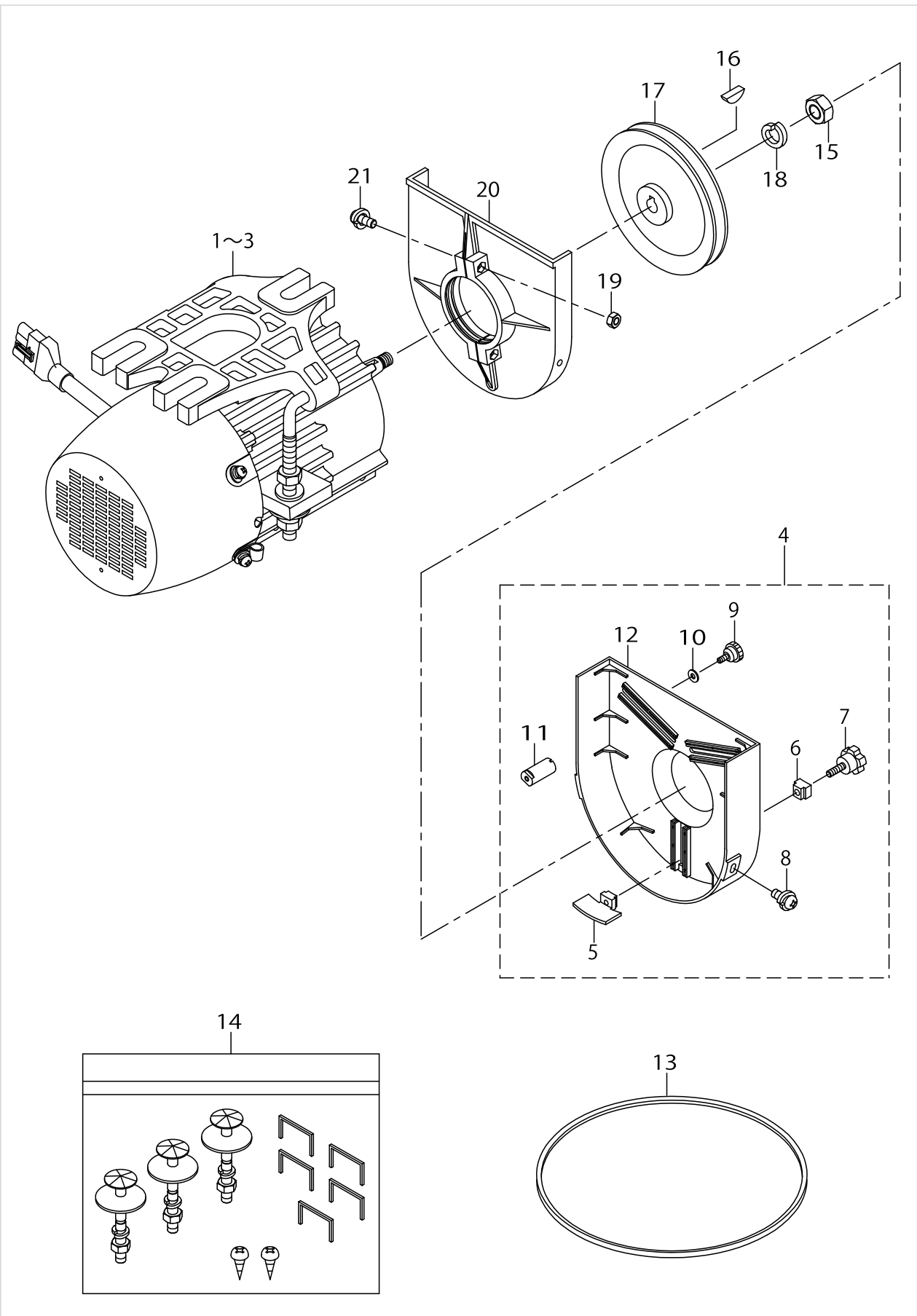

MOTOR COMPONENTS

No.	Parts No.	Parts name	Remarks	Level	Cons	Qty
1	40018511	M50 MOTOR UNIT A	FOR 1 ϕ 200~240V JS			1
2	40018512	M50 MOTOR UNIT B	FOR 1 ϕ 230V JE			1
3	40018513	M50 MOTOR UNIT C	FOR 1 ϕ 110V/3 ϕ 220V JUS, 1 ϕ 11- 0~120V LA, 1 ϕ 200~240V CN			1
4	40018509	M50 MOTOR BELT COVER ASSY				1
5	40018571	DROPPING PLATE		*		1
6	40018572	DROPPING PAD		*		1
7	40018573	SCREW		*		1
8	40018574	SCREW		*		2
9	40018570	SCREW		*		1
10	40018569	WASHER		*		1
11	40018568	SUPPORTING ROD		*		1
12	40018514	PULLEY COVER A		*		1
13	40018581	BELT M41				1
14	40018582	MOUNTING BOLT ASM				1
15	40018580	NUT				1
16	40018578	KEY				1
17	40018577	PULLEY 110				1
18	40018579	WASHER				1
19	40018576	NUT				2
20	40018567	PULLEY COVER B				1
21	40018575	SCREW				2

NUMERICAL INDEX OF PARTS

PART NO	PAGE	REF NO.	PART NO	PAGE	REF NO.	PART NO	PAGE	REF NO.
40006112	2	31	40018509	6	4	SM4030801SF	2	38
40006139	2	14	40018511	6	1~3	SM8040802TP	2	29
40006202	2	34	40018512	6	1~3	SV4030601SR	2	41
40006204	2	43	40018513	6	1~3	SV4030802SN	4	68
40006205	2	44	40018514	6	12			
40006206	2	39	40018567	6	20			
40006208	2	37	40018568	6	11			
40006209	2	36	40018569	6	10			
40006211	2	35	40018570	6	9			
40006212	2	33	40018571	6	5			
40012009	2	17	40018572	6	6			
40016464	2	9	40018573	6	7			
40016465	4	56~58	40018574	6	8			
40016466	4	56~58	40018575	6	21			
40016467	4	56~58	40018576	6	19			
40016468	4	64	40018577	6	17			
40016469	4	65	40018578	6	16			
40016471	2	28	40018579	6	18			
40016493	2	22~25	40018580	6	15			
40016494	2	22~25	40018581	6	13			
40016495	2	22~25	40018582	6	14			
40016520	4	76	40058895	4	52			
40016521	4	80	40085559	4	66·83			
40016522	4	54	CM300100001	2	71			
40016524	2	45~48	CM300100001	4	71			
40016525	2	45~48	CM300400601	4	50			
40016526	2	40	EA9500B0100	2	42			
40016527	4	67	EA9500B0200	2	5			
40016528	4	62	HF0013020P0	2	6~8			
40016529	4	61	HX00292000A	4	70			
40016531	2	4	KF000000030	2	6~8			
40017181	4	82	KF000000050	2	6~8			
40017182	4	72	KX000000250	4	51			
40017183	4	77	KX000000260	4	69			
40017184	2	27	M4501471AA0	2	1			
40017185	4	74	M6101471AA0	2	2·3			
40017186	2	21	M6101471CA0	2	2·3			
40017187	2	18	M6102461DAA	2	10			
40017195	2	30	M8002430000	4	79			
40017196	2	32	SL4030881SC	4	55			
40017775	4	45~48	SL4040881SC	2	75			
40018367	2	22~25	SL4040881SC	4	75			
40018368	2	16	SL4041081SC	4	63			
40018370	4	45~48	SL4041495SC	4	81			
40018442	4	66·83	SL4051091SC	4	49			