

MODEL : LU-1508/LU-1508H

List No : 1276-03

# PARTS LIST

Published:09/22/2017

## CONTENTS

---

FRAME & MISCELLANEOUS COVER COMPONENTS .....	1
UPPER SHAFT,LOWER SHAFT DRIVING & BALANCE COMPONENTS .....	3
NEEDLE BAR ROCKING COMPONENTS .....	7
PRESSURE ADJUSTING & UPPER FEED MECHANISM COMPONENTS.....	9
FEED MECHANISM COMPONENTS.....	13
HOOK SHAFT & LOWER SHAFT COMPONENTS .....	19
THREAD TENSION COMPONENTS .....	23
LOWER THREAD WINDER MECHANISM COMPONENTS .....	25
KNEE LIFTING COMPONENTS .....	27
BELT COVER & OIL RESERVOIR COMPONENTS.....	29
LUBRICATION COMPONENTS .....	31
ACCESSORIES PARTS COMPONENTS .....	33
THREAD STAND COMPONENTS.....	35
AUTOMATIC BACK COMPONENTS (FOR LU-1508 OPTIONAL PARTS) .....	37
OPTIONAL PARTS (ADDITIONAL SPRING FOR PRESSER BAR)COMPONENTS.....	41
SUSPENSION SQUARE (OPTION) COMPONENTS.....	43
OPTIONAL PARTS COMPONENTS (1).....	45
OPTIONAL PARTS COMPONENTS (2).....	47
LIST FOR INFORMATION OF CHANGE.....	49
HOW TO MAKE USE OF THIS PARTS LIST .....	50

FRAME & MISCELLANEOUS COVER COMPONENTS

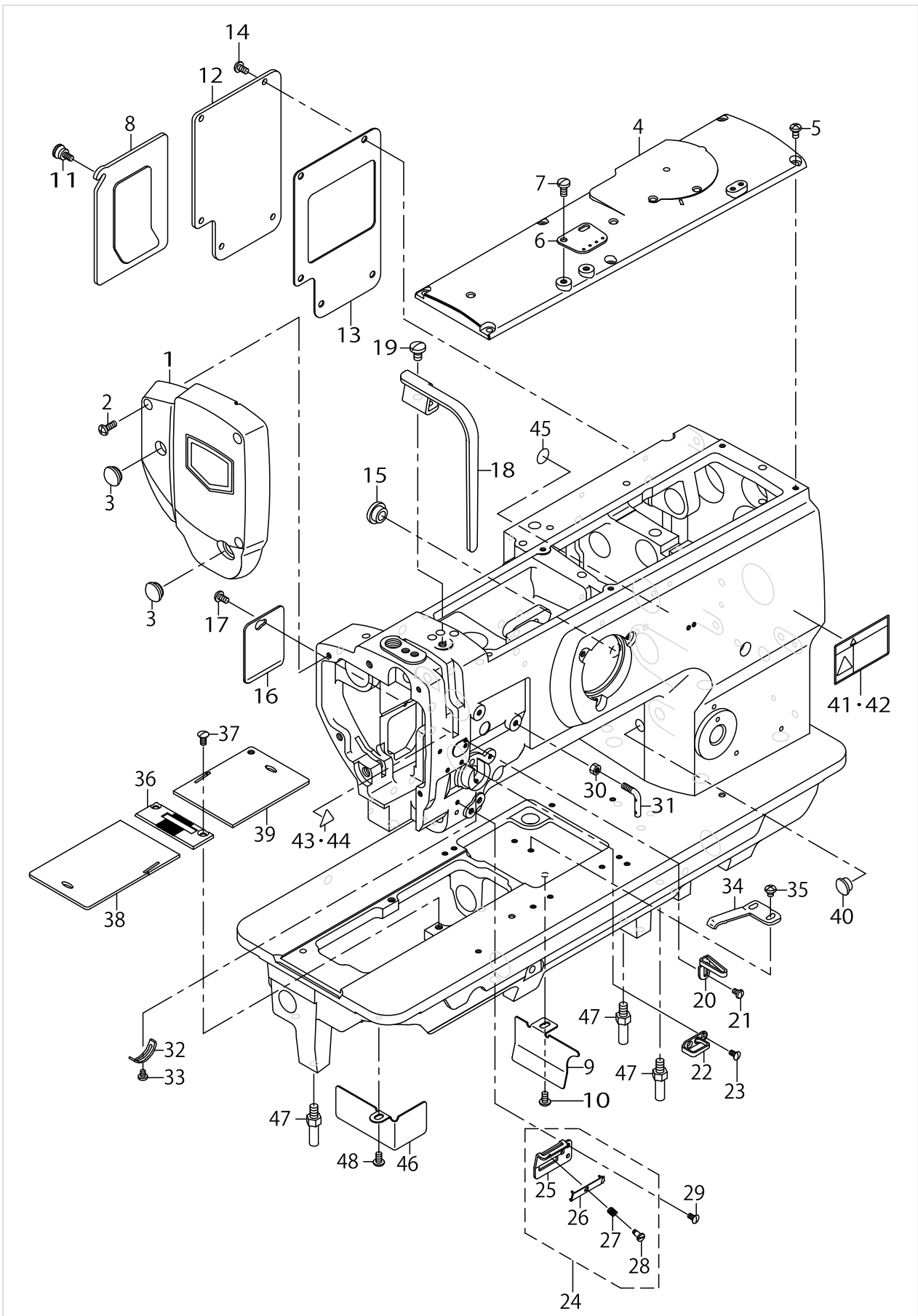

FRAME & MISCELLANEOUS COVER COMPONENTS

No.	Parts No.	Parts name	Remarks	Level	Cons	Qty
1	21331558	FACE PLATE ASM.				1
2	SS4111215SP	SCREW 11/64-40 L=12				3
3	TA1250406R0	RUBBER PLUG D=12.5 L=4				2
4	21331400	TOP COVER A				1
5	SS4110815SP	SCREW 11/64-40 L=8				6
6	21355904	ARM THREAD GUIDE				1
7	SS7621040SP	SCREW 3/16-32 L= 9.5				2
8	21331756	WINDOW PLATE A ASM.				1
9	22877609	DUST COVER				1
10	SS4110815SP	SCREW 11/64-40 L=8				2
11	21331202	SETSCREW				1
12	21331806	WINDOW PLATE B				1
13	21332002	WINDOW PLATE PACKING B				1
14	SS4110815SP	SCREW 11/64-40 L=8				5
15	TA1250504R0	RUBBER PLUG				1
16	21332309	SIDE COVER				1
17	SS4110815SP	SCREW 11/64-40 L=8				1
18	21331608	BALANCE COVER				1
19	SS7150910TP	SCREW 15/64-28 L=9				1
20	21355805	THREAD GUIDE	FOR LU-1508			1
21	SS5090610SP	SCREW 9/64-40 L=6				1
22	B1129051000	FRAME THREAD GUIDE, UPPER				1
23	SS2090710TP	SCREW 9/64-40 L=7.2				2
24	21408554	THREAD GUIDE ASM.				1
25	21408505	THREAD GUIDE PLATE		*		1
26	17912106	NEEDLE THREAD PRESSER PLATE		*		1
27	B1132521000	THREAD PRESSER PLATE SPRING		*		1
28	SD0380551SL	HINGE SCREW D= 3.80 H= 5.5		*		1
29	SS2090710TP	SCREW 9/64-40 L=7.2				1
30	NS6110420SP	NUT 11/64-40				1
31	B1114232000	FRAME THREAD EYELET, UPPER				1
32	B3138512000	TAKE-UP SPRING ADJUSTING PLATE				1
33	SS7090520TP	SCREW 9/64-40 L= 4.5				1
34	B1111563000	BED SLIDE SPRING				1
35	SS4110515SP	SCREW 11/64-40 L=5				2
36	B1109563000	THROAT PLATE				1
37	SS2110920TP	SCREW 11/64-40 L=8.5				2
38	21349600	SLIDING PLATE (LEFT)				1
39	21349709	SLIDING PLATE (RIGHT)				1
40	TA1050504R0	RUBBER PLUG				1
41	CM300200101	SAFETY LABEL, 1(SMALL).	FOR JAPAN			1
42	CM3002001A1	SAFETY LABEL.,3 (SMALL).	EXCEPT JAPAN			1
43	CM3002000B1	LABEL(16)	FOR JAPAN			1
44	CM300200001	ATTENTION SEAL	EXCEPT JAPAN			1
45	10004109	GROUND MARK				1
46	21332200	OIL SHIELD (LEFT)				1
47	22602601	BED SCREW STUD				3

UPPER SHAFT, LOWER SHAFT DRIVING & BALANCE COMPONENTS

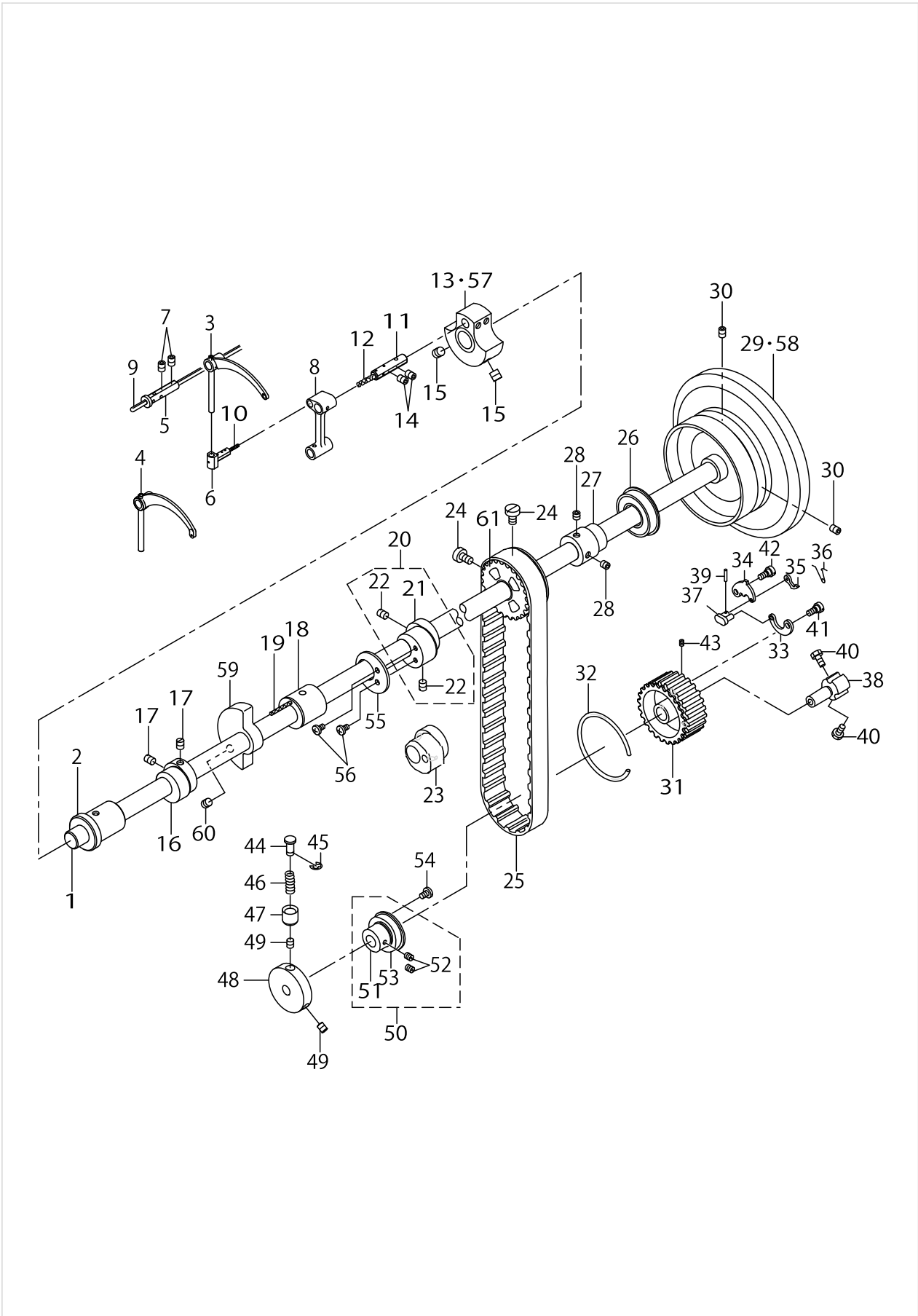

UPPER SHAFT,LOWER SHAFT DRIVING & BALANCE COMPONENTS

No.	Parts No.	Parts name	Remarks	Level	Cons	Qty
1	21332705	UPPER SHAFT				1
2	21333000	UPPER SHAFT FRONT METAL				1
3	B1905563000	THREAD TAKE-UP LEVER ASM.	FOR LU-1508			1
4	B1905241H00	THREAD TAKE-UP LEVER	FOR LU-1508H			1
5	B1906051000	TAKE-UP LEVER PIN				1
6	B1907051000	TAKE-UP LEVER THRUST PIN				1
7	SS8150822TP	SCREW 15/64-28 L=8				2
8	21339106	NEEDLE BAR CRANK ROD				1
9	CQ303000000	OIL WICK				0.45
10	CQ202000000	OIL WICK				0.03
11	B1210051000	NEEDLE BAR CRANK PIN				1
12	CQ505000000	OIL WICK				0.03
13	21332507	COUNTER WEIGHT (A) (36MM)	FOR LU-1508			1
14	SS8150822TP	SCREW 15/64-28 L=8				2
15	SM8080812TP	SCREW M8X8				2
16	21339502	UPPER FEED CAM (3.5)				1
17	SS8660810TP	SCREW 1/4-40 L=8				2
18	21333109	UPPER SHAFT INNER METAL				1
19	CQ202000000	OIL WICK				0.15
20	21336557	ECCENTRIC CAM A ASM.				1
21	21336508	ECCENTRIC CAM A	FOR LU-1508	*		1
22	SS8660810TP	SCREW 1/4-40 L=8		*		2
23	21352505	TRIANGULAR CAM	FOR LU-1508H			1
24	SS6661110SP	SCREW 1/4-40 L=11				2
25	22604300	TIMING BELT				1
26	B1203512000	BUSHING, REAR				1
27	10704906	UPPER SHAFT BEARING HOOK				1
28	SM8060602TP	SCREW M6X6				2
29	21334008	FLYWHEEL	FOR LU-1508			1
30	SS8150822TP	SCREW 15/64-28 L=8				2
31	21333505	LOWER SPROCKET				1
32	B1214019000	SPROCKET RING				1
33	B1305055000A	SAFETY CLUTCH SPRING				1
34	B1307055000	SAFETY CLUTCH HOOK				1
35	B1308055000	SAFETY CLUTCH COUNTER-HOOK				1
36	B1309055000	COUNTER-HOOK SPRING				1
37	B1310055000	SAFETY CLUTCH SMALL LINK				1
38	10503605	SAFETY BASE				1
39	B1314055000	SAFETY CLUTCH SMALL LINK PIN				1
40	SS6661110SP	SCREW 1/4-40 L=11				2
41	SD0640322TP	HINGE SCREW D= 6.35 H= 3.2				1
42	SD0640322TP	HINGE SCREW D= 6.35 H= 3.2				1
43	SS8090540SP	SCREW 9/64-40 L=5				1
44	B1312563000A	SAFETY CLUTCH PUSH BUTTON				1
45	RE0500000K0	E-RING				1
46	B1639051000	SPRING				1
47	B1313055000	SAFETY CLUTCH KNOB SLEEVE				1

UPPER SHAFT, LOWER SHAFT DRIVING & BALANCE COMPONENTS

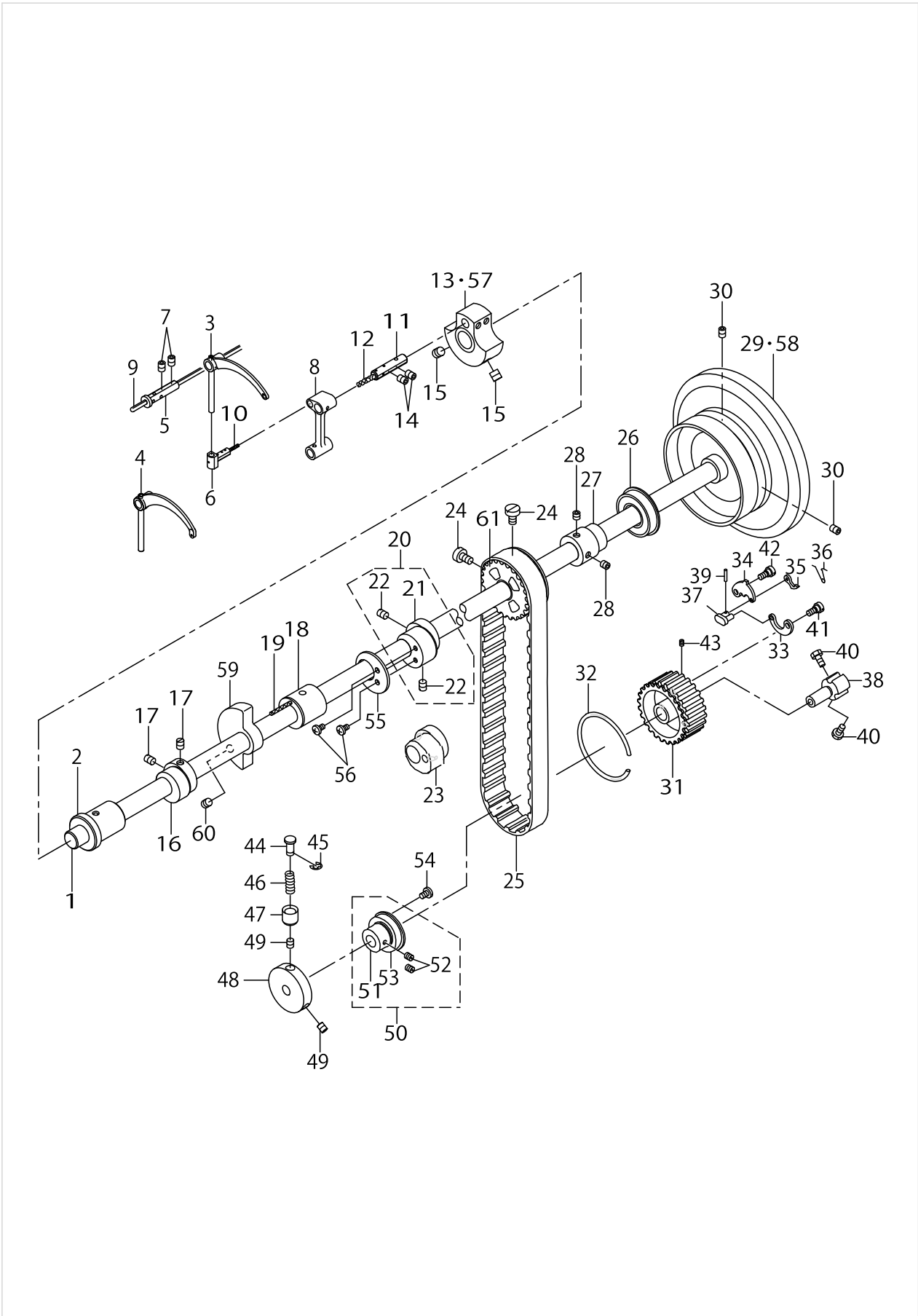

UPPER SHAFT,LOWER SHAFT DRIVING & BALANCE COMPONENTS

No.	Parts No.	Parts name	Remarks	Level	Cons	Qty
48	21333703	SAFETY CLUTCH DISC				1
49	SS8150710TP	SCREW 15/64-28 L=7				2
50	22611651	THRUST COLLAR ASM., B				1
51	22611602	THRUST COLLAR, B		*		1
52	SS8661030SP	SCREW 1/4-40 L=10		*		2
53	SB120000200	BEARING 20X42		*		1
54	SS7120760SP	SCREW 3/16-28 L= 7.0				2
55	21353008	HORIZONTAL FEED CAM COVER				1
56	SS7110710SP	SCREW 11/64-40 L=7				2
57	21332606	COUNTER WEIGHT (B) (38MM)	FOR LU-1508H			1
58	21332903	FLYWHEEL	FOR LU-1508H			1
59	21333406	BALANCER	FOR LU-1508			1
60	SS8151550SP	SCREW 15/64-28 L=15	FOR LU-1508			2
61	22604904	UPPER SPROCKET				1



NEEDLE BAR ROCKING COMPONENTS

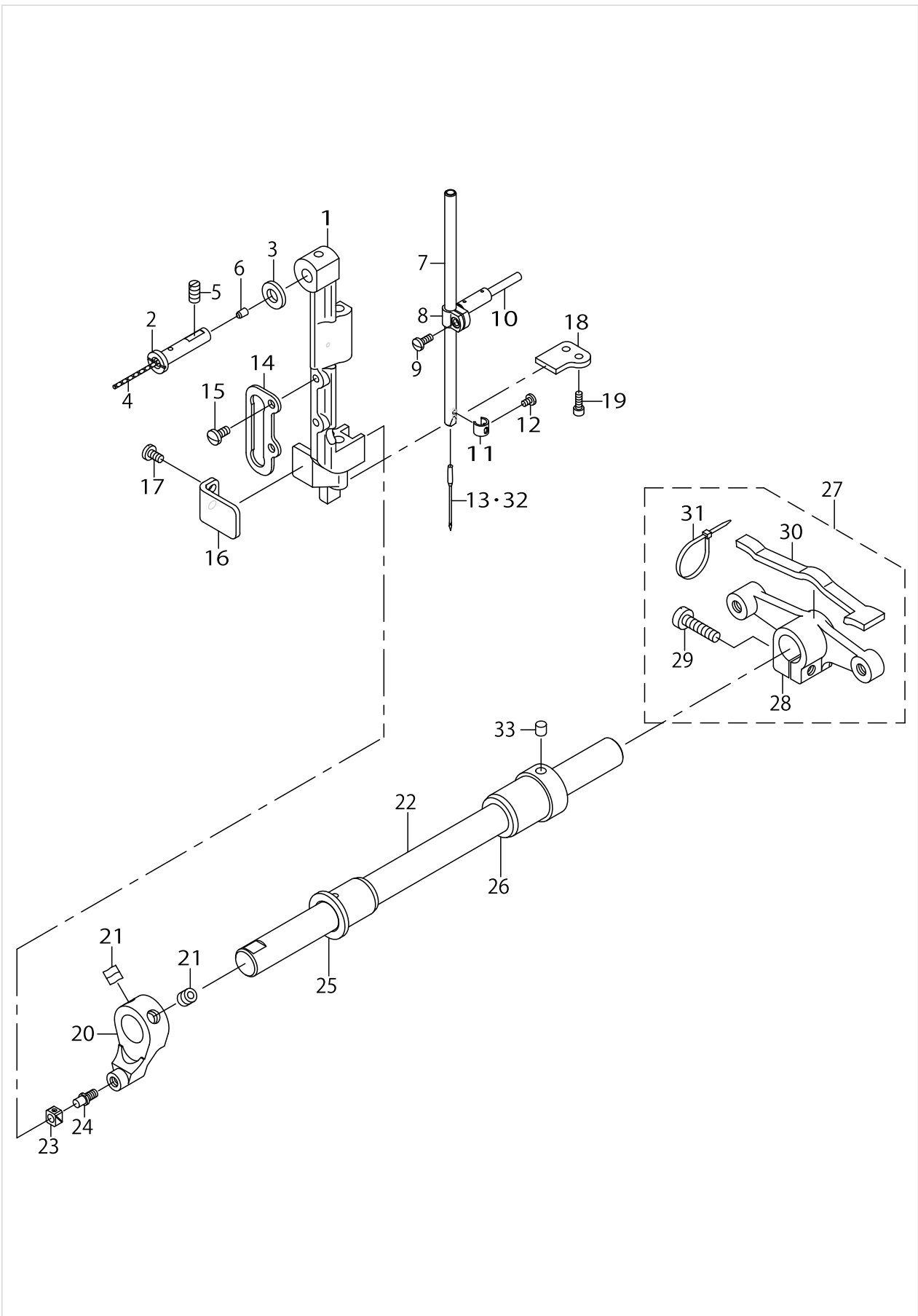

NEEDLE BAR ROCKING COMPONENTS

No.	Parts No.	Parts name	Remarks	Level	Cons	Qty
1	B1420563000	NEEDLE BAR FRAME				1
2	21339403	HINGE STUD				1
3	B185351200CA	HOOK SHAFT WASHER, C				1
4	CQ202000000	OIL WICK				0.05
5	SS8151150TP	SCREW 15/64-28 L=10.5				1
6	TA0370601M0	PLUG D=3.9X4 L=6				1
7	B1401053000	NEEDLE BAR				1
8	B1411053000	NEEDLE BAR CONNECTION				1
9	SS7090910SP	SCREW 9/64-40 L= 8.5				1
10	B1412051000	FELT				1
11	10308609	THREAD GUARD				1
12	SS7080510TP	SCREW 1/8-44 L=4.5				1
13	MC372001600	NEEDLE SY3355 160				1
14	B1467563000	UPPER FEED BAR GUIDE				1
15	SS7110910TP	SCREW 11/64-40 L= 8.5				2
16	21338702	ROCKING BASE GUIDE				1
17	SS7110830SP	SCREW 11/64-40 L= 7.5				2
18	21338603	ROCKING BASE GUIDE (B)				1
19	SS6091022TP	SCREW				2
20	21338801	ROCKING FRONT ARM				1
21	SM8080802TP	SCREW				2
22	21338900	ROCKING SHAFT				1
23	B1414232000	SQUARE BLOCK				1
24	B1410771000	STUD				1
25	21339304	ROCKING SHAFT FRONT METAL				1
26	21339205	ROCKING SHAFT REAR METAL				1
27	21339056	ROCKING REAR ARM ASM.				1
28	21339007	ROCKING REAR ARM		*		1
29	SS6152440SP	SCREW 15/64-28 L=23.5		*		1
30	21347406	ROCKING REAR ARM FELT		*		1
31	EA9500B0100	CABLE BAND		*		2
32	MC0190R1600	NEEDLE 190R #160	FOR LU-1508H			1
33	22814909	FELT				1

PRESSURE ADJUSTING & UPPER FEED MECHANISM COMPONENTS

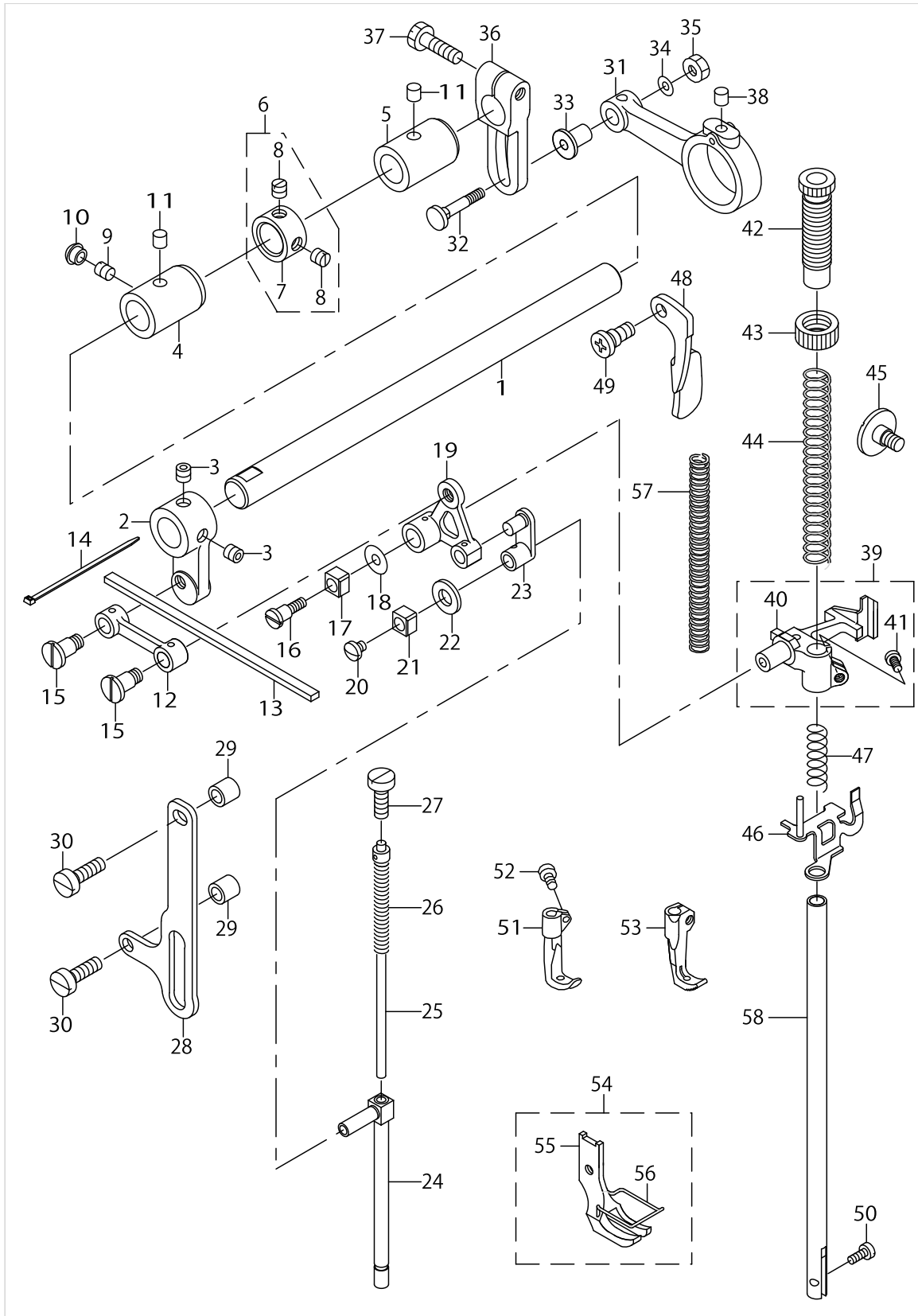

PRESSURE ADJUSTING & UPPER FEED MECHANISM COMPONENTS

No.	Parts No.	Parts name	Remarks	Level	Cons	Qty
1	21340401	UPPER FEED SHAFT				1
2	21340500	UPPER FEED FRONT ARM				1
3	SS8660612TP	SCREW 1/4-40 L=6				2
4	21341904	FRONT METAL				1
5	21378302	FEED ROCK SHAFT METAL				1
6	22904155	MAIN SHAFT THRUST COLLAR ASM.				1
7	22904106	MAIN SHAFT THRUST COLLAR		*		1
8	SS8660610TP	SCREW 1/4-40 L=6		*		2
9	SS8150710SP	SCREW 15/64-28 L=7				1
10	TA0750404R0	PLUG D=7.5 L=3.5				1
11	22814909	FELT				2
12	21339908	UPPER FEED LINK				1
13	21347109	FELT				1
14	EA9500B0000	CLIP CV-70S				2
15	B3016141H00	HINGE SCREW, B				2
16	SD0640701SP	HINGE SCREW D=6.35 H=7				1
17	B1414555000	SLIDE BLOCK				1
18	WP0501046SC	WASHER 5 X 13 X 1				1
19	21340807	TRIANGULAR LEVER				1
20	SS7110510SP	SCREW 11/64-40 L=5				1
21	B1414555000	SLIDE BLOCK				1
22	10509701	FELT				1
23	B1465053000	WALKING BAR DRIVING LINK				1
24	B1466563000	WALKING BAR				1
25	B14670530A0	WALKING BAR ASM.				1
26	B1468053000	WALKING BAR SPRING				1
27	SS6151780SP	SCREW 15/64-28 L=17.0				1
28	21341300	UPPER FEED GUIDE PLATE				1
29	13514310	ROLLER				2
30	SS6151920SP	SCREW 15/64-28 L=19.0				2
31	21340104	UPPER FEED ROD				1
32	D1456055B00	HINGE SCREW				1
33	D1455055B00	CONNECTING STUD				1
34	WP0482086SD	WASHER 4.8X11.5X2				1
35	NS6110530SP	NUT 11/64-40				1
36	21340203	UPPER FEED REAR ARM				1
37	SM9062250SC	SCREW M6 L=22				1
38	22814909	FELT				1
39	21341052	PRESSER BAR HOLDER ASM.				1
40	21341003	PRESSER BAR HOLDER		*		1
41	SS7110910TP	SCREW 11/64-40 L= 8.5		*		1
42	21340906	PRESSER ADJUSTING SCREW				1
43	B1511555000	NUT				1
44	B1502246000	PRESSER SPRING				1
45	SD0800481SP	HINGE SCREW D= 8 H= 4.9				1
46	21341151	THREAD RELEASE HOLDING PLATE				1
47	B1462053000	THREAD RELEASE SPRING				1

PRESSURE ADJUSTING & UPPER FEED MECHANISM COMPONENTS

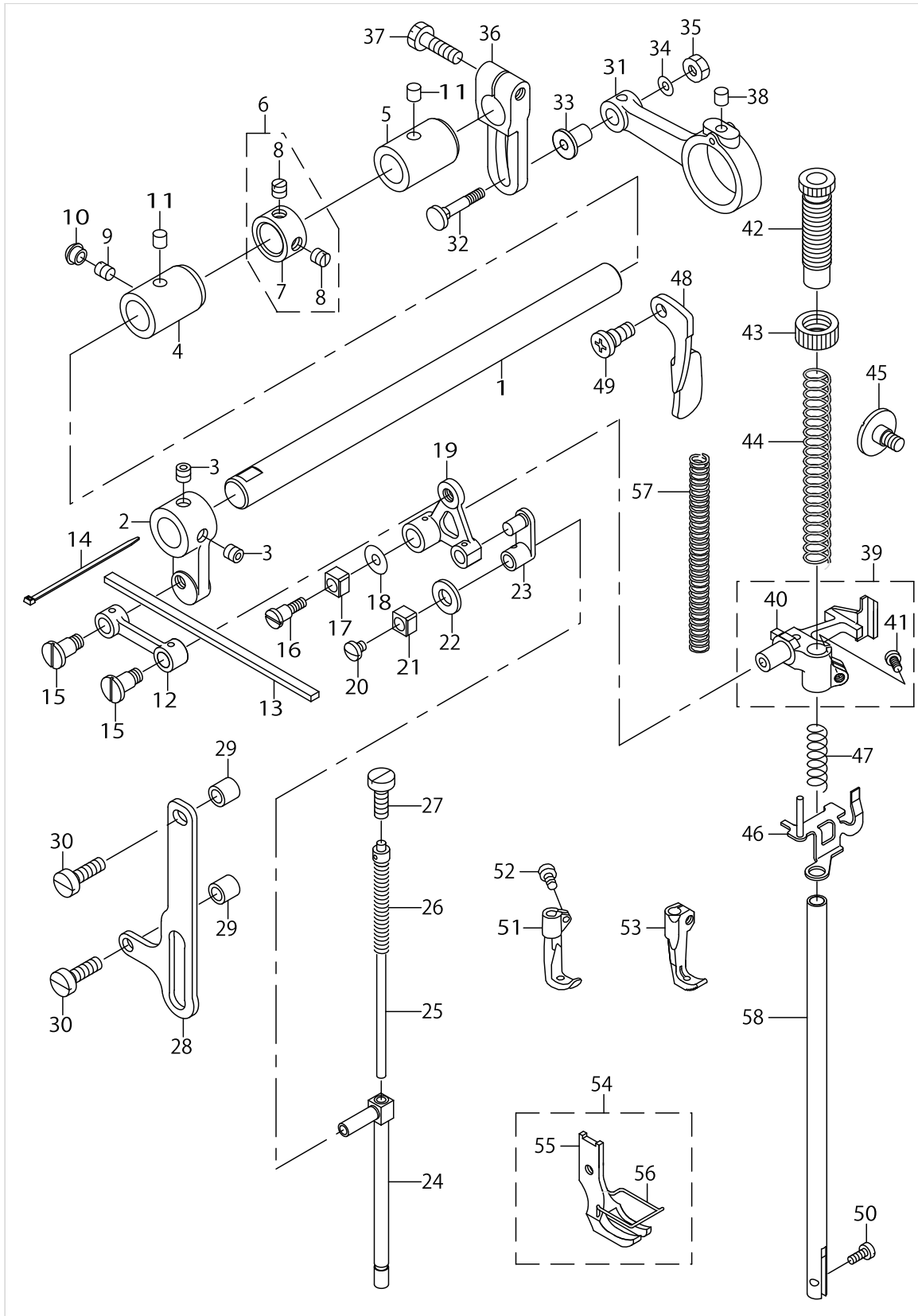

PRESSURE ADJUSTING & UPPER FEED MECHANISM COMPONENTS

No.	Parts No.	Parts name	Remarks	Level	Cons	Qty
48	21343504	PRESSER LIFTER LEVER				1
49	11006509	LINK SHAFT				1
50	SS6090910TP	SCREW 9/64-40 L=9				1
51	B1470241H00	WALKING FOOT				1
52	B1471241H00	SCREW				1
53	21350004	UPPER FEED FOOT	OPTIONAL PARTS (FOR THICK THREAD)			1
54	B1525241HA0	PRESSER FOOT ASM.				1
55	B1525241H00	PRESSER FOOT		*		1
56	10337905	FINGER GUARD		*		1
57	B1510141H00	PRESSER SPRING	OPTIONAL PARTS			1
58	B1501241H00	PRESSER BAR				1

FEED MECHANISM COMPONENTS

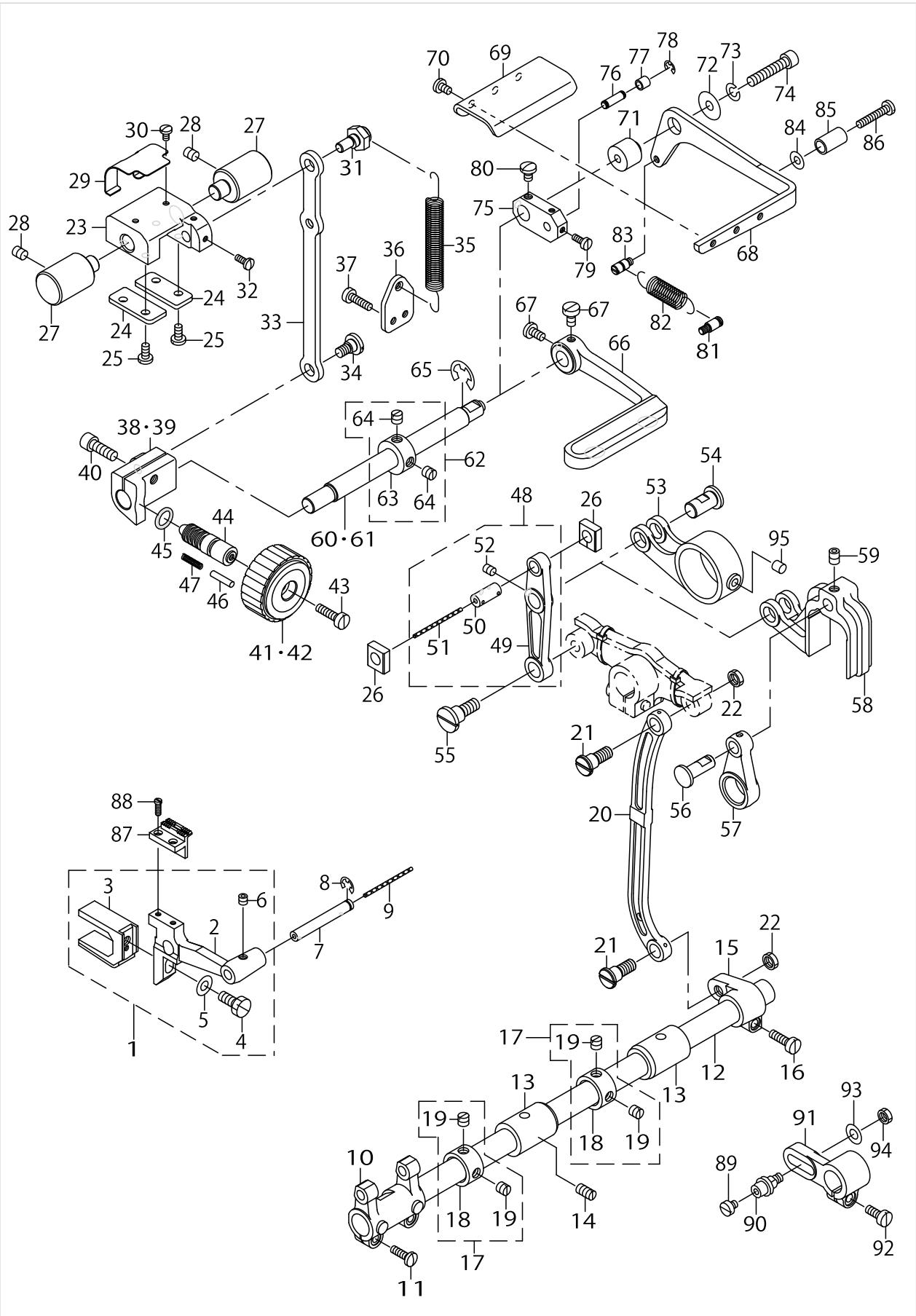

FEED MECHANISM COMPONENTS

No.	Parts No.	Parts name	Remarks	Level	Cons	Qty
1	21336052	FEED BASE ASM. (A)				1
2	21336003	FEED BASE		*		1
3	B1604051000	FEED BAR SLIDE FORK		*		1
4	SS9151440CP	SCREW 15/64-28 L=14		*		1
5	WP0621016SD	WASHER 6.2X13X1		*		1
6	SM8050502TP	SCREW M5 L=5		*		1
7	B1604012000A	FEED BAR SHAFT				1
8	RE0500711KP	SNAP RING 5				1
9	CQ202000000	OIL WICK				0.14
10	21364104	FEED ROCKER				1
11	SS7111410SP	SCREW 11/64-40 L=14				2
12	22609408	FEED ROCK SHAFT				1
13	21378302	FEED ROCK SHAFT METAL				2
14	SS8151150TP	SCREW 15/64-28 L=10.5				1
15	22609309	FEED ROCKER SHAFT CRANK				1
16	SS6121610TP	SCREW 3/16-28 L=15.5				1
17	22904155	MAIN SHAFT THRUST COLLAR ASM.				2
18	22904106	MAIN SHAFT THRUST COLLAR		*		1
19	SS8660610TP	SCREW 1/4-40 L=6		*		2
20	10205201	NEEDLE BAR FRAME ROD				1
21	SD0900701TP	HINGE SCREW D= 9 H= 7				2
22	NS6680320SP	NUT 9/32-28				2
23	21337506	FEED ADJUSTING BASE				1
24	21337704	FEED ADJUSTING BASE COVER				2
25	SS7110910TP	SCREW 11/64-40 L= 8.5				4
26	21337407	SQUARE BLOCK				2
27	21337803	FEED ADJUSTING BASE SUPPORT				2
28	SS8150822TP	SCREW 15/64-28 L=8				2
29	21338306	FELT SUPPORT				1
30	SS7090610SP	SCREW 9/64-40 L=6				2
31	21337902	ECCENTRIC PIN				1
32	SS7090910TP	SCREW 9/64-40 L= 8.5				2
33	21337308	FEED ADJUSTING ROD				1
34	SD0800402TP	HINGE SCREW D= 8 H= 4				1
35	21337605	SPRING				1
36	21338009	SPRING HOOK				1
37	SS6111610SP	SCREW 11/64-40 L=16				2
38	21337209	FEED ADJUSTING A	FOR LU-1508			1
39	21338108	FEED ADJUSTING B	FOR LU-1508H			1
40	SM6061802TP	SCREW M6 L=18				1
41	21336805	FEED DIAL A	FOR LU-1508			1
42	21336904	FEED DIAL B	FOR LU-1508H			1
43	SS6121860SP	SCREW 3/16-28 L=18				1
44	11009909	FEED REGULATOR SCREW				1
45	RO092270200	RUBBER RING				1
46	11052701	PIN				1
47	22912109	FEED REGULATOR PIN SPRING				1



FEED MECHANISM COMPONENTS

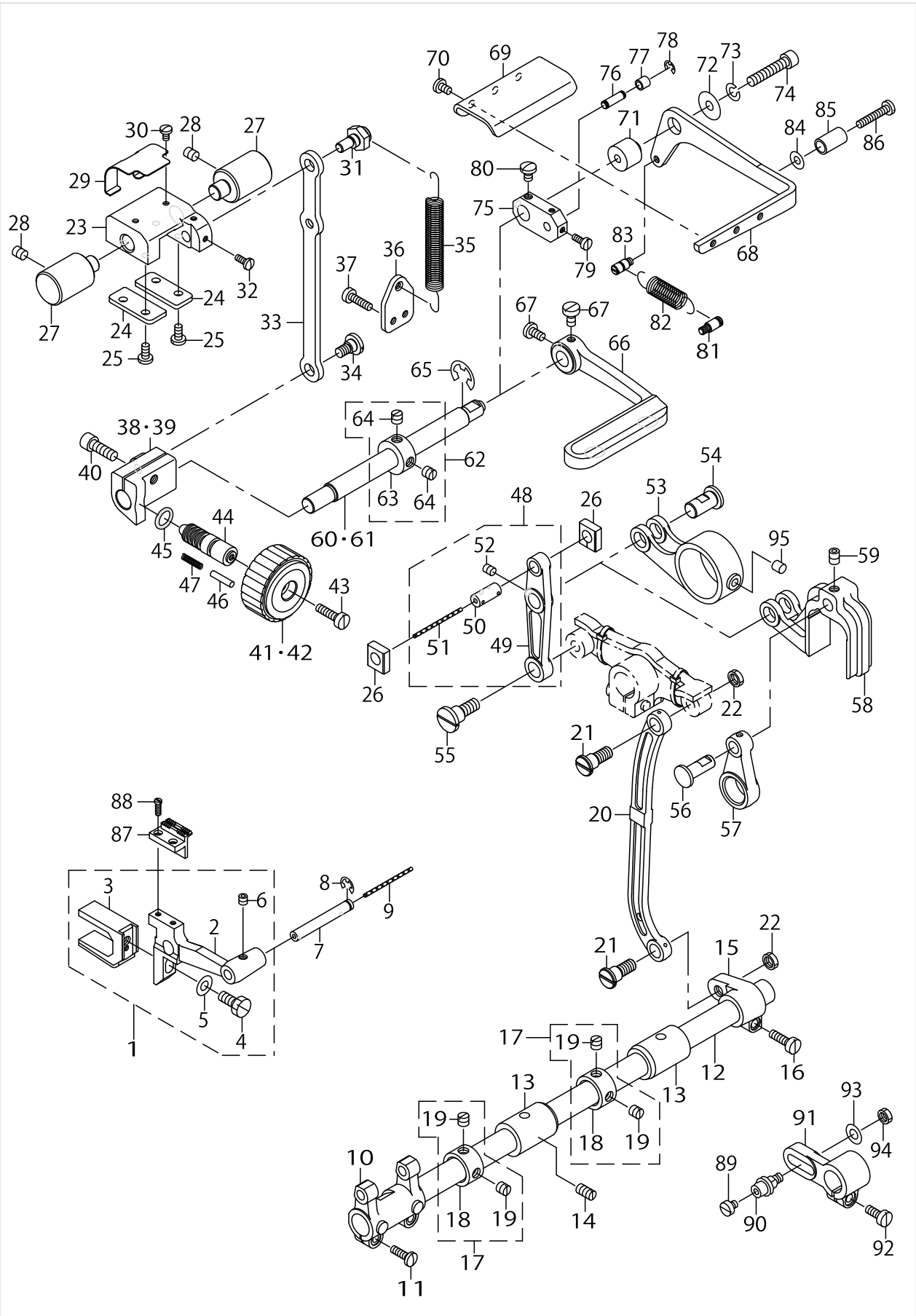

FEED MECHANISM COMPONENTS

No.	Parts No.	Parts name	Remarks	Level	Cons	Qty
48	21336656	FEED LINK ASM.				1
49	21336607	FEED LINK		*		1
50	B1418761000	CONNECTING FORKED LINK PIN		*		1
51	CQ202000000	OIL WICK		*		0.04
52	SM8050612TP	SCREW M5X6		*		1
53	21336706	FEED ROD A	FOR LU-1508			1
54	21338207	FEED LINK PIN				1
55	SD1000801SH	HINGE SCREW D=10 H=8				1
56	21352703	FEED TRIANGULAR CAM PIN	FOR LU-1508H			1
57	10083202	REAR CRANK	FOR LU-1508H			1
58	21352604	FEED TRIANGULAR CAM ROD	FOR LU-1508H			1
59	SS8150822TP	SCREW 15/64-28 L=8	FOR LU-1508H			1
60	21336300	BACKWARD FEED LEVER SHAFT	FOR LU-1508			1
61	21336409	BACKWARD FEED LEVER SHAFT B	FOR LU-1508H			1
62	CS1201010SH	THRUST COLLAR ASM. D=12 W=10				1
63	CS1201011SH	THRUST COLLAR D=12 W=10		*		1
64	SS8660610TP	SCREW 1/4-40 L=6		*		2
65	RE0900000K0	E-RING 9				1
66	22610505	REVERSE FEED CONTROL LEVER	FOR LU-1508			1
67	SS6120930TP	SCREW 3/16-28 L=9	FOR LU-1508			2
68	21337001	BACKWARD FEED LEVER B	FOR LU-1508H			1
69	21337100	BACKWARD FEED PRESSER PLATE	FOR LU-1508H			1
70	SS7110710SP	SCREW 11/64-40 L=7	FOR LU-1508H			3
71	21352901	BACKWARD FEED LINK FULCRUM	FOR LU-1508H			1
72	WP0612056SD	WASHER 6.1X18.5X2	FOR LU-1508H			1
73	WS0610002KP	SPRING WASHER	FOR LU-1508H			1
74	SS6153012TP	SCREW 15/64-28	FOR LU-1508H			1
75	21352802	CHANGE BASE	FOR LU-1508H			1
76	D2461481C00	CONNECTING PIN	FOR LU-1508H			1
77	B2507372000	CAM ROLL	FOR LU-1508H			1
78	RE0400000K0	E-RING 4	FOR LU-1508H			1
79	SS6090910SP	SCREW 9/64-40 L=9	FOR LU-1508H			2
80	SS7120710SP	SCREW 3/16-28 L=7	FOR LU-1508H			1
81	10120004	SPRING SUSPENSION	FOR LU-1508H			1
82	13789201	TENSION SPRING	FOR LU-1508H			1
83	11272614	FEED SPRING HOOK	FOR LU-1508H			1
84	WP0502616SD	WASHER	FOR LU-1508H			1
85	11100500	REVERSE FEED LEVER STOPPER	FOR LU-1508H			1
86	SS7112420SP	SCREW 11/64-40 L=24	FOR LU-1508H			1
87	21349303	FEED DOG (2.5X7.2)				1
88	B1611055000	SCREW				2
89	SS6110520TP	SCREW 11/64-40 L=4.5	OPTIONAL PARTS			1
90	10122000	CONNECTING PIN	OPTIONAL PARTS			1
91	B3025141H00A	CONNECTING ARM	OPTIONAL PARTS			1
92	SS6121210TP	SCREW 3/16-28 L=12	OPTIONAL PARTS			1
93	WP0650876SD	WASHER 6.5X13X0.8	OPTIONAL PARTS			1
94	NS6150310SP	NUT 15/64-28	OPTIONAL PARTS			1

FEED MECHANISM COMPONENTS

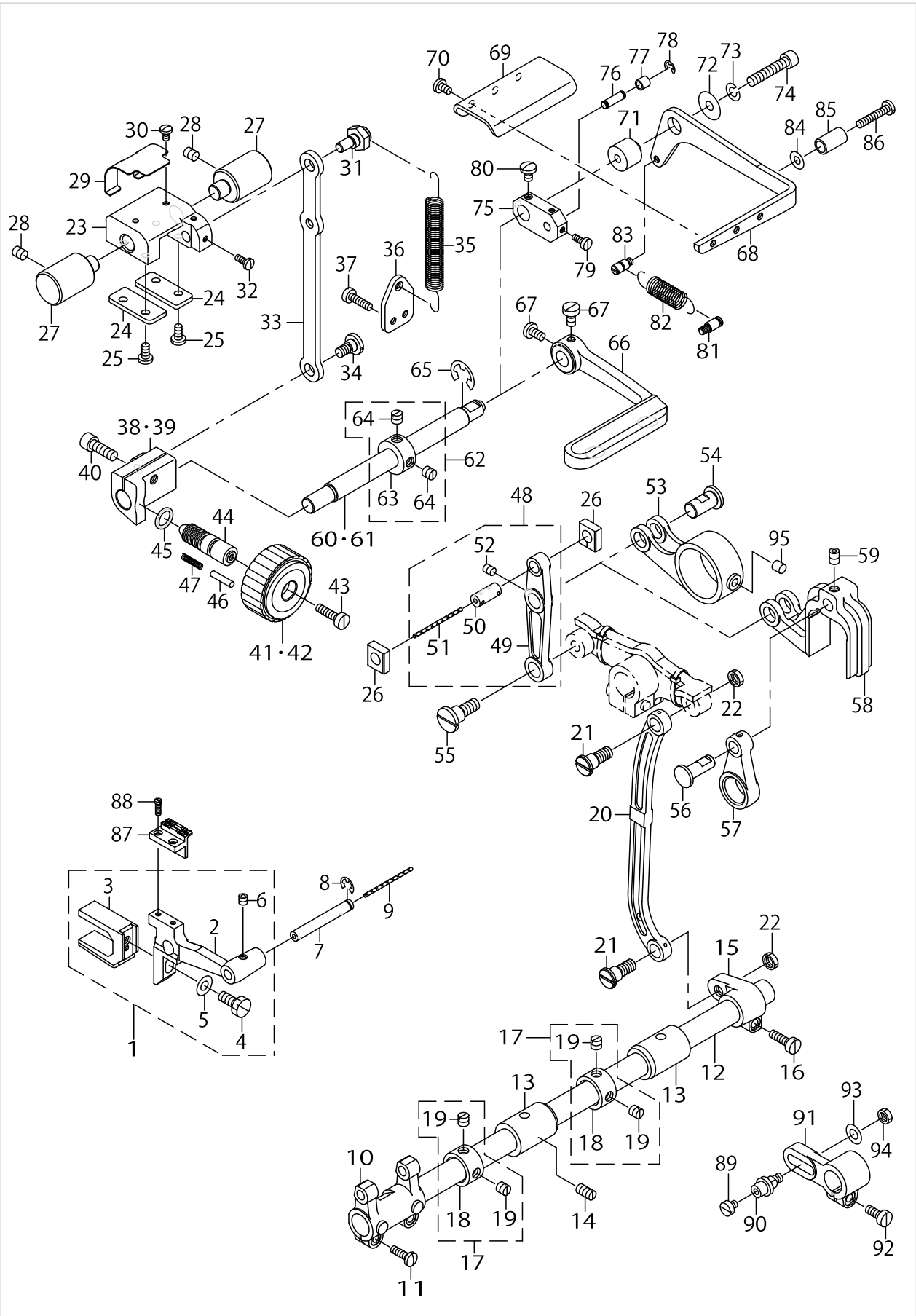

## FEED MECHANISM COMPONENTS

No.	Parts No.	Parts name	Remarks	Level	Cons	Qty
95	22814909	FELT				1

# HOOK SHAFT & LOWER SHAFT COMPONENTS

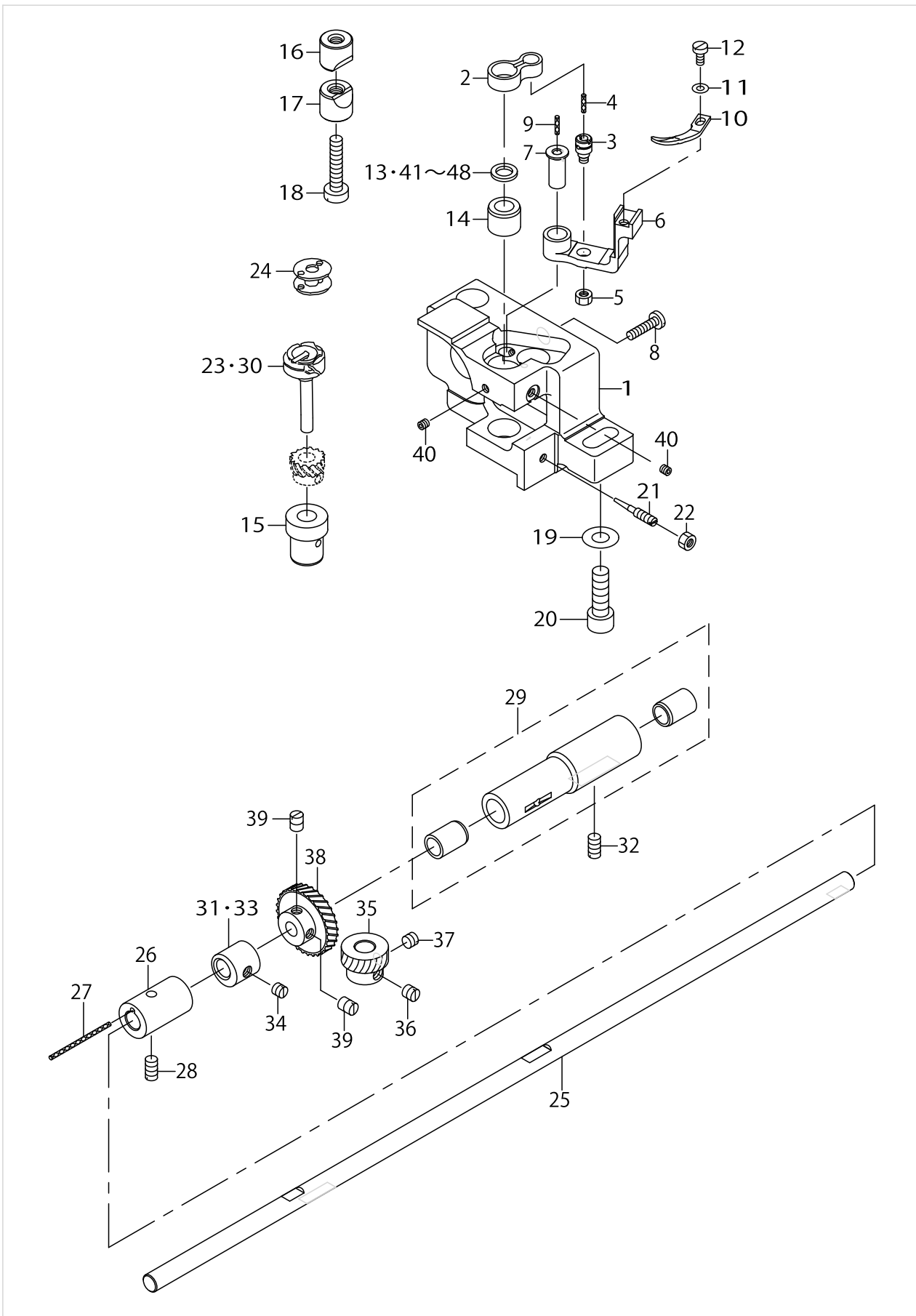

## HOOK SHAFT & LOWER SHAFT COMPONENTS

No.	Parts No.	Parts name	Remarks	Level	Cons	Qty
1	21335005	HOOK SHAFT BASE (RIGHT)				1
2	B1820563000	BOBBIN CASE OPENING LEVER LINK				1
3	B1821051000	CRANK SCREW STUD				1
4	CQ202000000	OIL WICK				0.01
5	NS6110420SP	NUT 11/64-40				1
6	B1822563000	BOBBIN CASE OPENING LEVER CRAN				1
7	B1823051000	OPENING LEVER CRANK PIN				1
8	SS7111810SP	SCREW 11/64-40 L=18				1
9	CQ202000000	OIL WICK				0.01
10	B1824563000	BOBBIN CASE OPENING LEVER				1
11	WP0371016SD	WASHER 3.7X8X1				1
12	SS6090810SP	SCREW 9/64-40 L= 7.5				1
13	10111102	THRUST WASHER 1.3	SELECTIVE PARTS			1
14	21378500	HOOK SHAFT UPPER METAL				1
15	21334701	HOOK SHAFT LOWER METAL				1
16	10109908	SADDLE INSTALLING BLOCK, UPPER				1
17	10112407	SADDLE INSTALLING BLOCK, LOWER				1
18	SS6153040SP	SCREW 15/64-28 L=30				1
19	WP0850002SP	WASHER 8.5X18X1.6				1
20	SM6082502TP	SCREW M8 L=25				1
21	B1843563000	OIL ADJUSTING SCREW				1
22	NS6110420SP	NUT 11/64-40				1
23	B18305630A0	VERTICAL-AXIS SEWING HOOK ASM.				1
24	B9117563000	BOBBIN				1
25	21333604	LOWER SHAFT				1
26	B1802563000A	HOOK DRIVING SHAFT FRONT METAL				1
27	CQ202000000	OIL WICK				0.04
28	SS8151150TP	SCREW 15/64-28 L=10.5				1
29	B18035150A0	BUSHING ASM., INTERMEDIATE				1
30	B1830563BA0	HOOK ASM., FOR EXTREME THICK T	FOR LU-1508H(THICK THREAD)			1
31	B184005100A	VERTICAL FEED CAM	OPTIONAL PARTS			1
32	SS8151150TP	SCREW 15/64-28 L=10.5				1
33	B1840051000	FEED DRIVING ECCENTRIC				1
34	SS8150510TP	SCREW 15/64-28 L= 4.7				1
35	B1817051000	HOOK DRIVING SHAFT GEAR, SMALL				1
36	SS8660670SP	SCREW 1/4-40 L= 6.1				1
37	SS8660530TP	SCREW 1/4-40 L= 4.5				1
38	B1816051000	HOOK DRIVING SHAFT GEAR, LARGE				1
39	SS8660810TP	SCREW 1/4-40 L=8				2
40	SS8110422TP	SCREW 11/64-40 L=4				2
41	10109700	THRUST WASHER, A	SELECTIVE PARTS			1
42	10109809	THRUST WASHER, B	SELECTIVE PARTS			1
43	10110906	BUSHING THRUST 1.1	SELECTIVE PARTS			1
44	10111003	THRUST WASHER 1.2	SELECTIVE PARTS			1
45	10111201	THRUST WASHER, F	SELECTIVE PARTS			1
46	10112506	THRUST WASHER 1.6	SELECTIVE PARTS			1
47	10112605	THRUST WASHER 1.7	SELECTIVE PARTS			1

HOOK SHAFT & LOWER SHAFT COMPONENTS

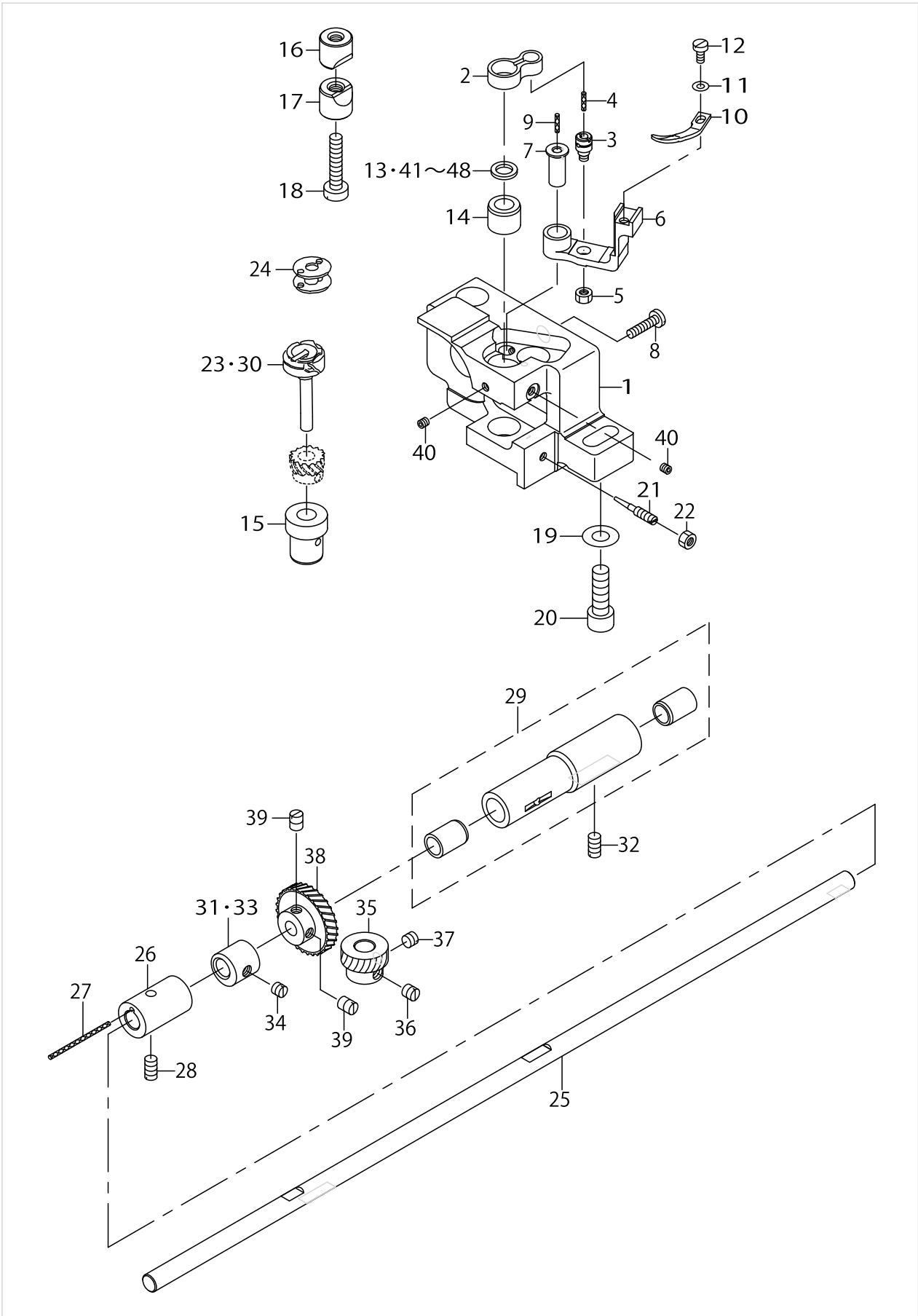

## HOOK SHAFT & LOWER SHAFT COMPONENTS

No.	Parts No.	Parts name	Remarks	Level	Cons	Qty
48	10112704	THRUST WASHER 1.8	SELECTIVE PARTS			1



THREAD TENSION COMPONENTS

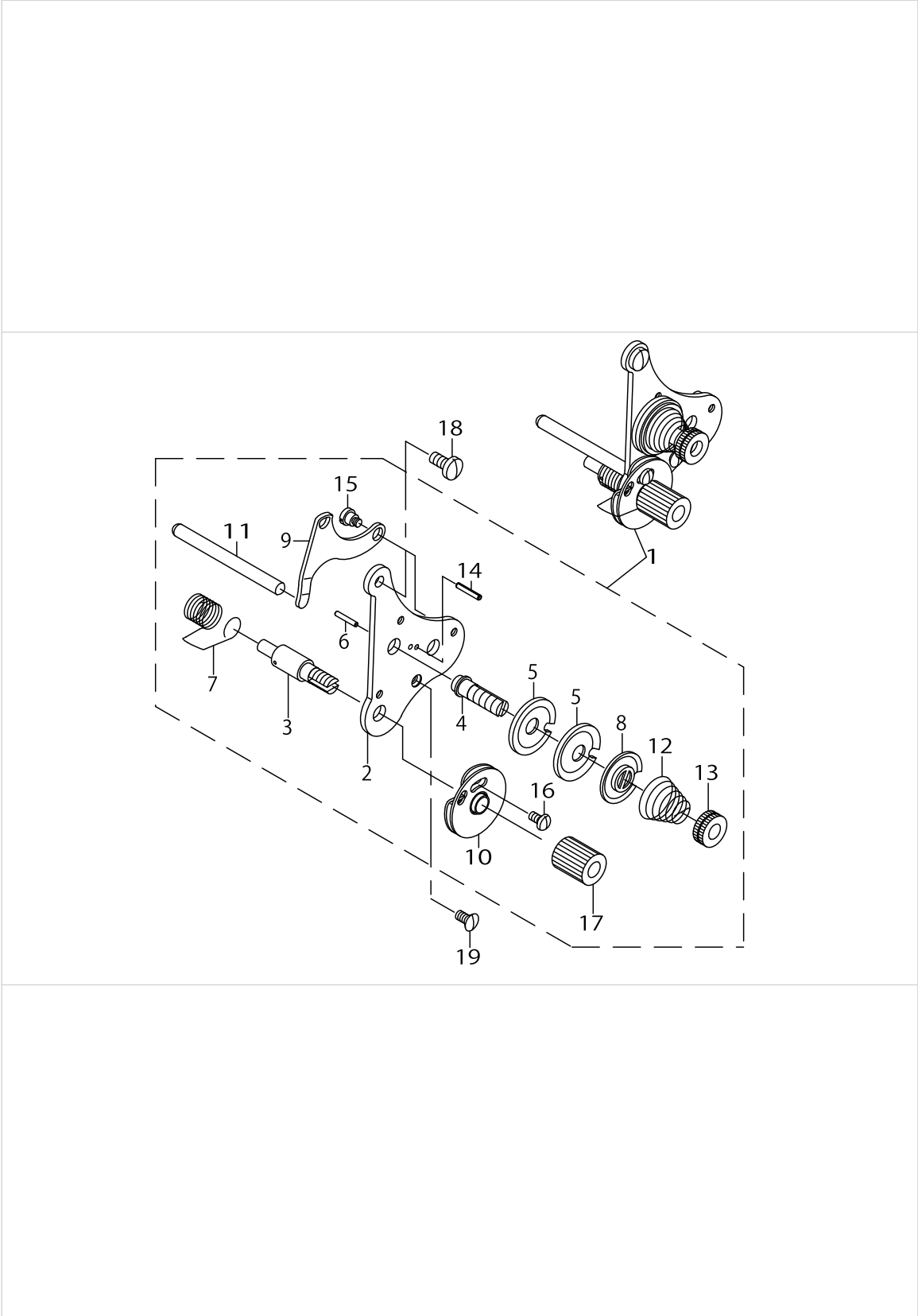

THREAD TENSION COMPONENTS

No.	Parts No.	Parts name	Remarks	Level	Cons	Qty
1	21348156	THREAD TENSION ASM.				1
2	B3121512000	TENSION CONTROLLER BASE		*		1
3	B3123051000	TAKE-UP SPRING STUD		*		1
4	B3124051000	TENSION STUD		*		1
5	B3126051000	TENSION DISC		*		2
6	B3127051000	TENSION RELEASE PIN, SHORT		*		1
7	B3128520000	TENSION SPRING		*		1
8	B3132051000	TENSION DISC HOLDER		*		1
9	B3134051000	TENSION RELEASE LEVER		*		1
10	B31370510A0	TAKE-UP SPRING GUIDE DISC ASM.		*		1
11	B3122053000	TENSION RELEASE BAR		*		1
12	B3129053000	TENSION SPRING		*		1
13	B3125012000	THREAD TENSION NUT		*		1
14	PS0200122K0	SPRING PIN 2.0X12		*		1
15	SD0470281SP	HINGE SCREW D=4.7 H=2.8		*		2
16	SS4080610SP	SCREW 1/8-44 L=6.4		*		1
17	10320208	THRED TENSION STUD NUT		*		1
18	SS7110910TP	SCREW 11/64-40 L= 8.5				1
19	SS2090710TP	SCREW 9/64-40 L=7.2				1

LOWER THREAD WINDER MECHANISM COMPONENTS

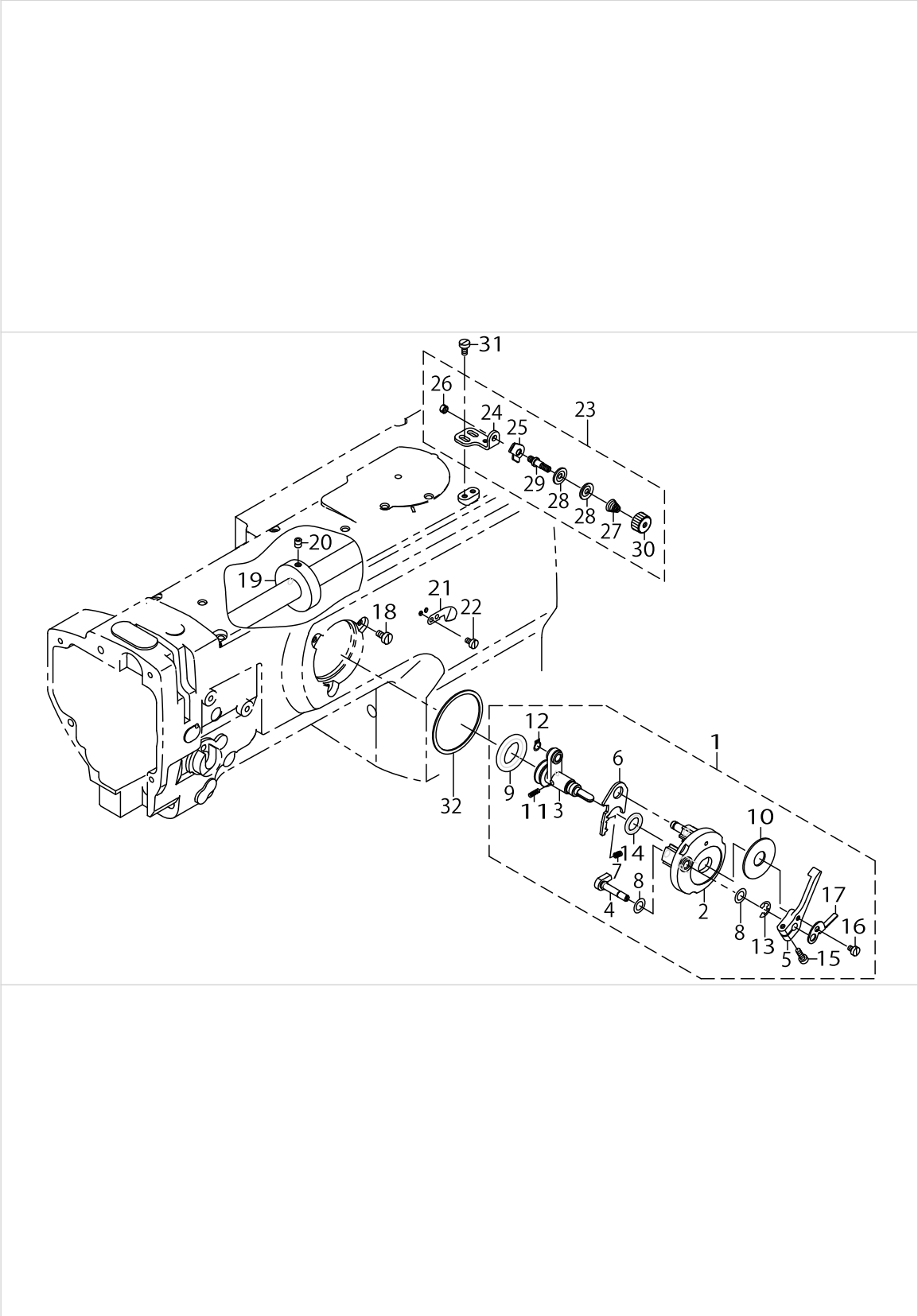

LOWER THREAD WINDER MECHANISM COMPONENTS

No.	Parts No.	Parts name	Remarks	Level	Cons	Qty
1	21357967	BOBBIN DEVICE ASM.				1
2	22537658	BOBBIN FITTING BASIS COMPL.		*		1
3	21357959	BOBIN SHAFT COMPL.		*		1
4	22538151	BOBBIN CAM SHAFT COMPL.		*		1
5	23636202	BOBBIN LEVER		*		1
6	21356001	ADJUSTING PLATE		*		1
7	B152989000CA	PRESSUR FOOT SPRING		*		1
8	10618304	VERTICAL ROLLER WASHER		*		2
9	A321600100A	RUBBER RING		*		1
10	B3205210000	CUSHION		*		1
11	B1148555000	SPRING		*		1
12	RC0560711KP	RETAINING RING		*		1
13	RE0500000K0	E-RING		*		1
14	RO092270200	RUBBER RING		*		1
15	SS7091410SP	SCREW 9/64-40 L=13.5		*		1
16	SS6090520SP	SCREW 9/64-40 L= 5.0		*		1
17	14512503	BOBBIN ADJUSTING PLATE		*		1
18	SS6110810TP	SCREW 11/64-40 L=8				3
19	10704807	BOBBIN FRICTION WHEEL				1
20	SM8050602TP	SCREW M5 L=6				2
21	10502300	THREAD CUTTER				1
22	SS6090620SP	SCREW 9/64-40 L=6				2
23	21355755	LOWER THREAD GUIDE ASM.				1
24	21355706	FITTING BASE		*		1
25	D3162555B00	THREAD GUIDE		*		1
26	NS6110310SP	NUT 11/64-40		*		1
27	D3168555H0B	TENSION SPRING NO.1		*		1
28	B3214047000	BOBBIN WINDER TENSION DISC		*		2
29	21378708	THREAD TENSION POST		*		1
30	11072402	THREAD TENSION NUT		*		1
31	SM6040800SP	SCREW				2
32	22538706	PACKING				1



KNEE LIFTING COMPONENTS

No.	Parts No.	Parts name	Remarks	Level	Cons	Qty
1	21343207	KNEE LIFTER SHAFT BASIS				1
2	SM6061202TP	SCREW M6 L=12				3
3	21342555	KNEE LIFTER SHAFT A ASM.				1
4	21342506	KNEE LIFTER SHAFT A		*		1
5	21342605	KNEE LIFTER SHAFT PIN		*		1
6	21343702	KNEE LIFTER SHAFT A SPRING				1
7	21343801	KNEE LIFTER SPRING RACK				1
8	SM6051602TP	SCREW M5X0.8 L=16				1
9	21342704	KNEE LIFTER SHAFT B				1
10	RE0800000K0	E-SHAPED SNAP RING (8MM)				1
11	21343009	KNEE LIFTER LEVER B				2
12	SM6051602TP	SCREW M5X0.8 L=16				2
13	21342803	KNEE LIFTER LEVER A				1
14	SM6051602TP	SCREW M5X0.8 L=16				1
15	SM8052502TP	SCREW M5X0.8 L=25				1
16	NM6050001SD	NUT M5X0.8				1
17	21342902	KNEE LIFTER LINK				1
18	SD0700451TP	HINGE SCREW D=7 H=4.5				2
19	21343405	KNEE LIFTER CONNECTING PLATE				1
20	SD0700451TP	HINGE SCREW D=7 H=4.5				2
21	21343355	KNEE LIFTER LEVER ASM.				1
22	SM6062502TP	SCREW M6 L=25				2
23	22863252	KNEE LIFTER JOINT ASM.				1
24	B3428521000	PRESSER SPRING		*		1
25	SS7090510SP	SCREW 9/64-40 L= 4.6		*		1
26	22863203	KNEE LIFTER JOINT		*		1
27	22932453	BRACKET ASM.				1
28	22932404	BRACKET		*		1
29	22934707	SCREW		*		2
30	21343157	KNEE PRESS PLATE ASM.				1
31	SM9061203SE	SCREW M6 L=12		*		1
32	21343108	KNEE PRESS LEVER		*		1
33	22934509	KNEE PAD PLATE COVER		*		1
34	22934400	KNEE PAD PLATE RUBBER		*		1
35	22934202	KNEE PAD PLATE		*		1
36	22934301	KNEE PAD PLATE SUPPORT		*		1

BELT COVER & OIL RESERVOIR COMPONENTS

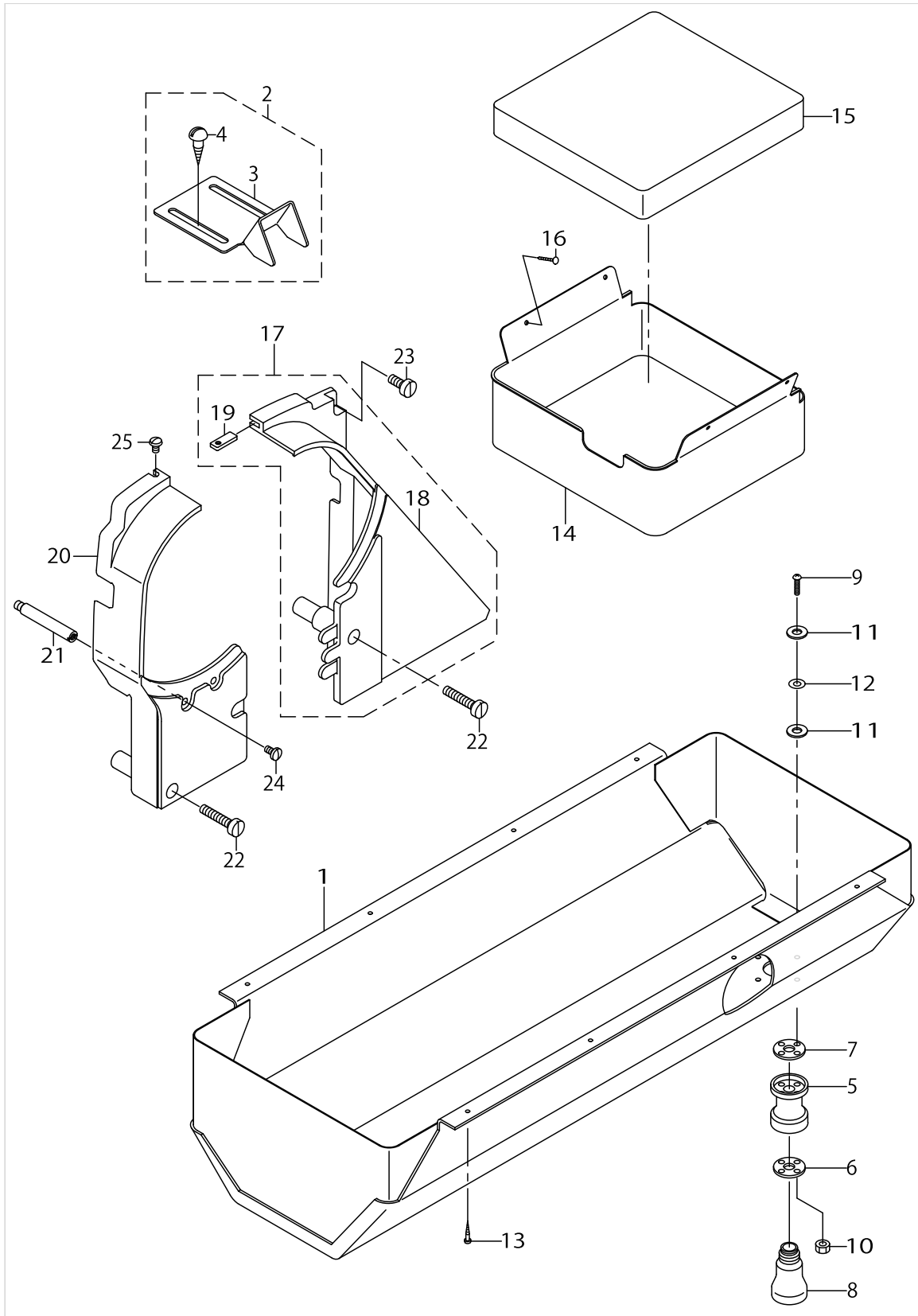

BELT COVER & OIL RESERVOIR COMPONENTS

No.	Parts No.	Parts name	Remarks	Level	Cons	Qty
1	21351457	OIL RESERVOIR ASM.				1
2	10755254	BELT COVER C ASM. (FOR JE)				1
3	10755205	BELT COVER C(JE)		*		1
4	SK3482500SC	WOOD SCREW D=4.8 L=25		*		2
5	B8202205000	OIL MANAGEMENT				1
6	B8111220000	WASHER				1
7	B8112220000	OIL SEAL				1
8	B9121012000	OIL CAN				1
9	SM3031401SE	SCREW M3X0.5 L=14				4
10	NM6030001SC	NUT M3				4
11	10748101	OIL REMOVING SETSCREW PACKING				8
12	WP0320501SC	WASHER M3				4
13	SK3241601SC	WOOD SCREW D=2.4 L=16				8
14	B1839563000	OIL RECEIVING COVER				1
15	B1841563000	OIL DRIP FELT				1
16	B8210012000	CUSHION SET NAIL				4
17	21351150	BELT COVER ASM. (RIGHT)				1
18	21351101	BELT COVER (RIGHT)		*		1
19	21351002	BELT COVER AUXILIARY PLATE		*		1
20	21351200	BELT COVER (LEFT)				1
21	D8232241E00	BELT COVER SUPPORT A				1
22	SS6153040SP	SCREW 15/64-28 L=30				2
23	SS6151440SP	SCREW 15/64-28 L=14				1
24	SS7110840SP	SCREW 11/64-40 L=7.8				1
25	SS5110740TP	SCREW 11/64-40 L= 6.5				1



LUBRICATION COMPONENTS

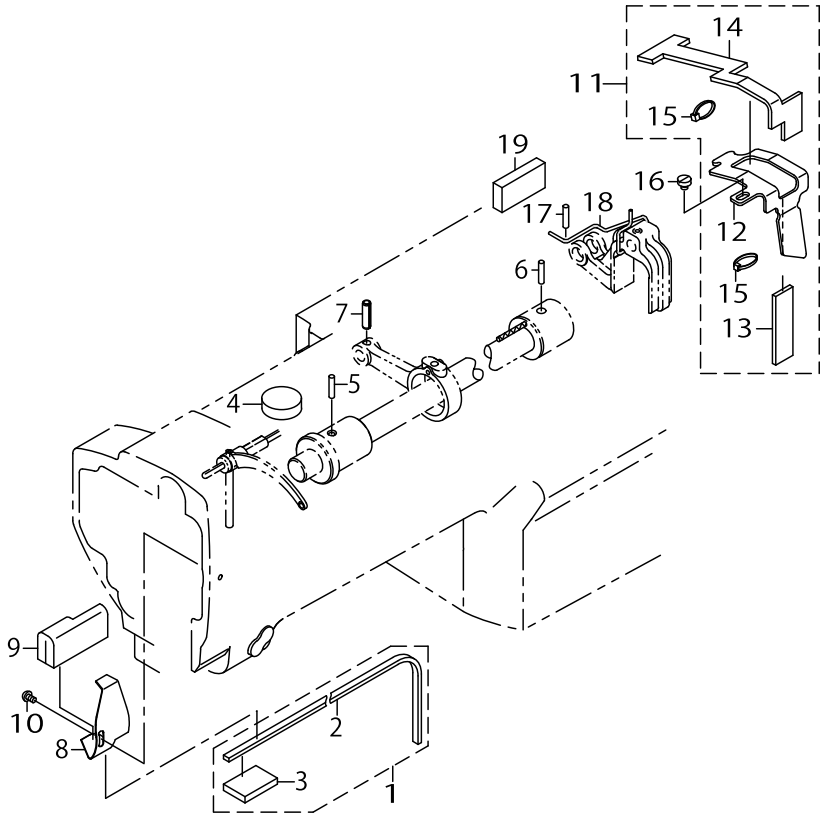

LUBRICATION COMPONENTS

No.	Parts No.	Parts name	Remarks	Level	Cons	Qty
1	21345855	FELT (ASM.)				1
2	21345806	FELT B		*		1
3	21345905	FACE ONCE THROUGH FELT		*		1
4	21346002	FELT				1
5	B1412051000	FELT				1
6	B3517009000	OIL FELT REAR				2
7	PS0500202KP	SPRING PIN 5X20				1
8	B1140051000	TAKE-UP OIL SPLASHER				1
9	21347208	TAKE-UP LUBRICATION FELT				1
10	SS3090610SP	SCREW 9/64-40 L=6				1
11	21346358	FELT SUPPORT ASM.	FOR LU-1508			1
12	21346309	FELT		*		1
13	21346408	FELT		*		1
14	21346507	FEED CHANGE FELT		*		1
15	EA9500B0000	CLIP CV-70S		*		2
16	SS6110480SP	SCREW 11/64-40 L=4.3				1
17	B1412051000	FELT	FOR LU-1508H			1
18	CQ202000000	OIL WICK	FOR LU-1508H			0.21
19	21347307	GREASE RETAINING	FOR LU-1508H			1

ACCESSORIES PARTS COMPONENTS

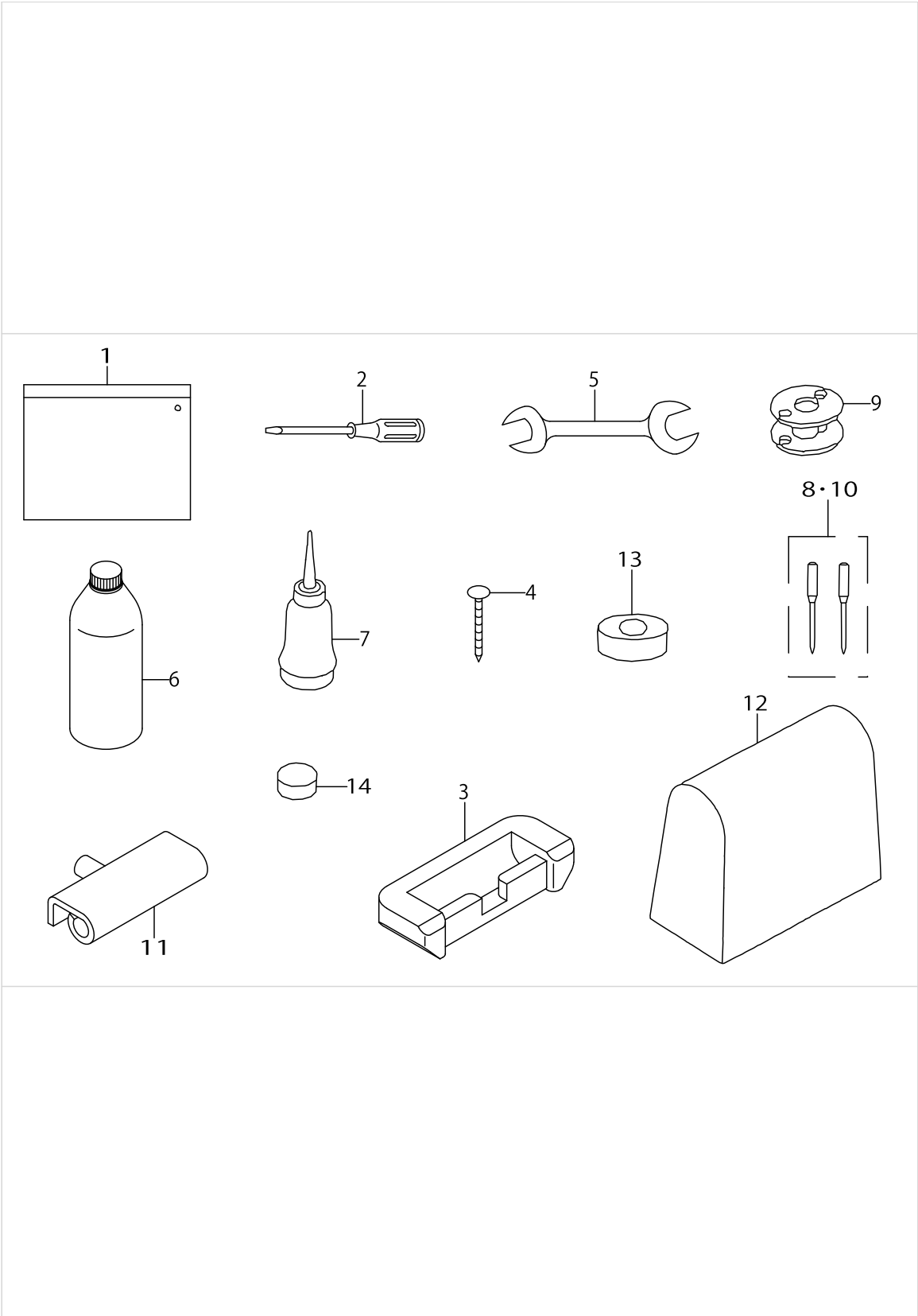

ACCESSORIES PARTS COMPONENTS

No.	Parts No.	Parts name	Remarks	Level	Cons	Qty
1	21413158	ACCESSORY BAG ASM.				1
2	22933006	SCREW DRIVER,LARGE				1
3	11075801	RUBBER SPACER				2
4	B8210012000	CUSHION SET NAIL				8
5	B9113012000	WRENCH (9X10)				1
6	MDFRX2700C0	NEW DEFRIX OIL NO.2(700CC)				1
7	B91210120A0	OILER ASM.				1
8	MC0190R1602	NEEDLE 190R #160-2	FOR LU-1508H			1
9	B9117563000	BOBBIN				1
10	MC372001602	NEEDLE SY3355 #160-2				1
11	B8213125AA0	HINGE ASM.				2
12	10529808	COVER	EXCEPT JAPAN			1
13	B8209012000	RUBBER CUSHION				4
14	B8206012000	FELT CUSHION				4

# THREAD STAND COMPONENTS

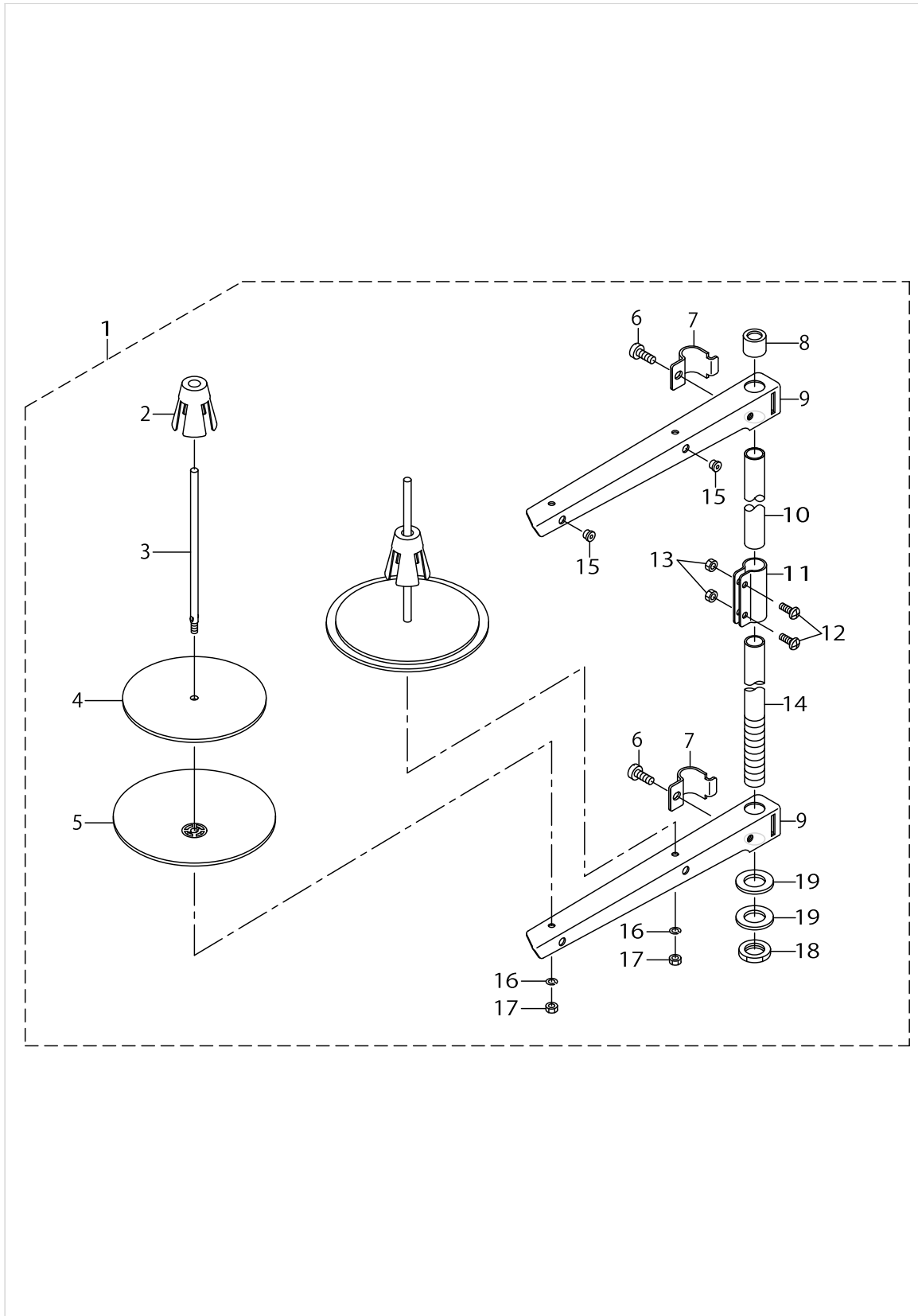

THREAD STAND COMPONENTS

No.	Parts No.	Parts name	Remarks	Level	Cons	Qty
1	22930358	THREAD STAND ASM.				1
2	22931109	SPOOL RETAINER		*		2
3	22931000	SPOOL PIN		*		2
4	22930903	SPOOL REST CUSHION		*		2
5	22930804	SPOOL REST		*		2
6	SM6061610SC	SCREW M6 L=16		*		2
7	22930705	THREAD GUIDE ARM JOINT		*		2
8	22931406	SPOOL REST ROD RUBBER CAP		*		1
9	22930507	SPOOL REST ARM		*		2
10	22930408	SPOOL REST ROD, UPPER		*		1
11	22931307	SPOOL REST ROD JOINT		*		1
12	SM4051405SE	SCREW M5 L=14		*		2
13	NM6050001SE	NUT M5		*		2
14	22930309	SPOOL REST ROD, LOWER		*		1
15	22931208	THREAD GUIDE		*		2
16	WS0510002KN	SPRING WASHER		*		2
17	NM6050001SE	NUT M5		*		2
18	NM6160511SE	NUT M16X1.5		*		1
19	WP1702600S0	WASHER 17X30X2.6		*		2

AUTOMATIC BACK COMPONENTS (FOR LU-1508 OPTIONAL PARTS)

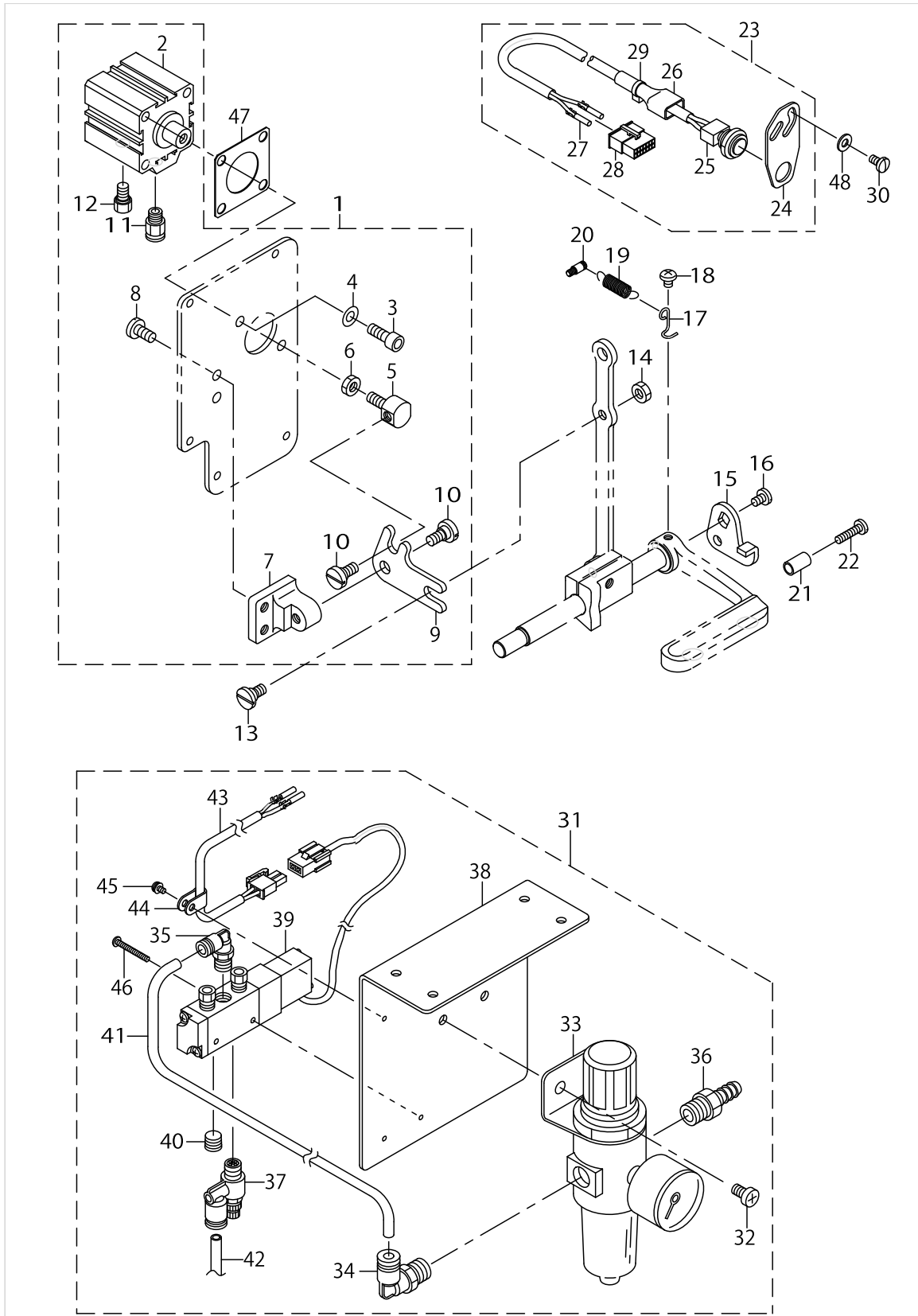

AUTOMATIC BACK COMPONENTS (FOR LU-1508 OPTIONAL PARTS)

No.	Parts No.	Parts name	Remarks	Level	Cons	Qty
1	21348958	WINDOW PLATE ASM.				1
2	PA320150200	JIG CYLINDER		*		1
3	SM6061602TP	SCREW M6 L=16		*		2
4	WP0641601SD	WASHER M6		*		2
5	21348602	CYLINDER CONNECTING SCREW		*		1
6	NM6060003SC	NUT M6		*		1
7	21348503	FITTING BASE		*		1
8	SS7151210SP	SCREW 15/64-28 L=12		*		2
9	21348701	BACKWARD FEED LINK		*		1
10	SD0800352SP	HINGE SCREW D= 8 H= 3.5		*		2
11	PJ301065104	HALF UNION		*		1
12	PX015101000	MUFFLER		*		1
13	SD0800402TP	HINGE SCREW D= 8 H= 4				1
14	NS6150430SP	NUT 15/64-28				1
15	22656102	REVERSE FEED LINK, (1)				1
16	SS7120760SP	SCREW 3/16-28 L= 7.0				1
17	22656003	SPRING SUSPENSION				1
18	SS4120615SP	SCREW 3/16-28 L=6				1
19	13515606	SPRING				1
20	10120004	SPRING SUSPENSION				1
21	11100500	REVERSE FEED LEVER STOPPER				1
22	SS7111810SP	SCREW 11/64-40 L=18				1
23	21348859	TOUCH BUCK SWITCH ASM.				1
24	21348800	SWITCH FITTING PLATE		*		1
25	D1680141EA0	TOUCH BUCK SWITCH ASM		*		1
26	MAT81126T00	2-POLE PLUG COVER		*		1
27	HK03464000B	PIN CONTACT		*		2
28	HK034610140	HOUSING 14P		*		1
29	EA9500B0100	CABLE BAND		*		1
30	SS7110840SP	SCREW 11/64-40 L=7.8				2
31	23105554	AIR COMPONENTS ASM.				1
32	SM4061001SB	SCREW M6 L=10		*		2
33	GAK29007000	FILTER REGULATOR		*		1
34	GAK29009000	ELBOW		*		1
35	GAK29010000	ELBOW B		*		1
36	GAK29011000	NIPPLE		*		1
37	GAK29016000	SPEED CONTROLLER		*		1
38	GAKA1401000	SOLENOID VALVE MOUNTING PLATE		*		1
39	GAKA17040A0	SOLENOID VALVE ASM.		*		1
40	GHP03511000	PLUG 1/8		*		1
41	BT0600401EB	TUBE		*		0.18
42	BT0600401EB	TUBE		*		1.3
43	GAKA17050A0	CORD ASM.		*		1
44	HX001230000	CABLE CLIP		*		1
45	SL4030691SC	SCREW M3X6		*		1
46	SM4032501SB	SCREW M3X0.5 L=25.0		*		2
47	21349105	CYLINDER PACKING				1



AUTOMATIC BACK COMPONENTS (FOR LU-1508 OPTIONAL PARTS)

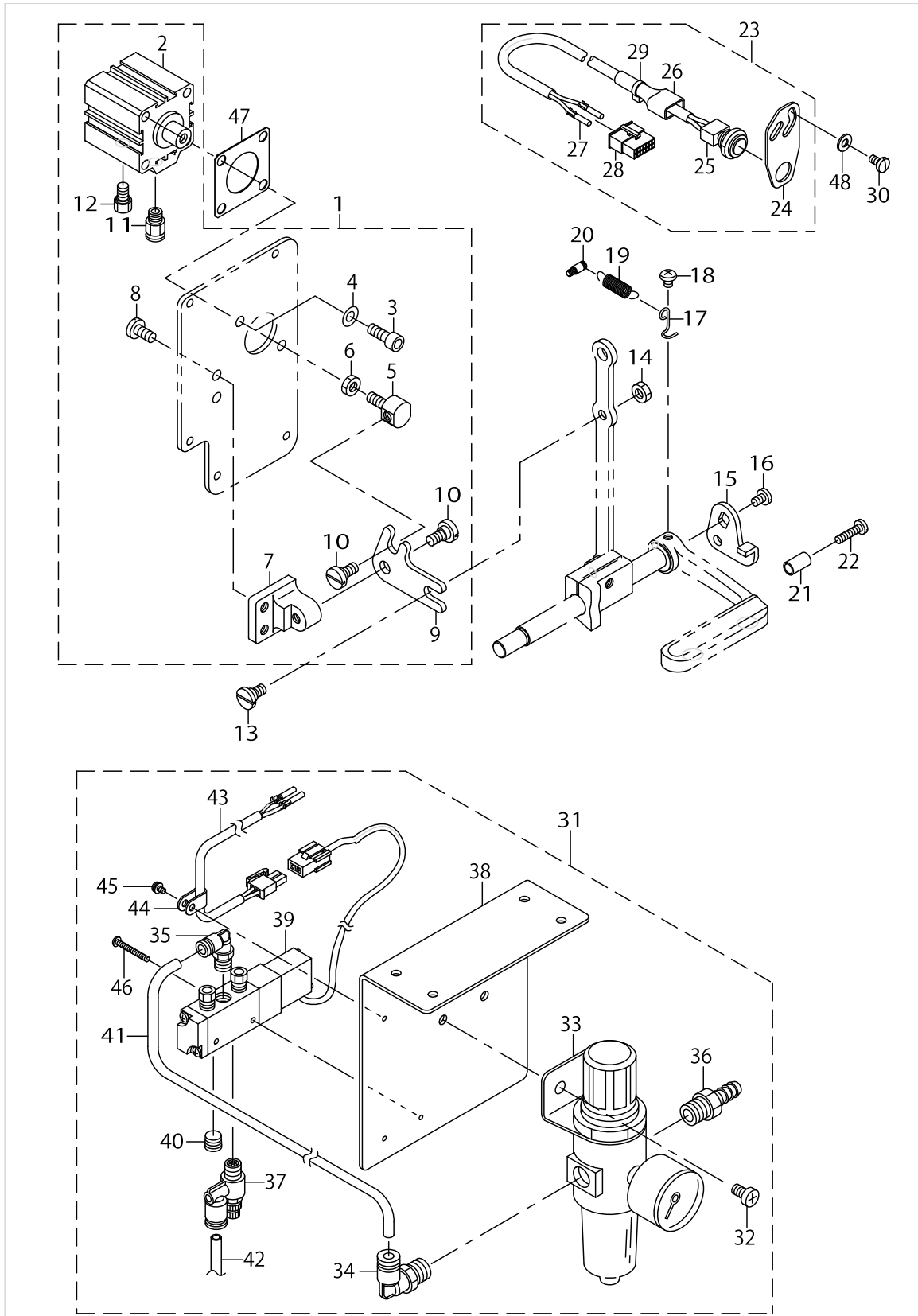

AUTOMATIC BACK COMPONENTS (FOR LU-1508 OPTIONAL PARTS)

No.	Parts No.	Parts name	Remarks	Level	Cons	Qty
48	WP0501016SD	WASHER 5X10.5X1				2

OPTIONAL PARTS (ADDITIONAL SPRING FOR PRESSER BAR)COMPONENTS

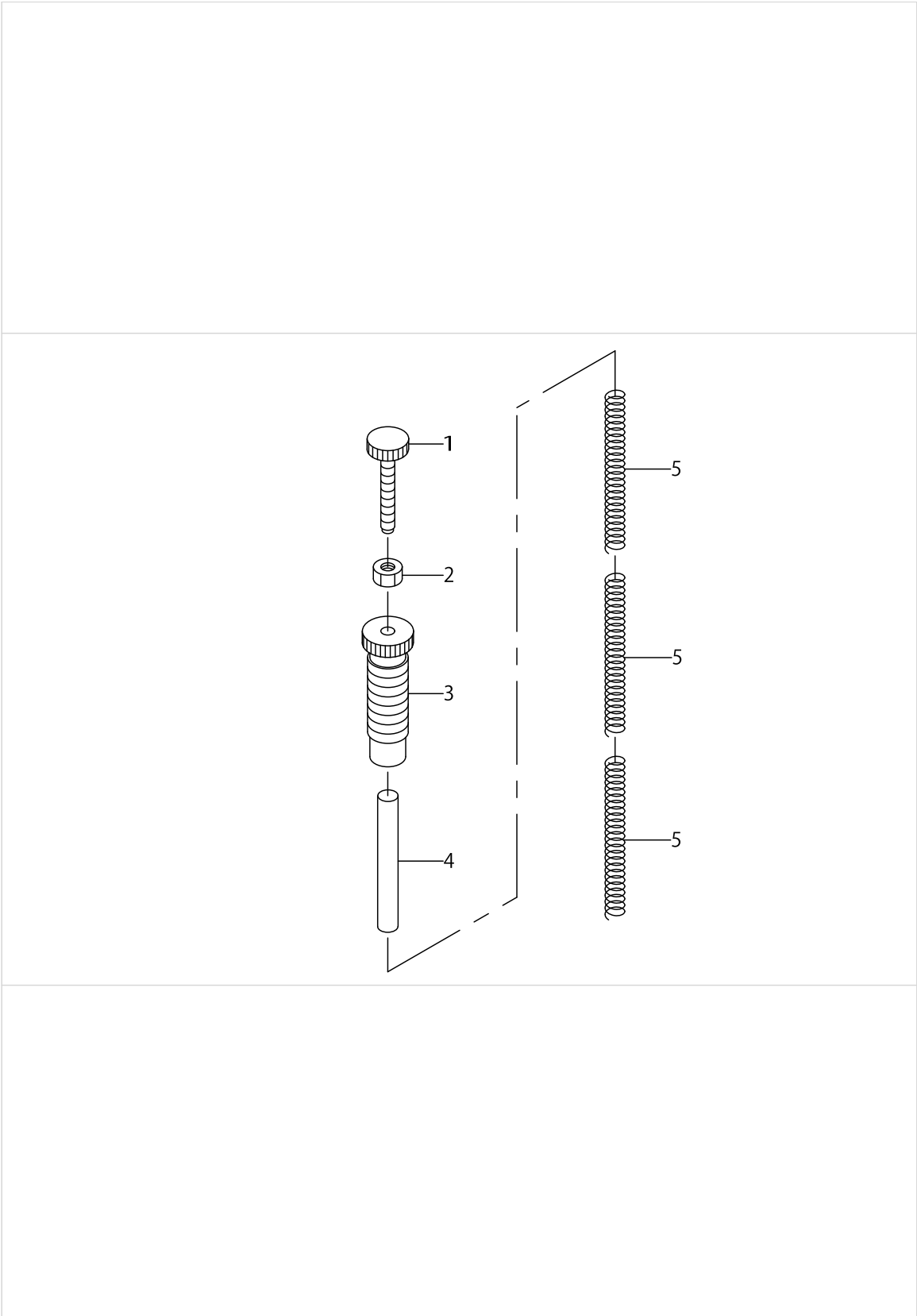

OPTIONAL PARTS (ADDITIONAL SPRING FOR PRESSER BAR)COMPONENTS

No.	Parts No.	Parts name	Remarks	Level	Cons	Qty
1	21006507	ADJUST SCREW B				1
2	NS6110530SP	NUT 11/64-40				1
3	21006408	ADJUST SCREW A				1
4	21342407	GUIDE SHAFT				1
5	21006002	ADJUST SPRING B				3



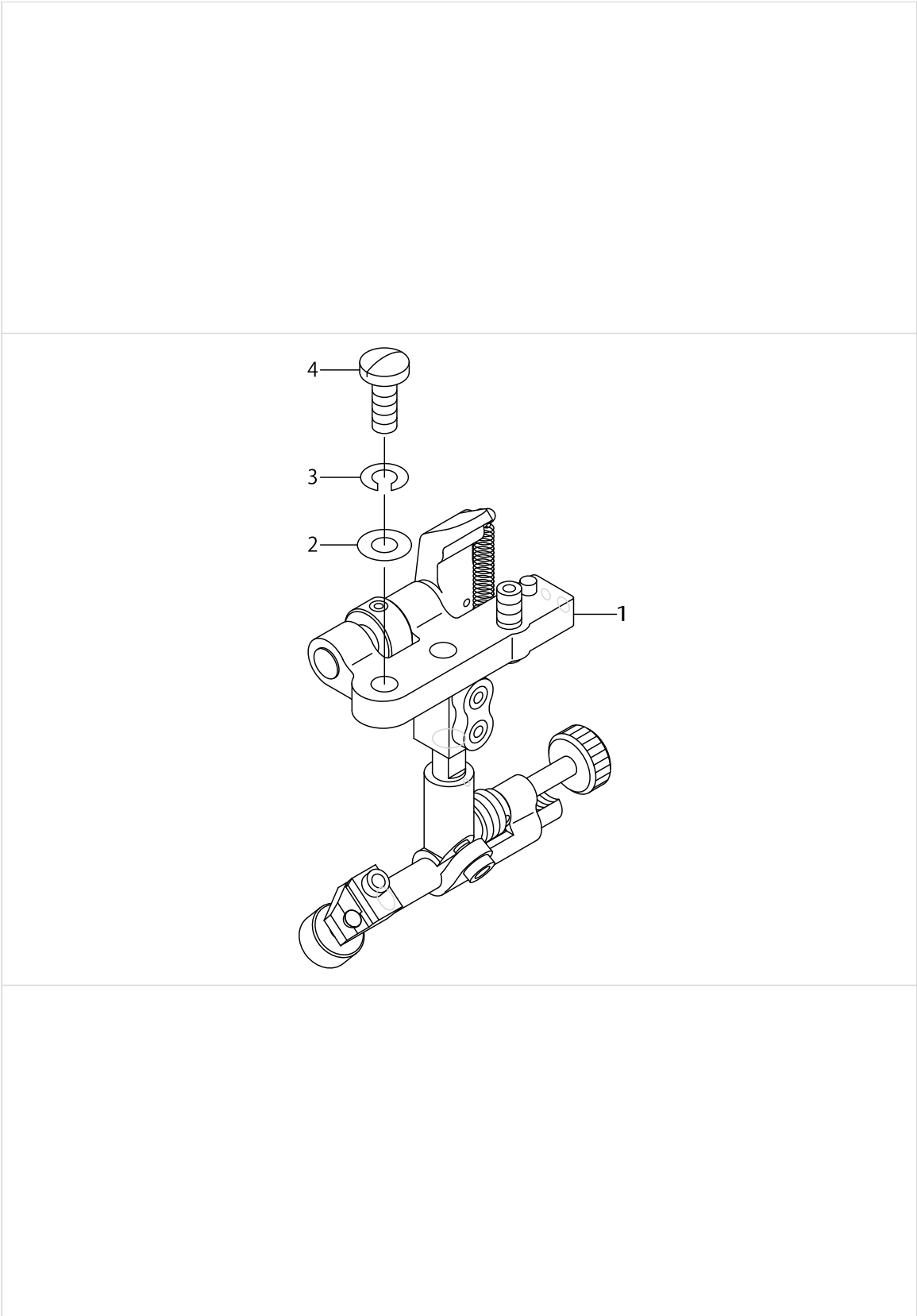





SUSPENSION SQUARE (OPTION) COMPONENTS



SUSPENSION SQUARE (OPTION) COMPONENTS

No.	Parts No.	Parts name	Remarks	Level	Cons	Qty
1	MAH152010A0	RULER				1
2	WP0621016SD	WASHER 6.2X13X1				2
3	WS0610002KN	SPRING WASHER 6.1X12.2X1.5				2
4	SS7151610SP	SCREW 15/64-28 L=16				2

OPTIONAL PARTS COMPONENTS (1)

	Item	Walking foot	Item	Presser foot																																				
	品名	中足	品名	外足																																				
For piping パイピング用	 <p>(Commonly used for every size of presser foot) (各サイズ共用)</p>		<table border="1"> <thead> <tr> <th>Ref.No.</th> <th>Part No.</th> <th>Size(mm)</th> <th>Ref.No.</th> <th>Part No.</th> </tr> </thead> <tbody> <tr> <td>1</td> <td>B1478-245-000</td> <td>4.4mm(5/32)</td> <td>12</td> <td>B1530-245-0AC</td> </tr> <tr> <td></td> <td></td> <td>4.8mm(3/16)</td> <td>13</td> <td>B1530-245-0AD</td> </tr> <tr> <td></td> <td></td> <td>6.4mm(1/4)</td> <td>14</td> <td>B1530-245-0AF</td> </tr> <tr> <td></td> <td></td> <td>7.9mm(5/16)</td> <td>15</td> <td>B1530-245-0AH</td> </tr> <tr> <td></td> <td></td> <td>9.5mm(3/8)</td> <td>16</td> <td>B1530-245-0AK</td> </tr> </tbody> </table>		Ref.No.	Part No.	Size(mm)	Ref.No.	Part No.	1	B1478-245-000	4.4mm(5/32)	12	B1530-245-0AC			4.8mm(3/16)	13	B1530-245-0AD			6.4mm(1/4)	14	B1530-245-0AF			7.9mm(5/16)	15	B1530-245-0AH			9.5mm(3/8)	16	B1530-245-0AK						
			Ref.No.	Part No.	Size(mm)	Ref.No.	Part No.																																	
			1	B1478-245-000	4.4mm(5/32)	12	B1530-245-0AC																																	
					4.8mm(3/16)	13	B1530-245-0AD																																	
					6.4mm(1/4)	14	B1530-245-0AF																																	
					7.9mm(5/16)	15	B1530-245-0AH																																	
			9.5mm(3/8)	16	B1530-245-0AK																																			
			<table border="1"> <thead> <tr> <th>Size(mm)</th> <th>Ref.No.</th> <th>Part No.</th> <th>Size(mm)</th> <th>Ref.No.</th> <th>Part No.</th> </tr> </thead> <tbody> <tr> <td>4.4mm(5/32)</td> <td>2</td> <td>B1478-245-000</td> <td>4.4mm(5/32)</td> <td>17</td> <td>B1531-245-0AC</td> </tr> <tr> <td>4.8mm(3/16)</td> <td>3</td> <td>B1479-245-00D</td> <td>4.8mm(3/16)</td> <td>18</td> <td>B1531-245-0AD</td> </tr> <tr> <td>6.4mm(1/4)</td> <td>4</td> <td>B1479-245-00F</td> <td>6.4mm(1/4)</td> <td>19</td> <td>B1531-245-0AF</td> </tr> <tr> <td>7.9mm(5/16)</td> <td>5</td> <td>B1479-245-00H</td> <td>7.9mm(5/16)</td> <td>20</td> <td>B1531-245-0AH</td> </tr> <tr> <td>9.5mm(3/8)</td> <td></td> <td></td> <td>9.5mm(3/8)</td> <td></td> <td></td> </tr> </tbody> </table>		Size(mm)	Ref.No.	Part No.	Size(mm)	Ref.No.	Part No.	4.4mm(5/32)	2	B1478-245-000	4.4mm(5/32)	17	B1531-245-0AC	4.8mm(3/16)	3	B1479-245-00D	4.8mm(3/16)	18	B1531-245-0AD	6.4mm(1/4)	4	B1479-245-00F	6.4mm(1/4)	19	B1531-245-0AF	7.9mm(5/16)	5	B1479-245-00H	7.9mm(5/16)	20	B1531-245-0AH	9.5mm(3/8)			9.5mm(3/8)		
			Size(mm)	Ref.No.	Part No.	Size(mm)	Ref.No.	Part No.																																
			4.4mm(5/32)	2	B1478-245-000	4.4mm(5/32)	17	B1531-245-0AC																																
4.8mm(3/16)			3	B1479-245-00D	4.8mm(3/16)	18	B1531-245-0AD																																	
6.4mm(1/4)			4	B1479-245-00F	6.4mm(1/4)	19	B1531-245-0AF																																	
7.9mm(5/16)	5	B1479-245-00H	7.9mm(5/16)	20	B1531-245-0AH																																			
9.5mm(3/8)			9.5mm(3/8)																																					
		<table border="1"> <thead> <tr> <th>Size(mm)</th> <th>Ref.No.</th> <th>Part No.</th> <th>Size(mm)</th> <th>Ref.No.</th> <th>Part No.</th> </tr> </thead> <tbody> <tr> <td>4.4mm(5/32)</td> <td>6</td> <td>B1474-245-00C</td> <td>4.4mm(5/32)</td> <td>21</td> <td>B1527-245-0AC</td> </tr> <tr> <td>4.8mm(3/16)</td> <td>7</td> <td>B1474-245-00D</td> <td>4.8mm(3/16)</td> <td>22</td> <td>B1527-245-0AD</td> </tr> <tr> <td>6.4mm(1/4)</td> <td>8</td> <td>B1474-245-00F</td> <td>6.4mm(1/4)</td> <td>23</td> <td>B1527-245-0AF</td> </tr> <tr> <td>7.9mm(5/16)</td> <td>9</td> <td>B1474-245-00H</td> <td>7.9mm(5/16)</td> <td>24</td> <td>B1527-245-0AH</td> </tr> <tr> <td>9.5mm(3/8)</td> <td>10</td> <td>B1474-245-00K</td> <td>9.5mm(3/8)</td> <td>25</td> <td>B1527-245-0AK</td> </tr> </tbody> </table>		Size(mm)	Ref.No.	Part No.	Size(mm)	Ref.No.	Part No.	4.4mm(5/32)	6	B1474-245-00C	4.4mm(5/32)	21	B1527-245-0AC	4.8mm(3/16)	7	B1474-245-00D	4.8mm(3/16)	22	B1527-245-0AD	6.4mm(1/4)	8	B1474-245-00F	6.4mm(1/4)	23	B1527-245-0AF	7.9mm(5/16)	9	B1474-245-00H	7.9mm(5/16)	24	B1527-245-0AH	9.5mm(3/8)	10	B1474-245-00K	9.5mm(3/8)	25	B1527-245-0AK	
		Size(mm)	Ref.No.	Part No.	Size(mm)	Ref.No.	Part No.																																	
		4.4mm(5/32)	6	B1474-245-00C	4.4mm(5/32)	21	B1527-245-0AC																																	
		4.8mm(3/16)	7	B1474-245-00D	4.8mm(3/16)	22	B1527-245-0AD																																	
		6.4mm(1/4)	8	B1474-245-00F	6.4mm(1/4)	23	B1527-245-0AF																																	
		7.9mm(5/16)	9	B1474-245-00H	7.9mm(5/16)	24	B1527-245-0AH																																	
9.5mm(3/8)	10	B1474-245-00K	9.5mm(3/8)	25	B1527-245-0AK																																			
 <p>(With teeth) (歯付き)</p>	 <p>(With teeth) (歯付き)</p>	<table border="1"> <thead> <tr> <th>Ref.No.</th> <th>Part No.</th> <th>Ref.No.</th> <th>Part No.</th> </tr> </thead> <tbody> <tr> <td>11</td> <td>103-38309</td> <td>26</td> <td>B1525-563-SA0</td> </tr> </tbody> </table>		Ref.No.	Part No.	Ref.No.	Part No.	11	103-38309	26	B1525-563-SA0																													
		Ref.No.	Part No.	Ref.No.	Part No.																																			
11	103-38309	26	B1525-563-SA0																																					

OPTIONAL PARTS COMPONENTS (1)

No.	Parts No.	Parts name	Remarks	Level	Cons	Qty
1	B1478245000	INNER PRESSER				1
2	B1478245000	INNER PRESSER				1
3	B147924500D	CENTER PRESSER FOOT 3/16				1
4	B147924500F	BACK CUT INNER PRESSER 1/4				1
5	B147924500H	BACK CUT INNER PRESSER 5/16				1
6	B147424500C	INNER PRESSER 5/32				1
7	B147424500D	INNER PRESSER (BLADE) 3/16				1
8	B147424500F	WALKING FOOT, F				1
9	B147424500H	INNER PRESSER 5/16				1
10	B147424500K	CENTER PRESSER FOOT 3/8				1
11	10338309	UPPER FEED FOOT				1
12	B15302450AC	OUTER PRESSER ASM. 5/32				1
13	B15302450AD	OUTER PRESSER FOOT ASM.,3/16.				1
14	B15302450AF	OUTER PRESSER FOOT 1/4 ASM.				1
15	B15302450AH	OUTER PRESSER FOOT ASM. (5/16)				1
16	B15302450AK	OUTER PRESSER FOOT ASM. (3/8)				1
17	B15312450AC	OUTER PRESSER FOOT ASM. (5/32)				1
18	B15312450AD	OUTER PRESSER FOOT ASM. 3/16				1
19	B15312450AF	OUTER PRESSER ASM., 1/4				1
20	B15312450AH	FEEDING FRAME 5/16 ASM.				1
21	B15272450AC	OUTER PRESSER FOOT ASM. 5/32				1
22	B15272450AD	FEEDING FRAME 3/16 ASM.				1
23	B15272450AF	OUTER PRESSER ASM., 1/4				1
24	B15272450AH	OUTER PRESSER FOOT ASM. 5/16				1
25	B15272450AK	OUTER PRESSER FOOT ASM.3/8				1
26	B1525563SA0	PRESSER FOOT ASM.				1





OPTIONAL PARTS COMPONENTS (2)

No.	Parts No.	Parts name	Remarks	Level	Cons	Qty
1	MAQ09307000	WALKING FOOT				1
2	MAN10452000	UPPER FEED FOOT				1
3	B147624500A	INNER PRESSER				1
4	10325306	WALKING FOOT				1
5	10326205	UPPER FEED FOOT				1
6	B1470245000	WALKING FOOT				1
7	MAQ093080A0	PRESSER FOOT ASM.				1
8	B15292450AA	OUTER PRESSER FOOT ASM., RIGHT				1
9	10325157	PRESSER FOOT ASM.				1
10	10326304	PRESSER FOOT				1
11	B15242450A0	PRESSER FOOT ASM.				1
12	B1109562A00	THROAT PLATE (WIDE)				1
13	B1109563C00	THROAT PLATE				1
14	B1613562A00	FEED (WIDE)				1
15	B1613563C00	FEED DOG C				1
16	B1840051000	FEED DRIVING ECCENTRIC				1
17	21378104	FEED DRIVING ECCENTRIC				1



## HOW TO MAKE USE OF THIS PARTS LIST

### 1.Explanation of codes

1)"\*"mark.....means this part is changed from the previous parts book.

As to the details of the change, refer to the "List for information of change".

2)"#01".....refer to "Note" explanation at bottom of page.

### 2.Codes on the "Qty" column

- Each numeral indicates the number of parts required.
- "0.1" and "2.5" indicate the length (in meters) of the respective parts.

3.Parentheses mean that the corresponding part is a subpart that constructs an assembly part.

4.Dotted lines on the Figures indicate assembly parts.

### 1."注記"欄の記号説明

1) "\*"印.....前回のパーツブックに比較して今回変更された部品を意味します。

変更内容は、"変更情報リスト"を参照してください。

2) "#01".....ページ下の"注記"の説明を参照してください。

2.数量欄の数字は、個数を表し、0.1、2.5等の数値は、長さ（単位メートル）を表します。

3.数量欄の（ ）は、組部品を構成している子部品であることを意味します。

4.イラストページの-----枠は、組構成であることを意味します。

# NUMERICAL INDEX OF PARTS

PART NO	PAGE	REF NO.	PART NO	PAGE	REF NO.	PART NO	PAGE	REF NO.
10004109	2	45	11075801	34	3	21337001	16	68
10083202	16	57	11100500	16	85	21337100	16	69
10109700	20	13·41~ 48	11100500	38	21	21337209	14	38·39
10109809	20	13·41~ 48	11272614	16	83	21337308	14	33
10109908	20	16	13514310	10	29	21337407	14	26
10110906	20	13·41~ 48	13515606	38	19	21337506	14	23
10111003	20	13·41~ 48	13789201	16	82	21337605	14	35
10111102	20	13·41~ 48	14512503	26	17	21337704	14	24
10111201	20	13·41~ 48	17912106	2	26	21337803	14	27
10112407	20	13·41~ 48	21006002	42	5	21337902	14	31
10112506	20	13·41~ 48	21006408	42	3	21338009	14	36
10112605	20	13·41~ 48	21006507	42	1	21338108	14	38·39
10112704	22	13·41~ 48	21331202	2	11	21338207	16	54
10120004	16	81	21331400	2	4	21338306	14	29
10120004	38	20	21331558	2	1	21338603	8	18
10122000	16	90	21331608	2	18	21338702	8	16
10205201	14	20	21331756	2	8	21338801	8	20
10308609	8	11	21331806	2	12	21338900	8	22
10320208	24	17	21332002	2	13	21339007	8	28
10325157	48	9	21332200	2	46	21339056	8	27
10325306	48	4	21332309	2	16	21339106	4	8
10326205	48	5	21332507	4	13·57	21339205	8	26
10326304	48	10	21332606	6	13·57	21339304	8	25
10337905	12	56	21332705	4	1	21339403	8	2
10338309	46	11	21332903	6	29·58	21339502	4	16
10502300	26	21	21333000	4	2	21339908	10	12
10503605	4	38	21333109	4	18	21340104	10	31
10509701	10	22	21333406	6	59	21340203	10	36
10529808	34	12	21333505	4	31	21340401	10	1
10618304	26	8	21333604	20	25	21340500	10	2
10704807	26	19	21333703	6	48	21340807	10	19
10704906	4	27	21334008	4	29·58	21340906	10	42
10748101	30	11	21334701	20	15	21341003	10	40
10755205	30	3	21335005	20	1	21341052	10	39
10755254	30	2	21336003	14	2	21341151	10	46
11006509	12	49	21336052	14	1	21341300	10	28
11009909	14	44	21336300	16	60·61	21341904	10	4
11052701	14	46	21336409	16	60·61	21342407	42	4
11072402	26	30	21336508	4	21	21342506	28	4
			21336557	4	20	21342555	28	3
			21336607	16	49	21342605	28	5
			21336656	16	48	21342704	28	9
			21336706	16	53	21342803	28	13
			21336805	14	41·42	21342902	28	17
			21336904	14	41·42	21343009	28	11

## NUMERICAL INDEX OF PARTS

PART NO	PAGE	REF NO.	PART NO	PAGE	REF NO.	PART NO	PAGE	REF NO.
21343108	28	32	21355805	2	20	22931000	36	3
21343157	28	30	21355904	2	6	22931109	36	2
21343207	28	1	21356001	26	6	22931208	36	15
21343355	28	21	21357959	26	3	22931307	36	11
21343405	28	19	21357967	26	1	22931406	36	8
21343504	12	48	21364104	14	10	22932404	28	28
21343702	28	6	21378104	48	17	22932453	28	27
21343801	28	7	21378302	10	5	22933006	34	2
21345806	32	2	21378302	14	13	22934202	28	35
21345855	32	1	21378500	20	14	22934301	28	36
21345905	32	3	21378708	26	29	22934400	28	34
21346002	32	4	21408505	2	25	22934509	28	33
21346309	32	12	21408554	2	24	22934707	28	29
21346358	32	11	21413158	34	1	23105554	38	31
21346408	32	13	22537658	26	2	23636202	26	5
21346507	32	14	22538151	26	4	A321600100A	26	9
21347109	10	13	22538706	26	32	B1109562A00	48	12
21347208	32	9	22602601	2	47	B1109563000	2	36
21347307	32	19	22604300	4	25	B1109563C00	48	13
21347406	8	30	22604904	6	61	B1111563000	2	34
21348156	24	1	22609309	14	15	B1114232000	2	31
21348503	38	7	22609408	14	12	B1129051000	2	22
21348602	38	5	22610505	16	66	B1132521000	2	27
21348701	38	9	22611602	6	51	B1140051000	32	8
21348800	38	24	22611651	6	50	B1148555000	26	11
21348859	38	23	22656003	38	17	B1203512000	4	26
21348958	38	1	22656102	38	15	B1210051000	4	11
21349105	38	47	22814909	8	33	B1214019000	4	32
21349303	16	87	22814909	10	38	B1305055000A	4	33
21349600	2	38	22814909	18	95	B1307055000	4	34
21349709	2	39	22863203	28	26	B1308055000	4	35
21350004	12	53	22863252	28	23	B1309055000	4	36
21351002	30	19	22877609	2	9	B1310055000	4	37
21351101	30	18	22904106	10	7	B1312563000A	4	44
21351150	30	17	22904106	14	18	B1313055000	4	47
21351200	30	20	22904155	10	6	B1314055000	4	39
21351457	30	1	22904155	14	17	B1401053000	8	7
21352505	4	23	22912109	14	47	B1410771000	8	24
21352604	16	58	22930309	36	14	B1411053000	8	8
21352703	16	56	22930358	36	1	B1412051000	8	10
21352802	16	75	22930408	36	10	B1412051000	32	17
21352901	16	71	22930507	36	9	B1414232000	8	23
21353008	6	55	22930705	36	7	B1414555000	10	21
21355706	26	24	22930804	36	5	B1418761000	16	50
21355755	26	23	22930903	36	4	B1420563000	8	1

# NUMERICAL INDEX OF PARTS

PART NO	PAGE	REF NO.	PART NO	PAGE	REF NO.	PART NO	PAGE	REF NO.
B1462053000	10	47	B1611055000	16	88	B3517009000	32	6
B1465053000	10	23	B1613562A00	48	14	B8111220000	30	6
B1466563000	10	24	B1613563C00	48	15	B8112220000	30	7
B14670530A0	10	25	B1639051000	4	46	B8202205000	30	5
B1467563000	8	14	B1802563000A	20	26	B8206012000	34	14
B1468053000	10	26	B18035150A0	20	29	B8209012000	34	13
B1470241H00	12	51	B1816051000	20	38	B8210012000	30	16
B1470245000	48	6	B1817051000	20	35	B8210012000	34	4
B1471241H00	12	52	B1820563000	20	2	B8213125AA0	34	11
B147424500C	46	6	B1821051000	20	3	B9113012000	34	5
B147424500D	46	7	B1822563000	20	6	B9117563000	20	24
B147424500F	46	8	B1823051000	20	7	B9117563000	34	9
B147424500H	46	9	B1824563000	20	10	B9121012000	30	8
B147424500K	46	10	B18305630A0	20	23·30	B91210120A0	34	7
B147624500A	48	3	B1830563BA0	20	23·30	BT0600401EB	38	42
B1478245000	46	2	B1839563000	30	14	CM300200001	2	43·44
B147924500D	46	3	B1840051000	20	33	CM3002000B1	2	43·44
B147924500F	46	4	B1840051000	48	16	CM300200101	2	41·42
B147924500H	46	5	B184005100A	20	31·33	CM3002001A1	2	41·42
B1501241H00	12	58	B1841563000	30	15	CQ202000000	4	19
B1502246000	10	44	B1843563000	20	21	CQ202000000	8	4
B1510141H00	12	57	B185351200CA	8	3	CQ202000000	14	51
B1511555000	10	43	B1905241H00	4	4	CQ202000000	16	51
B15242450A0	48	11	B1905563000	4	3	CQ202000000	20	27
B1525241H00	12	55	B1906051000	4	5	CQ202000000	32	18
B1525241HA0	12	54	B1907051000	4	6	CQ303000000	4	9
B1525563SA0	46	26	B2507372000	16	77	CQ505000000	4	12
B15272450AC	46	21	B3016141H00	10	15	CS1201010SH	16	62
B15272450AD	46	22	B3025141H00A	16	91	CS1201011SH	16	63
B15272450AF	46	23	B3121512000	24	2	D1455055B00	10	33
B15272450AH	46	24	B3122053000	24	11	D1456055B00	10	32
B15272450AK	46	25	B3123051000	24	3	D1680141EA0	38	25
B15292450AA	48	8	B3124051000	24	4	D2461481C00	16	76
B152989000CA	26	7	B3125012000	24	13	D3162555B00	26	25
B15302450AC	46	12	B3126051000	24	5	D3168555H0B	26	27
B15302450AD	46	13	B3127051000	24	6	D8232241E00	30	21
B15302450AF	46	14	B3128520000	24	7	EA9500B0000	10	14
B15302450AH	46	15	B3129053000	24	12	EA9500B0000	32	15
B15302450AK	46	16	B3132051000	24	8	EA9500B0100	8	31
B15312450AC	46	17	B3134051000	24	9	EA9500B0100	38	29
B15312450AD	46	18	B31370510A0	24	10	GAK29007000	38	33
B15312450AF	46	19	B3138512000	2	32	GAK29009000	38	34
B15312450AH	46	20	B3205210000	26	10	GAK29010000	38	35
B1604012000A	14	7	B3214047000	26	28	GAK29011000	38	36
B1604051000	14	3	B3428521000	28	24	GAK29016000	38	37

NUMERICAL INDEX OF PARTS

PART NO	PAGE	REF NO.	PART NO	PAGE	REF NO.	PART NO	PAGE	REF NO.
GAKA1401000	38	38	SD0380551SL	2	28	SS5110740TP	30	25
GAKA17040A0	38	39	SD0470281SP	24	15	SS6090520SP	26	16
GAKA17050A0	38	43	SD0640322TP	4	42	SS6090620SP	26	22
GHP03511000	38	40	SD0640701SP	10	16	SS6090810SP	20	12
HK034610140	38	28	SD0700451TP	28	20	SS6090910SP	16	79
HK03464000B	38	27	SD0800352SP	38	10	SS6090910TP	12	50
HX001230000	38	44	SD0800402TP	14	34	SS6091022TP	8	19
MAH152010A0	44	1	SD0800402TP	38	13	SS6110480SP	32	16
MAN10452000	48	2	SD0800481SP	10	45	SS6110520TP	16	89
MAQ09307000	48	1	SD0900701TP	14	21	SS6110810TP	26	18
MAQ093080A0	48	7	SD1000801SH	16	55	SS6111610SP	14	37
MAT81126T00	38	26	SK3241601SC	30	13	SS6120930TP	16	67
MC0190R1600	8	13-32	SK3482500SC	30	4	SS6121210TP	16	92
MC0190R1602	34	8-10	SL4030691SC	38	45	SS6121610TP	14	16
MC372001600	8	13-32	SM3031401SE	30	9	SS6121860SP	14	43
MC372001602	34	8-10	SM4032501SB	38	46	SS6151440SP	30	23
MDFRX2700C0	34	6	SM4051405SE	36	12	SS6151780SP	10	27
NM6030001SC	30	10	SM4061001SB	38	32	SS6151920SP	10	30
NM6050001SD	28	16	SM6040800SP	26	31	SS6152440SP	8	29
NM6050001SE	36	17	SM6051602TP	28	14	SS6153012TP	16	74
NM6060003SC	38	6	SM6061202TP	28	2	SS6153040SP	20	18
NM6160511SE	36	18	SM6061602TP	38	3	SS6153040SP	30	22
NS6110310SP	26	26	SM6061610SC	36	6	SS6661110SP	4	40
NS6110420SP	2	30	SM6061802TP	14	40	SS7080510TP	8	12
NS6110420SP	20	22	SM6062502TP	28	22	SS7090510SP	28	25
NS6110530SP	10	35	SM6082502TP	20	20	SS7090520TP	2	33
NS6110530SP	42	2	SM8050502TP	14	6	SS7090610SP	14	30
NS6150310SP	16	94	SM8050602TP	26	20	SS7090910SP	8	9
NS6150430SP	38	14	SM8050612TP	16	52	SS7090910TP	14	32
NS6680320SP	14	22	SM8052502TP	28	15	SS7091410SP	26	15
PA320150200	38	2	SM8060602TP	4	28	SS7110510SP	10	20
PJ301065104	38	11	SM8080802TP	8	21	SS7110710SP	6	56
PS0200122K0	24	14	SM8080812TP	4	15	SS7110710SP	16	70
PS0500202KP	32	7	SM9061203SE	28	31	SS7110830SP	8	17
PX015101000	38	12	SM9062250SC	10	37	SS7110840SP	30	24
RC0560711KP	26	12	SS2090710TP	2	29	SS7110840SP	38	30
RE0400000K0	16	78	SS2090710TP	24	19	SS7110910TP	8	15
RE0500000K0	4	45	SS2110920TP	2	37	SS7110910TP	10	41
RE0500000K0	26	13	SS3090610SP	32	10	SS7110910TP	14	25
RE0500711KP	14	8	SS4080610SP	24	16	SS7110910TP	24	18
RE0800000K0	28	10	SS4110515SP	2	35	SS7111410SP	14	11
RE0900000K0	16	65	SS4110815SP	2	17	SS7111810SP	20	8
RO092270200	14	45	SS4111215SP	2	2	SS7111810SP	38	22
RO092270200	26	14	SS4120615SP	38	18	SS7112420SP	16	86
SB120000200	6	53	SS5090610SP	2	21	SS7120710SP	16	80



## NUMERICAL INDEX OF PARTS

PART NO	PAGE	REF NO.	PART NO	PAGE	REF NO.
SS7120760SP	6	54	WP1702600S0	36	19
SS7120760SP	38	16	WS0510002KN	36	16
SS7150910TP	2	19	WS0610002KN	44	3
SS7151210SP	38	8	WS0610002KP	16	73
SS7151610SP	44	4			
SS7621040SP	2	7			
SS8090540SP	4	43			
SS8110422TP	20	40			
SS8150510TP	20	34			
SS8150710SP	10	9			
SS8150710TP	6	49			
SS8150822TP	4	30			
SS8150822TP	14	59			
SS8150822TP	16	59			
SS8151150TP	8	5			
SS8151150TP	14	14			
SS8151150TP	20	32			
SS8151550SP	6	60			
SS8660530TP	20	37			
SS8660610TP	10	8			
SS8660610TP	14	64			
SS8660610TP	16	64			
SS8660612TP	10	3			
SS8660670SP	20	36			
SS8660810TP	4	22			
SS8660810TP	20	39			
SS8661030SP	6	52			
SS9151440CP	14	4			
TA0370601M0	8	6			
TA0750404R0	10	10			
TA1050504R0	2	40			
TA1250406R0	2	3			
TA1250504R0	2	15			
WP0320501SC	30	12			
WP0371016SD	20	11			
WP0482086SD	10	34			
WP0501016SD	40	48			
WP0501046SC	10	18			
WP0502616SD	16	84			
WP0612056SD	16	72			
WP0621016SD	14	5			
WP0621016SD	44	2			
WP0641601SD	38	4			
WP0650876SD	16	93			
WP0850002SP	20	19			