

MODEL : FU-03

List No : 1249-01

# PARTS LIST

Published:09/10/2017

## CONTENTS

---

TURN AROUND MECHANISM CMPONENTS.....	1
HOW TO MAKE USE OF THIS PARTS LIST .....	5

TURN AROUND MECHANISM COMPONENTS

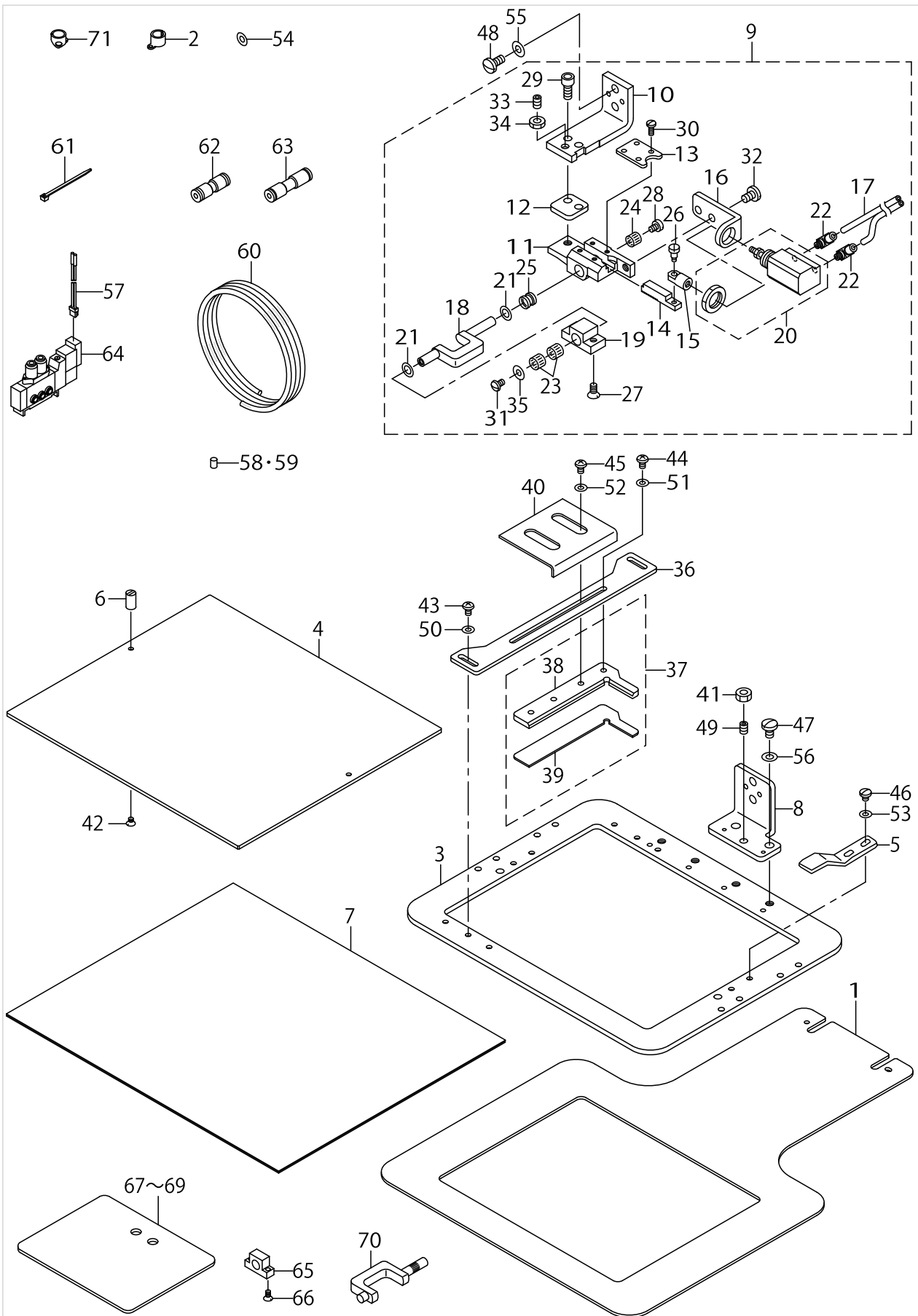

TURN AROUND MECHANISM CPMONENTS

No.	Parts No.	Parts name	Remarks	Level	Cons	Qty
1	GFU03003000	LOWER PLATE				1
2	B1406210000	THREAD GUIDE				1
3	B2553215A00	FRAME				1
4	B2557215A00	PLASTICS BLANK				2
5	B2558220000	PLASTIC BLANK PLATE				2
6	B2559220000	HINGE PIN				4
7	B2564215A00	SPONGE				1
8	B2604215AA0	PRESSER FOOT ASM., RIGHT				1
9	B43012150A0	INNER PRESSER FOOT ASM.				1
10	B4301215000	INNER PRESSER FOOT		*		1
11	B4302220000	BEARING		*		1
12	B4303220000	SPACER		*		1
13	B4304220000	SUPPORT RACK		*		1
14	B4305220000	TURN RACK		*		1
15	B4306220000	KNUCKLE		*		1
16	B4307220000	BRACKET		*		1
17	B4308215000	CYLINDER TUBE		*		1
18	B4309220000	CRANK SHAFT		*		1
19	B4320220000	SUPPORT BASE		*		1
20	B4327220000	CYLINDER		*		1
21	B4328220000	WASHER		*		2
22	PJ046052503	HOSE ELBOW		*		2
23	SB307000100	NEEDLE BEARING		*		2
24	SB307000100	NEEDLE BEARING		*		1
25	SB307000200	BEARING		*		1
26	SD0460703TP	HINGE SCREW D=4.6 H=7		*		1
27	SS1121010SP	SCREW		*		2
28	SS6110640SP	SCREW 11/64-40 L=6		*		1
29	SS6151412TP	SCREW 15/64-28 L=14		*		2
30	SS7090910TP	SCREW 9/64-40 L= 8.5		*		4
31	SS5110710SP	SCREW 11/64-40 L=7		*		1
32	SS7150940SP	SCREW 15/64-28 L=9		*		2
33	SS8150912TH	SCREW 15/64-28 L=9		*		1
34	NS6150310SP	NUT 15/64-28		*		1
35	B322877100B	BOBBIN WINDER SPACER		*		1
36	B4310215000	LABEL GUIDE A				1
37	B43112200A0	LABEL GUIDE B ASM.				1
38	B4311220000	LABEL GUIDE B		*		1
39	B4315220000	SEAT		*		1
40	B4312220000	LABEL GUIDE C				1
41	NS6150330SD	NUT 15/64-28				1
42	SS1090510SP	SCREW 9/64-40 L=5				4
43	SS4110715SP	SCREW 11/64-40 L=7				2
44	SS4110715SP	SCREW 11/64-40 L=7				2
45	SS4110715SP	SCREW 11/64-40 L=7				2
46	SS7110510SP	SCREW 11/64-40 L=5				4
47	SS7150910TP	SCREW 15/64-28 L=9				2

TURN AROUND MECHANISM COMPONENTS

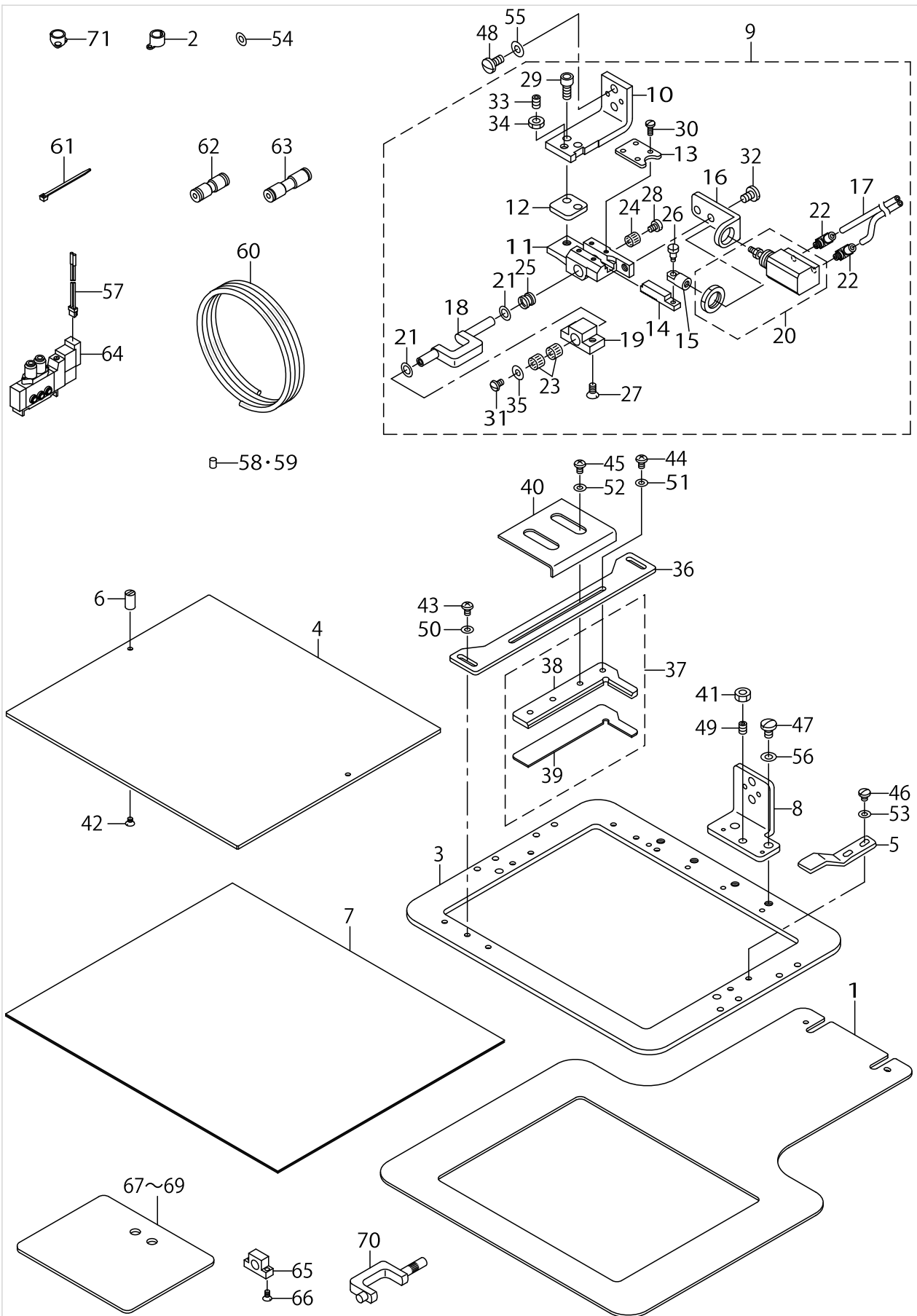

TURN AROUND MECHANISM CMPONENTS

No.	Parts No.	Parts name	Remarks	Level	Cons	Qty
48	SS7151210SP	SCREW 15/64-28 L=12				2
49	SS8150822TP	SCREW 15/64-28 L=8				1
50	WP0450000SD	WASHER 4.5X8X0.5				2
51	WP0450000SD	WASHER 4.5X8X0.5				2
52	WP0450000SD	WASHER 4.5X8X0.5				2
53	WP0450801SD	WASHER 4.5X10X0.8				4
54	WP0502616SD	WASHER				1
55	WP0651056SD	WASHER 6.5X11X1				2
56	WP0651056SD	WASHER 6.5X11X1				2
57	14204754	SOLENOID VALVE CONNECTOR ASM.				1
58	B471122000I	AIR TUBE LABEL J07				1
59	B471122000J	AIR TUBE LABEL J08				1
60	BT0400251EB	URETHANE HOSE, BLACK				2
61	HX002330000	CLIP				5
62	PJ303040002	STRAIGHT UNION				1
63	PJ303040004	QUICK COUPLING				1
64	PV150209000	5 PORT SOLENOID VALVE				1
65	B4316220000	SUPPORT BASE B	OPTIONAL PART			1
66	SS1090750SP	SCREW 9/64-40 L=7	OPTIONAL PART			2
67	B4317220000	LARGE BLANK (DIAMOND CUT)	OPTIONAL PART			1
68	B4318220000	MIDDLE BLANK (DIAMOND CUT)	OPTIONAL PART			1
69	B4319220000	SMALL BLANK (DIAMOND CUT)	OPTIONAL PART			1
70	B4326220000	CRANK SHAFT B	OPTIONAL PART			1
71	B1406215P00	THREAD GUIDE H	FOR PERFECT STITCH SPECIFICATIONS			1

## HOW TO MAKE USE OF THIS PARTS LIST

1.As to "#01" and "#02" refer to the "Note" given at the bottom of the respective pages.

2.Codes on the "Qty" column

- Each numeral indicates the number of parts required.
- "0.1" and "2.5" indicate the length (in meters) of the respective parts.

3.Parentheses mean that the corresponding part is a subpart that constructs an assembly part.

4.Dotted lines on the Figures indicate assembly parts.

1. リストページの# 0 1、# 0 2の印は、ページ下の"注記"の説明を参照下さい。
2. 数量欄の数字は、個数を表し、0. 1、2. 5等の数値は、長さ（単位メートル）を表します。
3. 数量欄の（ ）は、組部品を構成している子部品であることを意味します。
4. イラストページの-----枠は、組構成であることを意味します。

NUMERICAL INDEX OF PARTS

PART NO	PAGE	REF NO.	PART NO	PAGE	REF NO.
14204754	4	57	SB307000200	2	25
B1406210000	2	2	SD0460703TP	2	26
B1406215P00	4	71	SS1090510SP	2	42
B2553215A00	2	3	SS1090750SP	4	66
B2557215A00	2	4	SS1121010SP	2	27
B2558220000	2	5	SS4110715SP	2	45
B2559220000	2	6	SS5110710SP	2	31
B2564215A00	2	7	SS6110640SP	2	28
B2604215AA0	2	8	SS6151412TP	2	29
B322877100B	2	35	SS7090910TP	2	30
B4301215000	2	10	SS7110510SP	2	46
B43012150A0	2	9	SS7150910TP	2	47
B4302220000	2	11	SS7150940SP	2	32
B4303220000	2	12	SS7151210SP	4	48
B4304220000	2	13	SS8150822TP	4	49
B4305220000	2	14	SS8150912TH	2	33
B4306220000	2	15	WP0450000SD	4	52
B4307220000	2	16	WP0450801SD	4	53
B4308215000	2	17	WP0502616SD	4	54
B4309220000	2	18	WP0651056SD	4	56
B4310215000	2	36			
B4311220000	2	38			
B43112200A0	2	37			
B4312220000	2	40			
B4315220000	2	39			
B4316220000	4	65			
B4317220000	4	67~69			
B4318220000	4	67~69			
B4319220000	4	67~69			
B4320220000	2	19			
B4326220000	4	70			
B4327220000	2	20			
B4328220000	2	21			
B471122000I	4	58·59			
B471122000J	4	58·59			
BT0400251EB	4	60			
GFU03003000	2	1			
HX002330000	4	61			
NS6150310SP	2	34			
NS6150330SD	2	41			
PJ046052503	2	22			
PJ303040002	4	62			
PJ303040004	4	63			
PV150209000	4	64			
SB307000100	2	24			