

CONSEW *Since 1898* ®

CONSOLIDATED SEWING MACHINE CORP.

└ INDUSTRIAL SEWING & CUTTING EQUIPMENT

Model 106R

**INSTRUCTION MANUAL
&
PARTS BOOK**

Table of Contents

1. Introduction.....
2. Main specifications.....
3. Installation and preparation.....
Installation.....
1) Location of the machine.....
2) Installing drip pan.....
3) Mounting machine head.....
4) Mounting rock shaft bracket knee lifter.....
5) Installing the motor.....
6) Connecting the clutch lever to the pedal.....
7) Installing the bobbin winder.....
8) Installing the thread un-winder.....
Preparation.....
1) Cleaning the machine.....
2) Examination.....
3) Lubrication.....
4) Trial run.....
4. Operation.....
1) Selection of the thread.....
2) Coordinating between needle, thread and sewing material.....
3) Installing the needle.....
4) Winding the bobbin thread.....
5) Threading the needle thread and drawing the bobbin thread.....
6) Setting the bobbin.....
7) Installing the bobbin case.....
8) Setting stitch length and reverse sewing.....
9) Presser bar height position.....
10) Adjusting the pressure on the presser foot.....
5. Adjusting thread tension.....
1) Adjusting the thread take-up spring.....
2) Adjusting the thread guide.....
3) Adjusting the tension of needle thread and bobbin thread.....
6. Adjustments.....
1. Timing between needle and rotating hook.....
1) Adjusting position of the needle bar.....
2) Adjusting rotating hook timing with needle.....
3) Removing and installing the rotating hook.....
2. Adjusting the feed dog.....
1) Adjusting the height.....
2) Adjusting the position.....
3. Adjusting the tension release mechanism.....
7. Cleaning.....
1. Cleaning the feed dog.....
2. Cleaning the rotating hook.....
8. Trouble shooting.....

Parts catalogue

- 1. Arm and Bed.....
- 2. Needle arm and thread take-up.....
- 3. Arm shaft and vertical shaft.....
- 4. Rotating hook and shaft.....
- 5. Stitch length Regulating parts.....
- 6. Feed dog lift mechanism.....
- 7. Presser bar and drawing bar.....
- 8. Lubrication.....
- 9. Knee lifter.....
- 10. Bobbin winder.....
- 11. Thread un-winder.....
- 12. Accessories.....

Operating Instructions

1. Introduction

The Consew 106R sewing machine is a single needle, lockstitch designed for medium to heavy duty usage. It is engineered with a needle bearing, thread link take-up, spiral bevel gear transmission and a large rotating hook with a double thread capacity. It has all the advantages of a low torque, low noise, smooth and even feed when sewing a single layer of fabric or a lap seam. The Consew 106R produces, beautiful, even, flat stitches and is widely used in the manufacture of suitcases, leather goods, handbags, tarps, pillows, shoes and worker safety items.

2. Specifications

1) Max. Sewing speed:	2000 spm
2) Max. stitch length:	9 mm
3) Presser foot lift:	6.5 mm -13mm w/knee lifter
4) Max. thickness of material to be sewn:	up to 8 layers of leather, with a thickness of 8 mm each
5) Needle:	DPx5, #18~22
6) Hook:	Large rotating hook with double thread capacity
7) Motor:	½ HP, 1PH, 110V Clutch Motor

3. Installation and preparation

1) Placement of the machine

To ensure smooth vibration free operation, the machine should be placed on an even and firm floor. Placing the machine stand on a rubberized mat is recommended to further reduce the noise and vibration.

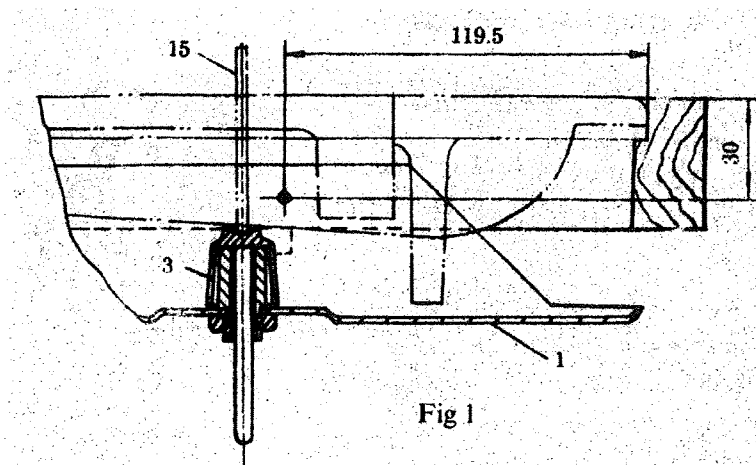

2) Installing drip pan (Fig. 1). Fix drip pan (1) into the table cutout, aligning knee lifting rod (3) with knee lifter connecting rod (15) of machine head, so they touch, also make sure dimensions are at 30 and 119.5mm from nail hole to the table, (as depicted in Fig. 1) then drive nails (2) into both sides of the cutout to secure the drip pan. (See figure on 9 of parts book).

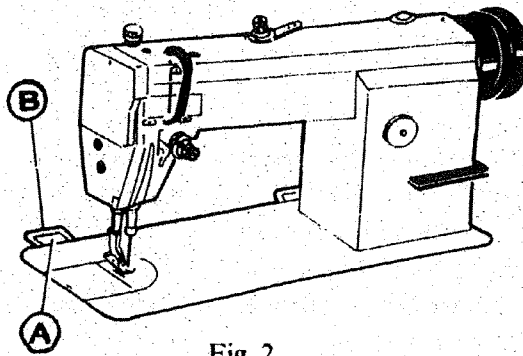

Fig. 2

3) Mounting machine head (Fig.2)

Hinge A on machine head should align with hinge socket B on the table, move the machine head carefully until it is firmly in place on the frame of table cutout.

4) Mounting rock shaft bracket of knee lifter (Fig.3, also see figure in chapter 9)

1. Adjust rock shaft knee plate (18) so it is comfortable for the machine operator to use.

2. Adjust the position of knee lifter assembly following Fig. 3, then fasten the rock shaft bracket (7) with wood screws (6).

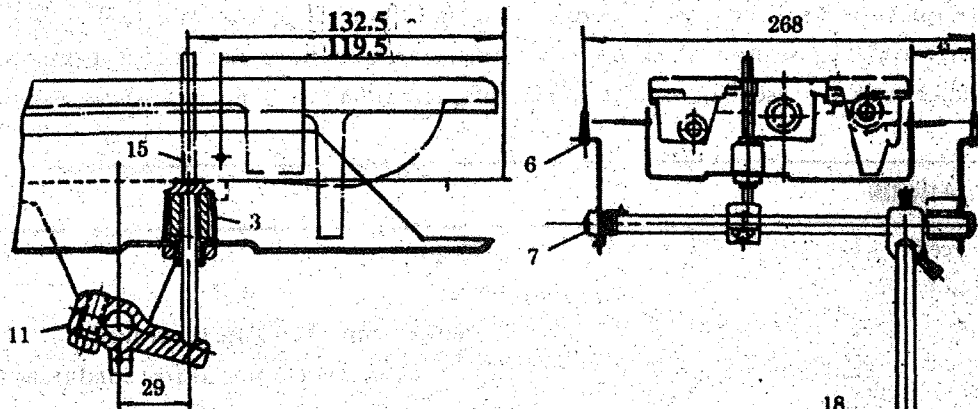

Fig. 3

5) Installing the motor (Fig. 4)

Align machine balance wheel belt groove A with motor pulley belt groove B by moving the motor C leftward or rightward. Be sure the belt is not touch with table.

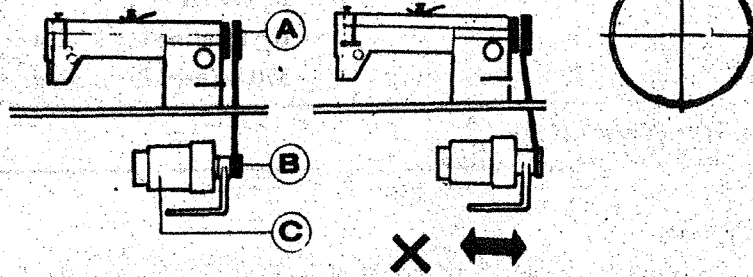

Fig. 4

6) Connecting the clutch lever to the pedal (Fig. 5)

1. The optimum tilt angle of pedal (A) to the floor is approx. 15 degree.
2. Adjust the clutch on the motor so that clutch lever C and draw bar B run in line.
3. The machine balance wheel should rotate counterclockwise for normal sewing (G). The motor rotates in the same direction. The rotation can be reversed by simply turning the plug on the motor over.
4. Adjust the tension of the 0-belt (F) by moving the motor vertically up or down. The proper tension of the V-b-belt is relatively slack. When the belt is pushed at the belt span the give should equal about $\frac{1}{2}$ to $\frac{5}{8}$ of an inch.

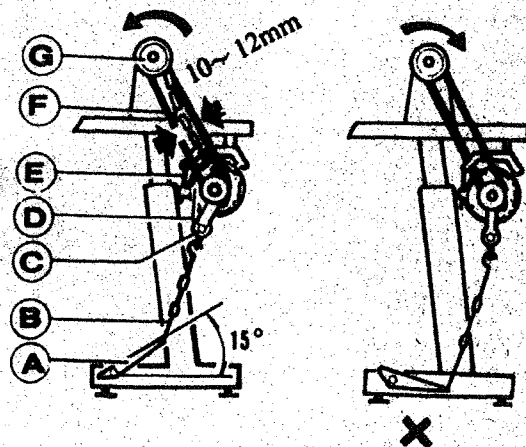

Fig. 5

7) Installing the bobbin winder (Fig. 6)

Align pulley (B) on bobbin winder with the outside of belt C. A uniform amount of clearance must be constant so the pulley remains in contact with the belt even after it stops running. Using the thumb latch lever (A) to push the bobbin winder wheel in place drives the bobbin winder while the machine is running. Make sure the bobbin winder is aligned with the slit (E) in the sewing machine table before running the machine. The bobbin winder is fastened to the table with two wood screws (D).

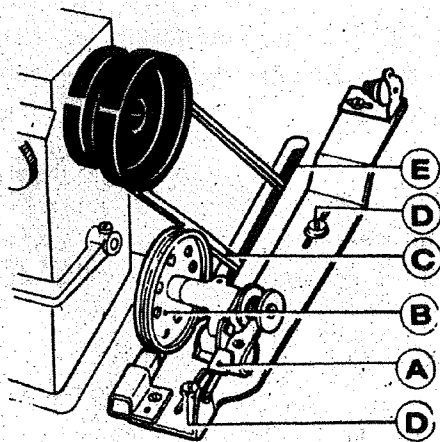

Fig. 6

8) Installing the spool stand (Fig.7)

Install spool stand at the right rear corner of the table. Make sure that the stand doesn't obstruct the machine. Secure the stand in place by tightening wood screws (C).

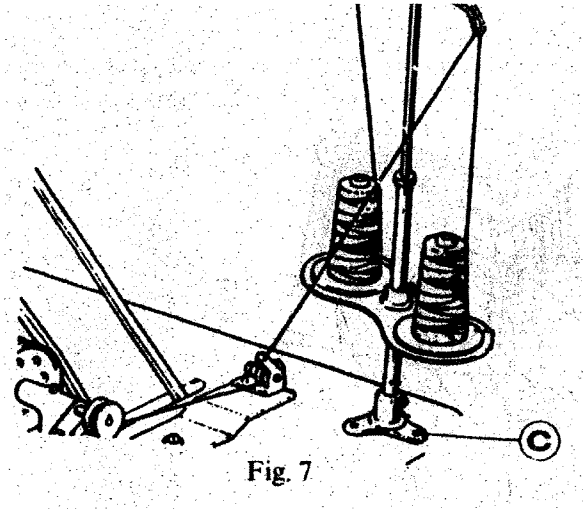

Fig. 7

2. Preparation

1) Cleaning the machine

Before delivery, the machine parts are coated with rust preventive grease, which may have hardened during storage and/or shipment. This grease must be removed with a clean cloth and a solvent.

2) Examination

Though every machine is sewn off and subjected to a detailed inspection before delivery, the machine parts may have loosened or come undone during shipment. A thorough examination must be performed after cleaning the machine. Turn the balance wheel to see if there is an obstruction, resistance or any abnormal noise. If any of these situations are present, adjustments must be made before running the machine.

3) Lubrication

Before running the machine, clean it with a soft cloth, then fully lubricate at the points indicated by the arrows shown in Fig 8 and Fig 9. If the machine is continuously operated, the operator should lubricate it no less than twice a day. Be sure to use #8 Sewing Machine Oil or #7 Machinery oil.

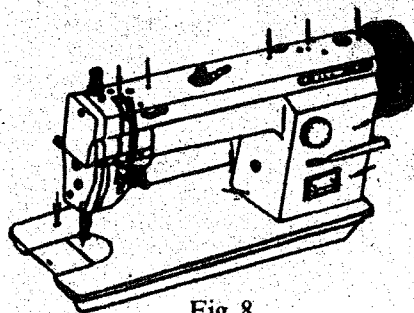

Fig. 8

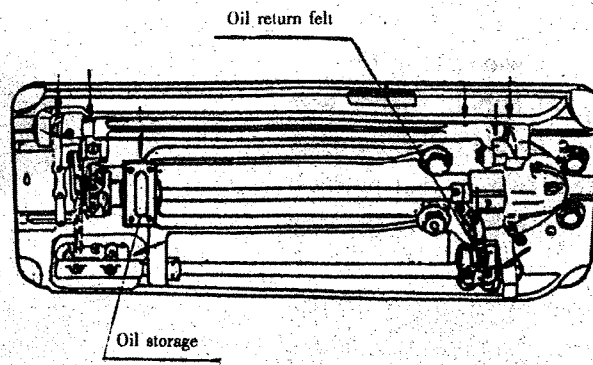

Fig. 9

To make sure the pump in the oil pan is secure; an oil-return felt should be installed. (See Fig9) The oil pan is not filled with sewing machine oil when it leaves the factory. Fill oil pan before use. Apply oil from point A to F & G through H, I, J (See Fig 10). Apply oil from point B to C, D, & E (See Fig11) through oil distribution.

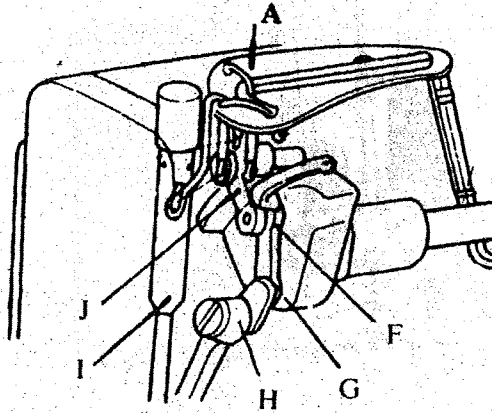

Fig 10

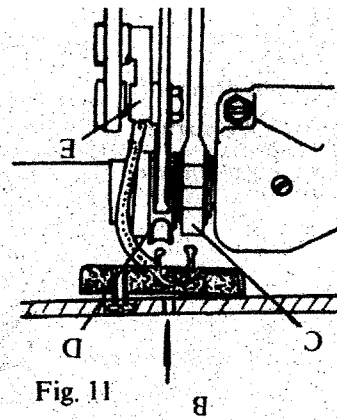

Fig. 11

The bevel gear cases in Fig. 12 and Fig. 13 are packed with lubricant and it should be re-applied periodically as it will dissipate gradually after a long period of use. When you replenish undo the screw plugs L & K first then apply with fresh lubricant through screw hole into gear cases then re-insert screw plugs. Should the lubricant in the bevel gear cases be too dirty or hardened, it must be changed.

4) Trial run

A trial is imperative with a new machine or if the machine has not been used for an extended period of time. Before you begin, lift the presser foot to make sure that the balance wheel is turning in the right direction. Begin by running the machine at a low speed. If the machine is running smoothly increase the speed gradually until you reach 2000 spm. Run at this speed for a few minutes. The machine is now ready to use.

4. Operation

1. Thread selection

Needle thread should be left-twist thread. For bobbin thread, either left or right twist thread is may be used. To identify the twist direction of the thread, hold the thread as shown in Fig.13; twist the thread with the right hand in the direction of the arrow. If the thread tightens, the thread is left-twist thread otherwise the thread is right—twist.

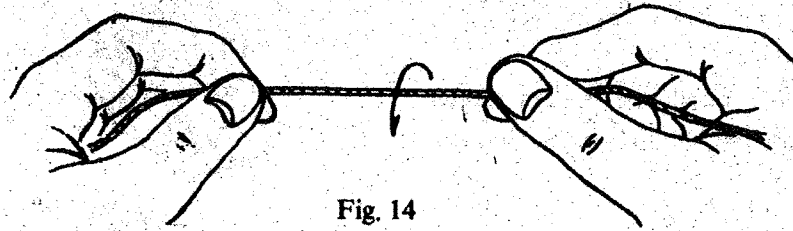

Fig. 14

2. Coordinating needle, thread and fabric

Needle: DPX5 or 135X7

Needle size should be based on the thread and fabric to be sewn.

The following table is for reference.

Needle Size	Kind and number of thread	Material to be sewn
#18	Cotton thread #30-#40	Clothes, canvas heavy wool
#19	Linen thread #60-#80	leather cloth, shoes, cap, hand bag
#21	Polyester thread #20-#40	Heavy fabric,
#22	linen thread #40-#60	leather goods,
	glazed thread #40-#60	sofa, suitcase, bag,
	mercerized thread #21-#60	tarpaulin, cushion

3. Installing the needle (Fig 15)

Turn the balance wheel to lift the needle bar to the highest position, loosen needle set screw (1), insert the needle shank up to the bottom of needle socket (see Fig 15) then tighten needle set screw 1.

Fig. 15(b): incorrect insertion, not high enough

Fig. 15(c): needle groove is facing the wrong direction.

Fig. 15(a): inserted correctly

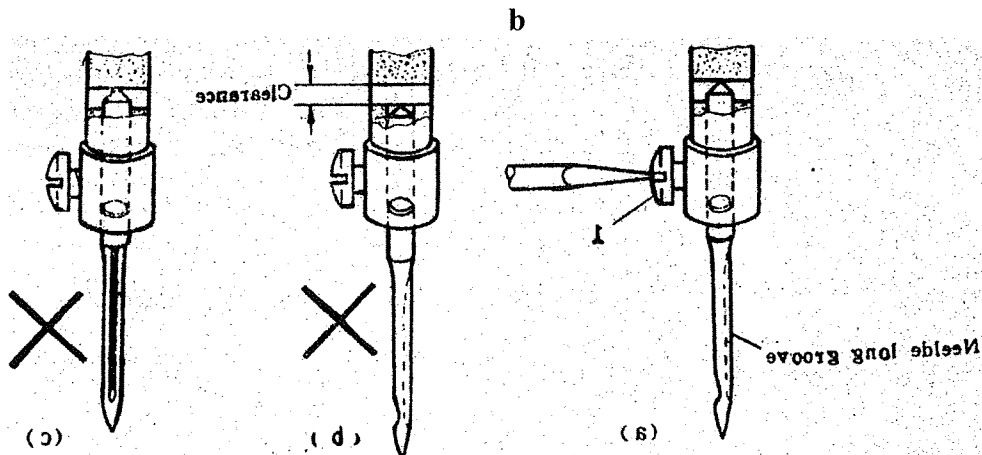

Fig. 15

4. Winding the Bobbin thread

1) Directions (Fig. 16)

Install bobbin (A) onto bobbin winder spindle (B). Pass thread (C) from spool through the eye (1) on tension bracket (E) pass it between tension discs (2) and then wind the end of the thread a few turns on the bobbin. Push stop latch thumb lever (D) down to lock the bobbin. The winder pulley (F) is now engaged by belt (G). Start the machine. Please note when thread is wound without sewing be sure to keep the presser foot lifted. When the thread is fully wound, the bobbin winder stop latch automatically releases the bobbin winder and stops it.

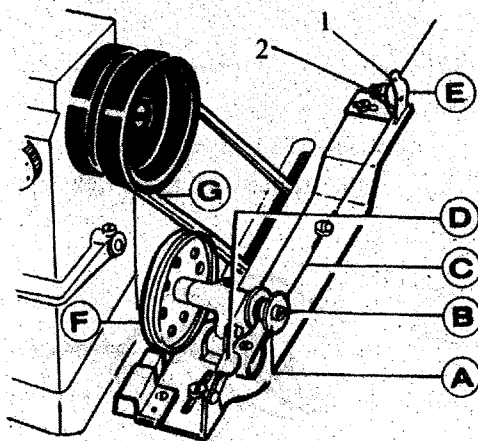

Fig. 16

2) Winding adjustment (Fig. 17)

The bobbin thread should be neat, tight and uniform. If not, adjust the tension by turning tension stud thumb nut (A) on bobbin winder tension bracket. When the thread layer does not present an even, cylindrical shape, loosen tension bracket screw (B) and move tension bracket (C) left or right. If thread is wound as shown in Fig. 17b, move the tension bracket right, if thread is wound as shown in Fig. 17c, move the tension bracket left. After adjusting the tension bracket to your needs, tighten screw (B).

Note: nylon or polyester thread should be wound with a light tension; otherwise bobbin (D) might break. Do not over fill the bobbin, for optimum performance the capacity of the bobbin should be at about 80%.

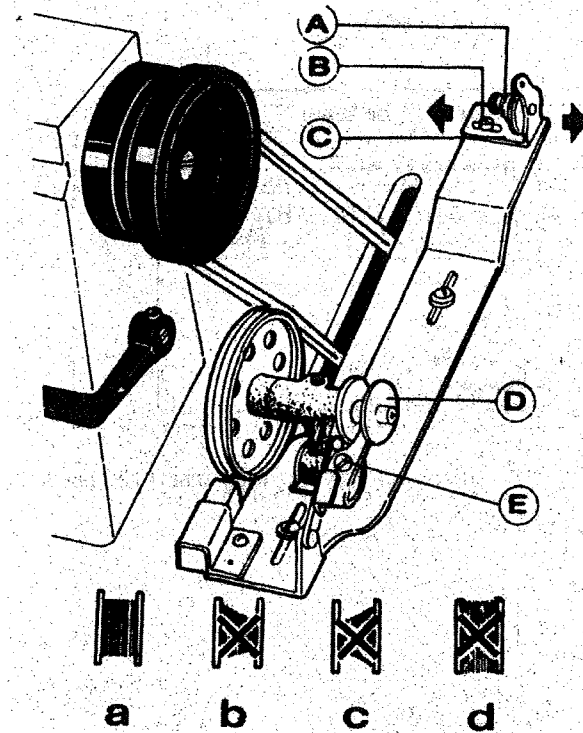

Fig. 17

5. Threading the needle and drawing the bobbin thread

To thread the needle, raise needle bar to its highest position, pull thread from the spool and pass it in the numerical order depicted in Fig. 18. (1) Pull thread from spool, pass it through the guide plate (1) at the top of the machine, then thread it between the thread tension discs, and thru the left hole of guide plate(1). Continue through three-eyed thread guide (2). (3) Pass thread between thread tension discs (3). Pass upward thru thread take-up spring (4) and thread guide (5) and (6) then pass it through the thread take-up lever (7) from right to left. (5) Pass it down thru thread guide (8), (9) of needle bar bushing (lower) and needle bar thread guide (10). Then pass it from the left through the needle eye (11), once threaded pull out approximately 3 inches of thread. To draw up the bobbin thread, hold the end of the thread, turn the balance wheel to lower the needle bar and then continue until it reaches its highest position. Pull the needle thread and the bobbin thread will follow. Pull the ends of both threads towards you and under the presser foot.

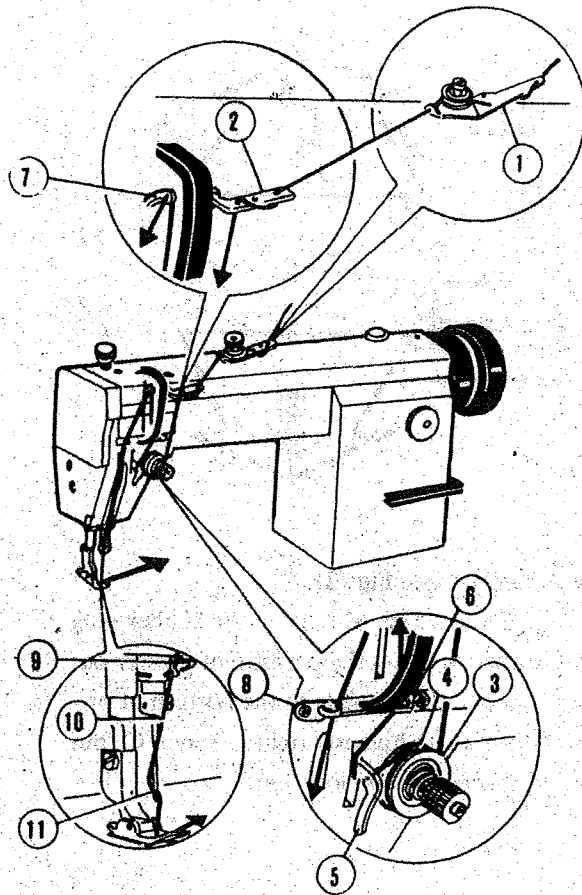

Fig. 18

6. Inserting the bobbin (Fig.19)

1) Put the bobbin B into the bobbin case A.

2) Pass the thread E thru slit C to lead it underneath

the bobbin case to the tension spring D and out at the notch of the spring, pull the thread out about 2".

Note: Make sure that the bobbin rotates clockwise when the thread E is pulled. If not, turn to another side of the bobbin B and try again.

7. Installing the bobbin case (Fig. 20)

Lift the needle bar to its highest position and open the bed slide. Lift the bobbin case latch lever A and holding it, securely install the bobbin case into the rotating hook B. Note that the bobbin case latch is engaged in the positioning groove of rotating hook spindle. When removing the bobbin case from the rotating hook, lift the bobbin case latch lever A completely and holding it by the fingertips to prevent the bobbin from dropping out of the bobbin case, then gently remove the bobbin case.

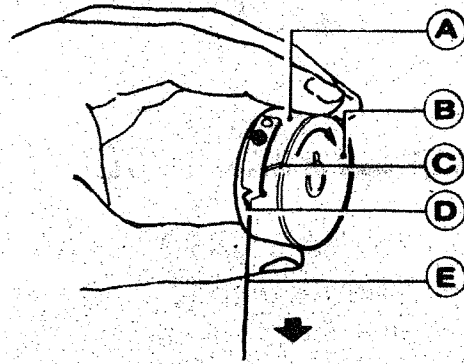

Fig. 19

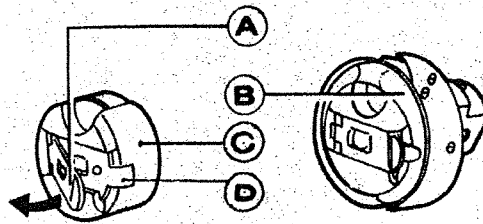

Fig. 20

8. Setting stitch length and reverse sewing (Fig. 21)

Stitch length can be set by turning stitch length regulating dial (1). The stitch length increases when you turn stitch length regulating dial (1) counter clockwise, and the stitch length decreases when you turn the dial (1) clockwise. Sewing reverses when feed reverse lever (2) is depressed, and forward sewing resumes automatically when the feed reverse lever is depressed once more (2).

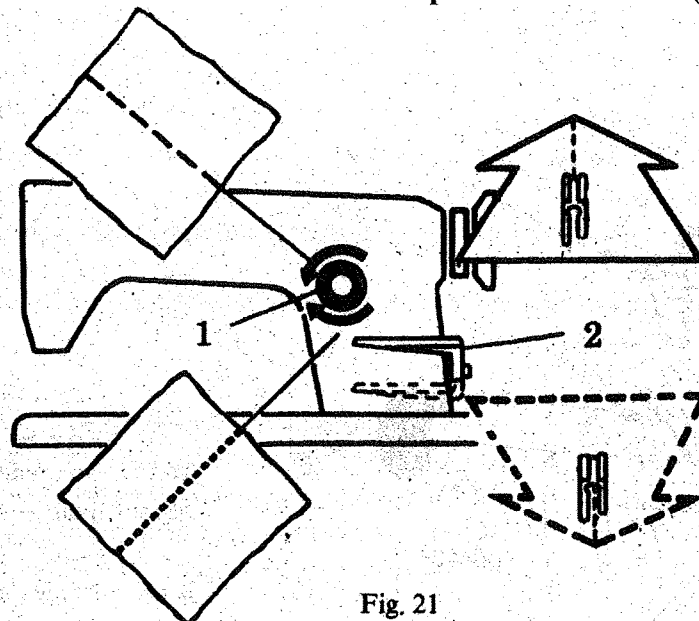

Fig. 21

9. Presser bar height positioning (see Fig 22)

Loosen lock nut E and screw A, remove the rubber plug on face plate B, loosen screw C, set the position of presser bar (6.5mm from the surface of throat plate to the bottom of presser foot as presser foot at its highest) tighten screw put on rubber plug, tighten screw A and lock nut B.

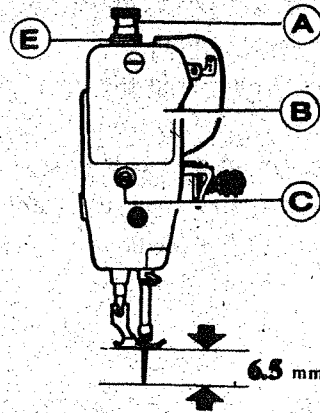
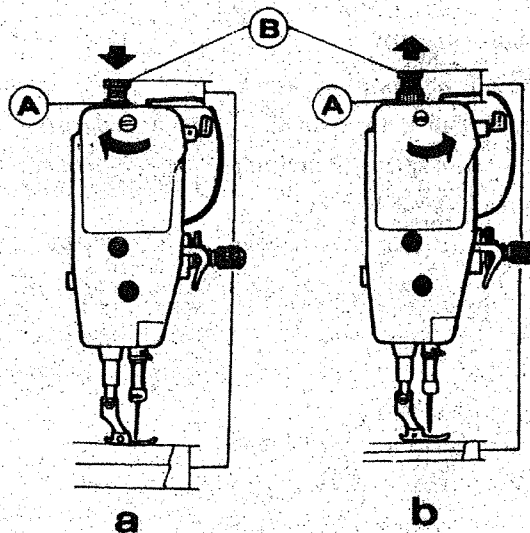

Fig 22

10. Adjusting the pressure of presser foot (Fig. 23)

Pressure on presser foot is to be adjusted in accordance with material to be sewn.

Loosen lock nut A first, then turn pressure regulating thumb screw as shown in Fig.23 to increase the pressure while turn the pressure regulating thumb screw in direction of arrow B to decrease the pressure on presser foot, then tighten lock nut A. The proper pressure should be that the material can be pushed normally.



5. Adjusting thread tension

In principle the thread tension should be adjusted in accordance with fabric and thread being used as well as other factors. In practice, the thread tension is adjusted according to the stitches that result. The needle thread tension should be adjusted in relation to the bobbin thread tension. To adjust the bobbin thread tension, turn bobbin case tension spring screw A (see Fig. 24) clockwise to increase the tension, or turn the screw counter-clockwise to decrease the tension.

It is common practice to check the bobbin thread tension as shown in Fig. 25. In case of coated thread hold the end of the thread and move bobbin case up and down, if the thread unravels slowly, the tension level is fine.

The needle thread tension can be adjusted by changing:

- (1) tension of the thread take-up spring,
- (2) swinging range of the thread take-up spring,
- (3) tension of thread tension spring
- (4) the position of thread guide and thread tension discs. Instructions on these steps follow.

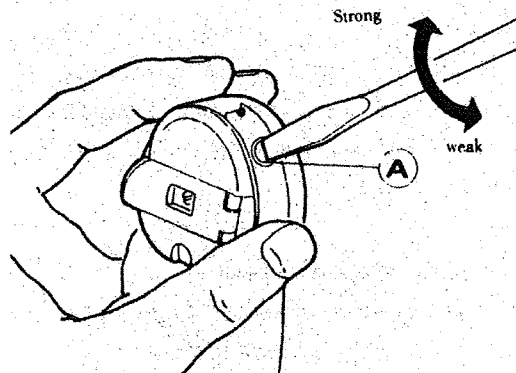

Fig. 24

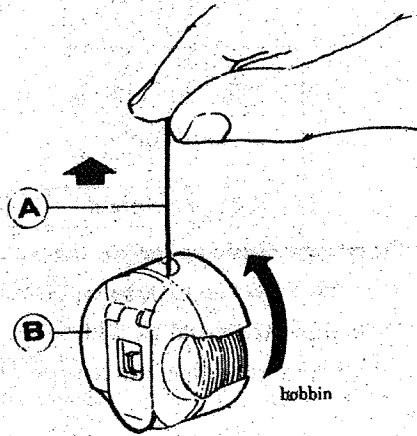

Fig. 25

1. Adjusting the thread take-up spring

The normal tension of the thread take-up spring is approx. 25-35g. The normal swing range of the thread take-up spring is 5-8mm. For sewing light weight materials (with a short stitch length), lessen the spring tension and widen the range of the spring. For sewing heavier weight materials, strengthen the spring tension and shorten the range of the spring.

(1) Adjusting the thread take-up spring tension (Fig. 26)

Loosen tension stud set screw A, turn tension stud B clockwise to increase the spring tension, or turn the tension stud counter-clockwise to decrease the spring tension. After the adjustment, be sure to tighten tension stud set screw A.

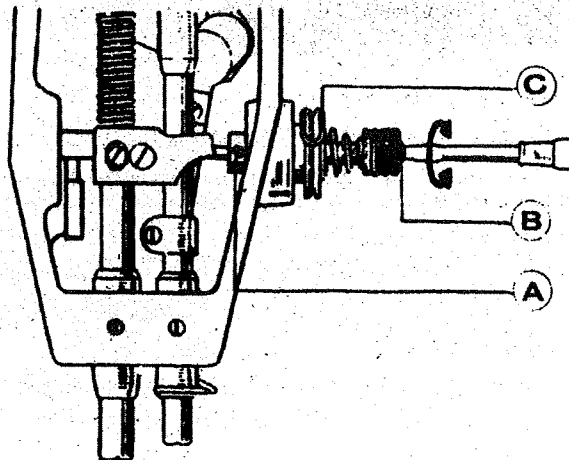

Fig. 26

The thread take-up spring tension is about 30g. To attain this, loosen set screw A first, then turn tension stud B counter clockwise to release the tension of thread take-up spring C to zero. Turn tension stud B counter-clockwise until spring C just comes into contact with the stopper on thread take-up spring regulator, then turn tension stud B clockwise by another 1 /2 turn. After adjustment, tighten tension stud set screw A.

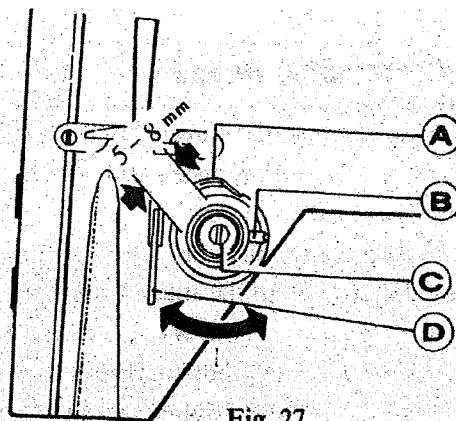

Fig. 27

(2) Adjusting the swing range of thread take-up spring (Fig. 27).

Loosen set screw B, turn tension complete C clockwise to increase the swing range or turn it counter-clockwise to decrease the swing range. Before delivery, thread take-up spring is properly adjusted. Re-adjustment is needed only in the case of sewing special materials or with special thread.

2. Adjusting the thread guide

The position of the thread guide affects the sewing quality and must be adjusted according to the materials being sewn and sewing conditions. The normal relationship between the position of the thread guide and the materials to be sewn is illustrated in the following table.

Thread guide
Position

Material weight

	1	2	3
	Left	Center	Right
	Heavy	Medium	Light

3. Adjusting the tension of needle thread and bobbin thread

Fig. 28 shows the various types of stitch patterns. Normal stitches should appear as shown in Fig. 28(a). When stitches are puckered, loose, or the thread breaks, the tension of needle and bobbin thread must be adjusted accordingly.

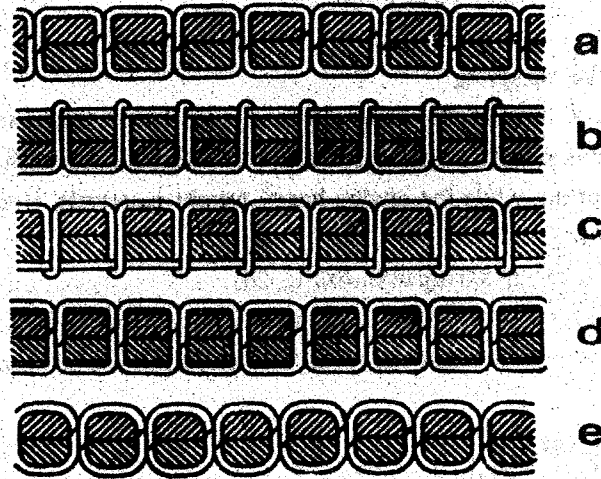

- 1) If the needle thread tension is too high or bobbin thread tension is too low, turn the tension regulating thumb nut counterclockwise to decrease the needle thread tension or tighten the bobbin case tension regulating screw to increase the bobbin thread tension (see Fig. 29).
- 2) If the needle thread tension is too low or bobbin thread is too high, turn the tension regulating thumb nut clockwise to increase the needle thread tension or turn the bobbin case tension regulating screw counterclockwise to decrease the bobbin thread tension (see Fig. 30).
- 3) If the stitches appear as shown in Fig. 28(d), (e), adjustments can be made by following the above steps.

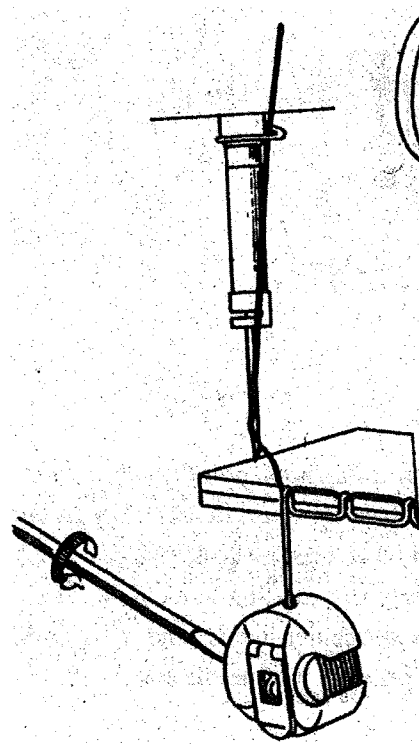

Fig. 29

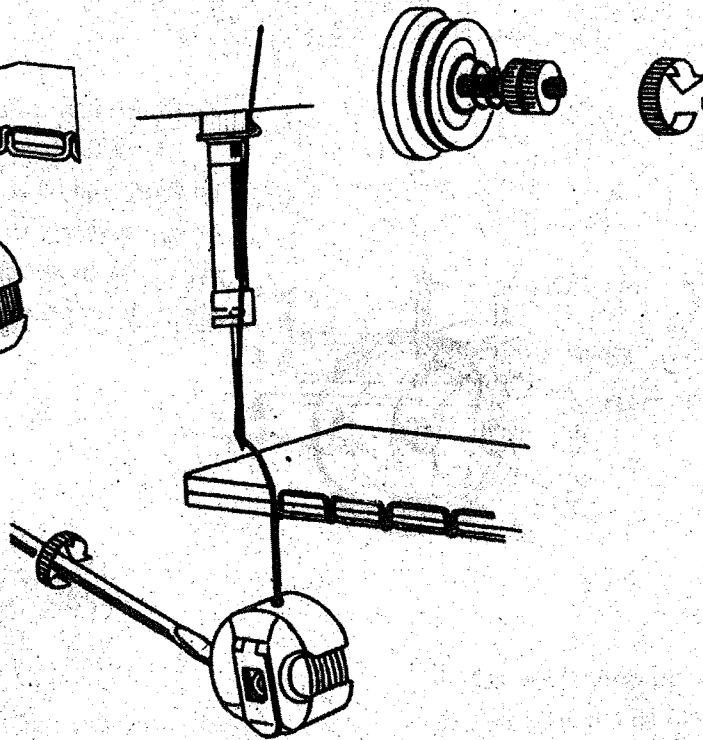

Fig. 30

6. Machine Adjustment

Timing between needle and rotating hook motion

1) Adjusting the needle bar position (Fig. 31)

Turn the balance wheel to position the needle bar, C at its lowest position. Remove the rubber plug from the face plate, A. Loosen needle bar C connecting stud clamping screw B. Move needle bar C vertically to bring the center of needle eye, D match up with the inside surface of rotating hook E. Then tighten clamping screw B and replace rubber plug.

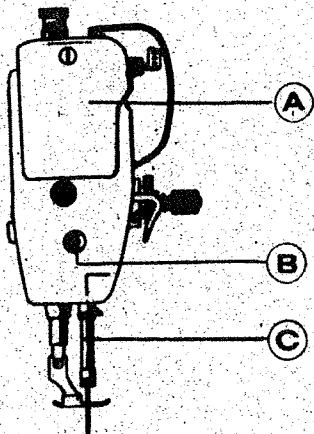

Fig. 31

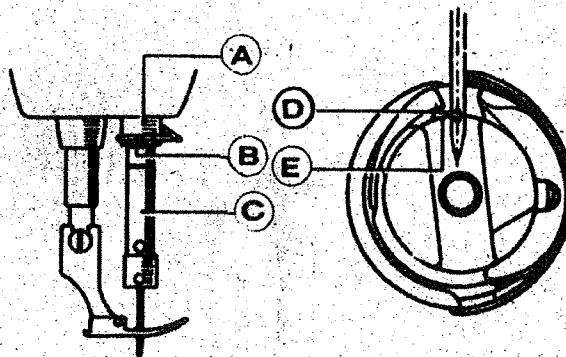

Fig. 32

2) Adjusting rotating hook point timing with needle (fig. 33)

Turn the balance wheel to position the needle bar at its lowest position, and when the needle bar is lifted again at 2.5 mm from its lowest position, the rotating hook point D should coincide with needle center line C, and hook point D should be 1.2mm above the upper edge E of needle eye.

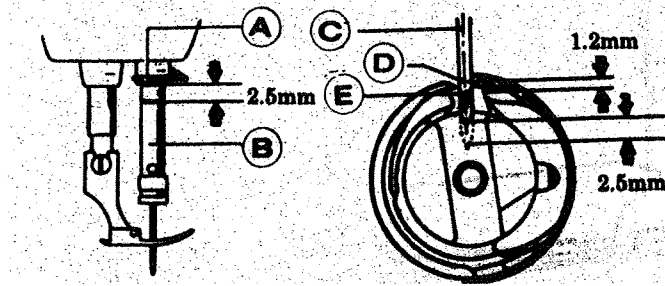

Fig. 33

When adjusting the rotating hook point timing also note that the clearance between the notched bottom of needle D and hook point C must be constant at approximately 0.05mm (see Fig. 34).

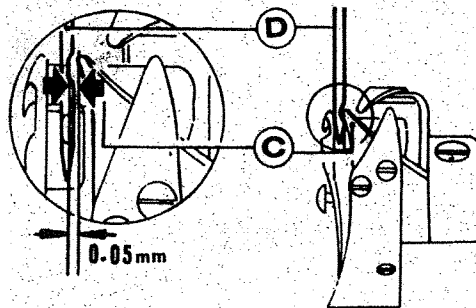

Fig. 34

3) Removing and installing the rotating hook (Fig. 35)

Lift the needle bar to its highest position. Remove the throat plate and take out the needle and the bobbin case. Loosen rotating hook bobbin case holder position bracket screw C and take down position bracket A. Loosen the two set screws D on rotating hook. At this point, the hook will turn freely on its shaft, and it can be kept from colliding with the feed dog support since the feed dog support is at its highest. Remove the rotating hook slowly. To install the rotating hook follow the above sequence in reverse.

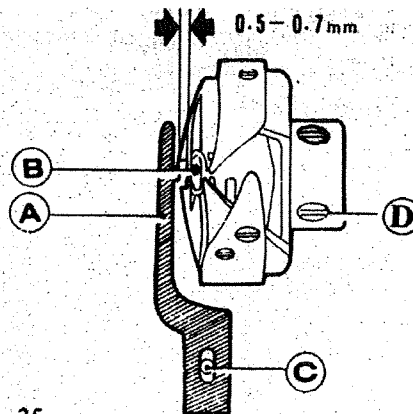
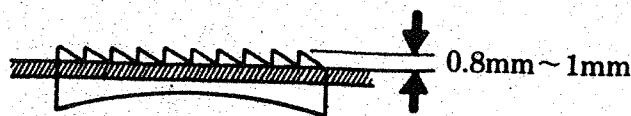

Fig. 35

2. Adjusting the feed dog

1) Adjusting the height of the feed dog

Turn balance wheel to raise the feed dog to its highest position, at that position, the height of feed dog teeth should be 0.8-1mm above the throat plate surface. If the height of the feed dog teeth is 1mm above the throat plate surfaces it is the ideal height for sewing heavy material.



When adjusting, loosen feed lifting rock shaft crank clamping screw A (Fig. 36) slightly, then turn feed lifting rock shaft crank B till the proper height of the feed dog teeth is achieved, after adjustment, tighten

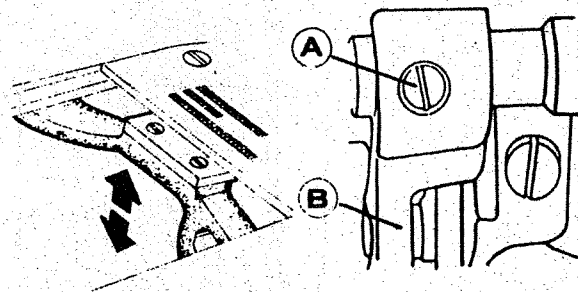

clamping screw A.

Fig. 36

2) Adjusting the position of feed dog (Fig. 37) The standard position of feed dog A is that the clearance from the throat plate slit end to the front end of the fully advanced feed dog is 1.5 mm.

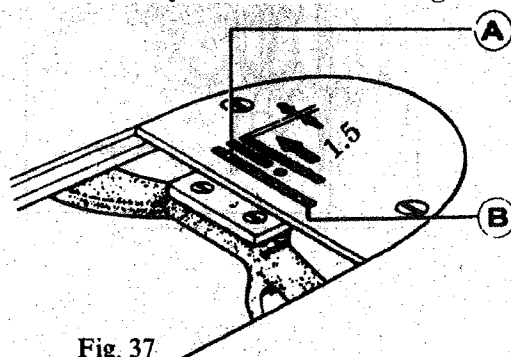

Fig. 37

2) Max the feed dog to the position where the feed dog fully advances. Loosen two feed rock shaft crank clamping screws. Move feed dog support to adjust the clearance between the feed dog and throat plate. After adjustment, tighten clamping screw.

3 Adjusting the tension release mechanism (Fig. 38)

The tension discs should be pushed apart to open when the presser foot is lifted. But the open timing of the tension discs can be adjusted. Remove the rubber plug at the rear of arm and loosen screw A of the knee lifting lever (left). Then the tension releasing cam can be moved left or right, open later when the cam is moved right, open earlier when the cam is moved left.

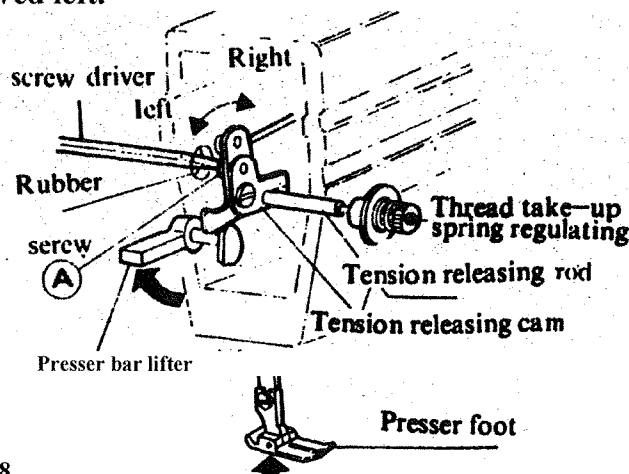

Fig. 38

7. Cleaning

1) Cleaning the feed dog (Fig. 39)

Remove the throat plate and clean off all the dust and lint on the feed dog with a brush.

2) Cleaning the rotating hook (Fig. 40)

Brush the hook and wipe the bobbin case with a soft cloth.

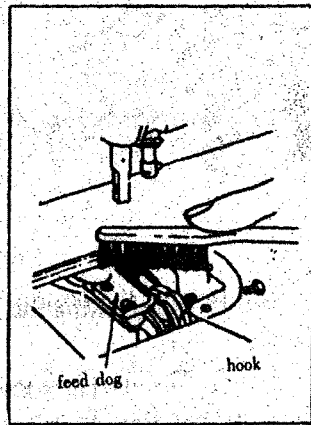

Fig. 39

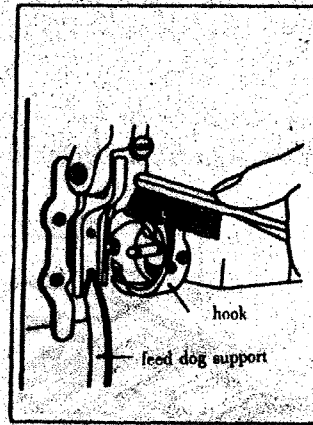

Fig. 40

8. Trouble shooting

Trouble	Possible causes	Remedy
Needle breaking	<ol style="list-style-type: none"> 1. Needle is too thin or bent. 2. Needle is set incorrectly. 3. Operator pushes or pulls the material. 4. The weight of the material being sewn is too heavy. 	<p>Change the needle. Refer to Fig. 15 Do not push or pull the fabric. Do not exceed the technical Specs of the machine</p>
Stitches skip	<ol style="list-style-type: none"> 1. Needle is bent or the needle number is not correct for the weight of the fabric. 2. Needle set incorrectly. 	<p>Change the needle. Refer to Fig. 15</p>
Needle thread Breaking	<ol style="list-style-type: none"> 1. Needle threaded incorrectly. 2. Tension too high. 3. Poor quality thread 4. Needle too thin or too rough. 	<p>Refer to Fig. 18 Refer to Fig. 29 Change the thread Change the needle</p>
Bobbin thread breaking	<ol style="list-style-type: none"> 1. The bobbin thread tension is too high 2. Thread on bobbin is loose and uneven. 3. Needle hole on throat plate is rough or worn. 	<p>Lessen the bobbin thread tension Re-wind the bobbin Change throat plate or polish needle hole with emery cloth</p>
Loose stitches	<ol style="list-style-type: none"> 1. Incorrect tension level on thread and bobbin 2. Tension too low on thread tension spring 	<p>Re-adjust tensions Adjust the tension on thread take-up spring-Fig. 26</p>
Puckering	<ol style="list-style-type: none"> 1. The weight of the fabric is too light, the stitch length too long 2. The tension on the needle and bobbin is too high 	<p>Adjust accordingly Adjust tension regulating thumb nut, thread take-up spring and bobbin case tension spring screw.</p>
	<ol style="list-style-type: none"> 3. Pressure on presser foot too high 	<p>Loosen pressure regulating thumb screw.</p>

Parts Catalogue

1.

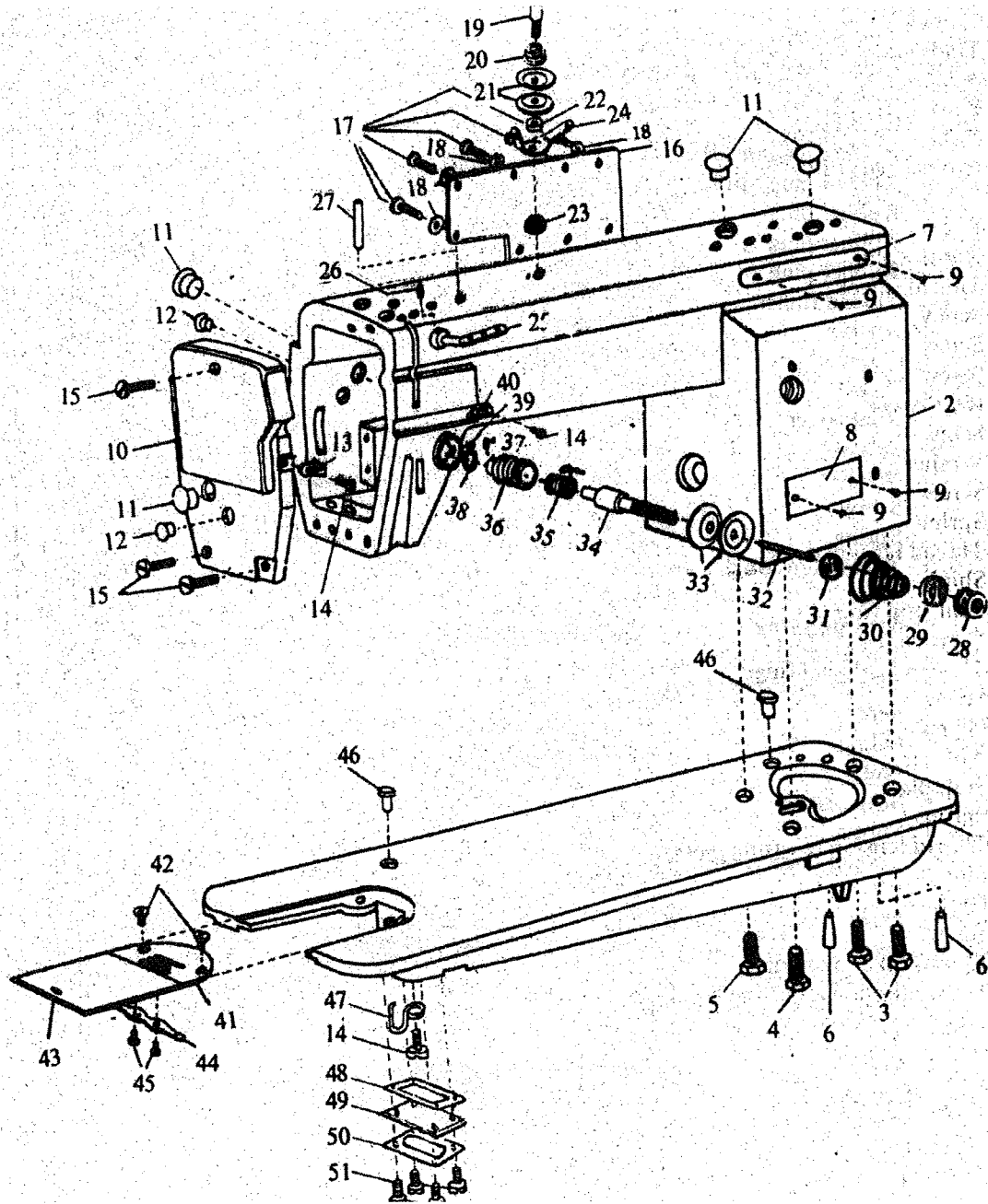

1. Arm and Bed

Item	Description	# of Pieces
1.	Machine Bed	1
2.	Machine Arm	1
3.	Screw	2
4.	Screw	1
5.	Screw	1
6.	Pin	2
7.	Name plate	1
8.	Trade mark	1
9.	Nail	4
10.	Face plate	1
11.	Rubber plug (M9)	1
	Rubber plug (N9)	1
12.	Rubber plug	2
	Rubber plug	1
	Rubber plug	1
13.	Thread Finger	1
14.	Screw	1
	Screw	1
15.	Screw	3
16.	Rear cover	1
17.	Screw	6
18.	Washer	6
19.	Screw	1
20.	Spring	1
21.	Thread tension discs	2
22.	Shim	1
23.	Split stop ring	1
24.	Thread guide plate	1
25.	three-eye thread finger	1
26.	Screw	1
27.	Oil pipe	1
28.	Nut	1
29.	Stop plate	1
30.	Spring	1
31.	Thread tension releasing plate	1
32.	Pin	1
33.	Discs	2
34.	Screw	1
35.	Thread take—up spring	1
36.	Thread tension adjusting bracket	1
37.	Screw	1
38.	0-type ring	1
39.	Set screw	1
40.	Thread finger	1
41.	Throat plate	1
42.	Screw	2
43.	Slide plate	1
44.	Spring	1
45.	Screw	2
46.	Oil plug	2
47.	Position finger for oil wick	1
48.	Seal ring	1
49.	Cover	1
50.	Press plate	1
51.	Screw	4

2.

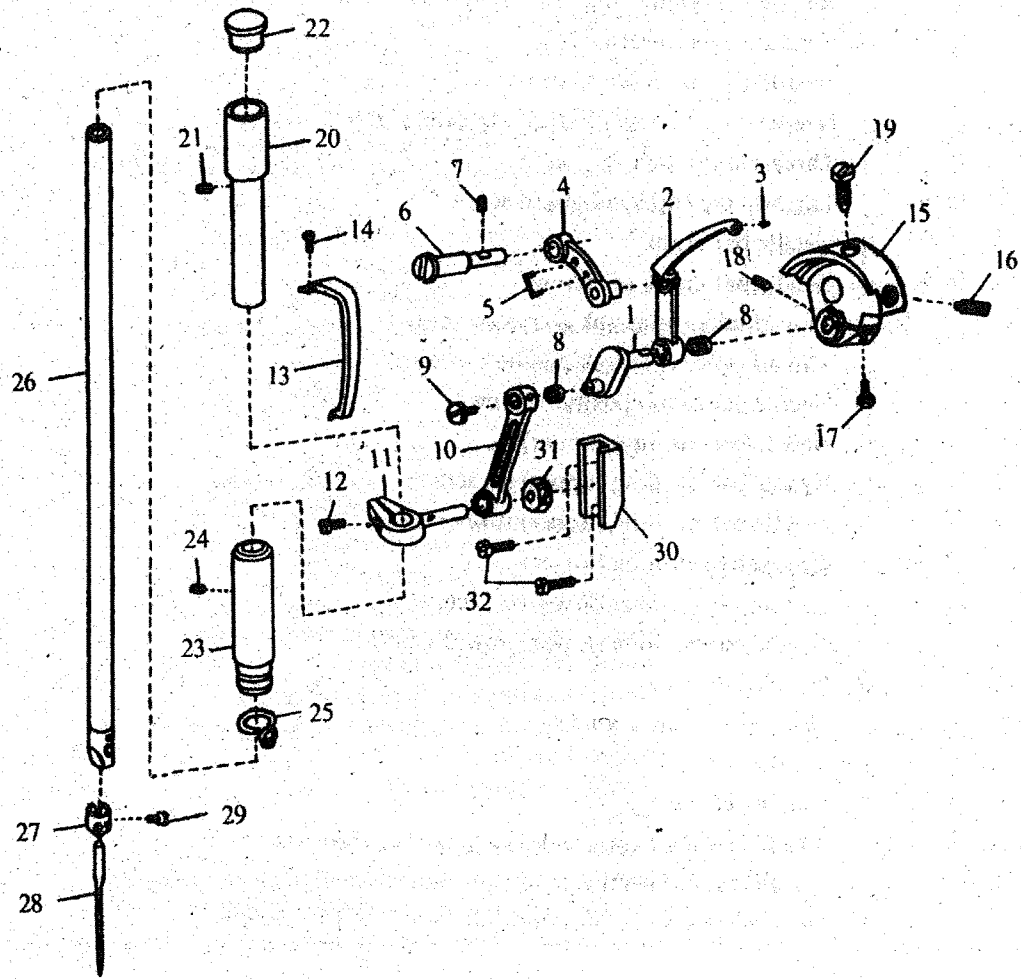

2. Needle Bar and Thread Take-up

Item	Description	#of Pieces
1.	Thread take-up crank	1
2.	Thread take-up lever	1
3.	Thread take-up lever eyelet bushing	1
4.	Thread take-up lever link	1
5.	Thread take-up lever link oil wick	1
6.	Thread take-up lever link hinge pin	1
7.	Thread take-up lever link hinge pin set screw	1
8.	Needle bearing	2
9.	Needle bar connecting link cap screw	1
10.	Needle bar connecting link	1
11.	Needle bar connecting stud	1
12.	Needle bar connecting stud clamping screw	1
13.	Thread take-up lever guard	1
14.	Thread take-up lever guard screw	1
15.	Needle bar crank	1
16.	Needle bar crank set screw	1
17.	Thread take-up crank clamping screw:	1
18.	Thread take-up crank position screw	1
19.	Needle bar crank position screw	1
20.	Needle bar bushing (upper)	1
21.	Needle bar bushing (upper) set screw	1
22.	Needle bar bushing (upper) rubber plug	1
23.	Needle bar bushing (lower)	1
24.	Needle bar bushing (lower) set screw	1
25.	Needle bar bushing (lower) thread guard	1
26.	Needle bar	1
27.	Needle bar thread guide	1
28.	Needle	1
29.	Needle set screw	1
30.	Needle bar connecting stud slide block guide-way	1
31.	Needle bar connecting stud slide block	1
32.	Needle bar connecting stud slide block guide-way screw	1

3.

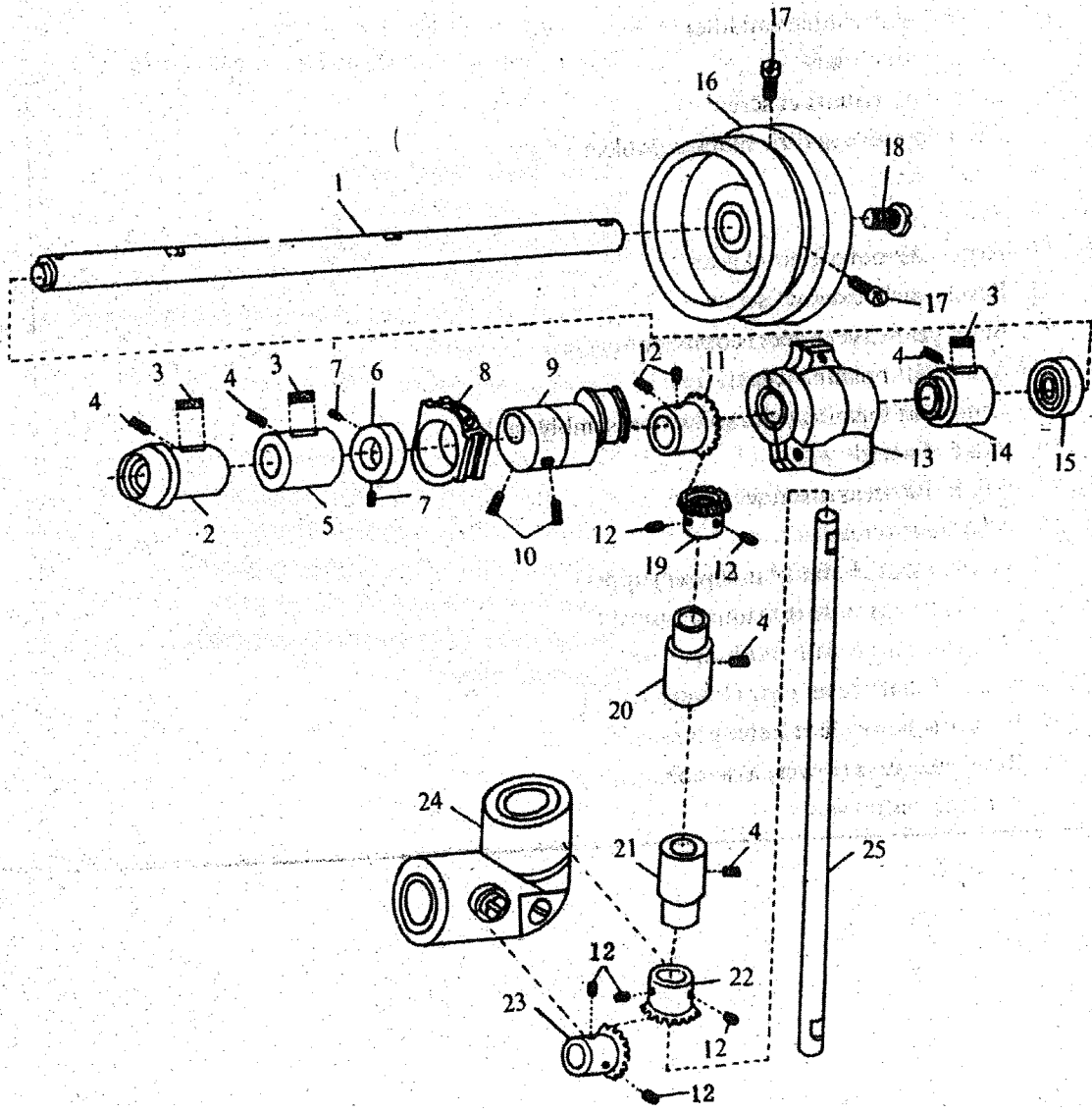

3. Arm Shaft and Vertical Shaft

Item	Description	# of Pieces
1.	Arm shaft	1
2.	Arm shaft flanged bushing (front)	1
3.	Arm shaft bushing oil pad (felt)	3
4.	Arm shaft bushing set screw	5
5.	Arm shaft bushing (middle)	1
6.	Arm shaft collar	1
7.	Arm shaft collar set screw	2
8.	Feed dog fork sliding block complete	1
9.	Feed cam	1
10.	Screw	2
11.	Arm shaft bevel gear	1
12.	Bevel gear set screw	8
13.	Bevel gear case (upper) complete	1
14.	Arm shaft bushing (rear)	1
15.	Arm shaft bushing (rear) oil seal assembly	1
16.	Balance wheel	1
17.	Balance wheel set screw	2
18.	Arm shaft screw	1
19.	Vertical shaft bevel gear (upper)	1
20.	Vertical shaft bushing (upper)	1
21.	Vertical shaft bushing (lower)	1
22.	Vertical shaft bevel gear (lower)	1
23.	Rotating hook shaft bevel gear	1
24.	Bevel gear case (lower) assembly	1
25.	Vertical shaft	1

4. Rotating Hook and Shaft

Item	Description	# of pieces
1.	Hook shaft complete	1
2.	Collar for hook shaft	1
3.	Screw	2
4.	Rear bushing	1
5.	Felt	1
6.	Screw	1
7.	Front bushing	1
8.	Felt	1
9.	Hook complete	1
10.	Screw	3
11.	Bobbin	1
12.	Bobbin case, complete	1
13.	Position finger	1
14.	Screw	1

5.

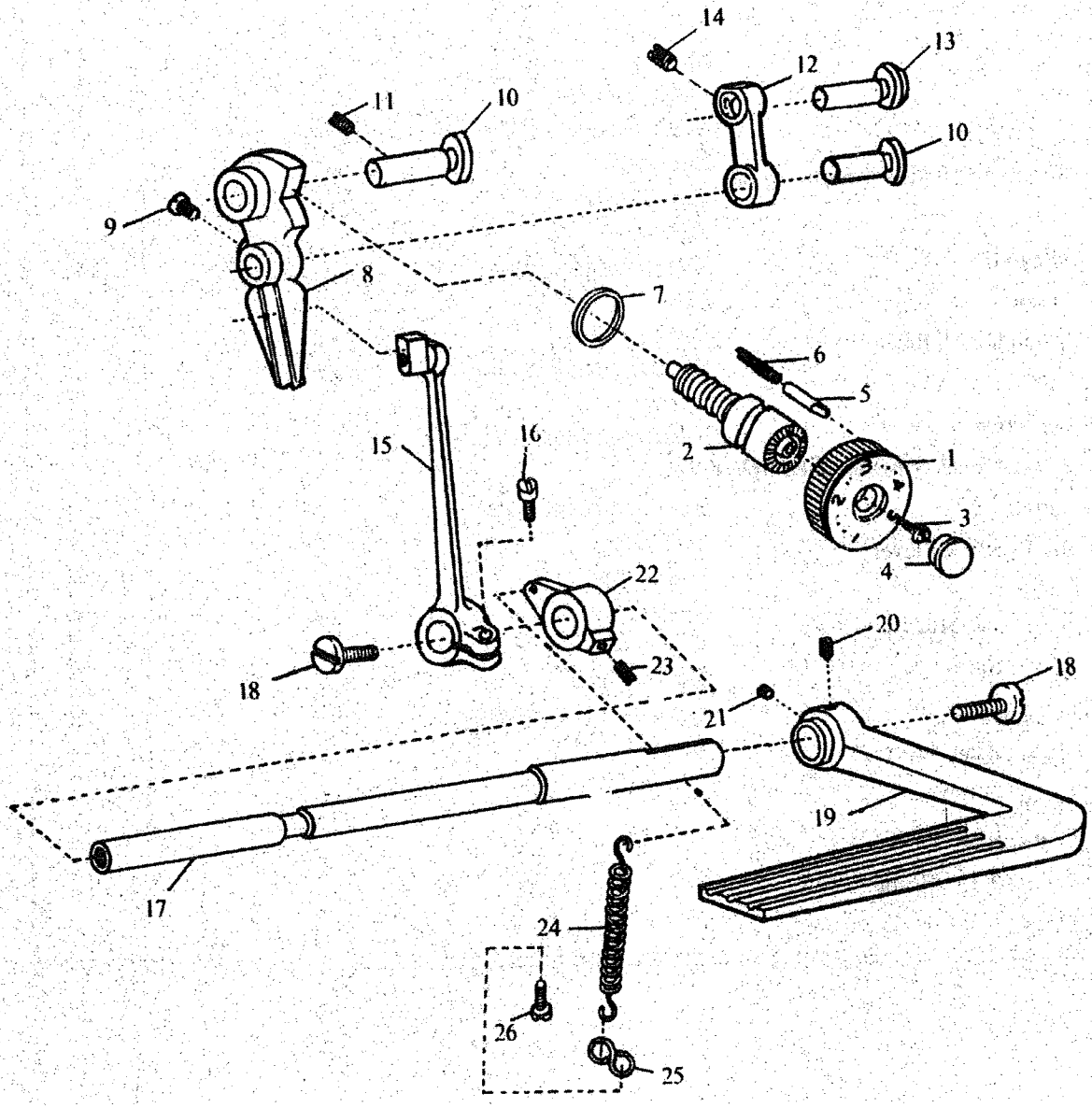

5. Stitch Length Regulating

Item	Description	# of pieces
1.	Stitch length dial	1
2.	Stitch length adjusting screw bar	1
3.	Screw	1
4.	Rubber plug	1
5.	Stop pin	1
6.	Spring	1
7.	O-type ring	1
8.	Stitch length adjusting swing bar	1
9.	Set screw	1
10.	Hinge pin	2
11.	Screw	1
12.	Stitch length link	1
13.	Pin	1
14.	Set screw	1
15.	Reverse feed swing lever, complete	1
16.	Screw	1
17.	Shaft for feed lever	1
18.	Screw	2
19.	Reverse feed lever	1
20.	Set screw	1
21.	Set screw	1
22.	Reset lever	1
23.	Screw	1
24.	Coil spring	1
25.	Set hook for spring	1
26.	Screw	1

6.

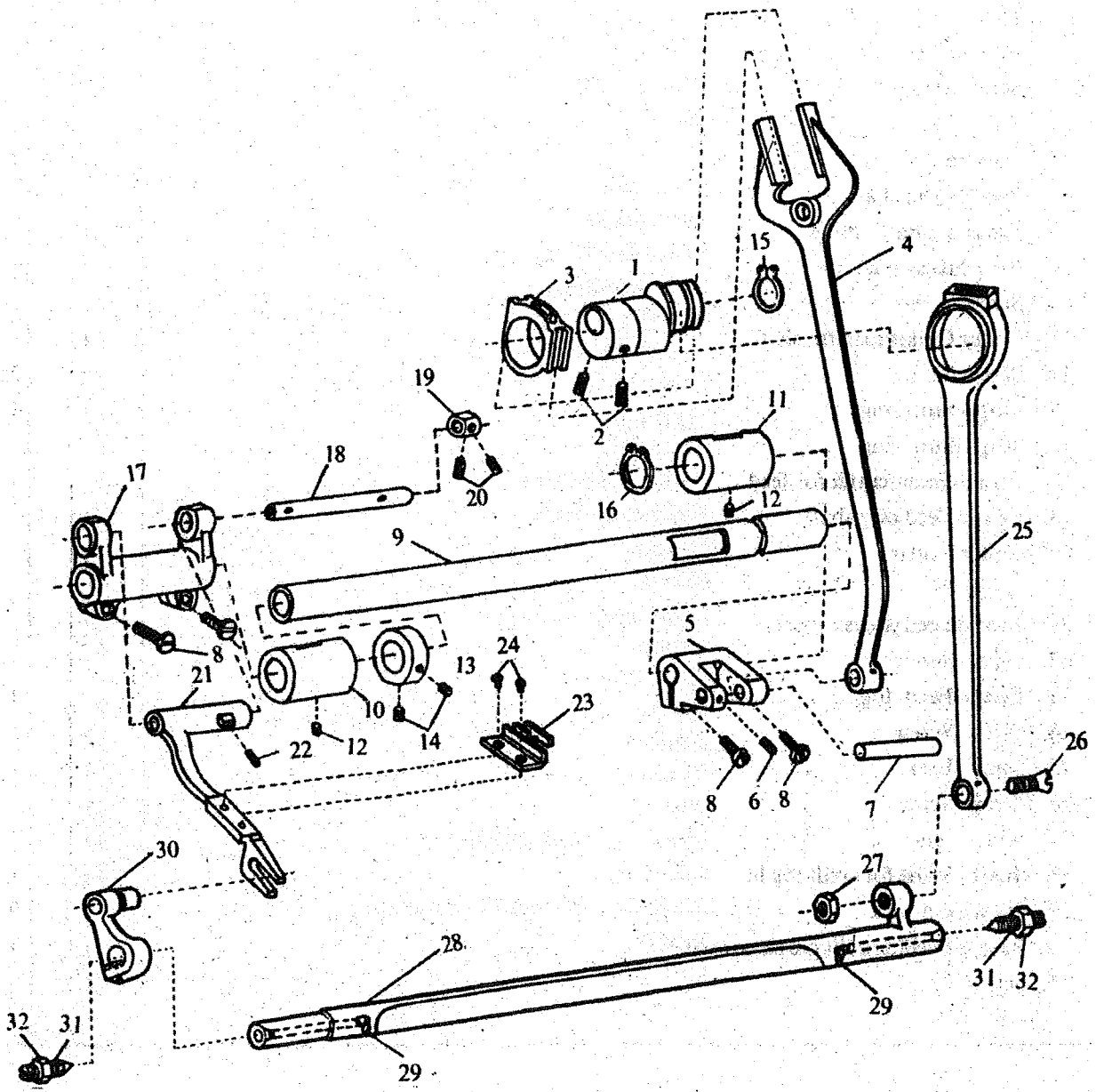

6. Bottom Feed Mechanism

Item	Description	# of pieces
1.	Feed cam	1
2.	Screw	2
3.	Fork slide block, complete	1
4.	Fork	1
5.	Feed crank	1
6.	Screw	1
7.	Pin	1
8.	Set screw	2
9.	Feed shaft	1
10.	Front bushing	1
11.	Rear bushing	1
12.	Screw	2
13.	Collar for arm shaft	1
14.	Screw	2
15.	Stop ring	1
16.	Stop ring	1
17.	Front crank for feed	1
18.	Feed dog shaft	1
19.	Collar	1
20.	Screw	2
21.	Feed dog support	1
22.	Screw	2
23.	Feed dog	1
24.	Screw	2
25.	Link	1
26.	Screw	1
27.	Nut	1
28.	Shaft for feed dog lift	1
29.	Oil wick	2
30.	Feed dog lift crank, complete	1
31.	Screw	1
32.	Nut	1

7.

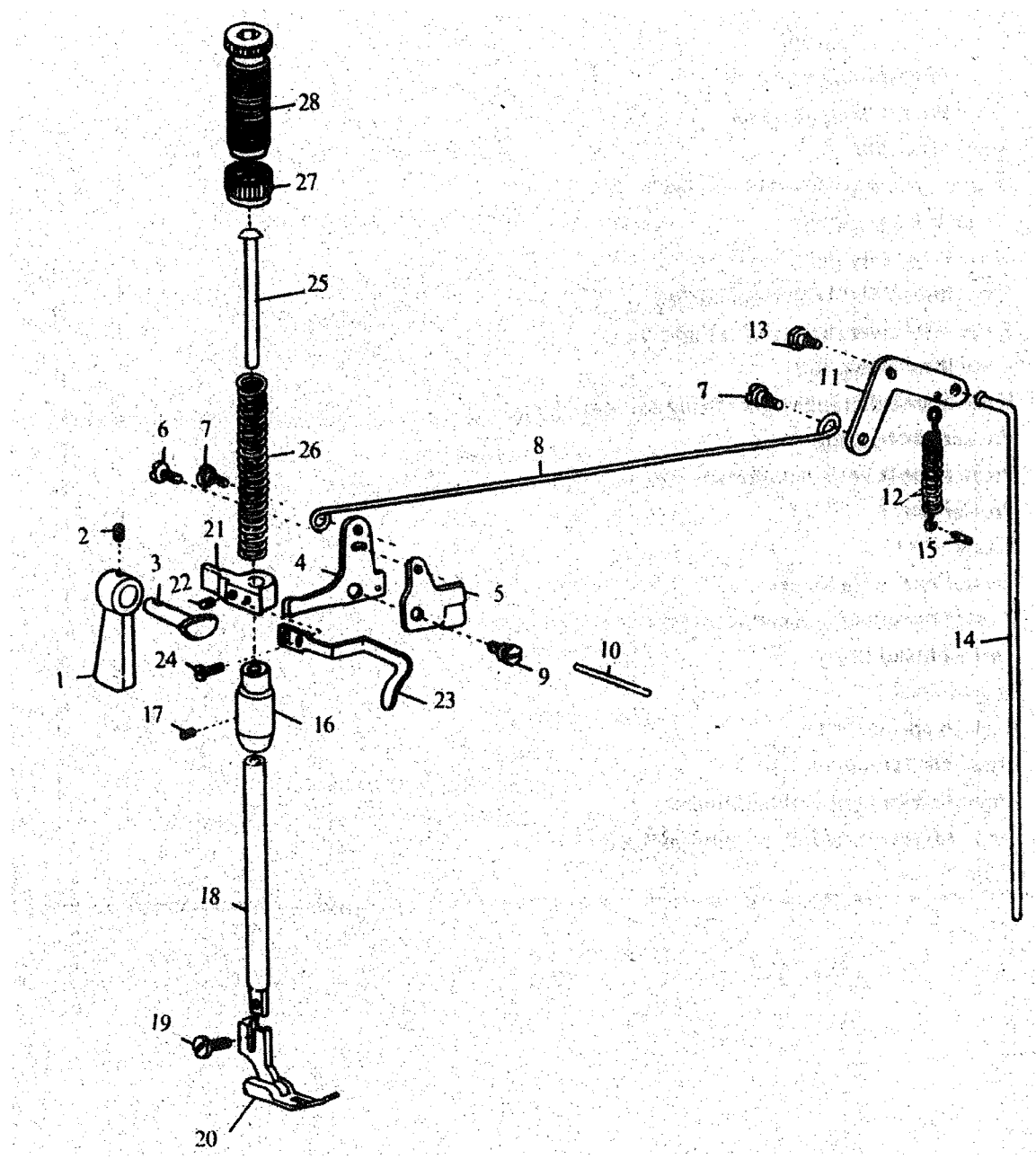

7. Presser Bar

Item	Description	# of pieces
1.	Presser bar lifter	1
2.	Presser bar lifter position screw	1
3.	Presser bar lifting cam	1
4.	Knee lifter lever (left)	1
5.	Tension releasing cam	1
6.	Knee lifter lever (left) screw	1
7.	Knee lifter link hinge screw	1
8.	Knee lifter link	2
9.	Tension releasing cam hinge screw	1
10.	Tension releasing rod	1
11.	Knee lifter lever (left) (right)	1
12.	Knee lifter lever (left) (right) spring	1
13.	Knee lifter lever (left) (right) hinge screw	1
14.	Knee lifter lifting rod	1
15.	Knee lifter bell crank (right) spring connecting pin	1
16.	Presser bar bushing	1
17.	Presser bar bushing set screw	1
18.	Presser bar	1
19.	Screw	1
20.	Presser bar guide bracket	1
21.	Presser bar guide bracket set screw	1
22.	Thread finger	1
23.	Screw	1
24.	Reel for spring	1
25.	Presser bar spring	1
26.	Pressure regulating thumb screw	1
27.	Pressure regulating thumb screw lock nut	1
28.	Screw	1

8.

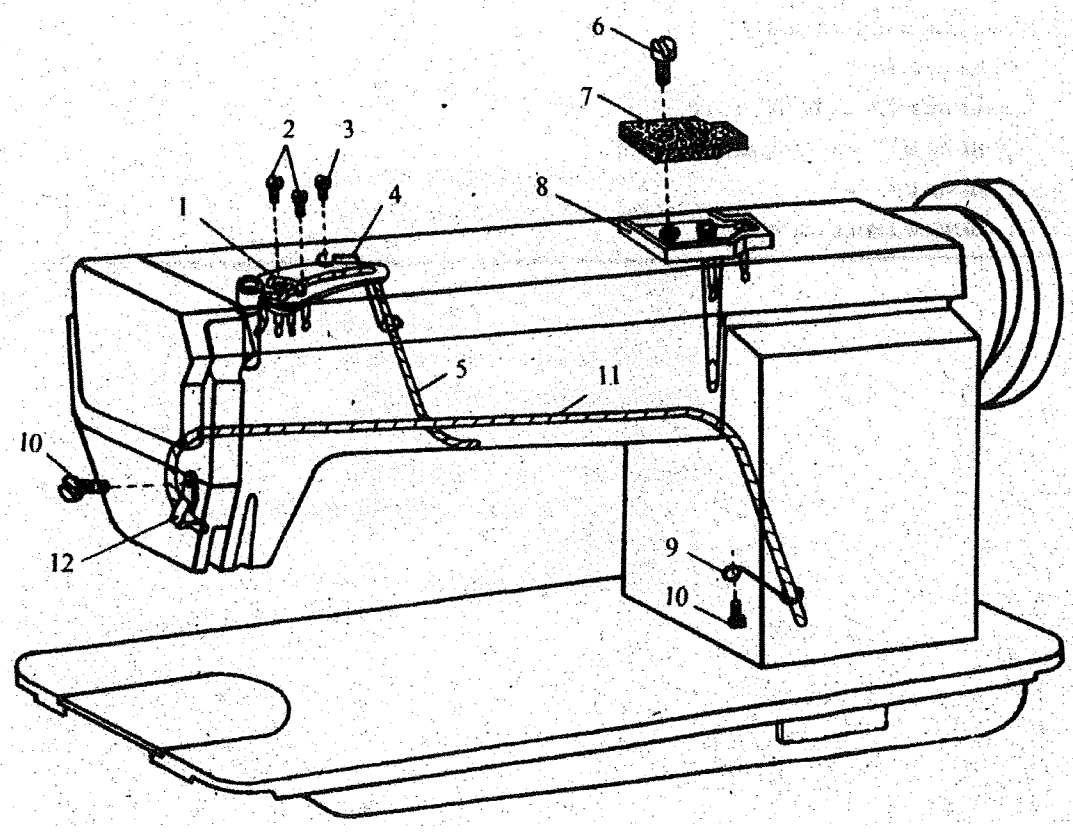

8. Lubrication

Item	Description	# of pieces
1.	Oil wick fixing plate assembly	1
2.	Oil wick fixing plate screw	2
3.	Oil wick fixing hook screw	1
4.	Oil wick fixing hook	1
5.	Wick for oil wick fixing plate	1
6.	Small oil reservoir screw	1
7.	Small oil reservoir oil pad	1
8.	Small oil reservoir	1
9.	Long oil wick fixing hook	1
10.	Long oil wick fixing hook screw	2
11.	Long oil wick	1
12.	Long oil wick clamp	1

9.

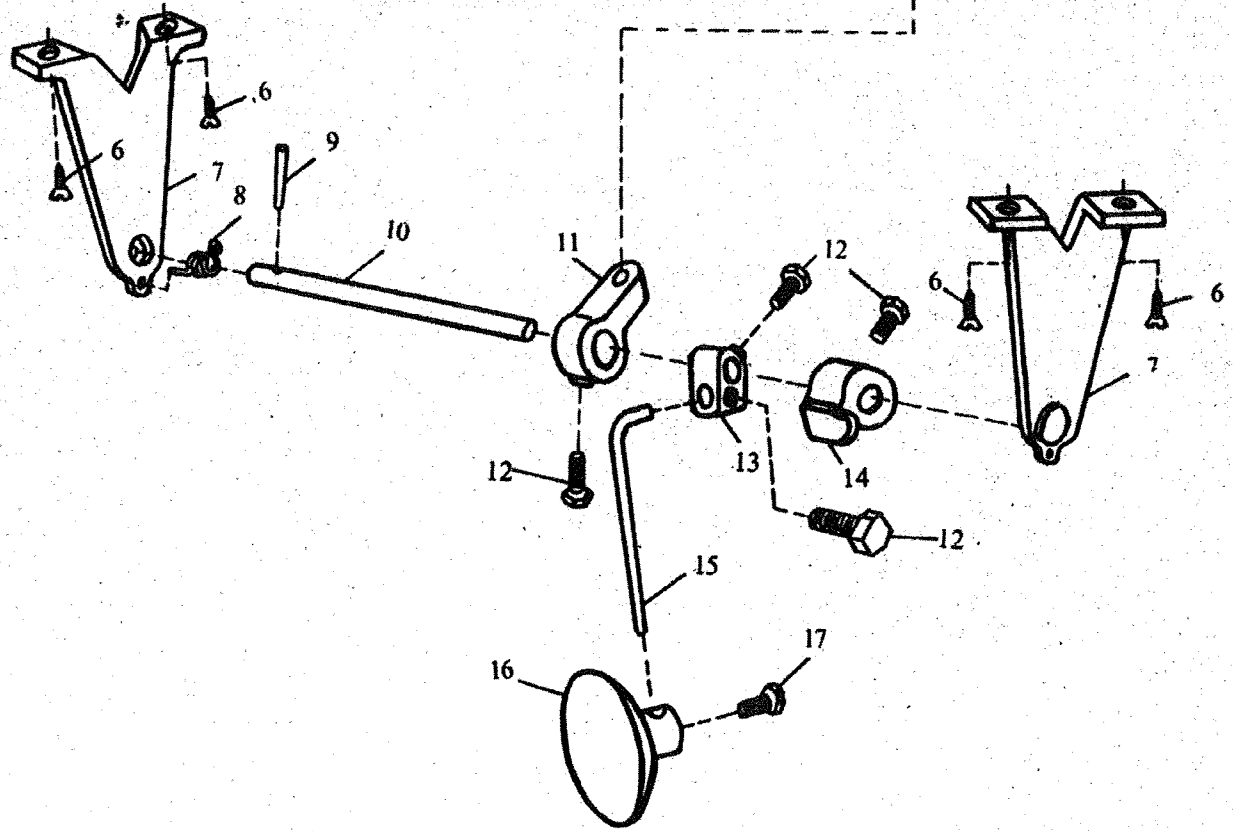
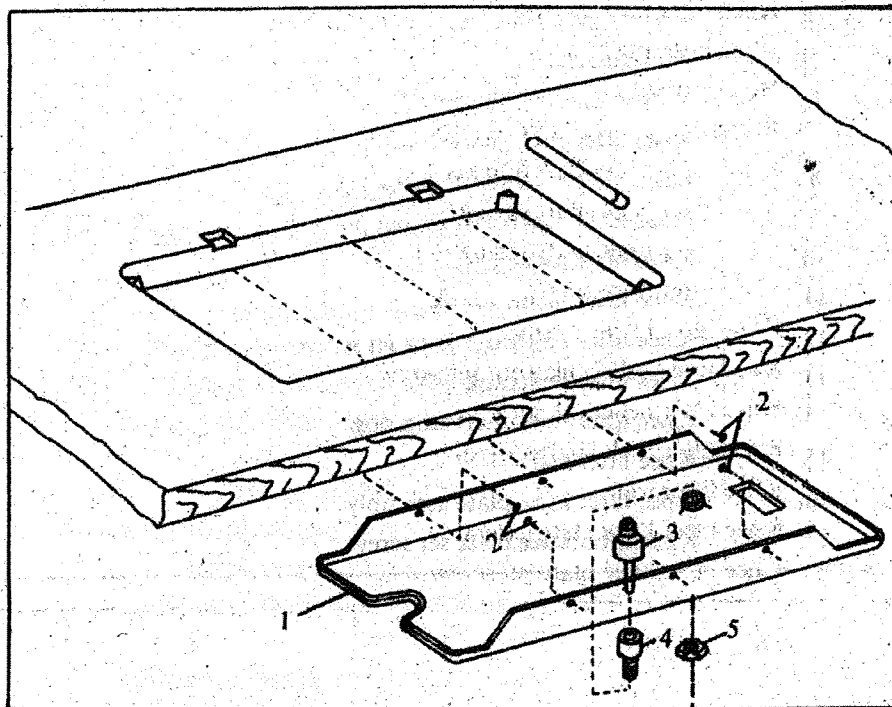

9. Drip Pan and Knee Lifter

Item	Description	# of Pieces
1.	Drip pan	1
2.	Nails	6
3.	Knee lift pushing rod	1
4.	Knee lifter pushing rod guide bushing	1
5.	Hexagon nut	1
6.	Round head wood screw	4
7.	Knee lifter rock shaft bracket	2
8.	Knee lifter rock shaft spring	1
9.	Knee lifter rock shift spring pin	1
10.	Knee lifter rock shaft	1
11.	Knee lifter lifting crank	1
12.	Knee lifter bell crank joint set screw	4
13.	Knee lifter bell crank joint	1
14.	Knee lifter rock shaft stop dog	1
15.	Knee lifter rod	1
16.	Knee lifter knee plate assembly	1
17.	Knee lifter knee plate set screw	1

10.

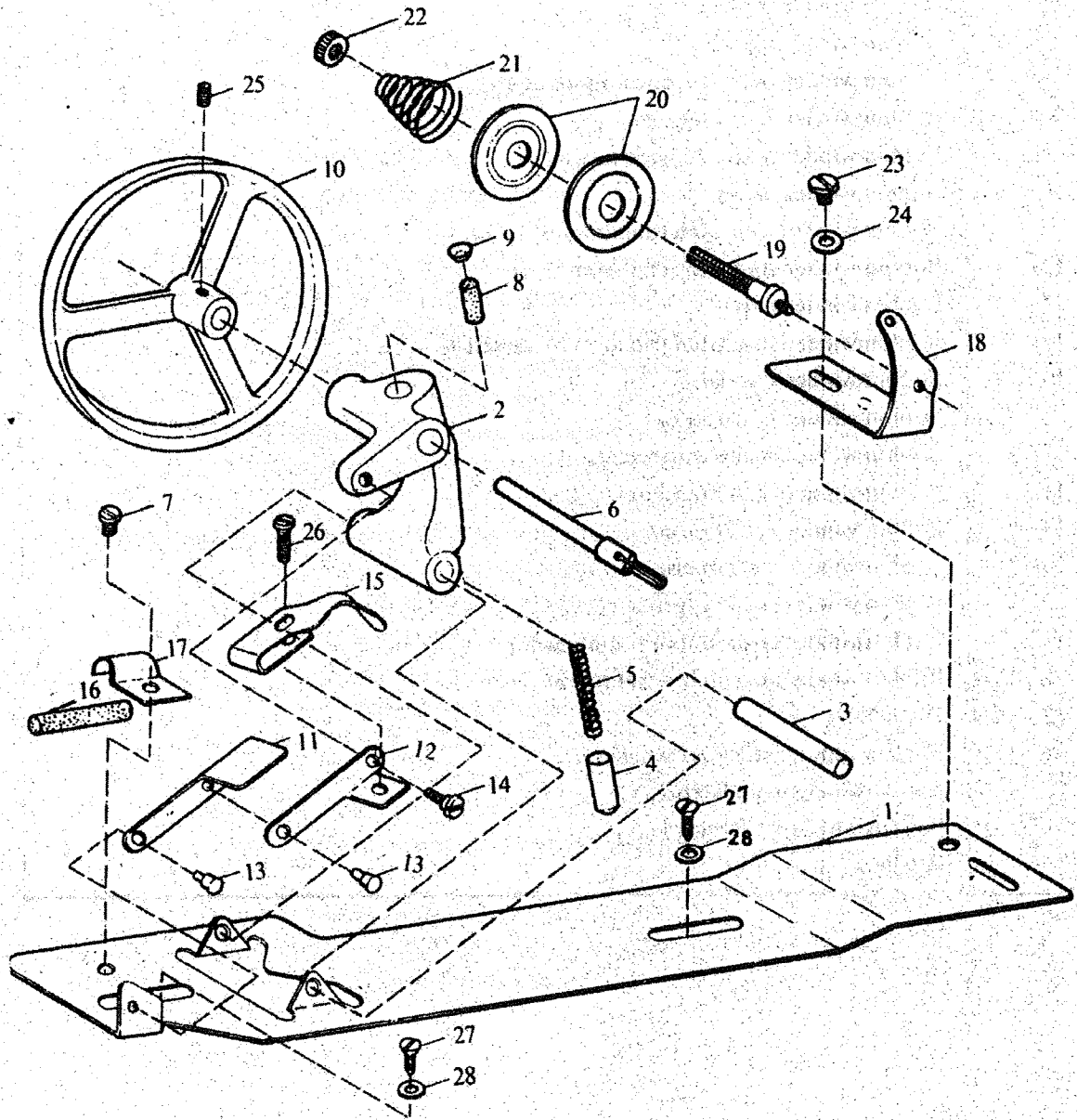

10. Bobbin Winder

Item	Description	# of pieces
1.	Bobbin winder base	1
2.	Bobbin winder frame	1
3.	Bobbin winder frame hinge pin	1
4.	Bobbin winder spring plunger	1
5.	Bobbin winder spring	1
6.	Bobbin winder spindle	1
7.	Bobbin winder brake stripe clamping screw	1
8.	Bobbin winder frame oil wick	1
9.	Bobbin winder frame oil wick cap	1
10.	Bobbin winder pulley	1
11.	Bobbin winder stop latch thumb lever	1
12.	Bobbin winder stop latch trip lever	1
13.	Bobbin winder rivet	2
14.	Bobbin winder stop latch trip lever hinge screw	1
15.	Bobbin winder stop latch	1
16.	Bobbin winder brake stripe	1
17.	Bobbin winder brake stripe clamp	1
18.	Bobbin winder tension bracket	1
19.	Bobbin winder tension stud	1
20.	Bobbin winder tension disc	2
21.	Bobbin winder tension spring	1
22.	Bobbin winder tension stud thumb nut	1
23.	Bobbin winder tension bracket screw	1
24.	Washer	1
25.	Bobbin winder pulley set screw	1
26.	Bobbin winder stop latch screw	1
27.	Bobbin winder wood screw	2
28.	Washer	2

11.

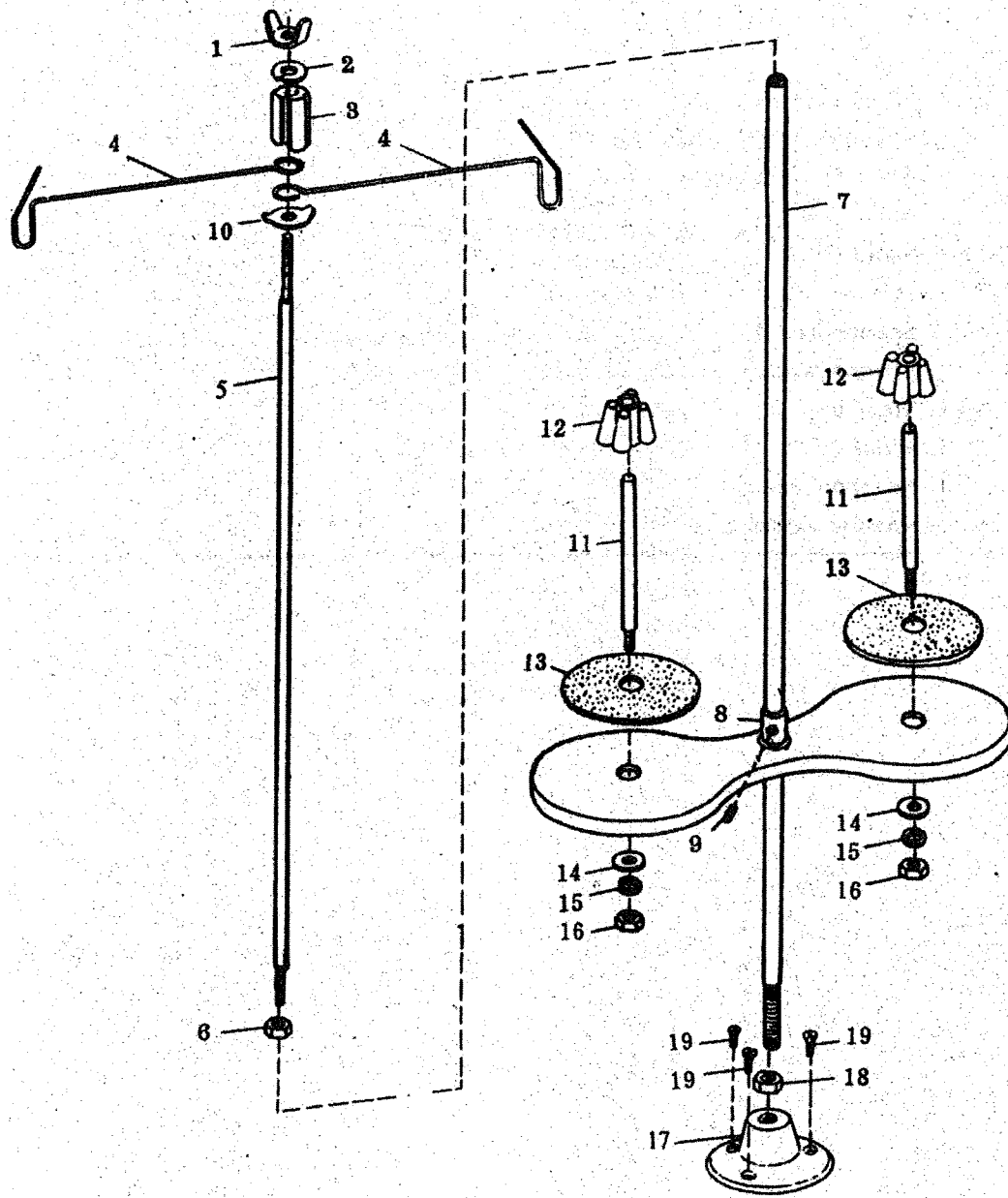

11. Spool Stand

Item	Description	# of pieces
1.	Wing nut	1
2.	Spring washer	1
3.	Thread guide position cup	1
4.	Thread guide	2
5.	Thread guide rod	1
6.	Thread guide rod nut	1
7.	Spool rest rod	1
8.	Spool rest rod sleeve	1
9.	Spool rest rod sleeve set screw	1
10.	Thread guide position plate	1
11.	Spool pin	2
12.	Spool stand	2
13.	Felt pad	2
14.	Spool pin washer	2
15.	Spool pin lock washer	2
16.	Spool pin nut	2
17.	Spool stand	1
18.	Spool rest rod nut	1
19.	Spool stand wood screw	3

12.

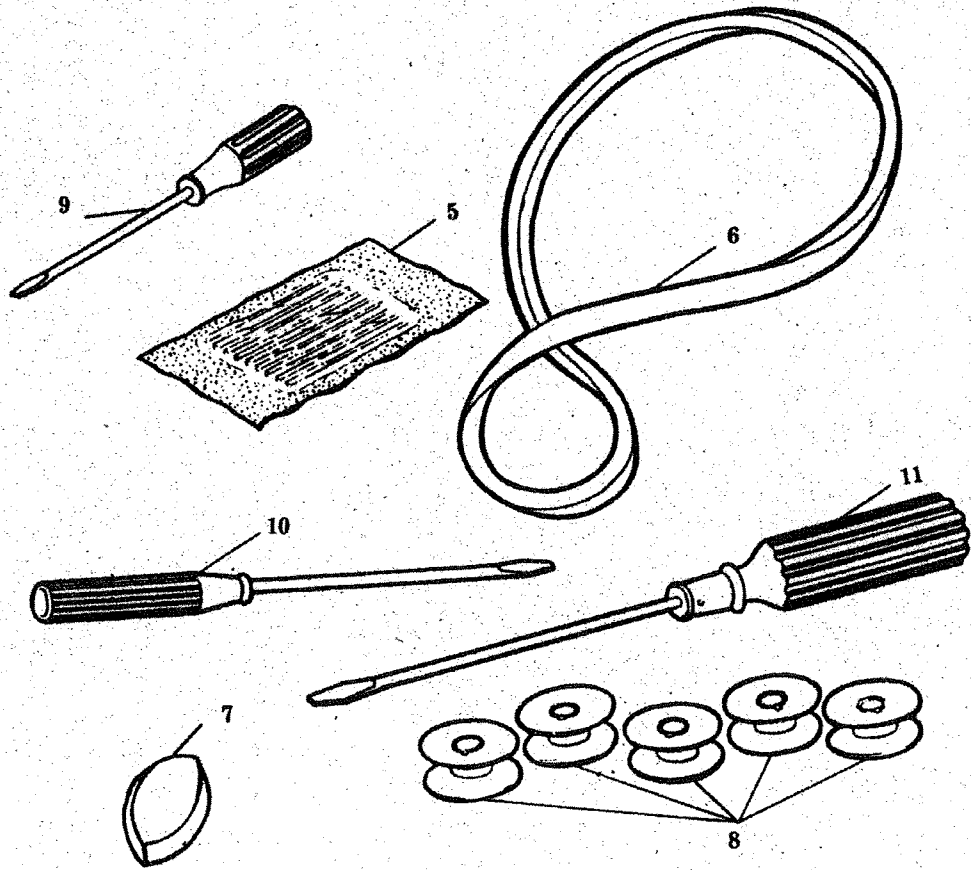
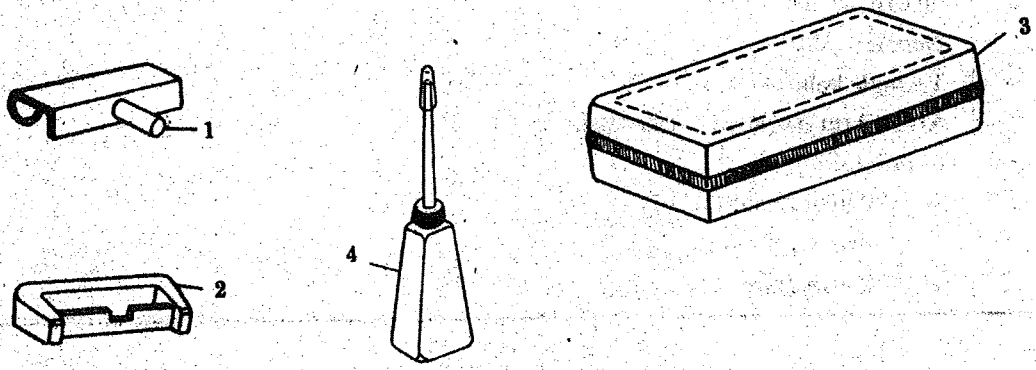

12. Accessories

Item	Description	# of pieces
1.	Arm table connecting hook	2
2.	Arm table connecting hook vibration protection tool	2
3.	Accessory box	1
4.	Oil can	1
5.	Needle	1
6.	Triangle belt	1
7.	Arm vibration proof washer block	2
8.	Bobbin	5
9.	Screw driver (small)	1
10.	Screw driver (middle)	1
11.	Screw driver (big)	1

Consolidated Sewing Machine Corp.
Website: www.consew.com

MAIN office

131 W. 25th Street
New York, NY 10001
Tel: 212-741-7788
Fax: 212-741-7787
e-mail: consew@att.net

Miami, FL

4013 N.W. 79th Avenue
Miami, FL 33166
Tel: 305-471-0200
Fax: 305-471-0243
e-mail: miamisales@consew.com

Los Angeles, CA

2320 South Hill Street
Los Angeles, CA 90007
Tel: 213-745-8844
Fax: 213-745-8855
e-mail: lasales@consew.com

