

MODEL : LK-1952/LK-1953/LK-1954

List No : 1068-05

PARTS LIST

Published:09/10/2017

CONTENTS

MACHINE FRAME & MISCELLANEOUS COMPONENTS.....	1
MAIN SHAFT & NEEDLE BAR COMPONENTS.....	5
HOOK DRIVING SHAFT COMPONENTS.....	9
FEED MECHANISM COMPONENTS(1).....	13
FEED MECHANISM COMPONENTS(2).....	17
THREAD TENSION COMPONENTS.....	21
THREAD TRIMMER COMPONENTS.....	23
THREAD PRESSER COMPONENTS.....	27
BOBBIN WINDER COMPONENTS.....	29
HOOK BASE COMPONENTS(1).....	31
HOOK BASE COMPONENTS(2).....	35
DISH RISING COMPONENTS.....	39
SAFETY COMPONENTS.....	41
LUBRICATION COMPONENTS.....	43
THREAD STAND COMPONENTS.....	47
ACCESSORY PARTS COMPONENTS.....	49
PSC BOX UNIT COMPONENTS(1).....	51
PSC BOX UNIT COMPONENTS(2).....	53
PSC BOX UNIT COMPONENTS(3).....	55
PSC BOX UNIT COMPONENTS(4).....	57
LIST FOR INFORMATION OF CHANGE.....	59
HOW TO MAKE USE OF THIS PARTS LIST.....	60

MACHINE FRAME & MISCELLANEOUS COMPONENTS

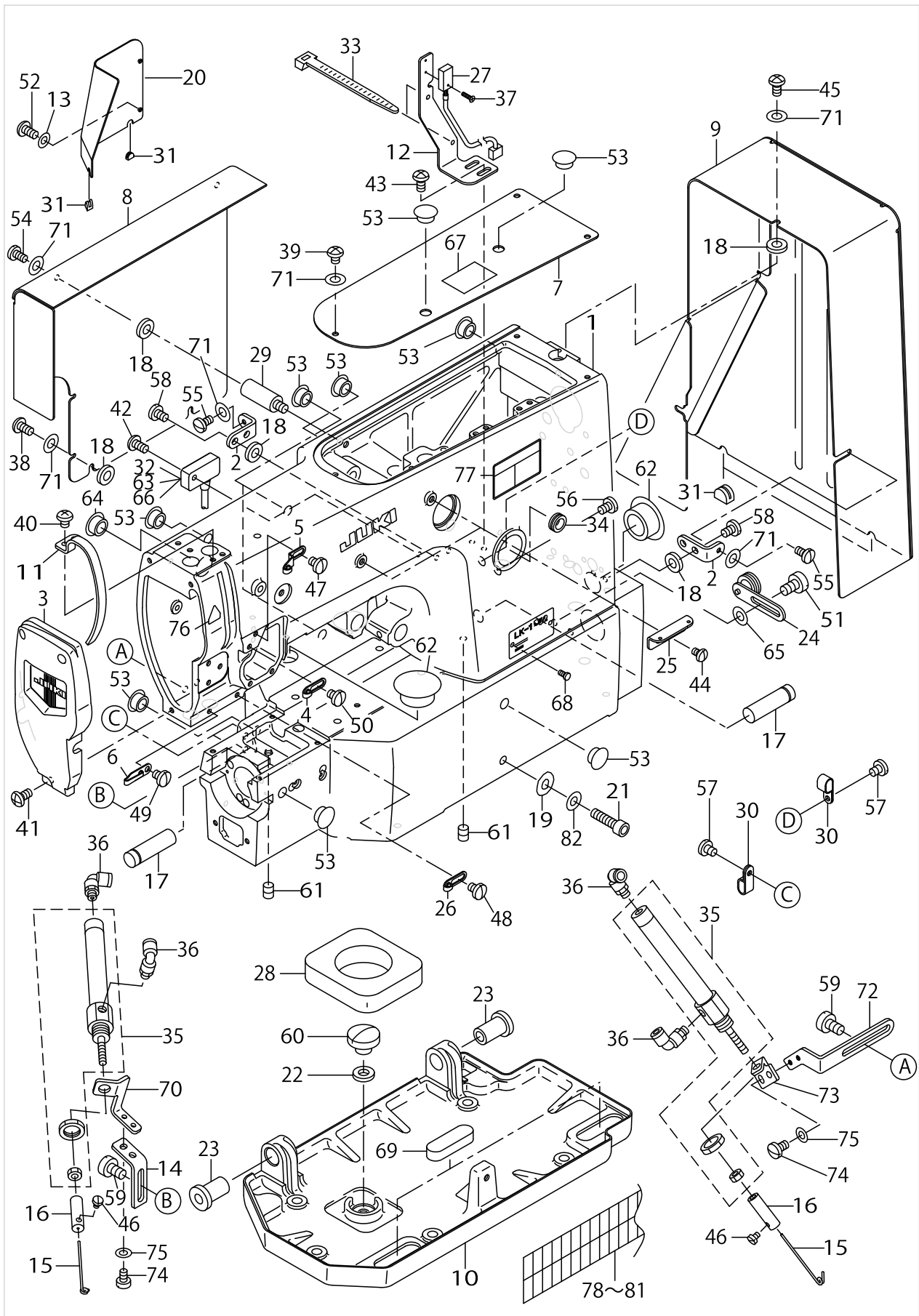

MACHINE FRAME & MISCELLANEOUS COMPONENTS

No.	Parts No.	Parts name	Remarks	Level	Cons	Qty
1	13870050	ARM BED ASM.				1
2	13870704	BELT COVER FITTING PLATE				2
3	13870852	FACE PLATE ASM.				1
4	13870902	BALANCE THREAD GUIDE, C				1
5	13871009	BALANCE THREAD GUIDE, A				1
6	13871108	BALANCE THREAD GUIDE, B				1
7	13871207	ARM COVER				1
8	13871306	SIDE COVER				1
9	13871454	BELT COVER ASM.				1
10	13871504	HEAD BASE				1
11	13871702	BALANCE COVER				1
12	13871801	SENSOR FITTING PLATE				1
13	WP0371016SD	WASHER 3.7X8X1				2
14	13872007	WIPER CYLINDER BASE, B				1
15	13872106	WIPER				2
16	13872205	WIPER PRESSER				2
17	B1107280000	BED FITTING PIN				2
18	B1144771000	FRAME SIDE COVER GASKET (C)				9
19	B1116804000	CLOTH PLATE WASHER				1
20	13871603	SIDE COVER LID				1
21	SM6083042CH	SCREW M8 L=30				1
22	13502604	SLUSH HOLE PACKING				1
23	13542006	BUSHING				2
24	13768155	V-BELT PULLEY ASM.				1
25	B2039373000	THREAD GUIDE NO.1				2
26	13922208	TAKE-UP THREAD GUIDE B				1
27	13859657	SENSOR A ASM.				1
28	B3502280000	LUBRICATING TANK FELT				1
29	B8233555000	BELT COVER SUPPORT STUD				2
30	D2112555B00	CORD HOLDER, LARGE				3
31	GPK14012000	CORD BUSHING				4
32	M6211350BAA	RESISTANCE PACK BA ASM.	FOR LK-1952			1
33	EA9500B0100	CABLE BAND				2
34	HX00221000F	BUSH				1
35	PA1004001A0	AIR CYLINDER				2
36	PJ304040504	ELBOW UNION				4
37	SM1020801SN	SCREW M2 L=8				1
38	SS4120915SP	SCREW 3/16-28 L=9				2
39	SS4120615SP	SCREW 3/16-28 L=6				3
40	SS4120615SP	SCREW 3/16-28 L=6				2
41	SS4120915SP	SCREW 3/16-28 L=9				3
42	SS4120915SP	SCREW 3/16-28 L=9				1
43	SS4120915SP	SCREW 3/16-28 L=9				2
44	SS4150915SP	SCREW 15/64-28 L=9				2
45	SS4120915SP	SCREW 3/16-28 L=9				1
46	SS6080410SP	SCREW 1/8-44 L=4				2
47	SS7120640SP	SCREW 3/16-28 L=6				1

MACHINE FRAME & MISCELLANEOUS COMPONENTS

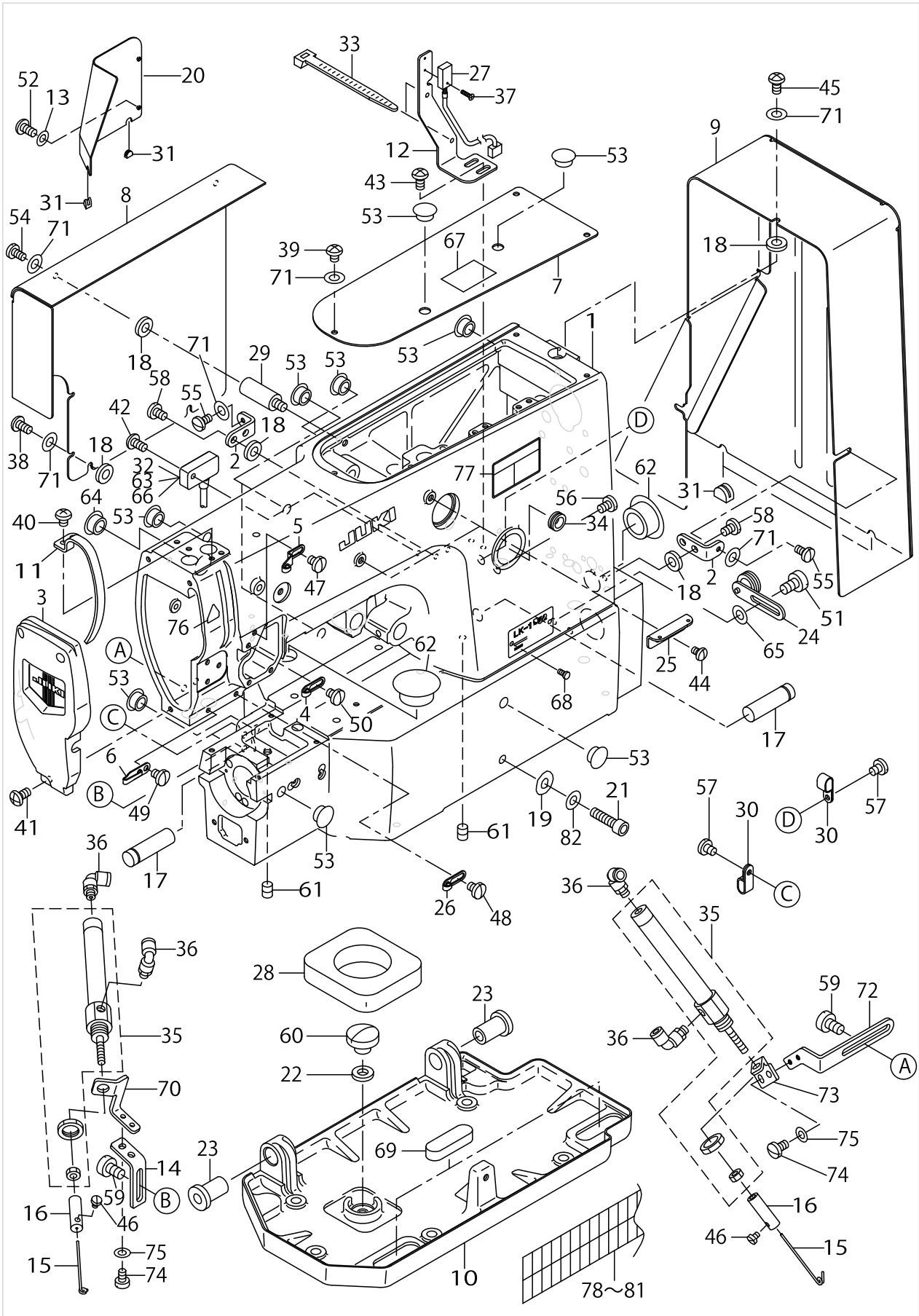

MACHINE FRAME & MISCELLANEOUS COMPONENTS

No.	Parts No.	Parts name	Remarks	Level	Cons	Qty
48	SS7120640SP	SCREW 3/16-28 L=6				1
49	SS7120640SP	SCREW 3/16-28 L=6				1
50	SS7120640SP	SCREW 3/16-28 L=6				1
51	SS6151040SP	SCREW 15/64-28 L=10				2
52	SS4090610SP	SCREW 9/64-40 L=6				2
53	TA1050504R0	RUBBER PLUG				10
54	SS7110840SP	SCREW 11/64-40 L=7.8				2
55	SS7110840SP	SCREW 11/64-40 L=7.8				2
56	SS4120615SP	SCREW 3/16-28 L=6				1
57	SS4120615SP	SCREW 3/16-28 L=6				3
58	SS6120940SP	SCREW 3/16-28 L=9				4
59	SS6151040SP	SCREW 15/64-28 L=10				4
60	SS7740740SP	SCREW 3/8-28 L= 6.5				1
61	SS8150710TP	SCREW 15/64-28 L=7				2
62	TA2050416R0	RUBBER PLUG				2
63	M6212350BAA	RESISTANCE PACK BA ASM.	FOR LK-1953			1
64	TA2100904R0	RUBBER PLUG				1
65	WP0703216SP	WASHER				2
66	M6213350BAA	RESISTANCE PACK BA ASM.	FOR LK-1954			1
67	B1135210000	SEAL				1
68	11001005	SCREW				1
69	B1104280000	VIBRATION-PROOF RUBBER PAD				2
70	13872304	WIPER CYLINDER BASE (C)				1
71	WP0480856SP	WASHER 4.8X8.4X0.8				10
72	13879804	WIPER CYLINDER BASE (A)				1
73	13879903	WIPER CYLINDER BASE (D)				1
74	SS7110710SP	SCREW 11/64-40 L=7				4
75	WP0480856SP	WASHER 4.8X8.4X0.8				4
76	CM3002000B1	LABEL(16)				1
77	CM300200101	SAFETY LABEL, 1(SMALL).				1
78	18036707	WIRE MARK (18)				2
79	18036806	WIRE MARK (19)				2
80	18036905	WIRE MARK (20)				1
81	18037002	WIRE MARK (21)				1
82	WP0850002SP	WASHER 8.5X18X1.6				1

MAIN SHAFT & NEEDLE BAR COMPONENTS

No.	Parts No.	Parts name	Remarks	Level	Cons	Qty
1	13873005	MAIN SHAFT				1
2	13873104	UPPER SHAFT REAR METAL				1
3	13873260	DRIVING PULLEY COMBINE				1
4	13873252	DRIVING PULLEY ASM.		*		1
5	13872650	MAGNET FITTING BASE COMPL. A		*		1
6	SS8151770SP	SCREW 15/64-28 L=17.0		*		1
7	SS8151550SP	SCREW 15/64-28 L=15		*		1
8	SS6111210SP	SCREW 11/64-40 L=12		*		1
9	WP0450801SD	WASHER 4.5X10X0.8		*		1
10	13873302	BOSS				2
11	13873658	IDLER FITTING PLATE				1
12	13873708	TIMING BELT				1
13	13873807	UPPER SHAFT SPROCKET				1
14	13873906	CONTERWEIGHT				1
15	11032265	GENERATOR STARTER ASM.				1
16	13503206	UPPER SHAFT FRONT METAL				1
17	13503305	UPPER SHAFT INNER METAL				1
18	13503404	THREAD TRIMMING CAM				1
19	B120898000A	MAIN SHAFT NEEDLE BEARING A	SELECTIVE PART			1
20	B120898000B	MAIN SHAFT NEEDLE BEARING B	SELECTIVE PART			1
21	B120898000C	MAIN SHAFT NEEDLE BEARING C	SELECTIVE PART			1
22	B120898000D	MAIN SHAFT NEEDLE BEARING D	SELECTIVE PART			1
23	B1210980000	SET SCREW				1
24	B1211980000	UPPER SHAFT THRUST BEARING				2
25	B1220771000	THRUST WASHER A				1
26	B1223771000	NEEDLE ROD CRANK WASHER				1
27	B1211804000	BALL BEARING B				4
28	RC0150001KP	RETAINING RING 13.8				1
29	SL4051001MZ	SCREW M5 L=9.6				2
30	SS6151412TP	SCREW 15/64-28 L=14				1
31	SS6681712TP	SCREW 9/32-28 L=16.5				1
32	SS7151310TP	SCREW				4
33	SS8660610TP	SCREW 1/4-40 L=6				1
34	SS8660612TP	SCREW 1/4-40 L=6				2
35	SS8661012TP	SCREW				1
36	SS8661212TP	SCREW				1
37	SS9661230CP	SCREW 1/4-40 L=12				1
38	13874508	NEEDLE FITTING BASE				2
39	13874607	NEEDLE BAR GUIDE				1
40	13874706	NEEDLE BAR				1
41	13874805	NEEDLE BAR CONNECTION, B				1
42	13874904	NEEDLE BAR CONNECTION, A				1
43	13875000	GUIDE SUPPORT SHAFT				1
44	13875109	UPPER METAL, A				1
45	13875208	LOWER METAL, A				1
46	13875760	BALANCE COMBINE				1
47	13875752	BALANCE ASM.		*		1

MAIN SHAFT & NEEDLE BAR COMPONENTS

No.	Parts No.	Parts name	Remarks	Level	Cons	Qty
48	13875307	NEEDLE BAR CRANK ROD		*		1
49	13875406	NEEDLE BAR CRANK		*		1
50	13875810	THREAD TAKE-UP CRANK		*		1
51	13875919	NEEDLE BEARING SHAFT		*		1
52	B1903552000	LEFT SCREW		*		1
53	B1430180A00	NEEDLE BEARING	SELECTIVE PART	*		1
54	B1430180B00	NEEDLE BEARING	SELECTIVE PART	*		1
55	B1430180C00	NEEDLE BEARING C	SELECTIVE PART	*		1
56	B1430180D00	NEEDLE BEARING	SELECTIVE PART	*		1
57	SB30400020A	BUSHING	SELECTIVE PART	*		1
58	SB30800080A	BUSHING	SELECTIVE PART	*		1
59	SB30800080B	BUSHING	SELECTIVE PART	*		1
60	SB30800080C	BUSHING	SELECTIVE PART	*		1
61	SB30800080D	BUSHING	SELECTIVE PART	*		1
62	13876008	UPPER METAL, B				1
63	13876107	LOWER METAL, B				1
64	B1414232000	SQUARE BLOCK	SELECTIVE PART			1
65	B141423200A	CRANK SLIDE BLOCK	SELECTIVE PART			1
66	B141423200B	GUIDE ROLLER	SELECTIVE PART			1
67	B3035280000	SAFETY PLATE SLIDE BLOCK				1
68	B1904280000	BALANCE CRANK PIN				1
69	MDP170B2100	NEEDLE DPX17 #21				2
70	SM6860552TP	SCREW M2.6X0.45 L=5				2
71	SS6090670TP	SCREW 9/64-40 L=6				1
72	SS6110820TP	SCREW 11/64-40 L=8				1
73	SS6090810TP	SCREW 9/64-40 L=7.5				1
74	SS7110840SP	SCREW 11/64-40 L=7.8				2
75	SS7151120SP	SCREW 15/64-28 L=11				1
76	13890009	WORM 28	FOR LK-1952			1
77	13890108	WORM 36	FOR LK-1953			1
78	13890207	WORM 42	FOR LK-1954			1
79	SS7111410TP	SCREW 11/64-40 L=14				4
80	MDP170B1900	NEEDLE DPX17 #19	FOR LK-195ΔA			2
81	SS6151220SP	SCREW 15/64-28 L=11.5				2
82	SS8150822TP	SCREW 15/64-28 L=8				1
83	SS8150510TP	SCREW 15/64-28 L= 4.7				1
84	MTJVH00500A	V BELT, 50				1

HOOK DRIVING SHAFT COMPONENTS

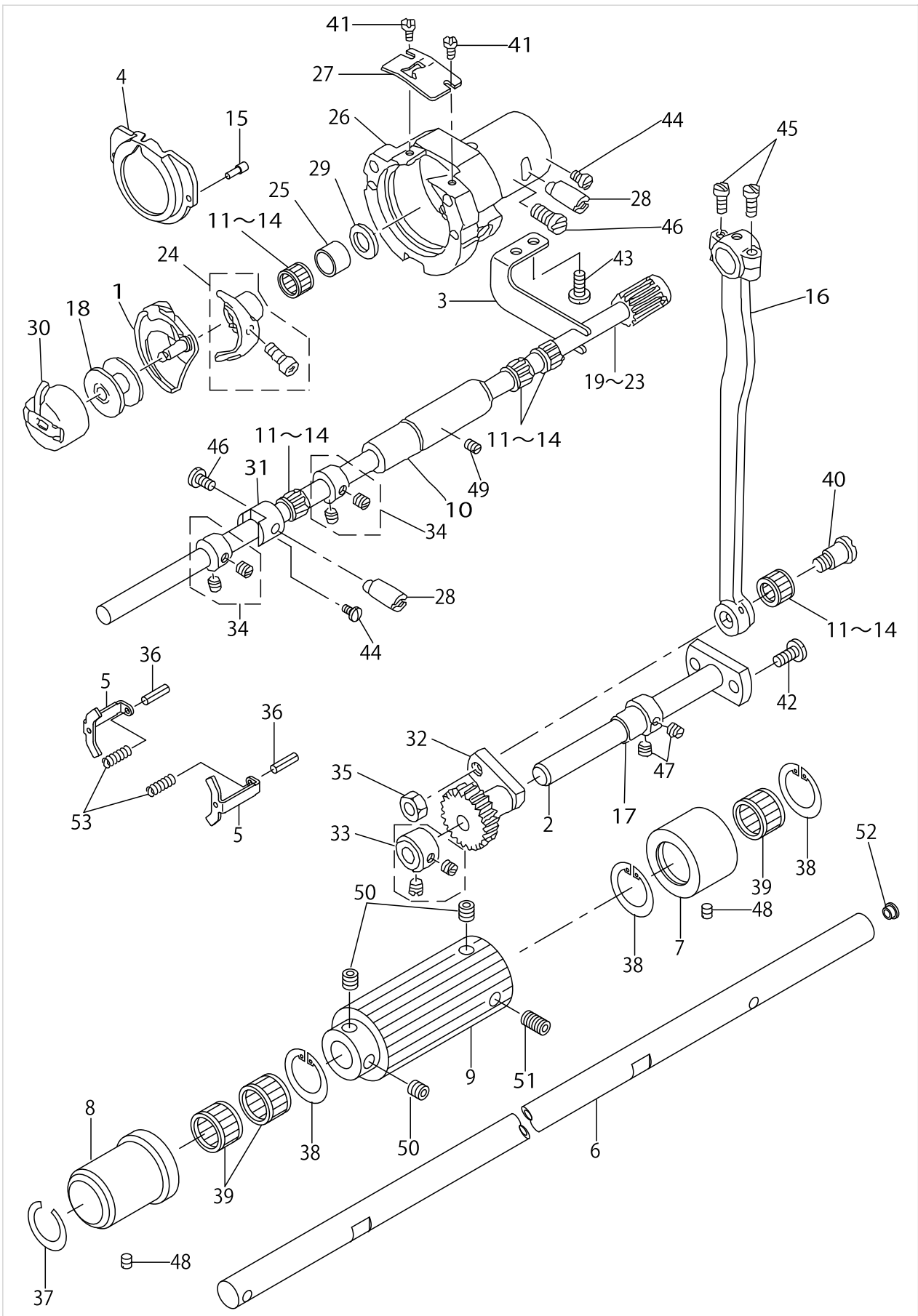

HOOK DRIVING SHAFT COMPONENTS

No.	Parts No.	Parts name	Remarks	Level	Cons	Qty
1	13876305	INNER HOOK				1
2	13876404	OSCILLATING SHAFT				1
3	13876503	BEARING SUPPORT				1
4	13876602	INNER HOOK PRESSER				1
5	13876719	INNER HOOK PRESSER HOOK				2
6	13876800	REMOVING SHAFT				1
7	13876909	REAR METAL				1
8	13877006	INNER METAL				1
9	13877105	SPROCKET				1
10	13508403	LOWER SHAFT REAR METAL				1
11	B1411804A00	BEARING (A)	SELECTIVE PART			5
12	B1411804B00	NEEDLE DRIVING LEVER BEARING B	SELECTIVE PART			5
13	B1411804C00	NEEDLE DRIVING LEVER BEARING C	SELECTIVE PART			5
14	B1411804D00	BEARING (D)	SELECTIVE PART			5
15	B1816280000	GUIDE PIN				2
16	B1801980000	CRANK ROD				1
17	B1804280000	OSCILLATOR THRUST COLLAR,LARGE				1
18	B1805210A00	BOBBIN				1
19	B18069800AA	SHUTTLE DRIVER SHAFT	SELECTIVE PART			1
20	B18069800AB	LOWER SHAFT GEAR ASM., B	SELECTIVE PART			1
21	B18069800AC	LOWER SHAFT GEAR ASM., C	SELECTIVE PART			1
22	B18069800AY	LOWER SHAFT GEAR ASM., Y	SELECTIVE PART			1
23	B18069800AZ	LOWER SHAFT GEAR ASM., Z	SELECTIVE PART			1
24	B18122100A0	DRIVER ASM.				1
25	B1813980000	SHUTTLE NEEDLE OUTER RING				1
26	B1814980000	SHUTTLE				1
27	B1815210000	INNER HOOK UPPER SPRING				1
28	B1819280000	SHUTTLE RACE ADJUSTING SHAFT				2
29	WP0952616SD	WASHER 9.5X14.8X2.6				1
30	B18282100A0	BOBBIN CASE ASM.				1
31	B1831220000	BUSHING, FRONT				1
32	D1805MLBH00	OSCILLATING ROCK SHAFT				1
33	CS079073ASH	THRUST COLLAR ASM.				1
34	CS080081ASH	THRUST HOLDER ASM. D=8 W=8				2
35	NS6660430SP	NUT 1/4-40				1
36	PS0250162KH	SPRING PIN 2.5X16				2
37	RC1991214KP	C-RING				1
38	RC2200002KP	RETAINING RING				3
39	SB312000400	BUSHING				3
40	SD0801021TP	HINGE SCREW D= 8 H=10.2				1
41	SS6060410TP	SCREW 3/32-56 L= 3.5				2
42	SS6121010SP	SCREW 3/16-28 L=10				2
43	SS6121010SP	SCREW 3/16-28 L=10				2
44	SS7110840SP	SCREW 11/64-40 L=7.8				2
45	SS7111110TP	SCREW 11/64-40 L=10.5				2
46	SS7151120SP	SCREW 15/64-28 L=11				2
47	SS8110520SP	SCREW 11/64-40 L=5				2

HOOK DRIVING SHAFT COMPONENTS

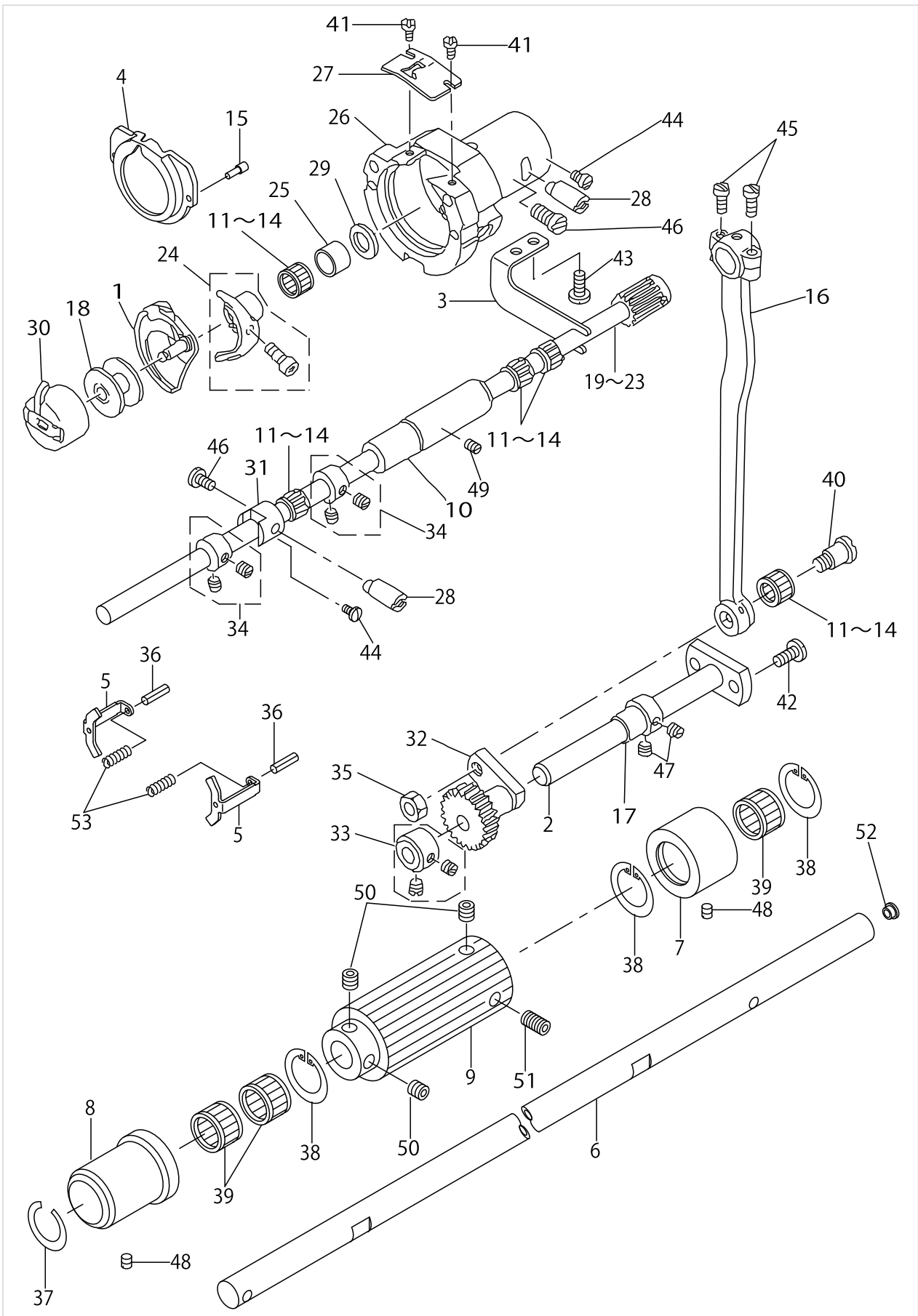

HOOK DRIVING SHAFT COMPONENTS

No.	Parts No.	Parts name	Remarks	Level	Cons	Qty
48	SS8150710TP	SCREW 15/64-28 L=7				2
49	SS8150710TP	SCREW 15/64-28 L=7				1
50	SS8660612TP	SCREW 1/4-40 L=6				3
51	SS8661212TP	SCREW				1
52	TA0750404R0	PLUG D=7.5 L=3.5				1
53	B1823280000	INNER HOOK PRESSER SPRING				2

FEED MECHANISM COMPONENTS(1)

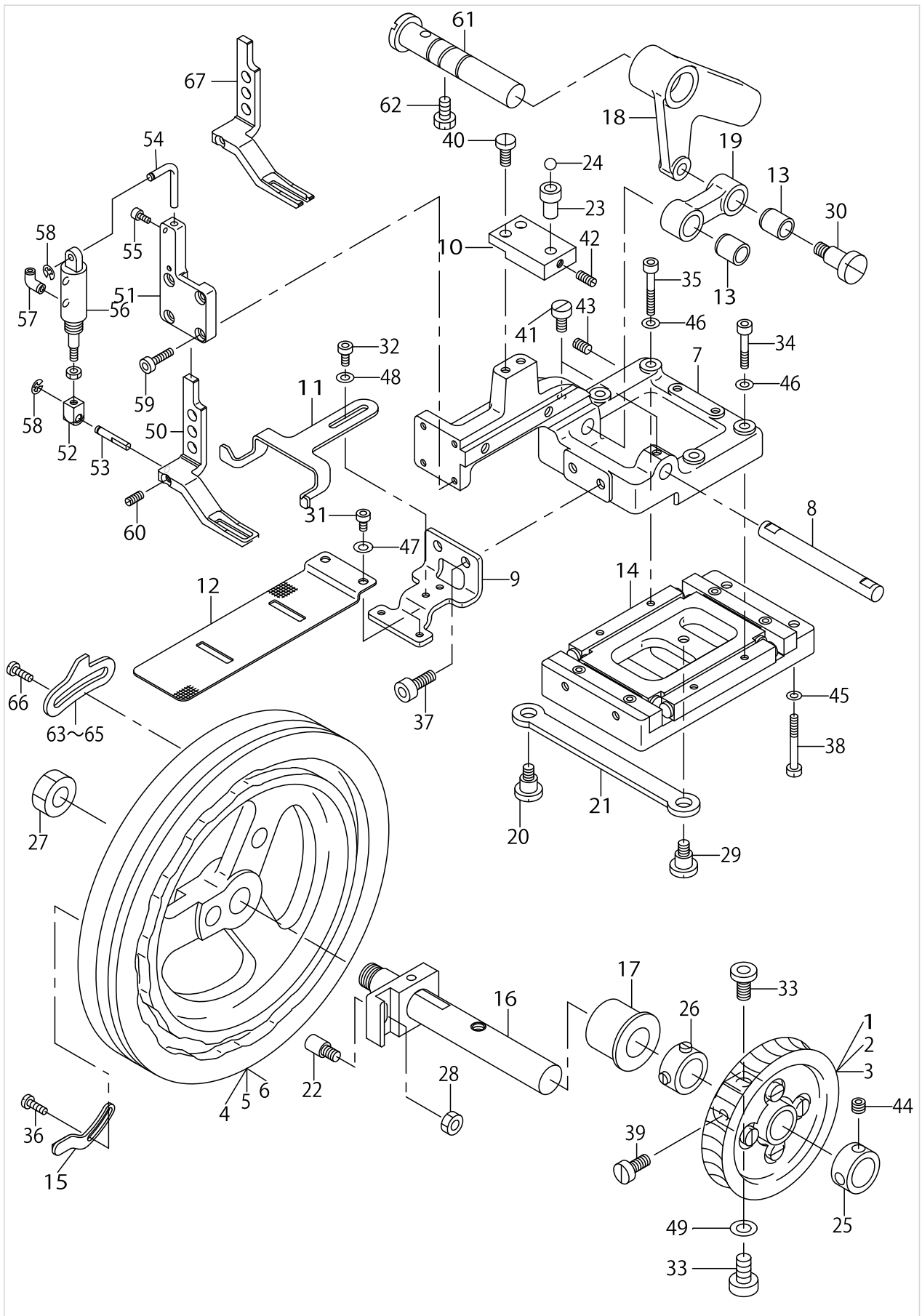

FEED MECHANISM COMPONENTS(1)

No.	Parts No.	Parts name	Remarks	Level	Cons	Qty
1	13878053	WORM GEAR ASM. (28 STITCHES)	FOR LK-1952			1
2	13878251	WORM GEAR ASM.	FOR LK-1954			1
3	13878152	WORM GEAR ASM.	FOR LK-1953			1
4	13878707	CLOTH FEED CAM	FOR LK-1952			1
5	13878905	CLOTH FEED CAM.	FOR LK-1954			1
6	13878806	CLOTH FEED CAM.	FOR LK-1953			1
7	13879705	CLOTH FEED BRACKET				1
8	13880109	FEED CONNECTING SHAFT				1
9	13880208	CLOTH FEED PLATE BASE				1
10	13880505	BOLL HOLDING BASE				1
11	13880307	CLOTH FEED PLATE GUIDE				1
12	13880406	CLOTH PRESSER LOWER PLATE				1
13	13879408	METAL				2
14	13880000	X-Y TABLE				1
15	13867957	MAGNET B ASM.				1
16	13878558	CAM SHAFT ASM.				1
17	13878608	CAM SHAFT METAL				1
18	13879200	VERTICAL FEED LEVER				1
19	13879309	CONNECTING LEVER				1
20	B1605761000	LENGTH REGULATING HINGE STUD				1
21	B1606761000	WORK CLAMP ARM BRACKET PITMAN				1
22	B2207280000	FEED CAM POSITION STUD				1
23	B2548280000	BALL RETAINER				1
24	B2549280000	WORK CLAMP FOOT MOUNTING BASE				7
25	CS1801211SH	THRUST COLLAR D=18 W=12				1
26	CS180121ASH	THRUST COLLAR ASM. D=18 W=12				1
27	NS6361040SP	NUT 9/16-20				1
28	NS6660511SP	NUT 1/4				1
29	SD0870602SP	HINGE SCREW D= 8.73 H= 6.0				1
30	SD0951501SP	HINGE SCREW D= 9.53 H=15				1
31	SM6040602TN	BOLT				2
32	SM6040602TN	BOLT				2
33	SM6081552TP	SCREW M8 L=15				2
34	SM6052002TP	SCREW M5 L=20				2
35	SM6052502TP	SCREW M5X0.8 L=25				2
36	SS6090520SP	SCREW 9/64-40 L= 5.0				2
37	SS6151412TP	SCREW 15/64-28 L=14				2
38	SS6153040SP	SCREW 15/64-28 L=30				4
39	SS6661110SP	SCREW 1/4-40 L=11				1
40	SS6121210SP	SCREW 3/16-28 L=12				2
41	SS7120910SP	SCREW 3/16-28 L=9				2
42	SS8120740SP	SCREW 3/16-28 L=7				1
43	SS8120740SP	SCREW 3/16-28 L=7				2
44	SS8660410SP	SCREW 1/4-40 L= 4.2				2
45	WP0612516SD	WASHER 6.1X15.2X2.5				4
46	WP0550800SP	WASHER 5.5X10X0.8				4
47	WP0450826SC	WASHER 4.5X10X0.8				2

FEED MECHANISM COMPONENTS(1)

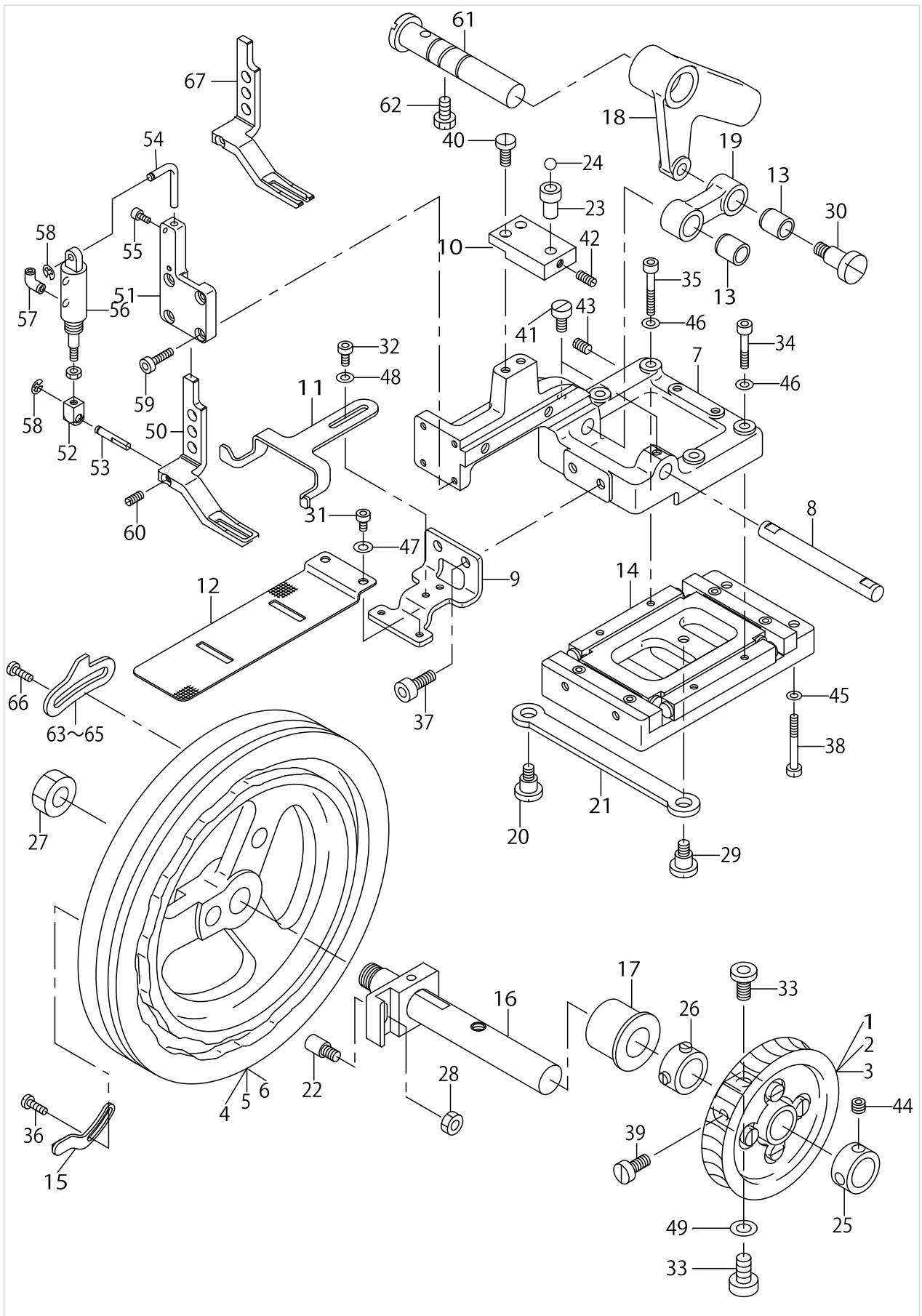

FEED MECHANISM COMPONENTS(1)

No.	Parts No.	Parts name	Remarks	Level	Cons	Qty
48	WP0450826SC	WASHER 4.5X10X0.8				2
49	WS0822010KP	SPRING WASHER 8.2X15X2				1
50	13875604	CLOTH PRESSER FOOT				1
51	13877907	CLOTH PRESSER BASE COVER				1
52	13880604	WASHER				1
53	13880703	CYLINDER PIN				1
54	13880802	L-TYPE CYLINDER BASE				1
55	SM6030860SP	SCREW				1
56	PA1002501A0	CYLINDER				1
57	PJ304040504	ELBOW UNION				2
58	RE0300000K0	E-RING 3				2
59	SM6041202TN	SCREW M4X0.7 L=12				4
60	SS8110422TP	SCREW 11/64-40 L=4				1
61	13516208	FEED DRIVING ARM SHAFT				1
62	SS9151210TP	SCREW 15/64-28 L=11.8				1
63	13884408	DISH RISING NOTCH	FOR LK-1952			1
64	13884804	DISH RISING NOTCH	FOR LK-1953			1
65	13884903	DISH RISING NOTCH	FOR LK-1954			1
66	SS6151040SP	SCREW 15/64-28 L=10				2
67	13877808	CLOTH PRESSER FOOT	FOR LK-195△F			1

FEED MECHANISM COMPONENTS(2)

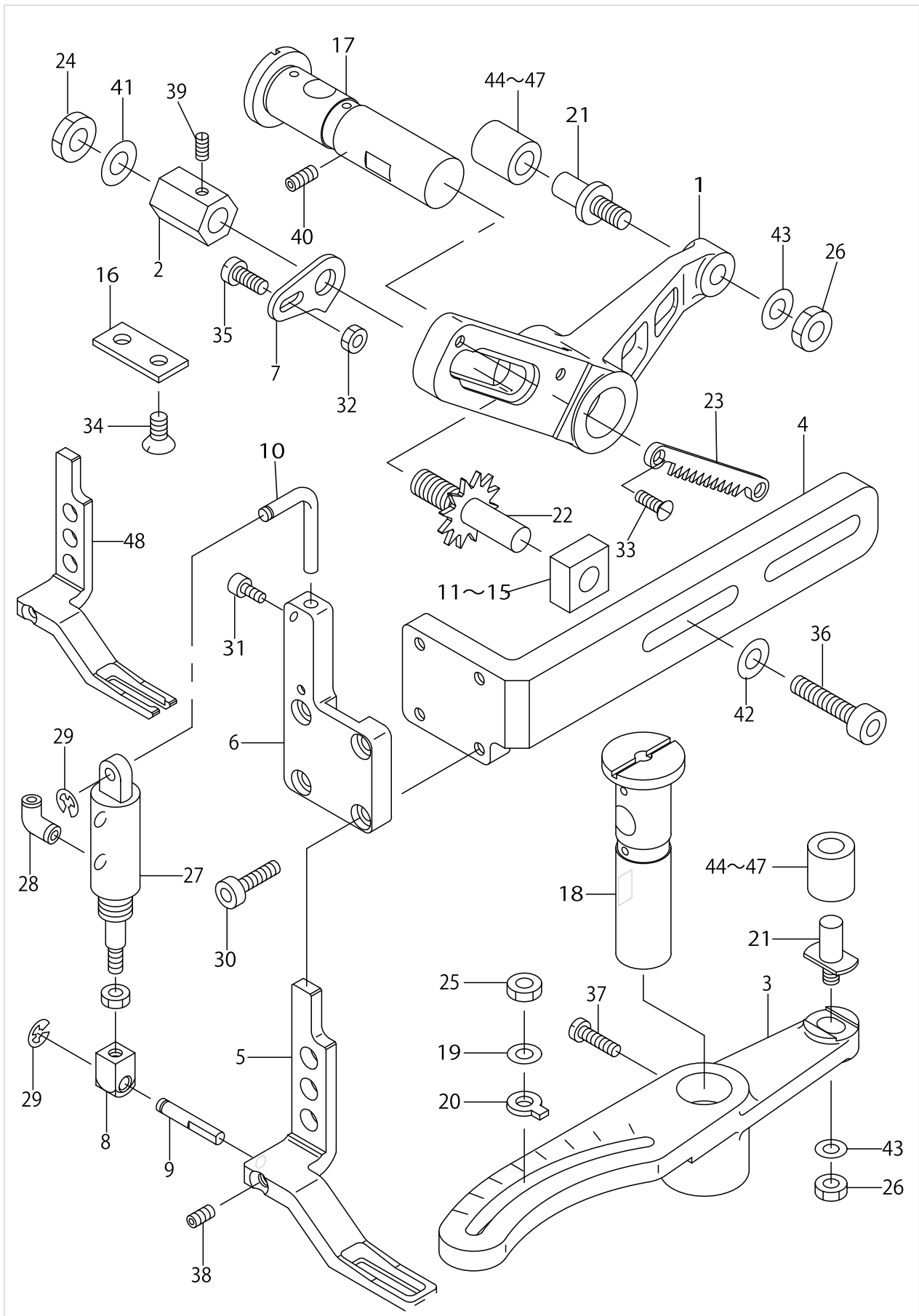

FEED MECHANISM COMPONENTS(2)

No.	Parts No.	Parts name	Remarks	Level	Cons	Qty
1	13879002	VERTICAL FEED ARM				1
2	13879101	VERTICAL FEED KNOB				1
3	13879507	CROSSFEED ARM				1
4	13877709	CLOTH PRESSER FOOT BASE				1
5	13875604	CLOTH PRESSER FOOT				1
6	13877907	CLOTH PRESSER BASE COVER				1
7	13880901	PLATE				1
8	13880604	WASHER				1
9	13880703	CYLINDER PIN				1
10	13880802	L-TYPE CYLINDER BASE				1
11	13516604	SLIDE BLOCK A	SELECTIVE PART			1
12	13516703	SLIDE BLOCK B	SELECTIVE PART			1
13	13516802	SLIDE BLOCK C	SELECTIVE PART			1
14	13519103	SLIDE BLOCK	SELECTIVE PART			1
15	13519202	SLIDE BLOCK	SELECTIVE PART			1
16	13518907	SUPPORT PLATE				1
17	13516208	FEED DRIVING ARM SHAFT				1
18	13516208	FEED DRIVING ARM SHAFT				1
19	WP0600116KP	WASHER				1
20	B1608774000	LENGTH REGULATING SHAFT GUIDE				1
21	B2501280000	FEED CAM ROLLER SHAFT				2
22	B2506980000	FEED REGULATOR PINION				1
23	B2508280000	FEED REGULATOR RACK				1
24	NS6150430SP	NUT 15/64-28				1
25	NS6150440SP	NUT 15/64-28				1
26	NS6660430SP	NUT 1/4-40				2
27	PA1002501A0	CYLINDER				1
28	PJ304040504	ELBOW UNION				2
29	RE0300000K0	E-RING 3				2
30	SM6041202TN	SCREW M4X0.7 L=12				4
31	SM6030860SP	SCREW				1
32	NS6090310SP	NUT 9/64-40				1
33	SS1090920SP	SCREW 9/64-40 L=9				2
34	SS1121010SP	SCREW				2
35	SS6090520SP	SCREW 9/64-40 L= 5.0				1
36	SS6152212SP	SCREW 15/64-28 L=22.0				2
37	SS6151220SP	SCREW 15/64-28 L=11.5				1
38	SS8110422TP	SCREW 11/64-40 L=4				1
39	SS8090710SP	SCREW 9/64-40 L= 7.0				1
40	SS8150822TP	SCREW 15/64-28 L=8				1
41	WP0612516SD	WASHER 6.1X15.2X2.5				1
42	WP0621016SH	WASHER				2
43	WP0650876SD	WASHER 6.5X13X0.8				2
44	B250228000A	FEED CAM ROLLER	SELECTIVE PART			2
45	B250228000B	FEED CAM ROLLER	SELECTIVE PART			2
46	B250228000C	FEED CAM ROLLER	SELECTIVE PART			2
47	B250228000D	CLOTH FEED CAM ROLLER	SELECTIVE PART			2

FEED MECHANISM COMPONENTS(2)

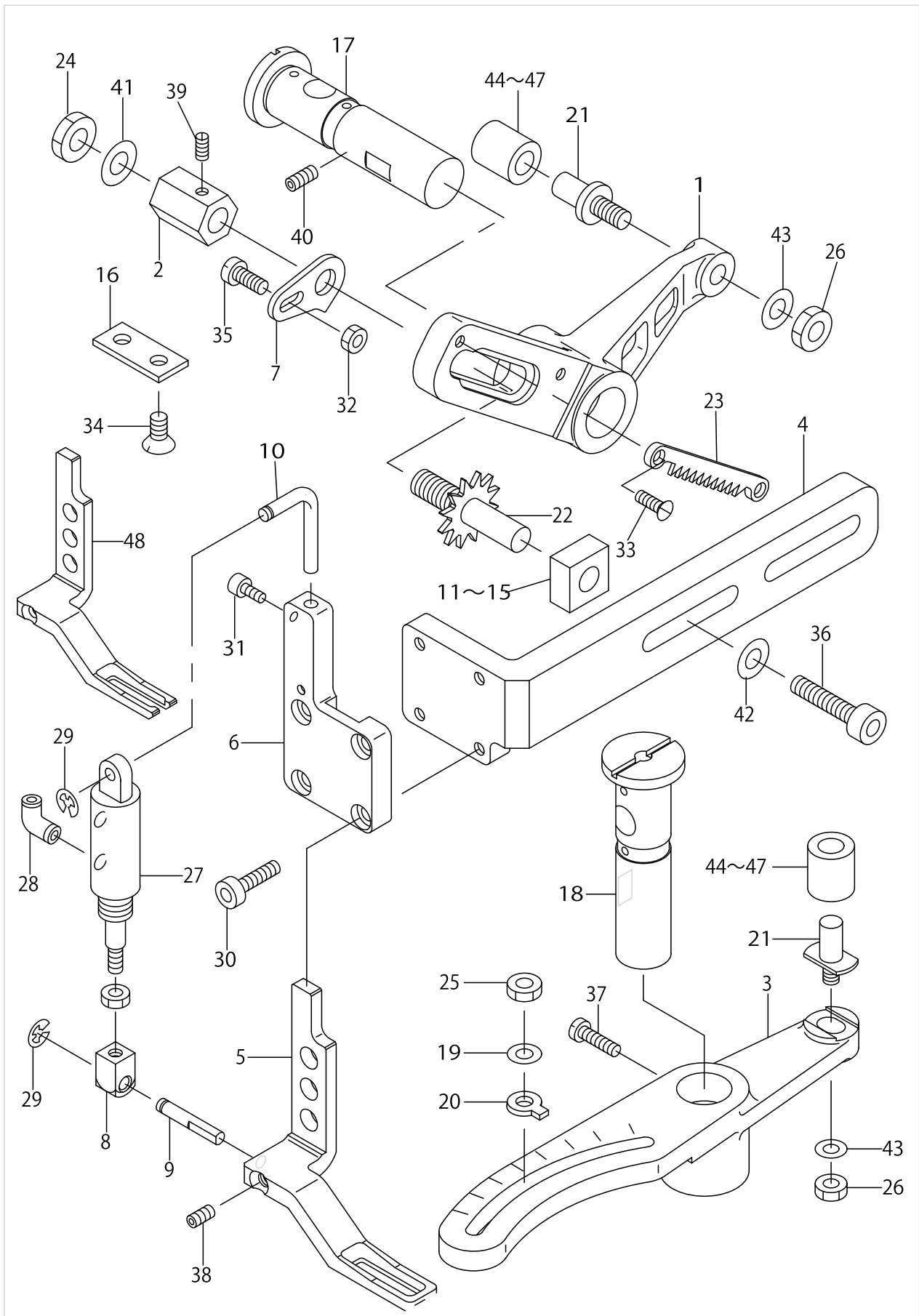

FEED MECHANISM COMPONENTS(2)

No.	Parts No.	Parts name	Remarks	Level	Cons	Qty
48	13877808	CLOTH PRESSER FOOT	FOR LK-195△F			1

THREAD TENSION COMPONENTS

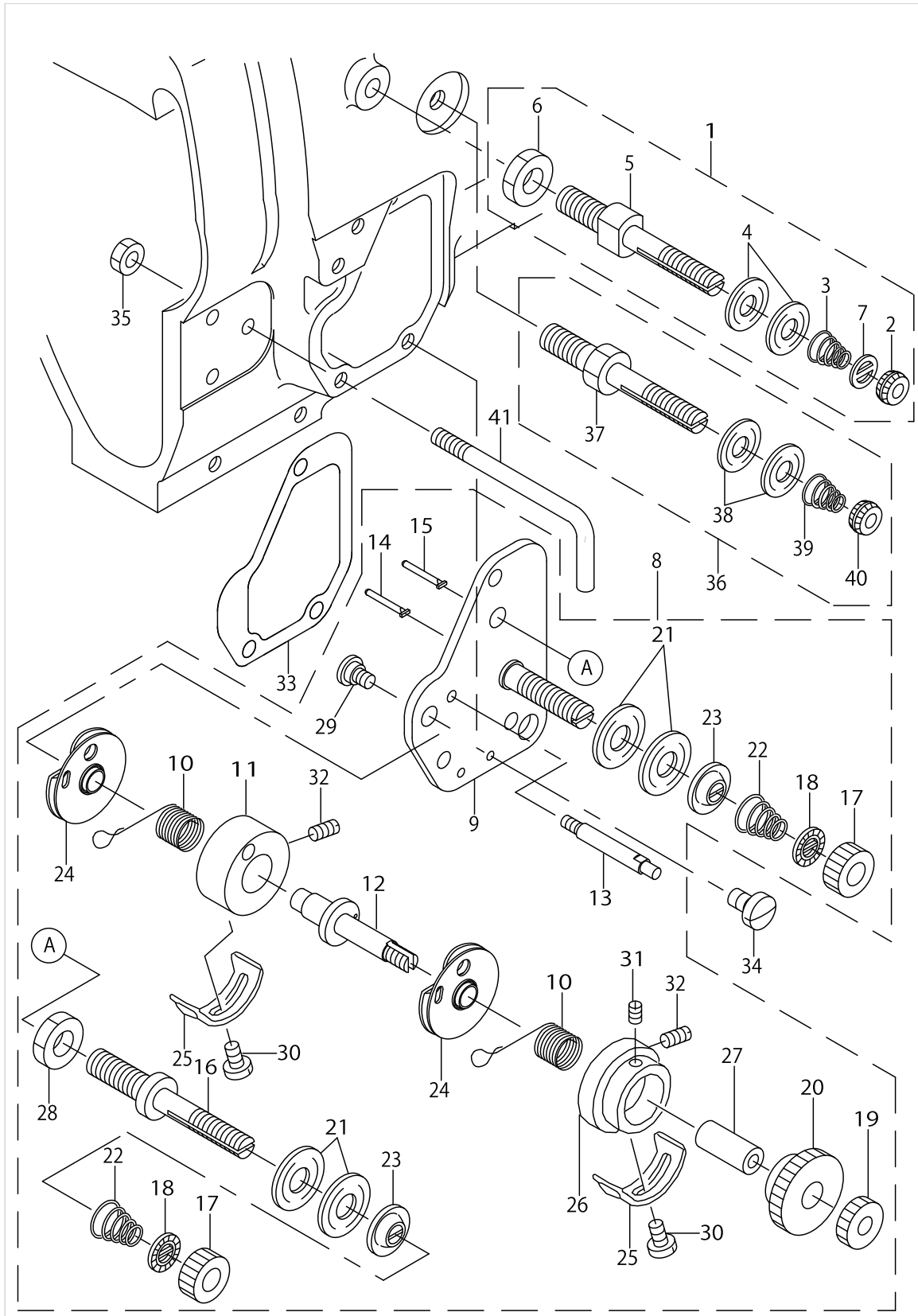

THREAD TENSION COMPONENTS

No.	Parts No.	Parts name	Remarks	Level	Cons	Qty
1	13883251	FIRST THREAD TENSION A ASM.				1
2	A3125002000	TENSION NUT, NO.1		*		1
3	B1115232000	FIRST THREAD TENSION SPRING		*		1
4	B3126012000	THREAD TENSION DISK		*		2
5	B3928880000	THREAD SPREADER TENSION		*		1
6	NS6150310SP	NUT 15/64-28		*		1
7	13874102	FIRST THREAD TENSION WASHER		*		1
8	13883368	THREAD TENSION PLATE JUNCTION				1
9	13883350	THREAD TENSION PLATE ASM.		*		1
10	13883004	THREAD TAKE-UP SPRING		*		2
11	13883103	THREAD TAKE-UP SPRING BASE, B		*		1
12	13883509	THREAD TAKE-UP SPRING SHAFT		*		1
13	13883608	SPRING BASE SHAFT		*		1
14	13884002	PIN, B		*		1
15	13760707	PIN		*		1
16	B2019372000	TENSION POST NO.2		*		1
17	B3116125000	TENSION NUT		*		2
18	B3120125000	ROTATING STOPPER		*		2
19	B3125012000	THREAD TENSION NUT		*		1
20	B3125527000	TAKE-UP SPRING GUIDE		*		1
21	B3126012000	THREAD TENSION DISK		*		4
22	B3114232000	THREAD TENSION SPRING		*		2
23	B3132552000	THREAD TENSION DISK PRESSER		*		2
24	13890454	SPRING GUIDE ASM.		*		2
25	B3138527000	ADJUSTING PLATE B		*		2
26	B3140527000	THREAD TENSION POST		*		1
27	B3141527000	PRESSER COLLAR		*		1
28	NS6160520SP	NUT 1/4-24		*		1
29	SD0640241SP	HINGE SCREW D= 6.35 H= 2.4		*		1
30	SS7090520SP	SCREW 9/64-40 L= 4.5		*		2
31	SS8080410TP	SCREW 1/8-44 L=3.5		*		1
32	SS8080610SP	SCREW 1/8-44 L=5.5		*		2
33	13883400	PACKING				1
34	SS6120940SP	SCREW 3/16-28 L=9				3
35	NS6120310SP	NUT 3/16-28				1
36	B11152320A0	FIRST THREAD TENSION ASM.				1
37	B3123352000	THREAD TENSION ROD		*		1
38	B3126012000	THREAD TENSION DISK		*		2
39	B1115232000	FIRST THREAD TENSION SPRING		*		1
40	A3125002000	TENSION NUT, NO.1		*		1
41	13883905	L-TYPE THREAD GUIDE				1

THREAD TRIMMER COMPONENTS

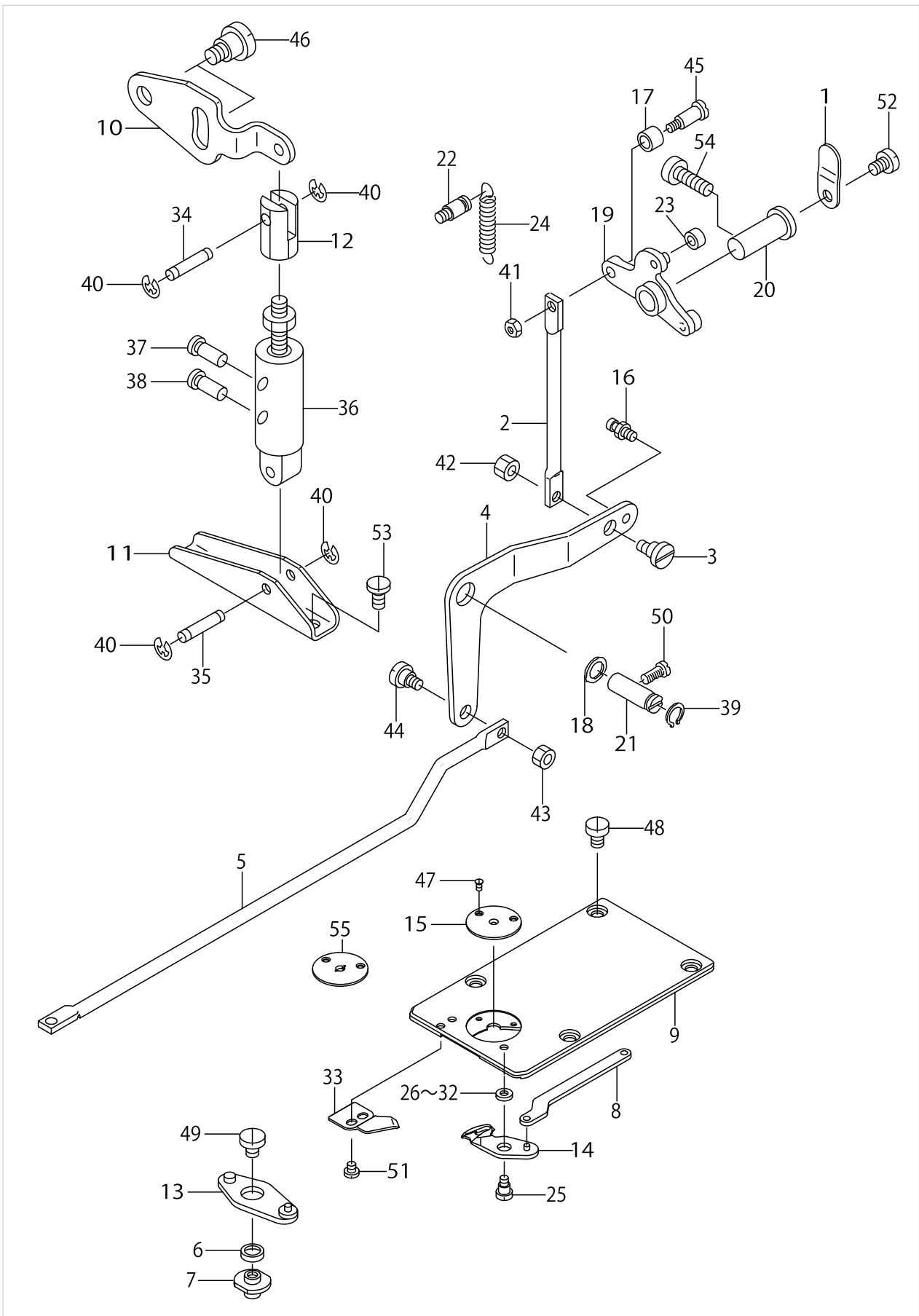

THREAD TRIMMER COMPONENTS

No.	Parts No.	Parts name	Remarks	Level	Cons	Qty
1	13881404	CAM LOLLER COVER				1
2	13881503	CONNECTION BAR, SMAL				1
3	13881602	ADJUSTING SCREW				1
4	13881701	THREAD CUTTING LINK				1
5	13881800	CONNECTION BAR, LARGE				1
6	13881909	THREAD CUTTING LINK ROLLER				1
7	13882006	THREAD CUTTING LEVER SHAFT				1
8	13882105	MOVING KNIFE LINK				1
9	13882204	NEEDLE PLATE				1
10	13882303	AUXILIARY LEVER				1
11	13882402	CYLINDER FITTING PLATE				1
12	13881305	CYLINDER KNUCKLE				1
13	13882659	THREAD CUTTING LEVER JUNCTION				1
14	13881255	MOVING KNIFE JUNCTION				1
15	13882501	NEEDLE HOLE GUIDE				1
16	10120004	SPRING SUSPENSION				1
17	13514310	ROLLER				1
18	13515309	THREAD CUTTING RING				1
19	13534060	THREAD CUTTING CAM COMPL.				1
20	13807904	THREAD TRIMMER ARM SHAFT				1
21	13515101	THREAD CUTTING LINK SHAFT				1
22	B1631012B00	SUSPENSION STUD B				1
23	B2404280000	THREAD CUTTING CAM ROLLER				1
24	B2410980000	TENSION SPRING				1
25	B2417210000	MOVING KNIFE HINGE SCREW				1
26	B242328000A	MOVING KNIFE WASHER A	SELECTIVE PART			1
27	B242328000B	MOVING KNIFE WASHER B	SELECTIVE PART			1
28	B242328000C	MOVING KNIFE WASHER C	SELECTIVE PART			1
29	B242328000D	MOVING KNIFE WASHER D	SELECTIVE PART			1
30	B242328000E	MOVING KNIFE WASHER E	SELECTIVE PART			1
31	B242328000F	MOVING KNIFE WASHER F	SELECTIVE PART			1
32	B242328000G	MOVING KNIFE WASHER G	SELECTIVE PART			1
33	B2424210000	COUNTER KNIFE				1
34	D2464555B00	LINK DRIVING MAGNET PIN				1
35	GAK33012000	SOLENOID PIN				1
36	PA2001501A0	AIR CYLINDER				1
37	PJ301060501	UNION				1
38	PJ301065104	HALF UNION				1
39	RC1021011KP	RETAINING RING 10.2				1
40	RE0400000KP	E-RING 4				4
41	NS6120310SP	NUT 3/16-28				1
42	NS6120310SP	NUT 3/16-28				1
43	NS6120310SP	NUT 3/16-28				1
44	SD0650305TP	HINGE SCREW D= 6.5 H= 3				1
45	SD0651301TH	HINGE SCREW D=6.5 H=13				1
46	SD0901201TP	HINGE SCREW D=9 H=3.2				2
47	SS1060210TP	SCREW 3/32-56 L=2.2				2

THREAD TRIMMER COMPONENTS

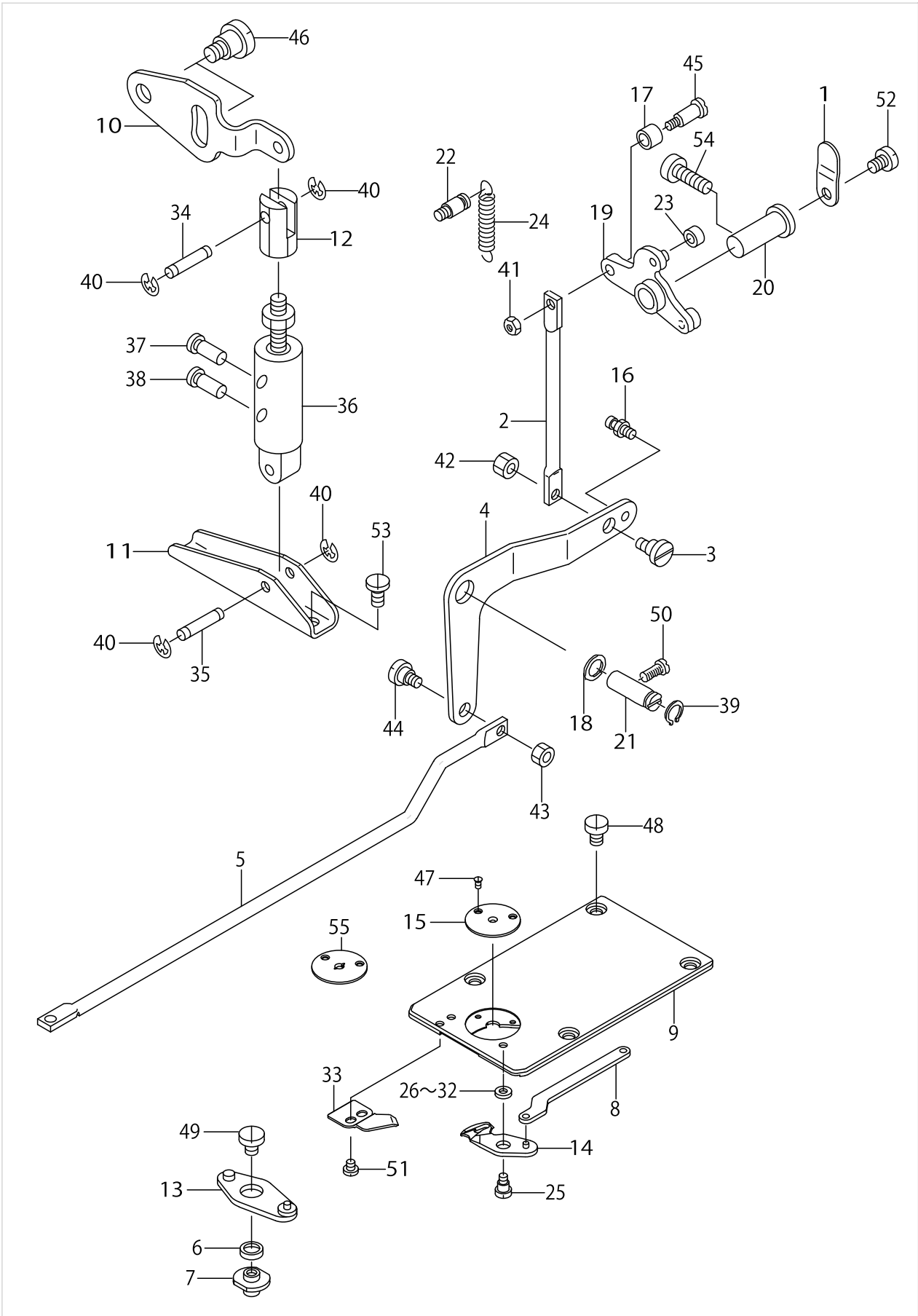

THREAD TRIMMER COMPONENTS

No.	Parts No.	Parts name	Remarks	Level	Cons	Qty
48	SS6110610TP	SCREW 11/64-40 L=6				4
49	SS6110640SP	SCREW 11/64-40 L=6				1
50	SS6151440SP	SCREW 15/64-28 L=14				1
51	SS7090410SP	SCREW 9/64-40 L= 3.5				2
52	SS7120710SP	SCREW 3/16-28 L=7				1
53	SS7150910TP	SCREW 15/64-28 L=9				2
54	SS6151920TP	SCREW 15/64-28 L=19.0				1
55	13884309	NEEDLE HOLE GUIDE 2.6	SPECIAL ORDER PART			1

THREAD PRESSER COMPONENTS

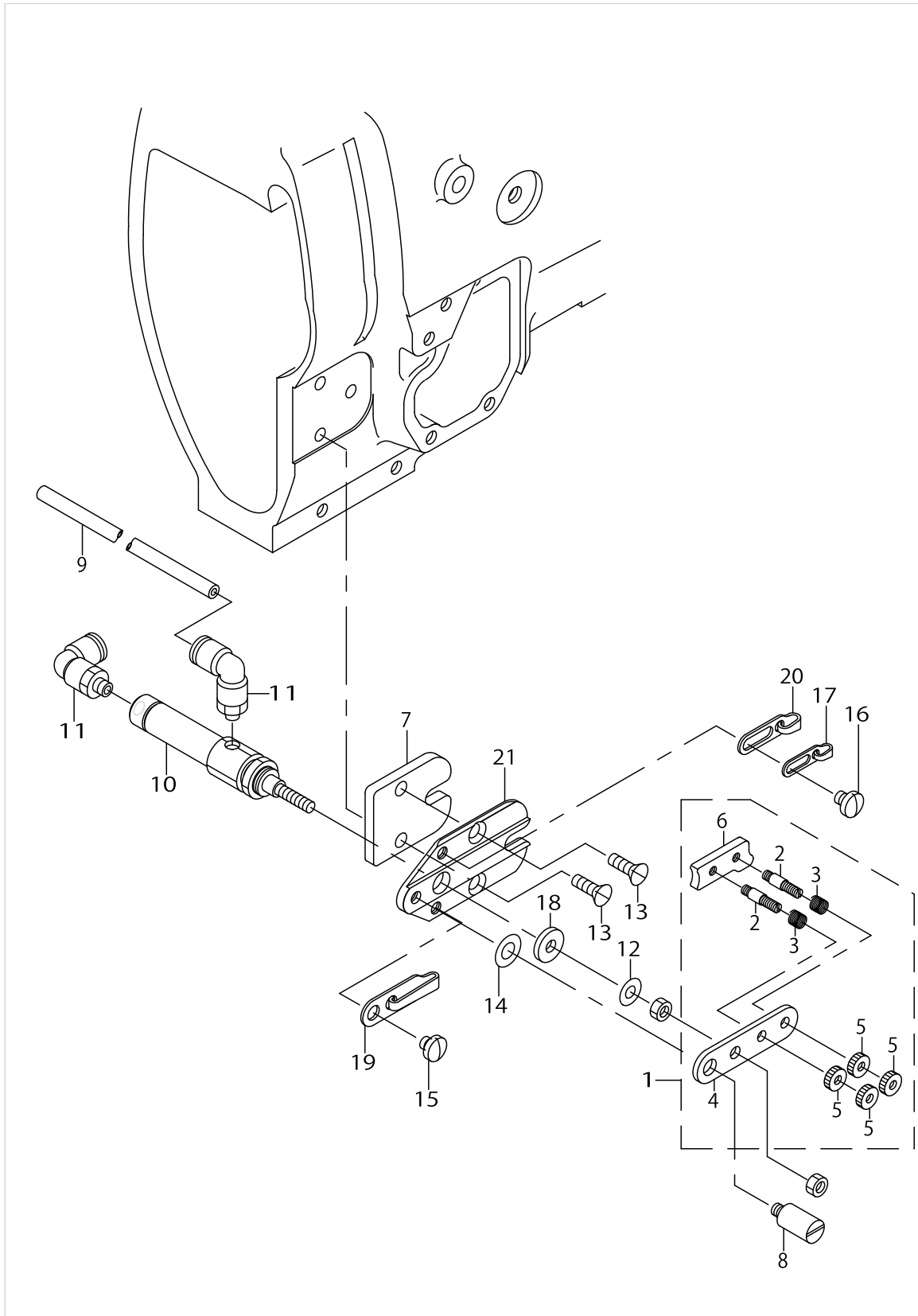

THREAD PRESSER COMPONENTS

No.	Parts No.	Parts name	Remarks	Level	Cons	Qty
1	13883756	THREAD PRESSER PLATE COMPL.				1
2	25002809	THREAD TENSION STUD		*		2
3	B1136850000	TENSION SPRING B		*		2
4	13884218	THREAD PRESSER PLATE LINK		*		1
5	25002908	THREAD TENSION NUT		*		4
6	13883715	THREAD PRESSER PLATE		*		1
7	13883806	FITTING PLATE SPACER				1
8	16201501	ROLLER PRESSURE SHAFT				1
9	BT0400251ED	TUBE HOSE, GREEN				0.9
10	PA1001022A0	AIR CYLINDER				1
11	PJ304040504	ELBOW UNION				2
12	WP0450801SD	WASHER 4.5X10X0.8				1
13	SS1121010SP	SCREW				2
14	WP0482086SD	WASHER 4.8X11.5X2				1
15	SS7110410SP	SCREW 11/64-40 L=4				1
16	SS7110510SP	SCREW 11/64-40 L=5				1
17	13922208	TAKE-UP THREAD GUIDE B				1
18	B1144771000	FRAME SIDE COVER GASKET (C)				1
19	13871108	BALANCE THREAD GUIDE, B				1
20	13870902	BALANCE THREAD GUIDE, C				1
21	13884119	THREAD PRESSER FITTING PLATE				1

BOBBIN WINDER COMPONENTS

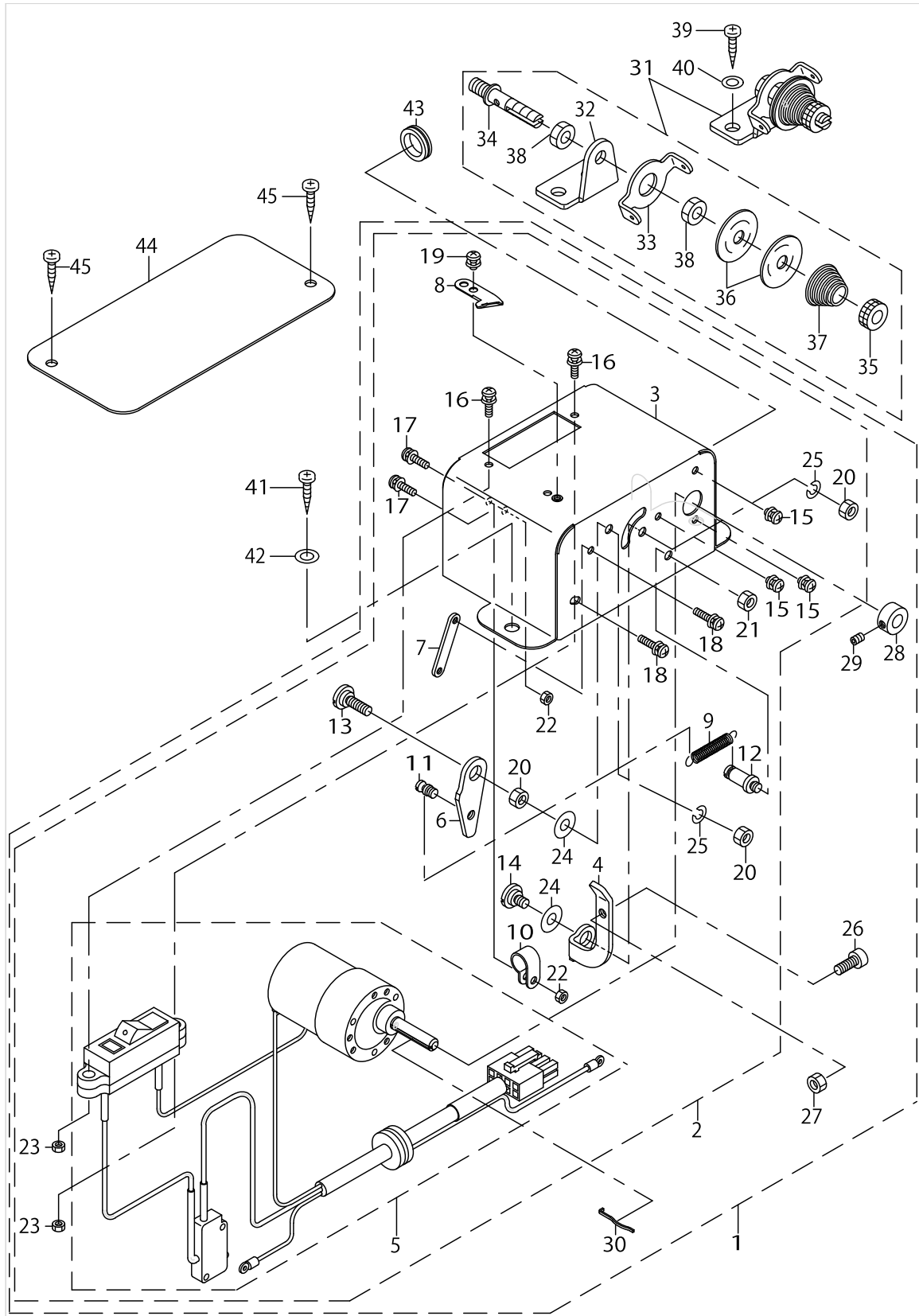

BOBBIN WINDER COMPONENTS

No.	Parts No.	Parts name	Remarks	Level	Cons	Qty
1	13870266	BOBBIN THREAD WINDING DEVICE				1
2	13870258	BOBBIN THREAD WIDING DEVICE		*		1
3	13870209	BOBBIN THREAD COVER		*		1
4	13870605	BOBBIN GUIDE		*		1
5	13874052	MOTOR ASM.		*		1
6	13889704	SWITCH PUSHING PLATE		*		1
7	11102308	MICRO SWITCH PLATE		*		1
8	10502300	THREAD CUTTER		*		1
9	B3041980000	SPRING		*		1
10	HX001230000	CABLE CLIP		*		1
11	B1110280000	THREAD CUTTING LINK SPRING RAC		*		1
12	B3413227000	SPRING SUSPENSION		*		1
13	SD0720222TP	HINGE SCREW D=7.24 H=2.2		*		1
14	SD0720221SP	HINGE SCREW D= 7.24 H= 2.2		*		1
15	SL4030591SC	SCREW M3X5		*		3
16	SL4031281SC	SCREW M3 L=12		*		2
17	SL4031281SC	SCREW M3 L=12		*		2
18	SL4031481SC	SCREW M3 X 14		*		2
19	SL4030591SC	SCREW M3X5		*		1
20	NS6110420SP	NUT 11/64-40		*		3
21	NS6110420SP	NUT 11/64-40		*		1
22	NM6030001SC	NUT M3		*		2
23	NM6030001SC	NUT M3		*		2
24	WP0551016SH	WASHER 5.5X13X1		*		2
25	WS0451040KP	SPRING WASHER 4.5X8.5X1		*		2
26	B3208280000	BOBBIN WINDER ADJUSTING SCREW		*		1
27	NS6110420SP	NUT 11/64-40		*		1
28	CS0640611SP	THRUST HOLDER		*		1
29	SS8090530TP	SCREW 9/64-40 L= 5.0		*		1
30	B3212761000	LATCH SPRING		*		1
31	13889951	BOBBIN GUIDE ASM.				1
32	B2612372000	STOP MOTION TRIP LEVER BRACKET		*		1
33	B3107352000	NEEDLE THREAD GUIDE		*		1
34	B3108352000	NEEDLE THREAD TENSION POST		*		1
35	B3125012000	THREAD TENSION NUT		*		1
36	B3126012000	THREAD TENSION DISK		*		2
37	B3129771000	TENSION SPRING		*		1
38	NS6150430SN	NUT 15/64-28		*		2
39	SK3412001SC	WOOD SCREW D=4.1 L=20				2
40	WP0501016SC	WASHER 5X10.5X1				2
41	SK3412001SC	WOOD SCREW D=4.1 L=20				2
42	WP0501016SC	WASHER 5X10.5X1				2
43	HX00221000C	BUSH				1
44	13890504	SPACER	SPECIAL ORDER PART			1
45	SK3412001SC	WOOD SCREW D=4.1 L=20				2

HOOK BASE COMPONENTS(1)

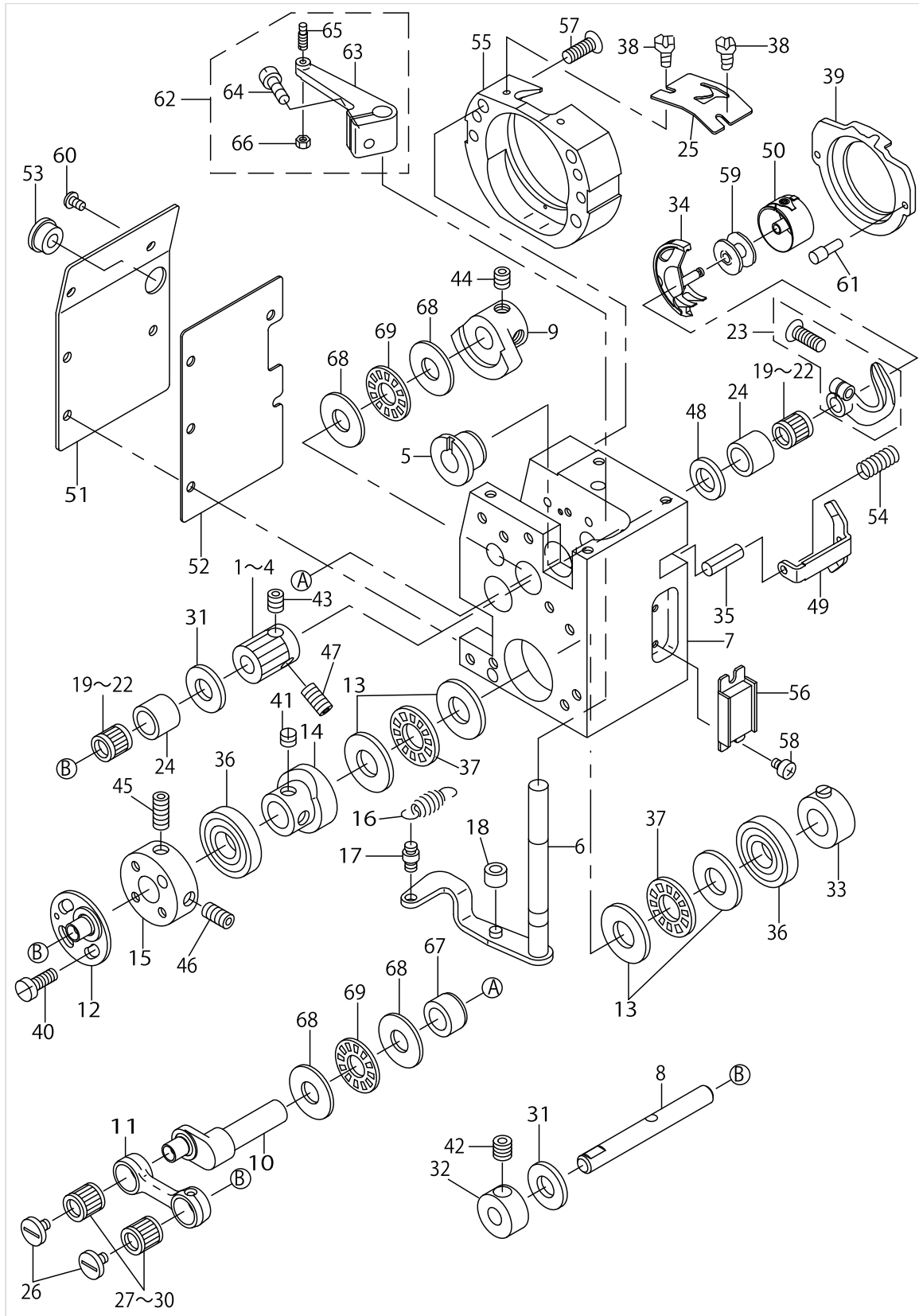

HOOK BASE COMPONENTS(1)

No.	Parts No.	Parts name	Remarks	Level	Cons	Qty
1	13877303	LOWER SHAFT WHEEL, A	SELECTIVE PART			1
2	13877402	LOWER SHAFT WHEEL, B	SELECTIVE PART			1
3	13877501	LOWER SHAFT WHEEL, C	SELECTIVE PART			1
4	13877600	LOWER SHAFT WHEEL, D	SELECTIVE PART			1
5	13885306	METAL				1
6	13885454	THREAD CUTTING LEVER ASM.				1
7	13885801	HOOK BASE				1
8	13885900	LOWER SHAFT, B				1
9	13886015	CRANK WHEEL				1
10	13886411	CRANK				1
11	13886502	CRANK ROD				1
12	13886601	REMOVING SHAFT CRANK				1
13	13887005	THRUST WASHER				4
14	13887104	THREAD CUTTING CAM, B				1
15	13887203	REMOVING SHAFT CRANK BASE				1
16	13888201	SPRING				1
17	10527208	HINGE SCREW				1
18	11041100	ROLLER				1
19	B1411804A00	BEARING (A)	SELECTIVE PART			2
20	B1411804B00	NEEDLE DRIVING LEVER BEARING B	SELECTIVE PART			2
21	B1411804C00	NEEDLE DRIVING LEVER BEARING C	SELECTIVE PART			2
22	B1411804D00	BEARING (D)	SELECTIVE PART			2
23	B18122100A0	DRIVER ASM.				1
24	B1813980000	SHUTTLE NEEDLE OUTER RING				2
25	B1815210000	INNER HOOK UPPER SPRING				1
26	B1903552000	LEFT SCREW				2
27	B1905541A00	NEEDLE BEARING, A	SELECTIVE PART			2
28	B1905541B00	NEEDLE BEARING	SELECTIVE PART			2
29	B1905541C00	NEEDLE BEARING	SELECTIVE PART			2
30	B1905541D00	NEEDLE BEARING	SELECTIVE PART			2
31	D1807555B00	THRUST COLLAR				2
32	CS0801011TH	THRUST COLLAR D=8 W=10				1
33	CS1201010SH	THRUST COLLAR ASM. D=12 W=10				1
34	13876305	INNER HOOK				1
35	PS0250162KH	SPRING PIN 2.5X16				2
36	SB112000200	BEARING				2
37	SB612000100	BEARING				2
38	SS6060410TP	SCREW 3/32-56 L= 3.5				2
39	13876602	INNER HOOK PRESSER				1
40	SS7111120TP	SCREW				3
41	SS8660330SP	SCREW 1/4-40 L= 3.0				2
42	SS8660522TP	SCREW 1/4-40 L=4.5				2
43	SS8660612TP	SCREW 1/4-40 L=6				1
44	SS8660612TP	SCREW 1/4-40 L=6				2
45	SS8661012TP	SCREW				1
46	SS8661212TP	SCREW				1
47	SS8661212TP	SCREW				1

HOOK BASE COMPONENTS(1)

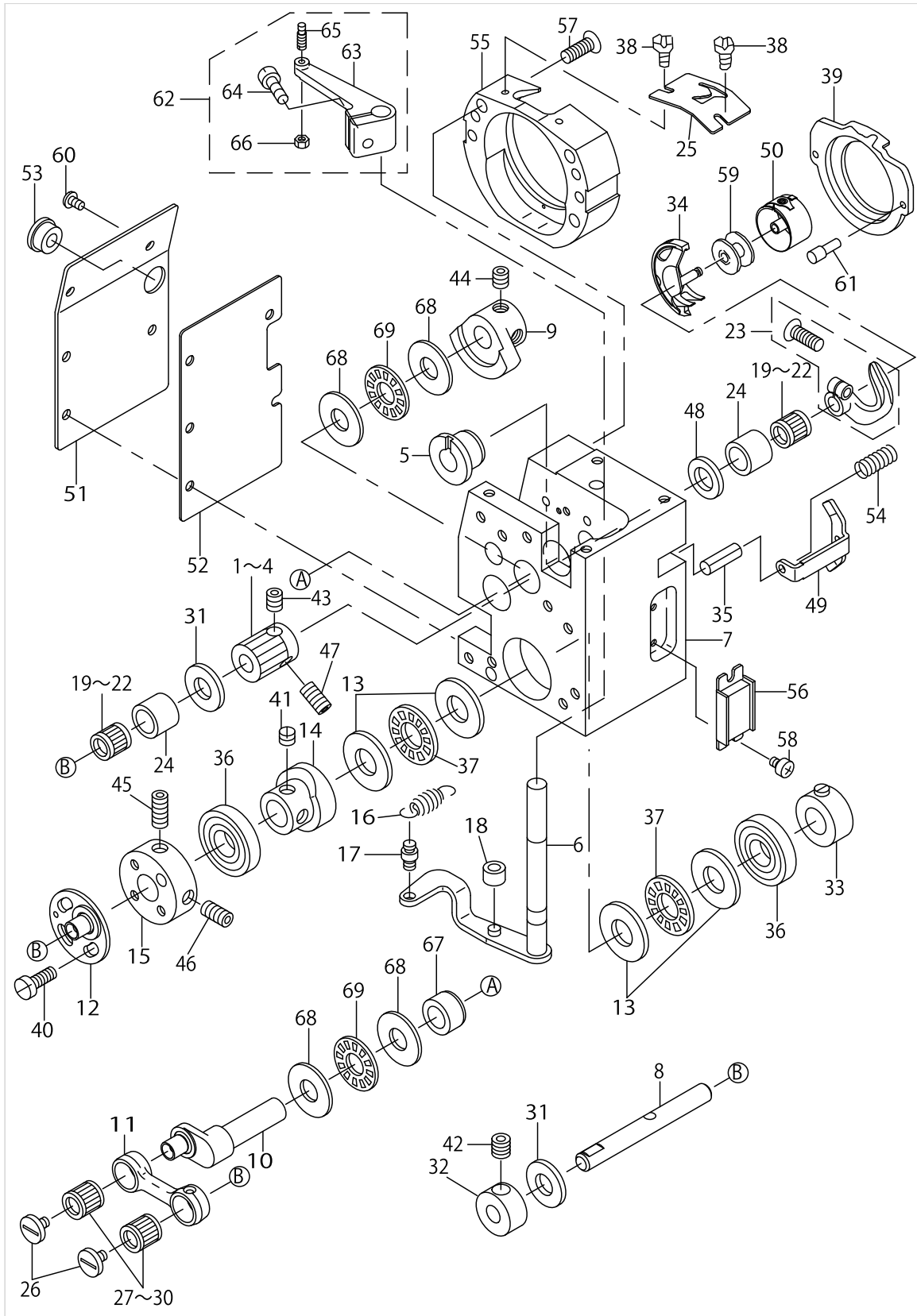

HOOK BASE COMPONENTS(1)

No.	Parts No.	Parts name	Remarks	Level	Cons	Qty
48	WP0952616SD	WASHER 9.5X14.8X2.6				1
49	13876719	INNER HOOK PRESSER HOOK				2
50	B18282100A0	BOBBIN CASE ASM.				1
51	13887906	HOOK BASE COVER, LEFT				1
52	13886205	PACKING				1
53	TA1250406R0	RUBBER PLUG D=12.5 L=4				1
54	16189508	ADJUSTING SPRING				2
55	13885603	SHUTTLE, B				1
56	13886106	HOOK COVER MAGNET, A				1
57	SS2111140SP	SCREW 11/64-40 L=11				3
58	SM4030455SN	SCREW				2
59	B1805210A00	BOBBIN				1
60	SS5090610SP	SCREW 9/64-40 L=6				5
61	B1816280000	GUIDE PIN				2
62	13887450	THREAD CUTTING ARM ASM.				1
63	13887401	THREAD CUTTING ARM		*		1
64	SS7111120TP	SCREW		*		1
65	13874300	THREAD CUTTING ARM PIN		*		1
66	NS6090310SP	NUT 9/64-40		*		1
67	13879606	HOOK CRANK METAL B				1
68	16992604	THRUST WASHER				4
69	11272408	THRUST COLLAR				2

HOOK BASE COMPONENTS(2)

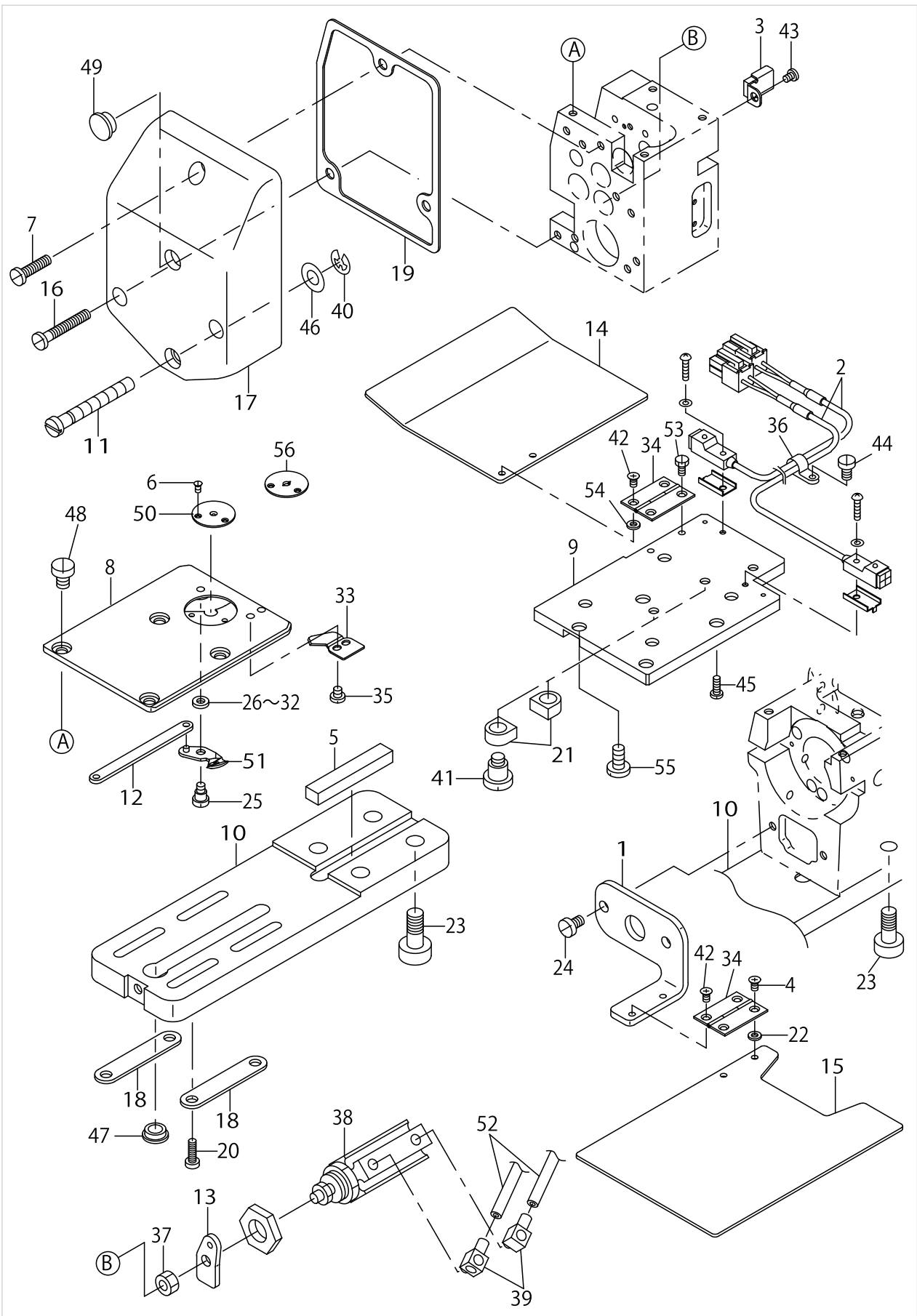

HOOK BASE COMPONENTS(2)

No.	Parts No.	Parts name	Remarks	Level	Cons	Qty
1	13872403	BED FACE COVER				1
2	13873450	HOOK COVER SENSOR ASM.				2
3	13885256	HOOK COVER MAGNET ASM., B				1
4	SM4030455SN	SCREW				2
5	13885702	KEY				1
6	SS1060210TP	SCREW 3/32-56 L=2.2				2
7	SS6121840SP	SCREW 3/16-28 L=18				1
8	13886304	THROAT PLATE, B				1
9	13886700	HOOK CONNECTING PLATE				1
10	13886809	HOOK SUPPORT BASE				1
11	13886908	ADJUSTING SHAFT				1
12	13887302	MOVING KNIFE LINK, B				1
13	13887500	SPRING RACK				1
14	13887708	HOOK COVER, LEFT				1
15	13887807	HOOK COVER, RIGHT				1
16	SS6123010SP	SCREW 3/16-28 L=30.0				2
17	13888003	HOOK BASE COVER				1
18	13888102	WASHER				2
19	13888805	PACKING				1
20	SS6151412TP	SCREW 15/64-28 L=14				4
21	B1414226000	SLIDE BLOCK				2
22	B1623180000	WASHER				2
23	SS6242272TP	SCREW 3/8-18 L=22.0				4
24	SS6121010SP	SCREW 3/16-28 L=10				2
25	B2417210000	MOVING KNIFE HINGE SCREW				1
26	B242328000A	MOVING KNIFE WASHER A	SELECTIVE PART			1
27	B242328000B	MOVING KNIFE WASHER B	SELECTIVE PART			1
28	B242328000C	MOVING KNIFE WASHER C	SELECTIVE PART			1
29	B242328000D	MOVING KNIFE WASHER D	SELECTIVE PART			1
30	B242328000E	MOVING KNIFE WASHER E	SELECTIVE PART			1
31	B242328000F	MOVING KNIFE WASHER F	SELECTIVE PART			1
32	B242328000G	MOVING KNIFE WASHER G	SELECTIVE PART			1
33	B2424210000	COUNTER KNIFE				1
34	B2597210000	CASSETTE HOLDER HINGE				2
35	SS7090410SP	SCREW 9/64-40 L= 3.5				2
36	HX00150000A	CABLE CLAMP				1
37	NM6050001SP	NUT M5				1
38	PA1501515A0	AIR CYLINDER				1
39	PJ046054002	HOSE ELBOW				2
40	RE0400000K0	E-RING 4				1
41	SD0640752TP	HINGE SCREW D= 6.35 H= 7.5				2
42	SM1030401SE	SCREW M3 L=4				4
43	SS6111052TP	SCREW				1
44	SS7110710SP	SCREW 11/64-40 L=7				1
45	SS7150910TP	SCREW 15/64-28 L=9				3
46	WP0621016SH	WASHER				1
47	TA1330405R0	BUSHING				1

HOOK BASE COMPONENTS(2)

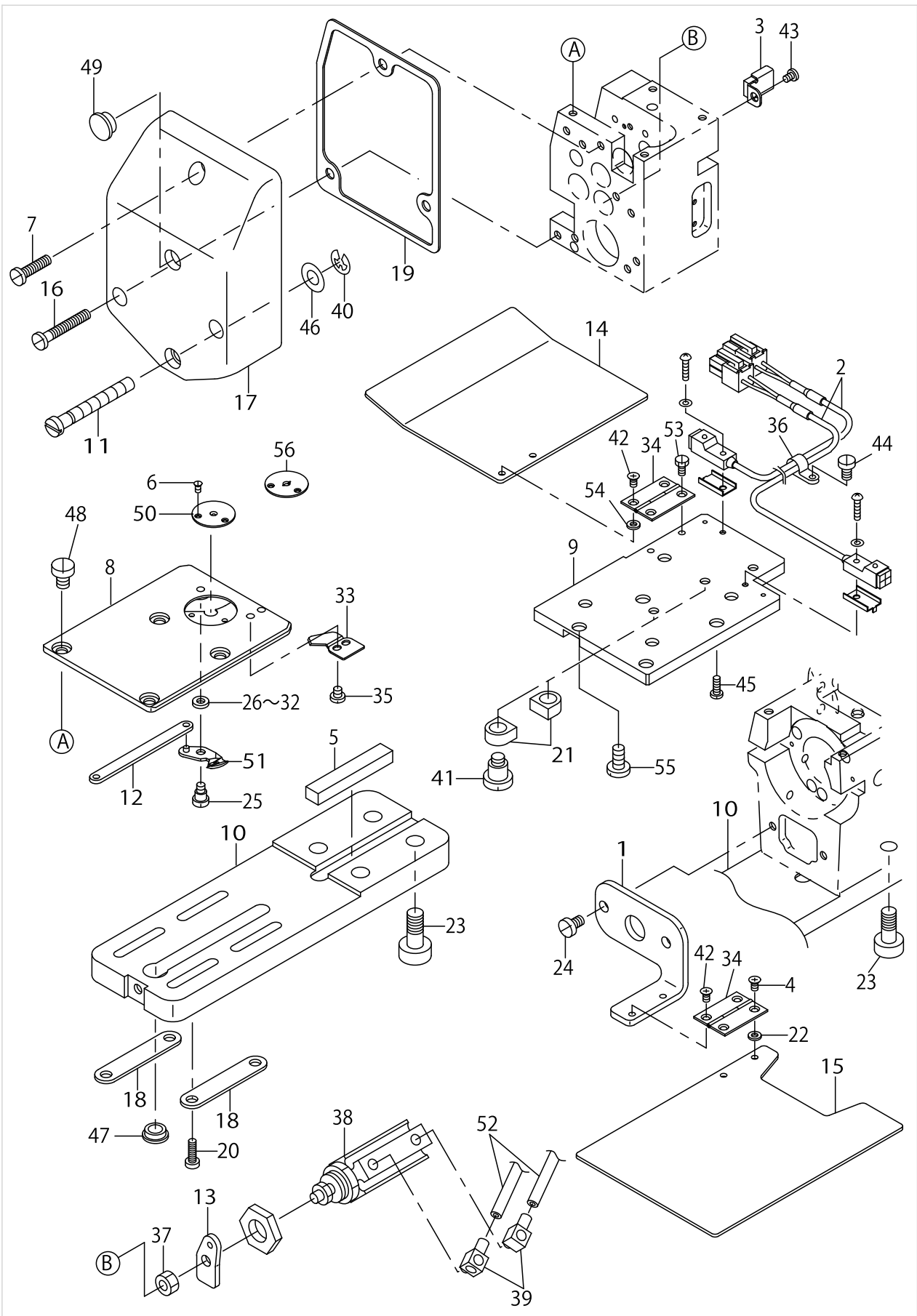

HOOK BASE COMPONENTS(2)

No.	Parts No.	Parts name	Remarks	Level	Cons	Qty
48	SS6110610TP	SCREW 11/64-40 L=6				4
49	TA1050504R0	RUBBER PLUG				1
50	13882501	NEEDLE HOLE GUIDE				1
51	13881255	MOVING KNIFE JUNCTION				1
52	BT0600401EF	TUBE				1.17
53	SM9030650SN	SCREW				2
54	WP0371026SD	WASHER 3.7X7X1				2
55	SS7150940SP	SCREW 15/64-28 L=9				1
56	13884309	NEEDLE HOLE GUIDE 2.6	SPECIAL ORDER PART			1

DISH RISING COMPONENTS

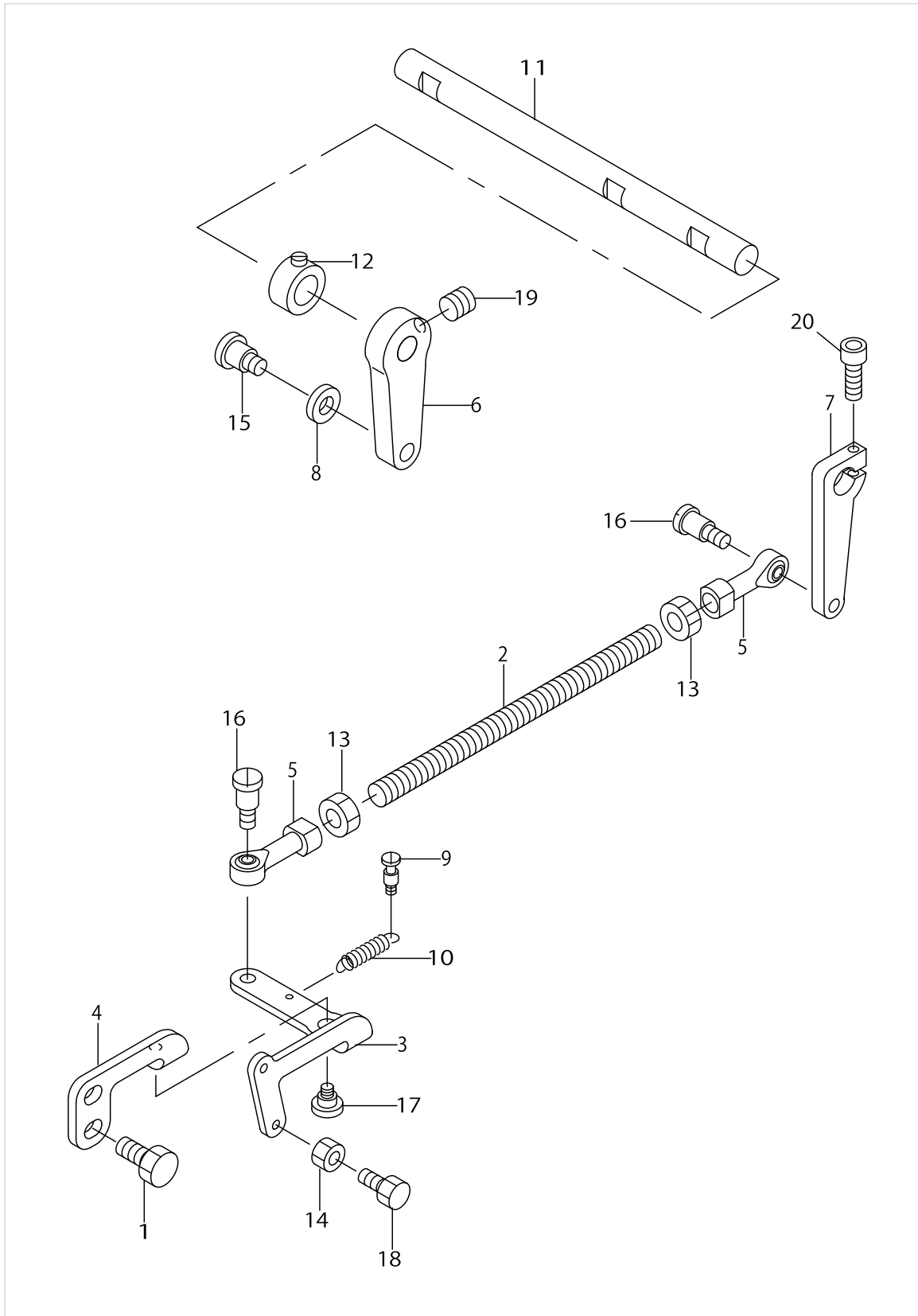

DISH RISING COMPONENTS

No.	Parts No.	Parts name	Remarks	Level	Cons	Qty
1	SS9120910TP	SCREW 3/16-28 L=9				2
2	13884507	JOINT SHAFT				1
3	13884606	LINK				1
4	13884705	DISH RISING LINK BASE				1
5	10064400	BALL JOINT B				2
6	11274107	UPPER FEED LEVER SHAFT ARM				1
7	13513114	TENSION RELEASE ARM				1
8	13722509	DRIVING SAFETY ROLLER				1
9	B1631012B00	SUSPENSION STUD B				1
10	D2629M1YC0F	SPRING				1
11	GBR01525000	OUTPUT AXIS				1
12	CS100101BSH	THRUST COLLAR ASM.				1
13	NM6060001SC	NUT M6				2
14	NS6090310SP	NUT 9/64-40				2
15	SD0600411TP	HINGE SCREW H=6 W=4.1				1
16	SD0601021SP	HINGE SCREW D=6 H=10.2				2
17	SD0550271TP	HINGE SCREW D= 5.50 H= 2.7				1
18	SS9090813TP	SCREW 9/64-40 L=8				2
19	SS8660612TP	SCREW 1/4-40 L=6				1
20	SM6061802TP	SCREW M6 L=18				1

SAFETY COMPONENTS

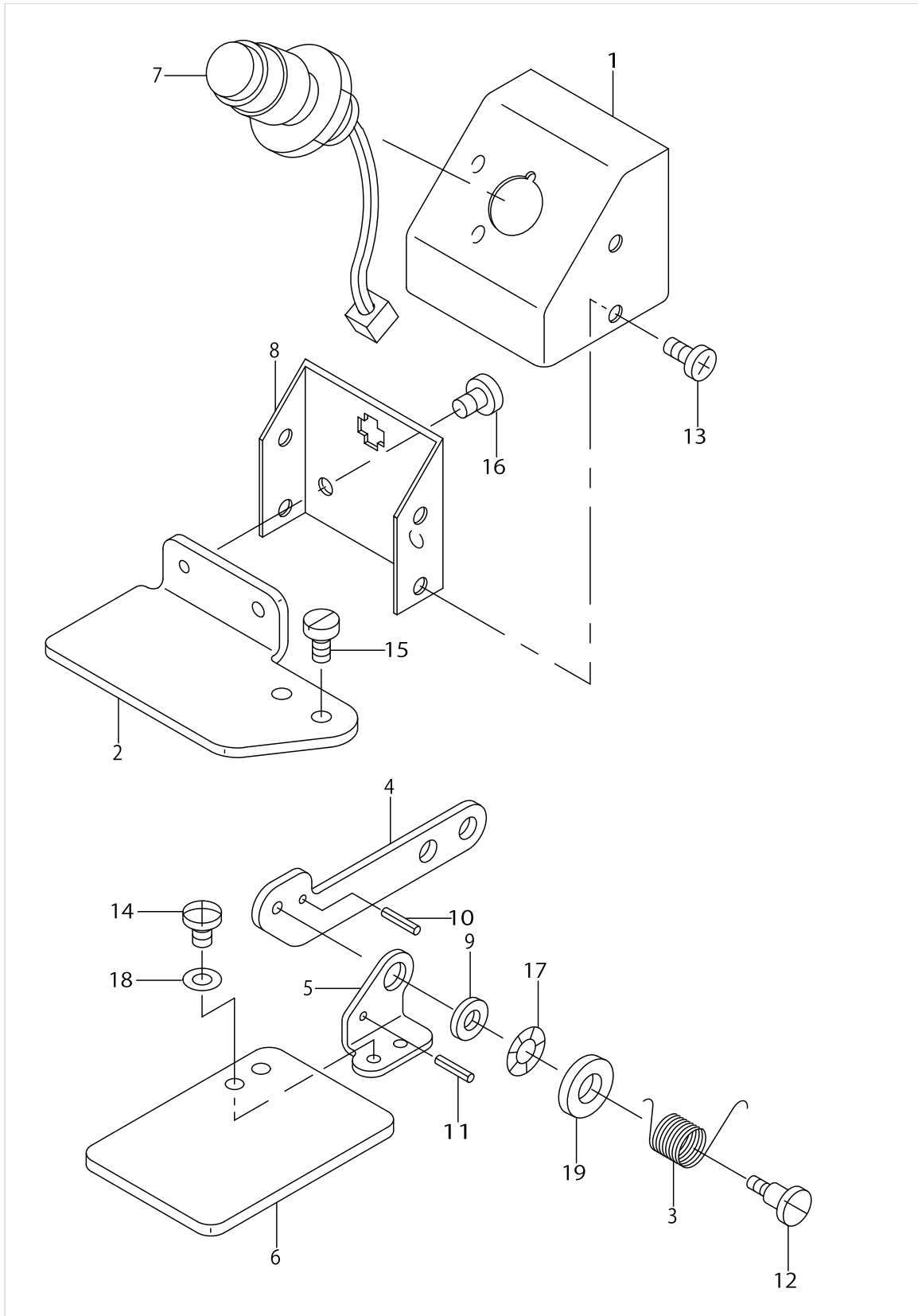

SAFETY COMPONENTS

No.	Parts No.	Parts name	Remarks	Level	Cons	Qty
1	13889100	SWITCH COVER				1
2	13889209	EMERGENCY STOP FITTING PLATE				1
3	13874409	SPRING				1
4	13889001	SAFETY PLATE MOUNTING BASE				1
5	13889308	SAFETY PLATE MOUNTING PLATE				1
6	13889407	SAFETY PLATE				1
7	13874250	ONE TIME STOPPAGE SW ASM.				1
8	17834706	SWITCH PLATE, LOWER				1
9	B3013141H0A	WASHER				1
10	PS0250202KH	SPRING PIN 2.5X20				1
11	PS0250081K0	SPRING PIN 2.5X8				1
12	SD0640851SP	STEP-SCREW				1
13	SM5040601SC	SCREW M4X0.7 L=6				4
14	SS4110615SP	SCREW 11/64-40 L=6				2
15	SS6120940SP	SCREW 3/16-28 L=9				2
16	SS7110570SP	SCREW 11/64-40 L= 4.8				2
17	WZ0850302K0	WAVED WASHER 8.5X12.5X0.3				1
18	WP0450801SD	WASHER 4.5X10X0.8				2
19	WP0482086SD	WASHER 4.8X11.5X2				1

LUBRICATION COMPONENTS

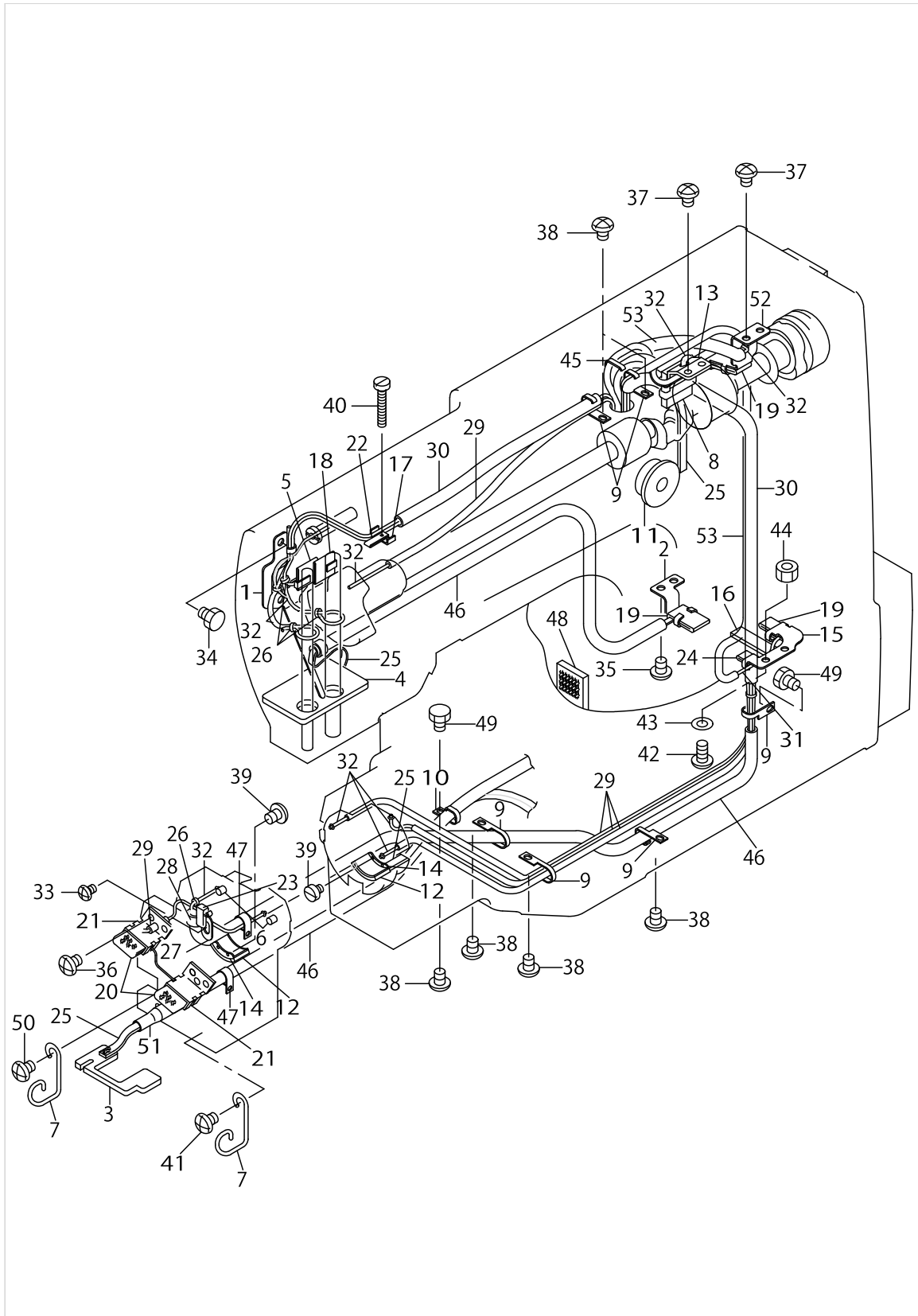

LUBRICATION COMPONENTS

No.	Parts No.	Parts name	Remarks	Level	Cons	Qty
1	13888409	OIL WICK PRESSER				1
2	13888508	LUBRICATING PLATE				1
3	13888607	OIL FELT				1
4	13888706	FACE OIL FELT				1
5	13888904	FACE LUBRICATING				1
6	11002904	ROLLER FELT				2
7	11021607	TUBE HOLDER (UPPER)				2
8	13529102	OIL FELT				1
9	13530209	LUBRICATING OIL WICK STOPPER				6
10	13530001	UPPER SHAFT FRONT METAL OIL WI				1
11	B3501210000	OIL GAUGE				1
12	B3504280000	SHUTTLE FELT				2
13	B3505210000	OIL FELT SUPPORTING PLATE				1
14	B3505280000	SHUTTLE LUBRICATING PLATE				2
15	B3506210000	OIL FELT SUPPORTING PLATE				1
16	B3507210000	OIL FELT				1
17	B3508280000	BALANCE LUBRICATING PLATE				1
18	B3509280000	NEEDLE ROD CRANK LUBRICATING				1
19	B3509280000	NEEDLE ROD CRANK LUBRICATING				1
20	B3509280000	NEEDLE ROD CRANK LUBRICATING				2
21	B3512280000	CRANK ROD LUBRICATING PLATE				2
22	B3518280000	BALANCE LUBRICATING				1
23	B3518280000	BALANCE LUBRICATING				1
24	B3518280000	BALANCE LUBRICATING				1
25	B3523220000	OIL FELT				4
26	B1419026000	OIL WICK PRESSER				5
27	B3520210000	OIL FELT SUPPORTING PLATE				1
28	B3523280000	OIL TUBE HOLDER				1
29	BP300000000	VINYL PIPE				2.4
30	BP600000000	VINYL PIPE				1.1
31	CQ202000000	OIL WICK				3.7
32	CQ252200000	OIL WICK				4.4
33	SS4090515SP	SCREW 9/64-40 L=5				1
34	SS9120643TP	SCREW 3/16-28 L=6				2
35	SS4120615SP	SCREW 3/16-28 L=6				2
36	SS4120615SP	SCREW 3/16-28 L=6				4
37	SS4120615SP	SCREW 3/16-28 L=6				4
38	SS4120615SP	SCREW 3/16-28 L=6				5
39	SS6090440SP	SCREW 9/64-40 L= 4.0				4
40	SS6092120SP	SCREW 9/64-40 L=21.2				1
41	SS4120615SP	SCREW 3/16-28 L=6				1
42	SS4120915SP	SCREW 3/16-28 L=9				2
43	WP0551016SH	WASHER 5.5X13X1				1
44	NS6120310SP	NUT 3/16-28				1
45	MAZ16526000	CLAMP				1
46	BP500000000	VINYL PIPE				1.1
47	EA9500B0100	CABLE BAND				2

LUBRICATION COMPONENTS

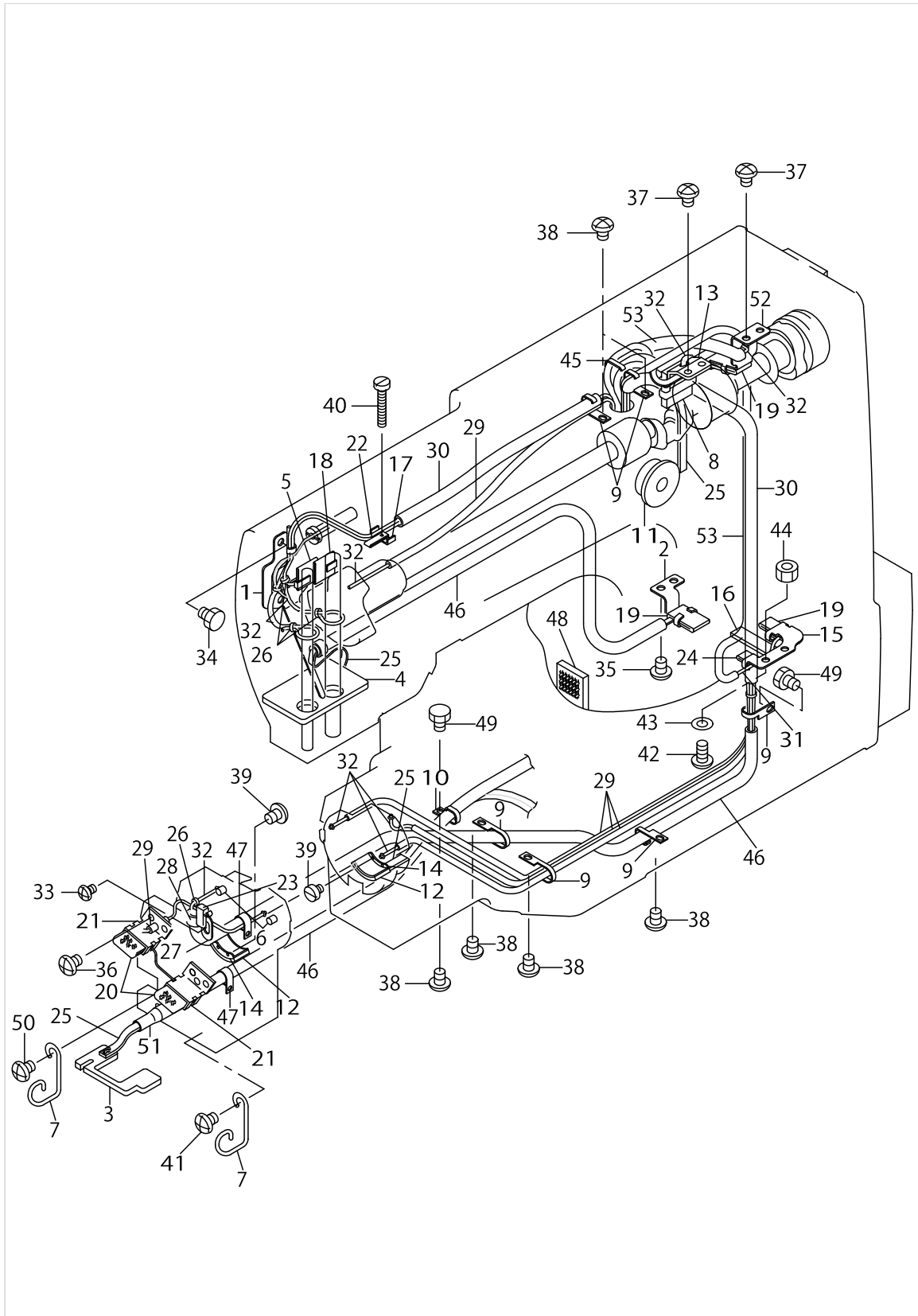

LUBRICATION COMPONENTS

No.	Parts No.	Parts name	Remarks	Level	Cons	Qty
48	B354677100A	LUBRICATING FELT				1
49	SS9120643TP	SCREW 3/16-28 L=6				2
50	SS4090615SP	SCREW 9/64-40 L=6				1
51	E8760452M00	TUBE				0.08
52	B3505210D00	CRANK ROD LUBRICATION PLATE				1
53	BP400000000	VINYL TUBE, WHITE D=4				0.5

THREAD STAND COMPONENTS

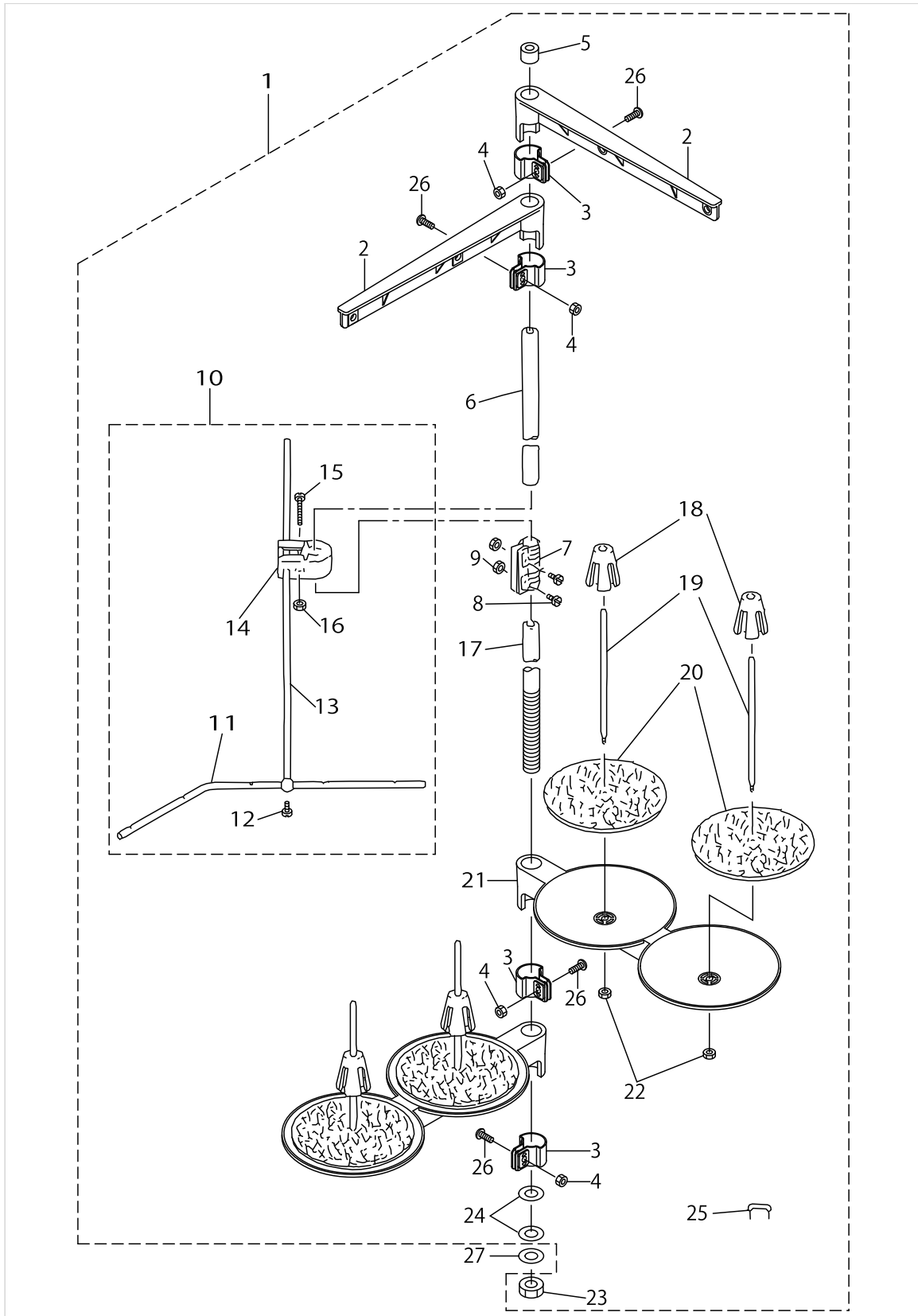

THREAD STAND COMPONENTS

No.	Parts No.	Parts name	Remarks	Level	Cons	Qty
1	11969458	THREAD STANDING DEVICE ASM.				1
2	11185352	THREAD GUIDE ASM.		*		2
3	11185402	THREAD GUIDE ARM JOINT		*		4
4	NM6050001SE	NUT M5		*		4
5	B3311704000	SPOOL REST ROD CAP		*		1
6	11185204	SPOOL REST ROD,UPPER		*		1
7	B3305704000A	SPOOL REST ROD JOINT		*		1
8	SM4051405SE	SCREW M5 L=14		*		2
9	NM6050001SE	NUT M5		*		2
10	B33097040A0	THREAD GUIDE ARM ASM.		*		1
11	B3311804000	LOWER THREAD GUIDE		*		1
12	SS7110540SP	SCREW 11/64-40 L=5		*		1
13	B3309704000	THREAD GUIDE ARM		*		1
14	B3304704000A	THREAD GUIDE ARM HOLDER		*		1
15	SM6053000SE	SCREW M5X0.8 L=30		*		1
16	NM6050001SE	NUT M5		*		1
17	11185105	SPOOL REST ROD,LOWER		*		1
18	11185501	SPOOL RETAINER		*		4
19	B3320704L00A	SPOOL PIN		*		4
20	B3311012000	SPOOL REST CUSHION		*		4
21	11185006	SPOOL REST ARM		*		2
22	NM6050001SE	NUT M5		*		4
23	B3317704000	NUT		*		1
24	WP1612616SE	WASHER 16X30X2.6		*		2
25	MAO11532000	CORD STAPLE		*		3
26	SM4051405SE	SCREW M5 L=14		*		4
27	WS1643202KR	SPRING WASHER				1

ACCESSORY PARTS COMPONENTS

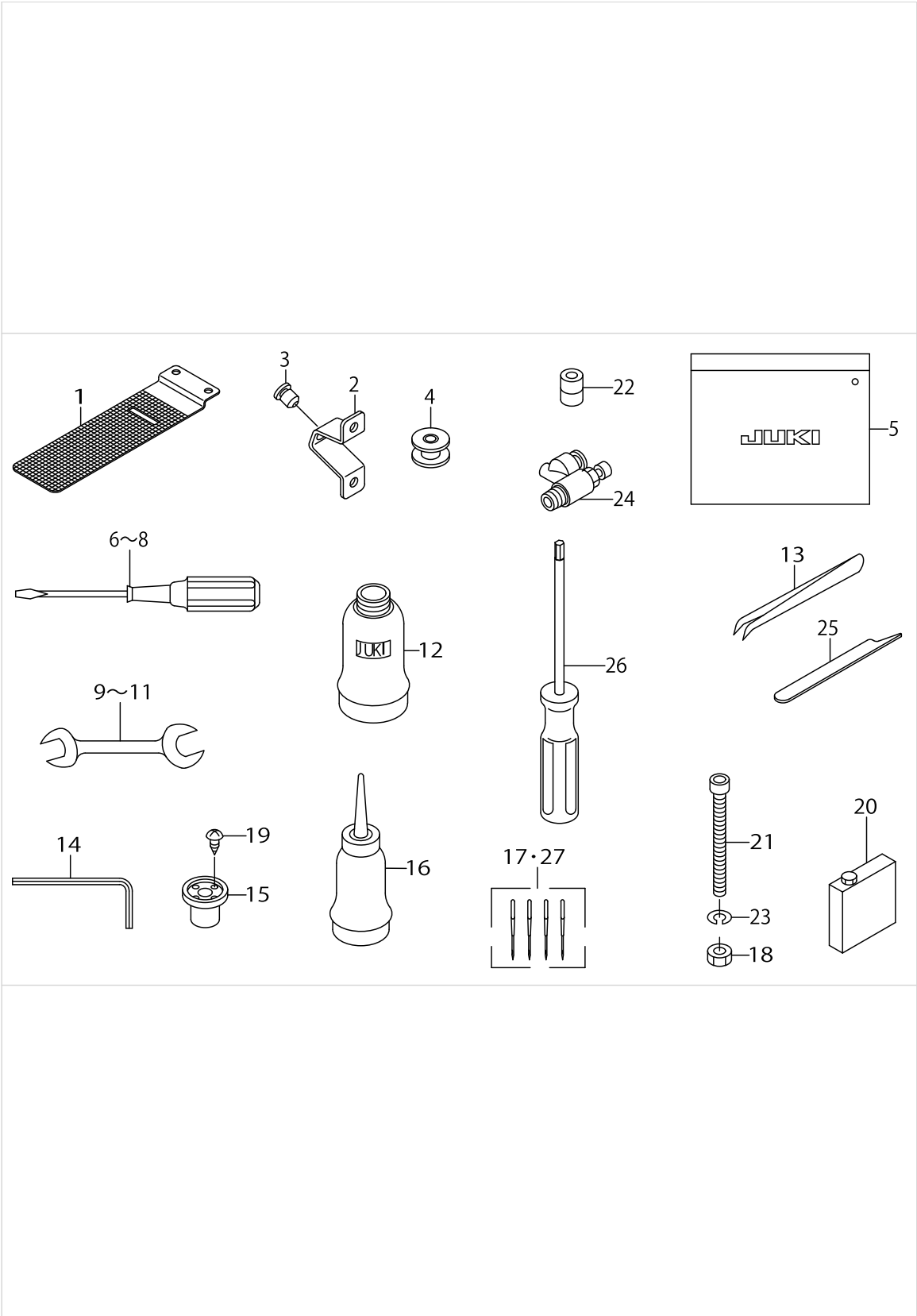

ACCESSORY PARTS COMPONENTS

No.	Parts No.	Parts name	Remarks	Level	Cons	Qty
1	13881008	LOWER PLATE BLANK				1
2	B1116205000	FRAME SUPPORT				1
3	B1117205000	RUBBER PAD				1
4	B1805210A00	BOBBIN				2
5	B9101552000	ACCESSORY BOX				1
6	B9109555000	SCREW DRIVER, LARGE				1
7	B9110012000	SCREW DRIVER, MIDDLE				1
8	B9111012000	SCREW DRIVER, SMALL				1
9	B9112012000	WRENCH (11X14)				1
10	B9113012000	WRENCH (9X10)				1
11	B9143372000	WRENCH (7.1 X 8.1)				1
12	B9121012000	OIL CAN				1
13	B9204804000	TWEEZERS				1
14	G91011160A0	L-SHAPED WRENCH ASM.				1
15	B8202205000	OIL MANAGEMENT				1
16	J1067000000	OILER				1
17	MDP170B2104	NEEDLE BAR DPX17 #21-4				1
18	NM6080001SC	NUT M8X1.25				5
19	SK3311601SC	WOOD SCREW D=3.1 L=16				4
20	MDFRX2700C0	NEW DEFRIX OIL NO.2(700CC)				1
21	SM6087002TN	SCREW M8 L=70				5
22	SS8150822TP	SCREW 15/64-28 L=8				2
23	WS0820002KN	SPRING WASHER M8				5
24	PC010521000	SPEED CONTROLLER				2
25	13876206	BOBBIN CASE REMOVAL PLATE				1
26	11851102	SCREW WRENCH				1
27	MDP170B1904	NEEDLE DPX17 #19-4	FOR LK-1952△A			1

PSC BOX UNIT COMPONENTS(1)

(Note) The spare fuse is not included in the PSC Box of this part No.

The outward from of PSC box varies by the area for use.

(注 記) 交換用ヒューズはこのパーツナンバーのPSCボックスには含まれていません。PSCボックスの出荷状態は使用する地域により変わります。

Ref. No.	Part No.	Export			JA		JE	EMC
		1 ϕ 100 ~120V	1 ϕ 200 ~240V	3 ϕ 200 ~240V	1 ϕ 100 ~120V	3 ϕ 200 ~240V	1 ϕ 200 ~240V	1 ϕ 200 ~240V
1	M2000356BA0			○				
2	M2000356CA0		○					
3	M2000356EA0					○		
4	M2000356FA0				○			
5	M2000356GA0						○	
6	M2000356HA0	○						
7	M2000356PA0							○

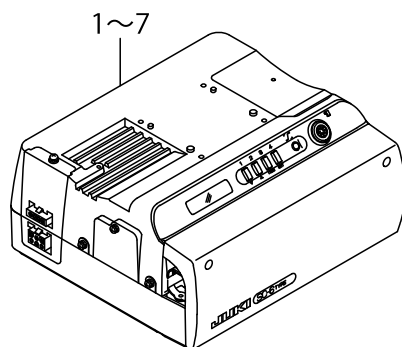

PSC BOX UNIT COMPONENTS(1)

No.	Parts No.	Parts name	Remarks	Level	Cons	Qty
1	M2000356BA0	PSC BOX BC ASM.				1
2	M2000356CA0	PSC BOX CC ASM.				1
3	M2000356EA0	PSC BOX EC ASM.				1
4	M2000356FA0	PSC BOX FC ASM.				1
5	M2000356GA0	PSC BOX GC ASM.				1
6	M2000356HA0	PSC BOX HC ASM.				1
7	M2000356PA0	PSC BOX PC ASM.				1

PSC BOX UNIT COMPONENTS(2)

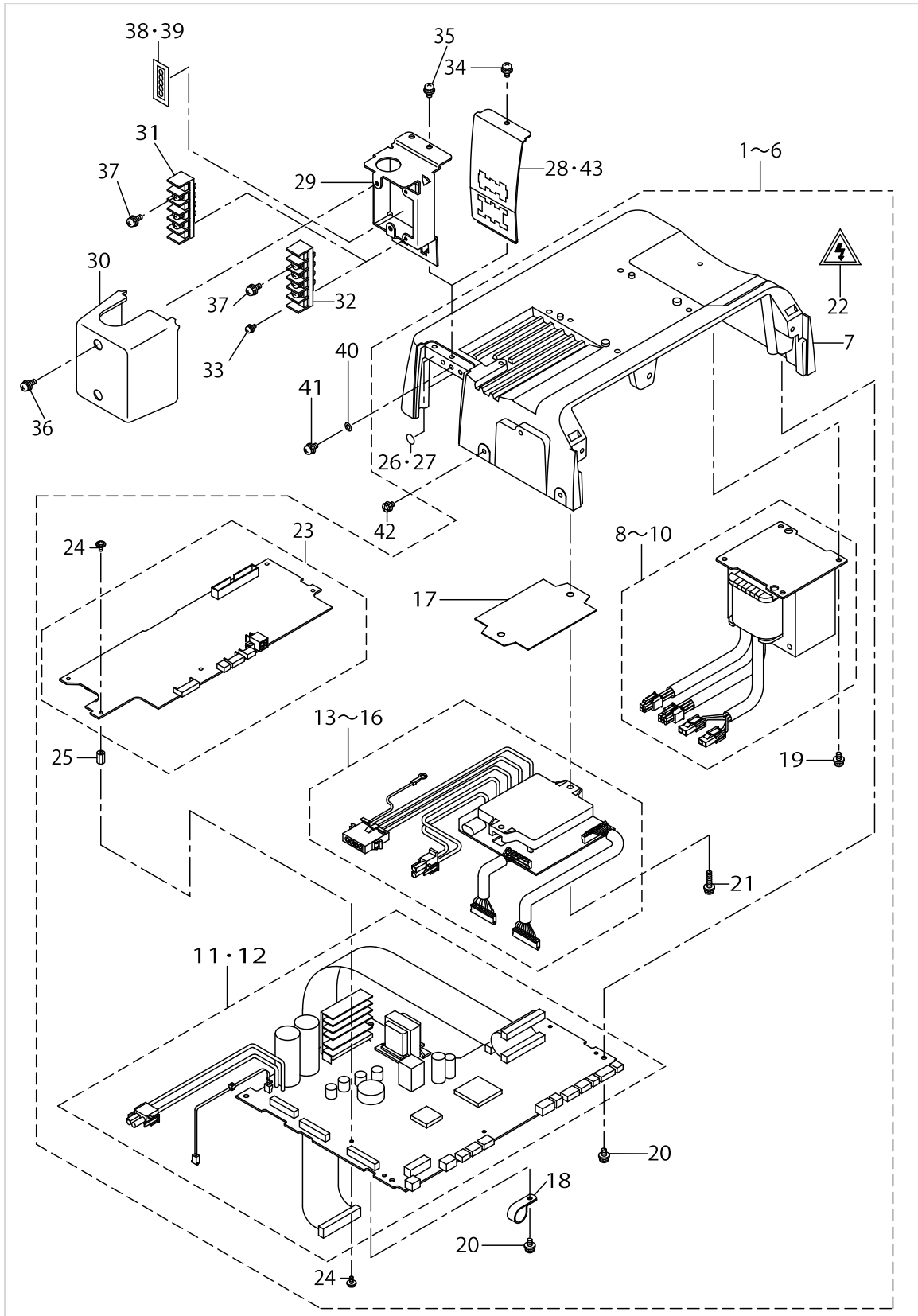

PSC BOX UNIT COMPONENTS(2)

No.	Parts No.	Parts name	Remarks	Level	Cons	Qty
1	M3002356BA0	UPPER COVER ASM., B	FOR JA,100V~120V 1φ			1
2	M3002356CA0	UPPER COVER ASM., C	COMMON USE PART 02,03			1
3	M3002356DA0	UPPER COVER ASM., D	FOR JE,200V~240V 1φ			1
4	M3002356EA0	UPPER COVER ASM., E	FOR JA,200V~240V 3φ			1
5	M3002356FA0	UPPER COVER ASM., F	FOR EXPORT,100V~120V 1φ			1
6	M3002356PA0	UPPER COVER ASM.,P	FOR EMC,200V~240V 1φ			1
7	M3001351000	BOX TOP COVER		*		1
8	M8502351BA0	TRANSFORMER ASM., B	COMMON USE PART 01,04	*		1
9	M8502351CA0	TRANSFORMER ASM., C	COMMON USE PART 02,03,05	*		1
10	M8502351DA0	TRANSFORMER ASM., D	COMMON USE PART 06,07	*		1
11	M8601351SAA	CTL. BOARD ASM., SA	COMMON USE PART 01~05	*		1
12	M8601351SAB	CTL. BOARD ASM., SB	COMMON USE PART 06,07	*		1
13	M8610351AAA	DRV. BOARD ASM., AA	COMMON USE PART 01~03	*		1
14	M8602351AAB	DRV. BOARD ASM., AB	FOR JE,200V~240V 1φ	*		1
15	M8610351AAC	DRV. BOARD ASM., AC	COMMON USE PART 04,05	*		1
16	M8610351AAP	DRV. BOARD ASM., AP	FOR EMC,200V~240V 1φ			1
17	M8802351000	TRANSISTOR SARCON		*		1
18	HX00150000H	CABLE CLIP		*		1
19	SL4041091SE	SCREW M4 L=10		*		4
20	SL4041091SE	SCREW M4 L=10		*		6
21	SL4041681SF	SCREW M4 L=16		*		2
22	CM300100001	LABEL	COMMON USE PART 06,07	*		1
23	M8601356AA0	LKSUB. BASE A ASM.		*		1
24	SL4030891SC	SCREW M3X8		*		10
25	HX004180000	PCB PARTS		*		5
26	E9567319000	EARTH MARK	COMMON USE PART 01~05	*		1
27	CM200100001	PE MARK LABEL	COMMON USE PART 06,07	*		1
28	M3801351A00	CONNECTOR FITTING PLATE A	COMMON USE PART 01~03			1
29	M3802351000	TERMINAL BASE FITTING PLATE	COMMON USE PART 04,05			1
30	M3803351000	TERMINAL BASE COVER	COMMON USE PART 04,05			1
31	HK04905003A	TERMINAL BASE 3P	FOR JA,100V~120V 1φ			1
32	HK049050040	TERMINAL BASE 4P	FOR JA,200V~240V 3φ			1
33	SL4031081SF	SCREW M3 L=10	COMMON USE PART 04,05			2
34	SL4041091SE	SCREW M4 L=10	COMMON USE PART 01~03,06			1
35	SL4041091SE	SCREW M4 L=10	COMMON USE PART 04,05			2
36	SL4041281SF	SCREW M4 L=12	COMMON USE PART 04,05			2
37	SL4040885SH	SCREW M4 L=8	COMMON USE PART 04,05			1
38	M7007351A00	TERMINAL BASE LABEL, A	FOR JA,200V~240V 3φ			1
39	M7007351B00	TERMINAL BASE LABEL, B	FOR JA,100V~120V 1φ			1
40	WT0430001KN	TOOTHED WASHER				3
41	SL4041091SE	SCREW M4 L=10				3
42	SL4040855SE	SCREW M4 L=8				3
43	M3801351000	CONNECTOR FITTING PLATE	COMMON USE PART 06,07			1

PSC BOX UNIT COMPONENTS(3)

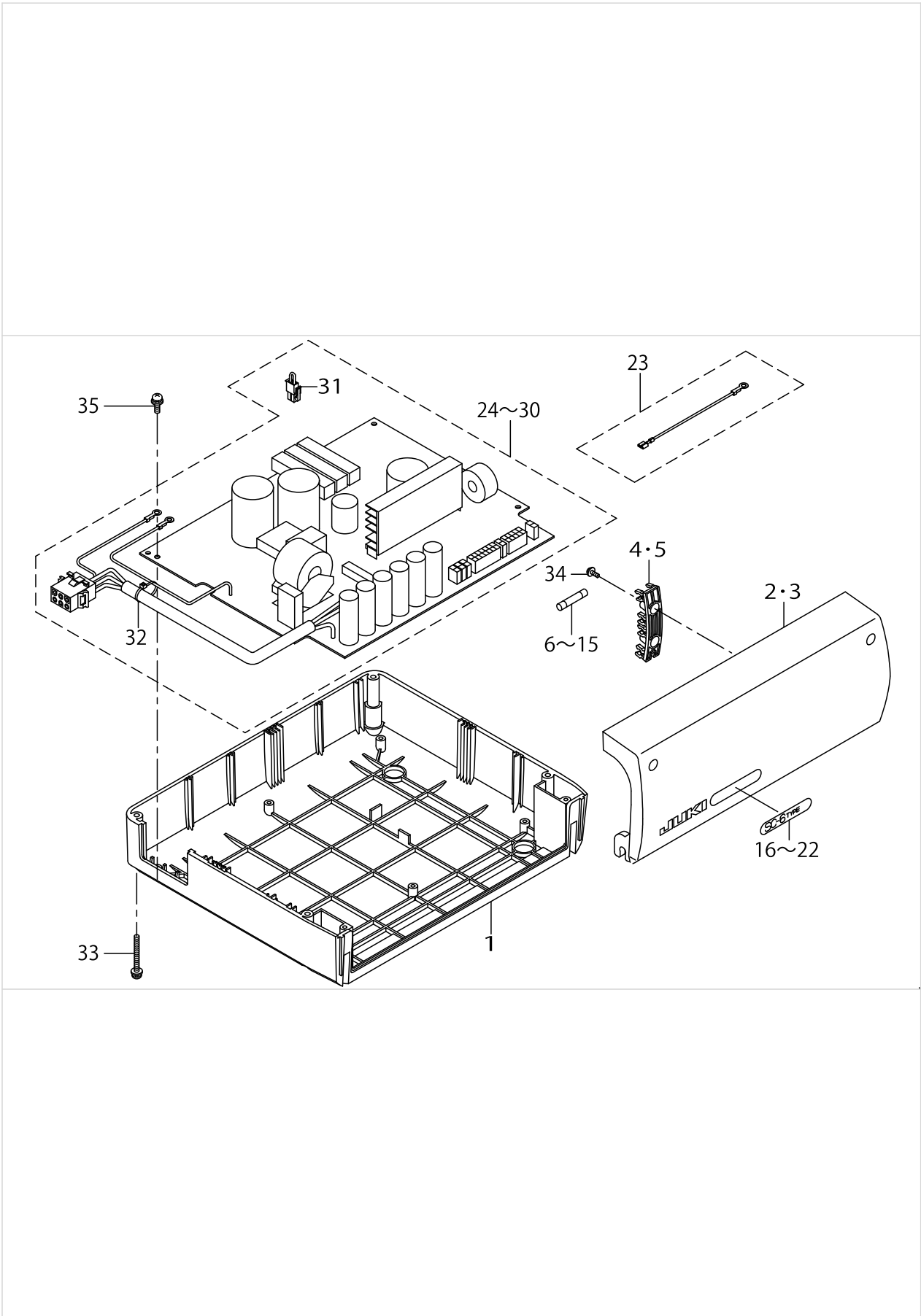

PSC BOX UNIT COMPONENTS(3)

No.	Parts No.	Parts name	Remarks	Level	Cons	Qty
1	M3201351000A	BOTTOM COVER				1
2	M3405351AAA	FRONT COVER ASM., A	COMMON USE PART 01~05			1
3	M3405351AAA	FRONT COVER ASM., A	COMMON USE PART 06,07			1
4	M3403351000	FUSE HOLDER A	COMMON USE PART 01~05			1
5	M3404351000	FUSE HOLDER B	COMMON USE PART 06,07			1
6	HF0078016P0	FUSE 250VT 1.6A	COMMON USE PART 06,07			1
7	HF0078050S0	FUSE 250VT 0.5A	COMMON USE PART 06,07			1
8	HF0079016P0	FUSE 250VT 1.6A	COMMON USE PART 01~05			1
9	HF0079030P0	FUSE 250VT 3A	FOR EXPORT,100V~120V 1φ			1
10	HF0079050S0	FUSE 250VT 0.5A	COMMON USE PART 01~05			1
11	HF008001200	FUSE 250V 12A	COMMON USE PART 03,05			1
12	HF008102000	FUSE 250VT 20A	COMMON USE PART 01,02,04			1
13	HF008101500	FUSE 250VT 15A	FOR EMC,200V~240V 1φ			1
14	HF0079018P0	FUSE 250VT 1.8A	FOR JA,200V~240V 3φ			1
15	HF0079032P0	FUSE 250VT 3.2A	FOR JA,100V~120V 1φ			1
16	M7002356B0C	SC-6 TYPE PLATE, BC	FOR EXPORT,200V~240V 3φ			1
17	M7002356C0C	SC-6 TYPE PLATE, CC	FOR EXPORT,200V~240V 1φ			1
18	M7002356E0C	SC-6 TYPE PLATE, EC	FOR JA,200V~240V 3φ			1
19	M7002356F0C	SC-6 TYPE PLATE, FC	FOR JA,100V~120V 1φ			1
20	M7002356G0C	SC-6 TYPE PLATE, GC	FOR JE,200V~240V 1φ			1
21	M7002356H0C	SC-6 TYPE PLATE, HC	FOR EXPORT,100V~120V 1φ			1
22	M7002356P0C	SC-6 TYPE PLATE,PC	FOR EMC,200V~240V 1φ			1
23	M8519351BA0	FG. CORD B ASM.	COMMON USE PART 04,05			1
24	M8604351BAB	POWER SOURCE BOARD BB ASM.	FOR EXPORT,200V~240V 3φ			1
25	M8605351CAB	POWER SOURCE BOARD CB ASM.	FOR EXPORT,200V~240V 1φ			1
26	M8604351EAB	POWER SOURCE BOARD EB ASM.	FOR JA,200V~240V 3φ			1
27	M8605351FAB	POWER SOURCE BOARD FB ASM.	FOR JA,100V~120V 1φ			1
28	M8605351GAB	POWER SOURCE BOARD GB ASM.	FOR JE,200V~240V 1φ			1
29	M8605351HAB	POWER SOURCE BOARD HB ASM.	FOR EXPORT,100V~120V 1φ			1
30	M8609351PAB	POWER SOURCE BOARD PB ASM.	FOR EMC,200V~240V 1φ			1
31	M8524351AA0	INPUT CHANGING CORD ASM., A		*		1
32	EA9500B0100	CABLE BAND		*		1
33	SL4044091SE	SCREW M4 L=40				4
34	SV4030801SS	TAPPING SCREW				2
35	SL4041081SF	SCREW M4 L=10				6

PSC BOX UNIT COMPONENTS(4)

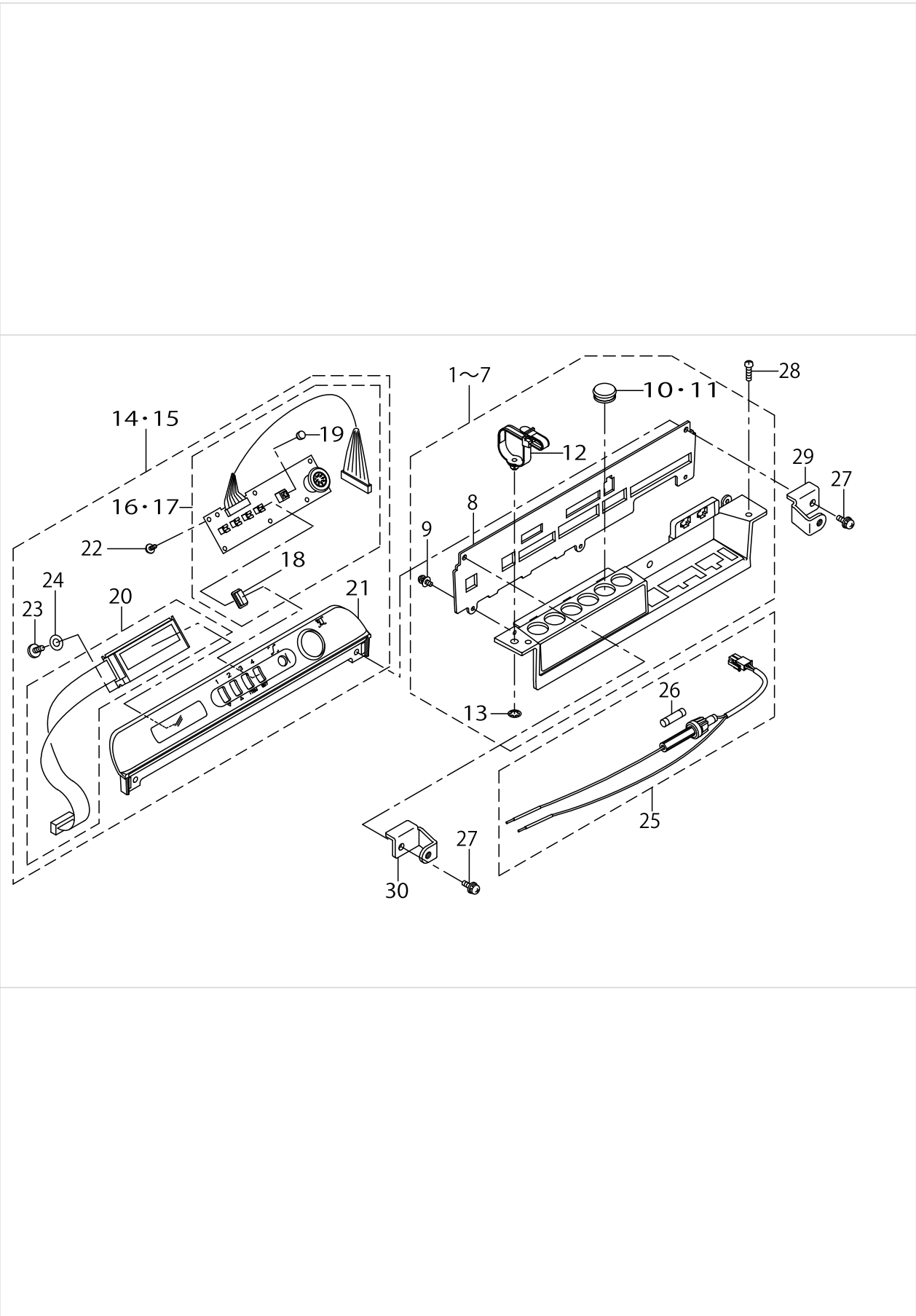

PSC BOX UNIT COMPONENTS(4)

No.	Parts No.	Parts name	Remarks	Level	Cons	Qty
1	M3401356BA0	CONNECTOR PANEL ASM., B	FOR EXPORT,200V~240V 3φ			1
2	M3401356CA0	CONNECTOR PANEL ASM., C	FOR EXPORT,200V~240V 1φ			1
3	M3401356EA0	CONNECTOR PANEL ASM., E	FOR JA,200V~240V 3φ			1
4	M3401356FA0	CONNECTOR PANEL ASM., F	FOR JA,100V~120V 1φ			1
5	M3401356GA0	CONNECTOR PANEL ASM., G	FOR JE,200V~240V 1φ			1
6	M3401356HA0	CONNECTOR PANEL ASM., H	FOR EXPORT,100V~120V 1φ			1
7	M3401356PA0	CONNECTOR PLATE ASM.,P	FOR EMC,200V~240V 1φ			1
8	M3401356000	CONNECTOR PANEL LKB		*		1
9	SV4031006SR	SCREW M3 L=10		*		3
10	HX00326000G	PLUG	FOR JE,200V~240V 1φ	*		3
11	HX00326000G	PLUG	COMMON USE PART 01,02,04,07	*		1
12	HX003820000	CABLE CLAMP		*		1
13	NP210580000	PUSH NUT		*		1
14	M3601355AA0	INDICATOR A ASM.	COMMON USE PART 01~05			1
15	M3601355BA0	INDICATOR B ASM.	COMMON USE PART 06,07			1
16	M8607351AAA	SW. BOARD ASM., AA	COMMON USE PART 01~05	*		1
17	M8607351AAB	SW. BOARD ASM., AB	COMMON USE PART 06,07	*		1
18	M3603351000	SWITCH KEY TOP		*		4
19	HA003640010	SWITCH KEY TOP		*		1
20	M8503351AA0	LCD. UNIT ASM., A		*		1
21	M3601355000	SWITCH PANEL LK		*		1
22	SV4030801SS	TAPPING SCREW		*		6
23	ST4031021SR	TAPPING SCREW D=3 L=10		*		1
24	M3604351000	SPACER		*		1
25	M8525351AA0	LAMP FUSE HOLDER ASM., A	COMMON USE PART 01~05			1
26	M9644110000	FUSE 8A	COMMON USE PART 01~05	*		1
27	SL4042081SF	SCREW M4 L=20				2
28	SL4031081SF	SCREW M3 L=10				2
29	M3402356000	COVER BRACKET, R				1
30	M3403356000	COVER BRACKET, L				1

HOW TO MAKE USE OF THIS PARTS LIST

1.Explanation of codes

1)"*"mark.....means this part is changed from the previous parts book.

As to the details of the change, refer to the "List for information of change".

2)"#01".....refer to "Note" explanation at bottom of page.

2.Codes on the "Qty" column

- Each numeral indicates the number of parts required.
- "0.1" and "2.5" indicate the length (in meters) of the respective parts.

3.Parentheses mean that the corresponding part is a subpart that constructs an assembly part.

4.Dotted lines on the Figures indicate assembly parts.

1."注記"欄の記号説明

1) "*"印.....前回のパーツブックに比較して今回変更された部品を意味します。

変更内容は、"変更情報リスト"を参照してください。

2) "#01".....ページ下の"注記"の説明を参照してください。

2.数量欄の数字は、個数を表し、0.1、2.5等の数値は、長さ（単位メートル）を表します。

3.数量欄の（ ）は、組部品を構成している子部品であることを意味します。

4.イラストページの-----枠は、組構成であることを意味します。

NUMERICAL INDEX OF PARTS

PART NO	PAGE	REF NO.	PART NO	PAGE	REF NO.	PART NO	PAGE	REF NO.
10064400	40	5	13807904	24	20	13874706	6	40
10120004	24	16	13859657	2	27	13874805	6	41
10502300	30	8	13867957	14	15	13874904	6	42
10527208	32	17	13870050	2	1	13875000	6	43
11001005	4	68	13870209	30	3	13875109	6	44
11002904	44	6	13870258	30	2	13875208	6	45
11021607	44	7	13870266	30	1	13875307	8	48
11032265	6	15	13870605	30	4	13875406	8	49
11041100	32	18	13870704	2	2	13875604	16	50
11102308	30	7	13870852	2	3	13875604	18	5
11185006	48	21	13870902	2	4	13875752	6	47
11185105	48	17	13870902	28	20	13875760	6	46
11185204	48	6	13871009	2	5	13875810	8	50
11185352	48	2	13871108	2	6	13875919	8	51
11185402	48	3	13871108	28	19	13876008	8	62
11185501	48	18	13871207	2	7	13876107	8	63
11272408	34	69	13871306	2	8	13876206	50	25
11274107	40	6	13871454	2	9	13876305	10	1
11851102	50	26	13871504	2	10	13876305	32	34
11969458	48	1	13871603	2	20	13876404	10	2
13502604	2	22	13871702	2	11	13876503	10	3
13503206	6	16	13871801	2	12	13876602	10	4
13503305	6	17	13872007	2	14	13876602	32	39
13503404	6	18	13872106	2	15	13876719	10	5
13508403	10	10	13872205	2	16	13876719	34	49
13513114	40	7	13872304	4	70	13876800	10	6
13514310	24	17	13872403	36	1	13876909	10	7
13515101	24	21	13872650	6	5	13877006	10	8
13515309	24	18	13873005	6	1	13877105	10	9
13516208	16	61	13873104	6	2	13877303	32	1~4
13516208	18	18	13873252	6	4	13877402	32	1~4
13516604	18	11~15	13873260	6	3	13877501	32	1~4
13516703	18	11~15	13873302	6	10	13877600	32	1~4
13516802	18	11~15	13873450	36	2	13877709	18	4
13518907	18	16	13873658	6	11	13877808	16	67
13519103	18	11~15	13873708	6	12	13877808	20	48
13519202	18	11~15	13873807	6	13	13877907	16	51
13529102	44	8	13873906	6	14	13877907	18	6
13530001	44	10	13874052	30	5	13878053	14	1
13530209	44	9	13874102	22	7	13878152	14	3
13534060	24	19	13874250	42	7	13878251	14	2
13542006	2	23	13874300	34	65	13878558	14	16
13722509	40	8	13874409	42	3	13878608	14	17
13760707	22	15	13874508	6	38	13878707	14	4
13768155	2	24	13874607	6	39	13878806	14	6

NUMERICAL INDEX OF PARTS

PART NO	PAGE	REF NO.	PART NO	PAGE	REF NO.	PART NO	PAGE	REF NO.
13878905	14	5	13883350	22	9	13887807	36	15
13879002	18	1	13883368	22	8	13887906	34	51
13879101	18	2	13883400	22	33	13888003	36	17
13879200	14	18	13883509	22	12	13888102	36	18
13879309	14	19	13883608	22	13	13888201	32	16
13879408	14	13	13883715	28	6	13888409	44	1
13879507	18	3	13883756	28	1	13888508	44	2
13879606	34	67	13883806	28	7	13888607	44	3
13879705	14	7	13883905	22	41	13888706	44	4
13879804	4	72	13884002	22	14	13888805	36	19
13879903	4	73	13884119	28	21	13888904	44	5
13880000	14	14	13884218	28	4	13889001	42	4
13880109	14	8	13884309	26	55	13889100	42	1
13880208	14	9	13884309	38	56	13889209	42	2
13880307	14	11	13884408	16	63~65	13889308	42	5
13880406	14	12	13884507	40	2	13889407	42	6
13880505	14	10	13884606	40	3	13889704	30	6
13880604	16	52	13884705	40	4	13889951	30	31
13880604	18	8	13884804	16	63~65	13890009	8	76~78
13880703	16	53	13884903	16	63~65	13890108	8	76~78
13880703	18	9	13885256	36	3	13890207	8	76~78
13880802	16	54	13885306	32	5	13890454	22	24
13880802	18	10	13885454	32	6	13890504	30	44
13880901	18	7	13885603	34	55	13922208	2	26
13881008	50	1	13885702	36	5	13922208	28	17
13881255	24	14	13885801	32	7	16189508	34	54
13881255	38	51	13885900	32	8	16201501	28	8
13881305	24	12	13886015	32	9	16992604	34	68
13881404	24	1	13886106	34	56	17834706	42	8
13881503	24	2	13886205	34	52	18036707	4	78~81
13881602	24	3	13886304	36	8	18036806	4	78~81
13881701	24	4	13886411	32	10	18036905	4	78~81
13881800	24	5	13886502	32	11	18037002	4	78~81
13881909	24	6	13886601	32	12	25002809	28	2
13882006	24	7	13886700	36	9	25002908	28	5
13882105	24	8	13886809	36	10	A3125002000	22	40
13882204	24	9	13886908	36	11	B1104280000	4	69
13882303	24	10	13887005	32	13	B1107280000	2	17
13882402	24	11	13887104	32	14	B1110280000	30	11
13882501	24	15	13887203	32	15	B1115232000	22	39
13882501	38	50	13887302	36	12	B11152320A0	22	36
13882659	24	13	13887401	34	63	B1116205000	50	2
13883004	22	10	13887450	34	62	B1116804000	2	19
13883103	22	11	13887500	36	13	B1117205000	50	3
13883251	22	1	13887708	36	14	B1135210000	4	67

NUMERICAL INDEX OF PARTS

PART NO	PAGE	REF NO.	PART NO	PAGE	REF NO.	PART NO	PAGE	REF NO.
B1136850000	28	3	B18122100A0	10	24	B250228000A	18	44~47
B1144771000	2	18	B18122100A0	32	23	B250228000B	18	44~47
B1144771000	28	18	B1813980000	10	25	B250228000C	18	44~47
B120898000A	6	19~22	B1813980000	32	24	B250228000D	18	44~47
B120898000B	6	19~22	B1814980000	10	26	B2506980000	18	22
B120898000C	6	19~22	B1815210000	10	27	B2508280000	18	23
B120898000D	6	19~22	B1815210000	32	25	B2548280000	14	23
B1210980000	6	23	B1816280000	10	15	B2549280000	14	24
B1211804000	6	27	B1816280000	34	61	B2597210000	36	34
B1211980000	6	24	B1819280000	10	28	B2612372000	30	32
B1220771000	6	25	B1823280000	12	53	B3013141H0A	42	9
B1223771000	6	26	B18282100A0	10	30	B3035280000	8	67
B1411804A00	10	11~14	B18282100A0	34	50	B3041980000	30	9
B1411804A00	32	19~22	B1831220000	10	31	B3107352000	30	33
B1411804B00	10	11~14	B1903552000	8	52	B3108352000	30	34
B1411804B00	32	19~22	B1903552000	32	26	B3114232000	22	22
B1411804C00	10	11~14	B1904280000	8	68	B3116125000	22	17
B1411804C00	32	19~22	B1905541A00	32	27~30	B3120125000	22	18
B1411804D00	10	11~14	B1905541B00	32	27~30	B3123352000	22	37
B1411804D00	32	19~22	B1905541C00	32	27~30	B3125012000	22	19
B1414226000	36	21	B1905541D00	32	27~30	B3125012000	30	35
B1414232000	8	64~66	B2019372000	22	16	B3125527000	22	20
B141423200A	8	64~66	B2039373000	2	25	B3126012000	22	38
B141423200B	8	64~66	B2207280000	14	22	B3126012000	30	36
B1419026000	44	26	B2404280000	24	23	B3129771000	30	37
B1430180A00	8	53~56	B2410980000	24	24	B3132552000	22	23
B1430180B00	8	53~56	B2417210000	24	25	B3138527000	22	25
B1430180C00	8	53~56	B2417210000	36	25	B3140527000	22	26
B1430180D00	8	53~56	B242328000A	24	26~32	B3141527000	22	27
B1605761000	14	20	B242328000A	36	26~32	B3208280000	30	26
B1606761000	14	21	B242328000B	24	26~32	B3212761000	30	30
B1608774000	18	20	B242328000B	36	26~32	B3304704000A	48	14
B1623180000	36	22	B242328000C	24	26~32	B3305704000A	48	7
B1631012B00	24	22	B242328000C	36	26~32	B3309704000	48	13
B1631012B00	40	9	B242328000D	24	26~32	B33097040A0	48	10
B1801980000	10	16	B242328000D	36	26~32	B3311012000	48	20
B1804280000	10	17	B242328000E	24	26~32	B3311704000	48	5
B1805210A00	10	18	B242328000E	36	26~32	B3311804000	48	11
B1805210A00	34	59	B242328000F	24	26~32	B3317704000	48	23
B1805210A00	50	4	B242328000F	36	26~32	B3320704L00A	48	19
B18069800AA	10	19~23	B242328000G	24	26~32	B3413227000	30	12
B18069800AB	10	19~23	B242328000G	36	26~32	B3501210000	44	11
B18069800AC	10	19~23	B2424210000	24	33	B3502280000	2	28
B18069800AY	10	19~23	B2424210000	36	33	B3504280000	44	12
B18069800AZ	10	19~23	B2501280000	18	21	B3505210000	44	13

NUMERICAL INDEX OF PARTS

PART NO	PAGE	REF NO.	PART NO	PAGE	REF NO.	PART NO	PAGE	REF NO.
B3505210D00	46	52	D1807555B00	32	31	M3002356DA0	54	1~6
B3505280000	44	14	D2112555B00	2	30	M3002356EA0	54	1~6
B3506210000	44	15	D2464555B00	24	34	M3002356FA0	54	1~6
B3507210000	44	16	D2629M1YC0F	40	10	M3002356PA0	54	1~6
B3508280000	44	17	E8760452M00	46	51	M3201351000A	56	1
B3509280000	44	20	E9567319000	54	26·27	M3401356000	58	8
B3512280000	44	21	EA9500B0100	2	33	M3401356BA0	58	1~7
B3518280000	44	24	EA9500B0100	44	47	M3401356CA0	58	1~7
B3520210000	44	27	EA9500B0100	56	32	M3401356EA0	58	1~7
B3523220000	44	25	G91011160A0	50	14	M3401356FA0	58	1~7
B3523280000	44	28	GAK33012000	24	35	M3401356GA0	58	1~7
B354677100A	46	48	GBR01525000	40	11	M3401356HA0	58	1~7
B3928880000	22	5	GPK14012000	2	31	M3401356PA0	58	1~7
B8202205000	50	15	HA003640010	58	19	M3402356000	58	29
B8233555000	2	29	HF0078016P0	56	6~15	M3403351000	56	4·5
B9101552000	50	5	HF0078050S0	56	6~15	M3403356000	58	30
B9109555000	50	6~8	HF0079016P0	56	6~15	M3404351000	56	4·5
B9110012000	50	6~8	HF0079018P0	56	6~15	M3405351AAA	56	2·3
B9111012000	50	6~8	HF0079030P0	56	6~15	M3601355000	58	21
B9112012000	50	9~11	HF0079032P0	56	6~15	M3601355AA0	58	14·15
B9113012000	50	9~11	HF0079050S0	56	6~15	M3601355BA0	58	14·15
B9121012000	50	12	HF008001200	56	6~15	M3603351000	58	18
B9143372000	50	9~11	HF008101500	56	6~15	M3604351000	58	24
B9204804000	50	13	HF008102000	56	6~15	M3801351000	54	28·43
BP300000000	44	29	HK04905003A	54	31	M3801351A00	54	28·43
BP400000000	46	53	HK049050040	54	32	M3802351000	54	29
BP500000000	44	46	HX001230000	30	10	M3803351000	54	30
BP600000000	44	30	HX00150000A	36	36	M6211350BAA	2	32
BT0400251ED	28	9	HX00150000H	54	18	M6212350BAA	4	63
BT0600401EF	38	52	HX00221000C	30	43	M6213350BAA	4	66
CM200100001	54	26·27	HX00221000F	2	34	M7002356B0C	56	16~22
CM300100001	54	22	HX00326000G	58	10·11	M7002356C0C	56	16~22
CM3002000B1	4	76	HX003820000	58	12	M7002356E0C	56	16~22
CM300200101	4	77	HX004180000	54	25	M7002356F0C	56	16~22
CQ202000000	44	31	J1067000000	50	16	M7002356G0C	56	16~22
CQ252200000	44	32	M2000356BA0	52	1~7	M7002356H0C	56	16~22
CS0640611SP	30	28	M2000356CA0	52	1~7	M7002356P0C	56	16~22
CS079073ASH	10	33	M2000356EA0	52	1~7	M7007351A00	54	38·39
CS080081ASH	10	34	M2000356FA0	52	1~7	M7007351B00	54	38·39
CS0801011TH	32	32	M2000356GA0	52	1~7	M8502351BA0	54	8~10
CS100101BSH	40	12	M2000356HA0	52	1~7	M8502351CA0	54	8~10
CS1201010SH	32	33	M2000356PA0	52	1~7	M8502351DA0	54	8~10
CS1801211SH	14	25	M3001351000	54	7	M8503351AA0	58	20
CS180121ASH	14	26	M3002356BA0	54	1~6	M8519351BA0	56	23
D1805MLBH00	10	32	M3002356CA0	54	1~6	M8524351AA0	56	31

NUMERICAL INDEX OF PARTS

PART NO	PAGE	REF NO.	PART NO	PAGE	REF NO.	PART NO	PAGE	REF NO.
M8525351AA0	58	25	NS6361040SP	14	27	SD0651301TH	24	45
M8601351SAA	54	11·12	NS6660430SP	10	35	SD0720221SP	30	14
M8601351SAB	54	11·12	NS6660430SP	18	26	SD0720222TP	30	13
M8601356AA0	54	23	NS6660511SP	14	28	SD0801021TP	10	40
M8602351AAB	54	13~16	PA1001022A0	28	10	SD0870602SP	14	29
M8604351BAB	56	24~30	PA1002501A0	16	56	SD0901201TP	24	46
M8604351EAB	56	24~30	PA1002501A0	18	27	SD0951501SP	14	30
M8605351CAB	56	24~30	PA1004001A0	2	35	SK3311601SC	50	19
M8605351FAB	56	24~30	PA1501515A0	36	38	SK3412001SC	30	45
M8605351GAB	56	24~30	PA2001501A0	24	36	SL4030591SC	30	19
M8605351HAB	56	24~30	PC010521000	50	24	SL4030891SC	54	24
M8607351AAA	58	16·17	PJ046054002	36	39	SL4031081SF	54	33
M8607351AAB	58	16·17	PJ301060501	24	37	SL4031081SF	58	28
M8609351PAB	56	24~30	PJ301065104	24	38	SL4031281SC	30	17
M8610351AAA	54	13~16	PJ304040504	2	36	SL4031481SC	30	18
M8610351AAC	54	13~16	PJ304040504	16	57	SL4040855SE	54	42
M8610351AAP	54	13~16	PJ304040504	18	28	SL4040885SH	54	37
M8802351000	54	17	PJ304040504	28	11	SL4041081SF	56	35
M9644110000	58	26	PS0250081K0	42	11	SL4041091SE	54	41
MAO11532000	48	25	PS0250162KH	10	36	SL4041281SF	54	36
MAZ16526000	44	45	PS0250162KH	32	35	SL4041681SF	54	21
MDFRX2700C0	50	20	PS0250202KH	42	10	SL4042081SF	58	27
MDP170B1900	8	69·80	RC0150001KP	6	28	SL4044091SE	56	33
MDP170B1904	50	17·27	RC1021011KP	24	39	SL4051001MZ	6	29
MDP170B2100	8	69·80	RC1991214KP	10	37	SM1020801SN	2	37
MDP170B2104	50	17·27	RC2200002KP	10	38	SM1030401SE	36	42
MTJVH00500A	8	84	RE0300000K0	16	58	SM4030455SN	34	58
NM6030001SC	30	23	RE0300000K0	18	29	SM4030455SN	36	4
NM6050001SE	48	22	RE0400000K0	36	40	SM4051405SE	48	26
NM6050001SP	36	37	RE0400000KP	24	40	SM5040601SC	42	13
NM6060001SC	40	13	SB112000200	32	36	SM6030860SP	16	55
NM6080001SC	50	18	SB30400020A	8	57	SM6030860SP	18	31
NP210580000	58	13	SB30800080A	8	58~61	SM6040602TN	14	32
NS6090310SP	18	32	SB30800080B	8	58~61	SM6041202TN	16	59
NS6090310SP	34	66	SB30800080C	8	58~61	SM6041202TN	18	30
NS6090310SP	40	14	SB30800080D	8	58~61	SM6052002TP	14	34
NS6110420SP	30	27	SB312000400	10	39	SM6052502TP	14	35
NS6120310SP	22	35	SB612000100	32	37	SM6053000SE	48	15
NS6120310SP	24	43	SD0550271TP	40	17	SM6061802TP	40	20
NS6120310SP	44	44	SD0600411TP	40	15	SM6081552TP	14	33
NS6150310SP	22	6	SD0601021SP	40	16	SM6083042CH	2	21
NS6150430SN	30	38	SD0640241SP	22	29	SM6087002TN	50	21
NS6150430SP	18	24	SD0640752TP	36	41	SM6860552TP	8	70
NS6150440SP	18	25	SD0640851SP	42	12	SM9030650SN	38	53
NS6160520SP	22	28	SD0650305TP	24	44	SS1060210TP	24	47

NUMERICAL INDEX OF PARTS

PART NO	PAGE	REF NO.	PART NO	PAGE	REF NO.	PART NO	PAGE	REF NO.
SS1060210TP	36	6	SS6151412TP	36	20	SS8150710TP	12	49
SS1090920SP	18	33	SS6151440SP	26	50	SS8150822TP	8	82
SS1121010SP	18	34	SS6151920TP	26	54	SS8150822TP	18	40
SS1121010SP	28	13	SS6152212SP	18	36	SS8150822TP	50	22
SS2111140SP	34	57	SS6153040SP	14	38	SS8151550SP	6	7
SS4090515SP	44	33	SS6242272TP	36	23	SS8151770SP	6	6
SS4090610SP	4	52	SS6661110SP	14	39	SS8660330SP	32	41
SS4090615SP	46	50	SS6681712TP	6	31	SS8660410SP	14	44
SS4110615SP	42	14	SS7090410SP	26	51	SS8660522TP	32	42
SS4120615SP	2	57	SS7090410SP	36	35	SS8660610TP	6	33
SS4120615SP	4	57	SS7090520SP	22	30	SS8660612TP	6	34
SS4120615SP	44	41	SS7110410SP	28	15	SS8660612TP	12	50
SS4120915SP	2	45	SS7110510SP	28	16	SS8660612TP	32	44
SS4120915SP	44	42	SS7110540SP	48	12	SS8660612TP	40	19
SS4150915SP	2	44	SS7110570SP	42	16	SS8661012TP	6	35
SS5090610SP	34	60	SS7110710SP	4	74	SS8661012TP	32	45
SS6060410TP	10	41	SS7110710SP	36	44	SS8661212TP	6	36
SS6060410TP	32	38	SS7110840SP	4	55	SS8661212TP	12	51
SS6080410SP	2	46	SS7110840SP	8	74	SS8661212TP	32	47
SS6090440SP	44	39	SS7110840SP	10	44	SS9090813TP	40	18
SS6090520SP	14	36	SS7111110TP	10	45	SS9120643TP	44	49
SS6090520SP	18	35	SS7111120TP	32	64	SS9120643TP	46	49
SS6090670TP	8	71	SS7111120TP	34	64	SS9120910TP	40	1
SS6090810TP	8	73	SS7111410TP	8	79	SS9151210TP	16	62
SS6092120SP	44	40	SS7120640SP	2	50	SS9661230CP	6	37
SS6110610TP	26	48	SS7120640SP	4	50	ST4031021SR	58	23
SS6110610TP	38	48	SS7120710SP	26	52	SV4030801SS	56	34
SS6110640SP	26	49	SS7120910SP	14	41	SV4030801SS	58	22
SS6110820TP	8	72	SS7150910TP	26	53	SV4031006SR	58	9
SS6111052TP	36	43	SS7150910TP	36	45	TA0750404R0	12	52
SS6111210SP	6	8	SS7150940SP	38	55	TA1050504R0	4	53
SS6120940SP	4	58	SS7151120SP	8	75	TA1050504R0	38	49
SS6120940SP	22	34	SS7151120SP	10	46	TA1250406R0	34	53
SS6120940SP	42	15	SS7151310TP	6	32	TA1330405R0	36	47
SS6121010SP	10	43	SS7740740SP	4	60	TA2050416R0	4	62
SS6121010SP	36	24	SS8080410TP	22	31	TA2100904R0	4	64
SS6121210SP	14	40	SS8080610SP	22	32	WP0371016SD	2	13
SS6121840SP	36	7	SS8090530TP	30	29	WP0371026SD	38	54
SS6123010SP	36	16	SS8090710SP	18	39	WP0450801SD	6	9
SS6151040SP	4	59	SS8110422TP	16	60	WP0450801SD	28	12
SS6151040SP	16	66	SS8110422TP	18	38	WP0450801SD	42	18
SS6151220SP	8	81	SS8110520SP	10	47	WP0450826SC	14	48
SS6151220SP	18	37	SS8120740SP	14	43	WP0450826SC	16	48
SS6151412TP	6	30	SS8150510TP	8	83	WP0480856SP	4	75
SS6151412TP	14	37	SS8150710TP	4	61	WP0482086SD	28	14

NUMERICAL INDEX OF PARTS

PART NO	PAGE	REF NO.
WP0482086SD	42	19
WP0501016SC	30	42
WP0550800SP	14	46
WP0551016SH	30	24
WP0551016SH	44	43
WP0600116KP	18	19
WP0612516SD	14	45
WP0612516SD	18	41
WP0621016SH	18	42
WP0621016SH	36	46
WP0650876SD	18	43
WP0703216SP	4	65
WP0850002SP	4	82
WP0952616SD	10	29
WP0952616SD	34	48
WP1612616SE	48	24
WS0451040KP	30	25
WS0820002KN	50	23
WS0822010KP	16	49
WS1643202KR	48	27
WT0430001KN	54	40
WZ0850302K0	42	17