

# Honeywell

THE S87 IS A LOW VOLTAGE, SOLID STATE, DIRECT SPARK IGNITION CONTROL MODULE FOR GAS-FIRED FURNACES, BOILERS AND HEATING APPLIANCES. MODELS ARE AVAILABLE WITH OR WITHOUT A PREPURGE TIMER. THE S87 CONTROLS THE GAS VALVE, MONITORS THE MAIN BURNER FLAME AND GENERATES A HIGH VOLTAGE FOR SPARK IGNITION.

S87A uses a single electrode for spark ignition and flame sensing. Use only with Honeywell gas controls designed for DSI application: V845, V854, VR845, VR854, VR8450 and VR8540.

S87B uses a single electrode for spark ignition and flame sensing. Use with any gas control designed for DSI application that is rated at 2.0 A or less. Includes optional alarm circuit for use on system safety lockout.

S87C uses separate electrodes for spark ignition and flame sensing. Use only with Honeywell gas controls designed for DSI application: V845, V854, VR845, VR854, VR8450 and VR8540. For direct replacement of S825C. See page 3.

S87D uses separate electrodes for spark ignition and flame sensing. Use with any gas control designed for DSI application that is rated at 2.0 A or less. Includes optional alarm circuit. For direct replacement of S825D. See page 3.

S87J uses a single electrode for spark ignition and flame sensing. Use with any gas control designed for DSI application that is rated at 2.0 A or less. Includes a 30 second (minimum) delay for use with system prepurge.

S87K uses separate electrodes for spark ignition and flame sensing. Use with any gas control designed for DSI application that is rated at 2.0 A or less. Includes a 30 second (minimum) delay for use with system prepurge.

External, replaceable fuse protects system transformer and temperature controller.

Automatic system lockout after trial-for-ignition if malfunction exists or main burner flame fails to ignite. All models available with 4, 6, 11, or 21 second (nominal) lockout time.

Compact, solid state components for accurate, long-lasting performance.

Convenient remote start procedure; after safety shutdown, control module can be reset from the temperature controller.

Low voltage control circuit reduces wiring costs.

Uses flame rectification principle to prove presence of main burner flame; false flame signal resulting from short to ground results in safety shutdown.

## DIRECT SPARK IGNITION CONTROL MODULE

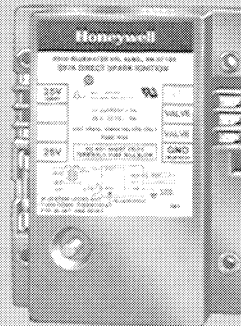

S87A

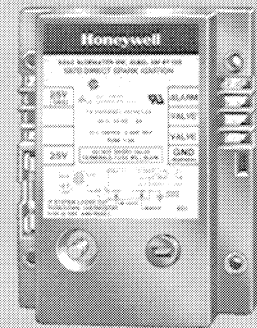

S87D

## S87A,B,C,D,J,K

# SPECIFICATIONS

## IMPORTANT

THE SPECIFICATIONS GIVEN IN THIS PUBLICATION DO NOT INCLUDE NORMAL MANUFACTURING TOLERANCES. THEREFORE, THIS UNIT MAY NOT MATCH THE LISTED SPECIFICATIONS EXACTLY. ALSO, THIS PRODUCT IS TESTED AND CALIBRATED UNDER CLOSELY CONTROLLED CONDITIONS, AND SOME MINOR DIFFERENCES IN PERFORMANCE CAN BE EXPECTED IF THOSE CONDITIONS ARE CHANGED.

The S87 Direct Spark Ignition Control Module controls a Direct Spark Ignition (DSI) gas heating system. A combination gas control spark igniter, flame sensor, thermostat or temperature controller, temperature limit controller and 25 Vac transformer complete the DSI system.

The S87 performs the following functions when the thermostat calls for heat.

1. The S87J and K models provide a 30 second prepurge (delay on start-up).
2. All models check for a false flame condition (short to ground). Module will lock out if false flame condition is present. Reset is manually done from the thermostat.
3. Generates 30,000 volts (open circuit) at the spark-igniter stud for direct ignition of the main burner.
4. Opens the main gas control valve.
5. Senses the presence of main burner flame and discontinues ignition spark. If the burner fails to ignite within the trial-for-ignition period, the S87 goes into safety lockout. Reset is manually done from the thermostat.
6. On a loss of power, the S87 allows the system to shut down safely. Start-up is initiated when power is restored.

7. On a loss of main burner flame, the timed trial-for-ignition is repeated. Safety lockout occurs if flame is not reestablished within the trial-for-ignition period. Reset is manually done from the thermostat.

MODELS: See Table 1.

### ELECTRICAL RATINGS:

- Voltage and Frequency—25 Vac, 60 Hz.
- Current Rating—0.2 A at 25 Vac.
- Valve Contacts (S87B,D,J,K)—2.0 A at 25 Vac.
- Alarm Contacts (S87B,D)—0.5 A at 25 Vac.

THERMOSTAT HEAT ANTICIPATOR SETTING: 0.2 A plus valve current draw.

SAFETY LOCKOUT TIMING: 4, 6, 11, 21 sec (nominal). Specify when ordering.

FLAME FAILURE REIGNITION TIME: 0.8 sec maximum.

FLAME CURRENT SIGNAL REQUIRED: 1.5  $\mu$ A dc minimum. See Table 1 for recommended flame sensors.

# ORDERING INFORMATION

WHEN PURCHASING REPLACEMENT AND MODERNIZATION PRODUCTS FROM YOUR TRADELINE WHOLESALE OR YOUR DISTRIBUTOR, REFER TO THE TRADELINE CATALOG OR PRICE SHEETS FOR COMPLETE ORDERING NUMBER, OR SPECIFY—

1. Order number S87A, B, C, D, J or K.
2. Safety lockout timing (4, 6, 11 or 21 seconds).
3. DSI system controls, as required.
  - a. 25 V, 60 Hz transformer.
  - b. Low voltage thermostat or temperature controller.
  - c. Dual valve combination gas control (for DSI application).
  - d. Spark igniter and flame sensor or combination spark igniter/flame sensor mounted on single bracket.
  - e. Ignition cable.
  - f. High temperature limit controller and auxiliary controls as required.

IF YOU HAVE ADDITIONAL QUESTIONS, NEED FURTHER INFORMATION, OR WOULD LIKE TO COMMENT ON OUR PRODUCTS OR SERVICES, PLEASE WRITE OR PHONE:

1. YOUR LOCAL HONEYWELL RESIDENTIAL SALES OFFICE (CHECK WHITE PAGES OF YOUR PHONE DIRECTORY).
2. RESIDENTIAL DIVISION CUSTOMER SERVICE  
HONEYWELL INC., 1885 DOUGLAS DRIVE NORTH  
MINNEAPOLIS, MINNESOTA 55422-4386 (612)542-7500

IN CANADA—HONEYWELL LIMITED/HONEYWELL LIMITEE, 740 ELLESMERE ROAD, SCARBOROUGH, ONTARIO M1P 2V9. INTERNATIONAL SALES AND SERVICE OFFICES IN ALL PRINCIPAL CITIES OF THE WORLD.

TABLE 1 — S87 MODELS

MODEL NO.	SPARK IGNITER	FLAME SENSOR	VALVE REQUIRED <sup>a</sup>
S87A		Q347B <sup>c</sup>	Honeywell V845, V854, VR845, VR854, VR8450, VR8540
S87B <sup>b,j,f</sup>		Q347B <sup>c</sup>	Any DSI valve rated up to 2.0 A maximum
S87C <sup>d</sup>	Q347A or Q330	(1) Q354A	Honeywell V845, V854, VR845, VR854, VR8450, VR8540
		Q342 <sup>e</sup>	
		Q361 <sup>e</sup>	
S87D <sup>b,d,k,f</sup>	Q347A	Q354A	Any DSI valve rated up to 2.0 A maximum
		Q342 <sup>e</sup>	
		Q361 <sup>e</sup>	

<sup>a</sup>Valve used must be designed for DSI application.

<sup>b</sup>These models have an alarm circuit.

<sup>c</sup>Single electrode for spark ignition and flame sensing.

<sup>d</sup>S87C can be used for direct field replacement of S825A,C. S87D can be used for direct field replacement of S825A-D.

<sup>e</sup>Separate spark igniter and flame sensor mounted on a common bracket.

<sup>f</sup>Includes a 30 second (minimum) prepurge timer.

SPARK GENERATOR VOLTAGE: 30,000 V open circuit.

See Table 1 for spark igniter.

IGNITION CABLE:

Type—See Table 2 below. Maximum length, 3 ft. [0.9 m].

Connectors—snap-spring, 1/4 in. [6.4 mm] diameter.

TABLE 2—RECOMMENDED IGNITION CABLE

CABLE TYPE	RMS VOLTAGE RATING	TEMPERATURE RATING	
		F	C
UL Style 3217	10,000	302	150
UL Style 3257	10,000	482	250

MOUNTING: Mounts in any position. See Fig. 1.

DIMENSIONS: See Fig. 1.

AMBIENT TEMPERATURE RATING: Minus 40 F to plus 175 F [minus 40 C to plus 79 C].

RELATIVE HUMIDITY RATING: 5 to 95 percent at 90 F [32 C].

PREPURGE TIMING (S87J,K): 30 seconds, minimum; 45 seconds, maximum.

WIRING CONNECTIONS: 1/4 in. [6.4 mm] male, quick-connect terminals for system component connections and 1/4 in. [6.4 mm] diameter stud base for ignition cable.

UNDERWRITERS LABORATORIES INC. LISTED: File No. MH11790.

AMERICAN GAS ASSOCIATION CERTIFIED: No. 20-14B.

CANADIAN GAS ASSOCIATION CERTIFIED: No. 1029-ABI-5037A.

REPLACEMENT PART: 3 A fuse.

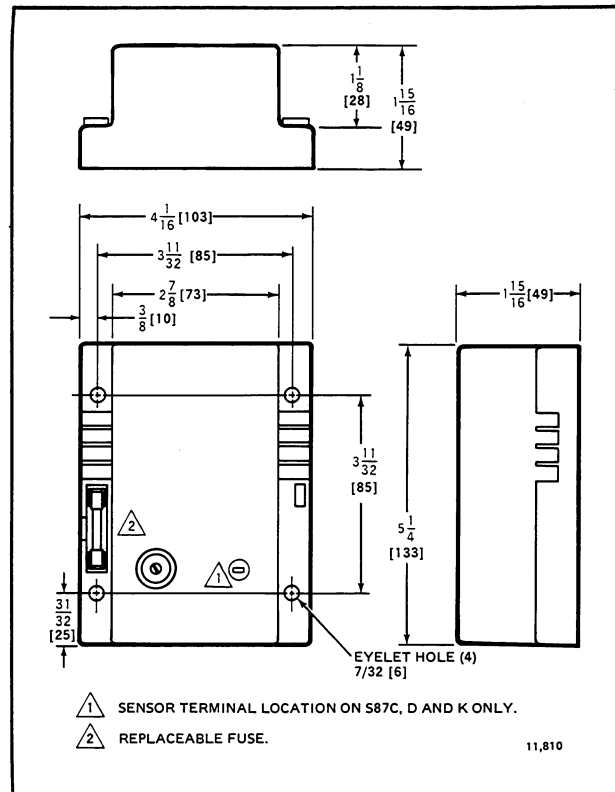

FIG. 1—DIMENSIONS OF S87 IN in. [mm IN BRACKETS].

## INSTALLATION

### WHEN INSTALLING THIS CONTROL MODULE. . .

1. Read these instructions carefully. Failure to follow them could damage the product or cause a hazardous condition.

2. Check the ratings given in the instructions and on the product to make sure it is suitable for your

application.

3. The installer must be a trained, experienced service technician.

4. After installation is complete, check out system operation.

## CAUTION

1. Disconnect power supply before wiring the S87 to prevent electrical shock or equipment damage.
2. If a new gas control is to be installed, turn off gas supply before starting installation. Be sure to conduct a Gas Leak Test after the gas control is installed (follow manufacturer's instructions or see instructions on page 8).

### IMPORTANT

If this is a replacement application, follow the appliance manufacturer's instructions if available. The manufacturer usually provides wiring diagrams, start-up and checkout instructions and service procedures for their system. If the manufacturer's instructions are not available, the information below may be used as a general guide.

## MOUNT THE S87 CONTROL MODULE

Select a location within 3 ft [0.9 m] of the burner that will permit a direct cable route to the spark igniter or igniter/sensor. Ready access to the S87 terminals is necessary for wiring and servicing. Do not exceed the ambient temperature rating given in the SPECIFICATIONS section.

The S87 may be mounted in any position. See Fig. 1 for mounting dimensions. Use No. 6-32 machine screws or No. 8 sheetmetal screws 1 inch long for fastening. Fasten securely.

## MOUNT THE AUXILIARY CONTROLS

Mount the spark igniter, flame sensor, thermostat, transformer, gas control and any other auxiliary controls according to the manufacturer's instructions.

NOTE: S87B, D, and K installations require a transformer rated to handle both the S87 current and gas valve current. Table 3 shows the transformer rating necessary for various valves. S87A, C and J installations require a transformer with a rating of at least 30 VA.

TABLE 3—TRANSFORMER RATINGS FOR S87B, D, K AND DUAL VALVE COMBINATION GAS CONTROL

MINIMUM VA RATING (25 V transformer)	TOTAL VALVE CURRENT (in amperes)	S87B,D,K CURRENT (in amperes)
20	up to 0.6	0.2
30	0.6 to 1.0	0.2
40	1.0 to 1.4	0.2
55	1.4 to 2.0	0.2

## WIRING

### GENERAL PRECAUTIONS

1. Check the wiring diagram furnished by the heating appliance manufacturer, if available, for circuits differing from the ones shown. Carefully follow any special instructions affecting the general procedures outlined below.
2. All wiring must comply with applicable electrical codes and ordinances.
3. Disconnect the power supply before wiring to prevent electrical shock or equipment damage.
4. If installing a separate Q354A flame sensor, the sensor leadwire should be kept as short as possible and should not be allowed to rest against grounded metal surfaces.
5. A common ground is required for the S87, the spark igniter and the main burner. The 25 V (GND) terminal internally grounds one side of the transformer. Any auxiliary controls or limits must not be in the grounded leg.
6. Ignition cable should not touch any metal surface or current-carrying wires. It must not be more than 3 ft [0.9 m] long.
7. Do not short valve terminals as this may burn out the temperature controller, the transformer or the S87 fuse.

## WIRE THE S87 CONTROL MODULE

1. Connect system components to the S87 terminals as shown in the wiring diagrams, Figs. 2-9. Refer to the heating appliance manufacturer's instructions for wiring any other auxiliary controls.

NOTE: Use only recommended ignition cable (see Table 2) to connect the S87 with the spark igniter. Cable must not run in continuous contact with a metal surface or spark voltage will be greatly reduced; use ceramic standoff brackets if necessary. Cable length must not exceed 3 ft [0.9 m].

2. Adjust thermostat heat anticipator to match system current draw. The current draw equals the total current required for the S87 (0.2 A) plus the gas valve and all other 24 V control loads (vent dampers, prepurge relays, etc.). Gas valve must be designed for DSI application.

## GROUNDING S87, SPARK IGNITER AND MAIN BURNER

For the system to operate properly, spark igniter, flame sensor and S87 control module must share a common ground with the main burner. Use thermoplastic insulated wire with a minimum rating of 105 C [221 F] for the ground wire; asbestos insulation is not acceptable. If necessary, use a shield to protect the wire from radiant heat generated by the burner. Connect the ground wire as follows.

1. Fit one end of the ground wire with a female 1/4 in. quick-connect terminal and connect it to the male quick-connect GND (BURNER) terminal on the S87 control module.

2. Strip the other end of the wire and fasten it under the igniter bracket mounting screw. If necessary, use a shield to protect the ground wire from radiant heat. The burner serves as the common grounding area.

NOTE: It is not necessary that the burner is "earth" grounded.

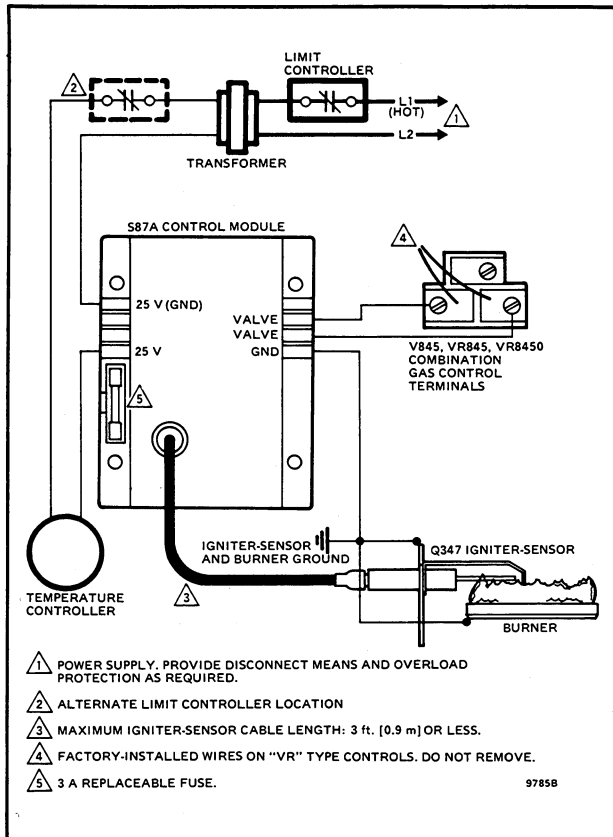

**FIG. 2—S87A IN TYPICAL HOOKUP FOR DIRECT SPARK IGNITION HEATING SYSTEM. SEE FIG. 13 FOR SYSTEM SCHEMATIC DIAGRAM.**

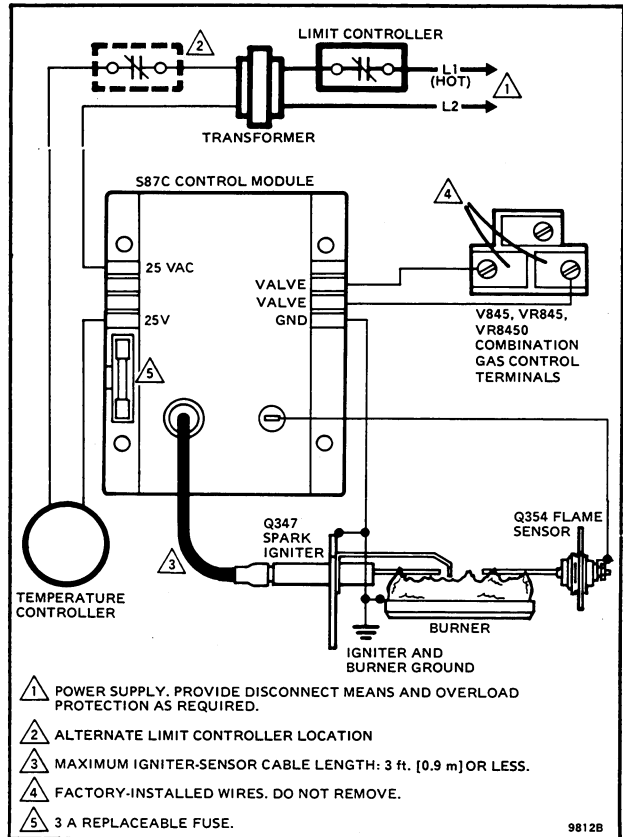

**FIG. 4—S87C IN TYPICAL HOOKUP FOR DIRECT SPARK IGNITION HEATING SYSTEM. SEE FIG. 15 FOR SYSTEM SCHEMATIC DIAGRAM.**

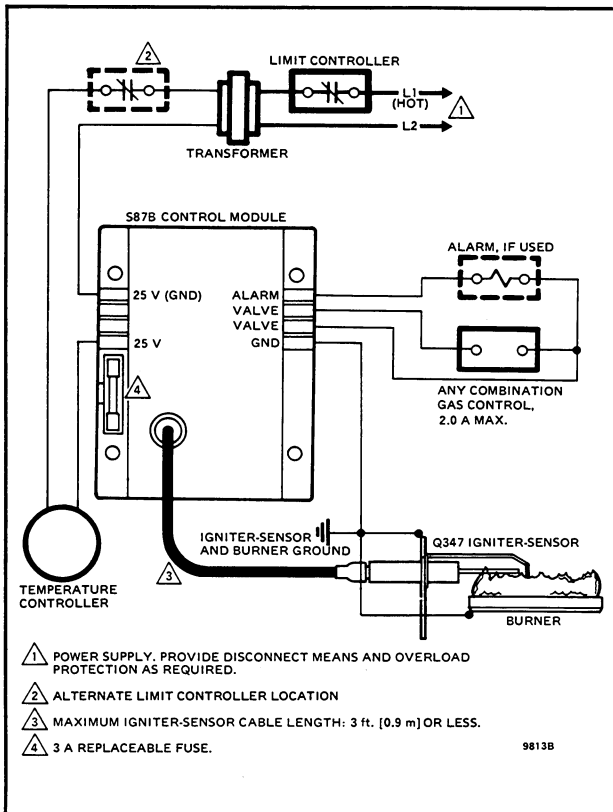

**FIG. 3—S87B IN TYPICAL HOOKUP FOR DIRECT SPARK IGNITION HEATING SYSTEM. SEE FIG. 14 FOR SYSTEM SCHEMATIC DIAGRAM.**

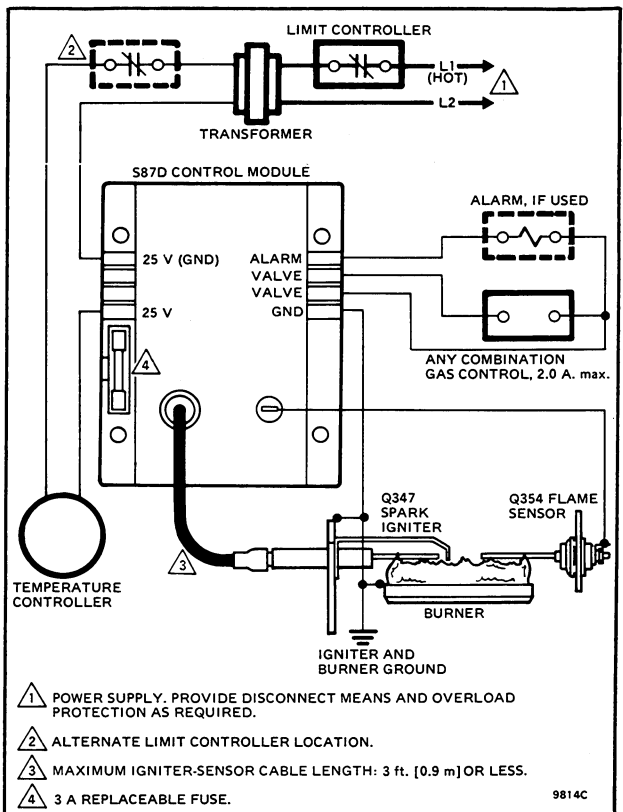

**FIG. 5—S87D IN TYPICAL HOOKUP FOR DIRECT SPARK IGNITION HEATING SYSTEM. SEE FIG. 16 FOR SYSTEM SCHEMATIC DIAGRAM.**

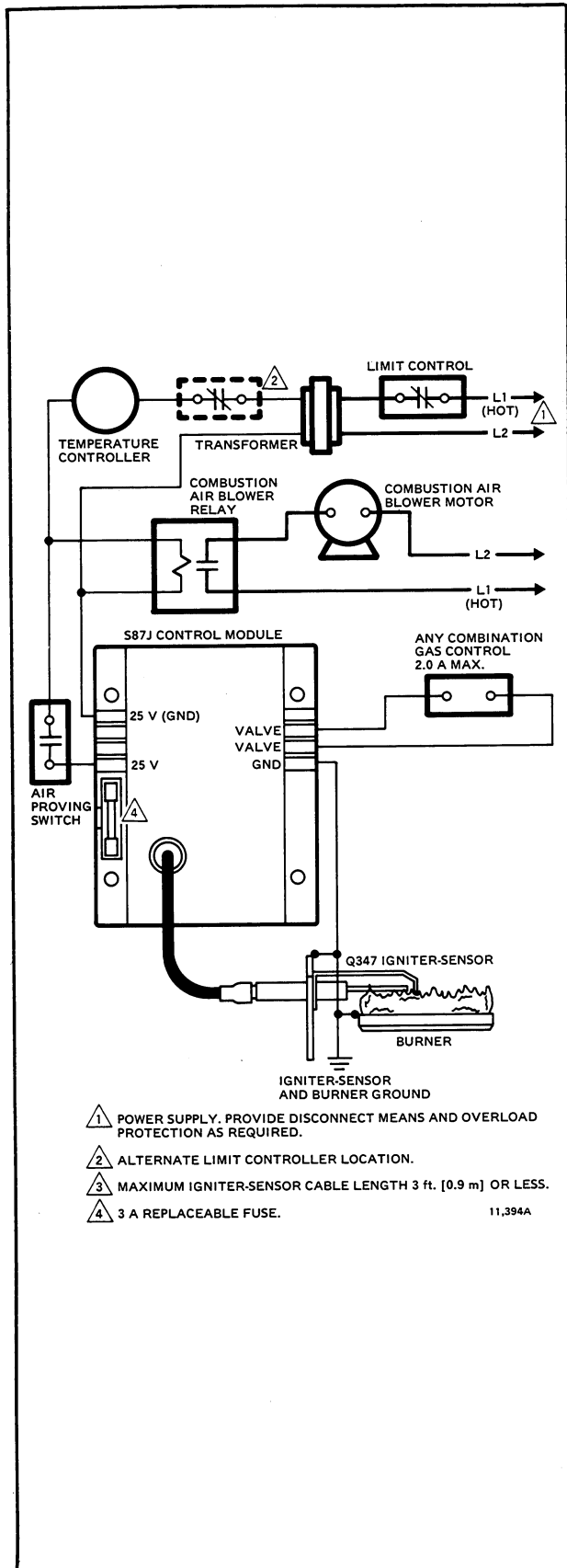

FIG. 6—S87J IN TYPICAL HOOKUP FOR DIRECT SPARK IGNITION HEATING SYSTEM WITH PREPURGE BLOWER CONNECTION. SEE FIG. 17 FOR SYSTEM SCHEMATIC.

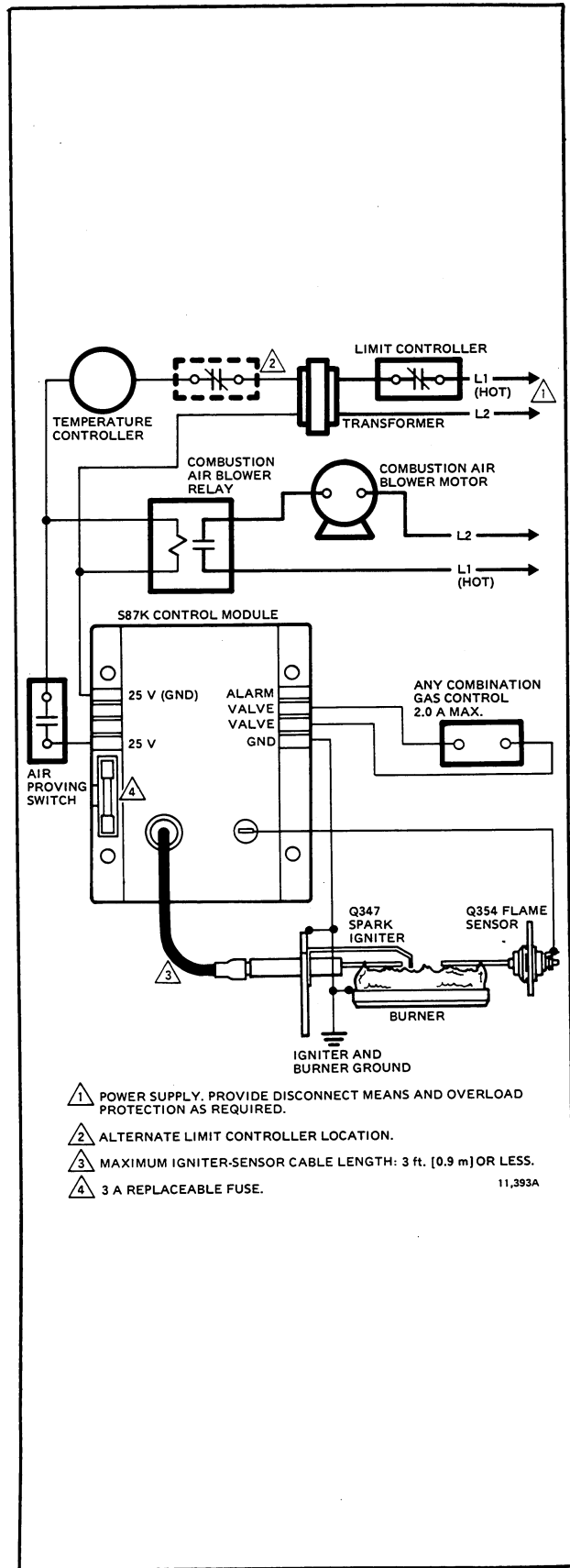

FIG. 7—S87K IN TYPICAL HOOKUP FOR DIRECT SPARK IGNITION HEATING SYSTEM WITH PREPURGE BLOWER CONNECTION. SEE FIG. 18 FOR SYSTEM SCHEMATIC.

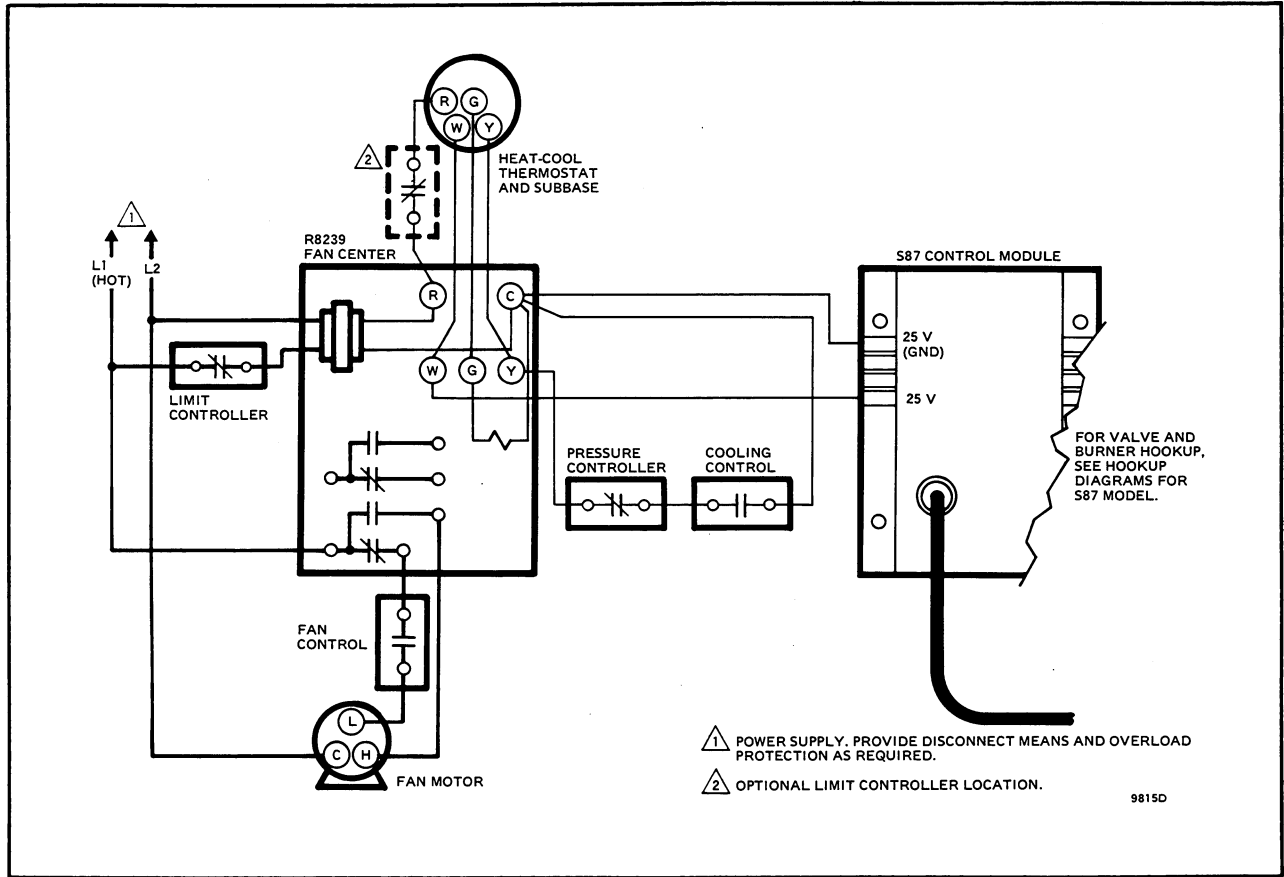

FIG. 8—S87 IN TYPICAL HEAT-COOL APPLICATION WITH DIRECT SPARK IGNITION HEATING SYSTEM.

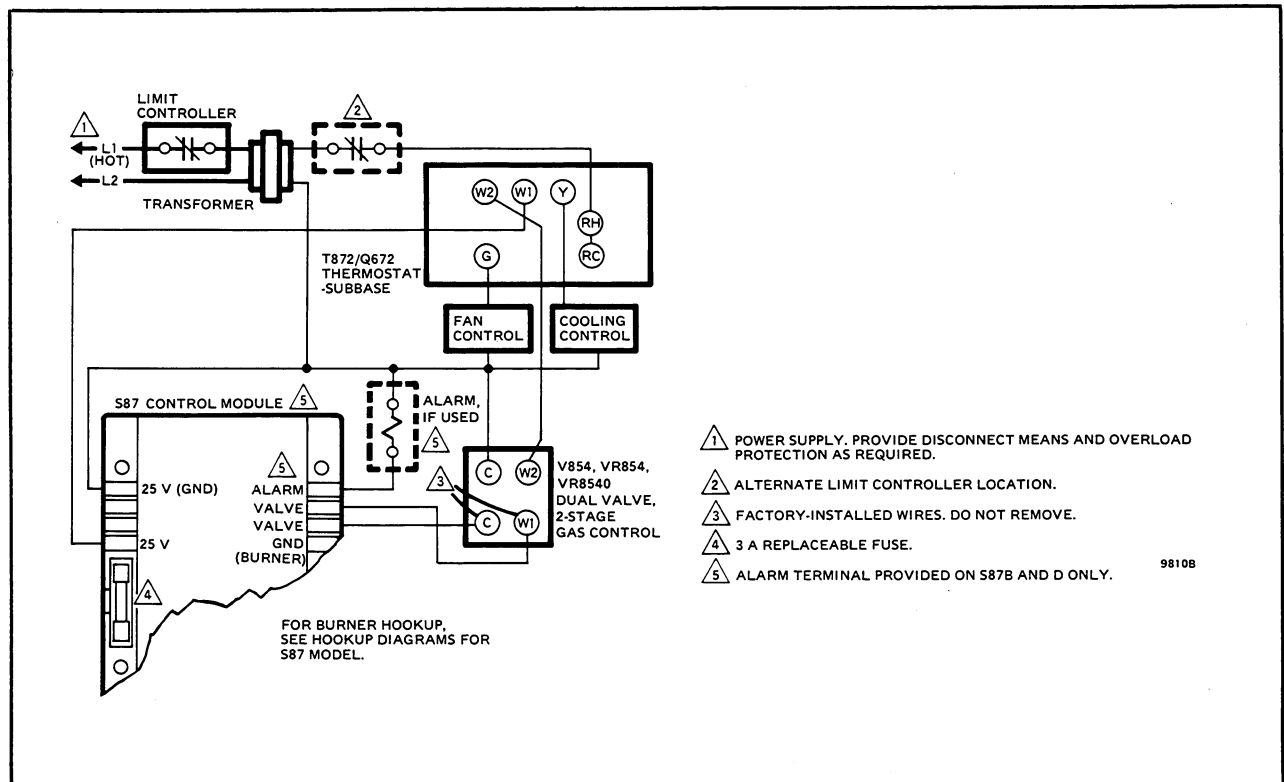

FIG. 9—S87 IN TYPICAL TWO-STAGE DIRECT SPARK IGNITION HEATING SYSTEM.

# STARTUP AND CHECKOUT

The following start-up and checkout procedures are basic to all S87 control modules. If this is a replacement application, refer to the specific instructions provided by the heating appliance manufacturer (if available). Also, since the auxiliary controls used on any DSI system may differ, refer to the manufacturer's instructions for checkout and start-up procedures for other system components.

NOTE: If one of the system components fail, the S87 will either not operate or it will go into safety lockout (depending on the type of failure). If the system does not perform as outlined in START SYSTEM and CHECK SAFETY LOCKOUT steps below, refer to the SERVICE section to determine the cause.

## GAS LEAK TEST

If the gas control has been replaced as part of the S87 installation, perform the following test for gas leaks.

### WARNING

**THE GAS LEAK TEST MUST BE PERFORMED TO AVOID POSSIBLE EXPLOSION OR FIRE.**

With the main burner in operation, paint the pipe joints and valve gasket lines with a rich soap and water solution. Bubbles indicate a gas leak. To stop leak, tighten joints and screws or replace the gasket. Never use a flame to check for gas leaks.

## START SYSTEM

1. Turn on the power and the gas supply.
2. Set thermostat to call for heat and watch for spark at the igniter. (S87J and K models have a 30 second delay on start-up for prepurge.) Time the length of the spark operation; it must be within the lockout timing period (see Table 4).
3. Check that the system starts as follows: Spark turns on, gas valve opens at once, and burner ignites after gas reaches the main burner. Once burner flame is established, spark igniter cuts off.

NOTE: If the gas control has been replaced or serviced, lightoff may not be satisfactory until air has been purged from the gas line or the gas input and combustion air have been adjusted (see manufacturer's instructions).

## CHECK SAFETY LOCKOUT

1. With the system power off and the thermostat set to call for heat, manually shut off the gas supply.
2. Turn power on to energize the S87 and begin spark ignition, immediately start timing.
3. Determine the number of seconds to safety lockout (spark cutoff). It should not exceed the time shown in Table 4.

TABLE 4—S87 LOCKOUT TIMES

SPECIFIED S87 LOCKOUT TIME (stamped on S87 control module)	SAFETY LOCKOUT TIME SHOULD NOT EXCEED—
4.0 sec.	5.0 sec.
6.0 sec.	7.0 sec.
11.0 sec.	15.0 sec.
21.0 sec.	35.0 sec.

4. After spark cutoff, manually reopen gas supply cock. No gas should flow to the main burner.
5. Reset system as described below.

## RESET S87 AFTER SAFETY LOCKOUT

If the control goes into safety lockout, it will remain locked out until the system is reset.

To reset the system, adjust the thermostat setting below room temperature, wait 30 seconds, and move the thermostat setting up to call for heat. Normal ignition should occur as described in START SYSTEM, above.

## CHECKOUT

Start system and observe operation through at least one complete cycle to make certain all controls are operating safely.

# OPERATION

The S87 control module performs the following basic functions:

- Provides a 30 second (minimum) system prepurge—S87J and K models only.
- Supplies power to the electronic pulse-generator circuit for the spark igniter (30,000 volts, open circuit).
- Allows up to 35 seconds (maximum) for ignition before system safety lockout occurs (see Table 4).
- Senses the burner flame for safe lighting.
- Shuts off spark after burner is lit.

The S87 is powered by a 25 V transformer and activated when the thermostat calls for heat. Operation is as follows (refer to Fig. 10).

On every call for heat (system start), the S87J and K will delay start-up to provide a 30 second (minimum) system prepurge. After 30 seconds, the operation is the same as all other S87 models.

When the S87 is activated by a thermostat call for heat, an internal transformer provides power to the electronic generator circuit for spark ignition and the safety lockout timing begins. At the same time, the S87 opens the gas control's main valves which allows gas to flow to the main burner.



Power is supplied to the spark generator until:

- the main burner lights and flame sensor current reaches 1.5  $\mu\text{A}$ , or
- the safety lockout timing period ends.

If the main burner lights, a flame sensing circuit is completed through the flame to the burner head to ground. This current flow sets the safety lockout timer to the reset (normal) condition and interrupts the spark ignition circuit. Should the current flow be interrupted; i.e., flame-out condition, the trial-for-ignition begins again.

The S87 will keep the gas control main valve open as long as there is a call for heat and current through the

flame sensing circuit. If, however, the safety lockout timing period ends before the main burner lights or the flame sensor establishes enough current, the system will go into safety lockout.

When the system goes into safety lockout, power to the spark generator is interrupted, the gas control circuit is interrupted and the alarm circuit (S87B and D only) is completed. The system will stay locked out until it is reset by moving the thermostat set point below room temperature, no call for heat, for 30 seconds. Then, re-energize the system by moving the thermostat set point 5 F [3 C] above room temperature.

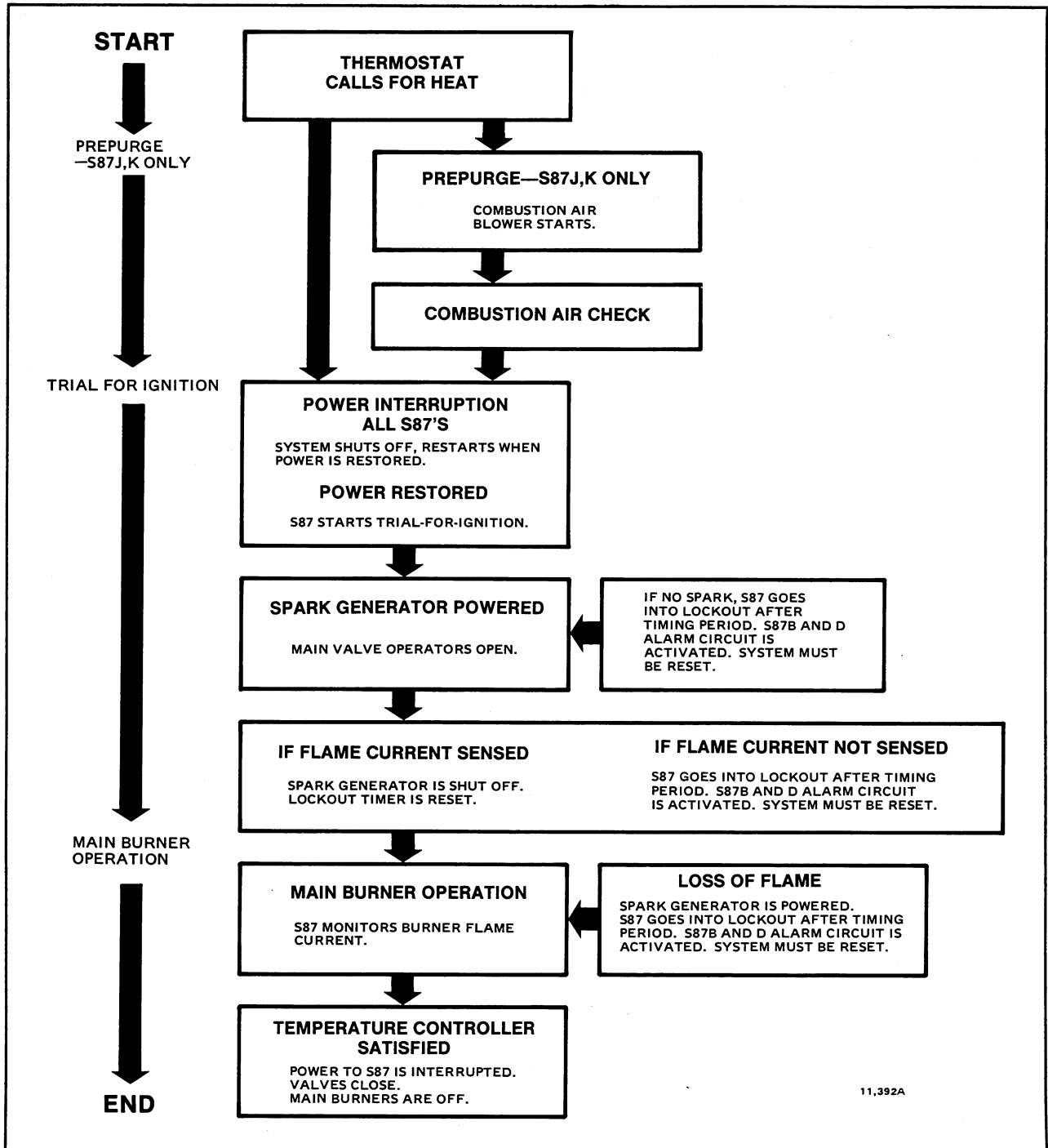

FIG. 10—NORMAL SYSTEM SEQUENCE OF OPERATION.

# SERVICE

## IMPORTANT

1. Only persons trained and experienced in DSI systems should service this equipment.
2. If a condition exists that causes the S87 control module to go into safety lockout, meter readings must be taken quickly after restart—within trial-for-ignition period.
3. Always de-energize the system for at least 30 seconds before recycling for further tests.
4. Always turn off gas supply before performing ignition checks.
5. S87 control module cannot be repaired. If the troubleshooting procedure indicates a malfunction in the S87, it must be replaced.
6. The following service procedures are for the S87 and basic DSI systems. On all installations, refer to the appliance manufacturer's service instructions.

## PRELIMINARY CHECK

The following checks should be made before troubleshooting the system.

1. Check for power to the heating appliance and the S87. Voltage to S87 should be between 20.5 and 28.5 Vac.
2. Check fuse on S87 control module and replace if blown.
3. Make certain that the manual shutoff valve in the supply line and the gas cock knob on the combination gas control valve are open.
4. Make certain that all wiring connections are clean and tight.
5. Make certain the S87 is not in safety lockout. De-energize the system by moving the thermostat set point below room temperature. Wait at least 30 seconds and reenergize the system by moving the thermostat set point 5 F [3 C] above room temperature. Return set point to normal temperature setting.
6. Check ceramic insulator on flame sensor, spark igniter or igniter/sensor. A cracked insulator will allow current to leak to ground. Replace device if insulator is cracked.
7. Check the flame sensor and its mounting bracket. Correct the position if bent out of shape.
8. Review the S87 normal sequence of operation. See START SYSTEM section.

## S87 COMPONENT CHECKS

### SPARK IGNITION CIRCUIT

The step-up transformer in the S87 provides spark ignition at 30,000 volts (open circuit). To check the spark ignition circuit, proceed as follows.

1. Shut off gas supply to the gas control.
2. Disconnect the ignition cable at the S87 stud terminal to isolate the circuit from the spark igniter or igniter/sensor. Prepare a short jumper lead, using heavily insulated wire such as ignition cable.

## CAUTION

In the next step, DO NOT allow fingers to touch either the stripped end of the jumper or the stud terminal. This is a very high voltage circuit and electrical shock can result.

3. Perform this test immediately upon energizing the system — before the S87 goes into safety lockout and interrupts the spark circuit. Touch one end of the jumper firmly to the S87 GND terminal. (DO NOT remove the existing ground lead.) Slowly move the other end of the jumper wire toward the stud terminal on the S87 to establish a spark. Pull the wire away from the stud and note the length of gap at which spark discontinues.

4. A spark length of 1/8 inch [3 mm] or more indicates satisfactory voltage output. If no arc can be established or the maximum spark is less than 1/8 in. [3 mm], and power to the S87 input terminals was proved, replace the S87.

### IGNITION CABLE

Check the electrical continuity of the ignition cable and make certain the cable is not in contact with metal surfaces. The total cable length should not exceed 3 ft [0.9 m]. A loose connection to the spark igniter or igniter/sensor may not conduct a flame signal even though spark ignition is satisfactory. Check connections to the stud terminal on the S87 and the boot connection to the igniter/sensor. Make certain they are clean and tight.

### GROUNDING CONNECTIONS

A common ground is required for the burner, spark igniter or igniter/sensor mounting bracket and the GND (burner) terminal of the S87. If ground is poor or erratic, safety shutdown may occur occasionally even though operation is normal at time of checkout. Therefore, if nuisance shutdowns have been reported, be sure to check ground connections.

Electrical ground connections at the spark igniter or igniter/sensor and the S87 must be clean and tight. If leadwire is damaged or deteriorated, use only No. 14 or No. 18 gauge, moisture-resistant, thermoplastic insulated wire with 105 C [221 F] minimum rating as replacement.

### FLAME SENSOR CIRCUIT

The S87 provides ac power to the igniter/sensor (on S87A, B and J) or the flame sensor (on S87C, D and K) which the burner flame rectifies to direct current. If the flame signal back to the S87 is less than 1.5  $\mu$ A dc, the system will lock out.

The output of the flame sensing circuit cannot be checked directly on the S87. Check the flame sensing circuit directly by checking the flame sensing current from the sensor to the S87 as follows.

1. Connect a meter (dc microammeter scale) in series with the flame signal ground wire as shown in Fig. 11. Use the Honeywell W136A Test Meter or equivalent. Disconnect the ground wire at the S87. Connect the red (positive) meter lead to the free end of the ground wire. Connect the black (negative) meter lead to the quick-connect ground terminal on the S87.

2. Restart the system and read the meter. The flame sensor current must be at least  $1.5 \mu\text{A}$  and steady. If the reading is less than  $1.5 \mu\text{A}$  or unsteady, see LOW OR UNSTEADY FLAME CURRENT section, below.

If a flame is present at sensor and a reading of  $0 \mu\text{A}$  is obtained, check for a secondary ground connection to the 25 V (GND) terminal. If secondary connection exists, temporarily remove connection and measure flame current.

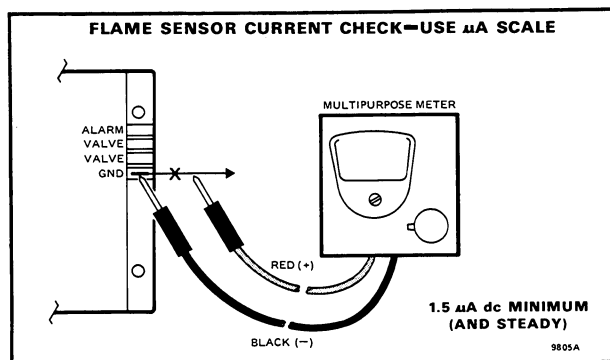

FIG. 11—S87 FLAME CURRENT MEASUREMENT.

## LOW OR UNSTEADY FLAME CURRENT

If the current to the S87 flame circuit is less than  $1.5 \mu\text{A}$  or is unsteady—check the burner flame, flame sensor location and electrical connections as follows.

### Burner Flame

The flame sensor must be constantly immersed in flame. Check burner flame conditions as shown in Fig. 12.

### Flame Sensor

The flame signal is best when about 1 in. [25 mm] of flame rod is immersed in the burner flame. A bent flame rod, bent mounting bracket or cracked ceramic insulator can affect flame signal. Replace flame sensor if necessary.

### Electrical Connections and Shorts

Connections at the flame sensor must be clean and tight. If wiring needs replacement, use moisture-resistant No. 18 wire rated for continuous duty up to 105 C [221 F].

## CHECKOUT AFTER SERVICE

Perform the following steps before leaving the job (described in CHECKOUT section)—

- START SYSTEM
- SAFETY LOCKOUT CHECK
- SAFETY LOCKOUT RESET

Also perform any other checks recommended by the heating appliance manufacturer if system components other than the S87 were serviced.

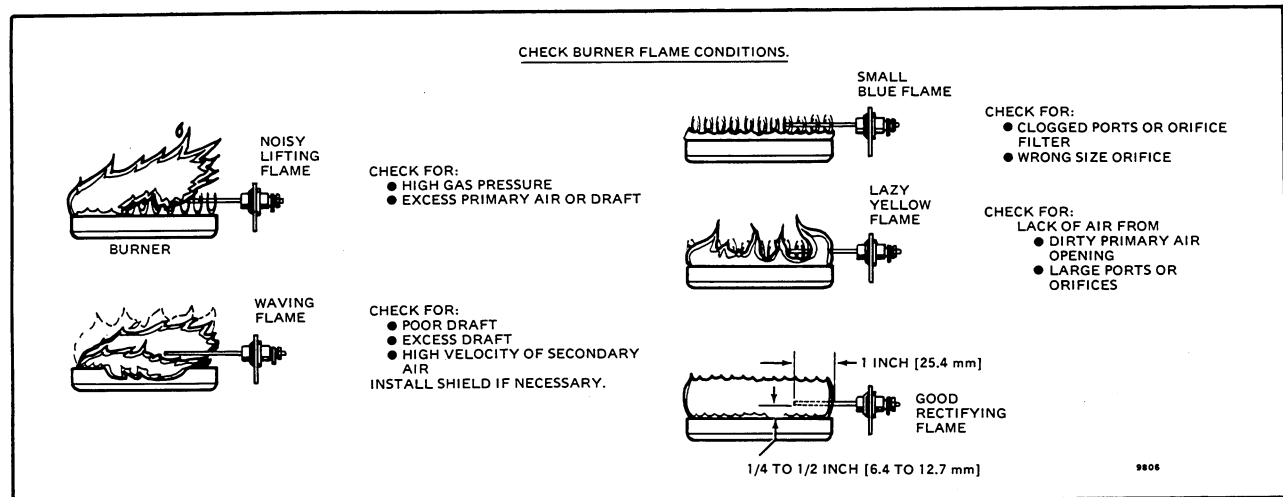

FIG. 12—CHECK BURNER FLAME CONDITIONS.

# TROUBLESHOOTING

Start the system by setting the thermostat (temperature controller) to call for heat. Observe the system response and establish the type of malfunction or deviation from normal operation by using Table 5.

Use Table 5 by following the instructions in the boxes. If the condition is true or okay (answer is yes),

go down to the next box. If the condition is not true or not okay (answer is no), go the box at right. Continue checking and answering conditions in each box until a problem and/or repair is explained. After any maintenance or repair, the troubleshooting sequence should be repeated until normal system operation is obtained.

TABLE 5—S87 DIRECT SPARK IGNITION SYSTEM

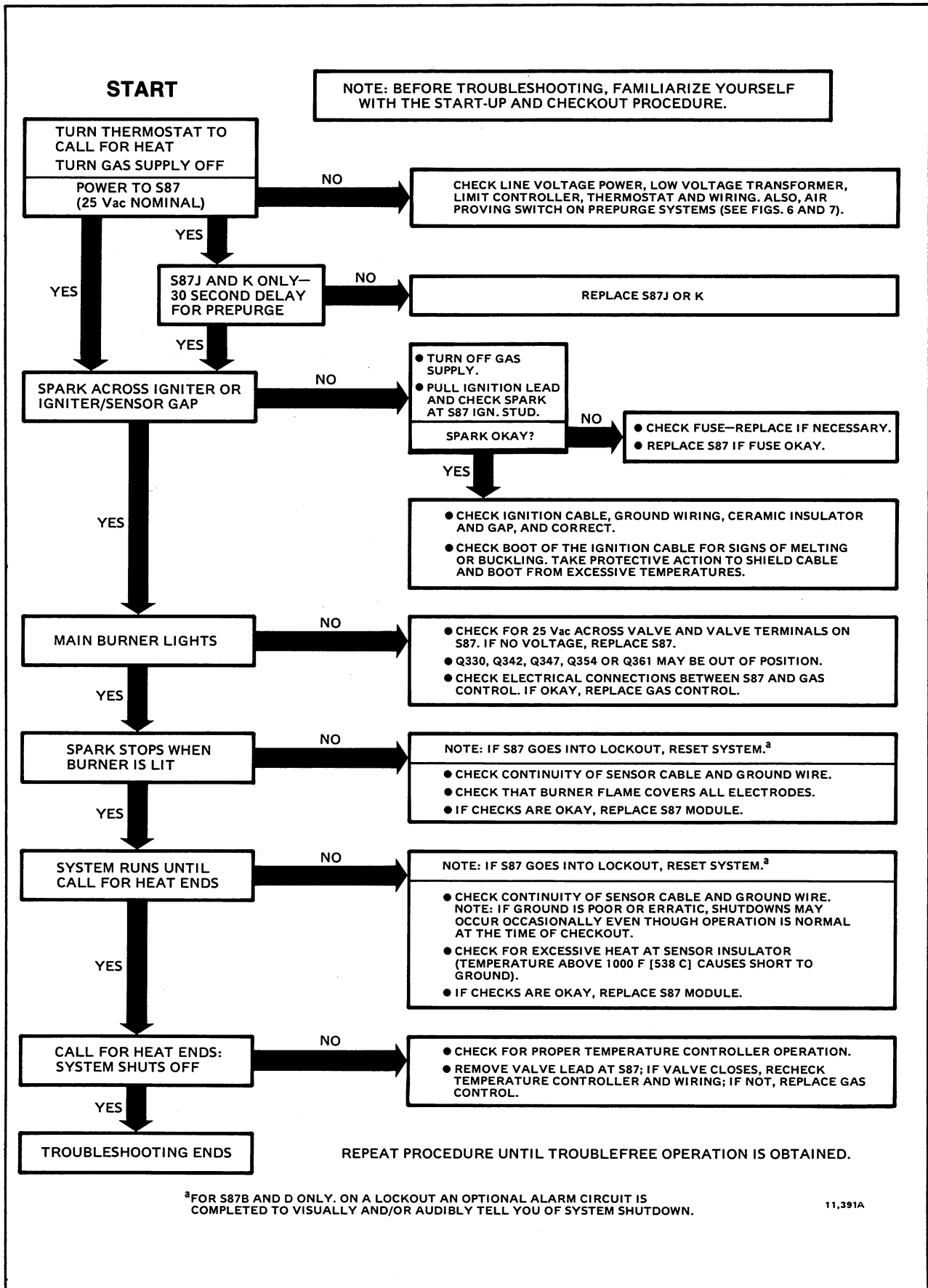

S87 SCHEMATIC DIAGRAMS

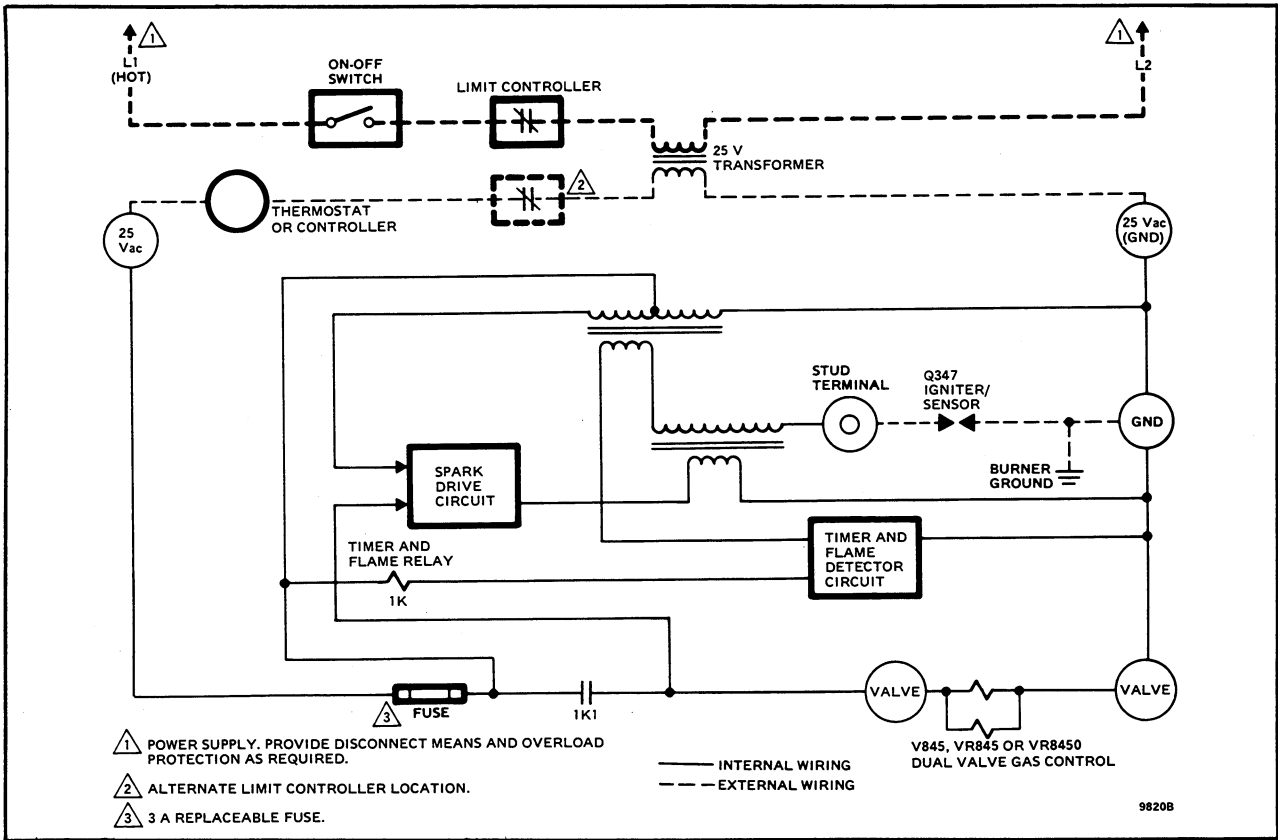

FIG 13—S87A SIMPLIFIED SYSTEM SCHEMATIC.

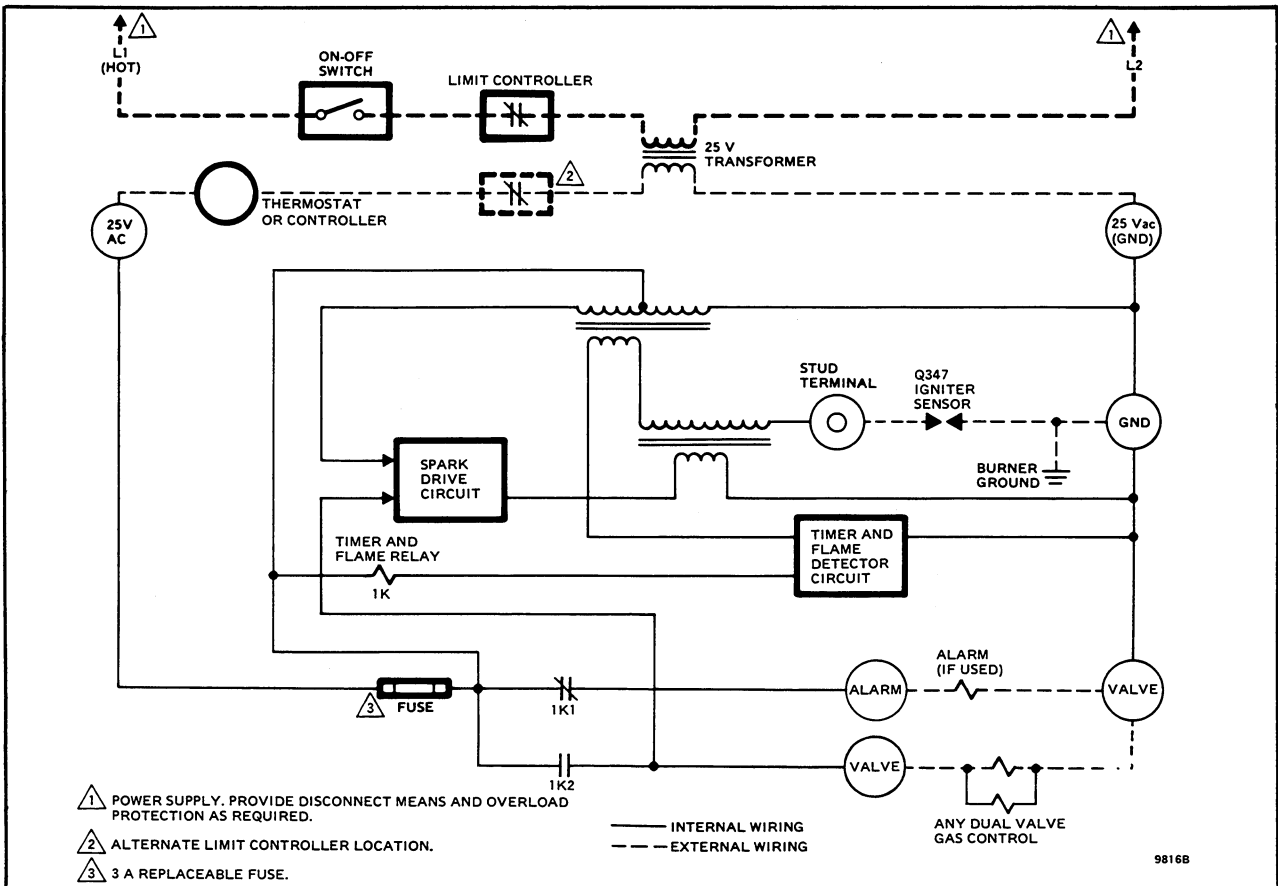

FIG. 14—S87B SIMPLIFIED SYSTEM SCHEMATIC.

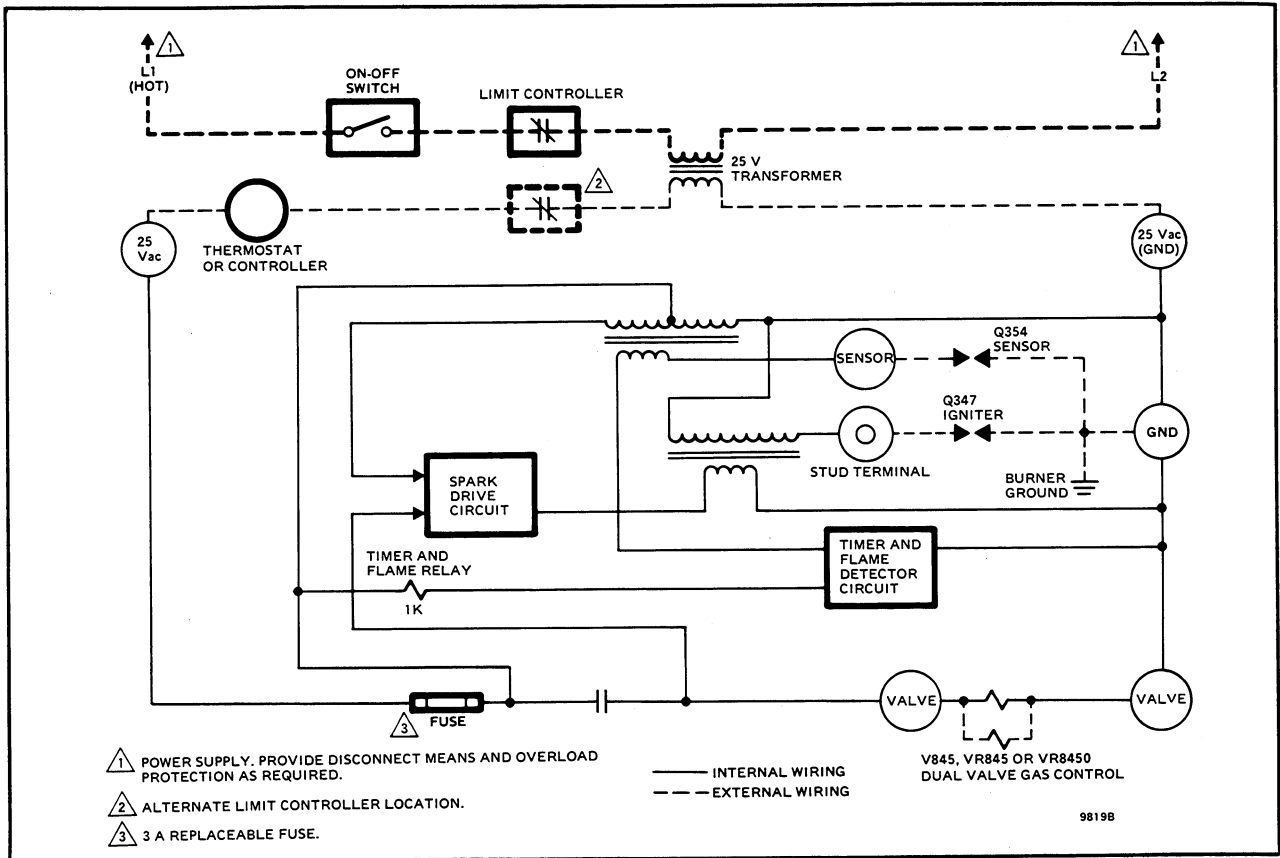

FIG. 15—S87C SIMPLIFIED SYSTEM SCHEMATIC.

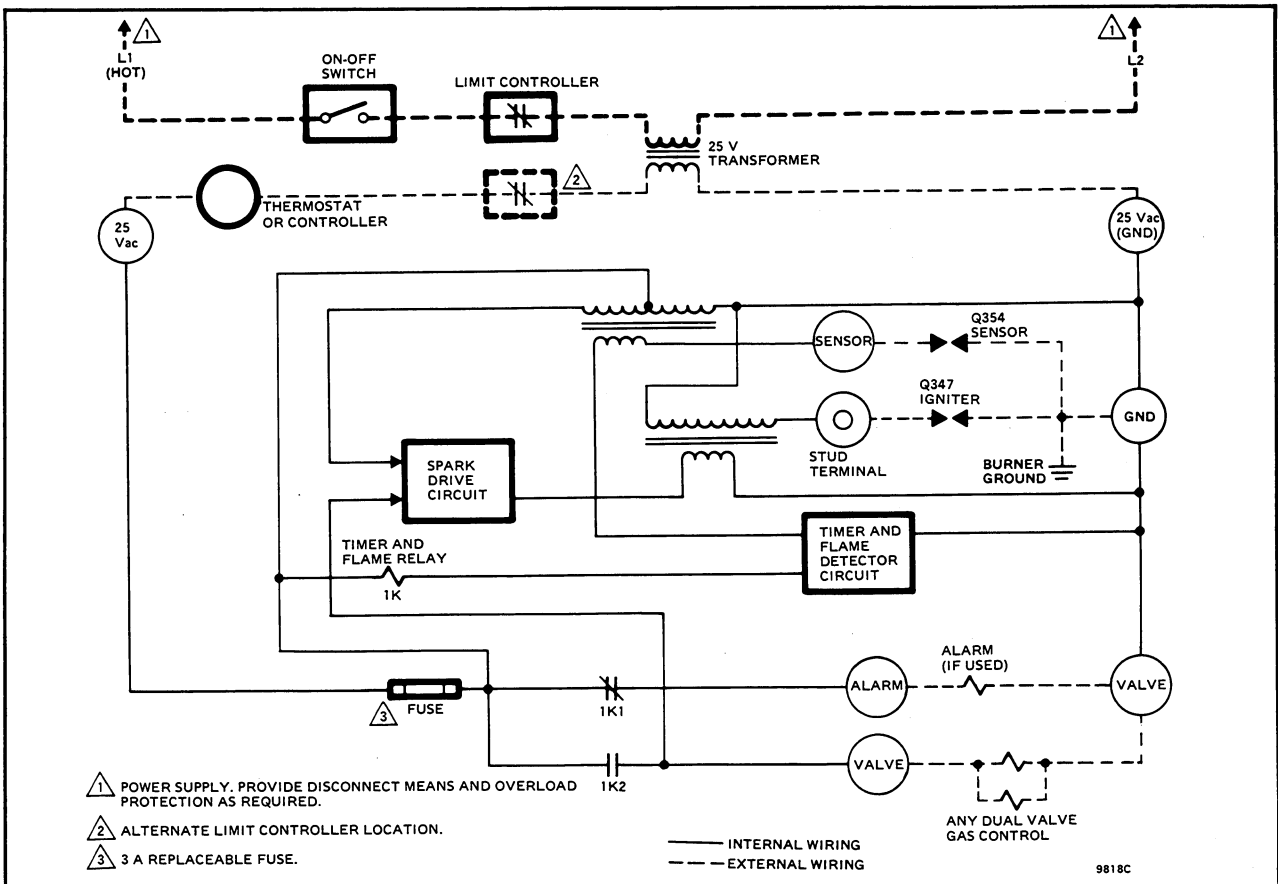

FIG. 16—S87D SIMPLIFIED SYSTEM SCHEMATIC.

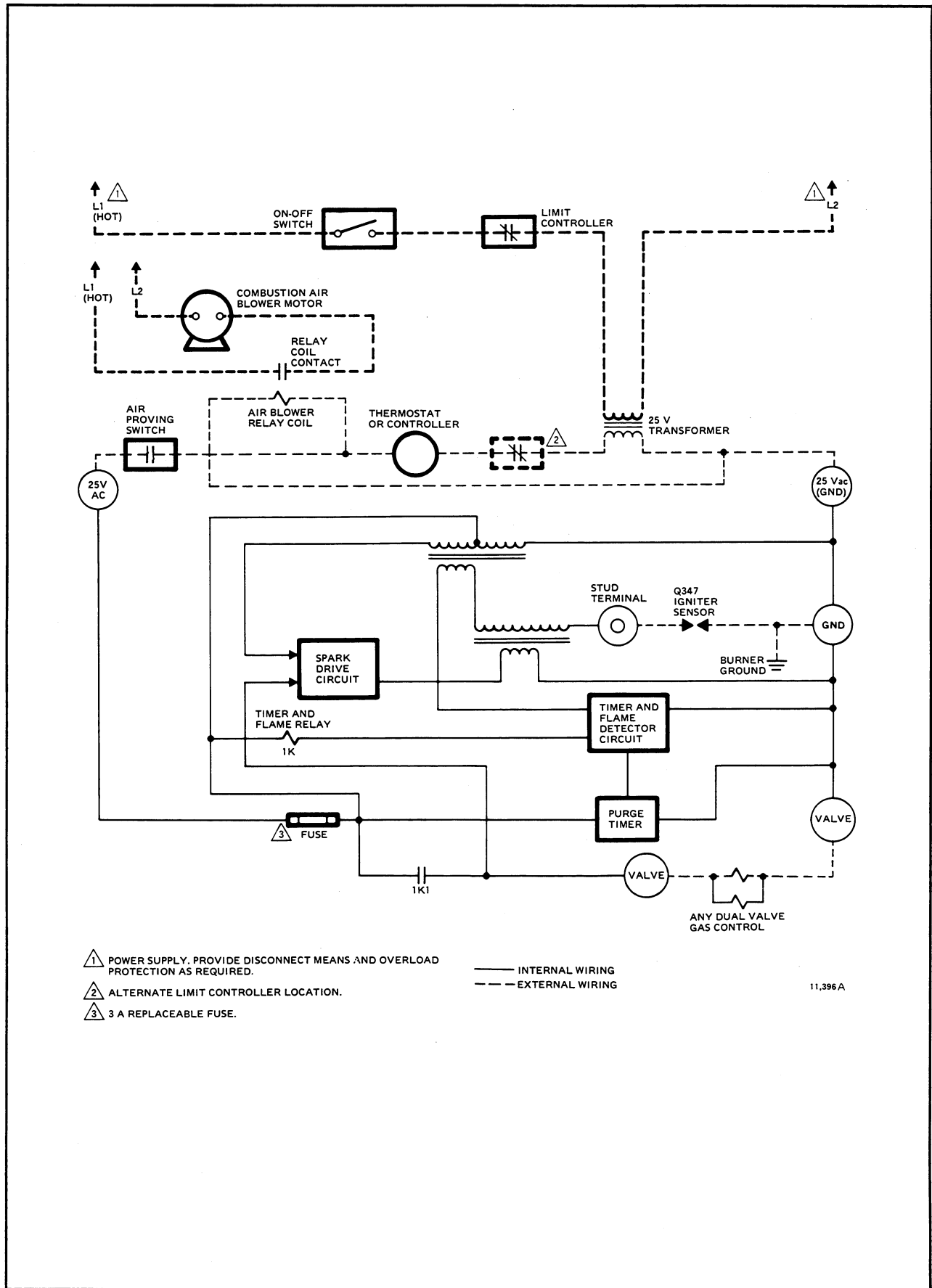

FIG. 17—S87J SIMPLIFIED SYSTEM SCHEMATIC.

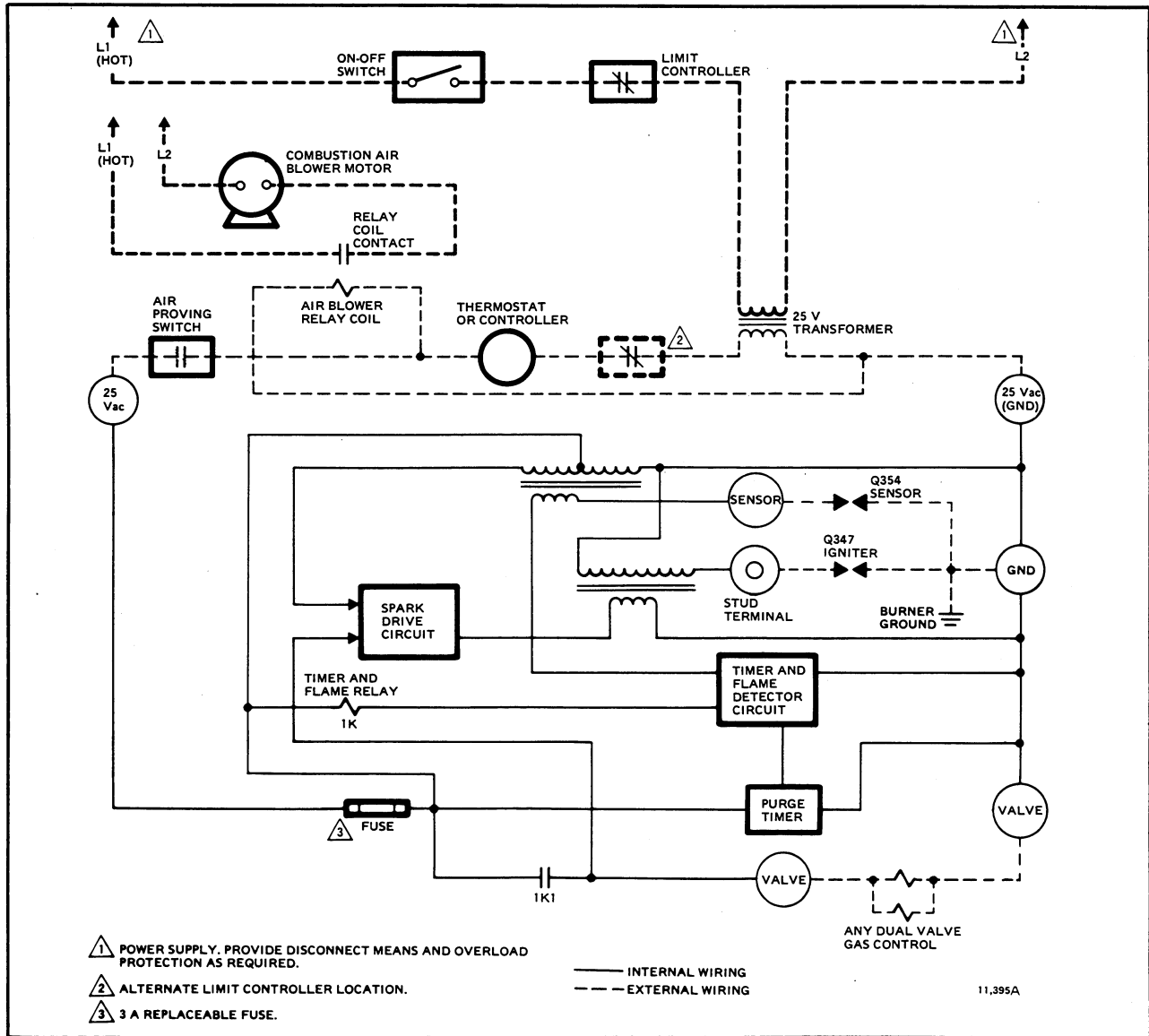

FIG. 18—S87K SIMPLIFIED SYSTEM SCHEMATIC.

## REPLACING S825 WITH S87

### WARNING

The replacement S87 must have the same lock-out timing as the old control to avoid possible explosion and fire hazard.

### CAUTION

Disconnect power to prevent electrical shock or equipment damage.

1. Choose the replacement S87. The replacement must have the same lockout timing as the old control.

TO REPLACE	USE
S825A	S87C or D
S825B	S87D
S825C	S87C or D
S825D	S87D

2. Disconnect the ignition cable and the sensor wire from the S825.

3. Disconnect the leads from the quick-connect terminals on the S825, marking each lead with the S825 terminal name as you remove it.

4. Remove the set aside the S825 module.

5. Mount the S87 in the same location as the S825. Use No. 6-32 machine screws or No. 8 sheetmetal screws 1 inch long. Fasten securely.

6. Check the wires and ignition cable. Replace any wires that appear cracked or damaged.

7. Make sure the system is firmly grounded to the burner. A screw is provided on most burners to simplify



grounding. If you are uncertain of the existing ground, simply run a wire from the GND (BURNER) terminal on the S87 to the burner ground screw and attach it firmly. More than one ground will not hurt. Earth ground is not required with S87.

8. Connect the ignition cable and the sensor wire to the S87.

9. Wire the S87 using the appropriate cross reference chart below. The gas control and the thermostat must be powered from the same transformer when the S87 is used. Some S825 systems had two transformers; in this type of system, rewire to use only one transformer with minimum 40 VA load rating.

#### CONVERSION FROM S825A TO S87C,D

LEAD FROM S825A TERMINAL	CONNECT TO S87C,D TERMINAL <sup>a</sup>
5	VALVE (upper)
3	VALVE (lower)
T2	25 V (GND)
24 V-T1	25 V
GND	GND (BURNER)

<sup>a</sup>The ALARM terminal on S87D is not used in this application.

#### CONVERSION FROM S825B TO S87D

LEAD FROM S825B TERMINAL	CONNECT TO S87D TERMINAL
4	ALARM
5	VALVE (upper)
3	VALVE (lower)
T2	25 V (GND)
24 V-T1	25 V
GND	GND (BURNER)

#### CONVERSION FROM S825C TO S87C,D SINGLE-STAGE OR TWO-STAGE SYSTEM

LEAD FROM S825C TERMINAL	CONNECT TO S87C,D TERMINAL <sup>c</sup>
VALVE-5	VALVE (upper)
VALVE-3	VALVE (lower)
GRD/T2 <sup>a,b</sup>	25 V (GND)
T1 or 24 V-T1 <sup>b</sup>	25 V

<sup>a</sup>Some S825C models have a terminal labeled GND and one labeled T2. On these models, connect T2 and GND from S825 to 25 V (GND) and GND (BURNER), respectively, on S87.

<sup>b</sup>If a second gas valve is connected between GRD/T2 and 24 V-T1, move the 24 V-T1 lead to VALVE (upper) and the GRD/T2 lead to VALVE (lower). The two valves will now be connected in parallel.

<sup>c</sup>The ALARM terminal on S87D is not used in this application.

#### CONVERSION FROM S825D WITH SINGLE VALVE AND ONE TRANSFORMER TO S87D

1. Disconnect gas control from transformer and connect to upper S87 terminal labeled VALVE. Make sure other controls are still connected to transformer.

2. Remove and discard lead that was connected to S825 terminal 5.

3. Make remaining wiring changes:

LEAD FROM S825D TERMINAL	CONNECT TO S87D TERMINAL
4	ALARM
3	VALVE (lower)
GRD/T2 <sup>a</sup>	25 V (GND)
T1 or 24V-T1	25 V

<sup>a</sup>Some S825 models have a terminal labeled GND and one labeled T2. On these models, connect T2 and GND from S825 to 25 V (GND) and GND (BURNER), respectively, on S87.

#### CONVERSION FROM S825D WITH TWO TRANSFORMERS AND TWO GAS CONTROLS TO S87D

1. Disconnect gas controls and alarm relay (if used) from transformer.

2. Connect alarm relay and temperature controls to one transformer with minimum 40 VA load rating. Remove other transformer.

3. Connect gas control transformer lead to upper S87D terminal labeled VALVE.

4. Remove and discard lead that was connected to S825 terminal 5.

5. Make remaining wiring changes:

LEAD FROM S825D TERMINAL	CONNECT TO S87D TERMINAL
4	ALARM
3	VALVE (lower)
GRD/T2 <sup>a</sup>	25 V (GND)
T1 or 24 V-T1	25 V

<sup>a</sup>Some S825 models have a terminal labeled GND and one labeled T2. On these models, connect T2 and GND from S825 to 25 V (GND) and GND (BURNER), respectively, on S87.

#### CONVERSION FROM S825D WITH DUAL VALVE GAS CONTROL AND SINGLE TRANSFORMER TO S87D

1. Disconnect gas control TH lead from transformer and connect to upper VALVE terminal on S87D. Make sure other controls are still connected to transformer.

2. Remove and discard lead that was connected to S825 terminal 5.

3. Make remaining wiring connections:

LEAD FROM S825D TERMINAL	CONNECT TO S87D TERMINAL
4	ALARM
3	VALVE (lower)
GRD/T2 <sup>a</sup>	25 V (GND)
T1 or 24 V-T1	25 V

<sup>a</sup>Some S825 models have a terminal labeled GND and one labeled T2. On these models, connect T2 and GND from S825 to 25 V (GND) and GND (BURNER), respectively, on S87.

**CONVERSION FROM S825D IN TWO-STAGE BURNER SYSTEM WITH TWO GAS VALVES TO S87D**

1. Disconnect transformer powering gas controls and S825D. Make sure remaining transformer has at least 40 VA load rating.

2. Remove and discard lead that was connected to S825 terminal 5.

3. Connect lead that was between second gas control and transformer to upper VALVE terminal on S87.

4. Make remaining wiring connections:

<b>LEAD FROM S825D TERMINAL</b>	<b>CONNECT TO S87D TERMINAL</b>
4	ALARM
3	VALVE (lower)
GRD/T2 <sup>a</sup>	25 V (GND)
T1 or 24 V-T1	25 V

<sup>a</sup>Some S825 models have a terminal labeled GND and one labeled T2. On these models, connect T2 and GND from S825 to 25 V (GND) and GND (BURNER), respectively, on S87.



