

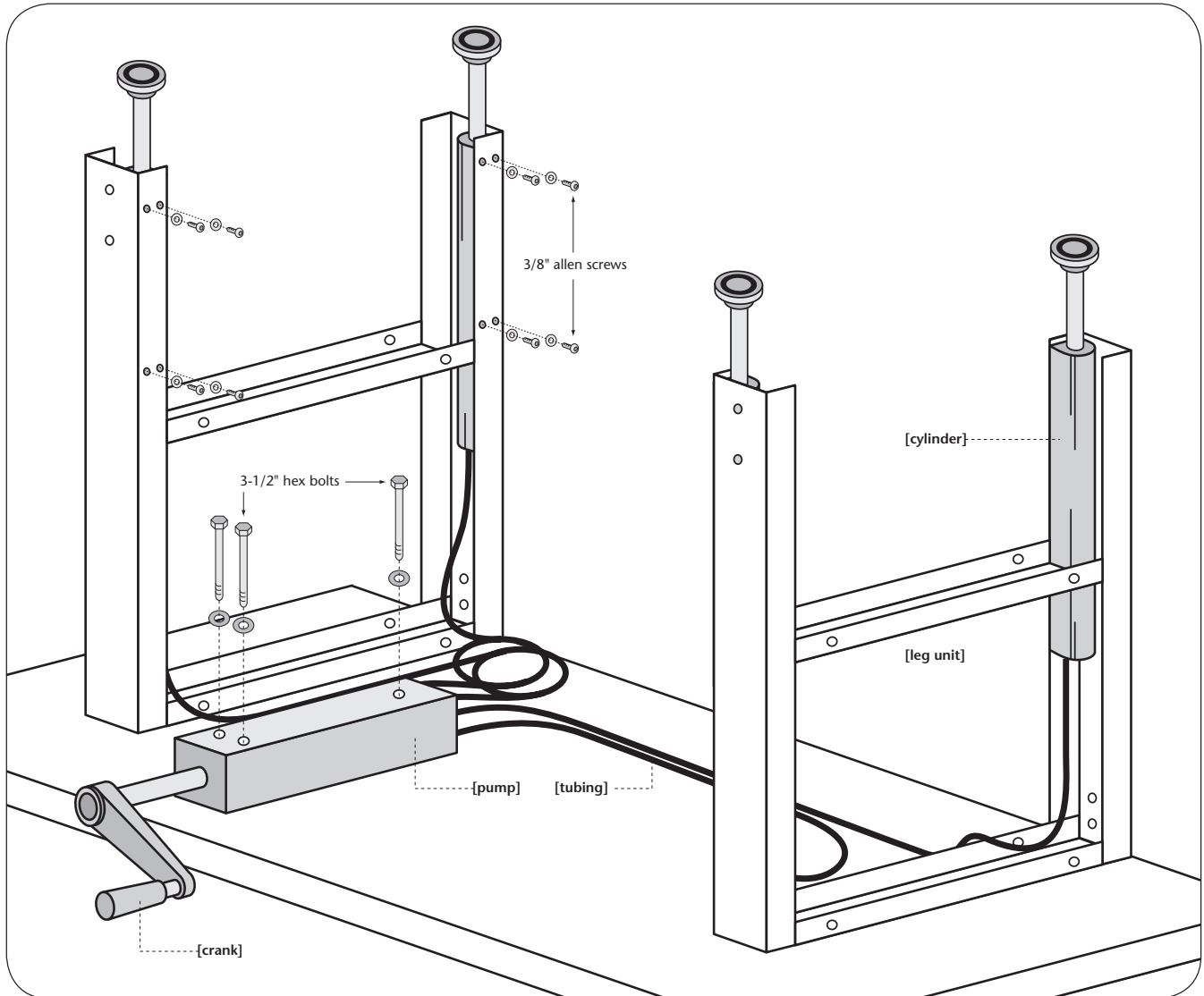

est. 1931

Assembly Instructions

Hydro-lift Bench Assembly



Mounting manual crank Hydro-lift System to bench.

After the bench legs (4 small holes should be facing inward) and all "under-bench" accessories have been installed flip the bench upside down. Begin by laying everything out for placement and making sure all tubes are untangled. Begin by attaching the hydro-lift cylinders to each leg using (4) button head 3/8" allen bolts per cylinder. Once all cylinders are attached, find a good placement for the manual crank pump. This pump features a foldable handle. You want to make sure that the handle can clear the front of the bench top when turned and is set back far enough to conceal the handle when it is folded in. Attach the pump using (3) 3-1/2" hex bolts provided. Finally, fasten the tubing to the top using cable clips. Roll and fasten any excess cable to the top as shown below. Note: To avoid damage to flexible tubing, take special care to route tubing away from sharp edges, moving parts and/or the user. Clips must not grip tubing in any manner and the minimum bend radius for the tubing is 1".