

# OVERHEAD STRUCTURE ASSEMBLY

## MOUNTING ADJUSTABLE SPOOL HOLDER

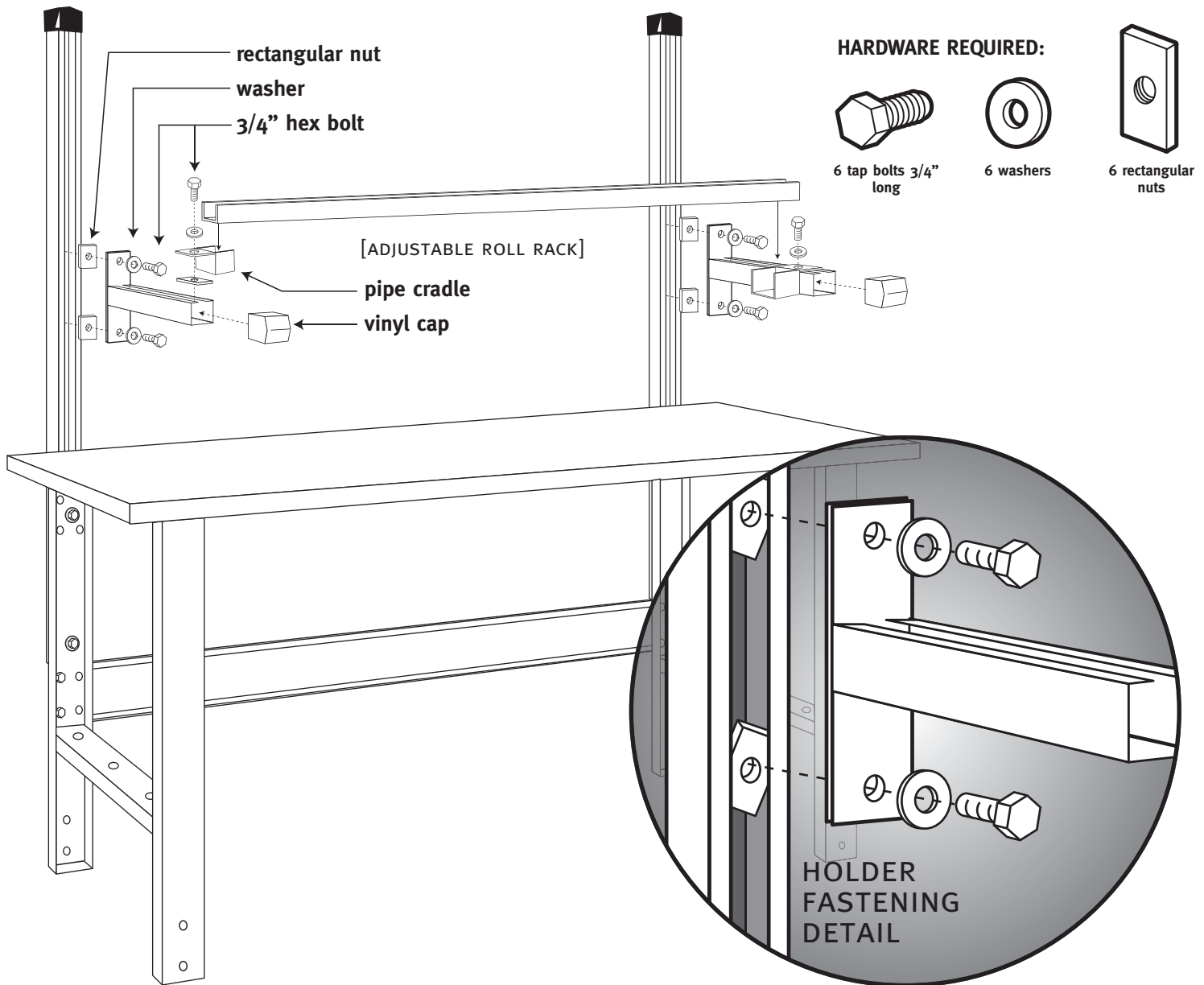

### MOUNTING SPOOL HOLDER TO OVERHEAD STRUCTURE.

Using hardware shown above, mount support arm to upright by loosely threading rectangular nuts onto hex bolt and sliding the support arm into the channel of the upright. Be sure the rectangular nuts inside upright are turned clockwise as far as possible and tighten securely. Using large square nut and adjustment handle, mount pipe cradle to the support arm by loosely attaching all hardware and sliding square nut into opening at end of support arm and tighten. Place black vinyl cap over open end of support arm. By loosening and adjusting hardware, this set-up can be reset at desired location vertically and horizontally. After both sides are adjusted properly and at the same height, insert pipe into both cradles.