

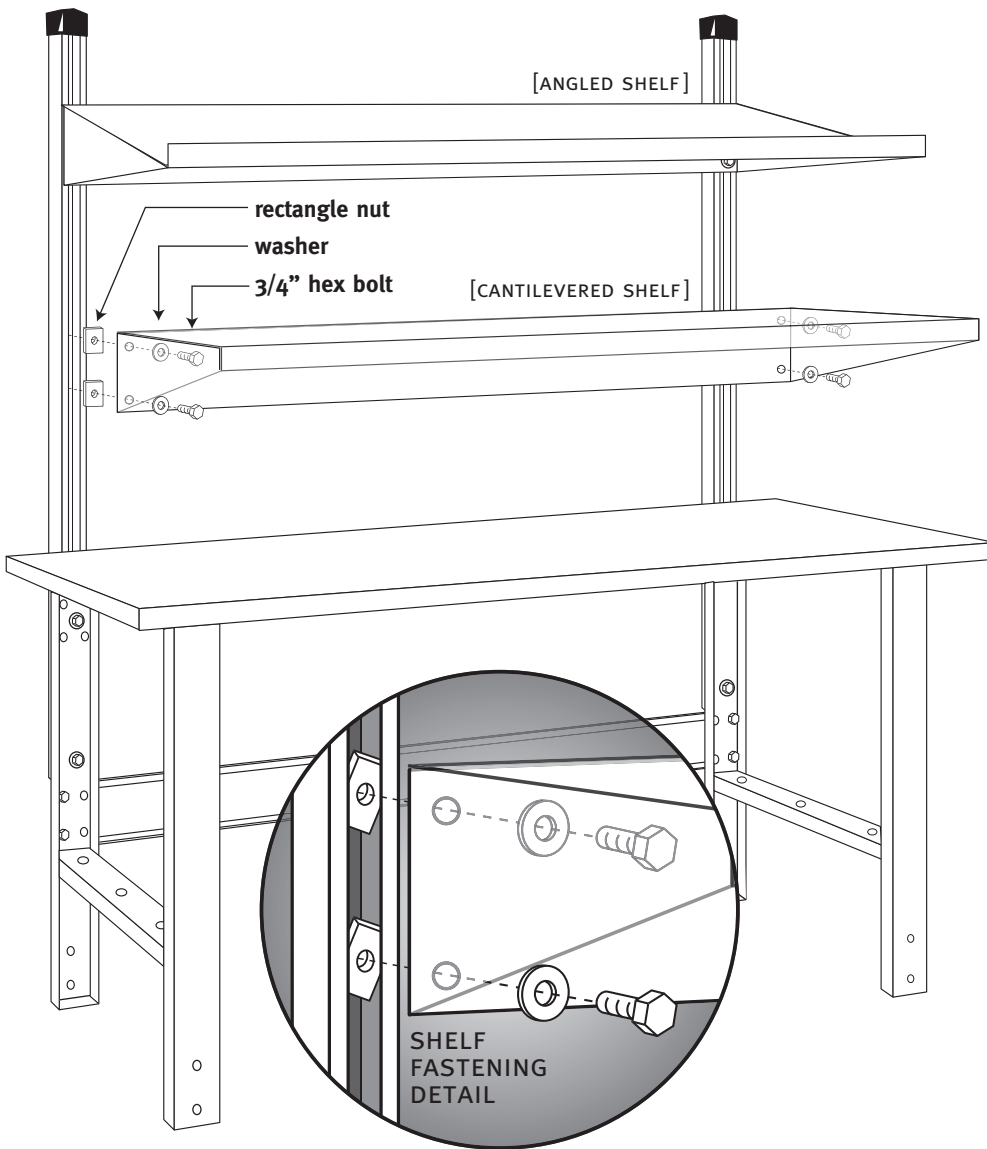

est. 1931

# OVERHEAD STRUCTURE ASSEMBLY

## MOUNTING CANTILEVERED AND ANGLED SHELVES



### HARDWARE REQUIRED:



4 tap bolts 3/4" long



4 washers



4 rectangular nuts

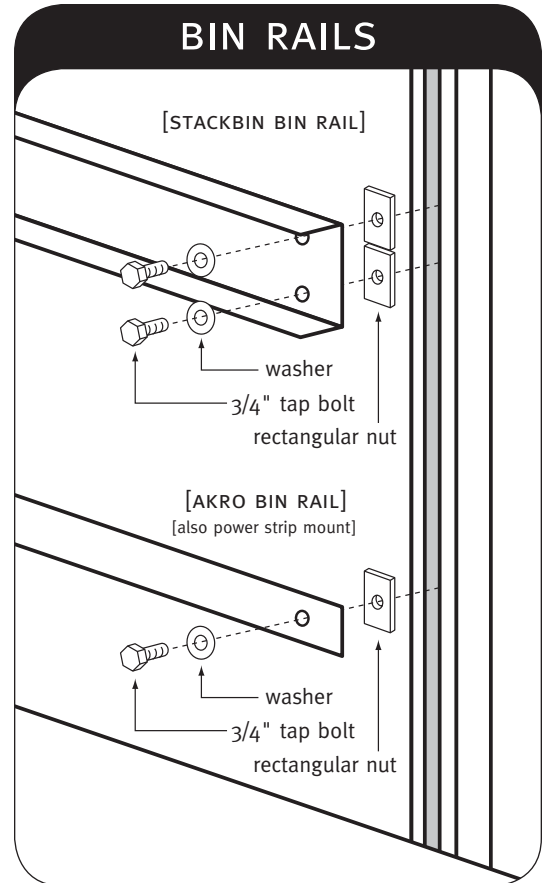

## MOUNTING SHELVES AND BIN RAILS TO OVERHEAD

Please Note: This assembly may require two people. Cantilevered and angled shelves are rated for 75lbs of weight capacity.

Hardware required for Akro bin rails: 2 tap bolts 3/4" long, 2 washers, 2 rectangular nuts. Hardware required for cantilevered shelves or Stackbin bin rails: 4 tap bolts 3/4" long, 4 washers, 4 rectangular nuts.

Insert tap bolts with washers through holes at ends of part to be mounted. Loosely thread rectangular nuts onto tap bolts, stopping with nuts in a vertical position. With one person on each end, tip the tap bolts until nuts slip through slot in overhead upright. Be sure nuts are turned clockwise as far as possible, then tighten tap bolts securely (shown in detail illustration above). This method of installation works for most of Stackbins' Overhead Structure accessories.