

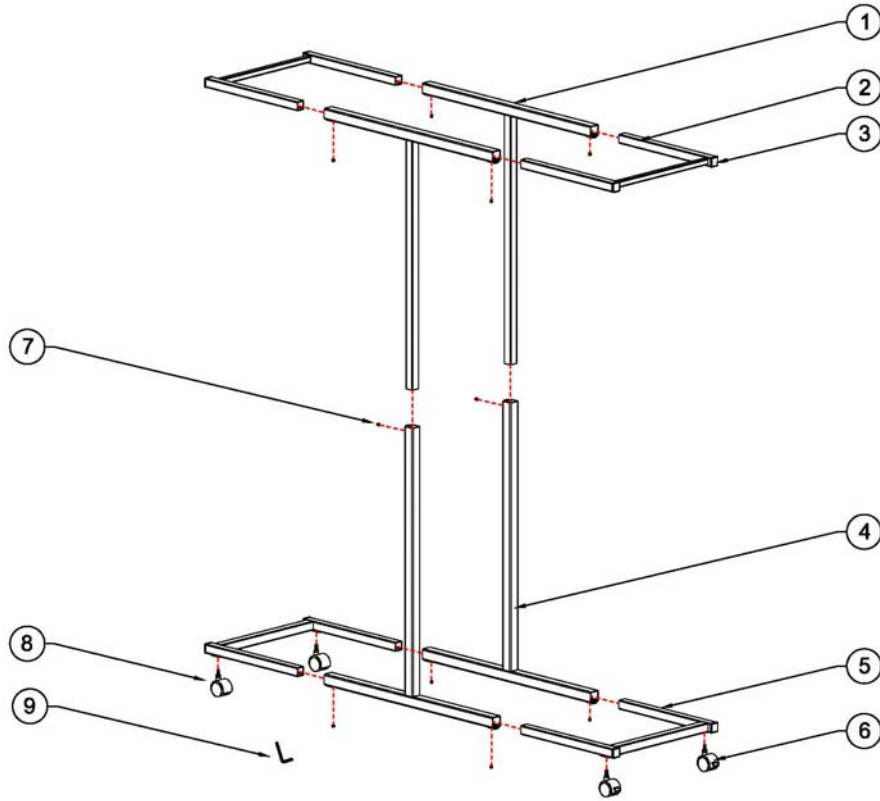









MVPC

Mobile Plan Center Assembly Instructions



PARTS LIST

Part	Description	Qty
1	 Upper tube assembly	2
2	 Upper end tube assembly	2
3	 Tube caps	8
4	 Lower tube assembly	2

Part	Description	Qty
5	 Lower end tube assembly	2
6	 Locking caster	2
7	 M6X8 set screw	10
8	 Non-locking caster	2
9	 Allen key	1

MVPC

Mobile Plan Center Assembly Instructions

- 1) Insert lower end tube assemblies (part 5) with caster weld nuts facing down into lower tube assemblies (part 4). Adjust to size of clamp being used and insert four pcs M6X8 set screw (part 7) into lower tube assembly and tighten with allen key (part 9).

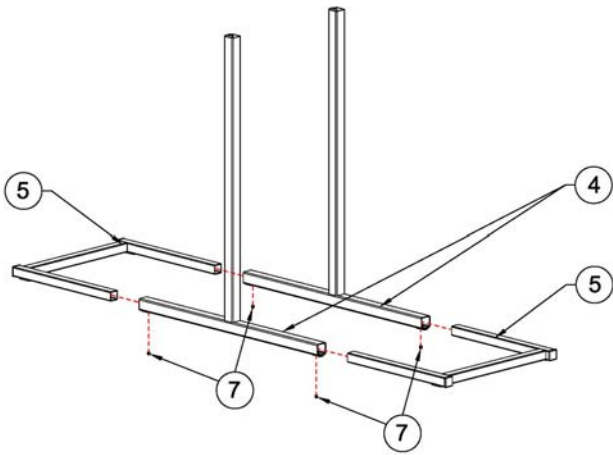

- 2) Screw casters (part 6 and part 8) into lower end tube assembly.

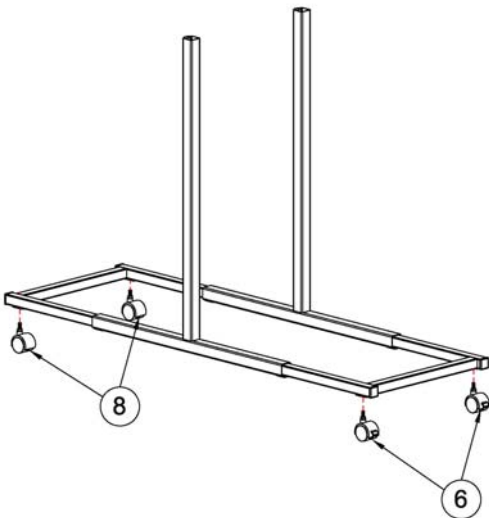

- 3) Insert upper end tube assemblies (part 2) into upper tube assemblies (part 1). Insert four pcs set screws (part 7) into upper tube assembly (part 1). Adjust to size of clamp being used and tighten with allen key.

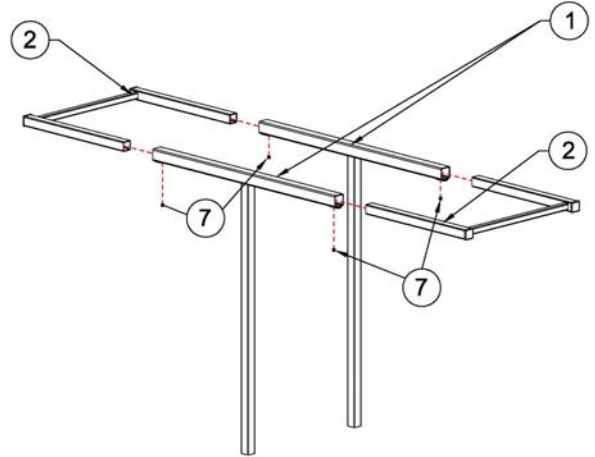

- 4) Slide upper frames into lower frames. Adjust to size of clamp being used and insert two pcs M6X8 set screws into lower tube assembly and tighten with Allen key.(part 9).

