

Story Bookcase
Designed by Afteroom

Customer Service:
1.800.944.2233 inside the U.S.
1.203.614.0600 outside the U.S.

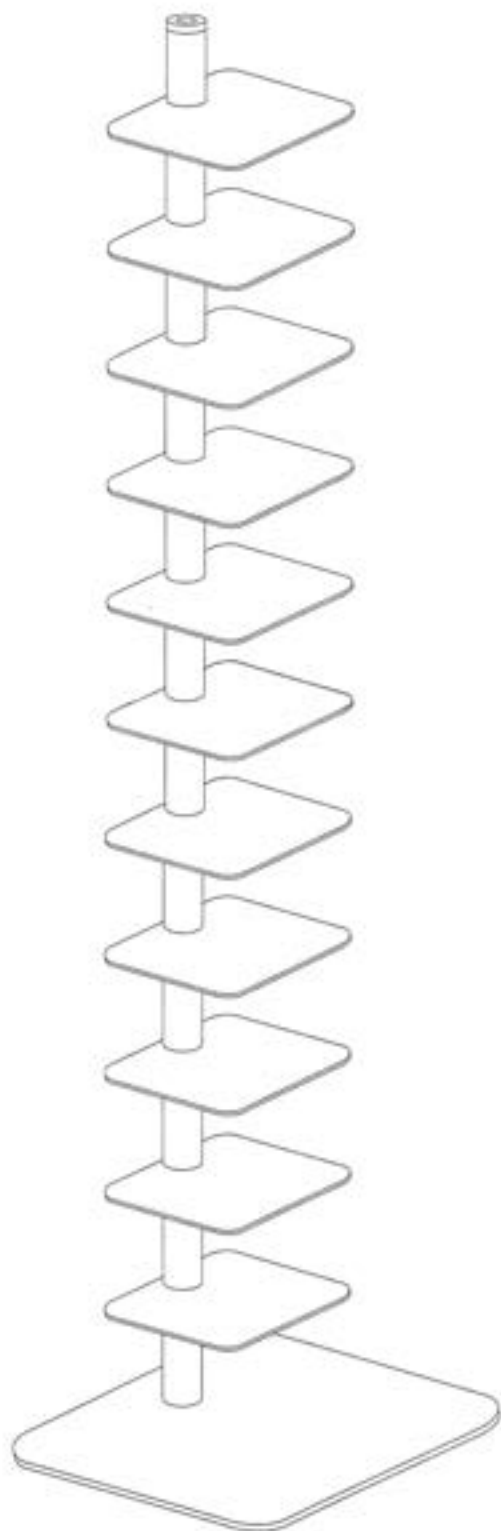

Tall Bookcase

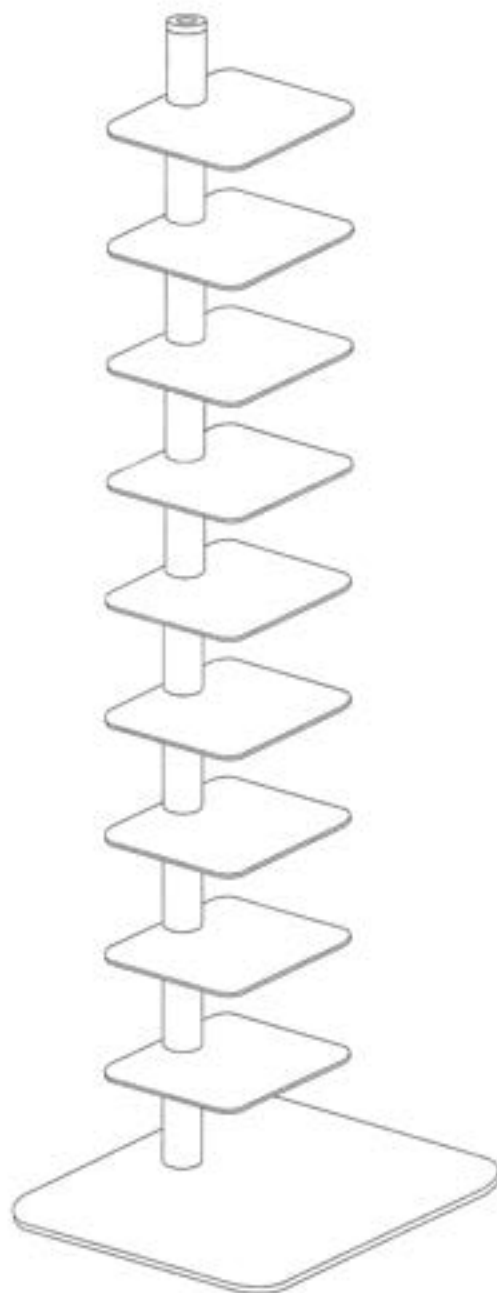

Short Bookcase

Story Bookcase
Designed by Afteroom

Hardware Checklist

Shelf
x 9 or x 11



Inner Tube
x 1

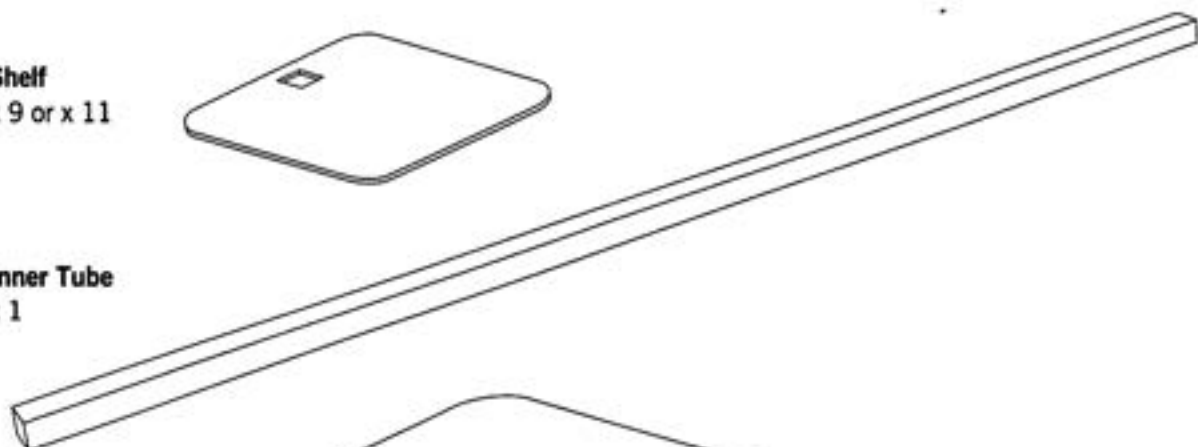

Base
x 1

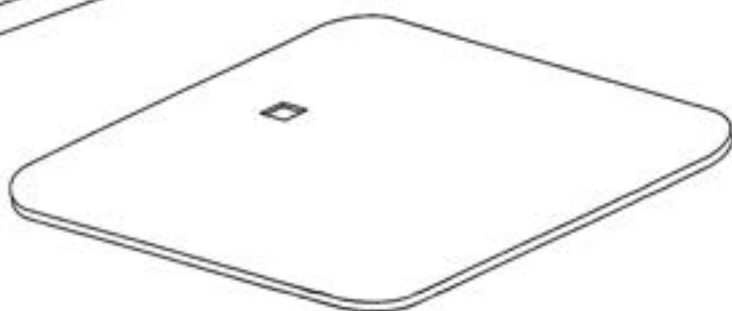

Top sleeve
x 1



Topper
x 1



Sleeve
x 9 or x 11



Cap
x 1



Bolt
x 2



Washer
x 2



Screw
x 2

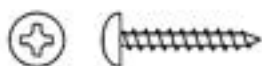

Adjustable safety strap
x 1



Allen wrench
x 1



Self-tapping wall anchor
x 2

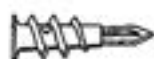

Felt foot pads
x 4

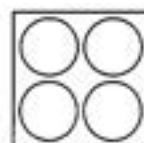

Story Bookcase
Designed by Afteroom

1. Place felt foot pads onto disks on underside of base as shown, then bolt inner tube to base using one bolt.

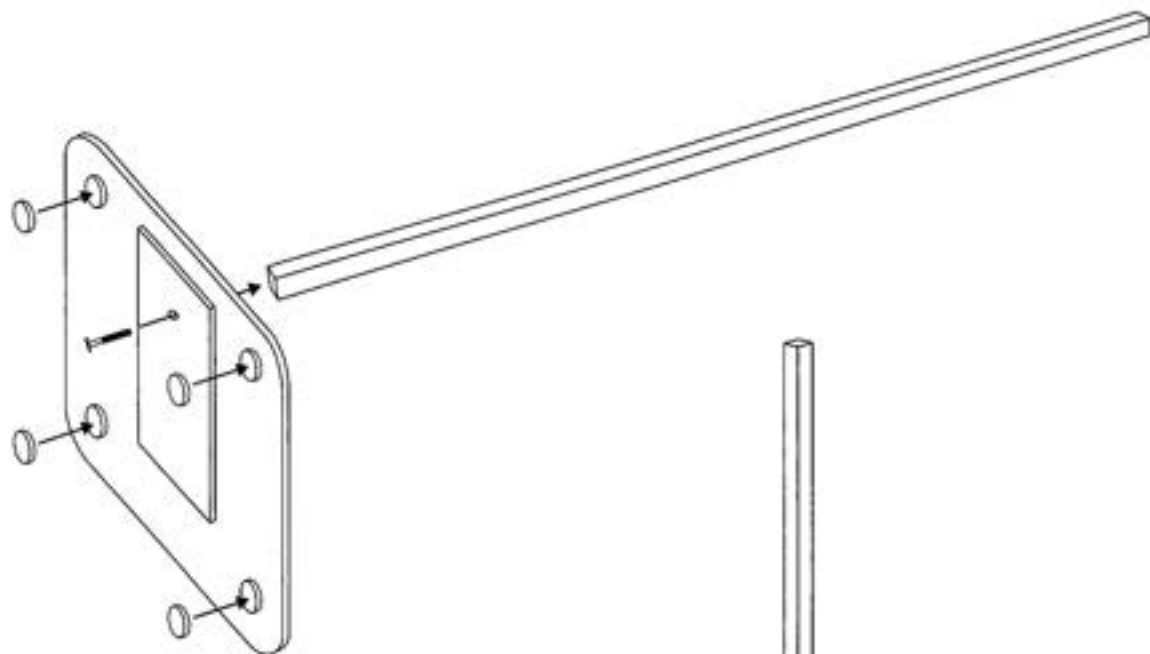

2. Slide one sleeve down inner tube, then one shelf.

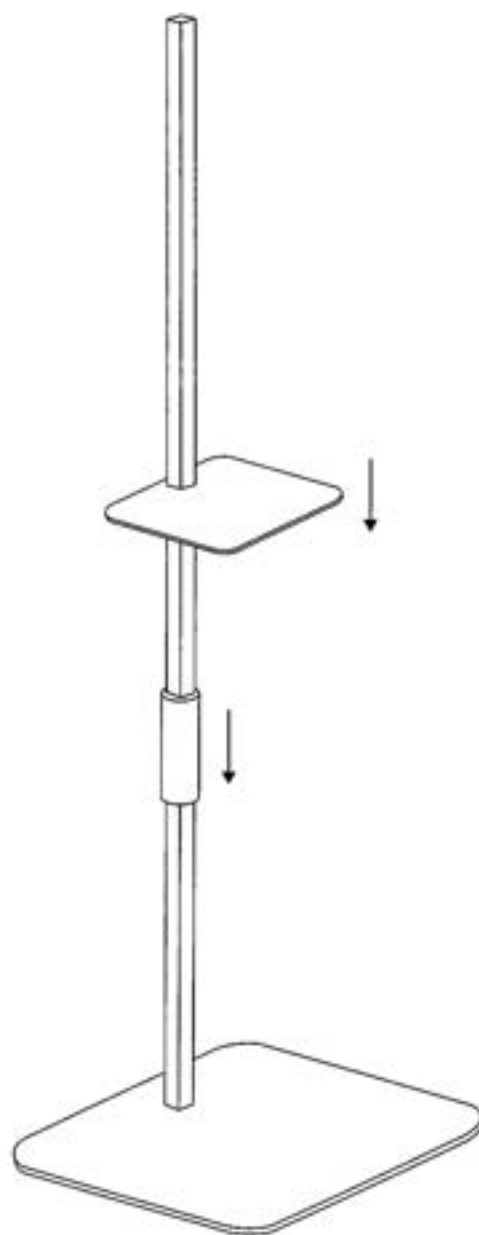

Story Bookcase
Designed by Afteroom

3. Continue to alternate one sleeve, then one shelf until all have been installed.

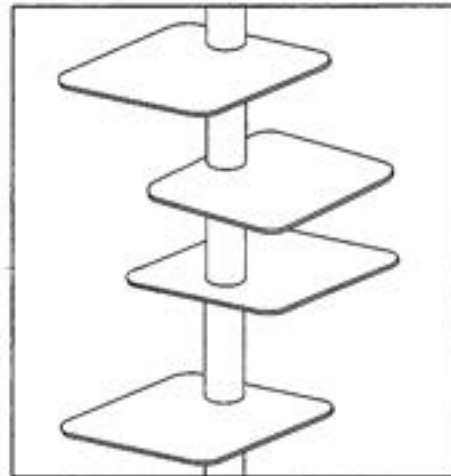
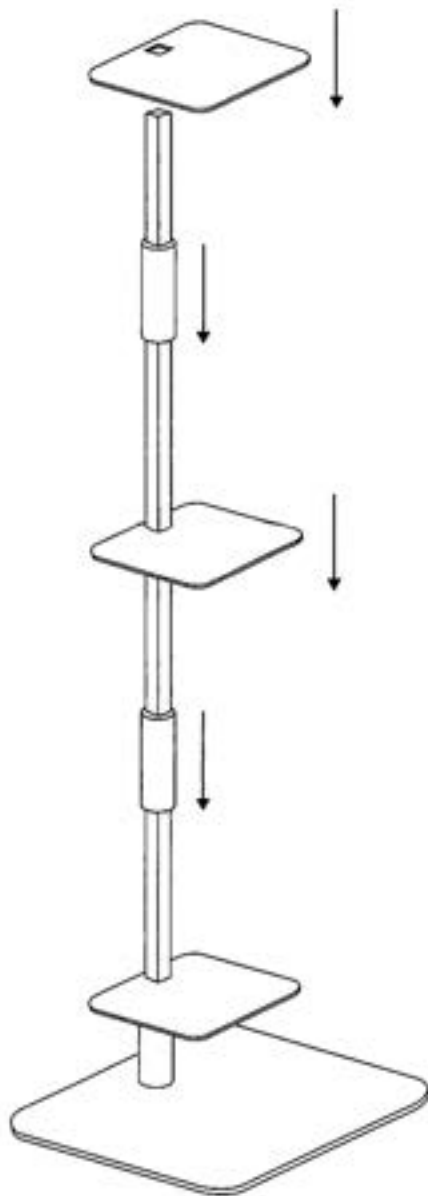

Shelves may be oriented to face left, right, or forward. Do not, however, face them rearward.

Story Bookcase
Designed by Afteroom

4. Finish with top sleeve, cap, one bolt, and topper.

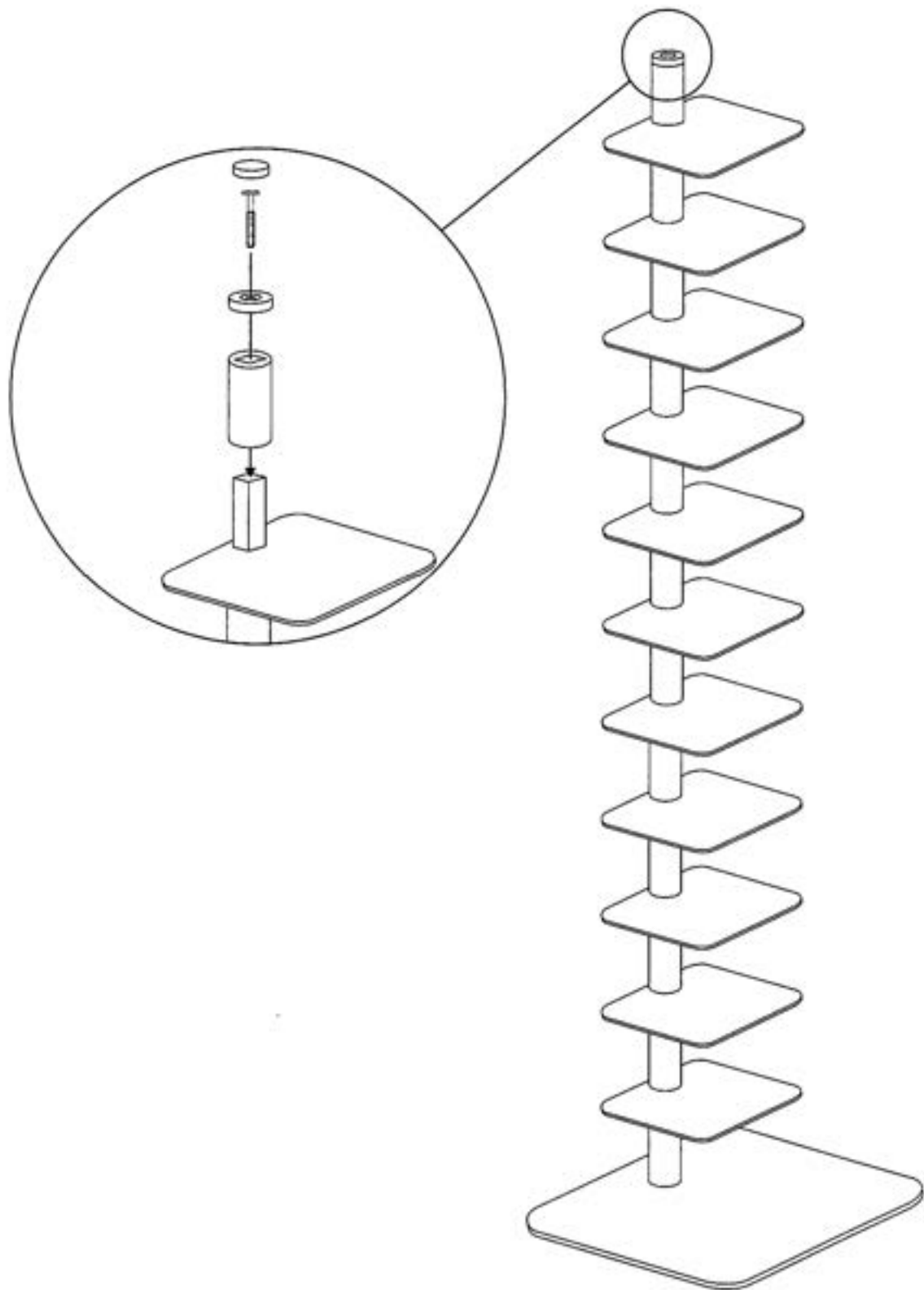

Story Bookcase
Designed by Afteroom

5. Wrap safety strap around post near center of column. Secure to wall using self-tapping wall anchor, washers, and screws, as shown. Please note that provided wall anchors are intended for use on drywall. Be sure to use an anchoring system appropriate for your wall material.

