

Wheel Fanatyk Spoke Cutting & Threading machine (SCT)
mounting template (Letter)
 Scale: 1:1

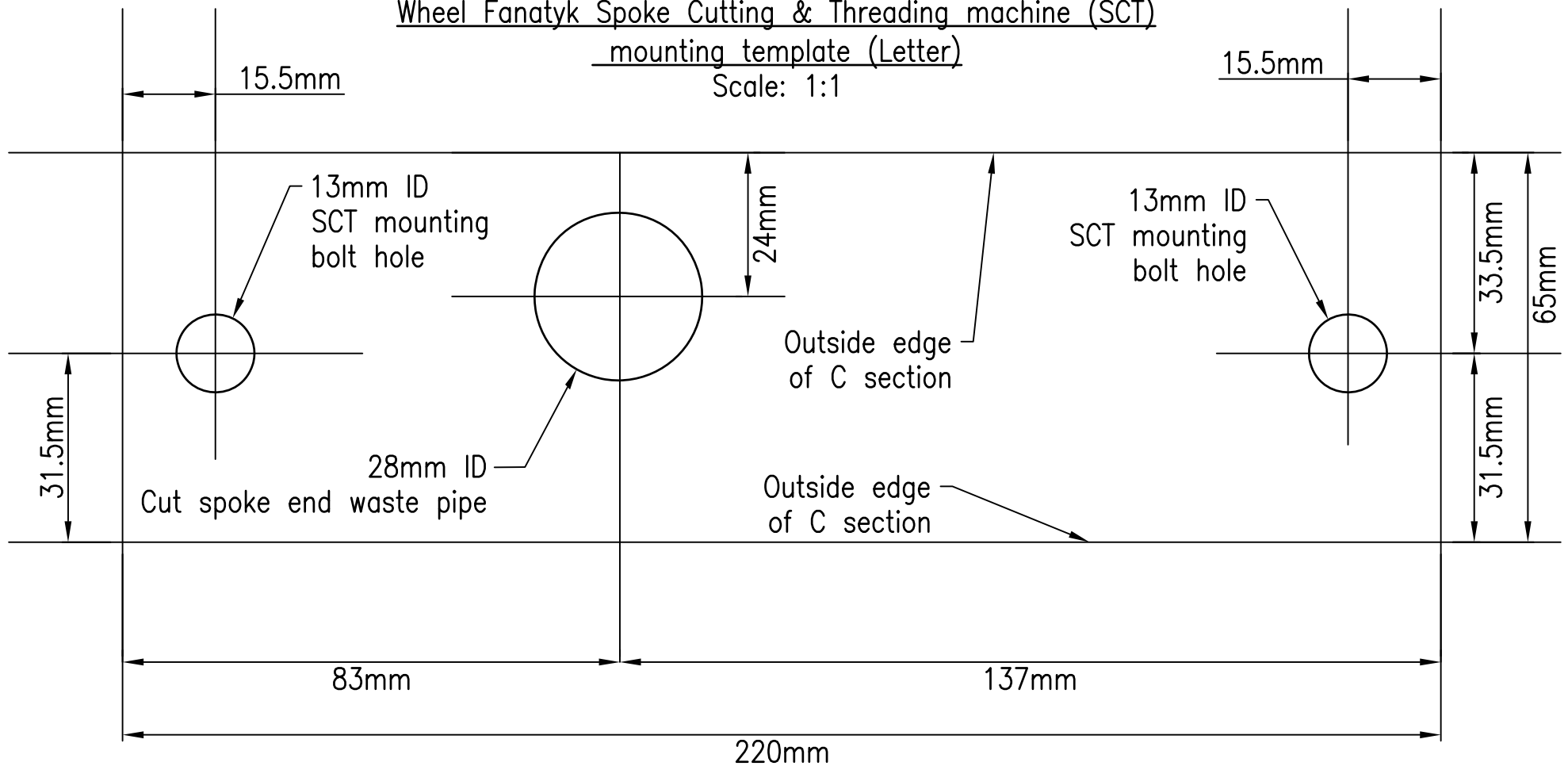

How to use this template

1. Print the template on Letter size paper with no scaling (100%/full size).
2. Check the dimensions of the printed template with a scale/ruler/tape measure to insure that the dimensions shown on the printed template match what you measure. If not, check your printer scale settings to insure that you are not shrinking or enlarging the printout.
3. Carefully align the full size mounting template on the work surface where the SCT machine will be mounted.
4. Drill the mounting holes where indicated on the template. If you've done this correctly, the the SCT machine mounting bolt holes and Spoke end waste tube hole will align with the holes you've just drilled.
5. A tip: place the SCT machine on top of the mounting template to ensure you can see the template mounting holes BEFORE you drill the holes!