



# Engine<sup>V2</sup>

Dual Complex VCO with wave shaping and modulation features



## Build Guide

SMD-PCB V1.1 Jul 2023

Written and illustrated by Ruben Sponar



## Introduction

This Build Guide is written for builders with experience in soldering and assembling PCBs. Due to the complexity of the build, the guide is focused on the steps that require special care or techniques. Therefore, not every component value is described and listed as a single step.

## Tools Required / recommended

Soldering iron (+wire)  
side-cutter  
Digital Multimeter  
snipe nose plier  
flat head screwdriver  
Nut wrench / driver M6, M8, M9  
Helping (third) hand / PCB holder

## BUILD GUIDE

### STEP 1

#### Polystyrene Capacitor

Place the Polystyrene (or other high quality) capacitors.

If it has a polarization, the marking on the capacitor should point towards the white line on the PCB.

A normal ceramic cap will work as well, but since it may affect the stability of the VCO cores, you should use high quality Plastic Film capacitors. Make sure, they are not taller than 10mm.

2	1n Polystyrene	C13,C5
---	----------------	--------

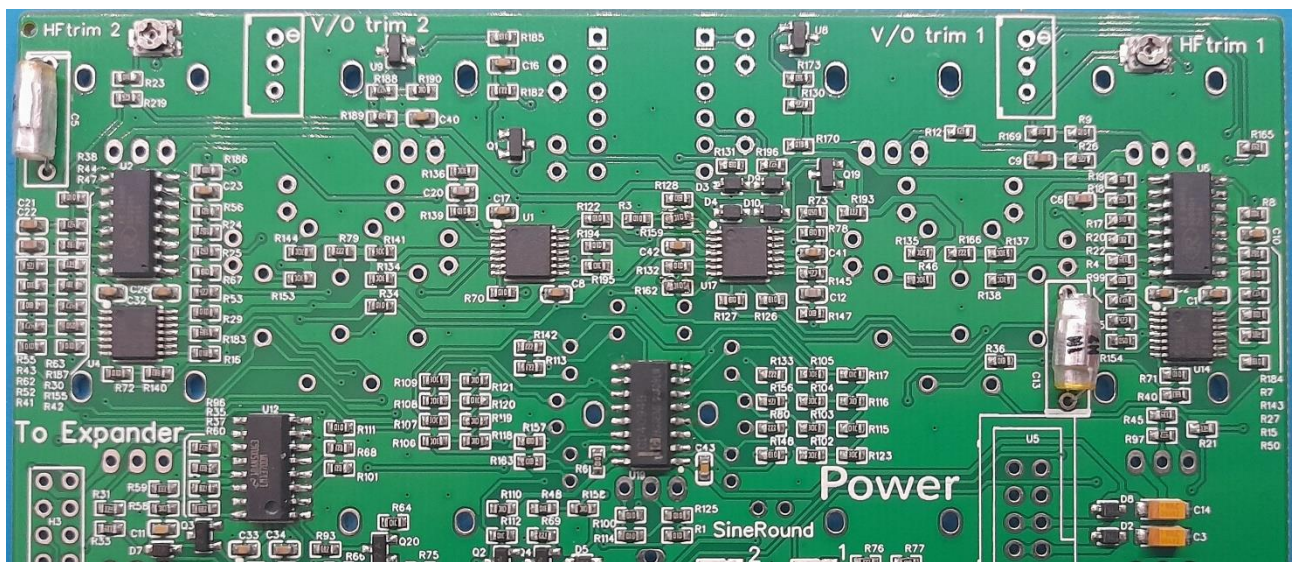

**STEP 2**

Pin headers

Turn around the board and place the Pin Headers for Power and the Expander like shown below. Orientation of the 16 Pin Power Header is very important to be able to insert the power cable the correct way.

Put some tape, to hold them in place while soldering from the other side.

1	Euro rack Power 16 Pin IDC	U5
1	HDR-M-2.54_2x5	H3

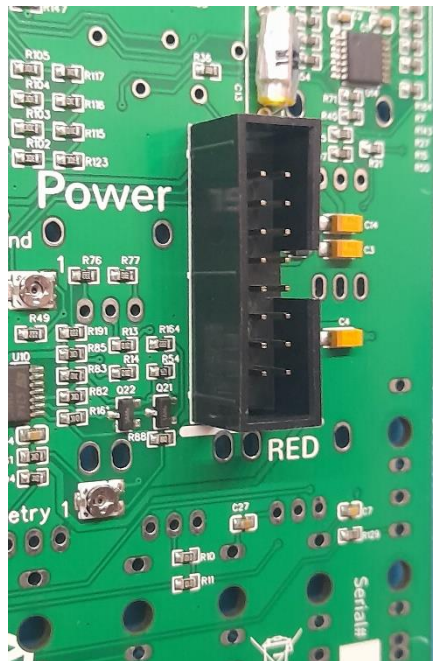
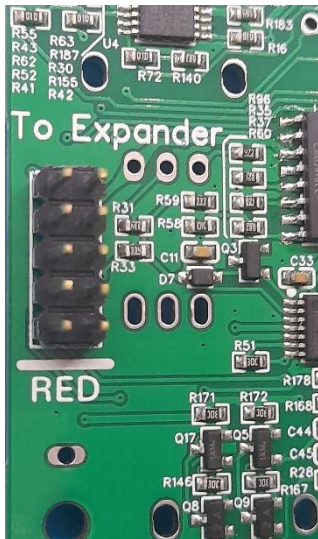

**STEP 3 (Main PCB)**

Trimmers

Place the 2 Trimmers according to the marking on the PCB, like shown in the picture below.

2	V/O trim	TRIM2_10K,TRIM4_10K
---	----------	---------------------

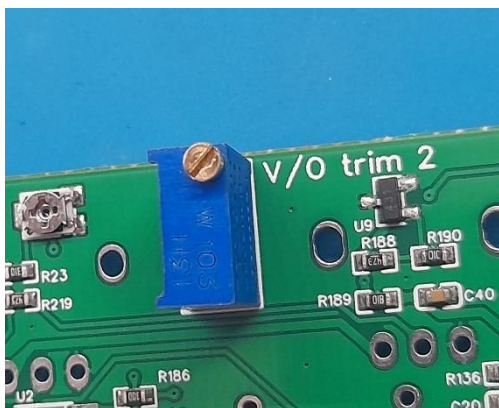

**STEP 4 (Switch PCB)**

Take the small Switch adapter PCB and the 4 position slide switch. Place the switch on the side that says SW3. It is recommended to use a helping hand to secure them together while soldering. When soldered, cut the solder legs flush with the PCB to avoid shorting them later! Then put it aside for later use.

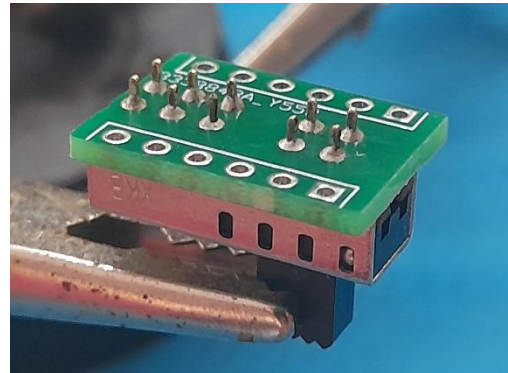
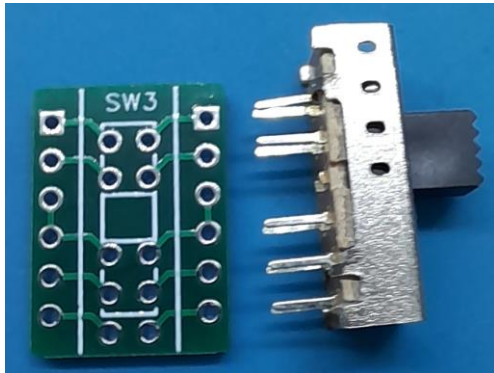
**STEP 5 (Switch PCB)**

Male pin headers

Place the 1x6 Male pin headers on the PCB, with the longer pins facing down. Then fit the Switch with its adapter PCB on top, like shown below. Solder from top (the side of the switch) but wait with soldering the other side. Then take it out and leave it for later.

2	HDR-M-2.54_1x6	J28,J31
---	----------------	---------

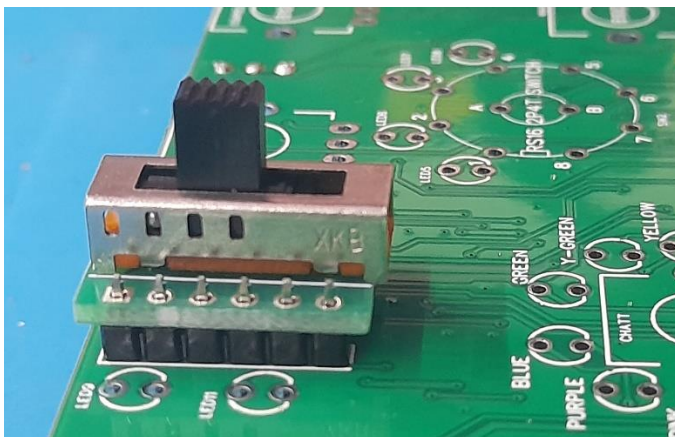

**STEP 6**

LEDs

12	LED-TH-3mm_W	LED1.....LED12
8	LED-TH-3mm_CLR	RED,PINK,PURPLE,BLUE,GREEN,Y-GREEN,YELLOW,ORANGE
20	LED-Spacer 4mm	

First place the LED spacers on the white LEDs like this

Then insert all white LEDs on their spots around the switches. For the LEDs, orientation is important! The longer leg goes in the upper hole, while the flat side of the LED points down.

Only solder 1 leg of each LED! Then check all LEDs, they should stand vertically to the PCB. Adjust if necessary.

Then solder the remaining pins.

For the colored LEDs it is recommended to put the spacer and place the LEDs individually to not swap colors.



This is the PCB with all LEDs in place.

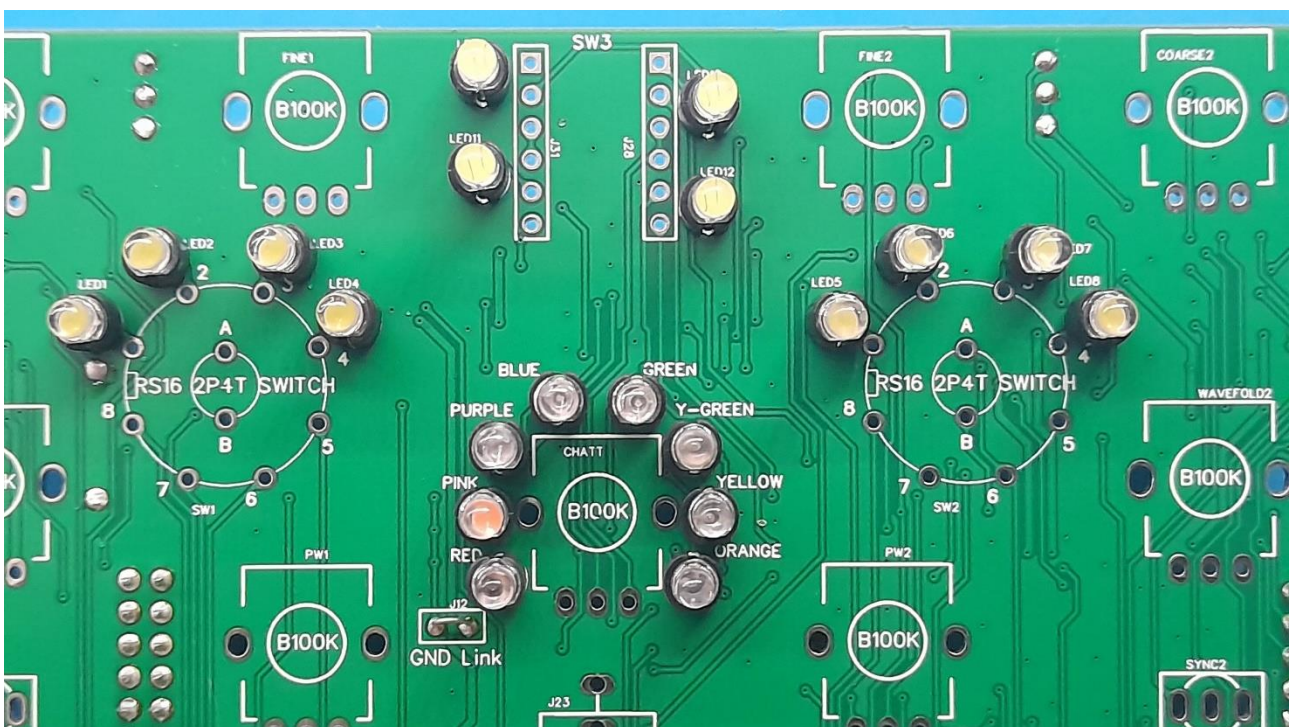

**STEP 7**  
Controls

Now take the Potentiometers, jacks and switches and put them in place as marked on the PCB but don't solder yet!

Before placing the rotary switches, cut the anti-rotation pin like shown below.

The solder pins may be bent a bit due to transportation. Make sure they stand off straight when placing on the PCB.

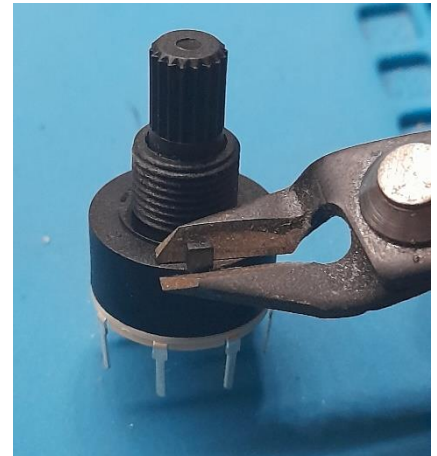

The Toggle switch for Sync2 on the right is On-Off-On (with a middle position)

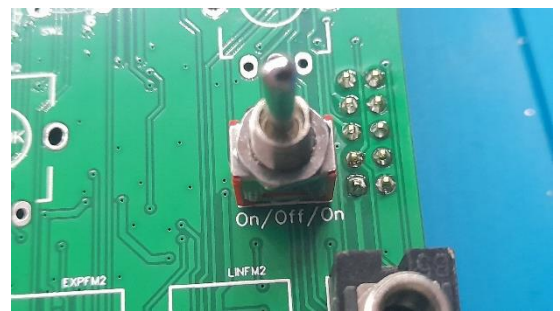

Below you can see the placement for the Controls.

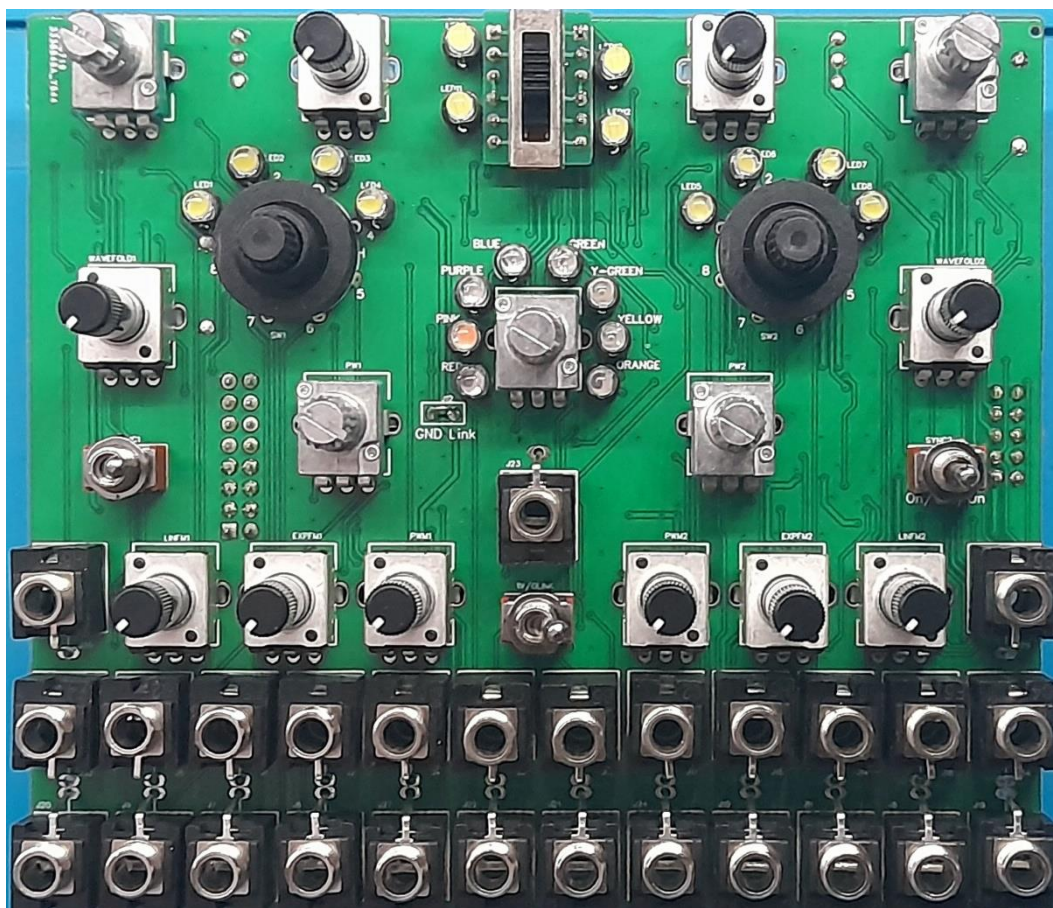

**STEP 8**

## Front Panel

When everything is in place, take the front panel and put it on top, so all controls go into each corresponding hole of the panel. Since it is over 40 parts that need to fit, "wiggle" the front panel into place and make sure everything fits well.

Fit all washers and nuts to the Potentiometers, Jacks and Rotary switches. Be careful when turning the module around, so that the components stay in place.

Then solder everything.





**STEP 9**

## Knobs

Place the knobs on the Potentiometers. For best results, turn all Potentiometers counter-clockwise and push on the knobs, so the marking points towards the left end of the surrounding circle.

**STEP 18**

## final check

Check your soldering. If you see shorts or bad solder joints, fix it up. Then check the power pins for shorts with your multimeter.

If everything looks fine, you can proceed with calibration.

## Step 19 - Calibration

Before your module is finished, you need to calibrate the trimmers on the back.

To do so, plug in the 16pin Eurorack Power cable correctly to your Bus board and the Module while your rack is powered OFF! Make sure orientation is correct. (Red stripe to the -12V side). Then turn on your case.

### Sine wave calibration

Plug the sine wave output of VCO 1 to an oscilloscope.

There is two little single turn trimmers for each VCO. First adjust the "Sine Symmetry1" so the wave looks the same on top and bottom ends, and swing around 0V. It may show values between -4,5V to +4,5V and -5,5V to +5,5V.

Then adjust "Sine Round1", so the curve shows nice, rounded sine shapes.

You can also check with a frequency spectrum analyzer (most plugin EQs have one) and adjust to keep the overtones as low as possible.

Then repeat for VCO 2.

### 1 V/octave tuning

To adjust the V/oct, plug a Keyboard/Sequencer or MIDI-interface, that produces 1V/oct signals to the 1V/O input of VCO1. Play the lowest C and tune VCO1 to play a C. Then press the C1 on your keyboard (one octave higher) and adjust the trimmer (without detuning on the Front) so the tuning is exactly note C, one octave higher. Repeat those steps until the VCO always plays a C when you play a C on the keyboard, and up to 10 octaves higher.

Repeat everything for VCO2.

If you prefer, you can also let a sequencer play through 4 octaves in 4 steps (C1, C2, C3, C4) and turn the trimmer, until the tuner always shows the same note in different octaves.

If you don't have a tuning device, but a frequency counter (on the oscilloscope), you can replace the notes with Hz. Tune down to exactly 100hz, the next octave should always double the frequency to 200hz, then 400hz, 800hz, 1600hz and so on.

The HF trim might need to be adjusted. If, by playing in higher frequencies (higher octaves) the V/O tracking is not exact, turn up or down the trimmer, until the high octaves are also stable in pitch.

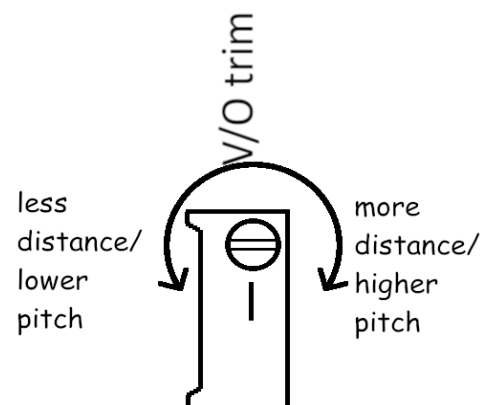

Congratulations, you can now install the module in your rack and have fun patching!

Please understand that we can't guarantee for your DIY module to work. Nevertheless, we will do our best to guide you through the build or to solve problems when needed.

In case there should be parts missing in your Full DIY kits, contact us to ask for replacement /

If you have trouble with your build, you can contact us at:

[cubusynth@gmail.com](mailto:cubusynth@gmail.com)

(or the websites contact form)

To be able to identify mistakes in your build, please include quality pictures of your soldered PCBs, front and back side.

<https://cubusynth.com/>

[https://www.instagram.com/cubusynth\\_modular/](https://www.instagram.com/cubusynth_modular/)

<https://www.facebook.com/cubusynth>

<https://www.etsy.com/shop/CubuSynth>

<https://www.youtube.com/@cubusynth>