

CubuSynth

# Dual CS-20 VCF

**Dual / Stereo Multimode VCF with Self-oscillating Resonance and intuitive Routing and CV modulation Matrix**

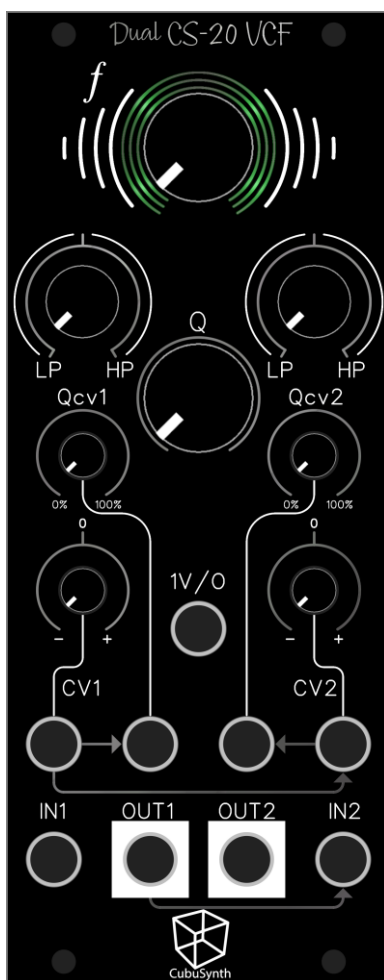

**Manual**

March 2022

## Contents

1. Introduction .....	Page 2
2. Specifications .....	Page 2
3. Key features .....	Page 2
4. Installing the Module .....	Page 3
5. Main Controls .....	Page 4
6. Individual Filter Cores .....	Page 4
7. Modulation Matrix .....	Page 5
8. Cross Modulation .....	Page 5
9. Internal Routing Map .....	Page 6
10. Calibration .....	Page 7

### Limited Warranty:

CubuSynth guarantees this product to be without defects in materials and workmanship for a period of one year from the date of purchase (proof of purchase/invoice needed).

Malfunctions due to improper supply voltages, incorrect or reversed Eurorack power cable connection, misuse of the product, removal of knobs, changing faceplates, or other causes determined by CubuSynth are the user's responsibility and are not covered by this warranty.

During the warranty period, all defective products will be repaired or replaced in the CubuSynth workshop, with the customer paying the shipping costs to us.

CubuSynth takes no responsibility for any damage to persons or equipment caused by the operation of this product.

Please contact [cubusynth@gmail.com](mailto:cubusynth@gmail.com) with any questions, authorization for return to manufacturer or any needs and comments.

## 1. Introduction

The CubuSynth Dual CS-20 VCF is a dual / stereo multimode VCF / Phaser / VCO, inspired by the legendary Korg MS-20, with CV control over frequency and resonance. The resonance can self-oscillate and features a 1V/Oct input, stable over at least 2~3 octaves.

Each of the two filter cores has 2 stages of Low Pass and High Pass filtering, which can be blended together.

The Frequency CV can be “attenuverted” (with inverting attenuator on CV input). The resonance CV comes with an attenuator.

## 2. Specifications

- Size: 10HP / 50mm
- Depth: DIY version: 36 mm (measured from the front panel)  
Built version: 24 mm (measured from the front panel)
- Current Draw:
  - +12V: +19mA
  - 12V: -19mA

## 3. Key features

- 2 individual Filter cores with common Frequency and Resonance controls
- CV control over Frequency and Resonance for each Filter core
- self-oscillating Resonance with LED feedback circuit (visible on the Front)
- 1 V/oct input, tracking over 2~3 octaves
- Blend between LP / HP Filter modes
- Ability to use as 2 pole (12db) stereo HP/LP Filter, 4 pole (24db) mono LP/HP or a Band Pass (12db) Filter.
- Cross FM Modulation possible

## 4. Installing the Module

- Make sure you have 10 hp (50mm) space in your Rack.
- Turn off the Power from your system and unplug Mains Power connection.
- Connect the Eurorack Power Cable into your Bus-Board via 16-pin connector (Correct Orientation!) and via 10-pin connector to the module.

Attention! Make sure the Power is connected the correct way.

You might risk damaging one or more modules in your Rack by reversed Power connectors.

- When Power is connected, you can Place the Module in your case and fix it with 4 screws to the Rails.

Reconnect the Power to your Case and Power on your System.

When Powering on the module for the first time, set the Resonance knob (Q) to 100% / Fully clockwise. If the LEDs behind the Frequency knob do not light up, Power off your system immediately and [contact us](#) for solutions.

(For DIY builds, refer to the build guide and try to find soldering mistakes in your module)

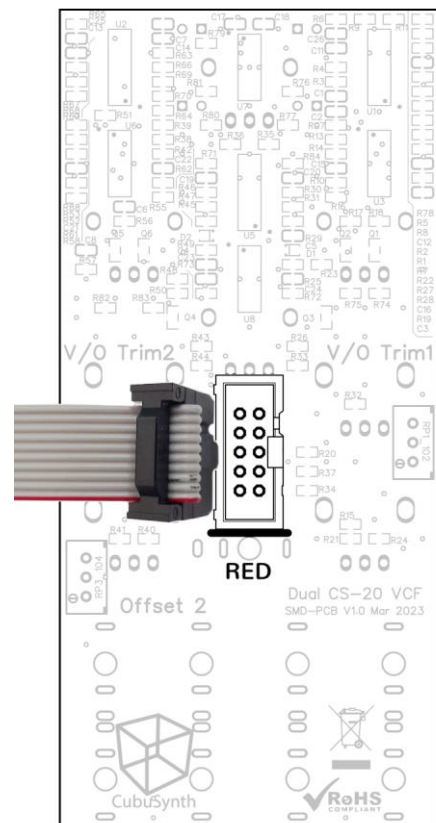

## 5. Main Controls

The three Main controls affect both Filter cores equally. These are the Main Frequency knob, the resonance knob and the 1 V/ octave input.

When the Resonance knob (Q) is set above middle position it will start to self-oscillate. This will be visualized by a green light around the frequency knob.

For Self-Oscillating mode, set the Resonance to 100% for best 1V /octave tracking accuracy.

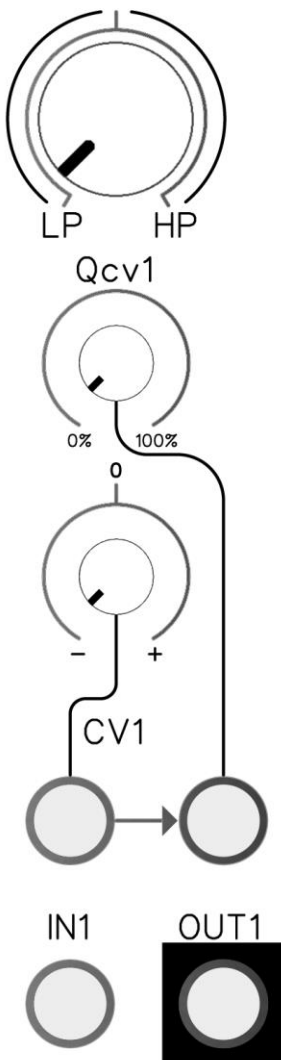
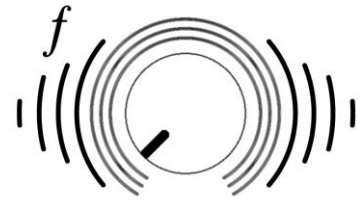

## 6. Individual Filter cores

Each of the two filter cores consists of a two pole (12db) Filter with a “LP/HP Blend” knob, which lets you choose the Filter-Mode from Low-Pass over some kind of Notch/Phaser to High-Pass.

The Qcv attenuator controls the amount of the incoming CV signal for Resonance. This CV input is normalled from the frequency CV input. The normalization is visible by the silver arrows on the front panel.

The frequency CV input features an attenuverter, which lets you scale the incoming signal normally or inverted, with “off state” in middle position.

## 7. Modulation Matrix

The CV inputs are normalled in a way, that you can modulate frequency and resonance of both filter cores with only one CV signal. The normalization path is visible by the silver arrows on the front panel. (here in green)

Plugging a cable into a socket that has an arrow pointed to, will disconnect the normalled signal path.

This means, you can modulate frequency and resonance on the left filter with one signal and on the right filter with another one. Or use 4 completely different CV modulations.

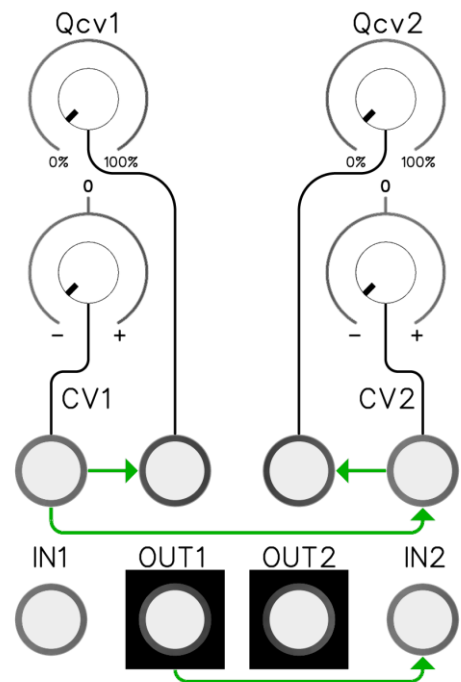

## 8. Cross modulation

While the resonance is in self-oscillation, you can use the output of one Filter, to modulate the other one (and/or itself).

This will result in very unexpected (especially for a filter), glitchy FM sounds.

To not have the Output from OUT1 normalled to the IN2, you will need to plug a cable or Jack connector into IN2.

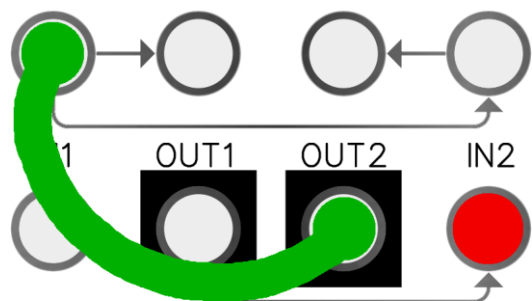

### 9. Internal Routing Map

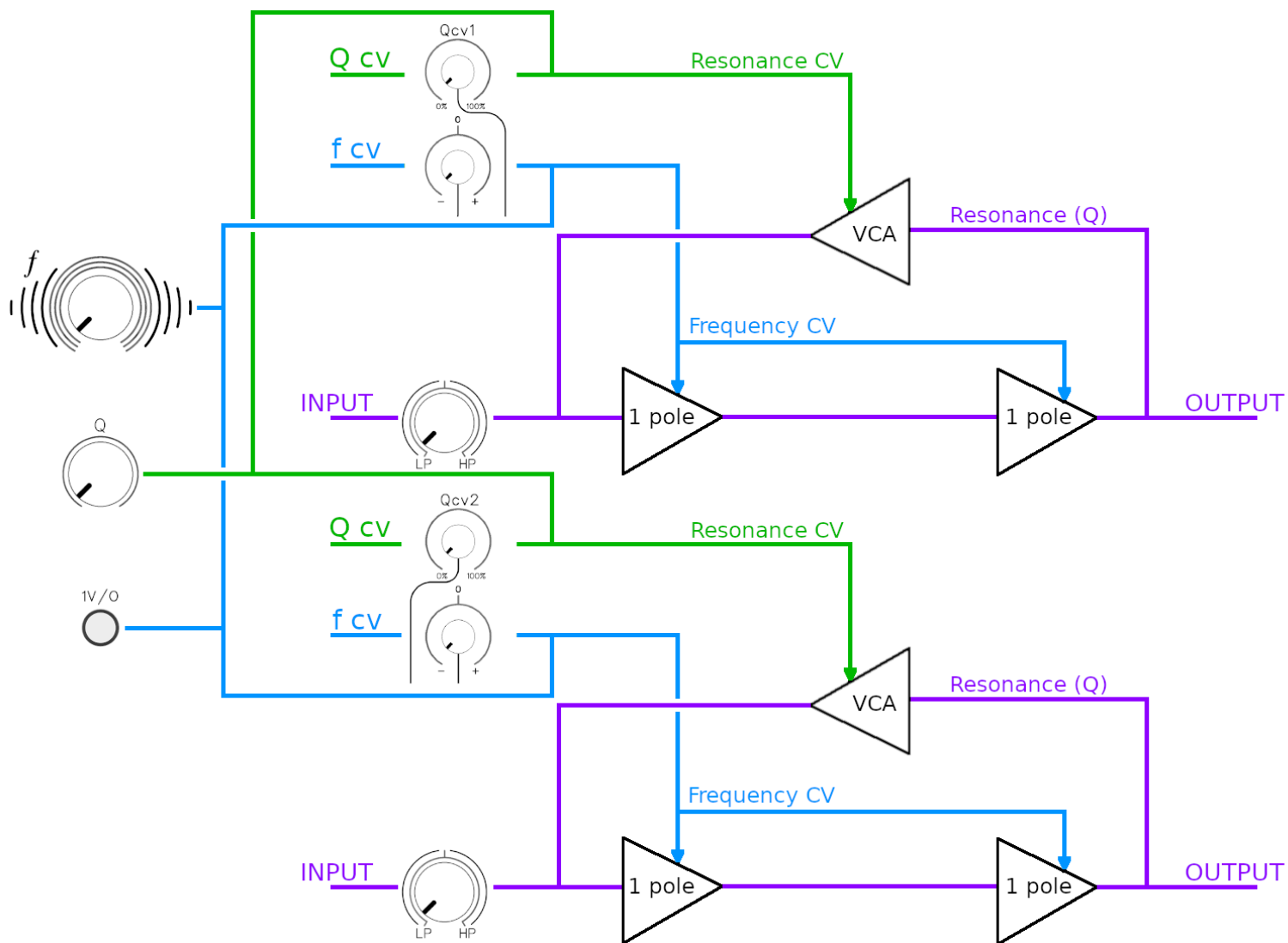

## 10. Calibration

The Calibration process contains the two trimmers for the 1V/octave scaling and an Offset for the second Filters frequency to have them both on the same resonant frequency.

V/O Trim1:

1. Turn the Resonance (Q) knob all the way clockwise (100%) and both filter modes to LP (counterclockwise / 0%)
2. Plug the Output (OUT1) from the Module to an Oscilloscope or musical Tuner
3. Turn the Frequency down to 220hz (or a musical note of your choice)
4. Apply 1V to the 1V/O input (one octave on a keyboard)
5. Trim the V/O Trim1 on the Back of the module until the frequency doubles (440hz/ One octave above initial note)
6. Repeat steps 3-5 until the frequencies match -

V/O Trim2:

7. Plug a cable or a Jack connector to IN2 (to break connection from OUT1)
8. Repeat steps 2-6 for the Output “OUT2” and V/O Trim2

Offset 2:

9. Plug a cable or a Jack connector to IN2 (to break connection from OUT1)
10. Connect both Outputs to a mixer and mix them with same levels
11. Turn the Trimmer “Offset 2” until the frequencies of both outputs match.

Now turn the Frequency knob and assure that the frequency of both outputs stays the same over the audible range.

If not, you will notice some “swinging” or phasing between them. Go back to adjust the V/O Trimmers until they match.

This concludes the Trimming process and you can enjoy your module in perfect state.

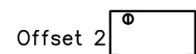
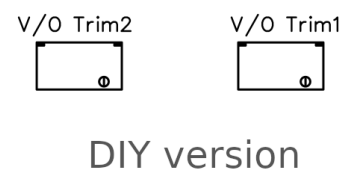



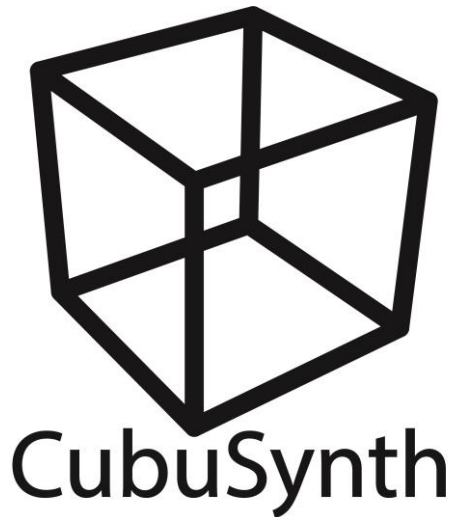

# Dual CS-20 VCF

March 2023

Written and illustrated by Ruben Sponar

The CubuSynth Dual CS-20 VCF was designed by Ruben Sponar, from first prototype in December 2021 to the finished module in March 2023.

A few honorable mentions:

The main Filter circuit is based around the Korg MS-20 Filter.

Blending between LP/HP was inspired by the Kassutronics KS-20.

The VCA for the Resonance feedback path, was originally designed by Tom Wiltshire (electric druid).