

# Redline

PERFORMANCE

## PERFORMANCE PARTS CATALOGUE 2010-2011

*Take it to the red*



**Manufacturer for Racers**

*Build your dream*



**Bolt-on Performance Products**

*Living Life in the Red*



**Manufacturing Performance Since 1958**

- High Performance Filters • Chrome Dress up • Manifolds • Race Gauges • Carby Adaptors •

[www.redlineauto.com.au](http://www.redlineauto.com.au)

## terms of sale

### Products

A large number of products are designed and developed in Australia and manufactured in USA, Australia and Taiwan.

Beware - some products contained in this catalogue are covered by registered design. Copying of these products infringe design registration.

### Limited warranty and liability

The goods sold hereunder are warranted to be free at time of shipment of defects in material and workmanship subject to the following provisions. Every claim on account of defective goods, short count or any other cause shall be deemed waived by the purchaser, unless made in writing within seven (7) days from the receipt of the goods to which such a claim relates. Goods claimed to be defective may be returned to the seller after inspection by the seller and upon receipt of written instruction from the seller. Goods so returned and found to have been defective at the time of shipment will be replaced or repaired by the seller without charge, but the seller shall not be liable for any loss of business, consequential damages or any other expense, loss or damage incurred by purchaser or any other entity, whether directly or indirectly arising out of the goods sold hereunder. Seller's liability hereunder is expressly limited to the replacement or repair of defective goods returned to it in the manner provided above.

The foregoing warranty shall be in lieu of and excludes all other warranties, express or implied, which are hereby expressly disclaimed.

Above warranty only applies to goods, not freight (see Freight Terms).

### Change in prices

All prices are subject to change without notice. Advance notice of price changes will be given whenever possible. There is no obligation to comply with suggested list prices or pre-discounted prices.

### Accounts

- (1) The discounted price shown on invoices is only valid if the invoice is paid within our 30-day trading terms otherwise goods will be re-invoiced at pre-discounted price plus GST.
- (2) All prices listed are based on a strictly nett 30 day trading account.
- (3) All accounts which exceed 60 days are subject to 1.5% per month service charge until paid.
- (4) All costs incurred including all legal costs, service charges or any other expenses entailed in recovering the debt will be added to the outstanding amount.
- (5) If the invoice is marked with a settlement discount if paid within a set time, then your invoice can be adjusted if paid in this time. Please write invoice number you are paying on the back of your cheque.
- (6) No discount allowed on invoices of face value under \$25.00.

### Credit returns

- (1) Goods returned must be in resaleable condition and freight paid by purchaser.
- (2) Invoice number, date of purchase quoted and reason for return.
- (3) Credits must not be deducted from your account until the official credit note is issued.
- (4) All goods returned will be subjected to a 20% restocking charge with the exception of faulty goods. It takes time to parcel up, invoice, then despatch goods, so make sure you order the correct item or take a deposit from your customer.
- (5) All sales are final and goods will not be accepted for return after 30 days.
- (6) Invoices marked not returnable for credit will not be accepted for return under any circumstances.

### Warning

Certain state laws and regulations make the fitting of some motor accessories and performance equipment illegal on certain model cars, other than those used for racing or off-road purposes.

It is your responsibility to ensure that goods you are purchasing or selling can be legally fitted to the intended vehicle.

### Freight

Customers, we do not pay freight and insurance charges as these costs are not included in the sale price of the goods. Freight of all goods are at the purchaser's risk. Sydney customers, we will despatch your goods where possible by the cheapest delivery service and add the cost to your invoice. All goods become customer responsibility on removal or despatch from our premises. Hardiman Auto Supplies will not insure goods unless confirmed in writing. Any insurance on goods is at the customer's expense.

Any claims for damages incurred in transit must be handled directly by your Company with the carrier concerned. All manufacturer's names, numbers, symbols or descriptions are for reference purposes only and are not intended to imply that the products are of that manufacture.

All claims made by overseas manufacturers as to the performance of their products are not necessarily upheld by our Company.

### Placement of orders

If your order is phoned, faxed or emailed into our warehouse, please state part numbers. If part numbers are not stated, our Company will not be responsible for supply of incorrect goods where only a description is given.

### Product changes

Due to constant product modifications and updating, specifications may vary on some products.

Copyright © 2010

Hardiman Auto Supplies Pty Ltd

The contents of this publication are copyright and cannot be reproduced without written permission from Hardiman Auto Supplies Pty Ltd



**Redline**  
PERFORMANCE



*Redline*

are registered trademarks of  
Hardiman Auto Supplies Pty Ltd



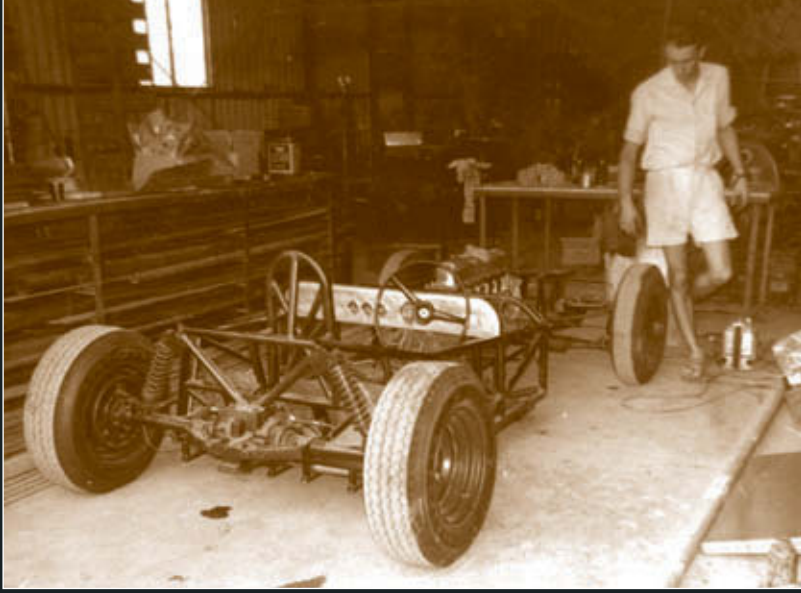

▲ Terry Hardiman in the early 1960s working on his second Hill Climb Special. He raced the car in hill climbs, short circuit and sprints for three years.



▲ The first speed shop in NSW opened in Beverly Hills in 1963



▲ The same shop enlarged in 1973

## the Hardiman story

**Hardiman Auto Supplies Pty Ltd** had its beginnings in 1959 as **Hardrowl Speed Equipment**. This business was run as a partnership by two apprentice tool makers, Terry Hardiman and Ian Rowley.

Manufacturing commenced making lowering kits, panhard rods, traction rods, floor gear shift conversions, sports air filters, induction manifolds, ram tubes and the like. In 1963 the first speed shop in NSW was opened in the Sydney suburb of Beverly Hills.

The Hardrowl partnership was dissolved in 1966 and Terry and Sylvia Hardiman commenced trading as **Hardiman Auto Supplies Pty Ltd**.

In 1972, the original speed shop in Beverly Hills was expanded to more than four times its original size. Manufacturing continued and additional product lines added. Importing from the USA commenced and the wholesale business continued to expand.

The retail business was sold in 1981, but the Beverly Hills property was retained and is still owned today. The manufacturing and wholesale business was then relocated to Ashford Avenue, Milperra. 1984 saw the move to larger purpose-built premises in Bullecourt Avenue, Milperra, where it still is today.

Product is imported from the USA, UK, India and Taiwan. Manufactured products are sold Australia-wide and exported to the UK, New Zealand and Indonesia. Under the Redline trademark, Hardiman Auto Supplies manufactures the largest range of inlet manifolds, carburettor adaptors and associated linkage components in the southern hemisphere.

Hardiman Auto Supplies was purchased by Terry and Sylvia's son Mark Hardiman and his wife Deborah in September 2005. Mark and Deborah have been expanding the product range and services of Hardiman Auto Supplies since.

▼ Anthony Robson with his Formula Ford







▲ Ian Mackay with his Speedway Midget and pit crew at Liverpool Speedway

▼ Shane Hardiman's LJ Torana powered by a 186 engine with triple 45 DCOE Weber carburetors, runs 14.1 seconds for the standing 1/4 mile



▲ Eddie Stipanovich with his Holden Monaro at Castlereagh drag strip

▼ Robbie Farr in action in his sprint car at Parramatta Speedway. Photo by Phil Jordison







▲ Garry Quigley and Andrew Holdsworth with the Ford Falcon at Targa Tasmania



▲ Jeff Barnes with the high-tech Pontiac Trans-Am sports sedan

▼ Gary Willmington and Jeff Barnes at Bathurst 1994 with the Ford Falcon







▲ Michael Baghdadi's Gemini, powered by a 2.2 litre engine.  
Standing 1/4 mile time 11.9 seconds at 109 mph. This car is a normal aspirated engine  
(it is not turbo charged or supercharged or running nitrous oxide injection)



▲ Graham Morahan with his much modified Chevy powered Holden Torana sports sedan

▼ John Williams' small block Chevy fuel-injected race boat in full flight. Photo by Phil Channing





	page
<b>carburettor spares</b>	
carburettor gasket & renew kits	2
Holley carburettor spare parts	3-7
miscellaneous carburettor spare parts & accessories	8
<b>carburettor adaptors</b>	
carburettor conversions for fitment to stock inlet manifolds	9-12
adaptor applications	13
carburettor adaptors	14-18
adaptor accessories	19
<b>inlet manifolds</b>	
quick reference	20-21
to suit 4 cylinder engines	22-24
to suit 6 cylinder engines	25-26
to suit V8 engines	27-29
<b>suggested jet settings</b>	
DCOE Weber	30-31
<b>fuel components</b>	
fuel lines & fittings	32-34
<b>carburettor linkages</b>	
throttle control components	35-40
throttle cables	41
carburettor linkage kits	42-46
<b>air filters</b>	
sports air cleaner base identification chart	47
airforce1 reusable cotton filters	48-51
airforce1 reusable panel filters	52
sports air cleaners & velocity stacks	53-55
sports air cleaner accessories	56-58
ram tubes	59
ram air sox	60
<b>covers &amp; housing</b>	
rocker covers	61-64
rocker cover accessories	65-67
thermostat housings & accessories	68
engine & transmission oil pans	69
miscellaneous	70
<b>engine accessories</b>	
dipsticks	71
aluminium alloy pulleys & Gilmer drives	72
studs, screws, nuts & bolts	73-74
ignition lead support kits	75-76
miscellaneous	77-79
<b>gaskets</b>	
carburettor base gaskets	80-82
inlet manifold gaskets	83
exhaust header gaskets	84-86
<b>gauges</b>	
race gauges	87
marine gauges	88
<b>instrument fittings</b>	
to suit Pricol & Smiths Gauges	89-90
<b>general accessories</b>	
ignition	91
hood pin kits & accessories	92
gear shift knobs	93
door lock knobs	94
miscellaneous	95-97
<b>appendices</b>	
reference list of vehicle model to year of manufacture	98
index	99

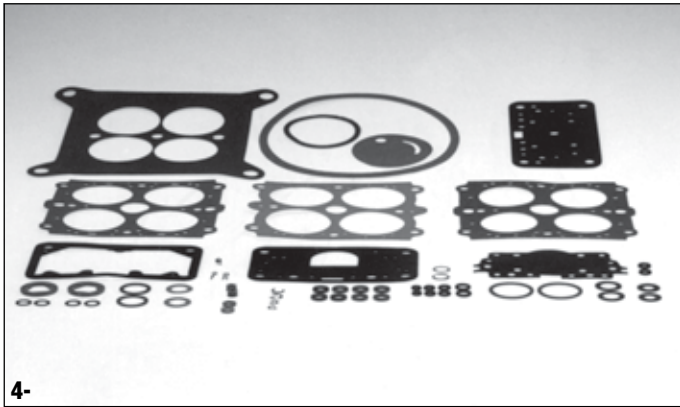

4-

**Carburettor Gasket Kits to suit Holley 2 & 4 Barrel**

Part no.	Description	No. of Barrels	Model no.
4-350	Gasket Kit suit 8007,1-191, 9776, 1850, 4452-1, 1-131, 3310-2	4	4160
4-353	Gasket Kit suit 7448, 1-192, 2-205	2	2300

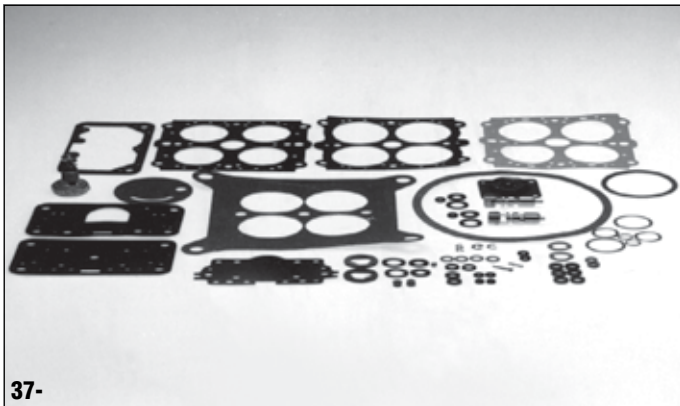

37-

**Renew Kits to suit 2 & 4 Barrel Carburetors - Holley, Rochester, Weber**

Part no.	Description	No. of Barrels	Model no.
37-151	Renew Kit suit 4bbl Carter Thermo-Quad fitted to Ford V8 1978-on	4	
37-1542	Renew Kit suit 8007, 1-191, 1848-1, 9776, 1850-2, 4452-1, 1-131, 9834, 3310-2 Holley Carburetors	4	4160
37-1543	Renew Kit suit 7448, 1-192, 2-205 Holley Carburetors	2	2300
37-357	Renew Kit suit 3310, 4118 Holley Carburetors	4	4150
37-358	Renew Kit suit 1-238, 1-239 Holley Carburetors	2	5200, 5210
37-359	Renew Kit suit 4412 Holley Carburettor	2	2300
37-1544	Renew Kit suit 4776, 4777, 4778, 4779, 4780, 4781 Holley Carburetors	4	4150
37-362	Renew Kit suit 7456 Holley Carburettor	4	4360
37-363	Renew Kit suit 7397 Holley Carburettor	4	4175
37-368	Renew Kit suit 6210, 8679 Holley Carburetors	4	4165
37-369	Renew Kit suit 6910, 650 & 800cfm Spread Bore Holley Carburetors	4	4165
37-370	Renew Kit suit 1050 & 1150cfm Holley Dominator Carburetors	4	4500
37-384	Renew Kit suit 4224, 660cfm Centre Shooter Holley Carburettor	4	4160
37-601	Renew Kit suit 4bbl Rochester Quadrajjet Carburettor Fitted to 1969-75 Holden V8	4	
37-602	Renew Kit suit 4bbl Rochester Quadrajjet Carburettor Fitted to 1976-79 Holden V8	4	
37-603	Renew Kit suit 4bbl Rochester Quadrajjet Carburettor Fitted to 1980-on Holden V8	4	
37-800	Renew Kit suit 32-36 DGV Weber Carburettor	2	
37-805	Renew Kit suit 40-45 DCOE Weber Sidedraught Carburettor	2	
37-834	Renew Kit suit 40-48 IDF Weber Downdraught Carburettor	2	
37-844X	Renew Kit suit ADM Weber 2bbl Downdraught Carburettor*	2	
WE-829	Renew Kit suit 40 DFAV Weber Carburettor	2	
WE-838	Renew Kit suit 42 DCFN Weber Carburettor	2	
WE-848	Renew Kit suit 48 IDA Weber Carburettor	2	

\*ADM Weber Carburettor used on X-Flow Falcon 6cyl.



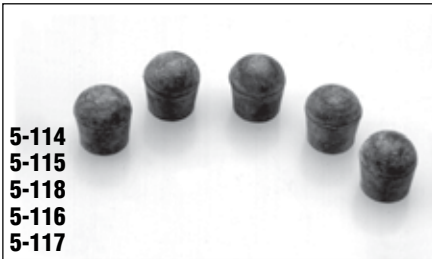

5-114  
5-115  
5-118  
5-116  
5-117

5-114 **Blanking Rubbers** 3/16" id. Pack of 5  
5-115 **Blanking Rubbers** 1/4" id. Pack of 5  
5-118 **Blanking Rubbers** 5/16" id. Pack of 5  
5-116 **Blanking Rubbers** 3/8" id. Pack of 5  
5-117 **Blanking Rubbers** 1/2" id. Pack of 5

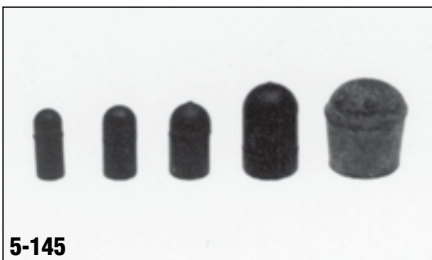

5-145

**Blanking Rubbers**  
3/16", 1/4", 3/8" id.  
2 of each in pack



8-25  
8-35  
8-45  
8-55  
8-65  
8-75  
8-85  
8-95  
8-105

8-25 **Power Valve** size 2.5 with Gasket  
8-35 **Power Valve** size 3.5 with Gasket  
8-45 **Power Valve** size 4.5 with Gasket  
8-55 **Power Valve** size 5.5 with Gasket  
8-65 **Power Valve** size 6.5 with Gasket  
8-75 **Power Valve** size 7.5 with Gasket  
8-85 **Power Valve** size 8.5 with Gasket  
8-95 **Power Valve** size 9.5 with Gasket  
8-105 **Power Valve** size 10.5 with Gasket  
Each are sold as a pack of 1



26-36

**Power Valve Plug with Gasket**  
Pack of 1



15-40K

**Mixture Screws & Gaskets**  
Suit most Holleys (not Spreadbores).  
Pack of 2

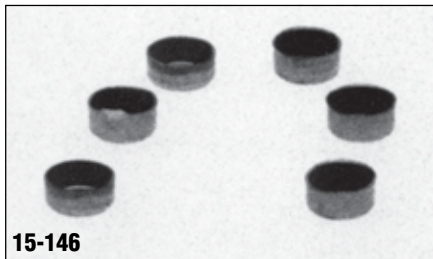

15-146

**Brass Welsh Plugs 1/4"**  
Suit Holley metering block.  
Pack of 6

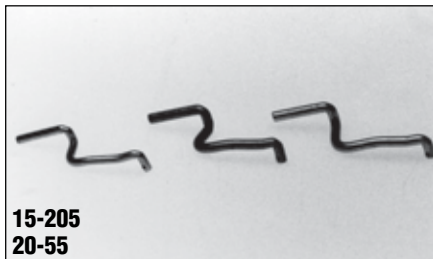

15-205  
20-55

**Throttle Shaft Connecting Link**  
Primary to Secondary 4 Barrel.  
15-205 Suits Model No. 4160  
20-55 Suits Model No. 4175  
Each are sold as a pack of 1

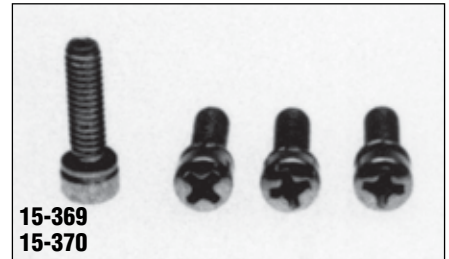

15-369  
15-370

**Accelerator Pump Cover Screws**  
15-369 27/64" long. Pack of 4  
15-370 35/64" long. Pack of 4

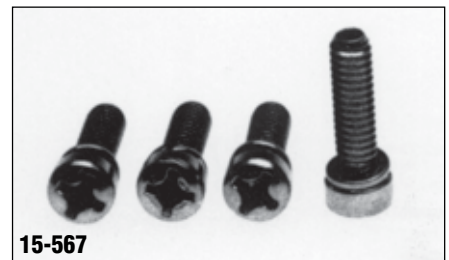

15-567

**Throttle Body Screws**  
Pack of 4



15-645  
15-646

**Fuel Bowl Screws**  
15-645 1 7/8" long suit Models 4160, 4175.  
Pack of 4  
15-646 2 1/2" long suit Models 4150, 4165.  
Pack of 4



**15-647**

**Standard Fuel Pump Discharge Screw**  
Pack of 1

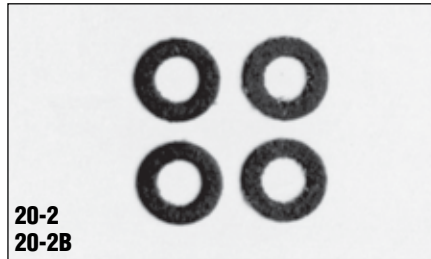

**20-2**  
**20-2B**

**Fuel bowl screw gaskets**  
**20-2** Pack of 20  
**20-2B** Pack of 100



**20-29**  
**20-29B**

**Primary metering block gasket**  
Suit 7448, 1850, 3310 etc.  
**20-29** Pack of 5  
**20-29B** Pack of 50

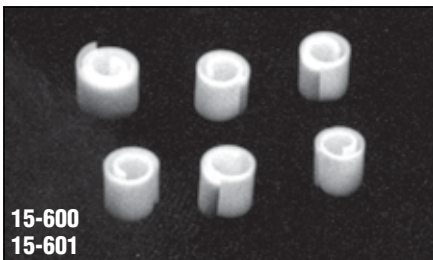

**15-600**  
**15-601**

**Teflon Throttle Bushes**  
**15-600** Small diameter. Pack of 10  
**15-601** Large diameter. Pack of 10



**20-4**  
**20-4B**

**Air Cleaner Gasket rings**  
5 1/8" diameter.  
Suit Holley 2 & 4 bbl carburetors etc.  
**20-4** Pack of 5  
**20-4B** Pack of 25



**20-30**  
**20-30B**

**Secondary metering plate & bowl gasket**  
Suit 1848-1, 1850, 4452 etc Holley squarebore carbs.  
**20-30** Pack of 5  
**20-30B** Pack of 50

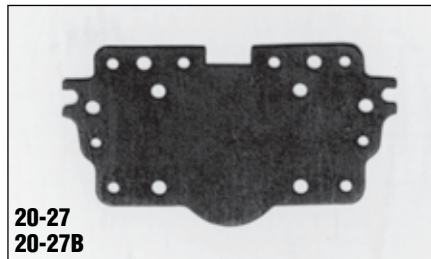

**20-27**  
**20-27B**

**Secondary metering plate gasket**  
Suit 1850, 1848-1, 4452 etc.  
**20-27** Pack of 5  
**20-27B** Pack of 50

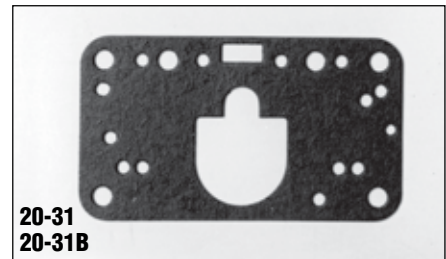

**20-31**  
**20-31B**

**Primary metering block gasket**  
Suit 6210, 7397 etc spreadbore Holley carbs.  
**20-31** Pack of 5  
**20-31B** Pack of 50

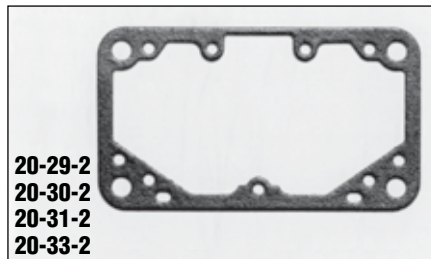

**20-29-2**  
**20-30-2**  
**20-31-2**  
**20-33-2**

**Blue non-stick bowl & Metering block gaskets**  
**20-29-2** Metering block gasket. Pack of 5  
**20-30-2** Secondary metering plate & bowl gasket. Pack of 5  
**20-31-2** Primary metering block gasket. Pack of 5  
**20-33-2** Bowl gasket. Pack of 5

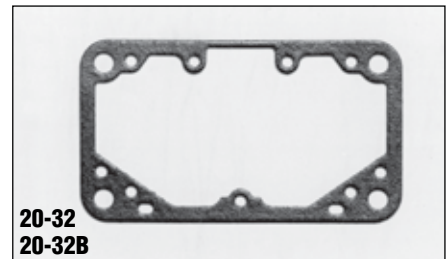

**20-32**  
**20-32B**

**Primary fuel bowl gasket**  
Suit 6210, 7397 etc spreadbore Holley carbs.  
**20-32** Pack of 5  
**20-32B** Pack of 50



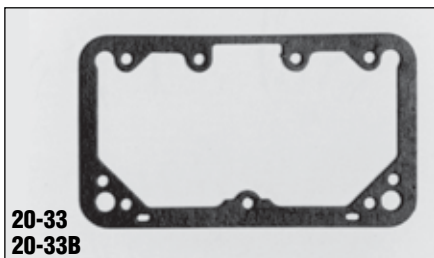

**20-33**  
**20-33B**

**Primary fuel bowl gasket**  
Suit 7448, 1850, 1848-1, 3310 etc  
**20-33** Pack of 5  
**20-33B** Pack of 50

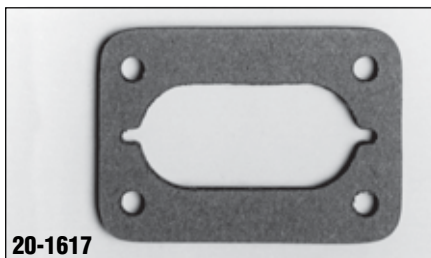

**20-1617**

**Heat Insulator 2bbl WW Stromberg Carburettor**  
Pack of 1



**23-41**

**Accelerator pump Check Valve**

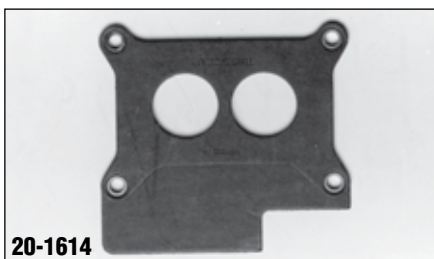

**20-1614**

**Heat Insulator 2bbl Holley Carbs**  
7448, 2-205 etc  
Pack of 1



**20-37**  
**20-37B**

**Fuel bowl Transfer Tube O rings**  
**20-37** Pack of 2  
**20-37B** Pack of 50

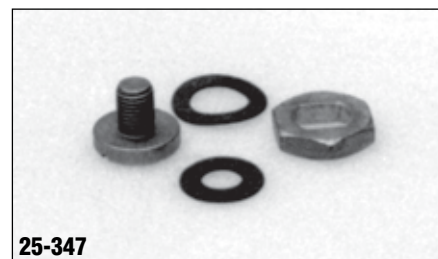

**25-347**

**Needle & Seat Hardware kit**  
Pack of 1

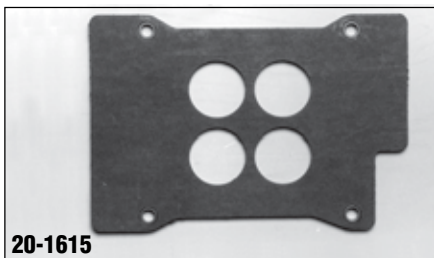

**20-1615**

**Heat Insulator 4bbl Holley Squarebore Base**  
Pack of 1



**23-38**  
**23-38B**

**Accelerator pump transfer tube O ring seal**  
**23-38** Pack of 2  
**23-38B** Pack of 100



**25-504**  
**25-515**

**Needle & Seat**  
Suit squarebore Holley  
**25-504** .110 size Viton type  
**25-515** .130 size steel type  
for hi-performance fuels  
Each sold as a pack of 1

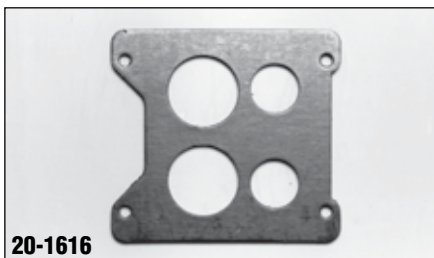

**20-1616**

**Heat Insulator 4bbl Holley Spreadbore Base**  
Pack of 1

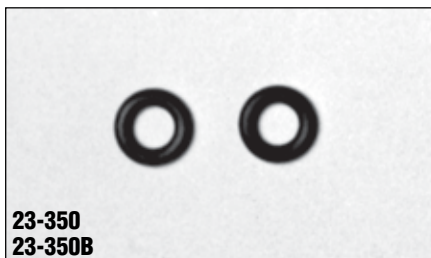

**23-350**  
**23-350B**

**Needle & Seat O ring seal**  
**23-350** Pack of 2  
**23-350B** Pack of 100

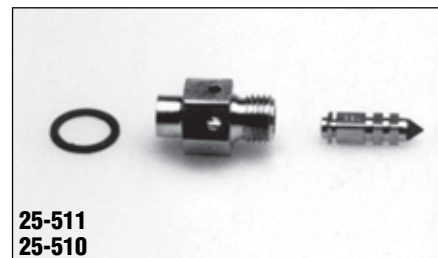

**25-511**  
**25-510**

**Needle & Seat**  
Suit spreadbore Holley  
**25-511** .0785 size  
**25-510** .110 size  
Each sold as a pack of 1

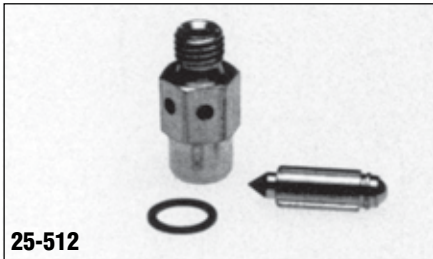

**25-512**

**Needle & Seat**

Suit 2bbl 1-238, 1-239 & Weber Carburettors 32/36 DGV.  
Pack of 1

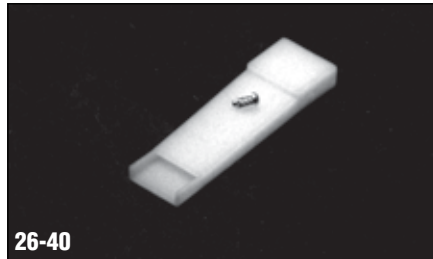

**26-40**

**Fuel bowl Vent Baffle**

Extends bowl vent path over fuel. Easy to install into the metering block, this baffle will provide continuous venting action in the primary bowl under severe acceleration.  
Pack of 1



**64-4**

**Vacuum Secondary Diaphragm**

Suit Holley 1850, 3310, 4452, 7397.  
Pack of 1

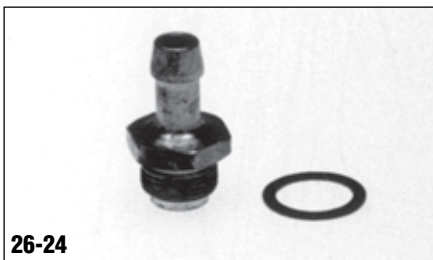

**26-24**

**Holley Fuel Fitting 5/16" diameter**

Suit 1850 etc.  
Pack of 1

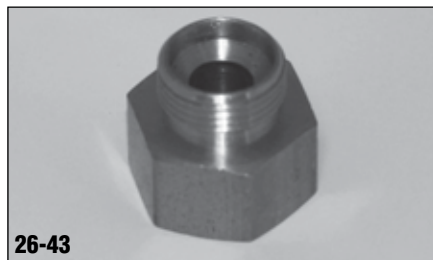

**26-43**

**Fuel fitting 3/8" line suit Holley**

Pack of 1

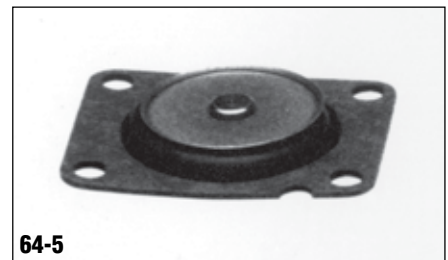

**64-5**

**Accelerator Pump Diaphragm 30cc type**

Pack of 1



**26-25**

**Holley Swivel style Fuel Fitting**

Suit 5/16" diameter hose. Suit Holley carbs 1850 etc.  
Pack of 1



**62-500**

**Holley Brass Moraine genuine fuel filter**

Pack of 1

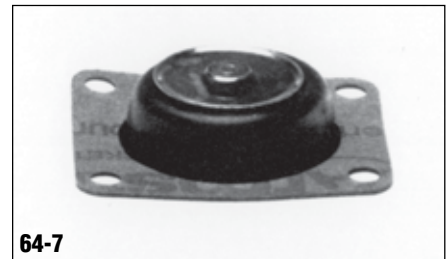

**64-7**

**Accelerator Pump Diaphragm 50cc type**

Pack of 1



**26-26**

**26-26 Holley Fuel Fitting 3/8"**  
Inverted Flare fitting. Pack of 1

**26-27 Holley Fuel Fitting 5/16"**  
Inverted Flare fitting. Pack of 1

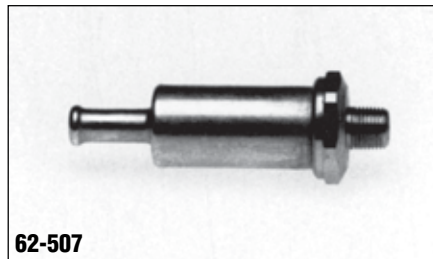

**62-507**

**Holley all-steel 1/8" gas screw-in Fuel Filter**

Suit 5/16" hose.  
Pack of 1



**108-1**

**Fuel inlet gasket washer, 9/16" diameter**

Pack of 50





**108-3**  
**Power Valve gasket**  
Pack of 50

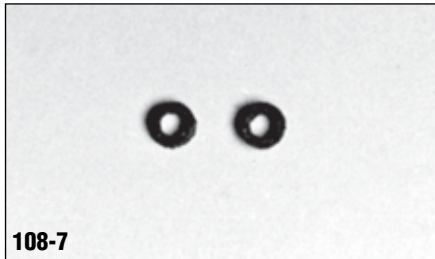

**108-7**  
**Mixture Screw Cork Seals**  
Pack of 50



**134-13**  
**Fuel Bowl Sight Plugs & Gaskets**  
Pack of 2



**108-4**  
**Power Valve Plug gasket**  
Pack of 20



**108-8**  
**Fuel inlet gasket, 7/8" diameter**  
Pack of 50

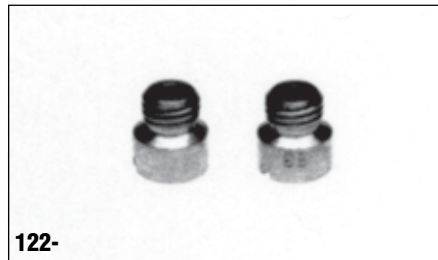

**122-**  
**Holley Main Jets**  
Size 49 to 100.  
Pack of 2



**108-5**  
**108-6**  
**Needle & Seat washer**  
108-5 Located under Hex nut. Pack of 50  
108-6 Located under Lock screw. Pack of 50



**108-9**  
**Pump Discharge Nozzle Gaskets**  
Bulk Pack of 50

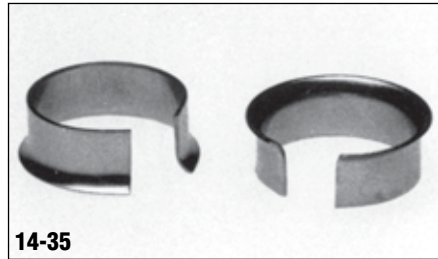

**14-35**  
**Venturi Sleeves**  
To suit 7448 Holley 350cfm 2 Barrel Carb. When fitted, these sleeves increase air speed through the carburettor venturi and help prevent flat spots, particularly on small cubic inch engines. Increased air speed through the carburettor also assists low down acceleration. Main jet sizes must be reduced to maximise fuel economy and prevent over-rich idle. Metering block power valve holes can also be swaged down from 0.060" dia. to 0.030 dia.  
Pack of 2

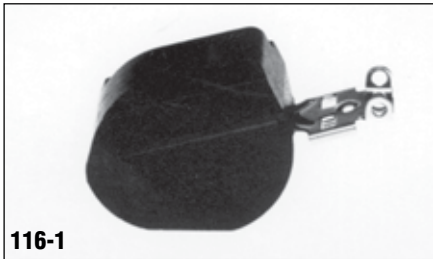

**116-1**

**Nitrophyl (plastic) Float**  
Side pivot mount. Suits Holley carbs.  
Pack of 1

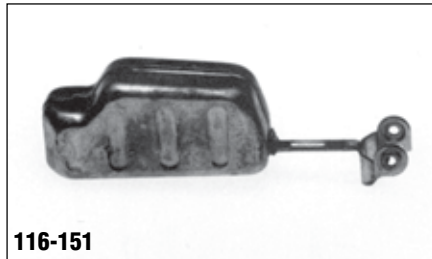

**116-151**

**Brass Float**  
Suit Carter Thermo-Quad carb,  
Ford 302-351 Cleveland V8 1978-on.  
Pack of 1

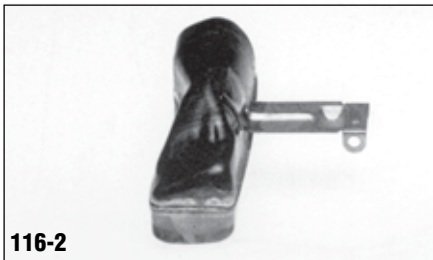

**116-2**

**Brass Float**  
Centre pivot mount. Suit Holley carbs 7448,  
3310 etc.  
Pack of 1

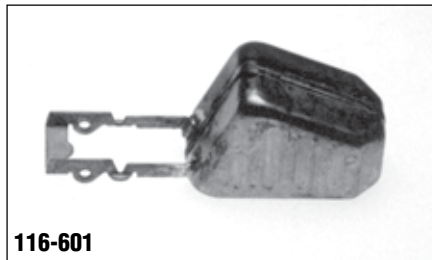

**116-601**

**Brass Float**  
Suit Rochester Q-Jet carb,  
Holden V8 1969-1975.  
Pack of 1

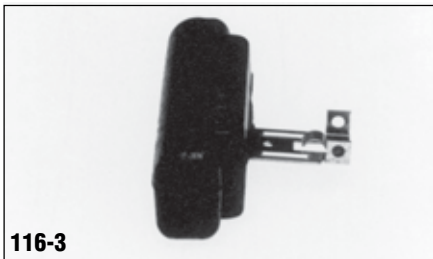

**116-3**

**Nitrophyl (plastic) Float**  
Centre pivot mount. Suit Holley carbs 7448,  
3310 etc.  
Pack of 1



**116-602**

**Brass Float**  
Suit Rochester Q-Jet carb,  
Holden V8 1976-1979.  
Pack of 1



**116-5**

**Brass Float**  
Suit Rochester Q-Jet carb,  
Holden V8 1980-1985.  
Pack of 1



**H116-6**

**Brass Float**  
Suit Holley Model 4360.  
Pack of 1

Vehicle make & model	Carburettor	Adaptor	Air filter	Linkage kit
<b>Alfa Romeo</b>				
Giulia, Sud TI, 1300TI	32/36DGV Weber	not required	16-42	
Alfa Romeo & Alfased with 1bbl carb	32/36DGV Weber	10-214	16-42	42-21
<b>Audi</b>				
With 2bbl Weber downdraught or Solex	32/36DGV Weber	not required	16-42	
<b>BMW</b>				
2002 (1974-76) 320 2 litre (1975-76) with 2bbl Weber downdraught or Solex carburettor	32/36DGV Weber	not required	16-42	
<b>Chevrolet</b>				
4cyl Luv (Isuzu) 1600cc	32/36DGV Weber	10-112	16-19	42-21
6cyl models with 1bbl carburettor	320 or 350cfm Holley	10-502	16-9	
8cyl models with 2bbl Rochester carburettor	320 or 350cfm Holley	10-233	16-13	original
8cyl models with 4bbl Quadrajel carburettor	4bbl Holley squarebore	10-553/4	16-13	original
GM V6 imported engine 200-228ci	320 or 350cfm Holley	10-556	16-13	n/a
<b>Chrysler/Dodge see Mitsubishi</b>				
<b>Citroen</b>				
CX2200, CX2400 with 2bbl carburettor	32/36DGV Weber	10-112	16-19	42-21
with 1bbl carburettor	32/36DGV Weber	10-214	16-19	42-21
<b>Daihatsu</b>				
F10L, 4x4 958FE 1976-1977 F20L, F20J, 1600 12R, DV23T, V, DV17T, V35 truck, 2000cc 5R engine, Charade G10, G11R 1980- (carb stud centres 80mm x 44mm)	32/36DGV Weber	10-112	16-42	42-21
Handivan L60V, 2cyl S60V, C65 1980 on, Delta Rocky F80, F85, 3XC 1984 on (Carb stud centres 112mm x 51mm)	32/36DGV Weber	10-220	16-42	42-21
<b>Datsun see Nissan</b>				
<b>Fiat</b>				
with 1bbl carburettor	32/32DGV Weber	10-214	16-19	42-21
with 2bbl Weber or Solex except 850 Coupe	32/32DGV Weber	not required	16-19	42-21
850 Sports Coupe	32/32DGV Weber	10-212	16-19	42-21
128 Coupe, X1/9, Mirafiori 131, 132	32/32DGV Weber	10-112	16-19	42-21
<b>Ford 4cyl</b>				
Escort 1100, 1300 1970-76, 1600, 2000 1976 to 1981 & Cortina 1600, 2000 all with 1bbl carb	32/36DGV Weber	10-214	16-42	42-21
if replacing 1bbl carb with 1bbl Weber	341CH Weber 1bbl	not required	original	original
4cyl models with 2bbl Weber or Autolite	32/36DGV Weber	not required	16-42	42-21
Laser & Meteor 1300-1500 KA, KB 1981-85	32/36DGV Weber	10-216	16-42	42-21
<b>Ford 6cyl</b>				
Falcon 6cyl & Cortina TC, TD 1960-75	32/36DGV Weber	10-2222	16-19	n/a
Falcon 6cyl & Cortina TC, TD 1960-75	320 or 350cfm Holley	10-231	16-9	n/a
Falcon 6cyl XC, XD & Cortina X-flow cast iron & alloy heads with 1bbl carb 1976-81	32/36DGV Weber	10-2215	16-19	n/a
Falcon 6cyl XC, XD & Cortina X-flow cast iron & alloy heads with 1bbl carb 1976-81	320 or 350cfm Holley	10-230	16-35	original
Falcon 6cyl 250ci 2V with WW Stromberg	320 or 350cfm Holley	10-233	16-9	n/a
Ford Capri V6	320 or 350cfm Holley	10-237	16-9	original

**Note**

Ford Falcon 6cyl Alloy Head with 2bbl ADM Weber. If a 2 barrel Holley carburettor is to be fitted, a Redline inlet manifold must be used - Part No. 12-70. If an adaptor is used to fit a 2bbl Holley, the carburettor will hit the rocker cover.



Vehicle make & model	Carburettor	Adaptor	Air filter	Linkage kit
<b>Ford Falcon V8</b>				
XR-XB fitted with 2bbl carburettor	4bbl Holley squarebore	10-515	16-13	42-10K
XR-XB fitted with 2bbl carburettor	2bbl Holley 320-350	10-233	16-13	
XC, XD, XE V8 fitted with Carter Thermo-Quad 4bbl to take 2bbl Holley	320 or 350cfm 2bbl Holley	10-555	16-13	42-11K
XC, XD, XE V8 Carter Thermo-Quad to 4bbl Holley	4bbl Holley squarebore	10-550	16-13/16-14	42-10K
XC, XD, XE V8 Carter Thermo-Quad to 4bbl Holley	4bbl Holley squarebore	10-552 with PCV tube	16-13/16-14	42-10K
XC, XD, XE V8 Carter Thermo-Quad to 4bbl Holley	4bbl Holley spreadbore	10-551 without PCV tube	16-13/16-14	42-10K
<b>Note</b>				
<i>On some V8 XR-XB 2bbl manifolds, use 10-240 spacer if a 2bbl Holley 500cfm 4412 carb is fitted, so the accelerator pump will clear the manifold.</i>				
<i>Ford Falcon V8 models before XC- on do not require adaptors, as 2bbl &amp; 4bbl Holley carburettors will bolt directly onto 2bbl &amp; 4bbl Ford manifolds, standard carb bolt pattern. If a 4bbl carb is to be fitted to V8 XR-XB 2bbl manifolds, use 10-515 adaptor.</i>				
<i>Check bonnet clearance with all 6cyl and V8 Ford conversions.</i>				
<b>Holden 4cyl</b>				
4cyl models with 1bbl carburettor	32/36DGV Weber	10-214	16-42	42-21
Astra 1488cc 1984 on	32/36DGV Weber	10-2236	16-42	42-21
Gemini 1600, 1800, 2000 OHC (Isuzu engine)*	32/36DGV Weber	10-112	16-42	41-878
Torana 4cyl TA 1300, 1600, 1750 1971-75*	34ICH 1bbl Weber	not required	16-4	original
Torana 4cyl LC, LJ, TA 1600, 1750cc	34ICH 1bbl Weber	not required	16-4	original
Torana Sunbird 1900cc OHC Opel engine Use original heat insulator under carburettor	32/36DGV Weber	not required	16-42	42-21
Sunbird, Camira & Commodore 4&6cyl fitted with 2bbl Rochester Varijet carburettor	32/36DGV Weber	10-218	16-42	42-21
<i>* Use original heat insulator under carburettor, float bowl of Weber to face firewall.</i>				
<b>Holden 6cyl</b>				
EH-HG 149-186 1964-70 with 1bbl carby	32/36DGV Weber	10-510	16-19	
EH-HG 149-186 1963-70 with 1bbl carby	320 or 350cfm Holley	10-501	16-9	42-24
Torana LC, LG 1969-73 with 1bbl carby	32/36DGV or 38DGMS 320 or 350 Holley	10-510 10-501	16-19 16-19	42-21 42-36
186S & GTR Torana with 2bbl WW Stromberg carburettor	32/36DGV- 38DGMS 320 or 350cfm Holley	10-2216 10-233	16-19 16-9	42-21 42-24
HQ-HJ 202 1971-75 1bbl with 3/8" studs	32/36DGV Weber	10-512	16-19	42-21
HQ-HJ 202 1971-75 1bbl with 3/8" studs	320 or 350cfm Holley	10-502	16-9	42-22HQ 42-65HJ*
HX-VB 202 1976-79 1bbl with 5/16" studs	32/36DGV Weber	10-513	16-19	42-21
HX-VB 202 1976-79 1bbl with 5/16" studs	320 or 350cfm Holley	10-503	16-9	42-65*
WB 202 & Commodore with blue/black engine 1980-85 fitted with 2bbl Rochester Varijet	320 or 350cfm Holley or 38DGMS Weber	10-219 10-218	16-9 16-19	42-66** 42-21
GM V6 imported engine 200-228ci	320 or 350cfm Holley	10-556	16-13	n/a
<i>* 42-65 cable bracket should be used with Holden V8 or Torana V8 throttle cable</i>				
<i>**42-66 cable bracket should be used with Commodore V8 throttle cable</i>				
<b>Holden V8</b>				
HK 307ci Chev V8	320 or 350cfm Holley	10-233	16-13	original
HK-HQ 327-350ci Chev V8	4bbl squarebore Holley	10-553/4	16-13	original
HT 253ci V8 with early 2bbl manifold	320 or 350cfm Holley	10-187	16-13	original
HT-HZ 253ci V8 with 2bbl carburettor	38DGMS Weber	10-2216	16-19	original
HG-HZ 253ci V8 with 2bbl carburettor	320 or 350cfm Holley	10-233	16-13	original
HG-HZ 253ci V8 with 2bbl carburettor	4bbl squarebore Holley	10-515	16-13	original
Torana LH, LX. Holden HG-HZ 308 with 4bbl carb	4bbl squarebore Holley	10-553/4	16-13	original
Torana & Commodore with 2bbl carburettor	320 or 350cfm Holley	10-233	16-13	original
Torana & Commodore with 4bbl carburettor	320 or 350cfm Holley	10-555	16-13	original
Torana & Commodore with 4bbl carburettor	4bbl squarebore Holley	10-553/4	16-13	original
Torana & Commodore with 4bbl carburettor	4bbl spreadbore Holley	not required	16-13	original
WB & Commodore 253 V8 4bbl carburettor	4360 450cfm 4bbl Holley	not required	16-13	original
<b>Honda</b>				
Civic 1200, 1500, Accord, Prelude (Hitachi 2bbl) if Hitachi carb flanges face east-west use	32/36DGV Weber	10-212 10-2236	16-42 16-42	42-21 42-21



# carburettor adaptors

## carburettor conversions for fitment to stock inlet manifolds

Vehicle make & model	Carburettor	Adaptor	Air filter	Linkage kit
<b>Isuzi</b>				
Bellet, Gemini, Luv	32/36DGV Weber	10-112	16-42	42-21
<b>Jeep</b>				
with AMC 232 6 cylinder engine	320 or 350 Holley	10-233	16-13	
<b>Lada</b>				
Niva 1600 4WD 1985 on	32/36DGV Weber	not required	16-42	
<b>Lancia</b>				
fitted with 2bbl Weber or Solex carburettor	32/36DGV Weber	not required	16-42	
<b>Landrover</b>				
2.25 litre series 2A, 3 1967-1983 with 1bbl carb	34ICH Weber	not required	16-4	
4 cylinder Landrover with 2bbl carb	32/36DGV Weber	10-512	16-42	42-21
<b>Leyland</b>				
P76 V8	320 or 350 Holley	10-233	16-13	
P76 V8	38DGMS Weber	10-2216	16-42	
<b>Lotus</b>				
with Cortina or Renault engine	32/36DGV Weber	not required	16-42	42-21
<b>Mazda</b>				
1200, 1300,1400, 808, 323, RWD models 1968-78 Use original carb heat shield with adaptor	32/36DGV Weber	10-212	16-42	42-21
1500, 1600, 929, Capella, 121, 626, 808, 1800, 2000 1977-1983	32/36DGV Weber	10-112	16-42	42-21
1300,1500, 323 FWD models 1980-1985	32/36DGV Weber	10-216	16-42	42-21
<b>Mitsubishi/Chrysler 4cyl</b>				
Colt 1300, 1400, 1600, 1970-1988 fitted with a 2bbl Mikuni - Solex carb standard	180cfm Holley 2bbl	10-112	16-41	42-21
Cordia, Galant, Lancer, Satellite, 1973-1985 Sigma, Scorpion, Express L300 1300, Pajero, Canter, 1300, 1400, 1500, 1600, 1800, 2000, 2600, Magna 1985 on	180cfm Holley 2bbl	10-112	16-41	42-21
<b>Mitsubishi/Chrysler 6cyl</b>				
Chrysler 6cyl models with 1bbl carburettor	32/36DGV Weber	10-512	16-42	42-21
Chrysler 6cyl models with 1bbl carburettor	320 or 350cfm Holley	10-502	16-9	original
Chrysler 6cyl models with 2bbl carburettor*	320 or 350cfm Holley	10-233	16-13	original
Chrysler 6cyl models with 2bbl carburettor*	38DGMS Weber	10-2216	16-19	original
Chrysler 6cyl Hemi & Centura with 2bbl*	320 or 350cfm Holley	10-233	16-9	original
Chrysler 6cyl Hemi & Centura with 2bbl*	38DGMS Weber	10-2216	16-19	original
<i>*Valiant 6cyl AP6, VE, VF, VG, VH, VJ, CJ, VK, CK, CL, CM 1967-81 fitted with 2bbl Carter carburettor, standard</i>				
<b>Mitsubishi/Chrysler V8</b>				
Chrysler V8 all models with 2bbl carb*	320 or 350cfm Holley	10-233	16-13	original
Chrysler V8 all models with 2bbl carb*	38DGMS Weber	10-2216	16-19	original
Chrysler V8 all models with 4bbl carburettor	4bbl Holley	10-553/4	16-13	original
<i>*Valiant 8cyl AP6, VE, VF, VG, VH, VJ, CJ, VK, CK, CL, CM. 1967-81 fitted with 2bbl Carter carburettor, standard</i>				
<b>Morgan</b>				
with 2bbl Weber or Solex downdraught carb	32/36DGV Weber	not required	16-42	
<b>Nissan</b>				
1000, 1200, 120A, 120Y, 140Y, Sunny, 1500 A14, A15	32/36DGV Weber	10-212	16-42	42-21
1600, 180B, 200B, 240K, 240C, 260C, 280C, Stanza, Bluebird 1968-1986 L16, L18, L20	32/36DGV Weber	10-112	16-42	42-21
Pulsar 1.3, 1.4, 1.5, 1.6, N10, E13, N13, Series 3, 1980-1988	32/36DGV Weber	10-2236	16-42	42-21
Homer E20 Urvan, Cabstar, Patrol, Navara, Pathfinder 1969-1987 CA20	32/36DGV Weber	10-112	16-42	42-21
Prairie FWD E15, 1500 Vanette 1980-1983	32/36DGV Weber	10-2236	16-42	42-21
Nissan Patrol 4WD with 1bbl carb	320 or 350cfm Holley	10-502	16-9	n/a
Nissan Patrol 4WD MQ 1981 with 2bbl carb	320 or 350cfm Holley	10-232	16-9	n/a



Vehicle make & model	Carburettor	Adaptor	Air filter	Linkage kit
<b>Peugeot</b>				
models with 1bbl carburettor	32/36DGV Weber	10-214	16-42	42-21
<b>Rambler</b>				
fitted with Carter or Rochester 2bbl carb	320 or 350cfm Holley	10-233	16-13	
<b>Renault</b>				
all models with 1bbl carburettor	32/36DGV Weber	10-214	16-42	42-21
all models with 2bbl carburettor	32/36DGV Weber	not required	16-42	42-21
<b>Saab</b>				
all models with 1bbl carburettor	32/36DGV Weber	10-214	16-42	42-21
all models with 2bbl carburettor	32/36DGV Weber	not required	16-42	
<b>Subaru</b>				
1200, 1400, 1600, Sedan, Coupe, Wagon 2 & 4WD, 1973-79 & 1983 EA81 engine 1800cc & AE82	32/36DGV Weber	10-213	16-42	42-21
1600, 1800* Leone 4WD Dual Range 1979-83 1800 FA81 engine 1983-84	32/36DGV Weber	10-112	16-42	42-21
<i>*1800 engine manifold must be tapped out from 5mm to 8mm stud holes</i>				
<b>Toyota</b>				
Corolla, Corona, Celica, Crown, 1600cc Celica TA22 1971-75 with 80mm x 43mm stud centres	32/36DGV Weber	10-112	16-42	42-21
Corolla, Corona ST141, 25C, 225 Celica 2000, RA60, 21RC, Bunderra, Crown, Hi-Lux 18R, 18RC, 18RU 1974-1985 engine with 122mm x 56mm stud centres	32/36DGV Weber	10-217	16-42	42-21
Corolla 1100, 1200, 1300 1966-1984, 3K, 4K, 5K, Corolla Sprinter Seca 1983-1987 Celica, Corona 1.5, 1.6, 2 litre. 1964-1979 (Use original heatshield.) With 80mm x 43mm stud centres	32/36DGV Weber	10-112	16-42	42-21
Corolla, Corona, Celica, Crown (if fitted with Starfire 1900cc engine tap out stud holes to 8mm). Also fits 1600 1975-1976 Celica JA22, JA23 engines Corolla 12R, Hi-Lux 1Y to 4YC, Hi-Ace 2YC to 4Y 2 litre to 1986 & T18. (Use original heatshield.) With 112mm x 50mm stud centres	32/36DGV Weber	10-220	16-42	42-21
Celica 22R, RA655, 1990 Hi-Lux 2.4 litre 22R bolt pattern 50mm x 54mm x 97mm long	32/36DGV Weber	10-2224	16-42	42-21
Landcruiser 1965-1969	320 or 350cfm Holley	10-502	16-9	
Landcruiser 2F engine 1970-84 silver rocker cover Use original heatshield	320 or 350cfm Holley	10-232	16-9	
Landcruiser 3F engine 1984-90 black rocker cover	320 or 350cfm Holley	10-235	16-9	
<b>Triumph</b>				
With 1bbl downdraught carburettor	32/36DGV Weber	10-214	16-42	42-21
<b>VW</b>				
Beetle, Passat & Golf with 1bbl carburettor	32/36DGV Weber	10-214	16-42	42-21
Passat, TS Golf with 2bbl carburettor	32/36DGV Weber	not required	16-42	42-21
Passat and Golf with 1bbl carburettor	34ICH 1bbl Weber	not required		
VW Golf fully imported model with 2bbl carby	32/36DGV Weber	10-3203	16-42	
<b>Volvo</b>				
Fitted with 2bbl Weber or Solex carburettor	32/36DGV Weber	not required	16-42	42-21

### Note

When using Adaptor No. 10-214 the two adaptor holes may have to be elongated to fit some 4cyl inlet manifolds.

Four cylinder engines, in particular those that use exhaust heat transfer to manifold, must use a heat insulator spacer under the carburettor. This prevents overheating which causes flooding and vapour lock. Jamming of the carburettor throttle shaft may also occur.

For four cylinder automatic transmission vehicles, it may be necessary to alter existing linkages so that the transmission will function correctly.

The most commonly used downdraught Weber for these four cylinder conversions is the 32/36DGV, 32/36DGAV, 38DGMS. However in some applications you can also use the Holley model 5200 2bbl carburettor, 180cfm.

42-21 linkage kit is a universal cable linkage kit and alterations may have to be made to existing linkage so it will function correctly. Due to the extensive range of vehicle makes and models it is not possible to manufacture a linkage kit to suit every vehicle listed.

2 barrel Holley carburettors are available in 320cfm or 350cfm auto or mechanical choke.

4 barrel Holley carburettors are available in 390, 450, 465, 600, 750cfm auto choke vacuum secondary and some are available in mechanical choke.

4 Barrel Holleys are also available in 600, 700, 750, 800, 850cfm Double Pumper carburettors with mechanical secondary and manual choke.

Part no.	Application
10-233	320 or 350cfm Holley 2bbl to Holden 253, Chrysler 6cyl & 8cyl fitted with a 2bbl carb, Chevy 6cyl & 8cyl fitted with a 2bbl carb, 6cyl Jeep, P76, Chrysler Dodge 6cyl & 8cyl fitted with 2bbl carb
10-504	Blank adaptor can be drilled to fit a 1bbl manifold to take a 320 or 350cfm Holley
10-234	Blank adaptor can be drilled to fit a 2bbl manifold to take a 320 or 350cfm Holley
10-215	Adaptor can be drilled to fit most 1bbl manifolds to take a downdraught 32/36DGV Weber or 180cfm Holley 2bbl carburettor
10-237	Adaptor to fit 320 or 350cfm Holley on 2bbl Weber base manifold. eg: 32/36DGV, 38DGMS etc. Can also be reversed to fit Weber on Holley 2bbl manifold. Should not be fitted to Falcon XE on X-flow alloy head 6cyl engines
10-560	2" Hi-Spacer 4bbl squarebore pattern with 4 separate holes
10-507	1" Hi-Spacer 4bbl squarebore pattern with single open hole
10-508	1" Hi-Spacer 4bbl squarebore pattern with PCV pipe and single open hole
10-514	1/2" Hi-Spacer 4bbl squarebore pattern with PCV pipe and single open hole
10-509	2" Hi-Spacer 4bbl squarebore pattern with single open hole
10-515	Universal adaptor 450cfm spreadbore or 4bbl squarebore pattern to 2bbl manifold or 2bbl Holley or WW Stromberg to any 4bbl spreadbore or squarebore manifold
10-516	1" Hi-Spacer 4bbl spreadbore pattern
10-517	1" Hi-Spacer 4bbl spreadbore pattern with PCV pipe
10-553/4	Adaptor to fit 4bbl spreadbore pattern to 4bbl squarebore pattern manifold or 4bbl squarebore pattern to 4bbl spreadbore pattern manifold
10-240	1/2" Hi-Spacer 2bbl Holley 320 or 350cfm style carburettor
10-241	1/2" Hi-Spacer with PCV pipe 2bbl Holley 320 or 350cfm style carburettor
10-521	1/2" Hi-Spacer 4bbl squarebore pattern
10-556	320 or 350cfm Holley 2bbl carb to V6 GM 200/229ci engine
10-557	2 1/8" Hi-Spacer to fit from 4bbl squarebore pattern to Holley 4bbl Dominator pattern
10-558	10 Degree Marine Carburettor Wedge adaptor squarebore pattern
10-559	10 Degree Marine Carburettor Wedge adaptor squarebore pattern
10-9134	Phenolic Competition Spacer 1" thick squarebore pattern ported type
10-9135	Phenolic Competition Spacer 2" thick squarebore pattern ported type
10-9136	Phenolic Competition Spacer 1" thick squarebore pattern open type
10-9137	Phenolic Competition Spacer 2" thick squarebore pattern open type

**Note**

Due to vehicle manufacturers' constant changes to intake manifolds and carburettors it is impossible to guarantee that the Adaptors recommended will fit all makes and models shown on this list.

On engines that are larger than 2 litres, eg Falcon or Holden 6 cylinder, the larger 38DGMS Weber can be used instead of the 32/36 DGV Weber.

After fitment of any carburettor it is advisable to check that fuel mixture is correct, otherwise engine damage may occur. In most cases main jets and power valve change is all that is required.

The carburettor adaptors were not designed to fit ADM Weber carburettors which were factory fitted to the 6cyl Ford Cross Flow Alloy Head Falcon. However, if longer studs are used and in some cases the adaptor and carburettor linkage are modified, the setup will work okay.



Photo by Jon Van Daal

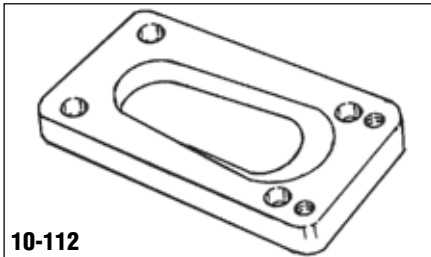

10-112

**Adapts Holley 1-238, 1-239 or Weber downdraught to the following vehicles:**

- Chevy Luv with 1600cc Isuzu engine
- Chrysler/Mitsubishi Colt, Galant, Lancer, Sigma
- Mitsubishi Express L300
- Citroen CX2200, CX2400
- Daihatsu with 80mm x 43mm carb base
- Datsun 1600, 180B, 200B, 240K, 260C, Bluebird, 510, 610.
- Fiat 125 coupe, X-19, 131
- Ford Courier with Mazda engine
- Holden Gemini 1600 OHC (Isuzu)
- Isuzu, Bellet, Gemini, Luv
- Mazda 1200, 1300, 808, 323 rear wheel drive model, 1500, 1800, 929, Capella 121, Mazda 1400
- Toyota Corolla, Corona, Celica, Crown, Celica 1600 TA22 1971-75

All with 80mm x 43mm carb base.

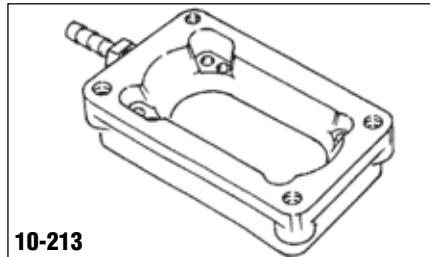

10-213

**Adapts Holley 1-238, 1-239 or Weber 32/36DGV downdraught to:**

- Subaru 1200, 1400, 1600
- Supplied with water intake fitting, gaskets and all necessary hardware.

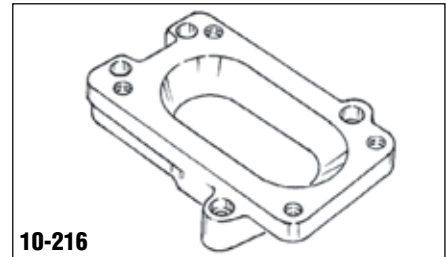

10-216

**Adapts Holley 1-238, 1-239 or Weber downdraught 32/36 to:**

- 1300, 1500 front wheel drive models of Ford Meteor, Ford Laser & Mazda 323

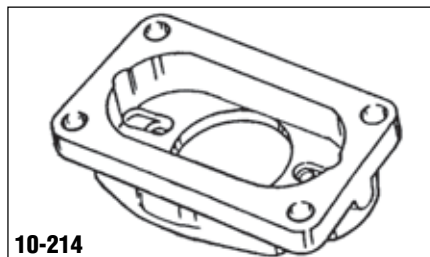

10-214

**Adapts Holley 1-238, 1-239 or Weber downdraught 32/36 to the following vehicles fitted with a 1bbl carb:**

- Audi models
  - Alfa Romeo, Sud
  - Ford Escort, Cortina
  - Holden 4cyl models
  - Peugeot models
  - Renault models
  - VW models
  - Most 4cyl engines with a 1bbl carb
- Note: On some manifolds it may be necessary to elongate the 2 bottom holes for correct fitment.

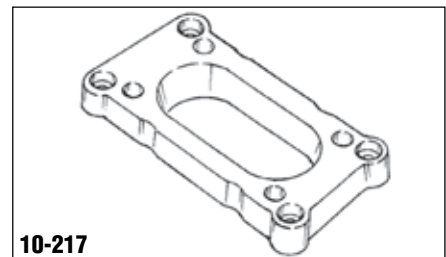

10-217

**Adapts Holley 1-238, 1-239 or Weber downdraught 32/36 to:**

- Toyota Corolla, Corona, Celica, Crown 18R, 18RC, 18RU (1974-79) engines
- Adaptor fits manifold with 122mm x 56mm stud centres.

Note: Use original bakelite heat shield to prevent carburettor overheating.

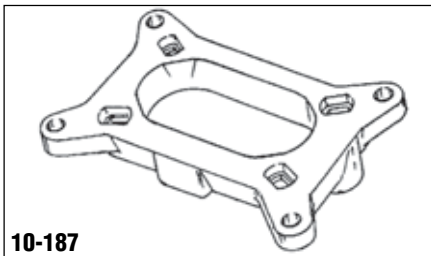

10-187

**Adapts 350cfm Holley to:**

- 253 V8 with early model intake manifold (water heated).

Adaptor is supplied with special heat insulator and all necessary hardware.

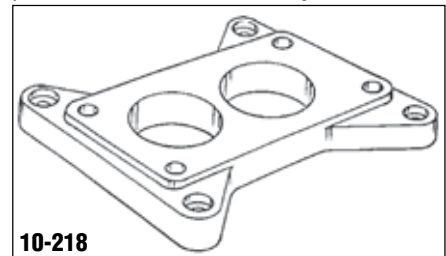

10-218

**Adapts Holley 1-238/9 or 32/36 Weber downdraught to:**

- Holden 4cyl Torana, Sunbird, Commodore with 2bbl Varijet carb
- Holden 6cyl blue/black motors fitted with 2bbl Varijet carb

Note: If fitted to 6cyl Holden engines, EGR blanking plate & gasket No. 42-17 is required.

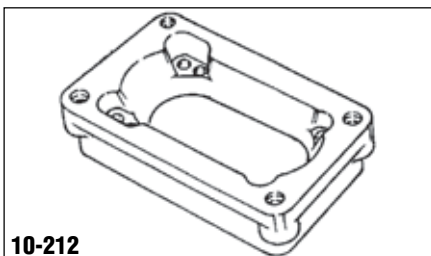

10-212

**Adapts Holley 1-238, 1-239 or Weber 32/36DGV downdraught to:**

- Datsun 100, 1200, 120A, 120Y, 140Y
- Fiat 850 Sports Coupe
- Honda Civic 1200, 1500, Accord, Prelude
- Mazda 1200, 1300, 808, 323 rear wheel drive

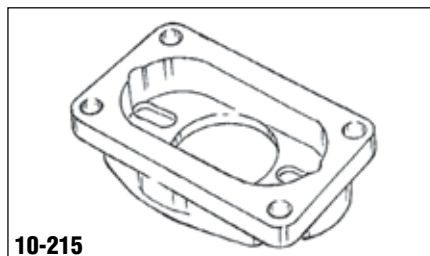

10-215

**Adapts Holley 1-238, 1-239 or Weber downdraught 32/36 to:**

Universal blank adaptor, can be fitted to most engines with 1bbl carb. This blank adaptor requires drilling to suit the bolt spacing of the original manifold.

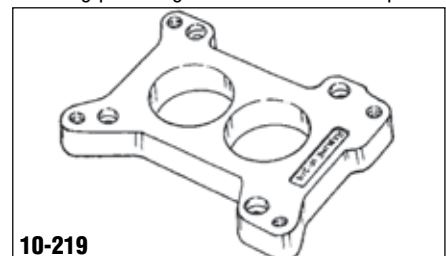

10-219

**Adapts 350cfm Holley carburettor to:**

- Holden 6cyl blue/black engine fitted with 2bbl Varijet carburettor
- Supplied with EGR gasket, plate & bolts & all necessary hardware.



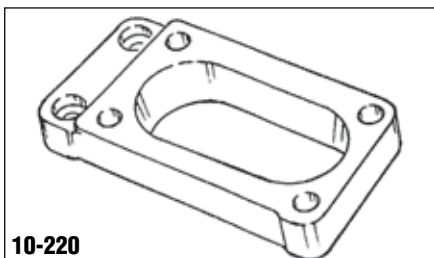

**10-220**

**Adapts Holley 1-238, 1-239 or 32/36 Weber downdraught to:**

- Toyota Corolla, Corona, Celica, Crown, Daihatsu. Note: If fitted with Starfire 1900cc engine, tap out manifold 4 stud holes to 8mm.
  - Toyota Celica 1600 TA22 - TA23 engines
  - Toyota Corolla TA18 engine, Corona 12R
  - HiLux 3Y, Hi-Ace, 2.0 litre Toyota to 1976
- Note: Use original heatshield.

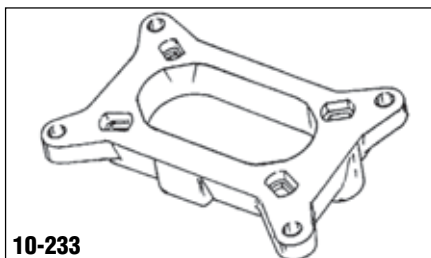

**10-233**

**Universal adaptor 350cfm Holley 2bbl to:**

- Holden 253 V8 fitted with 2bbl carb
- Valiant Hemi 6cyl With 2bbl carb
- Valiant V8, Jeep, Chevy V8 with 2bbl carb
- Leyland P76, Dodge 6cyl & V8 with 2bbl carb

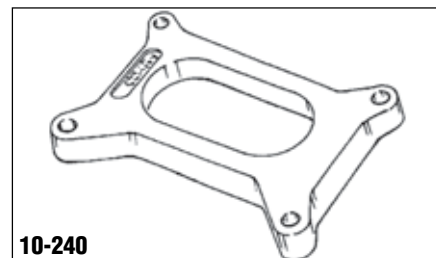

**10-240**

**Universal 2bbl spacer**

12mm (1/2") thick  
Fits Holley 350cfm, 320cfm & Autolite carbs.  
Note: This spacer can also be used as an adaptor & drilled for special applications.

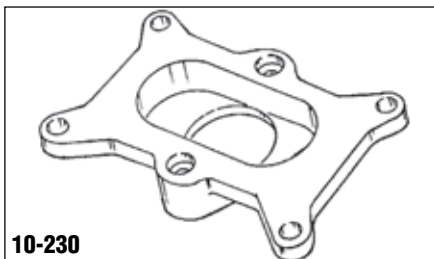

**10-230**

**Adapts 350cfm Holley 2bbl downdraught carburettor to:**

- 6cyl Ford Falcon XC, XD, & Cortina 6cyl with X-flow cast iron or alloy heads 1976-1980 models
- Note: Will only fit models with 1bbl carb alloy head.

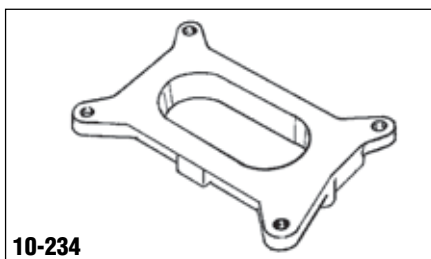

**10-234**

**Blank carburettor adaptor**

Adapts 350cfm Holley 2bbl carburettor to most 2bbl manifolds. Requires drilling to most manifolds

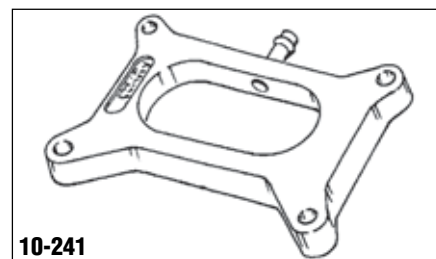

**10-241**

**Universal 2bbl spacer with PCV spout**

12mm (1/2") thick  
Fits Holley 350cfm, 320cfm & Autolite carbs.  
Note: This spacer can also be used as an adaptor & drilled for special applications.

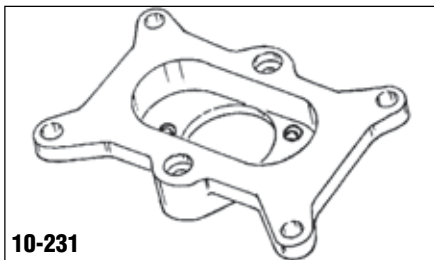

**10-231**

**Adapts Holley 350cfm 2bbl carb to:**

- Ford Falcon 6cyl 1960-1975 models

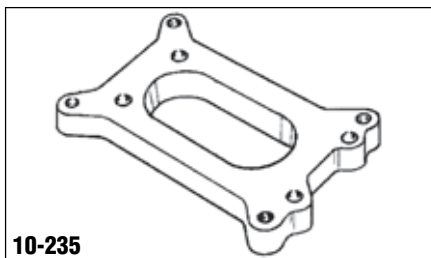

**10-235**

**Adapts Holley 350cfm 2bbl carb to:**

- Toyota Landcruiser with 3F engine late 1984 to early 1990 (black rocker cover)

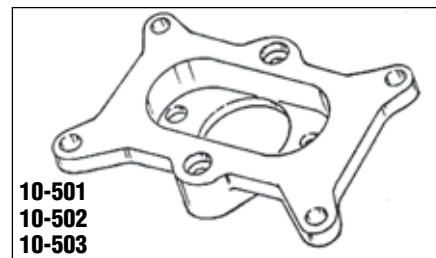

**10-501  
10-502  
10-503**

**Adapts 320/350cfm Holley to:**

- 10-501** • Holden 149-186 (1964-1973)
- 10-502** • Holden 202 with 3/8" studs & Nissan Patrol 4WD with 1bbl carb manifold
- 10-503** • Holden 202 with 5/16" studs

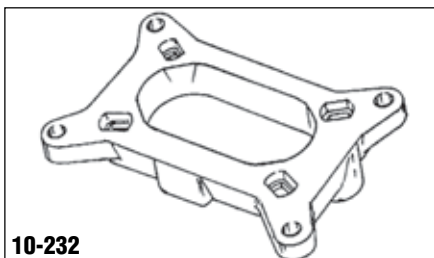

**10-232**

**Adapts Holley 350cfm 2bbl carb to:**

- Toyota Landcruiser with 2bbl carb 1970 to early 1984 models 2F engine (silver rocker cover)

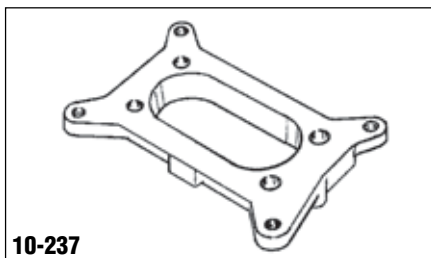

**10-237**

**Adapts Holley 350cfm 2bbl carb to:**

- Most 2bbl Downdraught Weber manifolds or 2bbl Weber Carburettor to 350cfm 2bbl manifolds

Note: Will not suit X-flow 6cyl Falcon.

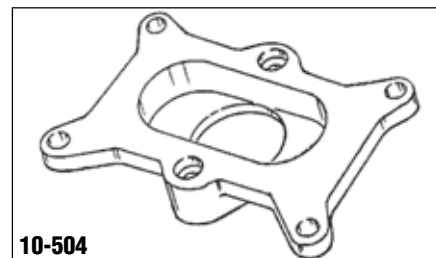

**10-504**

**Blank adaptor**

Suits 320/350cfm Holley to single barrel manifold.  
Can be drilled to suit.

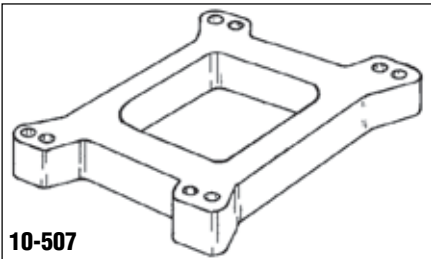

**10-507**

**Competition spacer**  
25mm (1") high  
4bbl square pattern type.

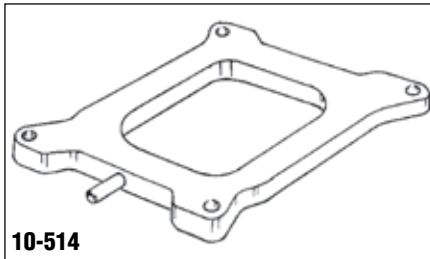

**10-514**

**4bbl square pattern universal spacer with PCV spout**  
12mm (1/2") thick  
This spacer is designed to fit between the carburettor base and the manifold so a PCV line can be used and also when a 4bbl carburettor is not fitted with a PCV take off. Spacer can be ordered without spout (part no. 10-521)

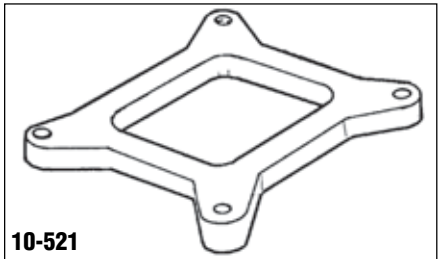

**10-521**

**Universal spacer**  
12mm (1/2") thick  
4bbl square pattern type.

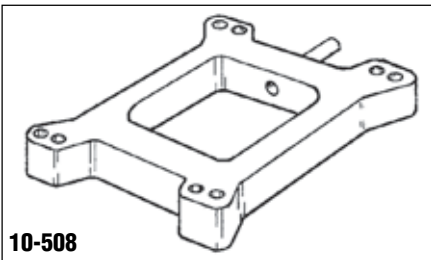

**10-508**

**Competition spacer**  
25mm (1") high  
4bbl with PCV spout, square pattern type.

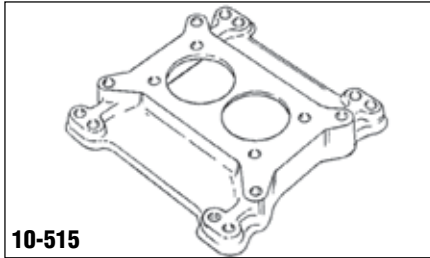

**10-515**

**Universal adaptor, 4bbl to 2bbl, or 2bbl to 4bbl**  
Adapts 4bbl spreadbore (450cfm) or 4bbl square pattern carbs to 2bbl Holley or Autolite manifold or WW Stromberg manifold. Adaptor is reversible. WW Stromberg or 2bbl Holley to 4bbl spreadbore or square pattern manifold.

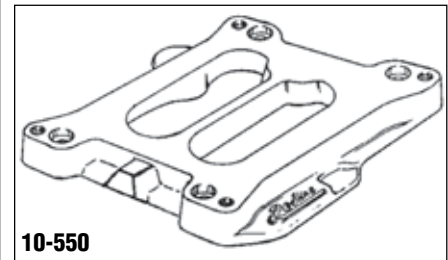

**10-550**

**Adapts 4bbl squarebore carburettors to:**  
• Ford XC, XD, XE 302-351ci Cleveland V8  
This adaptor has no PCV spout.

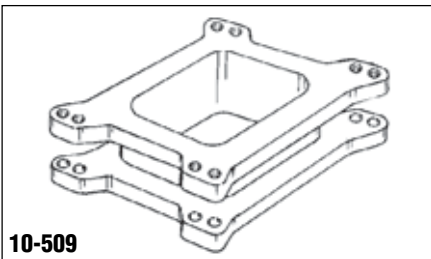

**10-509**

**Competition spacer**  
51mm (2") high  
4bbl square pattern type.

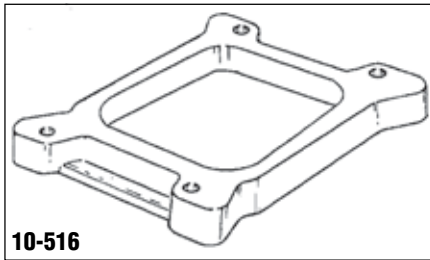

**10-516**

**Competition spacer**  
25mm (1") thick  
4bbl spreadbore type.

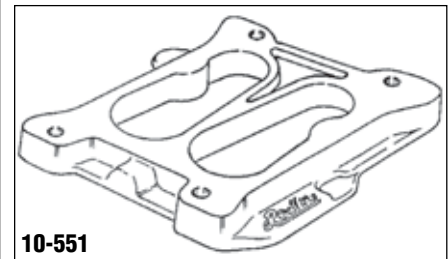

**10-551**

**Adapts 4bbl spreadbore carburettors to:**  
• Ford XC, XD, XE 302-351ci Cleveland V8

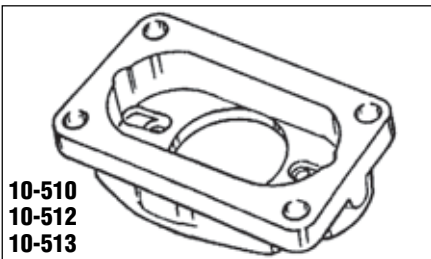

**10-510**  
**10-512**  
**10-513**

**Adapts Holley 1-238, 1-239 or 32/36DGV Weber downdraught to:**  
**10-510** • Holden 149-186  
**10-512** • Holden 202 with 3/8" studs  
**10-513** • Holden 202 with 5/16" studs

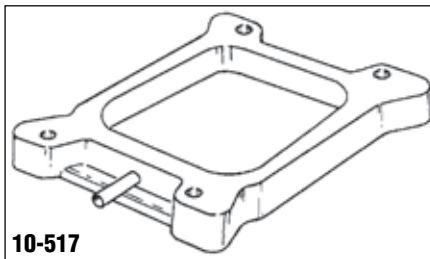

**10-517**

**Competition spacer with spout**  
25mm (1") thick  
4bbl spreadbore type.

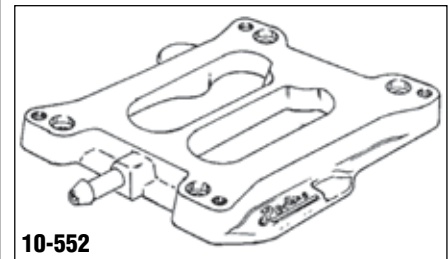

**10-552**

**Adapts 4bbl squarebore carburettors to:**  
• Ford XC, XD, XE 302-351ci Cleveland V8  
This adaptor has a PCV spout.

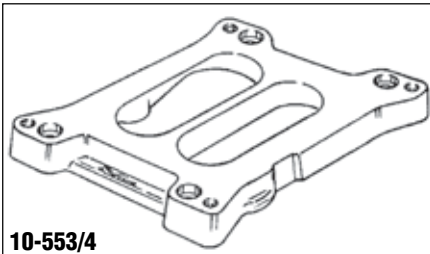

**10-553/4**

**Adapts 4bbl squarebore carburettors to:**

- Holden 308 V8 & Chevy 307-327-350 engines

**Or spreadbore pattern carburettors to:**

- Ford 289-302 Windsor & 351 Cleveland with a square pattern manifold

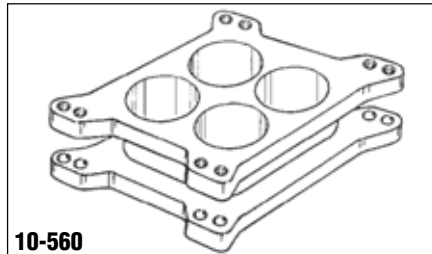

**10-560**

**Competition spacer**  
4bbl square pattern with 4 separate holes.  
Adaptor is 50mm (2") high.

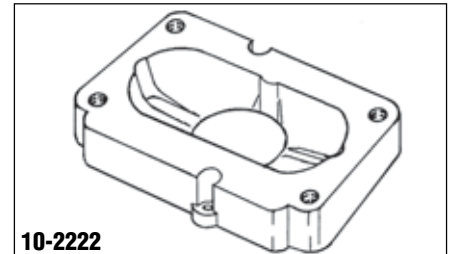

**10-2222**

**Adapts Weber 32/36DGV 2bbl downdraught carburettor to:**

- Ford Falcon 6cyl 1960-1975 & Cortina 6cyl TC, TD

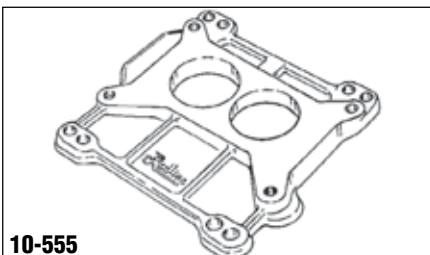

**10-555**

**Adapts 2bbl 320cfm, 350cfm, 500cfm Holley carburettors to:**

- Ford XC, XD, XE 302-351ci Cleveland V8 with Carter Thermo-Quad carburettor

Also fits Holden 308 V8 Rochester Quadrajet manifold.  
Will also fit 4bbl square pattern manifold.

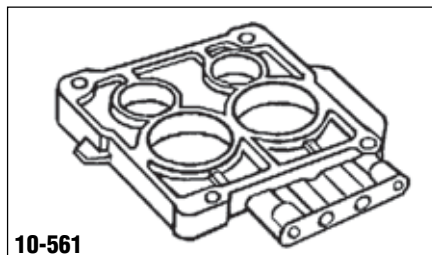

**10-561**

**EGR adaptor plate to suit:**

- Ford Falcon V8 XC-XE.

Fits under carburettor and on top of intake manifold.

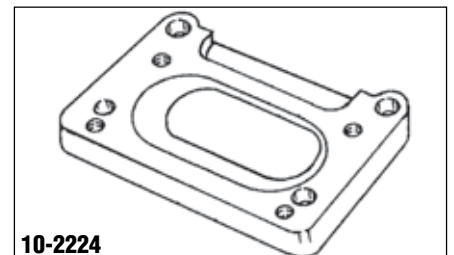

**10-2224**

**Adapts Weber 32/36DGV 2bbl downdraught carburettor to:**

- Toyota 22R and RA65 Celica, Corona, Celica 2000, RA60, 21RC Bunderra, Hi-Lux 18R 1981-1985 with stud centres 97mm x 54mm

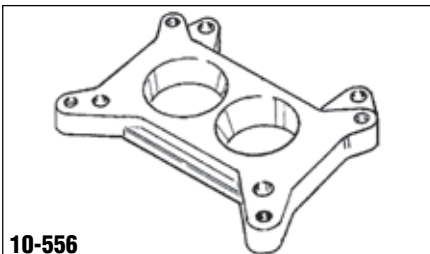

**10-556**

**Carburettor adaptor**  
Adapts 350cfm Holley carburettor to 200/229ci GM V6 engine.

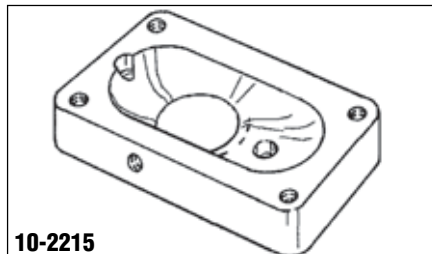

**10-2215**

**Adapts Weber 32/36DGV 2bbl downdraught carburettor to:**

- Ford Falcon 6cyl XC, XD X-flow cast iron or alloy head
- Also Cortina 6cyl 1976-1980.

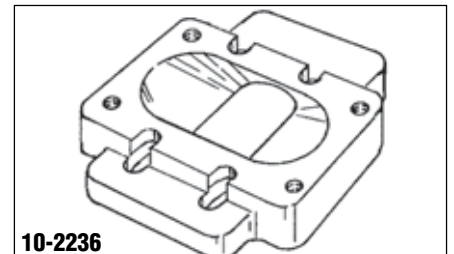

**10-2236**

**Adapts Weber 32/36DGV 2bbl downdraught carburettor to:**

- Honda Civic, Accord, Nissan Pulsar, Prairie FWD
- Holden Astra 1488cc 1984-on

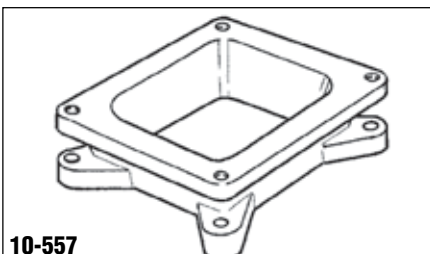

**10-557**

**Carburettor adaptor**  
Adapts Holley 4bbl Dominator carburettor to square pattern 4bbl manifold.  
Adaptor is 54mm (2 1/8") high.

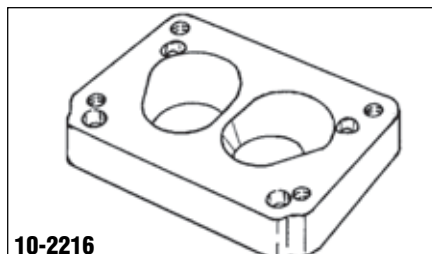

**10-2216**

**Adapts Weber 38DGM 2bbl downdraught carburettor to:**

- Chrysler Valiant 6cyl & V8 fitted with 2bbl Carter carburettor

Also fits 6cyl Centura. Also Holden 186 & GTR Torana with 2bbl Stromberg carb & 253V8.

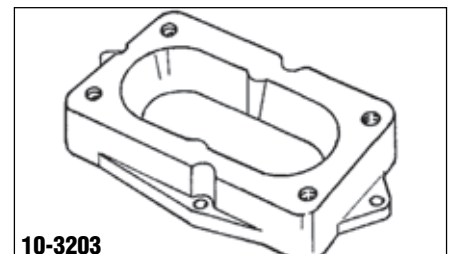

**10-3203**

**Adapts Weber 32/36DGV 2bbl downdraught carburettor to:**

- VW Golf fully imported model with 2bbl carburettor





**10-558**  
**10° Marine Carburettor Wedge Adaptor**  
 To suit squarebore Holley carburettors



**10-9136**  
**Phenolic Competition Spacer**  
 25mm (1in) thick. 4bbl squarebore Open type



**10-9137**  
**Phenolic Competition Spacer**  
 50mm (2in) thick. 4bbl squarebore Open type



**10-559**  
**10° Marine Carburettor Wedge Adaptor**  
 To suit spreadbore Holley carburettors



**10-9134**  
**Phenolic Competition Spacer**  
 25mm (1in) thick. 4bbl squarebore Ported type

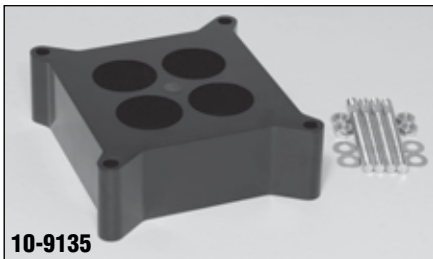

**10-9135**  
**Phenolic Competition Spacer**  
 50mm (2in) thick. 4bbl squarebore Ported type



*Photo by Jon Van Daal*

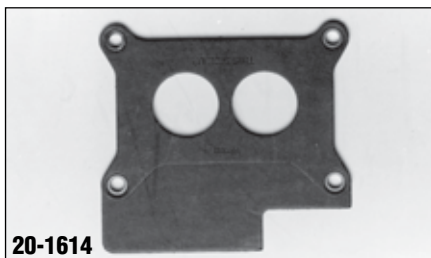

*Photo by Jon Van Daal*



**10-112HK**

**Hardware kit**  
to suit 10-112 Redline adaptor



**20-1614**

**2bbl fibre heat insulator**  
(fits under carburettor base)  
suits 2bbl Holley carburetors

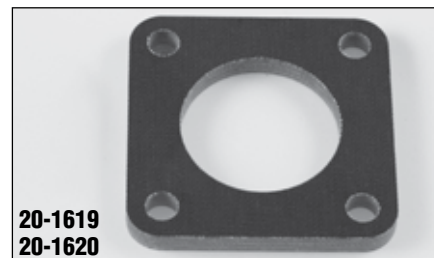

**20-1619  
20-1620**

**Heat Insulator**  
20-1619 suits SU Carburetors 1.75 x 1/4"  
20-1620 suits SU Carburetors 1.75 x 1/2"



**10-232HK**

**Hardware kit**  
to suit 10-232 Redline adaptor

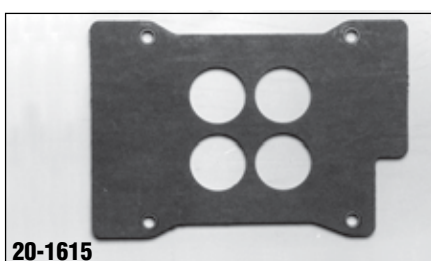

**20-1615**

**4bbl fibre heat insulator**  
(fits under carburettor base)  
suits 4bbl Holley squarebore carburetors



**10-233HK**

**Hardware kit**  
to suit 10-233, 10-515,  
10-553/4 Redline adaptor

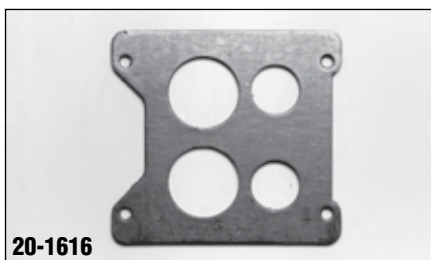

**20-1616**

**4bbl fibre heat insulator**  
(fits under carburettor base)  
suits 4bbl Holley spreadbore carburetors



**10-550HK**

**Hardware kit**  
to suit 10-550, 10-552,  
10-555 Redline adaptor

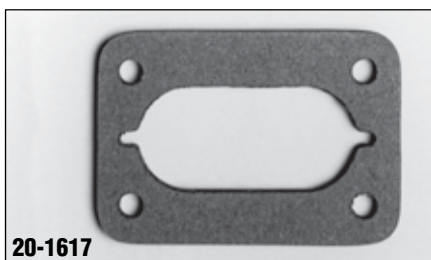

**20-1617**

**2bbl fibre heat insulator**  
(fits under carburettor base)  
suits 2bbl WW Stromberg carburetors

<b>Part No.</b>	<b>Inlet Manifolds to suit 4 cylinder engines</b>	<b>Carburettor or TBI</b>
12-3005	BLMC Mini 850-1275cc	1 x DCOE Weber
12-3047	BLMC Mini 850-1275cc & Austin Healey Sprite Competition manifold	1 x DCOE Weber
12-24	BLMC Mini 850-1275 & Austin Healey Sprite	2 x 1 1/4" SU
12-3009	BLMC MGB and MGB-GT	1 X DCOE Weber
12-3093	BMW 1600, 1800, 2000, 2002	2 X DCOE Webers
12-3019	Ford Anglia, Cortina 1000, 1200, 1500cc 1962-66	2 x DCOE Webers
12-3048	Ford Cortina 1600cc X-Flow engine 1967-1970	2 x DCOE Webers
12-3132	Ford Cortina, Escort 2 Litre	1 x DCOE Weber
12-3118	Ford Cortina, Escort 2 Litre	2 x DCOE Webers
12-3207	Holden Gemini, Jackaroo 1600-2000cc Isuzu engine	2 x IDF Webers
12-3095	Lotus Europa Engine	1 x DCOE Weber
12-3146	Mazda 12A Rotary Twin Distributor Models	1 x 48 IDA Weber
12-3147	Mazda 12A Rotary (not 6 port models)	1 x 48 IDA Weber
12-3149	Mazda 13B Rotary (not 6 port models)	1 x 48 IDA Weber
12-3206	Mitsubishi Sigma, Galant, Scorpion, Colt Starion, Pajero, Triton ute, 1850-2600cc Astron engine MKI, MKII, & III	2 x DCOE Webers
12-3124	Mitsubishi Colt, Galant, Lancer 1300-1600cc (4G30, 4G31, 4G32, 4G33 engines) Saturn Engine OHC Chain drive only. Will not fit belt driven engines.	1 x DCOE Weber
12-3060	Nissan Datsun 1000, 1200 120Y 140 (A10, A12, A12A)	2 x DCOE Webers
12-3114	Nissan Datsun 1000, 1200, 120Y 140 (A10, A12, A12A)	1 x DCOE Weber
12-3115	Nissan Datsun 1600, 1800, 180B, 180BSSS, 200B Bluebird (L16, L18, L20 series 610, 710, 810, 910)	1 x DCOE Weber
12-3063	Nissan Datsun 1600, 1800, 180B, 180BSSS, 200B Bluebird (L16, L18, L20 series 610, 710, 810, 910)	2 x DCOE Webers
12-18	Nissan Datsun 1400, 1500, A14, A15 Sunny & Pulsar series B210.	2 x DCOE Webers
12-3040	Sunbeam Alpine Engine	2 x DCOE Webers
12-3112	Toyota Corolla, Corona Starlet 1100, 1200, 1300, 1500 3K, 4K, 5K engines. Exhaust Headers Must Be Fitted	1 x DCOE Weber
12-3062	Toyota Corolla, Corona Starlet 1100, 1200, 1300, 1500 3K, 4K, 5K engines. Exhaust Headers Must Be Fitted	2 x DCOE Webers
12-3135	Toyota 1600 (2T engine) TA22, TA23	1 x DCOE Weber
12-3136	Toyota 1600 (2T engine) TA22, TA23	2 x DCOE Webers
12-3133	Toyota 2000 8R, 18R (Australian engine only)	1 x DCOE Weber
12-3142	Toyota 2000 8R, 18R (Australian engine only)	2 x 40 DCN Webers
12-19	Toyota 1600cc Twin Cam 2TG engine	2 x DCOE Webers
12-20	Toyota 2000cc Twin Cam Engine 18RG, 18R-GU, 18R-GEU	2 x DCOE Webers
12-22	Toyota 1600cc Twin Cam 4AGE Engine Single Port 100KW	2 x DCOE Webers
12-23	Toyota 1600cc Twin Cam 4AGE Engine Large Twin Port (TV15) 89KW	2 x DCOE Webers
12-3044	Volvo 1960-68 122, 144, P180, B18 & B20	2 x DCOE Webers

<b>Part No.</b>	<b>Inlet Manifolds to suit 6 cylinder engines</b>	<b>Carburettor or TBI</b>
12-61	Holden 6 cyl 1964-on Red Engines	3 x 1BBL Strombergs
12-65m	Holden 1964-on Red, Blue & Black cylinder heads, manifold supplied with heat transfer arms	Holley 320 or 350CFM 2BBL
12-66	Holden 6 cyl 1964-on Red engines	2 x 1BBL Strombergs
12-67	Holden 6 cyl 1964-on Red or Blue engine	1 x 465CFM Holley 4BBL
12-68	Holden 6 cyl 1964-on Red or Blue engine	3 x 1 3/4" SUs
12-3130	Holden 6 cyl 1964-80 Red engines	3 x 45 DCOE Webers
12-3131	Holden 6 cyl 1981 on Blue or Black engines	3 x 45 DCOE Webers
12-3038	Jaguar E Type 3.8, 4.2 Litre 6 cyl engine	3 x 45 DCOE Webers
12-3126	Nissan Datsun 6 cyl 240Z, 260Z and 280Z	3 x 45 DCOE Webers
12-3013	Austin Healey 3000 6 cyl Sports Car	3 x 45 DCOE Webers
12-44	Chrysler Valiant & Centura 6 cyl Hemi engines 245-265 ci	1 x Holley 465CFM 4BBL
12-45	Chrysler Valiant & Centura 6 cyl Hemi engine 245-265 ci	3 x 45 DCOE Webers
12-48	Chrysler Valiant and Centura 6 cyl Hemi engine	3 x 1 3/4" SUs
12-52	Chrysler Valiant Slant 6 engine	3 x DCOE Webers
12-53	Chrysler Valiant Slant 6 engine	3 x 1 3/4" SUs
12-54	Chrysler Valiant Slant 6 engine	1 x 465CFM 4BBL
12-43	Ford 6 cyl Cast Iron X-Flow Head 1976-79	Holley 350CFM 2BBL
12-46	Ford 6 cyl Cast Iron X-Flow Head 1976-79	Holley 450CFM 4BBL



<b>Part No.</b>	<b>Inlet Manifolds to suit 6 cylinder engines</b>	<b>Carburettor or TBI</b>
12-47	Ford 6 cyl Cast Iron X-Flow Head 1976-79	3 x 45DCOE Webers
12-70	Ford 6 cyl X-Flow Alloy Head 1980-on	Holley 350CFM 2BBL
12-71	Ford 6 cyl X-Flow Alloy Head 1980-on	Holley 465CFM 4BBL
12-72	Ford 6 cyl X-Flow Alloy Head 1980-on	3 x 45 DCOE Webers
<b>Part No.</b>	<b>Inlet Manifolds to suit V8 engines</b>	<b>Carburettor or TBI</b>
12-114	Holden Torker Single Plane manifold to suit 253-308 Red, Blue or Black Heads. (Not VN on)	4BBL Spread Bore or Square Bore
12-116	Holden Hi-Winder Single Plane manifold to suit 253-308 V8 fitted with VN cylinder heads. Manifold has 8 bosses which can be drilled to fit Fuel Injection	4BBL Spread Bore or Square Bore
12-126	Tunnel Ram manifold suit Holden 253-308 with VN Heads	2 x 4BBL Square Bore
12-118	Blower manifold suit Holden 253-308 with (not VN on)	B&M or Weiand low profile blowers
KC308M	Dual Plane Pollution application, Kilkenny casting manifold to suit Holden 253-308 Red, Blue, Black heads Not VN on	4BBL Spread Bore or Square Bore
12-308/12-100	Quad Weber Downdraft Manifold suit Holden 253-308 V8 Red, Blue or Black Engines (not VN on)	4 x 44 or 48 IDF Webers
12-308/12-105	Quad Weber Downdraft Manifold to suit Holden 253-308 V8 Red, Blue or Black engines (not VN on)	4 x 48 IDA Webers
12-309	Quad Weber Downdraft manifold to suit Holden 253-308 V8 fitted with VN Commodore Heads	4 x 44 or 48 IDF Webers
12-120/12-200	Tunnel Ram manifold to suit Holden 308 V8 Red, Blue, Black engines	2 x 4BBL Square Bore
12-123	Quad Weber manifold to suit Chevy 283-400 c.i. engines	4 x IDF Webers
12-121	Single Plane Torker Manifold to suit Chevy 283-400 c.i.	1 x 4BBL Spread Bore or Square Bore
12-125/12-200	Tunnel Ram manifold suit Chevy 283-400 c.i. engine	2 x 4BBL Square Bore
12-154	Single Plane Torker style manifold suit Ford 302-351C with 2V or 4V cylinder heads. Port size is 2V.	4BBL Spread Bore or Square Bore carb
12-155	Dual plane Performer Manifold suit Ford 289-302W	1 x 4BBL Square Bore
12-159/12-200	Tunnel Ram manifold suit Ford 351C	2 x 4BBL Square Bore
12-351/12-101	Quad Weber Downdraft manifold suit Ford 302-351C with 2V or 4V cylinder heads	4 x 44 or 48 IDF Webers
12-351/12-106	Quad Weber Manifold suit Ford 302-251 C	4 x 48 IDA Webers
12-302	Quad Weber Downdraft manifold suit Ford 289-302 Windsor	4 x 44 or 48 IDF Webers
12-3143	Adaptor to fit Twin Downdraft Webers to Holden V8 253-308, Ford 302-351C & 289-302W V8 manifolds	2 x 44 or 48 IDF Webers
12-3144	Adaptor to fit Twin Sidedraft Webers to Holden V8 253-308, Ford 302-351C & Ford 289-302W 4 BBL manifolds	2 x 45 or 48 DCOE Webers

*Manifolds and adaptors are inspected after casting in the foundry. Parts are then machined, hot tanked, deburred and inspected again before packaging.*



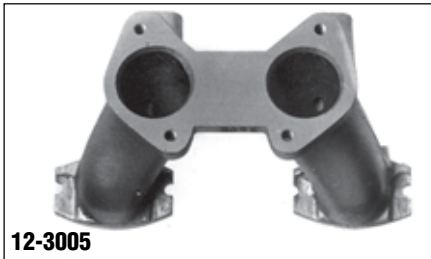

**12-3005**

BLMC Mini 850-1275cc

Carburettor or TBI	Linkage Kit	Air Filter
1 x DCOE Weber	42-2505	16-43 or 16-45

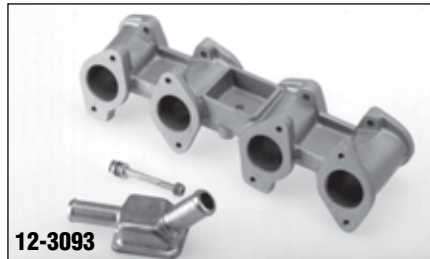

**12-3093**

BMW 1600, 1800, 2000, 2002

Carburettor or TBI	Linkage Kit	Air Filter
2 x DCOE Webers	42-2500	16-43 or 16-45

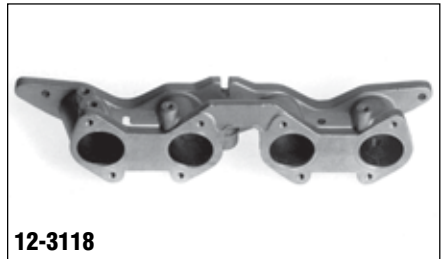

**12-3118**

Ford Cortina, Escort 2 Litre

Carburettor or TBI	Linkage Kit	Air Filter
2 x DCOE Webers	42-2618	16-43 or 16-45

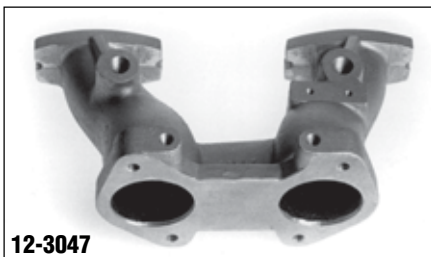

**12-3047**

BLMC Mini 850-1275cc & Austin Healy Sprite Competition Manifold

Carburettor or TBI	Linkage Kit	Air Filter
1 x DCOE Weber	42-2505	16-43 or 16-45



**12-3019**

Ford Anglia, Cortina 1000, 1200, 1500cc 1962-1966

Carburettor or TBI	Linkage Kit	Air Filter
2 x DCOE Webers	42-2519	16-43 or 16-45

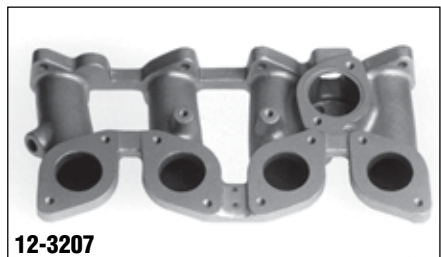

**12-3207**

Holden Gemini, Jackaroo 1600-2000cc Isuzu Engine

Carburettor or TBI	Linkage Kit	Air Filter
2 x IDF Webers	42-2707	16-44

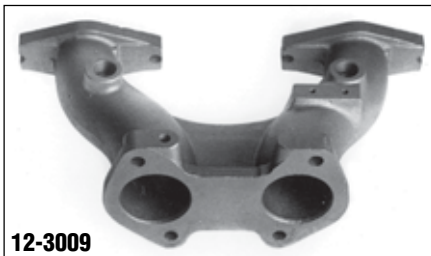

**12-3009**

BLMC MGB & MGB-GT

Carburettor or TBI	Linkage Kit	Air Filter
1 x DCOE Weber	42-2509	16-43 or 16-45

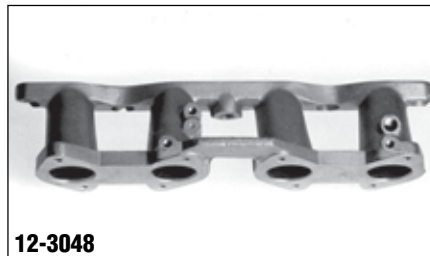

**12-3048**

Ford Cortina 1600cc X-Flow Engine 1967-1970

Carburettor or TBI	Linkage Kit	Air Filter
2 x DCOE Webers	42-2548	16-43 or 16-45



**12-3146**

Mazda 12A Rotary Twin Distributor Models

Carburettor or TBI	Linkage Kit	Air Filter
1 x 48IDA Weber	N/A	N/A



**12-24**

BLMC Mini 850-1275 & Austin Healy Sprite

Carburettor or TBI	Linkage Kit	Air Filter
2 x 1 1/4" SU Carb		16-1

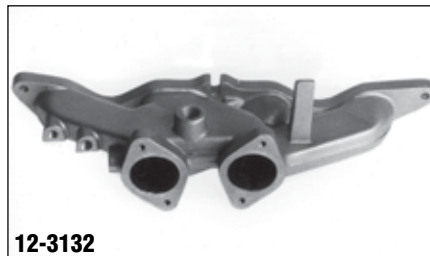

**12-3132**

Ford Cortina, Escort 2 Litre

Carburettor or TBI	Linkage Kit	Air Filter
1 x DCOE Weber	42-2632	16-43 or 16-45



**12-3147**

Mazda 12A Rotary (not 6 port models)

Carburettor or TBI	Linkage Kit	Air Filter
1 x 48IDA Weber	N/A	N/A

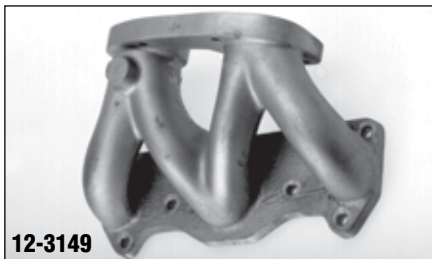
**12-3149**

Mazda 13B Rotary (not 6 port models)

Carburettor or TBI	Linkage Kit	Air Filter
1 x 48IDA Weber	N/A	N/A

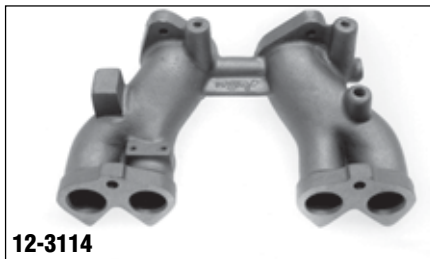
**12-3114**

Nissan Datsun 1000, 1200 120Y 140 (A10, A12, A12A)

Carburettor or TBI	Linkage Kit	Air Filter
1 x DCOE Weber	42-2614	16-43 or 16-45

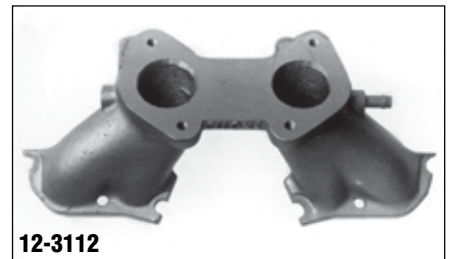
**12-3112**

Toyota Corolla, Corona Starlet 1100, 1200, 1300, 1500 3K, 4K, 5K Engines  
 Note: Exhaust Headers must be fitted

Carburettor or TBI	Linkage Kit	Air Filter
1 x DCOE Weber	42-2612	16-43 or 16-45

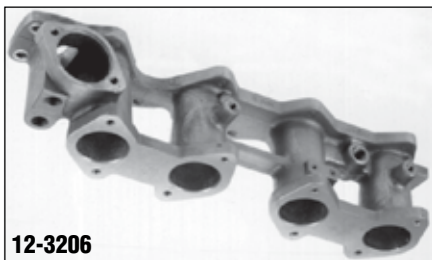
**12-3206**

Mitsubishi Sigma, Galant, Scorpion, Colt Starion, Pajero, Triton ute, 1850-2600cc Astron Engine MKI, MKII, MKIII

Carburettor or TBI	Linkage Kit	Air Filter
2 x DCOE Webers	42-2706	16-43 or 16-45

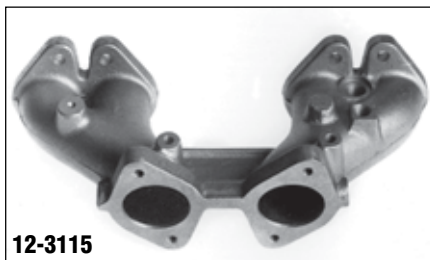
**12-3115**

Nissan Datsun 1600, 1800, 180B, 180BSSS, 200B Bluebird (L16, L18, L20 series 610, 710, 810, 910)

Carburettor or TBI	Linkage Kit	Air Filter
1 x DCOE Weber	42-2615	16-43 or 16-45

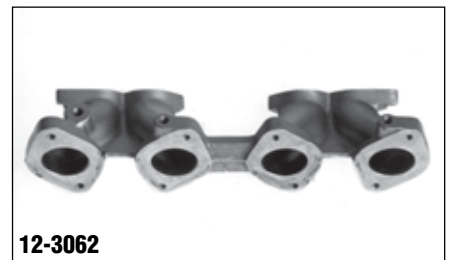
**12-3062**

Toyota Corolla, Corona Starlet 1100, 1200, 1300, 1500 3K, 4K, 5K Engines  
 Note: Exhaust Headers must be fitted

Carburettor or TBI	Linkage Kit	Air Filter
2 x DCOE Webers	42-2562	16-43 or 16-45

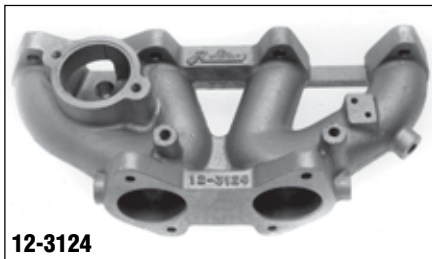
**12-3124**

Mitsubishi Colt, Galant, Lancer 1300-1600cc (4G30, 4G31, 4G32, 4G33 Engines)  
 Saturn Engine OHC chain drive only.  
 Will not fit belt driven engines

Carburettor or TBI	Linkage Kit	Air Filter
1 x DCOE Weber	42-2624	16-43 or 16-45

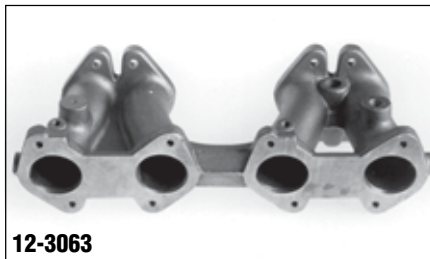
**12-3063**

Nissan Datsun 1600, 1800, 180B, 180BSSS, 200B Bluebird (L16, L18, L20 series 610, 710, 810, 910)

Carburettor or TBI	Linkage Kit	Air Filter
2 x DCOE Webers	42-2561	16-43 or 16-45

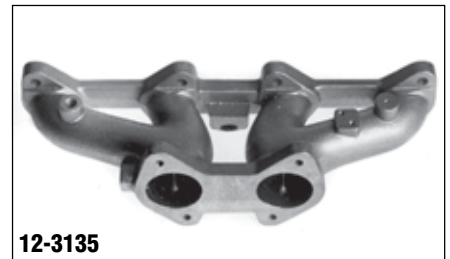
**12-3135**

Toyota 1600 (2T Engine) TA22, TA23

Carburettor or TBI	Linkage Kit	Air Filter
1 x DCOE Weber	42-2635	16-43 or 16-45

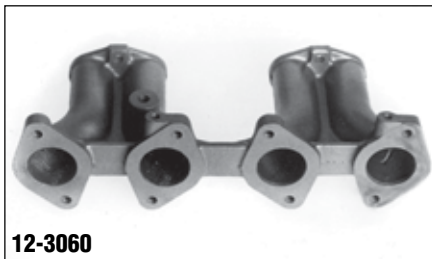
**12-3060**

Nissan Datsun 1000, 1200 120Y 140 (A10, A12, A12A)

Carburettor or TBI	Linkage Kit	Air Filter
2 x DCOE Webers	42-2560	16-43 or 16-45

**12-18**

Nissan Datsun 1400, 1500, A14, A15 Sunny & Pulsar series B210

Carburettor or TBI	Linkage Kit	Air Filter
2 x DCOE Webers	42-29	16-43 or 16-45

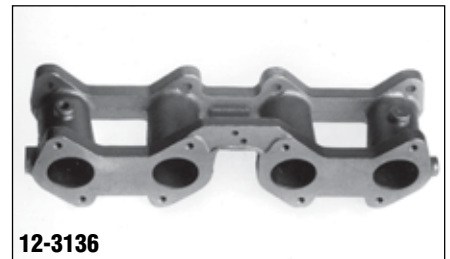
**12-3136**

Toyota 1600 (2T Engine) TA22, TA23

Carburettor or TBI	Linkage Kit	Air Filter
2 x DCOE Webers	42-2636	16-43 or 16-45



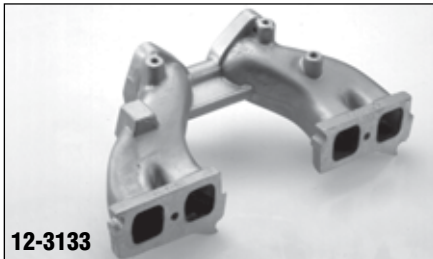

**12-3133**

Toyota 2000 8R, 18R (Aust. Engine only)

Carburettor or TBI	Linkage Kit	Air Filter
1 x DCOE Weber	42-2633	16-43 or 16-45



**12-22**

Toyota 1600cc Twin Cam 4AGE Engine  
Single Port 100KW

Carburettor or TBI	Linkage Kit	Air Filter
2 x DCOE Webers	LP1000	16-43 or 16-45

**Note**

16-43 Air Cleaners suit 40DCOE Webers  
16-45 Air Cleaners suit 45DCOE Webers

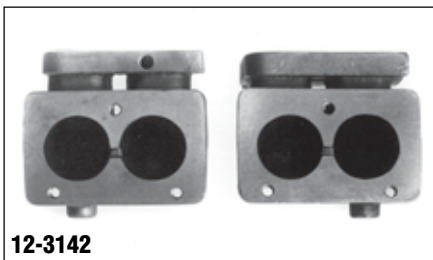

**12-3142**

Toyota 2000 8R, 18R (Aust. Engine only)

Carburettor or TBI	Linkage Kit	Air Filter
2 x 40DCN Webers	42-2642	16-47



**12-23**

Toyota 1600cc Twin Cam 4AGE Engine  
Large Twin Port (TV15) 89KW

Carburettor or TBI	Linkage Kit	Air Filter
2 x DCOE Webers	LP1000	16-43 or 16-45

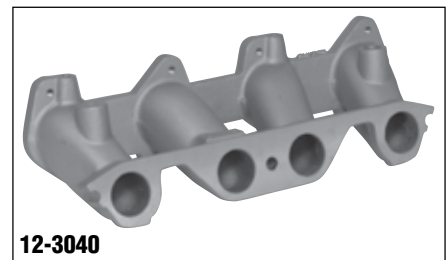

**12-3040**

Sunbeam Alpine

Carburettor or TBI	Linkage Kit	Air Filter
1 x DCOE Weber	42-2655	16-43 or 16-45

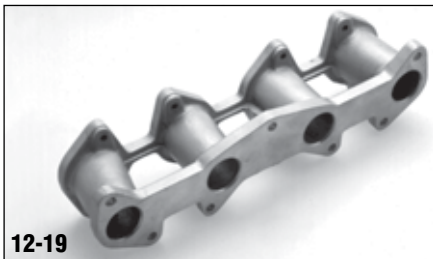

**12-19**

Toyota 1600cc Twin Cam 2TG Engine

Carburettor or TBI	Linkage Kit	Air Filter
2 x DCOE Webers	LP1000	16-43 or 16-45

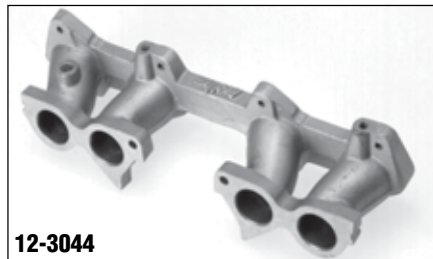

**12-3044**

Volvo 1960-68 122, 144, P180, B18 & B20

Carburettor or TBI	Linkage Kit	Air Filter
2 x DCOE Webers	42-2655	16-43 or 16-45

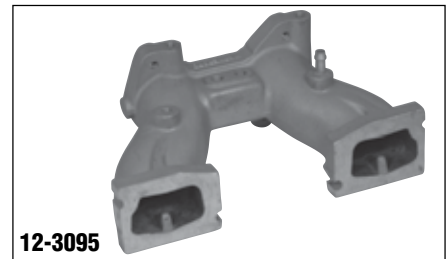

**12-3095**

Louts Europa R16 motor

Carburettor or TBI	Air Filter
1 x DCOE Weber	16-43 or 16-45

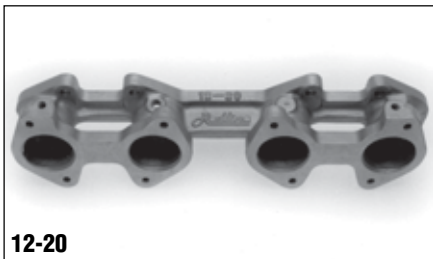

**12-20**

Toyota 2000cc Twin Cam Engine 18RG,  
18R-GU, 18R-GEU

Carburettor or TBI	Linkage Kit	Air Filter
2 x DCOE Webers	LP1000	16-43 or 16-45





**12-3013**

Austin Healy 3000 6cyl Sports Car to fit Sidedraught Webers

Carburettor or TBI	Linkage Kit	Air Filter
3 x 45 DCOE Webers	42-2613	16-45

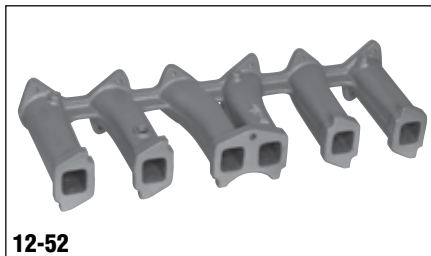

**12-52**

Chrysler/Valiant Slant 6 Engines to suit sidedraft Webers

Carburettor or TBI	Linkage Kit	Air Filter
3 x 45 DCOE Weber	42-28	16-45



**12-43**

Ford 6cyl Cast Iron X-Flow Head 1976-1979 to fit 2 Barrel Holley

Carburettor or TBI	Linkage Kit	Air Filter
Holley 350cfm 2bbl	42-20	16-35

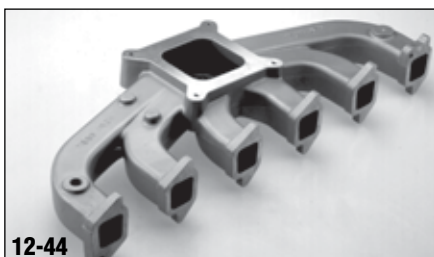

**12-44**

Chrysler Valiant & Centura 6cyl Hemi Engines 245-265ci to fit 4 Barrel Carburettor

Carburettor or TBI	Linkage Kit	Air Filter
Holley 465cfm 4bbl	N/R	16-13

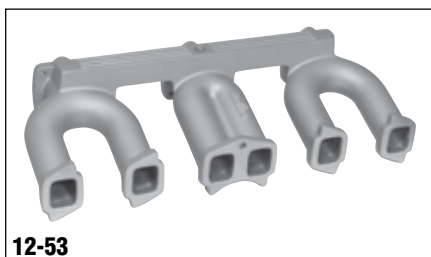

**12-53**

Chrysler/Valiant Slant 6 Engines to suit SU Carburttors

Carburettor or TBI	Linkage Kit	Air Filter
3 x 1 3/4" SU Carb	TBA	16-2

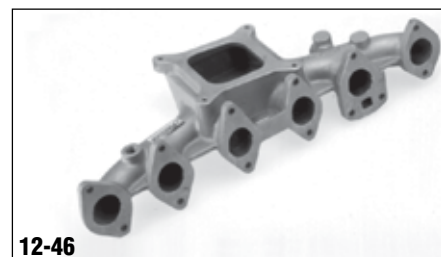

**12-46**

Ford 6cyl Cast Iron X-Flow Head 1976-1979 to fit 4 Barrel Holley carb

Carburettor or TBI	Linkage Kit	Air Filter
Holley 465cfm 4bbl	42-20	16-35



**12-45**

Chrysler Valiant & Centura 6cyl Hemi Engines 245-265ci to fit Sidedraught Weber Carbs

Carburettor or TBI	Linkage Kit	Air Filter
3 x 45 DCOE Webers	42-28	16-45

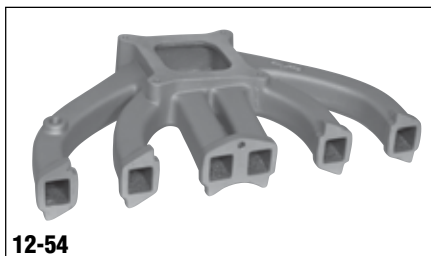

**12-54**

Chrysler/Valiant Slant 6 Engines to suit 4 barrel Carburettor

Carburettor or TBI	Linkage Kit	Air Filter
Holley 390 or 465CFM 4bbl	TBA	16-9



**12-47**

Ford 6cyl Cast Iron X-Flow Head 1976-1979 to fit Sidedraught Webers

Carburettor or TBI	Linkage Kit	Air Filter
3 x 45 DCOE Webers	42-28	16-45



**12-48**

Chrysler Valiant & Centura 6cyl Hemi Engine

Carburettor or TBI	Linkage Kit	Air Filter
3 x 1 3/4" SU Carb	42-48	16-2

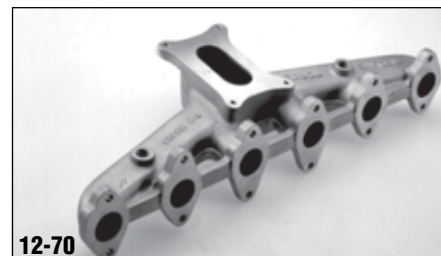

**12-70**

Ford 6cyl X-Flow Alloy Head 1980 on to fit 2 Barrel Holley

Carburettor or TBI	Linkage Kit	Air Filter
Holley 350cfm 2bbl	42-20	16-35



**12-71**

Ford 6cyl X-Flow Alloy Head 1980 on to fit 4 Barrel Holley

Carburettor or TBI	Linkage Kit	Air Filter
Holley 465cfm 4bbl	42-20	16-35



**12-66**

Holden 6cyl 1964 on Red Engines to suit Twin single barrel Stromberg carburettors

Carburettor or TBI	Linkage Kit	Air Filter
2 x 1bbl Strombergs	42-1654	16-4

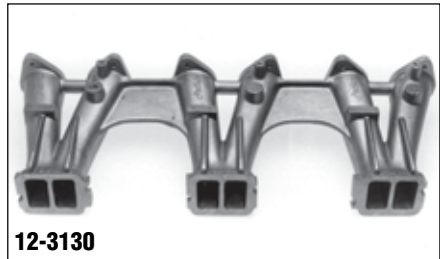

**12-3130**

Holden 6cyl 1964-1980 Red Engines to suit 3 x DCOE Webers

Carburettor or TBI	Linkage Kit	Air Filter
3 x 45 DCOE Webers	42-2630	16-45

Holden LC-UC 6cyl Torana

Carburettor or TBI	Linkage Kit	Air Filter
3 x 45 DCOE Webers	42-37	16-45

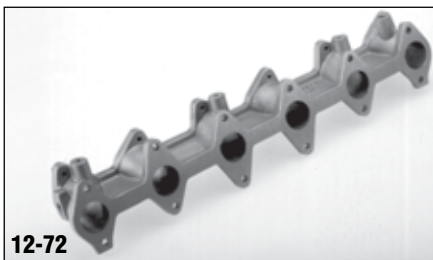

**12-72**

Ford 6cyl X-Flow Alloy Head 1980 on to fit Sidedraught Webers

Carburettor or TBI	Linkage Kit	Air Filter
3 x 45 DCOE Webers	42-28	16-45

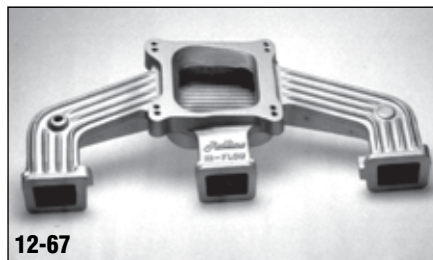

**12-67**

Holden 6cyl 1964 on Red Engine to suit 4 barrel carburettor

Carburettor or TBI	Linkage Kit	Air Filter
1 x 465cfm Holley 4bbl	42-24 HD-HG or 42-22 HQ	16-9

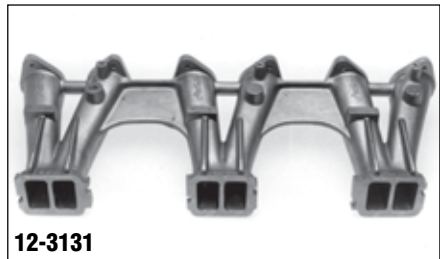

**12-3131**

Holden 6cyl 1981 on Blue or Black Engines to suit 3 x DCOE Webers

Carburettor or TBI	Linkage Kit	Air Filter
3 x 45 DCOE Webers	42-2630	16-45

Holden LC-UC 6cyl Torana

Carburettor or TBI	Linkage Kit	Air Filter
3 x 45 DCOE Webers	42-37	16-45



**12-65M**

Holden 6cyl 1964 on Red, Cylinder Heads to fit Holley 2 Barrel Carb. Manifold supplied with Heat Transfer Arms

Carburettor or TBI	Linkage Kit	Air Filter
Holley 320 or 350cfm 2bbl	42-24 HD-HG or 42-22 HQ 42-36 LC-LJ	16-9

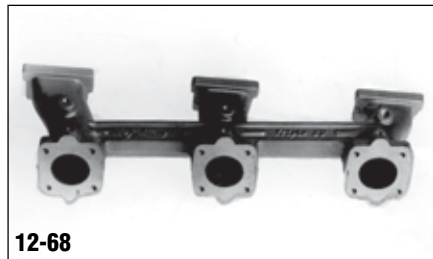

**12-68**

Holden 6cyl 1964 on Red Engine to suit 3 x SU carburettors

Carburettor or TBI	Linkage Kit	Air Filter
3 x 1 3/4" SUs	42-25	16-2

Holden LC-LJ 6cyl Torana

Carburettor or TBI	Linkage Kit	Air Filter
3 x 1 3/4" SUs	42-35	16-2

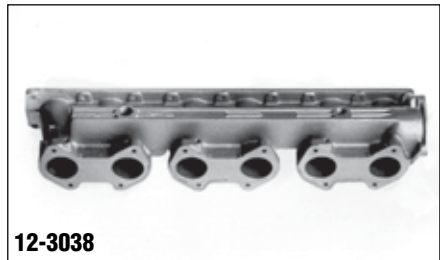

**12-3038**

Jaguar E Type 3.8, 4.2 Litre 6cyl Engine to suit 3 x DCOE Webers

Carburettor or TBI	Linkage Kit	Air Filter
3 x 45DCOE Webers	42-2538	16-45



**12-61**

Holden 6cyl 1964 on Red Engines

Carburettor or TBI	Linkage Kit	Air Filter
3 x 1bbl Strombergs	42-1655	16-4

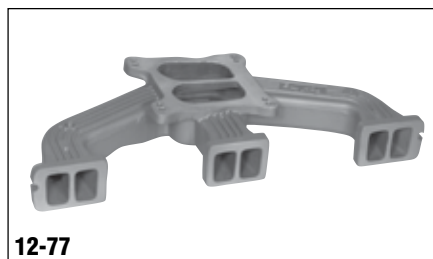

**12-77**

Holden 6cyl 1981 on Blue or Black Engines to suit 4 barrel Carburettor

Carburettor or TBI	Linkage Kit	Air Filter
Holley 390 or 465CFM 4bbl		16-9

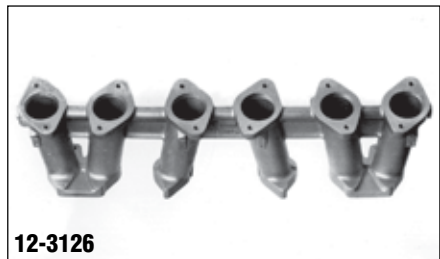

**12-3126**

Nissan Datsun 6cyl 240Z, 260Z & 280Z to suit 3 x DCOE Webers

Carburettor or TBI	Linkage Kit	Air Filter
3 x 45 DCOE Webers	42-2626	16-45



**12-121**

**Chevy Single Plane Torker Manifold**  
to suit 283-400ci Chevy engines

Carburettor or TBI	Linkage Kit	Air Filter
4bbl Spreadbore or Squarebore	N/R	16-13 or 16-14

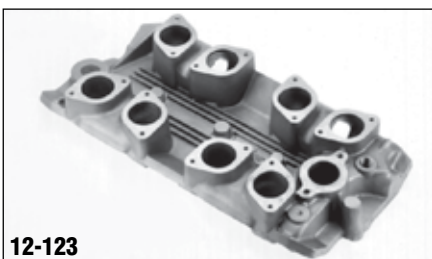
**12-123**

**Chevy Quad IDF Weber or TBI Manifold**  
to suit Chevy V8 283-400ci engines

Carburettor or TBI	Linkage Kit	Air Filter
4 x IDF Webers or TBI	42-38	16-44

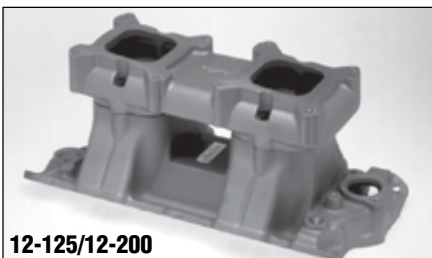
**12-125/12-200**

**Chevy Tunnel Ram Manifold**  
to suit 283-400ci Chevy engines

Carburettor or TBI	Linkage Kit	Air Filter
2 x 4bbl Squarebore Holley or TBI	42-210	16-6

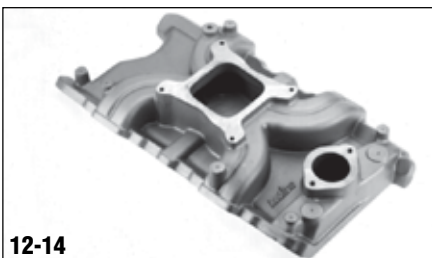
**12-14**

**Chrysler Single Plane Torker Manifold**  
to suit 273-360 Chrysler V8 engines from 1968 on

Carburettor or TBI	Linkage Kit	Air Filter
1 x 4bbl Squarebore Holley	N/R	16-13 or 16-14

**12-154**

**Ford Street Torker Single Plane Manifold**  
to suit 302-351 Cleveland V8 with 2V or 4V Cylinder Heads. Manifold is 2V port size.

Carburettor or TBI	Linkage Kit	Air Filter
4bbl Spreadbore or Squarebore Carb	N/R	16-13 or 16-14

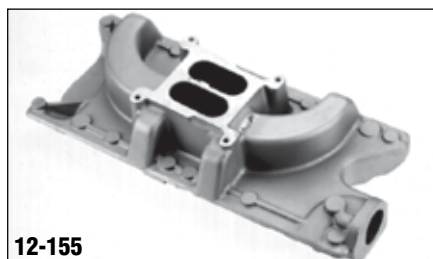
**12-155**

**Ford Dual Plane Street Performer**  
to suit 289-302 Ford Windsor engines

Carburettor or TBI	Linkage Kit	Air Filter
4bbl Squarebore	N/R	16-13 or 16-14

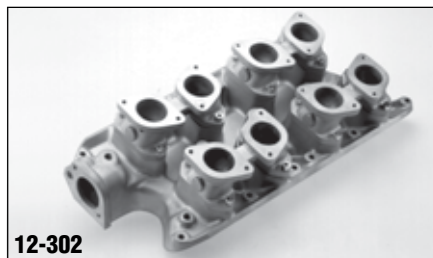
**12-302**

**Ford Quad Weber Downdraught Manifold**  
to suit 289/302 Windsor V8

Carburettor or TBI	Linkage Kit	Air Filter
44-48IDF Weber	42-40	16-44

**12-351/12-101**

**Ford Quad Weber Downdraught Manifold**  
to suit 302-351 Cleveland V8 with 2V or 4V Cylinder Heads

Carburettor or TBI	Linkage Kit	Air Filter
44-48IDF Weber	42-31	16-44

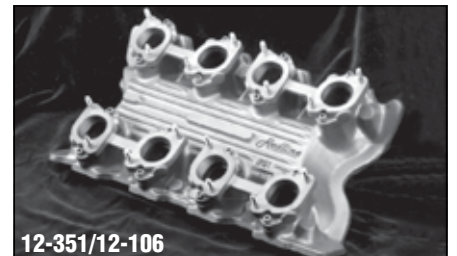
**12-351/12-106**

**Ford Quad Weber Downdraught Manifold**  
to suit 302-351 Cleveland V8 with 2V or 4V Cylinder Heads

Carburettor or TBI	Linkage Kit	Air Filter
48IDA Weber	42-34	N/A

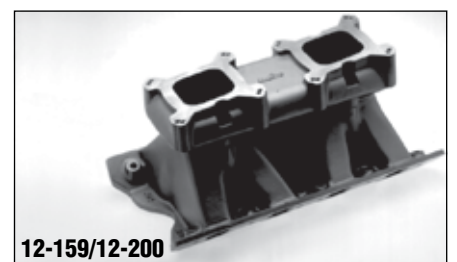
**12-159/12-200**

**Tunnel Ram Manifold**  
to suit Ford 351 Cleveland V8, Fits 2V Head

Carburettor or TBI	Linkage Kit	Air Filter
2 x 4bbl Squarebore or TBI	42-210	16-6

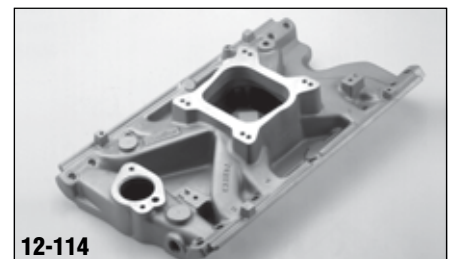
**12-114**

**Holden Torker Single Plane Manifold** to suit 253-308 V8 Holden Red, Blue or Black Heads (not VN on)

Carburettor or TBI	Linkage Kit	Air Filter
4bbl Spreadbore or Squarebore	N/R	16-13 or 16-14

**12-116**

**Holden Hi-Winder Single Plane Manifold**  
to suit 253-308 V8 fitted with VN Cylinder Heads. Manifold has 8 bosses which can be drilled to fit Fuel Injection. This is a low profile performance manifold designed so the bonnet can be closed even with a sports air filter fitted.

Carburettor or TBI	Linkage Kit	Air Filter
4bbl Spreadbore or Squarebore	N/R	16-17

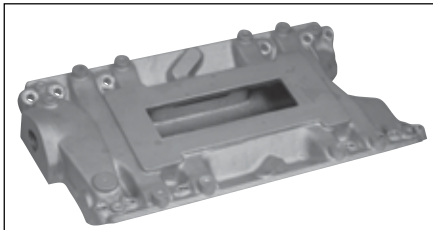

**12-118**

**Holden V8 Blower manifold** to suit 253-308 Red Blue Black Heads (not VN on)  
Accepts B&M and Weiand Low profile blowers

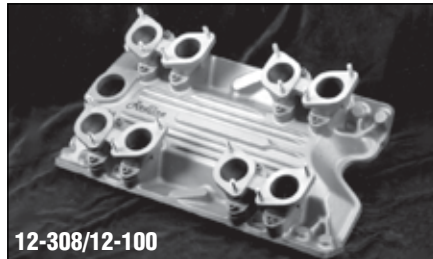

**12-308/12-100**

**Holden Quad Weber Downdraught Manifold** to suit 253-308 V8 Red, Blue or Black Engines (not VN on)

Carburettor or TBI	Linkage Kit	Air Filter
44-48IDF Weber	42-30	16-44

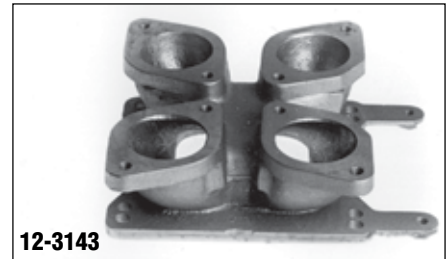

**12-3143**

Adaptor to fit Twin Downdraught Weber Carbs on Holden V8 253-308, Ford Cleveland 302-351 & 289-302 Ford Windsor V8 4 Barrel Manifolds

Carburettor or TBI	Linkage Kit	Air Filter
44-48IDF Weber	42-2143	16-44

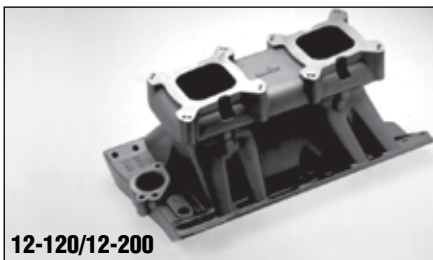

**12-120/12-200**

**Holden V8 Tunnel Ram Manifold** to suit Holden 308 Red, Blue, Black engines

Carburettor or TBI	Linkage Kit	Air Filter
2 x 4bbl Squarebore or TBI	42-210	16-6

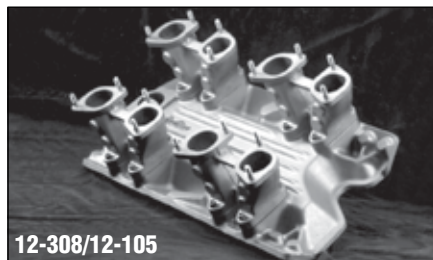

**12-308/12-105**

**Holden Quad Weber Downdraught Manifold** to suit 253-308 V8 Red, Blue or Black Engines (not VN on)

Carburettor or TBI	Linkage Kit	Air Filter
48IDA Weber	42-33	N/A

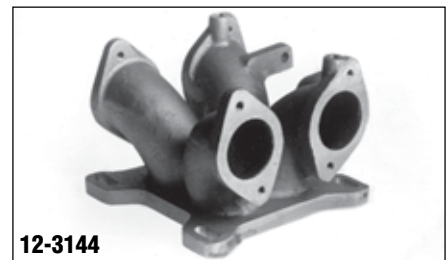

**12-3144**

Adaptor to fit Twin Sidedraught Weber Carbs on Holden V8 253-308, Ford Cleveland 302-351 & 289-302 Ford Windsor V8 4 Barrel Manifolds

Carburettor or TBI	Linkage Kit	Air Filter
45-48DCOE Weber	42-2644	16-45

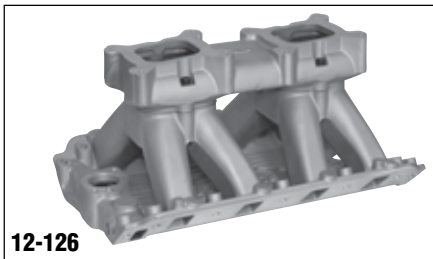

**12-126**

**Holden V8 Tunnel Ram Manifold** to suit VN cylinder heads. Manifold has 8 bosses which can be drilled to fit Fuel Injection.

Carburettor or TBI	Linkage Kit	Air Filter
2 x 4bbl Squarebore or TBI	42-210	16-6



**12-309**

**Holden Quad Weber Downdraught Manifold** to suit 253-308 V8 fitted with VN Commodore Heads

Carburettor or TBI	Linkage Kit	Air Filter
44-48IDF Weber	42-49	16-44

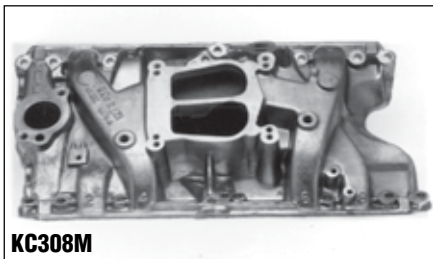

**KC308M**

**Holden Dual Plane Pollution Application Kilkenny casting Manifold** to suit 253-308 V8 Red, Blue or Black Heads (not VN on)

Carburettor or TBI	Linkage Kit	Air Filter
4bbl Spreadbore or Squarebore	N/R	16-13 or 16-14

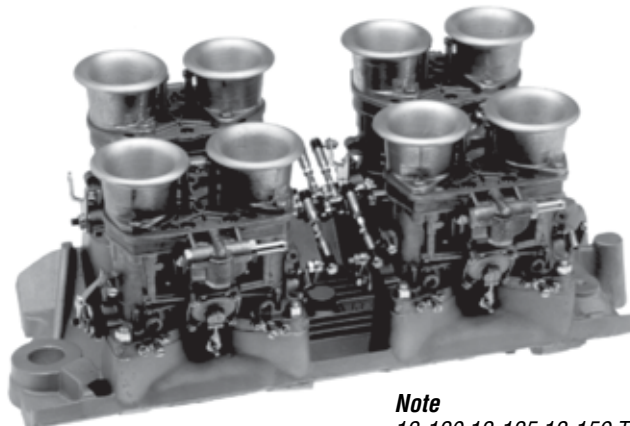

**Note**

12-120, 12-125, 12-159 Tunnel Ram Manifolds will be available with bosses which can be drilled for fuel injectors or nitrous oxide injection.

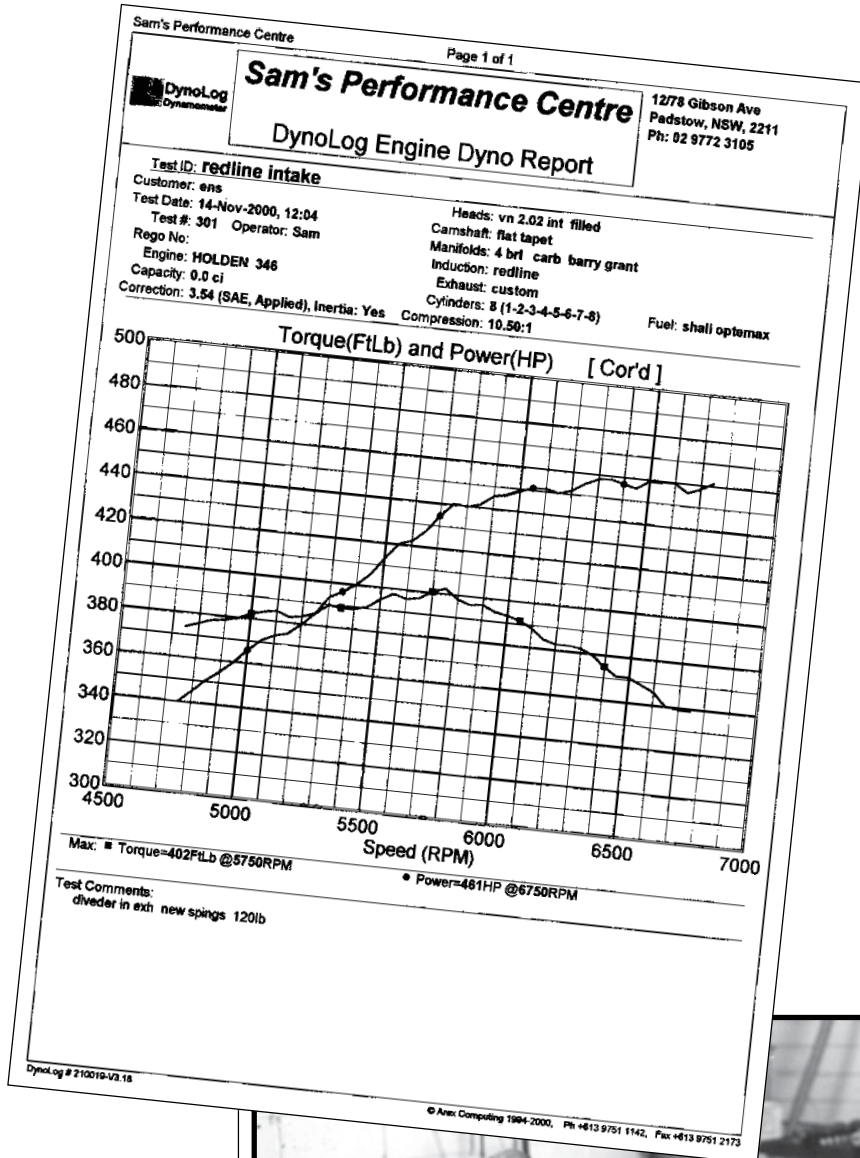

**dyno test**

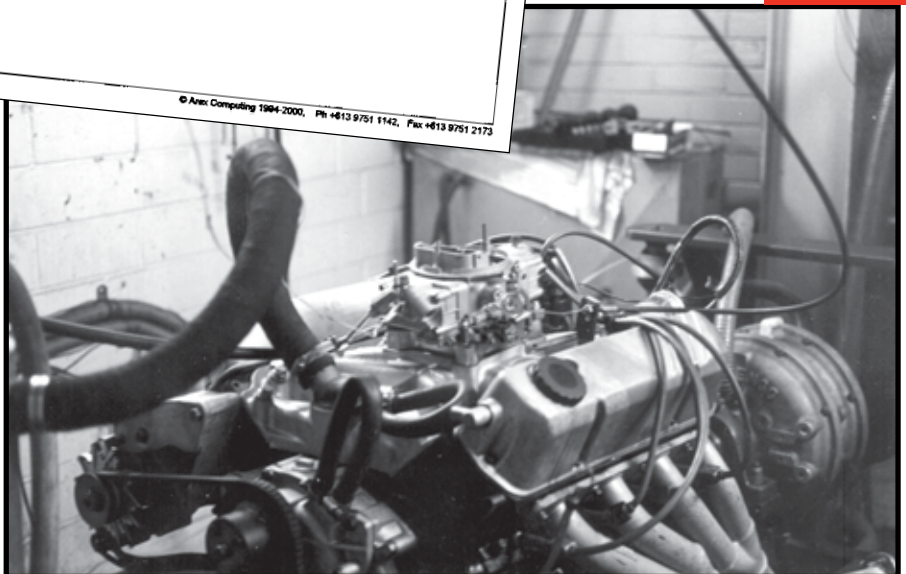

**Dyno Test - part no. 12-116 (by Sam's Performance Engine Dyno)**  
Holden 308 engine modified to 355ci, 10.7 to 1 compression VN cylinder heads fitted, solid cam, headers with 1 3/4" dia, primary pipes, carburettor 830cfm double pumper Holley, distributor timing 28° total, fuel unleaded premium

RPM	HP	Torque
4000	303	398
4500	345.5	403
5000	373.2	392
5500	413	395
6000	438.3	384
6500	450.6	364

**Note**  
The two dyno tests shown were done on two different engines to test out the 12-116 VN Redline induction manifold



Vehicle Make & Model	Engine Details	Carburettor	Choke Tube	Sec. Venturi	Main Jet	Emulsion Tube	Air Jet	Idle Jet	Pump Jet	In. Valve with Exh. Orifice
<b>BMW</b>										
1600-1800	Stock	2 x 40 DCOE	32	4.5	1.30	F9	1.85	45F12	.35	.45
2002	Stock	2 x 45 DCOE	34	5.0	1.30	F9	1.80	50F8	.40	.45
<b>Ford</b>										
Cortina GT	1500,1600	2 x 40 DCOE	28	4.5	1.15	F16	1.50	45F9	.45	.40
Cortina 1600	Mild Cam	2 x 40 DCOE	32	4.5	1.20	F16	1.80	50F9	.40	.50
Cortina	2000cc	1 x 45 DCOE	34	5.0	1.45	F2	1.85	55F4	.50	.50
Cortina Escort	2000cc Mild Cam	2 x 45 DCOE	34	4.5	1.40	F16	1.80	50F6 50F9	.40	.50
105E	997cc Full Comp.	2 x 40 DCOE	30	4.5	1.55	F16	1.80	40F9	.35	Blank
109E	1098cc Full Comp.	2 x 40 DCOE	33	4.5	1.25	F16	1.65	45F9	.40	Blank
113E	1340cc Full Comp.	2 x 40 DCOE	34	4.5	1.30	F16	1.70	45F9	.40	Blank
116E	1498cc Full Comp.	2 x 40 DCOE	36	4.5	1.35	F16	1.65	50F9	.40	Blank
122E	1498cc GT Cortina	2 x 40 DCOE	32	4.5	1.25	F16	1.70	45F9	.35	Blank
<b>GMH</b>										
Holden, Torana	6cyl. Red-Street	3 x 45 DCOE	36	5.0	1.50	F2	1.90	50F8	.40	.50
Holden, Torana	6cyl. Red-Comp.	3 x 45 DCOE	40	5.0	1.55	F2	2.10	50F8	.45	Blank
Holden, Torana	6cyl. Red-Street	1 x 45 DCOE	32	5.0	1.50	F2	1.35	60F3	.45	Blank
Gemini	1600cc	2 x 44 IDF	34	4.5	1.40	F11	2.00	.55	.40	-
Gemini	1600cc	2 x 40 IDF	32	4.5	1.25	F7	1.90	.55	.40	.80
<b>Leyland (BLMC)</b>										
Mini Cooper	998cc Std. Engine	1 x 40 DCOE	30	4.5	1.30	F16	1.90	50F6	.35	Blank
Mini Cooper	998cc Mild Cam	1 x 45 DCOE	32	5.0	1.30	F9	1.65	45F9	.50	.50
Mini Cooper "S"	1275cc Std.	1 x 45 DCOE	34	3.5	1.30	F2	1.75	50F9	.50	.50
Mini Cooper "S"	1275cc Full Comp. Eng.	1 x 45 DCOE	40	3.5	1.95	F2	2.00	50F9	.50	.50
Austin Sprite	948cc Full Comp. Eng.	1 x 45 DCOE	34	5.0	1.50	F2	1.65	50F6	.40	.50
Sprite	948cc 1098cc	1 x 40 DCOE	32	4.5	1.40	F2	1.75	45F9	.50	Blank
Sprite Mk 1,2,3	1098cc Std.	1 x 45 DCOE	32	5.0	1.40	F15	1.80	45F6	.40	.50
Sprite	1098cc Mild Cam & Head	1 x 45 DCOE	34	4.5	1.35	F16	1.80	45F9	.50	.50
Sprite	1098cc Full Comp. Eng.	1 x 45 DCOE	37	3.5	1.80	F2	2.00	50F9	.50	.50
Sprite Mk4	1275cc Std.	1 x 45 DCOE	34	3.5	1.30	F2	1.75	50F9	.50	.50
Sprite	1275cc Full Comp. Eng.	1 x 45 DCOE	40	3.5	2.00	F2	1.95	50F9	.50	.50
Austin Healy 3000	Std. Engine.	3 x 45 DCOE	32	4.5	1.40	F2	1.80	50F2	.45	Blank
Austin Healy 3000	Full Comp. Engine.	3 x 45 DCOE	34	3.5	1.30	F2	1.60	50F2	.45	Blank
Jaguar "E" Type	3.8 & 4.2 Eng	3 x 45 DCOE	38	3.5	1.65	F2	1.90	65F8	.40	.50
MGB	Stock	1 x 45 DCOE	34	3.5	1.45	F2	1.65	50F9	.50	.50
MGB	Full Comp.	1 x 45 DCOE	36	5.0	1.65	F16	1.60	50F8	.60	.50
<b>Mitsubishi</b>										
Colt	1600cc	1 x 45 DCOE	32	5.0	1.25	F20	1.60	50F8	.45	.50
Sigma	2000cc	2 x 45 DCOE	34	3.5	1.30	F2	1.75	50F8	.50	.50
Sigma	2600cc	2 x 45 DCOE	38	4.5	1.45	F2	1.90	55F8	.45	.50
Valiant E37	265ci Hemi 6cyl	3 x 45 DCOE	38	4.5	1.35	F2	1.80	55F9	.50	.50
Valiant E38	265ci Hemi 6cyl	3 x 45 DCOE	40	4.5	1.45	F2	1.80	55F9	.50	.50

Vehicle Make & Model	Engine Details	Carburettor	Choke Tube	Sec. Venturi	Main Jet	Emulsion Tube	Air Jet	Idle Jet	Pump Jet	In. Valve with Exh. Orifice
<b>Nissan (Datsun)</b>										
1000 & 1200	Stock	1 x 40 DCOE	27	4.5	1.10	F7	1.65	50F9	.50	.50
1600	Stock	1 x 45 DCOE	32	5.0	1.30	F20	1.70	45F9	.50	Blank
1800 - 180B	Stock	1 x 45 DCOE	34	5.0	1.40	F20	1.75	45F9	.40	Blank
1800 - 180B	Stock	2 x 40 DCOE	32	4.5	1.40	F15	1.65	50F8	.40	.50
1000 & 1200	Mild Cam	2 x 40 DCOE	30	4.5	1.15	F16	1.85	45F6	.35	.50
1600	Mild Cam	2 x 40 DCOE	33	4.5	1.35	F15	1.60	50F8	.40	.50
1800-180B - SSS	Stock	2 x 45 DCOE	30	4.5	1.20	F15	1.95	50F8	.40	.50
240Z & 260Z	Stock	3 x 40 DCOE	30	4.5	1.30	F2	1.75	50F9	.45	.55
240Z & 260Z	Stock	3 x 45 DCOE	34	5.0	1.45	F15	1.80	55F2	.45	.45
240Z & 260Z	Modified	3 x 45 DCOE	34	5.0	1.30	F16	1.75	55F2	.45	.55
<b>Toyota</b>										
Corolla	Full Comp. Eng.	2 x 40 DCOE	33	4.5	1.20	F16	1.65	45F9	.35	.50
Corolla 1200	Stock	2 x 40 DCOE	28	4.5	1.15	F11	1.60	50F9	.35	.50
Corolla 1200	Stock	1 x 40 DCOE	27	4.5	1.05	F7	1.55	50F11	.50	.50
Corona	Mild Cam	2 x 40 DCOE	30	4.5	1.25	F15	1.80	50F9	.40	.50
Celica 2 Litre	Stock	1 x 45 DCOE	34	5.0	1.40	F2	1.70	45F9	.50	.50
Celica 1600	Stock	1 x 45 DCOE	28	5.0	1.10	F15	2.00	45F9	.50	.50
Celica 1600	Rally	1 x 45 DCOE	32	5.0	1.20	F15	2.00	45F9	.50	.50
Corolla, Carina	1600 (2TC)	1 x 40 DCOE	30	4.5	1.10	F11	2.00	45F9	.50	.50
Carina	1600 (2TC)	2 x 40 DCOE	30	4.5	1.15	F11	2.00	50F9	.40	.50
Celica, Corona, Corona MK2	8RC, 18RC	1 x 40 DCOE	33	4.5	1.60	F2	1.65	40F9	.60	Blank
Celica, Corona, Corona MK2	8RC, 18RC	2 x 40 DCOE	33	4.5	1.40	F2	1.70	45F6	.35	Blank
<b>Volvo</b>										
122S & 144	Stock	2 x 40 DCOE	30	4.5	1.25	F15	1.60	50F8	.50	.50
122S & 144	Full Comp. Eng.	2 x 40 DCOE	34	4.5	1.55	F15	1.70	50F8	.50	.50
P1800	Factory Ext. Exh 30-70 Cam	2 x 45 DCOE	36	4.5	1.50	F15	1.70	50F8	.50	.50
P1800	30-70 Cam	2 x 40 DCOE	32	4.5	1.25	F15	1.60	50F8	.50	.50
<b>V8 Adaptor</b>										
Ford 302ci	Stock	2 x 45 DCOE	34	4.5	1.80	F2	2.00	50F9	.50	.50
Ford 351ci	Stock	2 x 45 DCOE	36	4.5	2.00	F2	1.90	50F9	.50	.50
Ford 302ci	Competition	2 x 45 DCOE	42	3.5	2.40	F4	1.80	50F9	.40	Blank
GMH 308ci	Stock	2 x 45 DCOE	30	5.0	1.60	F15	2.00	50F8	.40	.50
GMH 308ci	Competition	2 x 45 DCOE	38	5.0	2.45	F15	1.80	50F8	.40	.45

**Note**

Please understand that the above jetting chart is only a guide and some changes may have to be made due to the different grades of fuel used in cars today. Octane levels are far different to the fuels used when this chart was established.



**14-26**  
**Fuel elbow 5/16"od**  
Suit 2bbl Holley 7448 and Stromberg carbs

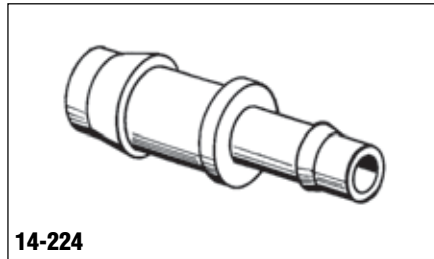

**14-224**  
**Nylon reducing joiner**  
10mm x 6mm dia



**14-53**  
**14-54**  
**Chrome dual fuel line 3/8"od**  
**14-53** To suit 750cfm Holley 4bbl carb 8 21/32" between bowls with 1/8"npt thread to suit fuel pressure gauge (Redline Part No. 14-64)  
**14-54** To suit D/P Holley 4bbl carb 9 5/16" between bowls with 1/8"npt thread to suit fuel pressure gauge (Redline Part No. 14-64)



**14-27**  
**Fuel elbow 3/8"od**  
Suit 4bbl Holley 600cfm-650cfm carb

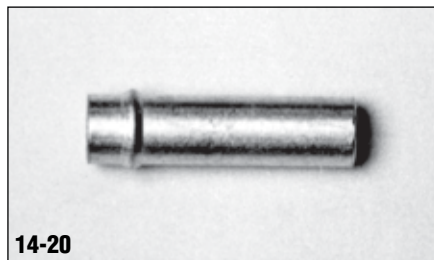

**14-20**  
**Spout 3/8" diameter**  
Suit Carburettor PCV

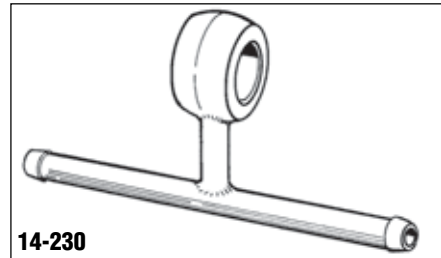

**14-230**  
**Fuel Banjo T Piece**  
8mm (5/16") tube size suit DCOE Weber Carb

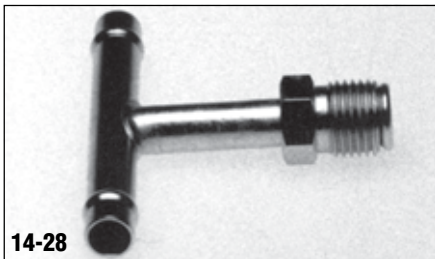

**14-28**  
**Threaded 5/16"od T piece**  
Suits Holley & Stromberg carbs

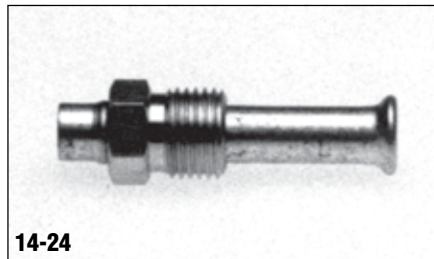

**14-24**  
**Straight 5/16" fuel fitting**  
Suit Holley & Stromberg Carburettors

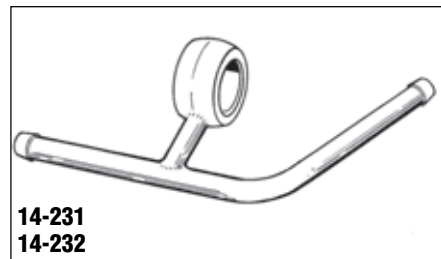

**14-231**  
**14-232**  
**Fuel Banjo T Piece**  
**14-231** R/H Elbow 8mm (5/16") tube size suit DCOE Weber  
**14-232** L/H Elbow 8mm (5/16") tube size suit DCOE Weber

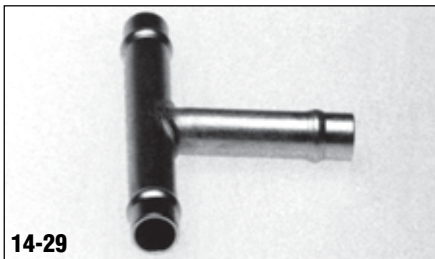

**14-29**  
**Plain 5/16"od T piece**

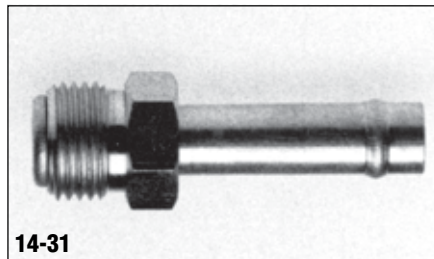

**14-31**  
**Straight 3/8" fuel fitting**  
Suit Holley 1850, 3310 etc Carburettors

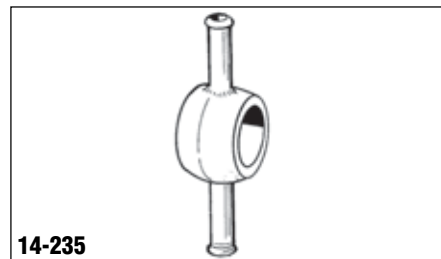

**14-235**  
**Fuel Double Banjo**  
**14-235** 6.3mm (1/4") tube size suit DCOE Weber





**14-238**

**Fuel Banjo 90° Elbow**

8mm (5/16") tube size suit DCOE Weber

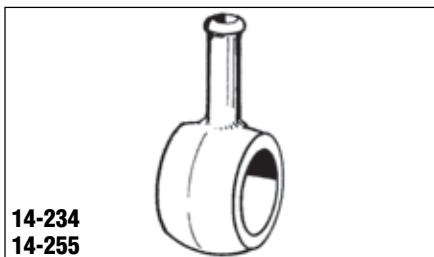

**14-234**  
**14-255**

**Fuel Banjo Straight**

**14-234** 6.3mm (1/4") tube size  
suit DCOE Weber

**14-255** 8mm (5/16") tube size  
suit DCOE Weber

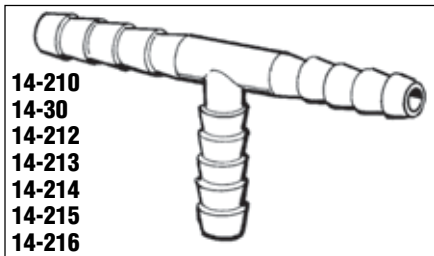

**14-210**  
**14-30**  
**14-212**  
**14-213**  
**14-214**  
**14-215**  
**14-216**

**Nylon T piece**

**14-210** 4.8mm (3/16")

**14-30** 6.3mm (1/4")

**14-212** 8mm (5/16")

**14-213** 9.5mm (3/8")

**14-214** 12.7mm (1/2")

**14-215** 15.9mm (5/8")

**14-216** 19mm (3/4")



**14-12**

**Fuel line adaptor**

Suit 1/8"npt fuel pressure gauge. Use 1/8"bsp fittings each end. Select size to suit fuel line. Use compression fittings for steel line. Use barb fittings for fuel hose



**14-39**  
**14-40**  
**14-41**  
**14-42**

**Brass Barb Fitting**

**14-39** 1/8"bsp x 6.3mm (1/4")

**14-40** 1/8"bsp x 8mm (5/16")

**14-41** 1/8"bsp x 9.5mm (3/8")

**14-42** 1/8"bsp x 4.8mm (3/16")

All these fittings suit 14-12 fuel line adaptor and Redline Fuel Pressure Regulators



**14-32**  
**14-33**  
**14-34**

**Brass Barb Fitting**

**14-32** 1/4"npt x 6.3mm (1/4")

**14-33** 1/4"npt x 8mm (5/16")

Suits Holley mechanical fuel pumps, also fits 14-70 Triple Fuel Block

**14-34** 1/4"npt x 9.5mm (3/8")

Suits Holley mechanical fuel pumps, also fits 14-70 Triple Fuel Block



**14-43**

**Brass Barb Fitting**

**14-43** 1/4"bsp x 12.5mm (1/2")



**14-38**  
**14-44**

**Brass Barb Fitting**

To suit Holley electric fuel pumps etc.

**14-38** 3/8"npt x 8mm (5/16"). Pack of 2

**14-44** 3/8"npt x 9.5mm (3/8"). Pack of 2  
Suits Holley electric fuel pumps etc and 14-70 Triple Fuel Block

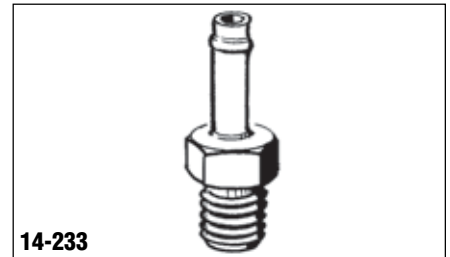

**14-233**

**Brass Barb Fitting**

12mm x 6.3mm (1/4")

Suit DCN Weber caburettor

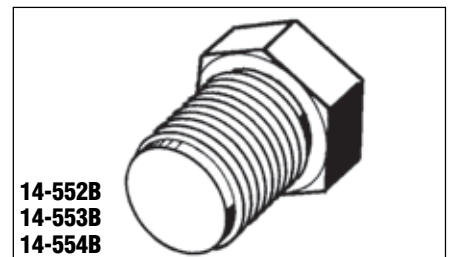

**14-552B**  
**14-553B**  
**14-554B**

**Brass Plug**

**14-552B** 1/8"bsp thread

**14-553B** 1/4"bsp thread

**14-554B** 3/8"bsp thread



**14-14FH**  
**14-516FH**  
**14-38FH**

**Black Rubber Fuel Hose**

**14-14FH** 6.3mm (1/4") id

**14-516FH** 8mm (5/16") id

**14-38FH** 9.5mm (3/8") id

Order by the metre



**14-617**

**Fuel Line Hose Clamps**

Worm drive type, suits 1/4", 5/16" and 3/8" fuel hose.

Pack of 6, can also be purchased in bulk quantities



14-60  
14-61  
14-62

**Adjustable Fuel Injection Pressure Regulator 0 to 150lbs**

- 14-60 Chrome
- 14-61 Red
- 14-62 Blue



14-80

**Hi-flow fuel pump inlet & exhaust valves**

Suit Holden 253-308 mechanical fuel pumps & Holley chrome hi-volume fuel pumps. Fits any mechanical fuel pump with 25mm (1") diameter valves. Increase fuel flow with these special design hi-flow valves - the largest fuel flowing valves available. Packet of 2.



14-351

**Standard Replacement Fuel Pump**

To suit 302-351 Ford Cleveland V8



14-64

**Chrome Fuel Pressure Gauge 0-15psi**

1 5/8" dia.  
For use with carburettor engines.  
Fits Redline fuel lines Part Nos. 14-53, 14-54

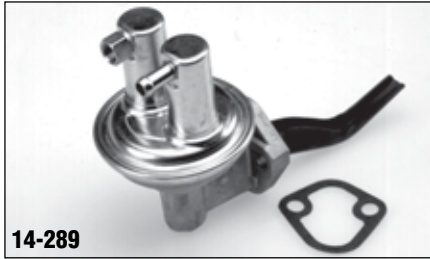

14-289

**Standard Replacement Fuel Pump**

To suit 289-302 Ford Windsor V8



14-804  
14-805  
14-806

**Glass Inline fuel filter**

- 14-804 Suit 1/4" fuel line
- 14-805 Suit 5/16" fuel line
- 14-806 Suit 3/8" fuel line



14-65  
14-66

**Chrome Fuel Pressure Gauge 0-150psi**

1 3/4" dia.  
For use with EFI engines.

- 14-65 Oil filled
- 14-66 Not oil filled



14-309

**Fuel pump**

To suit 253-308 Holden V8



14-854

**Inline fuel pressure regulator 5/16" fittings**

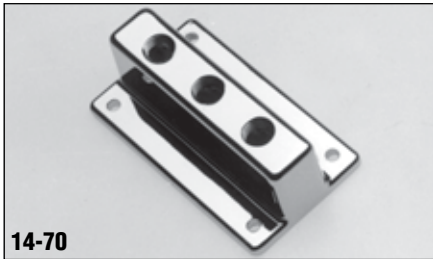

14-70

**Chrome Triple Fuel Block**

Use 3/8"NPT fitting in one end and 1/4"NPT fittings in the top. Select fitting size to suit fuel line being used.  
Fittings not supplied with fuel block.



14-350  
14-349

**Standard Replacement Fuel Pump**

To suit Chevy Small Block 283-350 V8

- 14-350 Suit 5/16" dia fuel lines
- 14-349 Suit 3/8" dia x fuel lines



14-896

**Replacement fuel filter elements**

Pack of 3

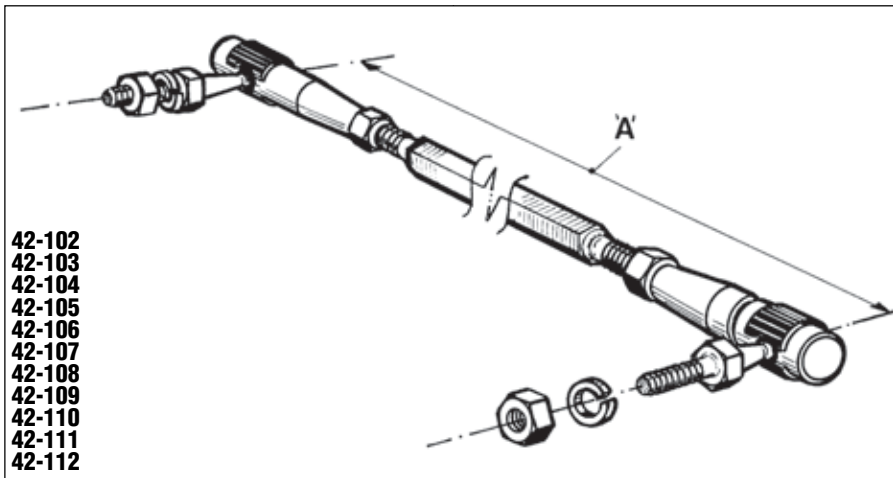

- 42-102
- 42-103
- 42-104
- 42-105
- 42-106
- 42-107
- 42-108
- 42-109
- 42-110
- 42-111
- 42-112

**Adjustable Ball Joint Linkage**  
Provides 25mm (1") Adjustment

- 'A'
- 42-102 70mm (2 3/4")
  - 42-103 95mm (3 3/4")
  - 42-104 120mm (4 3/4")
  - 42-105 145mm (5 3/4")
  - 42-106 170mm (6 3/4")
  - 42-107 195mm (7 3/4")
  - 42-108 220mm (8 3/4")
  - 42-109 245mm (9 3/4")
  - 42-110 270mm (10 3/4")
  - 42-111 295mm (11 3/4")
  - 42-112 320mm (12 3/4")

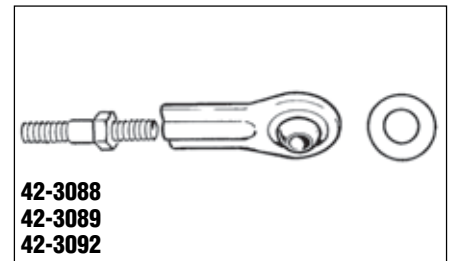

- 42-3088
- 42-3089
- 42-3092

**Adjustable Uniball**  
**42-3088** 5/16"unc thread  
suit 8mm (5/16") Round Drive Shaft  
**42-3089** 5/16"unc thread  
suit 8mm (5/16") Round Drive Shaft  
**42-3092** 3/8"unc thread  
suit 8mm (5/16") Round Drive Shaft

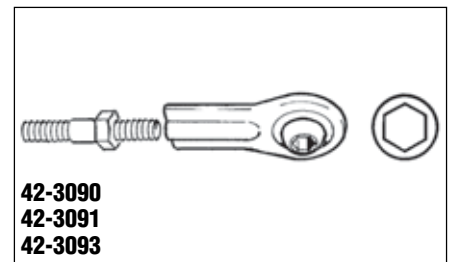

- 42-3090
- 42-3091
- 42-3093

**Adjustable Uniball**  
**42-3090** 5/16"unc thread  
suit 7mm Hexagon Drive Shaft  
**42-3091** 5/16"unc thread  
suit 7mm Hexagon Drive Shaft  
**42-3093** 3/8"unc thread  
suit 7mm Hexagon Drive Shaft

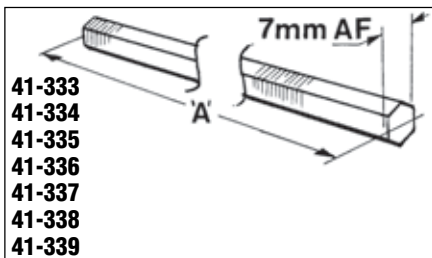

- 41-333
- 41-334
- 41-335
- 41-336
- 41-337
- 41-338
- 41-339

**Hexagon Drive Shaft**  
7mm a/f

- 41-333 155mm (6") long
- 41-334 255mm (10") long
- 41-335 305mm (12") long
- 41-336 380mm (15") long
- 41-337 455mm (18") long
- 41-338 535mm (21") long
- 41-339 610mm (24") long

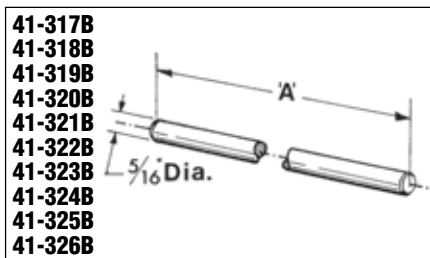

- 41-317B
- 41-318B
- 41-319B
- 41-320B
- 41-321B
- 41-322B
- 41-323B
- 41-324B
- 41-325B
- 41-326B

**Round Drive Shaft**  
8mm (5/16") od

- 41-317B 65mm (2 1/2") long
- 41-318B 95mm (3 3/4") long
- 41-319B 115mm (4 1/4") long
- 41-320B 150mm (6") long
- 41-321B 255mm (10") long
- 41-322B 305mm (12") long
- 41-323B 380mm (15") long
- 41-324B 455mm (18") long
- 41-325B 535mm (21") long
- 41-326B 610mm (24") long

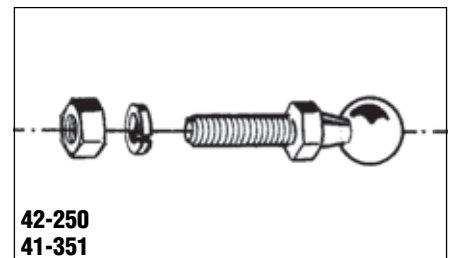

- 42-250
- 41-351

**Throttle Ball**  
**42-250** 6mm (1/4") od  
**41-351** 8mm (5/16") od

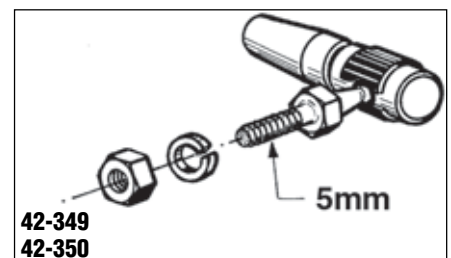

- 42-349
- 42-350

**Ball Joint End only**  
**42-349** Right Hand thread (Brass)  
**42-350** Left Hand thread (Brass)



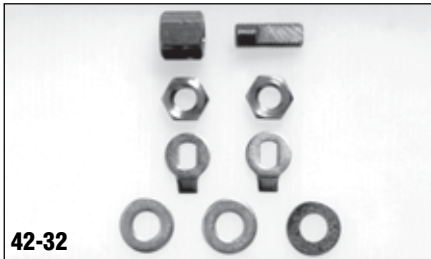

**42-32**

**Throttle Shaft Extension Kit**

suit 2bbl DGV, DGAV Weber

& 2bbl 180cfm Holley Carburetors

NOTE: The new assembly has now moved the throttle lever 21mm further away from the carb body. Adjustment can be made by placing more or less spacing washers to locate lever arm at desired distance.

**Assembly instructions**

- 1 Remove nut and tab washer from carburettor throttle shaft.
- 2 Remove original throttle lever and replace with 2 flat washers.
- 3 Install tab washer and extension nut supplied in kit. Tighten extension nut firmly and secure with tab washer.
- 4 Screw extension shaft into nut and tighten lightly.
- 5 Install tab washer and 1st locknut and tighten securely.
- 6 Install new throttle lever and rotate to desired position.
- 7 Install original tab washer and 2nd locknut and tighten securely. Bend all lock tabs over to prevent assembly from working loose.

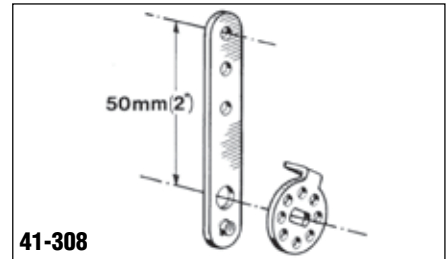
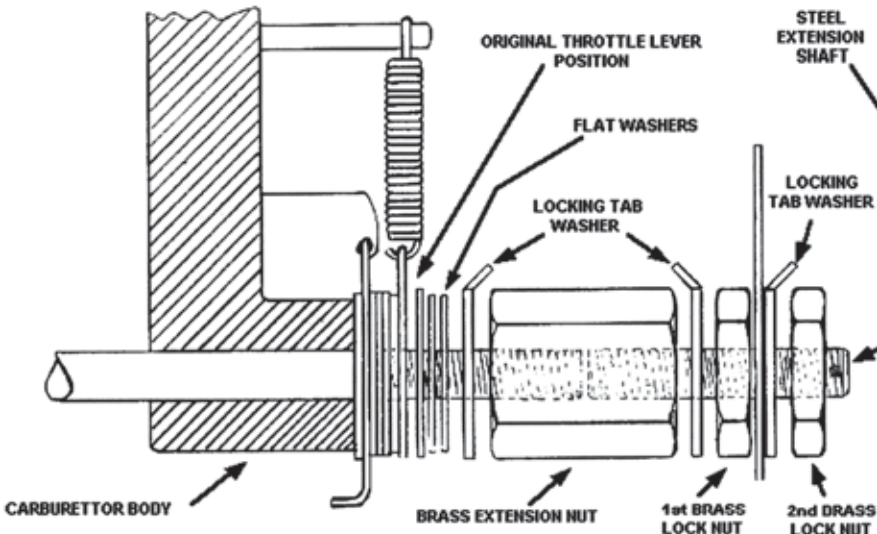

**41-308**

**Lever Arm**

L/H 360° Adjustable

Universal suit DCOE Weber Carburettor

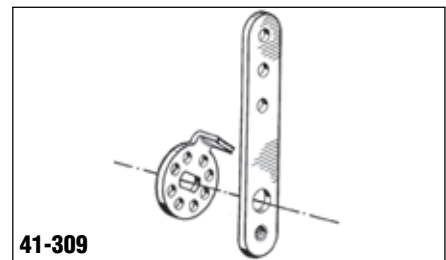

**41-309**

**Lever Arm**

R/H 360° Adjustable

Universal suit DCOE Weber Carburettor

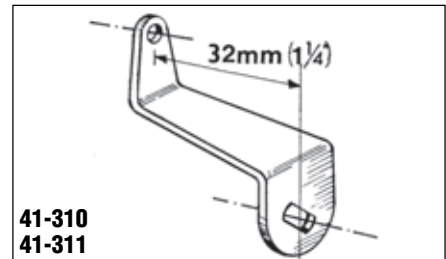

**41-310  
41-311**

**Lever Arm**

**41-310** R/H 32mm offset fixed

suit DCOE, DCN, IDA Weber Carbs

**41-311** L/H 32mm offset fixed

suit DCOE, DCN, IDA Weber Carbs

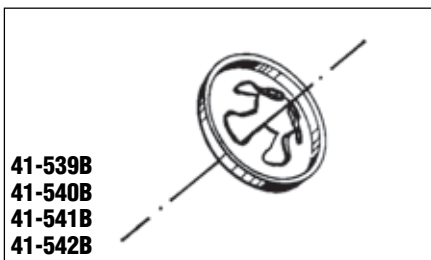

**41-539B  
41-540B  
41-541B  
41-542B**

**Shaft Stop**

**41-539B** Suit 1/16"od Round Shaft

**41-540B** Suit 3/16"od Round Shaft

**41-543B** Suit 1/4"od Round Shaft

**41-541B** Suit 5/16"od Round Shaft

**41-542B** Suit 7mm Hexagon Shaft

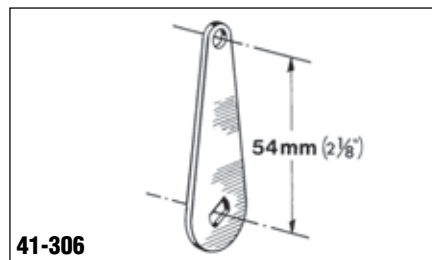

**41-306**

**Lever Arm**

Suit DCOE, DCN, IDA Weber Carburettor

Fixed position



**42-09**

**Shaft Stop**

Suits 7mm hexagon & 8mm (5/16") round shafts

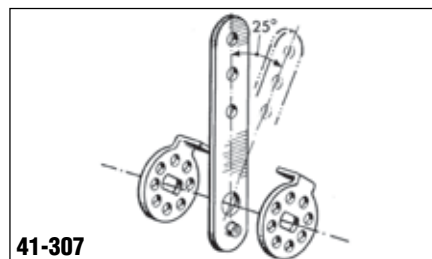

**41-307**

**Lever Arm**

L/H & R/H 360° Adjustable

Universal suit DCOE Weber Carburettor

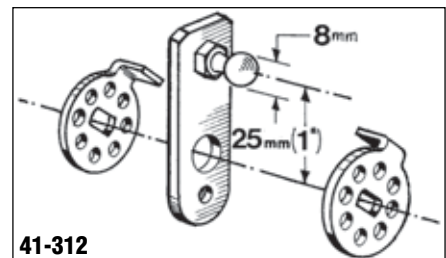

**41-312**

**Lever Arm**

Short with 8mm ball L/H & R/H 360°

Adjustment suit DCOE Weber

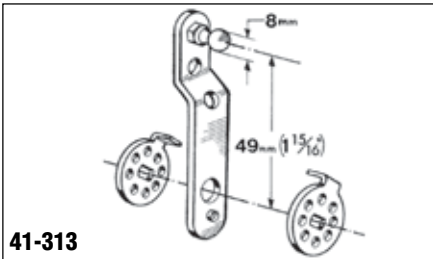

**41-313**  
**Lever Arm**  
Long with 8mm ball L/H & R/H 360°  
Adjustment suit DCOE Weber

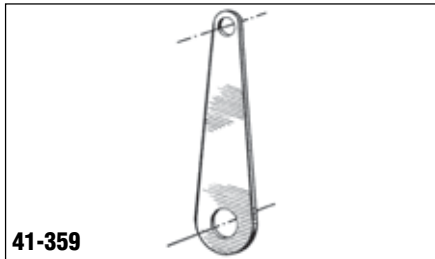

**41-359**  
**Spring Tag**  
(for holding return spring)



**42-15**  
**42-16**  
**Accelerator Return Spring**  
42-15 1 1/2" long  
42-16 3" long

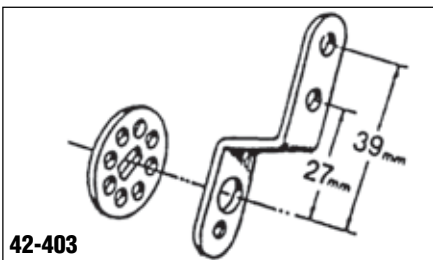

**42-403**  
**Lever Arm**  
Offset 360° Adjustment suit DGV Weber  
& 180cfm Holley Carburetors

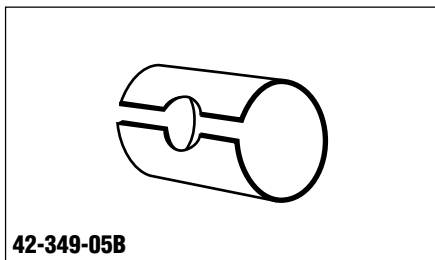

**42-349-05B**  
**Ball Joint Retaining Clip**  
Fits ball joint linkages



**42-19**  
**Accelerator Return Spring 3" long**  
Light weight

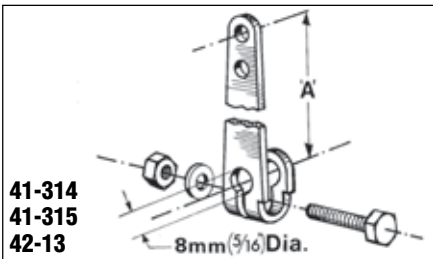

**41-314**  
**41-315**  
**42-13**  
**Lever Arm**  
41-314 23mm (1 5/16") long  
to suit 8mm (5/16") round shaft  
41-315 38mm (1 1/2") long  
to suit 8mm (5/16") round shaft  
42-13 51mm (2") long  
to suit 8mm (5/16") round shaft



**42-404**  
**Outer Cable Holder**

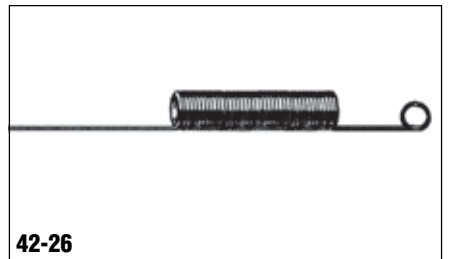

**42-26**  
**Accelerator Return Spring**  
Main body length 50mm, total length 300mm

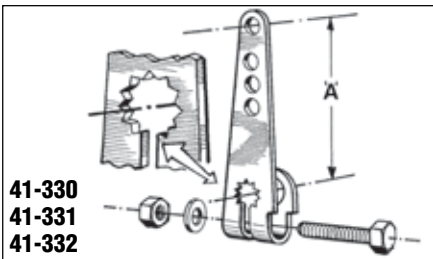

**41-330**  
**41-331**  
**41-332**  
**Lever Arm**  
41-330 23mm (1 5/16") long to suit 7mm  
(5/16") Hexagon shaft (Non-Slip)  
41-331 38mm (1 1/2") long to suit 7mm  
(5/16") Hexagon shaft (Non-Slip)  
41-332 51mm (2") long to suit 7mm  
(5/16") Hexagon shaft (Non-Slip)

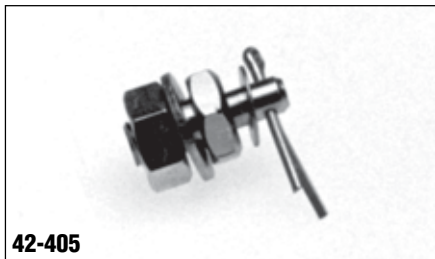

**42-405**  
**Inner Cable Holder**

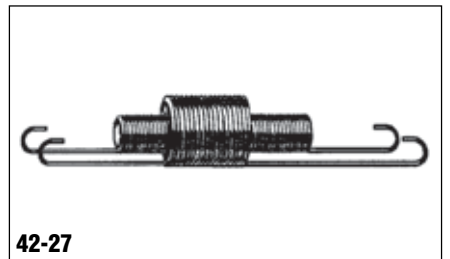

**42-27**  
**Accelerator Return Dual Spring System**  
total length 100mm (4")

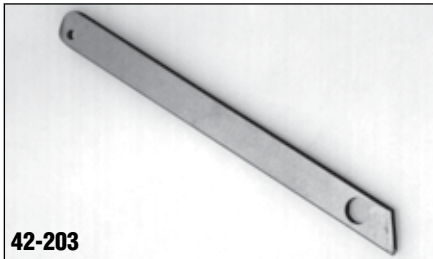

**42-203**

**Accelerator Spring Retaining Bracket**  
for 42-25 Linkage kit



**41-869B**

**Cable Bracket Universal**



**42-14**

**Bracket (Chrome) Universal**  
Suit return spring



**42-204**

**Accelerator Cable Bracket**  
for 42-25 Linkage kit



**42-10**  
**42-11**

**Cable Bracket**

- 42-10** To suit XC-XE Falcon V8 fitted with 4bbl Holley Squarebore  
**42-11** To suit XC-XE Falcon V8 fitted with 2bbl Holley

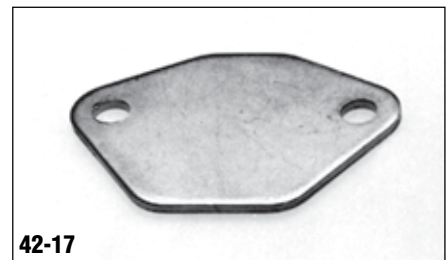

**42-17**

**EGR Blanking plate**  
Suits most 4, 6 & 8cyl Manifolds



**42-65**  
**42-66**

**Accelerator Cable support bracket**

- 42-65** Suit 6cyl HJ-HX Holden fitted with 350cfm Holley 2bbl. Use V8 Cable  
**42-66** Suit 6cyl WB Holden & Commodore fitted with 350cfm Holley 2bbl. Use V8 Cable



**42-10K**  
**42-11K**

**Cable Bracket & Accel. Ball 1/4"**

- 42-10K** To suit XC-XE Falcon V8 fitted with 4bbl Holley Squarebore  
**42-11K** To suit XC-XE Falcon V8 fitted with 2bbl Holley



**42-18**

**Automatic Transmission Kickdown Lever**  
Suits Holley carb no. 1850 and 7397 etc. Also suits Ford C4 & FMX automatic transmissions. Packet of 1



**41-878**

**Accelerator Cable Bracket**  
Suit Gemini fitted with 32/36 DGV Weber Carb



**42-12**

**Kickdown Lever**  
Suit Ford C4 & FMX Auto using some 4bbl Holley Carburettors

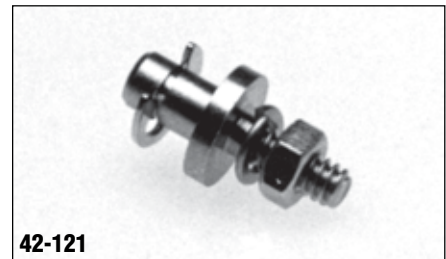

**42-121**

**Stud & Circlip for auto transmission**  
Kickdown lever. Fits 42-12 Redline lever arm





**42-154**  
**Extension Arm**  
Suit Ford C4 & FMX Transmission kickdown lever arm



**42-300**  
**Cable Support Bracket**  
Fits 42-22, 42-23, 42-24 Redline Linkage Kits

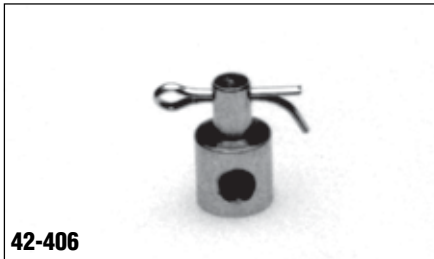

**42-406**  
**Threaded Pin**  
To suit 42-24 linkage Kit



**42-200**  
**Main Linkage Bracket**  
Fits 42-20 Redline Linkage kit



**42-301**  
**Cable Retainer with Circlip**  
To suit 42-22 Redline Linkage kit



**42-407**  
**Adjustable linkage rod**  
Suits 42-24 Redline Linkage kits

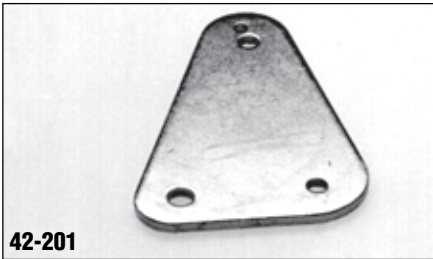

**42-201**  
**Linkage Cam**  
Fits 42-20 Redline Linkage kit

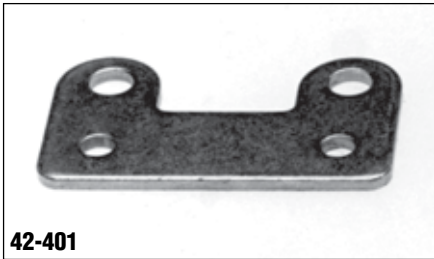

**42-401**  
**Linkage Support Bracket**  
Suits 42-21 Redline Linkage Kit

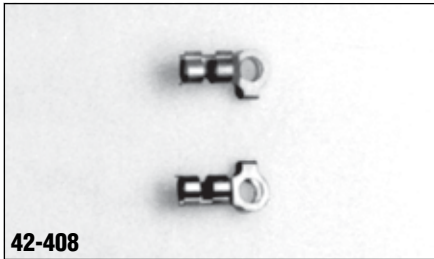

**42-408**  
**Retaining Circlip**  
Right Hand. Fits 42-24 Redline Linkage Kit

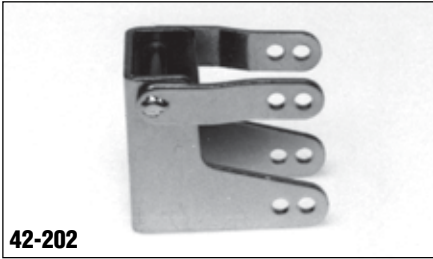

**42-202**  
**Main Linkage Bracket**  
Fits 42-24 Redline Linkage kit

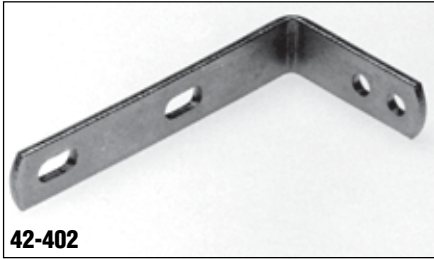

**42-402**  
**Cable Bracket**  
Fits 42-21 & 42-23 Redline Linkage kits

IMAGE  
NOT  
AVAILABLE

**42-233**

**Accelerator Cable Support Bracket**  
Chrome 4bbl Acceleration Linkage bracket



**42-620**

**Kickdown Lever**  
Chrome Auto Transmission Kick down / .  
Acceleration bracket - suits SB Chevy

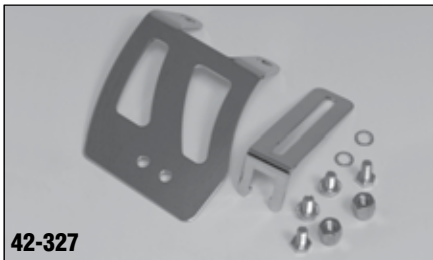

**42-327**

**Accelerator Cable Support Bracket**  
Chrome Accelerator Cable Bracket



**42-03**

**Kickdown lever suits Turbo 700**



**42-328**

**Kickdown Lever**  
Chrome Turbo 350 transmission Kick down  
bracket

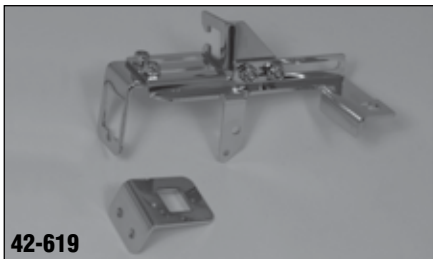

**42-619**

**Accelerator Cable Support Bracket**  
Chrome Auto Transmission kick down bracket  
kit - suits SB Chevy



**46-251**

**Choke Cable**

1220mm long (4 feet). Universal fitment



**46-376**

**Throttle Cable**

Spring Loaded Adjustable 8mm (5/16") dia Ball end fitting.  
Inner cable 1800mm, outer cable 1600mm, stroke 62mm (2 1/2")



**46-353**

**Throttle Cable**

Outer cable 838mm (33"), inner cable 1143mm (45")



**46-252**

**Throttle Cable**

Outer cable 1530mm (60"), inner cable 1665mm (65")



**46-254**

**Throttle Cable**

Adjustable Both Ends  
One end suits 8mm (5/16") dia throttle ball.  
Outer cable 1380mm (54"), inner cable 1602mm (63")

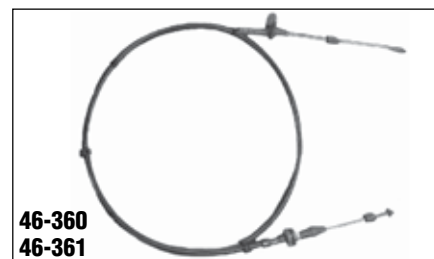

**46-360**

**46-361**

**Shifter Cable**

**46-360** Suits all B&M automatic transmission shifters  
**46-361** Suits all Hurst automatic transmission shifters



**46-253**

**Throttle Cable**

Outer cable 660mm (26"), inner cable 910mm (36")  
This cable will suit the Mini Minor 850 throttle

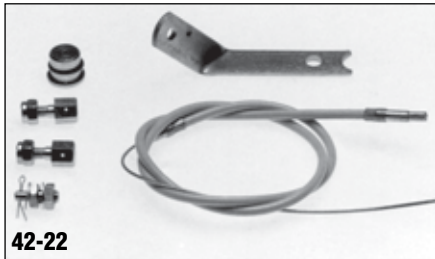
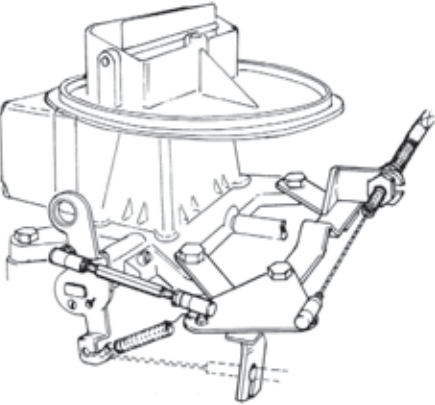

Photo by Jon Van Daal





**42-20**  
**Linkage kit**  
to suit 2bbl Holley carb on Ford 6cyl X-flow using Redline 12-43, 12-46, 12-70 & 12-71 inlet manifolds



**42-22**  
**Linkage kit**  
to suit 2bbl Holley carb on HQ 6cyl Holden fitted with a Redline 12-65 intake manifold

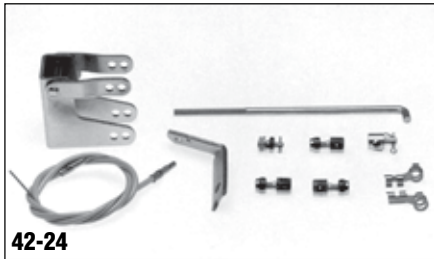
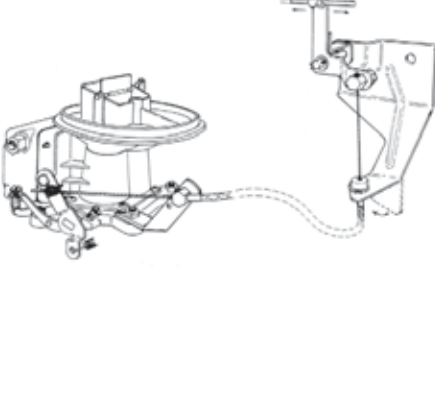

**42-24**  
**Linkage kit**  
to suit 2bbl Holley carb on 6cyl Holden HD, HR, HK, HT, HG fitted with a Redline 12-65 intake manifold

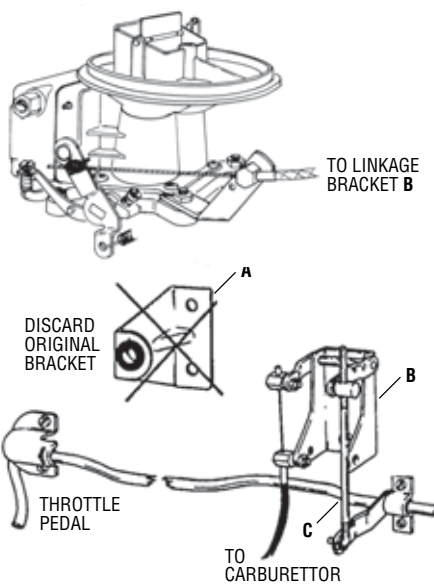

**HD-HR MODELS**

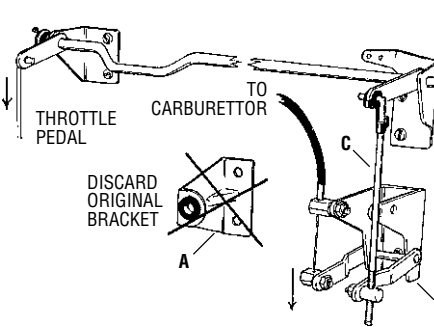

**HK-HT-HG MODELS**

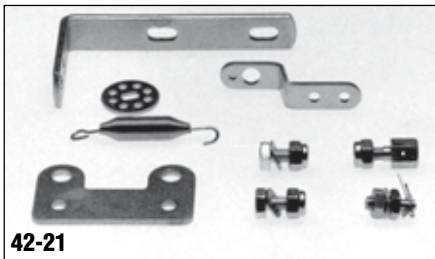

**42-21**  
**Linkage kit**  
to suit 2bbl Weber or 180cfm Holley downdraught carb on Redline adaptors

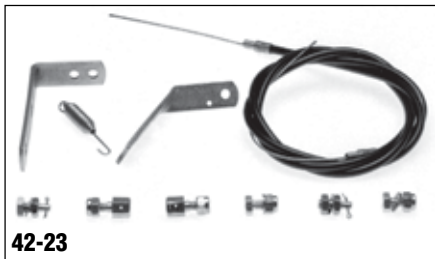
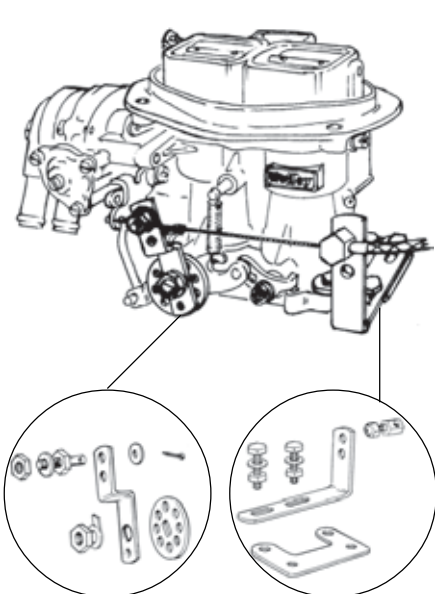

**42-23**  
**Linkage kit**  
to suit 2bbl Holley carburettor. Universal fitment

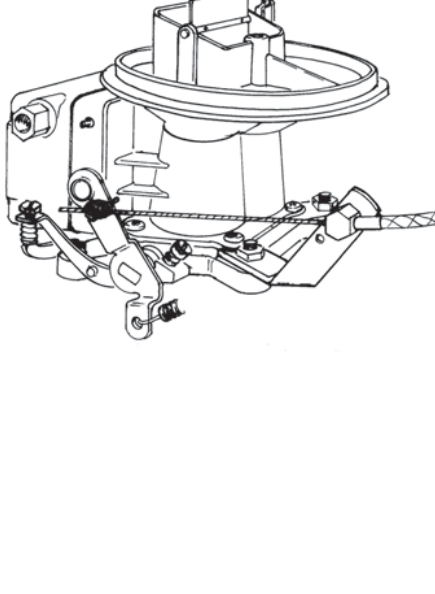

Remove original linkage bracket **A** and fit Redline linkage bracket **B** in its place as illustrated using original 1/4" Whit. screws. Adjustable rod **C** fits to original linkage using clips supplied 1 L/H & 1 R/H (one fits HD-HR, one fits HK-HG). Linkage bracket **B** has several holes for adjustment. (Registered design) Linkage rod **C** is also adjustable so accelerator pedal movement can be set at its best position.



**42-25**

**Linkage kit**  
to suit Holden 6 cylinder 1964-on fitted with triple 1 3/4" SU carburettors.

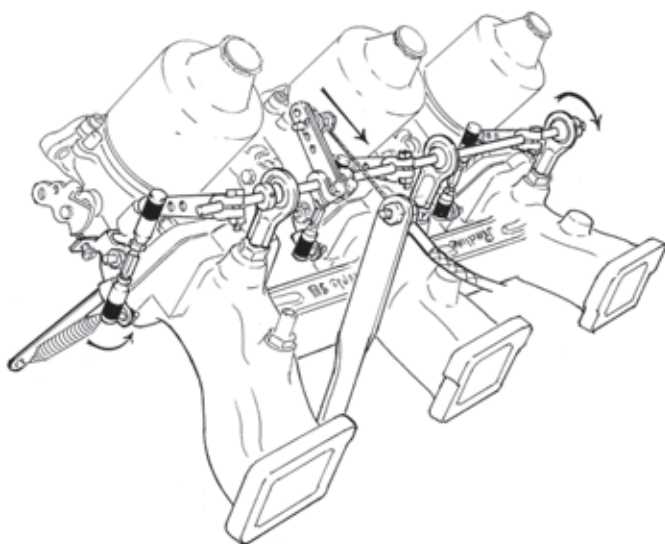

**42-30**

**Linkage kit**  
to suit Holden 308 fitted with Redline Quad IDF Weber inlet manifold No.12-308/12-100

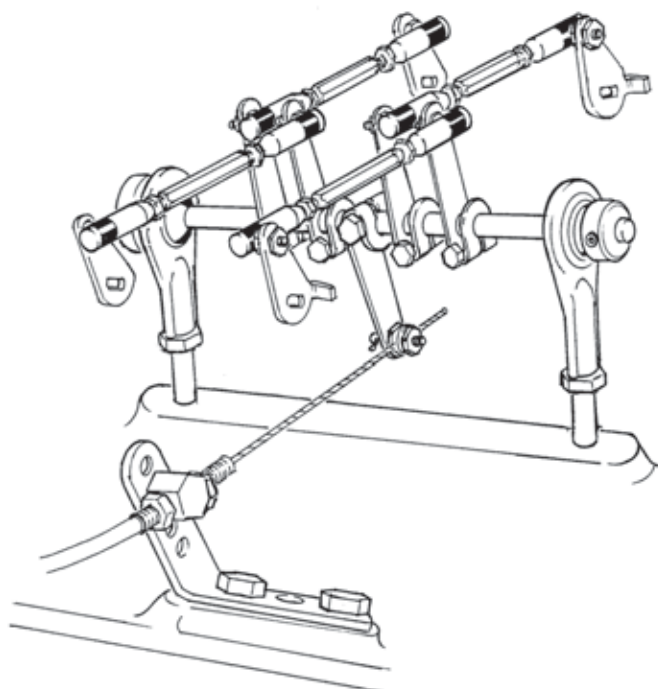

**42-31**

**Linkage kit**  
to suit Ford 351 Cleveland fitted with Redline Quad IDF Weber inlet manifold No.12-351/12-101

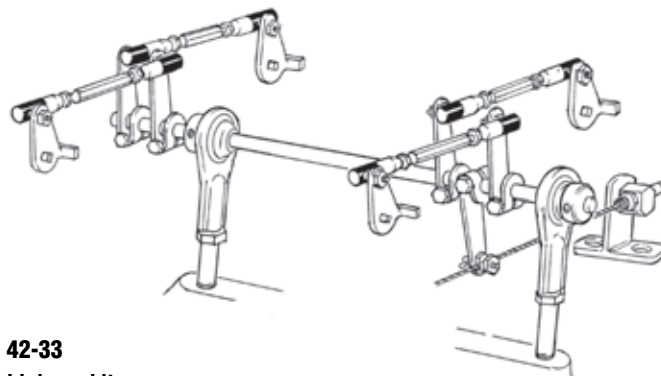

**42-33**

**Linkage kit**  
to suit Holden 308 fitted with Redline Quad IDA Weber inlet manifold No.12-308/12-105

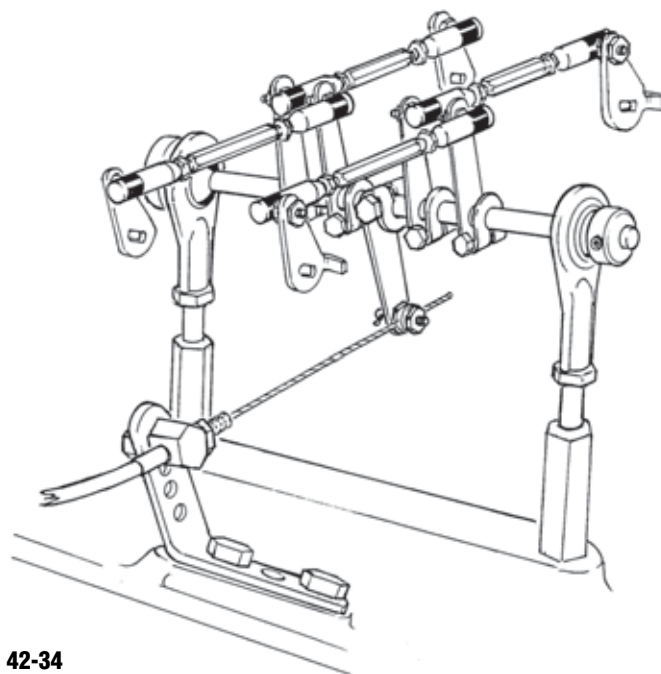

**42-34**

**Linkage kit**  
to suit Ford 351 Cleveland fitted with Redline Quad IDA Weber inlet manifold No.12-351/12-106

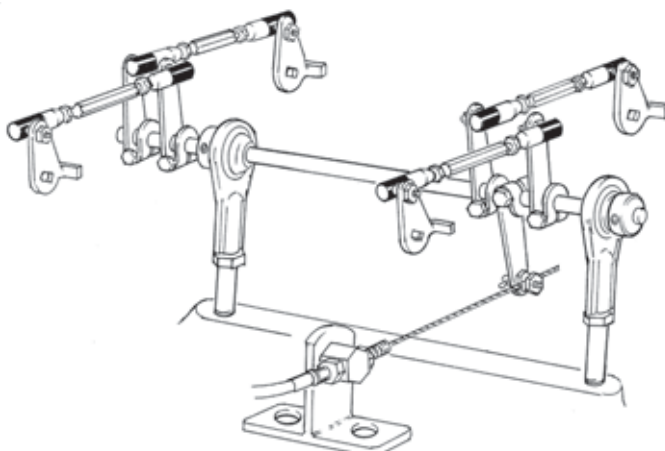



**LP1000  
LP2000**

**Linkage for DCOE Carburettors**

**LP1000** Top mounting for single cable operation. Incorporates clamp-on ferrule for use with existing throttle cable

**LP2000** Top mounting for twin cable operation, kit includes twin cables

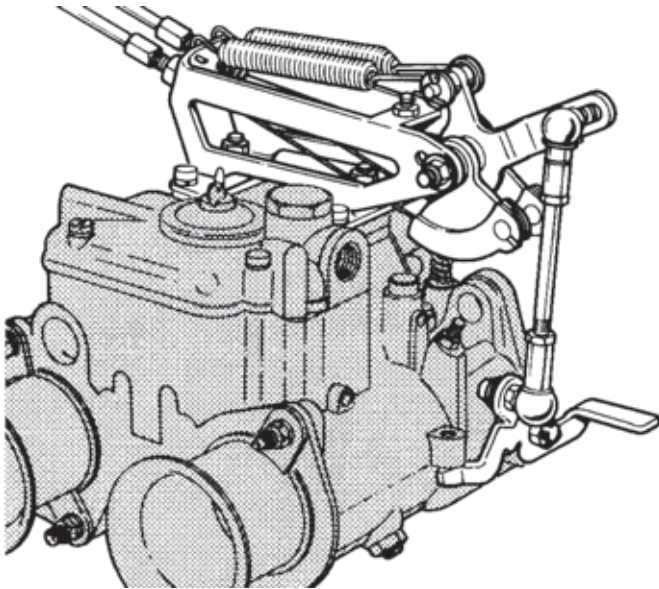

**LP3000  
LP4000**

**Linkage for DCOE Carburettors**

**LP3000** Bottom mounting for single cable operation. Incorporates clamp-on ferrule for use with existing throttle cable

**LP4000** Bottom mounting for twin cable operation, kit includes twin cables

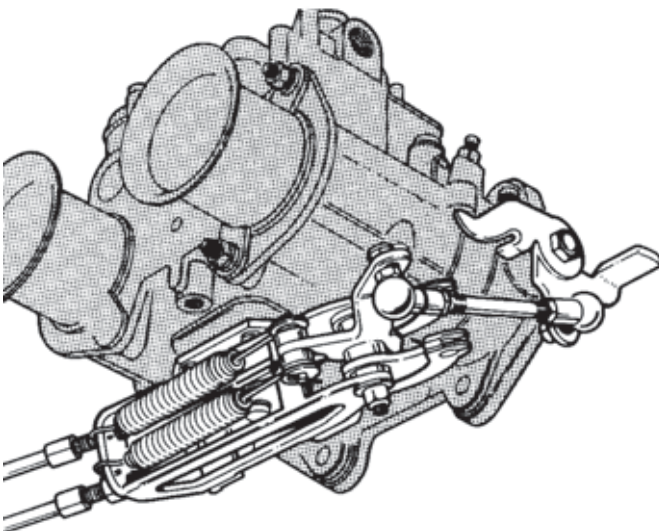

**42-2654**

**Universal single manifold conversion kit**

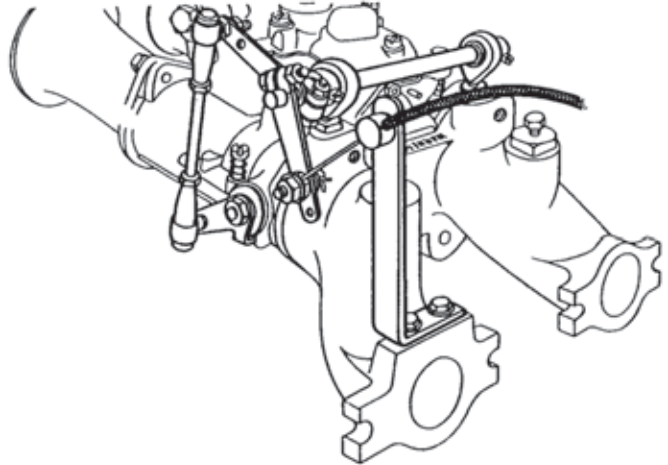

**42-2655**

**Universal dual manifold conversion kit**

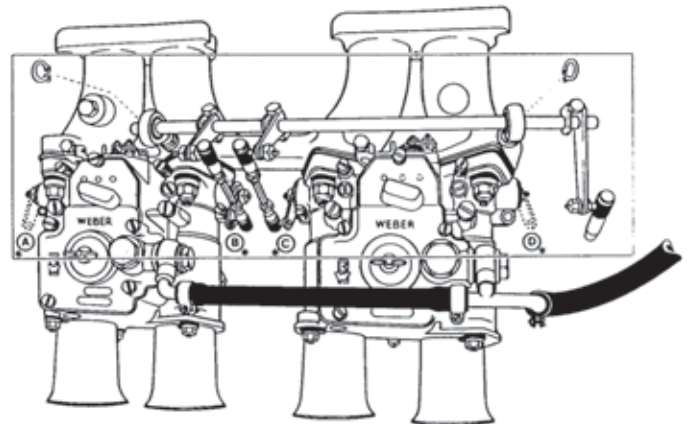

**42-2653**

**Universal triple manifold conversion kit**

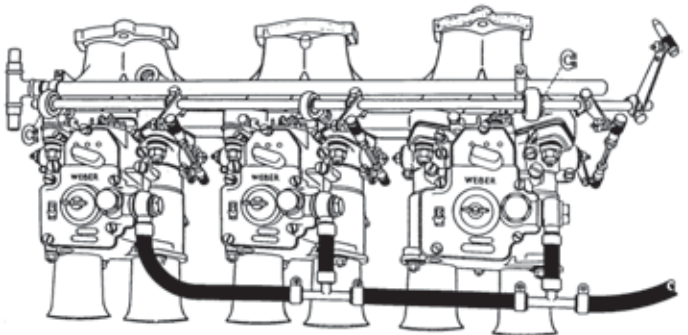



**42-35**

**Cable linkage kit**  
to suit LC-LJ Torana fitted with triple SU or CD carburettors

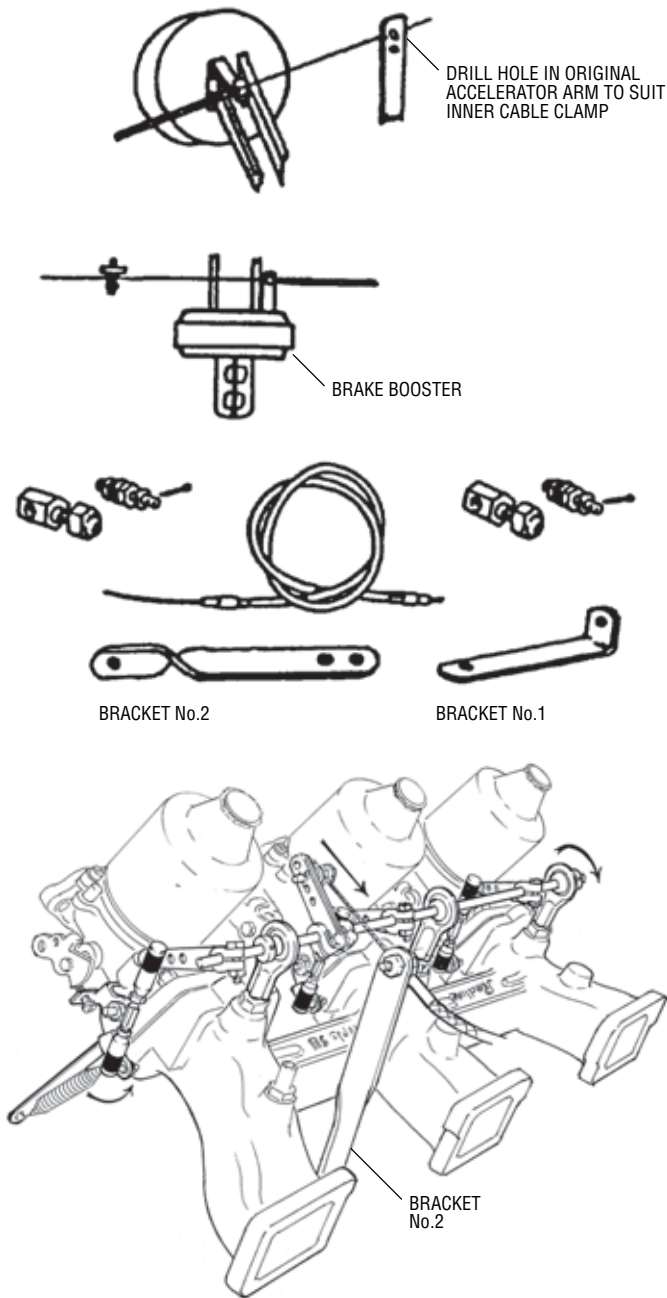

**42-36**

**Cable linkage kit**  
to suit LC-LJ Torana 6 cylinder using Holley carburettor

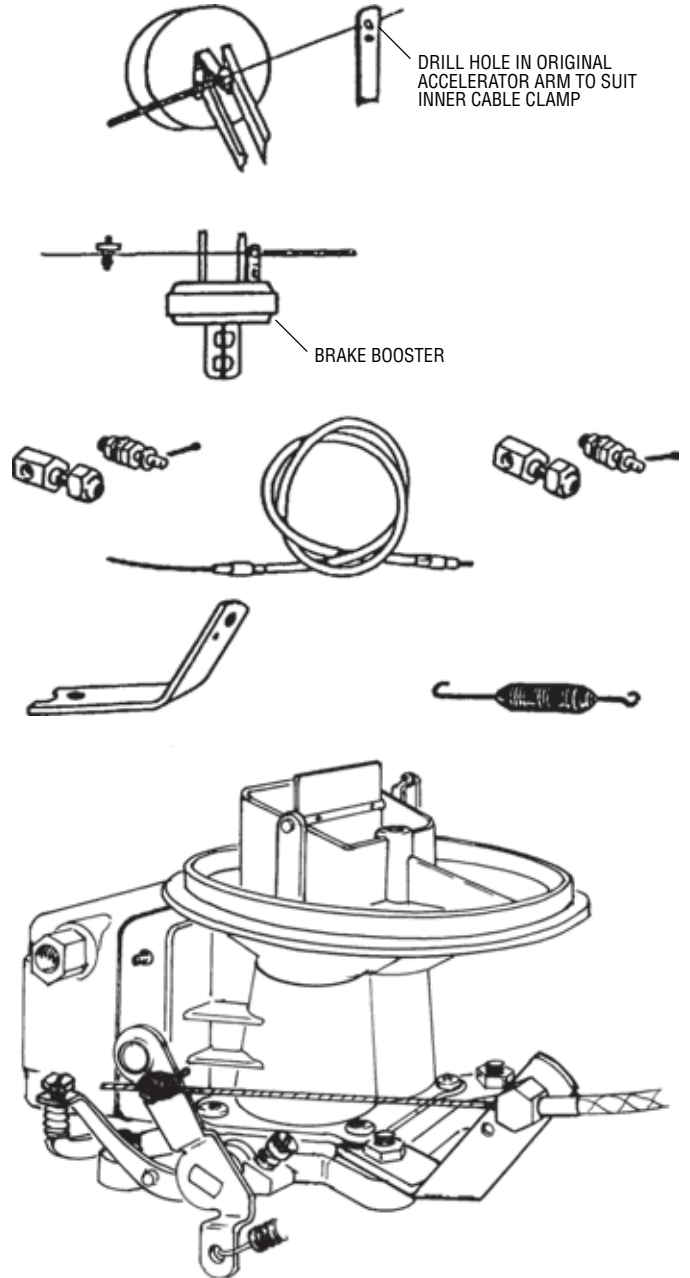

**42-37**

**Cable linkage kit**

to suit LC-LJ Torana 6 cylinder fitted with triple side draft Weber carburettors

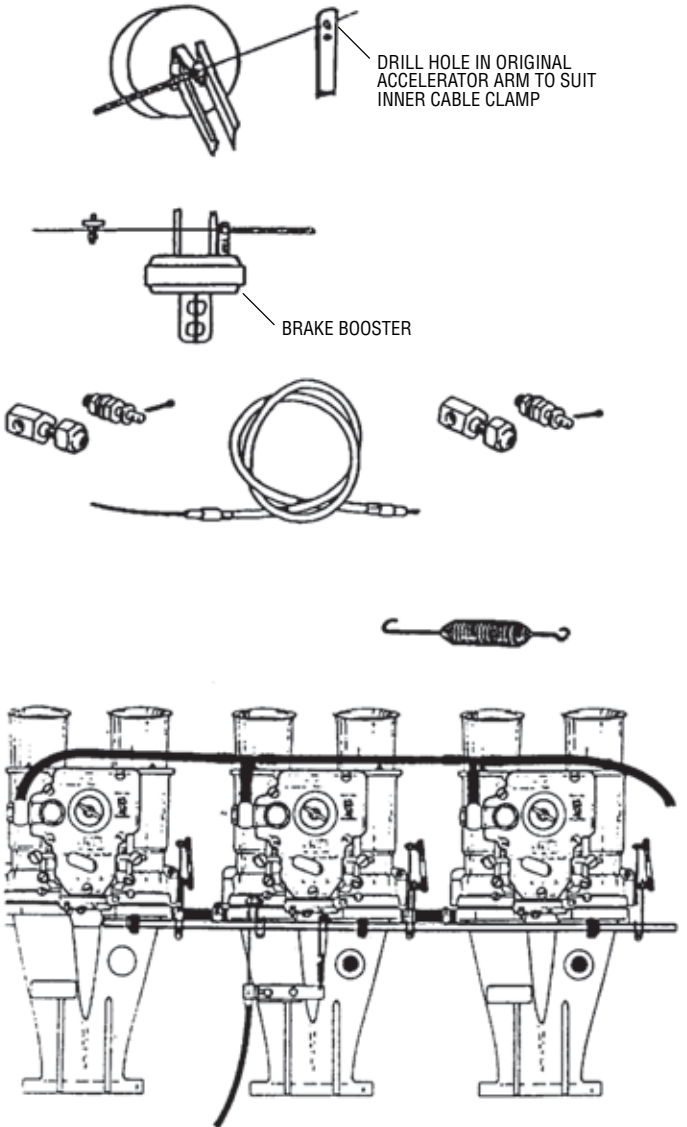
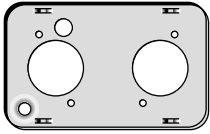
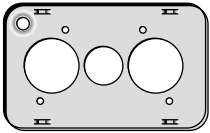

Photo by Jon Van Daal



Suits  
 • Weber DCOE  
 • Dellorto DHLA  
 • Solex ADDH  
 Rectangular type only 170mm x 105mm



Suits  
 • Weber IDF  
 • Dellorto DRLA  
 Rectangular type only 170mm x 105mm

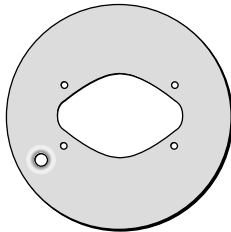
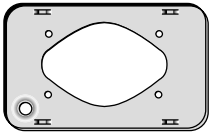

Suits  
 • Weber DFV, DFM, DHS, DFD, DIR  
 • Holley 5200 2bbl downdraught  
 9" (228mm) dia or 170mm x 105mm rectangular type

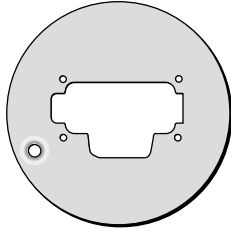
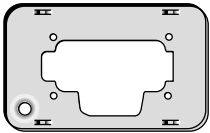

Suits  
 • Weber 32-36 DGV, DGAV, DGMS, DGAS, DGAR 2bbl  
 9" (228mm) dia or 170mm x 105mm rectangular type

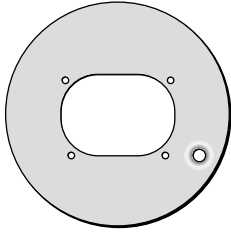
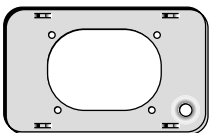

Suits  
 • Weber ADF, ADM, ADFA downdraught  
 • Solex EIE  
 9" (228mm) dia or 170mm x 105mm rectangular type

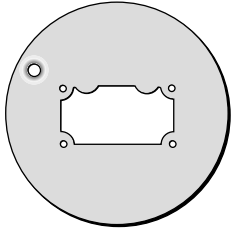
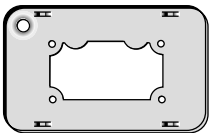

Suits  
 • Weber DCD, DAS, DCHD, DCHE, DCS 2bbl downdraught  
 9" (228mm) dia or 170mm x 105mm rectangular type

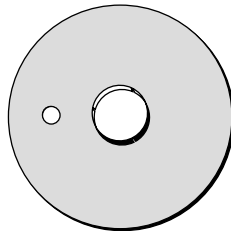
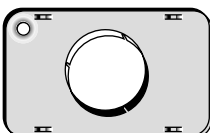

Suits  
 • Holley 2&4bbl (5 1/8" dia throat) 6 3/8" (162mm) & 9" (228mm) dia  
 • Holden Stromberg (2 5/16" throat) 6 3/8" (162mm) & 9" (228mm) dia  
 • Holden Stromberg (2 5/8" throat) 9" (228mm) dia only  
 • Holden 4cyl Gemini (Isuzu motor), Datsun 1600, 180B, 200B, 510, 610, 2000, 2300, 240K, 260C, 280C (80mm dia. throat) rectangular type only 170mm x 105mm

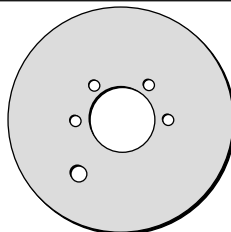

Suits  
 • 1 1/4" SU  
 • 1 1/2" SU  
 • 1 3/4" SU  
 5 1/2" (140mm) dia

**Note**  
 Rectangular type air filters are stainless steel and are available in 2 heights: 55mm and 75mm





**16-204**  
**16-205**  
**16-206**

**6 3/8in (162mm) dia x 50mm high Chrome Air filters**

**16-204** To suit 2 5/16in Stromberg Carb  
*Note: Not to be fitted to Ford Escort engines as the vibrations from these engines cause air cleaner base to break.*

**16-205** To suit 2 5/8in WW Stromberg Carburettors

**16-206** To suit 5 1/8in neck 2bbl & 4bbl Holley Carburettor



**16-213**

**13 1/2in (343mm) x 62mm high Chrome Air Filters**

5 1/8" neck 2bbl & 4bbl Holley Carburettors



**16-224**

**14in (356mm) dia Chrome Air Filters**

125mm high suits 5 1/8in neck 2bbl & 4bbl Holley Carburettors

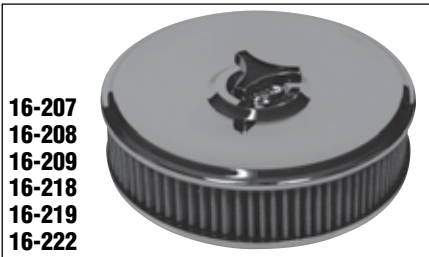

**16-207**  
**16-208**  
**16-209**  
**16-218**  
**16-219**  
**16-222**

**9in (228mm) dia x 55mm high chrome Air filters**

**16-207** 2 5/16in Stromberg Carburettors

**16-208** 2 5/8in WW Stromberg Carburettors

**16-209** 55mm high suits 5 1/8in neck 2bbl & 4bbl Carburettors

**16-218** 180cfm 2 bbl Holley Carburettors

**16-219** DGV DGAV DCD etc 2bbl Weber Carburettors

**16-222** ADM/ADF 2bbl Weber Carburettors



**16-214**

**14in (356mm) dia Chrome Air Filters**

55mm high suits 5 1/8in neck 2bbl & 4bbl Holley Carburettors



**16-225**

**14in (356mm) dia Chrome Air Filters**

150mm high suits 5 1/8in neck 2bbl & 4bbl Holley Carburettors



**16-211**

**9in (228mm) dia chrome Air filters**

100mm high suits 5 1/8in neck 2bbl & 4bbl Carburettors



**16-215**

**14in (356mm) dia Chrome Air Filters**

100mm high suits 5 1/8in neck 2bbl & 4bbl Holley Carburettors



**16-251**

**Performance Air Filter 14in (356mm) dia Ball Milled Billet Style alloy top and deep recessed base**

70mm high suits 5 1/8in neck 2bbl & 4bbl Holley Carburettors



**16-212**

**9in (228mm) dia chrome Air filters**

125mm high suits 5 1/8in neck 2bbl & 4bbl Carburettors



**16-217**

**14in (356mm) dia Chrome Air Filters**

70mm high suits 5 1/8in neck 2bbl & 4bbl Holley Carburettors

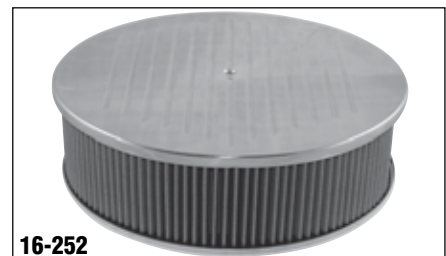

**16-252**

**Performance Air Filter 14in (356mm) dia Ball Milled Billet Style alloy top and deep recessed base**

100mm high suits 5 1/8in neck 2bbl & 4bbl Holley Carburettors



**16-253**

**Performance Air Filter 14in (356mm) dia Ball Milled Billet Style alloy top and deep recessed base**

63mm high suits 5 1/8in neck 2bbl & 4bbl Holley Carburettors



**16-254**

**Performance Air Filter 14in (356mm) dia Flamed Billet Style alloy top and deep recessed base**

70mm high suits 5 1/8in neck 2bbl & 4bbl Holley Carburettors



**16-255**

**Performance Air Filter 14in (356mm) dia Flamed Billet Style alloy top and deep recessed base**

100mm high suits 5 1/8in neck 2bbl & 4bbl Holley Carburettors



**16-258**

**Performance Air Filter 14in (356mm) dia Flamed Billet Style alloy top and deep recessed base**

63mm high suits 5 1/8in neck 2bbl & 4bbl Holley Carburettors



**16-241  
16-242  
16-243  
16-244  
16-245  
16-246  
16-248  
16-249**

**170mm (L) x 105mm (W) x 55mm (H) Stainless steel Rectangular Style Air Filters**

**16-241** DFV DFM DHS DFD DIR Weber & 180cfm Holley Carb model #5200

**16-242** DGV DGAV DGAS DGMS DGAR Weber

**16-243** 40mm DCOE Weber DHLA Dellorto ADDH Solex

**16-244** IDF Wever DRLA Dellorto

**16-245** 45mm DCOE Weber DHLA Dellorto ADDH Solex

**16-246** ADF ADM ADFA Weber EIE Solex

**16-248** 80mm neck Holden Gemini Datsun 1600 etc

**16-249** Supplied complete with blank base for customer DIY

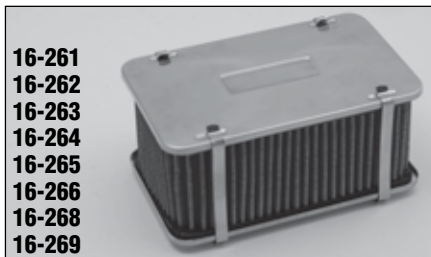

**16-261  
16-262  
16-263  
16-264  
16-265  
16-266  
16-268  
16-269**

**170mm (L) x 105mm (W) x 75mm (H) Stainless steel Rectangular Style Air Filters**

**16-261** DFV DFM DHS DFD DIR Weber & 180cfm Holley Carb model #5200

**16-262** DGV DGAV DGAS DGMS DGAR Weber

**16-263** 40mm DCOE Weber DHLA Dellorto ADDH Solex

**16-264** IDF Wever DRLA Dellorto

**16-265** 45mm DCOE Weber DHLA Dellorto ADDH Solex

**16-266** ADF ADM ADFA Weber EIE Solex

**16-268** 80mm neck Holden Gemini Datsun 1600 etc

**16-269** Supplied complete with blank base for customer DIY



**16-272  
16-275**

**Performance Air Filter 12in Oval Billet Style alloy**

100mm high suits 5 1/8in neck 2bbl & 4bbl Holley Carburettors

**16-272** Ball milled top

**16-275** Flamed top



**16-273  
16-276**

**Performance Air Filter 12in Oval Billet Style alloy**

125mm high suits 5 1/8in neck 2bbl & 4bbl Holley Carburettors

**16-273** Ball milled top

**16-276** Flamed top



**16-277**

**Performance Air Filter 14in (356mm) dia Ball Milled Billet Style alloy top and deep recessed base**

125mm high suits 5 1/8in neck 2bbl & 4bbl Holley Carburettors

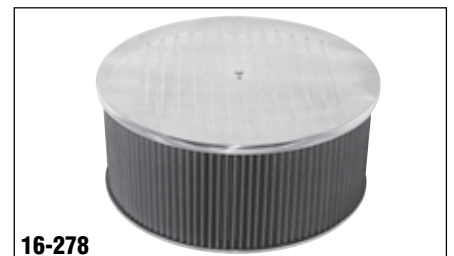

**16-278**

**Performance Air Filter 14in (356mm) dia Ball Milled Billet Style alloy top and deep recessed base**

150mm high suits 5 1/8in neck 2bbl & 4bbl Holley Carburettors



**16-279**

**Performance Air Filter 14in (356mm) dia Flamed Billet Style alloy top and deep recessed base**  
125mm high suits 5 1/8in neck 2bbl & 4bbl Holley Carburettors

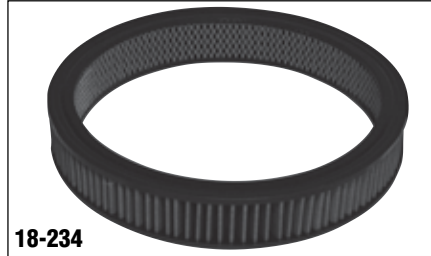

**18-234**

**Cotton Element 13 1/2in (343mm) dia x 55mm high**



**18-244**

**Cotton Element 14in (350mm) dia 2 3/4in (70mm) High**



**16-280**

**Performance Air Filter 14in (356mm) dia Flamed Billet Style alloy top and deep recessed base**  
150mm high suits 5 1/8in neck 2bbl & 4bbl Holley Carburettors

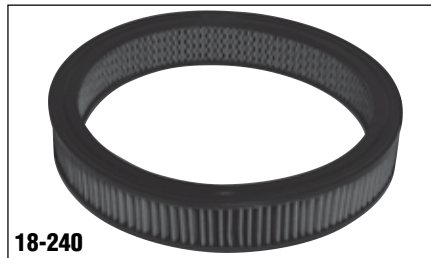

**18-240**

**Cotton Element 14in (350mm) dia 2in (55mm) High**

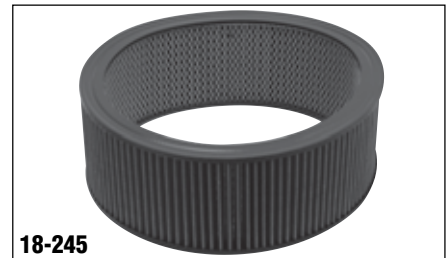

**18-245**

**Cotton Element 14in (350mm) dia 5in (125mm) High**

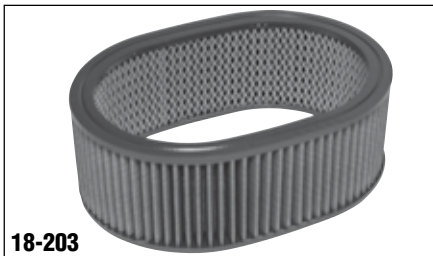

**18-203**

**Cotton Element Oval 290mm x 220mm 4in (100mm) High**

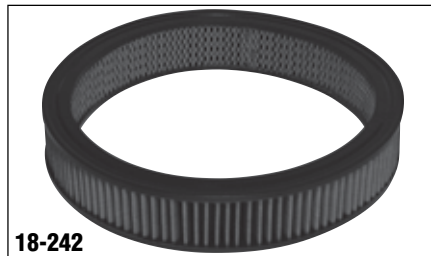

**18-242**

**Cotton Element 14in (350mm) dia 2 1/2in (62mm) High**

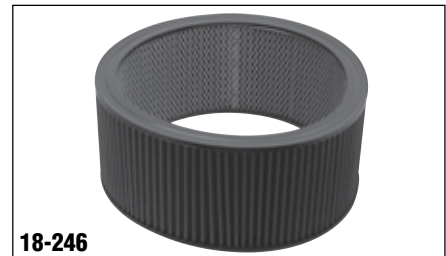

**18-246**

**Cotton Element 14in (350mm) dia 6in (150mm) High**

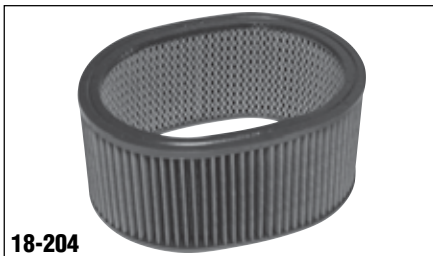

**18-204**

**Cotton Element Oval 290mm x 220mm 5in (125mm) High**



**18-243**

**Cotton Element 14in (350mm) dia 4in (100mm) High**

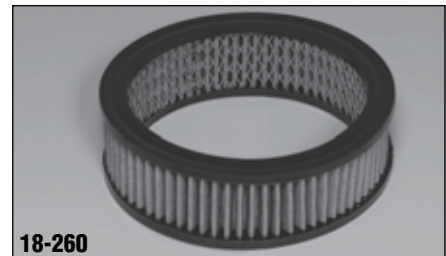

**18-260**

**Cotton Element 160mm dia 2in (50mm) high**





**18-255**

**Cotton Element Rectangular 170mm x 105mm**  
55mm High

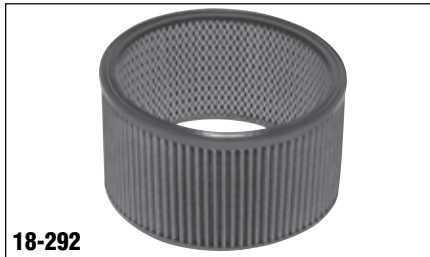

**18-292**

**Cotton Element 9in (229mm) dia**  
5in (125mm) High



**18-275**

**Cotton Element Rectangular 170mm x 105mm**  
75mm High

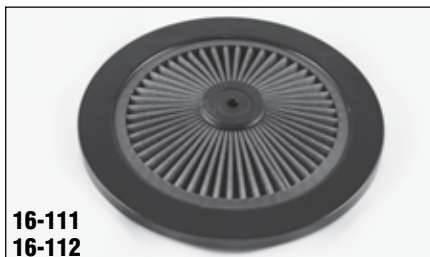

**16-111**

**16-112**

**9" Hi-flow cotton filtered air filter top**  
**16-111** Black  
**16-112** Chrome

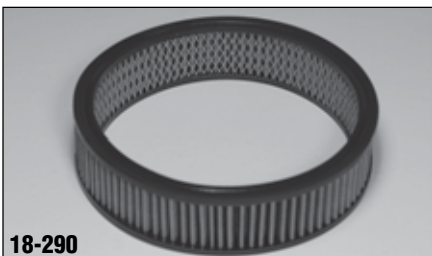

**18-290**

**Cotton Element 9in (229mm) dia**  
55mm High



**16-113**

**16-114**

**14" Hi-flow cotton filtered air filter top**  
**16-113** Black  
**16-114** Chrome

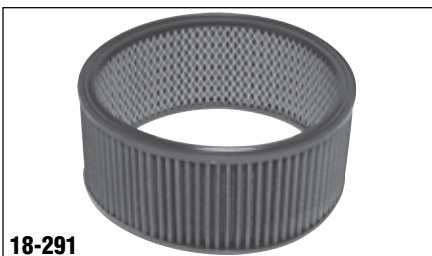

**18-291**

**Cotton Element 9in (229mm) dia**  
4in (100mm) High



**H222-1**

**Cone Filter**  
BA Ford V8 Cone type Filter

Make	Model	Part number
Ford	Falcon EF, EL, AU 6cyl, Falcon EB, ED, EF, EL, AU V8	18-491
	Ford BA-BF 6cyl & V8 (except BA XR8)	18-1357
	FG Falcon 6cyl, 8cyl	18-1582
Holden	Commodore VL 1986-88 6cyl. 3.0L, Commodore VN, VPVR, VS 1988-97 V6 3.8L Commodore VN, VP, VR, VS 1988-97 V8 5.0L, Statesman, Caprice, Senator VQ-VS 1990-97 V6 3.8L incl. Supercharged models Statesman, Caprice, Senator VQ-VS 1990-97 V8 5.0L HSV Grange WH, WHII 7/99-02 V6 3.8L supercharged & V8 5.0 & 5.7L HSV Senator VR 8-93 – 5/95 V8 5.0 & 5.7L HSV VS-VX 4/95-02 V6 3.8L supercharged	18-360
	Commodore VT-VZ 1997-01 6cyl 3.8L, Commodore VT-VZ 1997-01 V8 5.0 & 5.7L	18-1358
	Commodore VE 6cyl, 8cyl	18-2919
Nissan/Datsun	200SX 10/94-97 4cyl. 2.0L Turbo, 280C 3/83-84 6cyl. 2.8L 300C 1984-87 VG30 V6 3.0L SOHC, 300Z 1988-89 V6 3.0L Bluebird SSS series I&II 10/93-9/97 4cyl. 2.4L, Exa 2/87-10/91 KN13 1.6 & 1.8L Maxima J30 5/90-11/99 VG30 V6 3.0L, NX, NX-R Coupe 10/91-5/95 SR20 4cyl. 2.0L Navara D21 1/92-98 Z24, VG30 4cyl & V6 2.4L, 3.0L Pathfinder 9/92-98 VG30, VG33E V6 3.0L, 3.3L Patrol GQ 3/91-12/97 TB4.2 6cyl. 4.2L, Pintara, TRX 11/89-4/93 CA24, KA24 4cyl. 2.4L Pulsar N14, N15 10/91-00 GA16 SR20 4cyl. 1.6-2.0L, Serena C23 9/92-12/95 SR20 4cyl 2.0L Skyline R30, R31 3/81-5/91 L24, RB30 4cyl & v6 2.4L 3.0L	18-360
Subaru	Forrester 8/97-00 4cyl. 2.0L, impreza & WRX 4/93-2002 4cyl. 1.6-2.06L Liberty Series I&II 10/89-99 EJ22 4cyl. 2.2L, Outback 9/96-10/98 EJ25 4cyl 2.5L, SVX coupe 3/92/97 EG33 6cyl 3.3L	18-360
Toyota	Lexen 89-97 V6 3.8L	18-360



**18-360**
**Replacement Panel Filter**

Equivalent to Ryco No. A360, K&amp;N No. 33-2031-1.

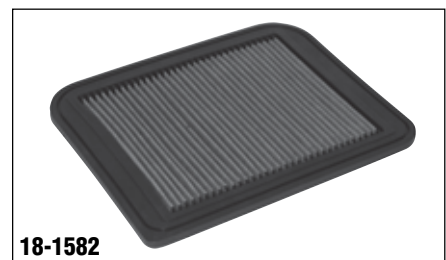
**18-1357**
**Cotton Panel Filter**

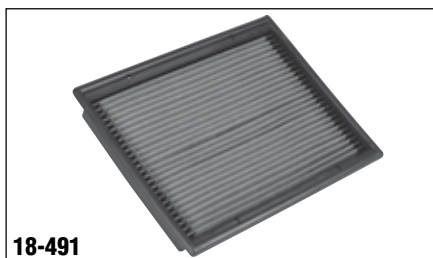
 Equivalent to Ryco A1575  
To suit BA Falcon

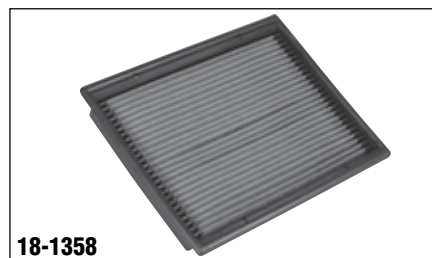
**18-1582**
**Cotton Panel Filter**

 Equivalent to Ryco A1582  
To suit FG Falcon

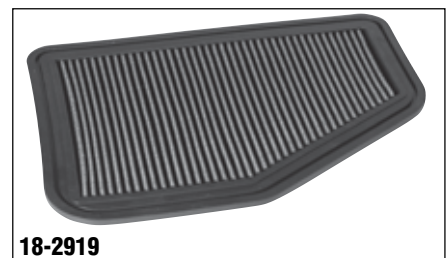
**18-491**
**Cotton Panel Filter**

 Equivalent to Ryco A491  
To suit Ford EF-EL, AU 6-8cyl

**18-1358**
**Cotton Panel Filter**

 Equivalent to Ryco A1575  
To suit VT Commodore on

**18-2919**
**Cotton Panel Filter**

 Equivalent to Ryco A1557  
To suit VE Commodore



**16-1**  
**16-11**  
**16-2**  
**16-26**  
**16-27**

**Performance Air Filter**

**5 1/2" (140mm) diameter x 55mm high**

- 16-1** To suit 1 1/4" SU Carburettor
- 16-11** To suit 1 1/2" SU Carburettor
- 16-2** To suit 1 3/4" SU Carburettor
- 16-26** To suit 3/4" Offset Base fit 1.25" SU Mini 850
- 16-27** To suit Offset 3/8" Base fit 1.5" SU MGB

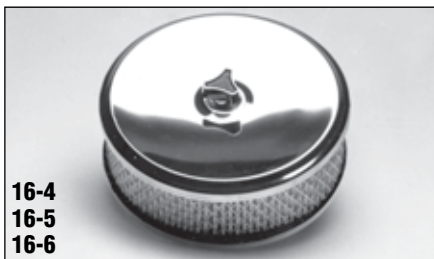

**16-4**  
**16-5**  
**16-6**

**Performance Air Filter**

**6 3/8" (162mm) diameter x 55mm high**

- 16-4** To suit 2 5/16" Stromberg Carb  
Note: Not to be fitted to Ford Escort Engines, as the Vibrations from these engines cause air cleaner base to break.
- 16-5** To suit 2 5/8" WW Stromberg Carb
- 16-6** To suit 5 1/8" neck 2bbl & 4bbl Holley Carburettor

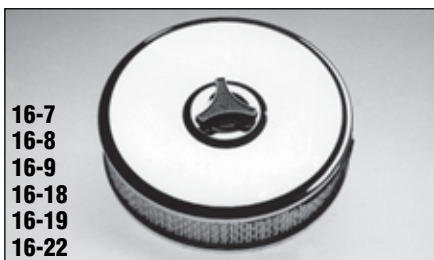

**16-7**  
**16-8**  
**16-9**  
**16-18**  
**16-19**  
**16-22**

**Performance Air Filter**

**9" (228mm) diameter x 55mm high**

- 16-7** To suit 2 5/16" Stromberg Carb  
Note: Not to be fitted to Ford Escort Engines, as the Vibrations from these engines cause air cleaner base to break.
- 16-8** To suit 2 5/8" WW Stromberg Carb
- 16-9** To suit 5 1/8" neck 2bbl & 4bbl Holley Carburettor
- 16-18** To suit 180cfm Holley 2bbl Carb
- 16-19** To suit DGV, DGAV, DCD etc 2bbl Weber Carburettors
- 16-22** To suit ADM/ADF Weber 2bbl Carb

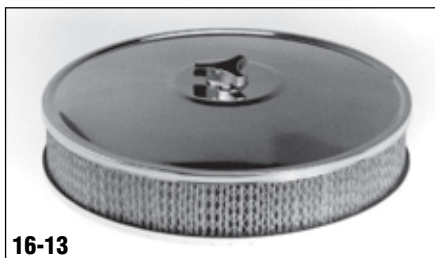

**16-13**

**Performance Air Filter**

**13 1/2" (343mm) diameter x 62mm high**

To suit 2bbl & 4bbl Holley with 5 1/8" neck



**16-14**  
**16-15**  
**16-17**

**Performance Air Filter 14" (356mm) dia**

- 16-14** Suit 2 & 4bbl Holley with 5 1/8" neck. 55mm high
- 16-15** Suit 2 & 4bbl Holley with 5 1/8" neck. 100mm high with 32mm (1 1/4") deep recessed base
- 16-17** Suit 2 & 4bbl Holley with 5 1/8" neck. 75mm high with 32mm (1 1/4") deep recessed base



**16-30C**  
**16-31C**

**Oval Shaped Cobra Style Filter**

**530mm long x 250mm wide x 50mm high**

**Black wrinkle alloy top**

- 16-30C** To suit Single 2 & 4bbl Holley Carbs with 5 1/8" neck
- 16-31C** To suit Dual 2 & 4bbl Holley Carbs with 5 1/8" neck



**16-32C**  
**16-33C**

**Oval Shaped Cobra Style Filter**

**530mm long x 250mm wide x 50mm high**

**Chrome top**

- 16-32C** To suit Single 2 & 4bbl Holley Carbs with 5 1/8" neck
- 16-33C** To suit Dual 2 & 4bbl Holley Carbs with 5 1/8" neck



**16-51**  
**16-52**  
**16-53**

**Performance Air Filter 14" (356mm) dia**

Billet style alloy top and deep recessed base

- 16-51** To suit 2bbl & 4bbl Holley with 5 1/8" neck. 75mm high.
- 16-52** To suit 2bbl & 4bbl Holley with 5 1/8" neck. 100mm high.
- 16-53** To suit 2bbl & 4bbl Holley with 5 1/8" neck. 62mm high.



**16-54**  
**16-55**  
**16-58**

**Performance Air Filter 14" (356mm) dia**

Flamed Billet style alloy top and deep recessed base

- 16-54** To suit 2bbl & 4bbl Holley with 5 1/8" neck. 75mm high.
- 16-55** To suit 2bbl & 4bbl Holley with 5 1/8" neck. 100mm high.
- 16-58** To suit 2bbl & 4bbl Holley with 5 1/8" neck. 62mm high.



**16-56**  
**16-57**

**Performance Air Filter 12in Oval Billet Style**

- 16-56** 12" x 2" Oval Ball Mill top
- 16-57** 12" x 2" Oval Flamed top





- 16-41
- 16-42
- 16-43
- 16-44
- 16-45
- 16-46
- 16-48
- 16-49

**Performance Air Filters Rectangular Style with Positive Locking Clips**

**170mm long x 105mm wide x 55mm high**

- 16-41** To suit Weber DFV, DFM, DHS, DFD, DIR & 180cfm Holley Model 5200
- 16-42** To suit Weber DGV, DGAV, DGAS, DGMS & DGAR
- 16-43** To suit Weber 40mm DCOE, Dellorto DHLA & Solex ADDH
- 16-44** To suit Weber IDF & Dellorto DRLA
- 16-45** To suit Weber 45mm DCOE, Dellorto DHLA & Solex ADDH
- 16-46** To suit Weber ADF, ADM, ADFA & Solex EIE
- 16-48** To suit 80mm throat Carburettor Holden Gemini, Datsun 1600 etc
- 16-49** Supplied complete with Blank Base. Customer may alter to suit carby

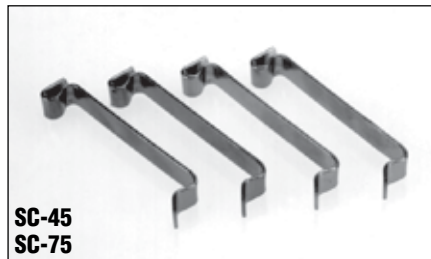

- SC-45**
- SC-75**

**Retaining Clips to suit Rectangular Sports Air Filters**

- SC-45 55mm long. Pack of 4
- SC-75 75mm long. Pack of 4



**16-519**

**Velocity Stack**

190mm high x 215mm top with 60mm high paper element to suit 5 1/8" neck carburettor 2 & 4bbl



**16-517**

**Marine Flame Arrestor**

140mm diameter x 65mm high to suit 5 1/8" neck carburettor 2 & 4bbl This filter has several layers of mesh to contain carburettor flameouts. A must for any marine application



- 16-61
- 16-62
- 16-63
- 16-64
- 16-65
- 16-66
- 16-68
- 16-69

**Performance Air Filters Rectangular Style with Positive Locking Clips**

**170mm long x 105mm wide x 75mm high**

- 16-61** To suit Weber DFV, DFM, DHS, DFD, DIR & 180cfm Holley Model 5200
- 16-62** To suit Weber DGV, DGAV, DGAS, DGMS & DGAR
- 16-63** To suit Weber 40mm DCOE, Dellorto DHLA & Solex ADDH
- 16-64** To suit Weber IDF & Dellorto DRLA
- 16-65** To suit Weber 45mm DCOE, Dellorto DHLA & Solex ADDH
- 16-66** To suit Weber ADF, ADM, ADFA & Solex EIE
- 16-68** To suit 80mm throat carb, Holden Gemini, Datsun 1600 etc
- 16-69** Air Cleaner with Blank Base

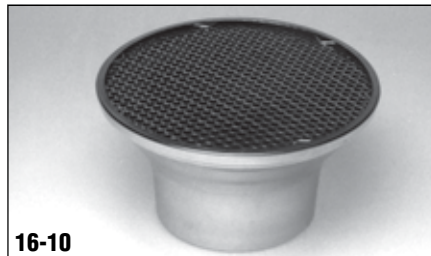

**16-10**

**Velocity Stack with Foam Filter**

Suit 2bbl & 4bbl Holley, etc. 5" high x 9" wide top with 5 1/8" neck

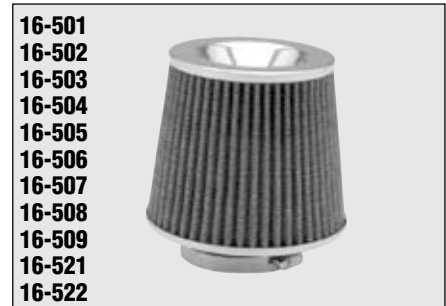

- 16-501**
- 16-502**
- 16-503**
- 16-504**
- 16-505**
- 16-506**
- 16-507**
- 16-508**
- 16-509**
- 16-521**
- 16-522**

**EFI Air Filter**

155mm base dia, 130mm height, 125mm end dia.

- 16-501** 65mm neck, chrome
- 16-502** 65mm neck, red
- 16-503** 65mm neck, blue
- 16-504** 76mm neck, chrome
- 16-505** 76mm neck, red
- 16-506** 76mm neck, blue
- 16-507** 114mm neck, chrome
- 16-508** 114mm neck, red
- 16-509** 114mm neck, blue
- 16-521** Carbon Fibre top 65mm Neck
- 16-522** Carbon Fibre top 76mm Neck



**16-518**

**Velocity Stack Open Style**

120mm high x 200mm top to suit 5 1/8" neck carburettor 2 & 4bbl



- 16-511**
- 16-512**

**EFI Filter Stainless Steel**

155mm dia x 110mm filter height

- 16-511** 76mm neck
- 16-512** 114mm neck



**21-25**

**Adaptor for Redline Air Force Air Filters**  
To suit Mitsubishi Lancer, Mirage, Magna 4cyl & 6cyl, Galant, Eclipse Turbo, Pajero. Use filter with 114mm hole size



**21-28**

**Adaptor for Redline Air Force Air Filters**  
To suit Mazda MX5, Astina, TX3, most BMW, Falcon XF EFI. Use filter with 76mm hole size

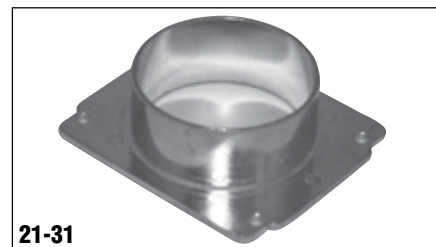

**21-31**

**Adaptor for Redline Air Force Air Filters**  
EFI air filter adaptor suit WRX '99 on

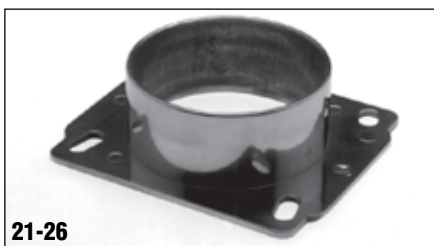

**21-26**

**Adaptor for Redline Air Force Air Filters**  
To suit Nissan Bluebird EFI, Pulsar N14, N15, SSS 2L, NXR, 200SX, EXA, KN13, Pulsar N14 1.6 NSX. Use filter with 76mm hole size

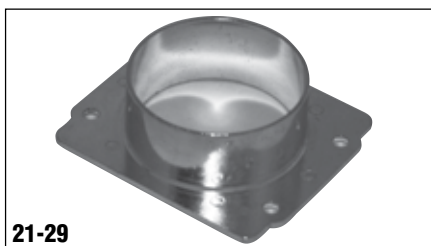

**21-29**

**Adaptor for Redline Air Force Air Filters**  
Suit Subaru & Nissan Patrol

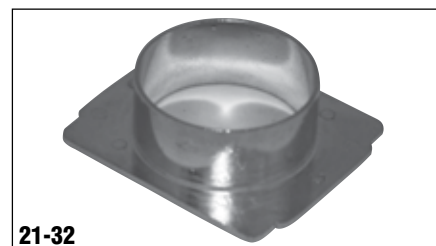

**21-32**

**Adaptor for Redline Air Force Air Filters**  
Blank Air Filter Pod Adaptor 76mm neck

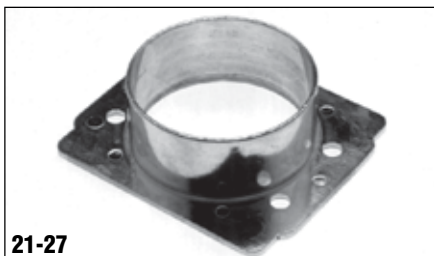

**21-27**

**Adaptor for Redline Air Force Air Filters**  
To suit Nissan Skyline 2.4L and RB30, Z18, FJ20, Z30 engines, Toyota Celica, Supra, Cressida, VL Commodore with RB30 Nissan engine, BMW 318-I E30, E36 Opal, Corsa, VW Golf, Audi A3, A4, Camry 88-91. Use filter with 76mm hole size

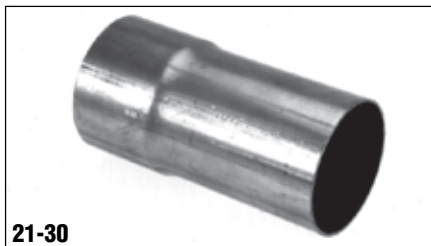

**21-30**

**Adaptor for Redline Air Force Air Filters**  
To suit Holden Commodore VR-on (1993-on) 6cyl & V8 models. Use filter with 76mm hole size

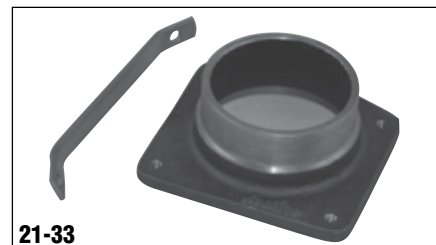

**21-33**

**Adaptor for Redline Air Force Air Filters**  
Pod adaptor suit AU Falcon 6 cylinder

**Note**

*Due to various model changes some EFI adaptors may not suit the application listed*



Photo by Jon Van Daal



**18-9**

**Paper Element** 217mm x 60mm  
Suits 16-519 Velocity Stack  
Suits Holden 6cyl, A24 Ryco equivalent



**18-90**  
**18-100**

**Paper Element**  
**18-90** 229mm x 55mm  
Suits 229mm (9") Air Cleaner  
**18-100** 254mm x 50mm  
Suits 254mm (10") Air Cleaner



**18-140**

**Paper Element** 350mm x 55mm  
Suits 355mm (14") Sports Air Cleaner



**18-10**  
**18-12**  
**18-25**

**Foam Element**  
**18-10** 228mm (9") Round  
suits 16-10 Air Filter  
**18-12** 305mm (12") Round  
suits 16-12 Air Filter  
**18-25** Triangular Style  
suits 16-25 Air Filter



**18-134**

**Paper Element** 343mm x 55mm  
Suits 343mm (13 1/2") Sports Air Cleaner

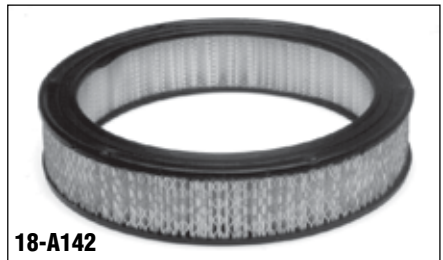

**18-A142**

**Paper Element** 285mm x 60mm  
Replacement element to suit Holden WB  
Statesman and Holden Commodore V8  
without EFI 1978-86, Calais V8 1986-88  
(except group A)



**18-40**

**Paper Element** 140mm x 55mm  
Suits 16-1, 16-2, 16-11 Sports Air Cleaner



**18-135**

**Paper Element** 343mm x 62mm  
Suits 343mm (13 1/2") Sports Air Cleaner



**18-142**

**Paper Element** 350mm x 62mm  
Suits 355mm (14") Sports Air Cleaner



**18-60**  
**18-65**

**Paper Element**  
Suits 162mm (6 3/8") Sports Air Cleaner  
**18-60** 160mm x 50mm  
**18-65** 160mm x 60mm



**18-136**

**Paper Element** 343mm x 100mm  
Suits 343mm (13 1/2") Sports Air Cleaner



**18-143**

**Paper Element** 350mm x 100mm  
Suits 355mm (14") Sports Air Cleaner





**18-144**

**Paper Element** 350mm x 70mm  
Suits 355mm (14") Sports Air Cleaner

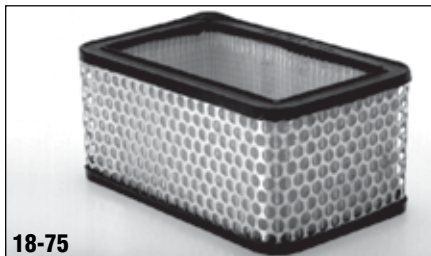

**18-75**

**Rectangular Paper Element**  
170mm x 105mm x 75mm  
Suits 16-61 to 16-68 Sports Air Cleaner



**18-149**

**Paper Element, Oval**  
300mm x 175mm x 50mm  
fits 16-34, 16-35 Sports Air Cleaner



**21-1**  
**21-2**

**El-Toro Wing Nut**  
**21-1** Small, with dual threads 1/4"unc & 5/16"unc  
**21-2** Large, with dual threads 1/4"unc & 5/16"unc

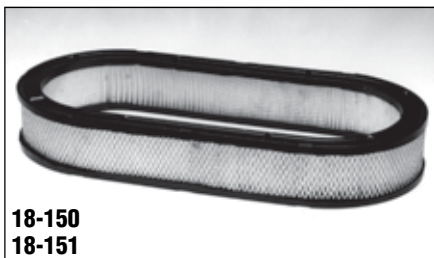

**18-150**  
**18-151**

**Element, High Oval Shape**  
**18-150** to suit Cobra style Air Cleaner 50mm (2")  
**18-151** to suit Cobra style Air Cleaner 76mm (3")



**21-4**

**Tri-Star Wing Nut**  
Large with dual threads 1/4"unc & 5/16"unc



**18-55**

**Rectangular Paper Element**  
170mm x 105mm x 55mm  
Suits 16-41 to 16-49 Sports Air Cleaner



**21-10**

**Air Cleaner Adaptor Ring**  
reduces 5 1/8" base to 2 5/8" base

**21-14**  
**Air Filter Adaptor**  
Reduces 5" base to 3" base

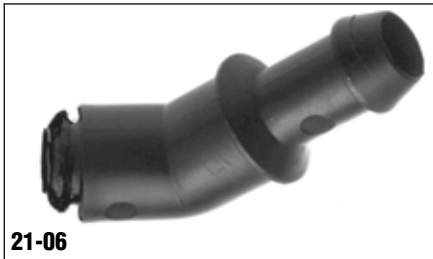

**21-06**  
**Air Cleaner Spout Push-in style**  
Fits 12.33mm hole eg 16-45.  
Warm base in hot water before pushing into hole

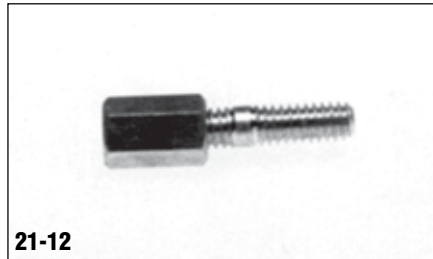

**21-12**  
**Air Cleaner Adaptor Stud 1/4"unc**  
Adaptor fits on top of the original carburettor air cleaner stud, eg Ford 6cyl & V8 etc. It acts as an extension to fit the wing nut.

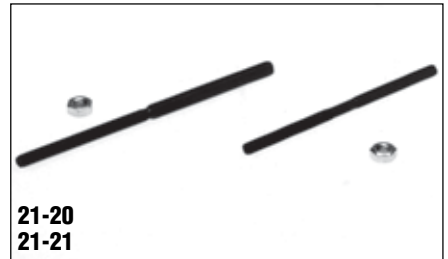

**21-20**  
**21-21**  
**Air Cleaner Carburettor stud**  
**21-20** 4 5/8" long with 1/4"unc thread  
**21-21** 5 1/2" long with 1/4"unc thread

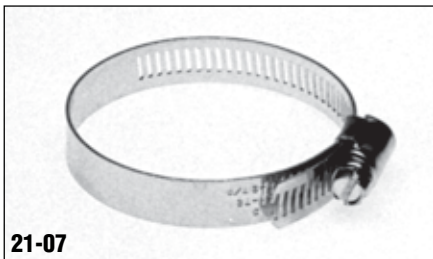

**21-07**  
**Air Cleaner Worm Drive Clamp**  
Suits 16-4, 16-5, 16-7 & 16-8 air cleaners

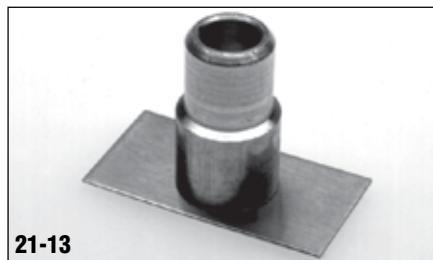

**21-13**  
**Air Cleaner Spout**  
Fits between top & base of 55mm air cleaner, takes 16mm or 19mm hose.  
Note: This special spout can be made to order in any height to fit between top and bottom of air cleaner lid and base.

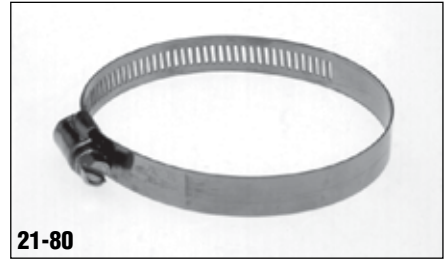

**21-80**  
**Air Cleaner Worm Drive Clamp**  
Suits 16-48 Air Cleaner



**21-08**  
**Air Cleaner Rubber Plugs**  
Suit 1/2" diameter holes. Pack of 8

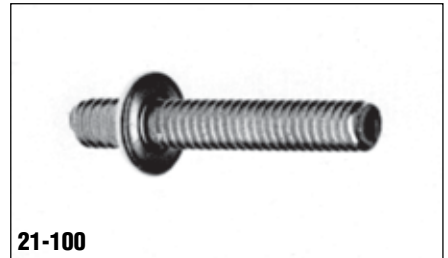

**21-100**  
**Air Cleaner Special Shoulder Stud**  
1 1/2" long with 1/4"unc thread



**21-09**  
**Air Filter Right Angle Spout**  
Suit 12mm (1/2") diameter hole.  
Barb fitting to suit 12mm (1/2") diameter hose

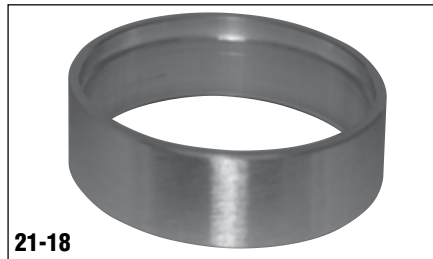

**21-18**  
**Air Cleaner spacer suit 5/8in neck**  
1in (25mm) spacer

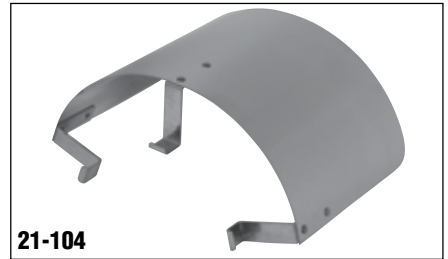

**21-104**  
**Stainless Steel Podfilter Heat Shield**  
Sheilds pod filter from heat sources



**21-11**  
**Air Cleaner Spout Kit bolt-on style**  
Fits hoses 17mm, 21mm, 25mm

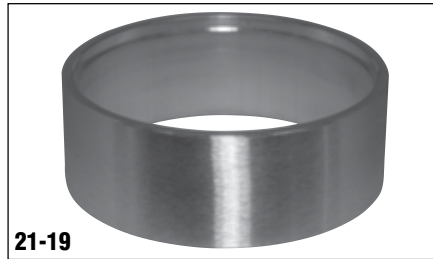

**21-19**  
**Air Cleaner spacer suit 5/8in neck**  
2in (50mm) spacer



**52-18**  
**52-19**  
**Air Cleaner Base Gasket**  
**52-18** Suits 16-18 air cleaner  
**52-19** Suits 16-19 air cleaner



**16-171**  
**16-172**  
**16-174**

**Ram Tube**

Bright silver anodised finish

**16-171** to suit 1 1/4" SU Carburettor

**16-172** to suit 1 1/2" SU Carburettor

**16-174** to suit 1 3/4" SU Carburettor



**16-83**

**Ram Tube**

to suit 40DCOE Weber, Dellorto & Solex Sidedraught Carburettors.

43mm long & spun aluminium blue in colour.



**16-173**

**Dash Pot Cover**

Bright silver anodised finish.

To suit 1 3/4" SU Carburettor



**16-86**

**Ram Tube**

to suit 45DCOE Weber, Dellorto & Solex Sidedraught Carburettors.

62mm long & spun aluminium silver in colour



**16-81**

**Ram Tube**

to suit 40DCOE Weber, Dellorto & Solex Sidedraught Carburettors.

43mm long & spun aluminium silver in colour



**16-87**

**Ram Tube**

to suit 45DCOE Weber, Dellorto & Solex Sidedraught Carburettors.

62mm long & spun aluminium red in colour



**16-82**

**Ram Tube**

to suit 40DCOE Weber, Dellorto & Solex Sidedraught Carburettors.

43mm long & spun aluminium red in colour



**16-88**

**Ram Tube**

to suit 45DCOE Weber, Dellorto & Solex Sidedraught Carburettors.

62mm long & spun aluminium blue in colour



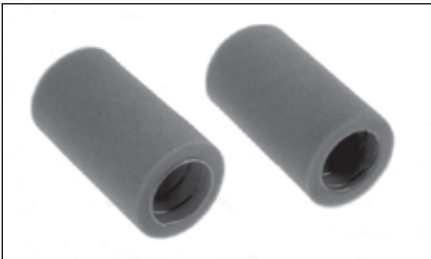

To suit carburettor & EFI flared Ram Tubes. Reusable foam Ram Air Sox are supplied oil coated with internal support spring and cable tie. Suitable for race, rally, off road and show cars.

To suit Weber DCOE 38,40,42 / SU 1.25", 1.5" / Hitachi (SU type) / Stromberg XU1 style, Dellorto 23, 35 & Solex 32,35

Part No.	Inside Dia.	Outside Dia.	Length	No. of Sox per Kit
RS403/1	53mm	83mm	100mm	1
RS403/2	53mm	83mm	100mm	2
RS403/4	53mm	83mm	100mm	4
RS603/1	53mm	83mm	150mm	1
RS603/2	53mm	83mm	150mm	2
RS603/4	53mm	83mm	150mm	4

To suit Weber DCOE 45,48,50 / SU 1.75", 2" / Dellorto 40,45,48 & Solex 40,44

Part No.	Inside Dia.	Outside Dia.	Length	No. of Sox per Kit
RS405/1	65mm	95mm	100mm	1
RS405/2	65mm	95mm	100mm	2
RS605/1	65mm	95mm	150mm	1
RS605/2	65mm	95mm	150mm	2
RS605/3	65mm	95mm	150mm	3
RS605/4	65mm	95mm	150mm	4

### Ram Air Sox 2nd Stage Filtering Covers

Available in red, yellow, green

Part No.	Suits Ram Air Sox Part Nos.
RS603/1STR	RS603/1 Single filtering cover
RS603/2STR	RS603/2 Double filtering cover (45 DCOE Weber)
RS605/1STR	RS605/1 Single filtering cover
RS605/2STR	RS605/2 Double filtering cover (45 DCOE Weber)

### Replacement Foam Elements for Lynx Ramflo Series Air Filters

Lynx Filter Series	Redline Replacement Filter Insert Part No.
300 Series	LNx 300
400 Series	LNx 400
600 Series	LNx 600
1000 Series	LNx1000

### Ram Air Pod Replacement Parts

Part No.	Description
FF01	Filter Fix – Filter Oil 250ml
FF02	Filter Fix – Filter Oil 500ml
FF03	Filter Fix – Filter Oil 1 litre

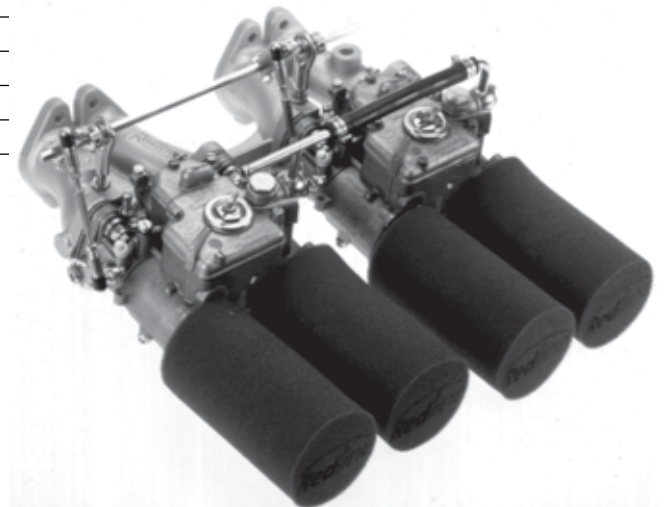



**24-130**

**Chrome Rocker Covers**

To Suit Chevy Small Block V8 engines. Low style covers, baffled. Chevy 283-350 V8 require 1/4"unc fasteners - 4 per cover. Use 26-100 Oil Cap grommet, 26-101 PCV grommet, 26-65 Oil Cap



**24-129**

**Chrome Rocker Covers**

To Suit Holden V8 Red, Blue & Black engines. Low style covers, baffled. 253-308 require 1/4"unc fasteners - 6 per cover. Use standard GMH grommets and twist on oil cap eg. P/No. 26-64 or 26-81



**24-145**

**Chrome Rocker Covers**

To Suit Ford Cleveland V8 engines. Hi-Style Covers, baffled. 302-351-400C require 1/4"unc fasteners - 8 per cover. Use 26-100 Oil Cap grommet, 26-101 PCV grommet, 26-65 Oil Cap



**24-131**

**Chrome Rocker Covers**

To Suit Chevy Small Block V8 engines. Hi-style covers, baffled. Chevy 283-350 V8 require 1/4"unc fasteners - 4 per cover. Use 26-100 Oil Cap grommet, 26-101 PCV grommet, 26-65 Oil Cap



**24-135**

**Chrome Rocker Covers**

To Suit Holden V8 Red, Blue & Black engines. Hi-style covers. Will not fit VB-VC Commodore if fitted with AC Delco air-conditioning compressor. 253-308 require 1/4"unc fasteners - 6 per cover. Use 26-100 Oil Cap grommet, 26-101 PCV grommet, 26-65 Oil Cap



**24-351**

**Chrome Rocker Covers**

To Suit Ford Cleveland V8 engines. Covers are baffled. Has 351 embossed on covers. 302-351-400C require 1/4"unc fasteners - 8 per cover. Use 26-100 Oil Cap grommet, 26-101 PCV grommet, 26-65 Oil Cap



**24-146**

**Chrome Rocker Covers**

To Suit Chevy, GM V6 engines. Covers are baffled. Chevy 200/229ci engines require 1/4"unc fasteners - 4 per cover. Use 26-100 Oil Cap grommet, 26-101 PCV grommet, 26-65 Oil Cap



**24-308**

**Chrome Rocker Covers**

To Suit Holden V8 Red, Blue & Black engines. Hi-style covers. Will not fit VB-VC Commodore if fitted with AC Delco air-conditioning compressor. Has 308 embossed on covers. 253-308 require 1/4"unc fasteners - 6 per cover. Use 26-100 Oil Cap grommet, 26-101 PCV grommet, 26-65 Oil Cap



**24-136**

**Chrome Rocker Covers**

To Suit Ford Windsor V8 engines. Covers are baffled. 289-302-351W require 1/4"unc fasteners - 6 per cover. Use 26-100 Oil Cap grommet, 26-101 PCV grommet, 26-65 Oil Cap



**24-137**

**Chrome Rocker Covers**

To Suit Chrysler Small Block V8 engines 273-360ci. Covers are baffled. Requires 1/4"unc fasteners - 5 per cover. Use 26-100 Oil Cap grommet, 26-101 PCV grommet, 26-65 Oil Cap



**24-133**

**Chrome Rocker Covers**

To Suit Ford Cleveland V8 engines. Covers are baffled. 302-351-400C require 1/4"unc fasteners - 8 per cover. Use 26-100 Oil Cap grommet, 26-101 PCV grommet, 26-65 Oil Cap



**24-134**

**Chrome Rocker Cover**

To suit Holden 6cyl engines 1964-78. Cover is baffled. 149-161-179-186-202 require 1/4"unc fasteners - 8 per cover. Use 26-100 Oil Cap grommet, 26-101 PCV grommet, 26-65 Oil Cap



**24-143**

**Chrome Rocker Cover**

To suit Holden 6cyl engines 1978 on.  
Cover is baffled.  
202 requires 1/4"unc fasteners - 8 per cover.  
Use 26-64 Oil Cap, use original rubber  
grommet for air cleaner breather and PCV  
fitting.

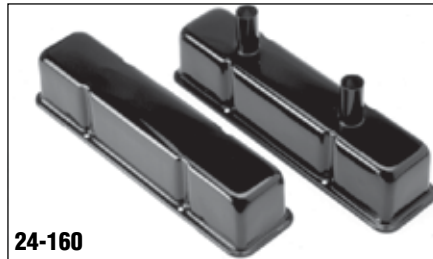

**24-160**

**Special black rocker covers**

To suit Chevy S/B V8 engine for Circle Track  
Application.  
Use Oil Cap Breathers part no. 26-522



**24-140**

**Chrome Side Plate Covers (pair)**

To suit Holden 1964-on 6cyl Red, Blue, Black  
engines.  
Requires 5/16"unc fasteners - 3 per cover.



**24-144**

**Chrome Rocker Cover**

To suit Chrysler slant 6cyl engines.  
170-225ci require 1/4"unc fasteners - 8 per  
cover. Use 26-100 Oil Cap grommet,  
26-102 PCV grommet, 26-65 Oil Cap



**24-161**

**Special black rocker covers**

To suit Ford 289-302W V8 engine for Circle  
Track Application.  
Use Oil Cap Breathers Part No. 26-522 for  
these covers.



**24-138**

**Chrome Rocker Cover**

To suit Ford Cast Iron & Alloy Head 6cyl  
engines. Cover is baffled.  
Requires 1/4"unc fasteners - 8 per cover.  
Use 26-100 Oil Cap grommet,  
26-101 PCV grommet, 26-65 Oil Cap



**24-132**

**Chrome Rocker Covers**

To suit Chevy Small Block V8 engines 305-  
350ci 1987 on



**24-141**

**Chrome Rocker Cover**

To suit Ford 6cyl engines 1960-76.  
Cover is baffled.  
Requires 1/4"unc fasteners - 7 per cover.  
Use 26-100 Oil Cap grommet,  
26-101 PCV grommet, 26-65 Oil Cap



**24-10  
24-11**

**Alloy Rocker Cover**

**24-10** To suit BLMC Mini 850-1275cc  
**24-11** To suit BMC 'B' Series (MGB) etc



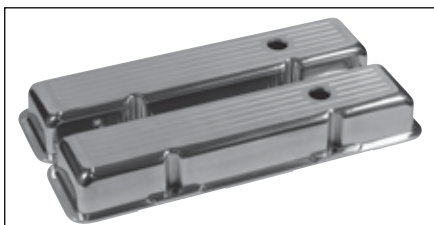

**24-8003**

**Alloy Rocker Covers**

To suit Chevy Small Block V8 engines. Low style Ball Milled covers. Baffled. Chevy 283-350 require 1/4in UNC fastners - 4 per cover.



**24-8014**

**Alloy Rocker Covers**

To suit Chevy Small Block V8 engines. Tall style Flamed covers. Baffled. Chevy 283-350 require 1/4in UNC fastners - 4 per cover.



**24-8034**

**Alloy Rocker Covers**

To Suit Chevy Small Block V8 Engines 305-350ci Centre bolt style 1987on. Tall Style Flamed covers

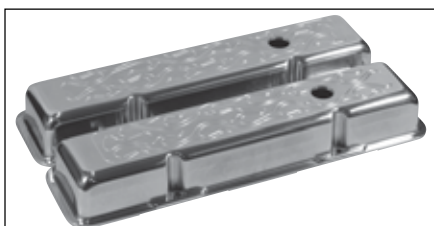

**24-8004**

**Alloy Rocker Covers**

To suit Chevy Small Block V8 engines. Low style Flamed covers. Baffled. Chevy 283-350 require 1/4in UNC fastners - 4 per cover.

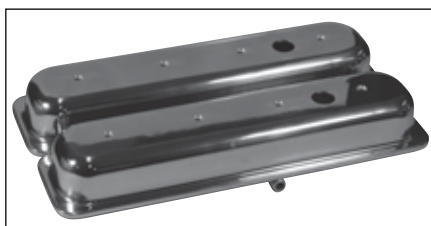

**24-8022**

**Alloy Rocker Covers**

To Suit Chevy Small Block V8 Engines 305-350ci Centre bolt style 1987on. Low Style plain covers

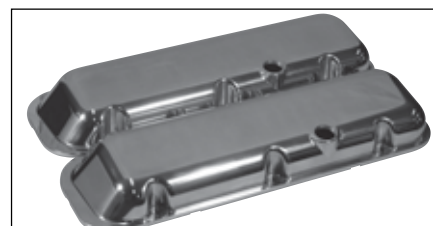

**24-8042**

**Alloy Rocker Covers**

To Suit Chevy Big Block V8 Engines. Low Style plain covers

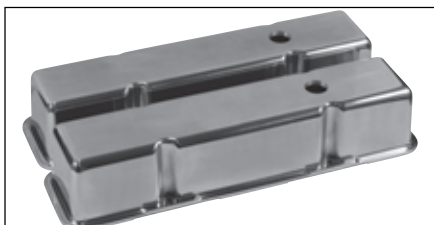

**24-8012**

**Alloy Rocker Covers**

To suit Chevy Small Block V8 engines. Tall style plain covers. Baffled. Chevy 283-350 require 1/4in UNC fastners - 4 per cover.



**24-8024**

**Alloy Rocker Covers**

To Suit Chevy Small Block V8 Engines 305-350ci Centre bolt style 1987on. Low Style Flamed covers



**24-8043**

**Alloy Rocker Covers**

To Suit Chevy Big Block V8 Engines. Low Style Ball Milled covers

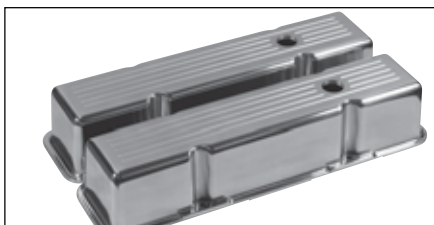

**24-8013**

**Alloy Rocker Covers**

To suit Chevy Small Block V8 engines. Tall style Ball Milled covers. Baffled. Chevy 283-350 require 1/4in UNC fastners - 4 per cover.



**24-8033**

**Alloy Rocker Covers**

To Suit Chevy Small Block V8 Engines 305-350ci Centre bolt style 1987on. Tall Style Ball Milled covers

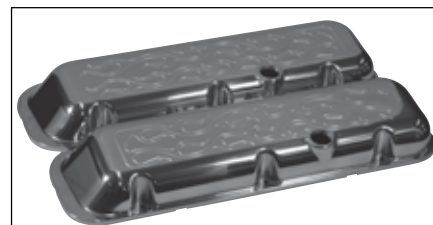

**24-8044**

**Alloy Rocker Covers**

To Suit Chevy Big Block V8 Engines. Low Style Flamed covers



**24-8052**

**Alloy Rocker Covers**

To Suit Chevy Big Block V8 Engines. Tall Style plain covers

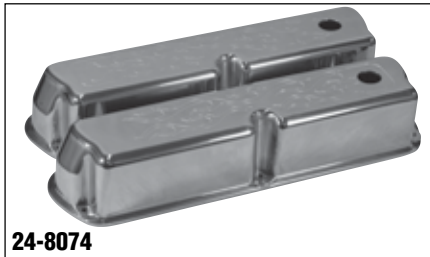

**24-8074**

**Alloy Rocker Covers**

To Suit Ford Windsor V8 Engines. Tall Style Flamed. 289-302-351 require 1/4in fasteners

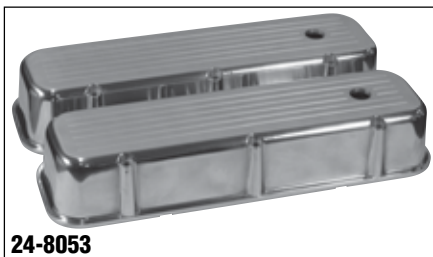

**24-8053**

**Alloy Rocker Covers**

To Suit Chevy Big Block V8 Engines. Tall Style Ball Milled covers



**26-99**  
**26-100**  
**26-101**  
**26-102**

**Rubber Grommet**

**26-99** Oil Cap rubber grommet open type.

**26-100** Oil cap rubber grommet, closed type. Base can be cut off to make this an open type grommet.

**26-101** PCV Rubber grommet, open type.

**26-102** PCV Rubber grommet, closed type.

Note: All above rubber grommets fit Redline rocker covers.

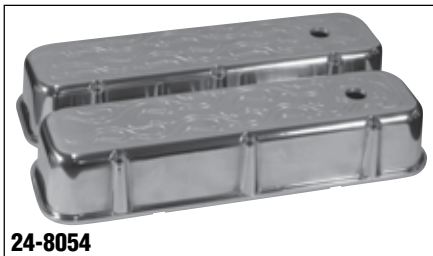

**24-8054**

**Alloy Rocker Covers**

To Suit Chevy Big Block V8 Engines. Tall Style Flamed covers



**24-8073**

**Alloy Rocker Covers**

To Suit Ford Windsor V8 Engines. Tall Style Ball Milled. 289-302-351 require 1/4in fasteners



**26-64**

**Chrome Oil Cap twist-on type**

Suits most standard & die-cast rocker covers



**26-69**

**Chrome Oil Cap push-in type**

With breather spout.  
Suits most Redline rocker covers



**26-82**

**Chrome Oil Cap push-in type**

With 1/2" (12mm) breather spout.  
Suits most Redline rocker covers



**26-65**

**Chrome Oil Cap push-in type**

Suits most Redline rocker covers



**26-79**

**Chrome oil cap push-in type**

No rubber grommet is required. Suits most Redline rocker covers.

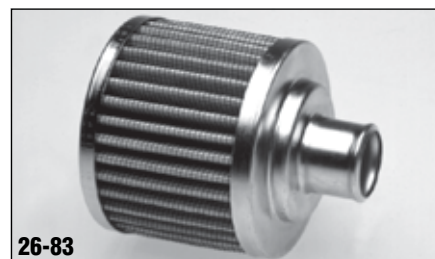

**26-83**

**Chrome Oil Cap push-in type**

Special high washable cotton element type.  
Suits most Redline rocker covers

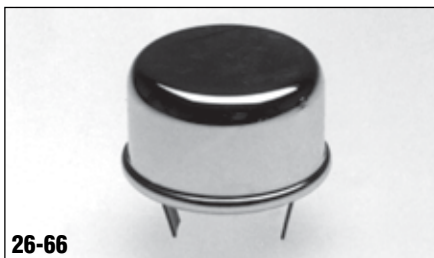

**26-66**

**Chrome Oil Cap push-in type**

With inside spring clips.  
Suits Ford 6cyl 1960-76, V8 Chevy & 253-308 with front oil filler tube



**26-80**

**Chrome Oil Cap push-in type**

Embossed with 'OIL' on cap.



**26-84**

**Chrome Oil Cap twist-on type**

Special high washable cotton element type.  
Suits 24-143 Redline Rocker Cover, most standard & die-cast rocker covers



**26-68**

**Chrome Oil Cap twist-on type**

With breather spout.  
Suits most standard & die-cast rocker covers



**26-81**

**Chrome Oil Cap twist-on type**

Non breather type.



**26-521**

**26-522**

**26-523**

**Chrome Oil Breather Cap Washable Cotton Element type**

65mm dia, 45mm height

**26-521** 15mm neck

**26-522** 35mm neck

**26-523** 38mm neck





**26-90**  
**Aluminium Billet Oil Cap push-in type (polished)**  
Suit chrome rocker covers

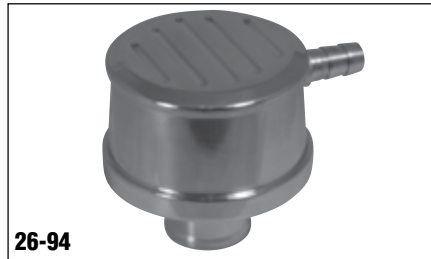

**26-94**  
**Billet PCV / Oil Cap Style**  
Ball milled polished finished. Uses oil cap grommet.



**26-122**  
**Grommet Covers**  
1inch id to suit Oil cap Grommets



**26-91**  
**Billet Oil Cap push in type**  
Plain polished finished



**26-95**  
**Billet PCV / Oil Cap Style**  
Flamed polished finished. Uses oil cap grommet.



**26-57**  
**Chrome Flip Top Wing Nuts**  
5/16 x 18tpi thread. Pack of 4



**26-92**  
**Billet Oil Cap push in type**  
Flamed polished finished



**26-96**  
**Billet PCV**  
Billet polished PCV. Uses PCV grommet



**26-58**  
**Chrome Acorn Nuts & Studs, 1/4" unc thread**  
Pack of 4



**26-93**  
**Billet PCV / Oil Cap Style**  
Plain polished finished. Uses oil cap grommet.



**26-121**  
**Grommet Covers**  
3/4in id to suit PCV Grommets



**26-60**  
**Chrome Flip Top Wing Nuts**  
1/4" x 20tpi thread. Pack of 4



**26-62**

**Chrome Fixed Head Wing Nuts**  
1/4" x 20tpi thread. Pack of 4.  
Designed to be used with alloy rocker covers or chrome steel covers using 26-70 or 26-72 Spreader Bars

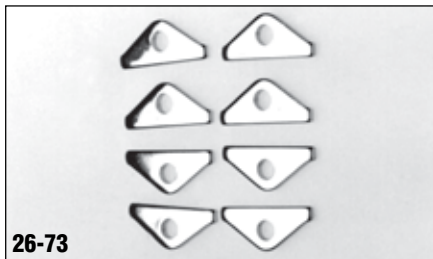

**26-73**

**Chrome Mini Hold Down Tabs**  
Suit Holden 6cyl or any rocker covers which use 1/4" fasteners.  
Spreads the load evenly and helps reduce distortion of the covers, improving gasket sealing.

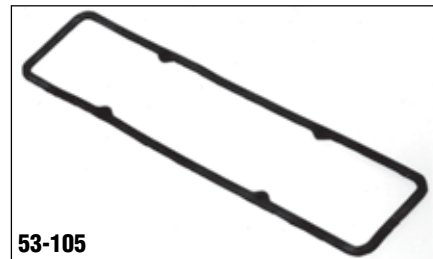

**53-105**

**Reusable Neoprene Rocker Cover Gasket**  
Fit V8 Chev 307-327-350



**26-63**

**Chrome 'T' Type Wing Nuts & Studs**  
1/4" x 20tpi thread. Pack of 4



**53-65**

**Reusable Neoprene Rocker Cover Gasket**  
Fit Holden 6cyl 1964-on

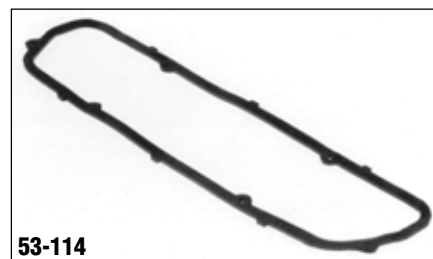

**53-114**

**Reusable Neoprene Rocker Cover Gasket**  
Fit V8 Holden 253-308 Red, Blue, Black engines

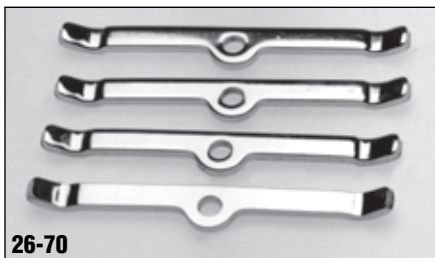

**26-70**

**Chrome Rocker Cover Spreader Bars**  
Suit S/B Chev. V8 engine. Pack of 4.  
Improves gasket sealing by spreading the load evenly on covers.

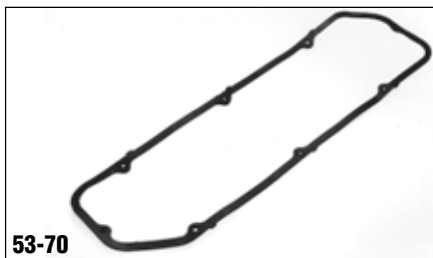

**53-70**

**Reusable Neoprene Rocker Cover Gasket**  
Fit Ford 6cyl X-flow 3.3 & 4.1



**53-351**

**Reusable Neoprene Rocker Cover Gasket**  
Fit V8 Ford 302-351C



**26-72**

**Chrome Rocker Cover Spreader Bars**  
Suit Holden 253-308 V8 engine. Pack of 6.  
Improves gasket sealing by spreading the load evenly on covers.

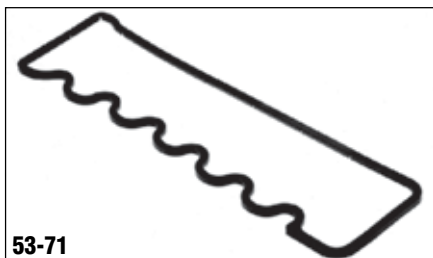

**53-71**

**Reusable Neoprene Rocker Cover Gasket**  
Fit Ford 6cyl X-flow EA, EB and early ED models

Thermostat housings are manufactured in diecast alloy material and are subject to corrosion. The thermostat housing becomes a sacrificial component similar to sacrificial anodes used in marine application.

Water used in a cooling system is there to provide heat transfer away from various components in the engine. Water whether plain or used in conjunction with corrosion inhibitors will still create a corrosive environment in the cooling system. To help reduce corrosion a good quality corrosion inhibition must be used in a closed circuit water cooled engine.

The corrosion inhibition level must be maintained when topping up the cooling system and periodically changed to help continue protection against scale formation and acid build up. Coolant used must meet or exceed AS2108.

It is therefore impossible to place a guarantee on the life of a thermostat housing.

Note when changing a thermostat housing it is important to check that the thermostat is functioning correctly (test in hot water) otherwise overheating of the thermostat housing and engine can occur.



**22-51-0**

**Billet Alloy Thermostat Housing 'O' ring style**

45 deg swivel to suit Chevy V8 283 - 350 S/B



**22-52-0**

**Billet Alloy Thermostat Housing 'O' ring style**

90 deg swivel to suit Chevy V8 283 - 350 S/B



**22-53-0**

**Billet Alloy Thermostat Housing 'O' ring style**

75 deg swivel to suit Chevy V8 283 - 350 S/B



**22-65-0**

**Chrome Thermostat Housing 'O' ring style**

To suit Holden Red 6cyl 1964-on



**22-66-0**

**Chrome Thermostat Housing 'O' ring style**

Angled

To suit Chevy V8 283-350 S/B

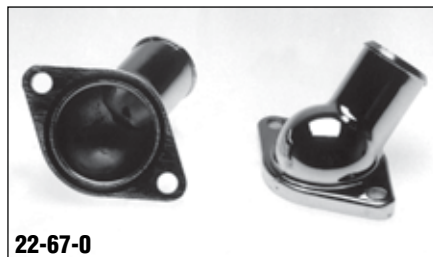

**22-67-0**

**Chrome Thermostat Housing 'O' ring style**

Straight

To suit Chevy V8 283-350 S/B



**22-68-0**

**Chrome Thermostat Housing 'O' ring style**

to suit Ford V8 Windsor 289-302



**22-69-0**

**Chrome Thermostat Housing 'O' ring style**

To suit Ford V8 Cleveland 302-351 up to XC 1978

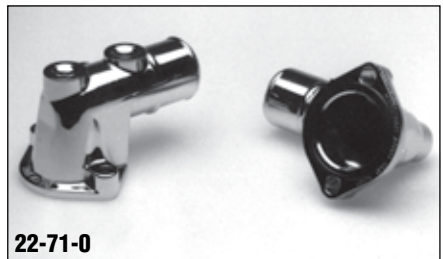

**22-71-0**

**Chrome Thermostat Housing 'O' ring style**

To suit Ford V8 Cleveland 302-351 1978-on



**22-72-0**

**Chrome Thermostat Housing 'O' ring style**

To suit Holden V8 253-308 with single heater hose outlet. 1968-1977



**22-73-0**

**Chrome Thermostat Housing 'O' ring style**

To suit Holden 253-308 1977-on with double heater hose outlet.



**22-74**

**Chrome Thermostat Housing Gasket only**

To suit Chrysler V8 273-360

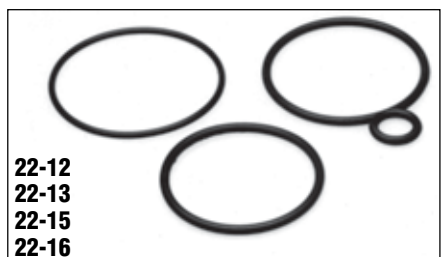

**22-12**

**22-13**

**22-15**

**22-16**

**Replacement 'O' rings to suit chrome thermostat housings**

**22-12** Suits 22-68-0 figure 8 type 'O' ring

**22-13** Suits 22-69-0, 22-71-0

**22-15** Suits 22-65-0, 22-66-0, 22-67-0

Late type thin ring

**22-16** Suits 22-72-0, 22-73-0

Late figure 8 type 'O' ring





**28-103**  
**28-104**

**Oil Pan**

To suit Holden 253-308 HQ to HZ, WB, Torana LH-LX-UC

**28-103** Chrome

**28-104** Plain



**28-110**  
**28-111**

**Oil Pan**

To suit Chevy V8 Small Block.

Dip Stick fits on passenger's side

**28-110** Chrome

**28-111** Plain

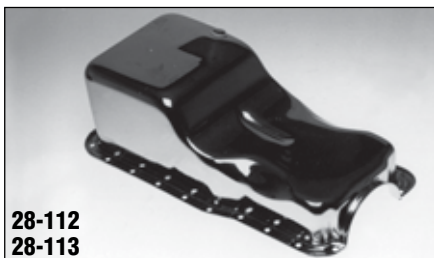

**28-112**  
**28-113**

**Oil Pan**

To suit Ford V8 Windsor 289-302 engine

Dip stick on driver's side

**28-112** Chrome

**28-113** Plain

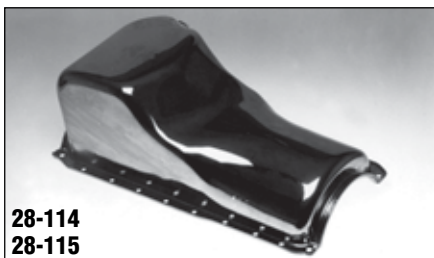

**28-114**  
**28-115**

**Oil Pan**

To suit Ford 302-351 Cleveland V8

**28-114** Chrome

**28-115** Plain



**28-118**

**Chrome Oil Pan**

Suit Ford 429-460



**28-119**

**Chrome Oil Pan**

Suit Chrysler 273-360 except 340



**28-120**  
**28-122**

**Plain Oil Pan**

To suit Ford V8 351 Windsor engine

**28-120** Chrome

**28-122** Plain

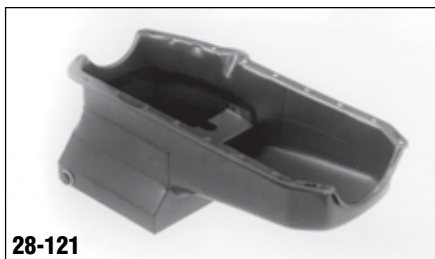

**28-121**

**Large Capacity Oil Pan**

6.2/3 litres, suits Chevy V8 Small Block.

Passenger side Dipstick. Orange in colour.

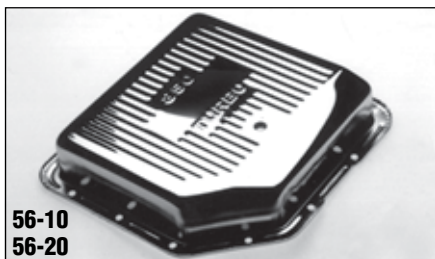

**56-10**  
**56-20**

**Chrome Transmission Oil Pan**

To suit Turbo 350 Automatic.

Drain plug supplied

**56-10** Standard

**56-20** Extra deep



**56-11**

**Chrome Transmission Oil Pan**

To suit C4 Automatic. Large capacity, finned base for cooling, drain plug.

Fits V8 models only, is NOT SUPPLIED with plug. Use P/No. 56-13 for 6cyl models.



**56-12**

**Chrome Transmission Oil Pan**

To suit C6 Automatic. Drain plug supplied



**56-21**  
**56-23**

**Chrome Transmission Oil Pan**

To suit Turbo 400 Automatic. Drain plug supplied

**56-21** Standard

**56-23** Extra deep



**56-22**

**Chrome Transmission Oil Pan**

To suit Powerglide Automatic. Drain plug supplied

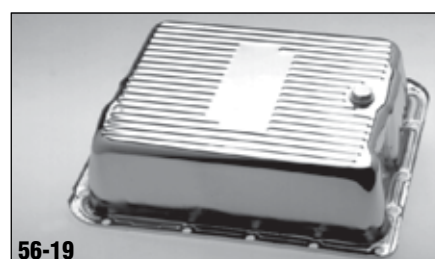

**56-19**

**Chrome Transmission Oil Pan**

With drain plug. Finned base for cooling.

Fits Turbo 700 automatic transmission (as used in Holdens).

Large capacity - 32mm (1 1/4") deeper than standard oil pan. Bracket must be used to hold up filter



**28-40**

**Chrome Radiator Cap Cover**

Locks onto cap with adjustable screw at both ends



**28-106**

**Chrome Timing Case Cover**

Suit Chevy Big Block V8 Engine



**28-162**  
**28-163**

**Flywheel Steel Dust Cover**

Suits Turbo 350 & 400 Auto in 253-308 Holden V8

**28-162** Black  
**28-163** Chrome



**28-41**

**Alloy Timing Case Cover**

Suit Chevy Small Block V8 Engine



**28-109**

**Chrome Oil Filter Cover**

Locks onto oil filter with adjustable screw



**28-42**

**Alloy Timing Case Cover**

Suit Chevy Big Block V8 Engine

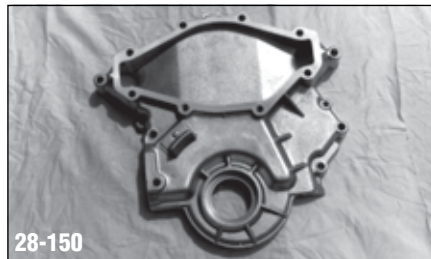

**28-150**

**Alloy Timing Case Cover**

Heavy Duty to suit 253/308 Holden V8



**28-105**

**Chrome Timing Case Cover**

Suit Chevy Small Block V8 Engine

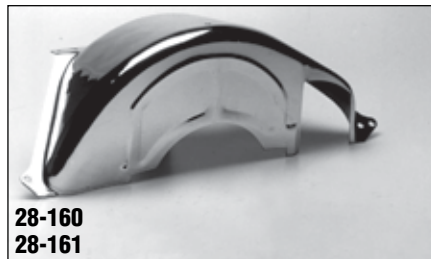

**28-160**  
**28-161**

**Flywheel Dust Cover**

Suits Turbo 350 & 400 Auto transmissions fitted to Small Block Chevy 283-400ci

**28-160** Black  
**28-161** Chrome



28-71

**Chrome Dipstick Handle Hooker Type**

Cut original dipstick to fit, insert into handle and lock down with grub screw supplied.



28-74

**Chrome Dipstick and Tube**

suit GM Turbo 400 Automatic

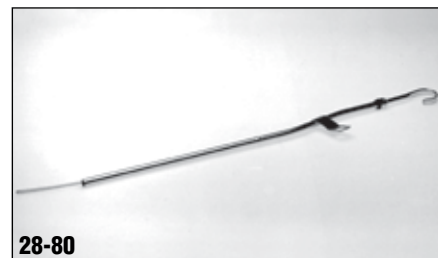

28-80

**Chrome Dipstick and Tube**

suit Ford Cleveland 302-351 V8



28-72

**Chrome Dipstick Handle, Dagger Type**

Cut original dipstick to fit, insert into handle and lock down with grub screw supplied.

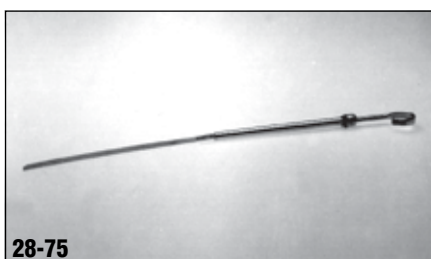

28-75

**Chrome Dipstick and Tube**

suit Holden 6cyl 1964-on

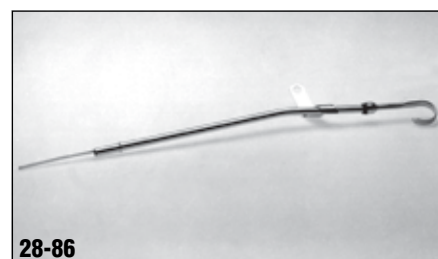

28-86

**Chrome Dipstick and Tube**

suit Holden 253-308 V8 1969-1984 (not Commodore)

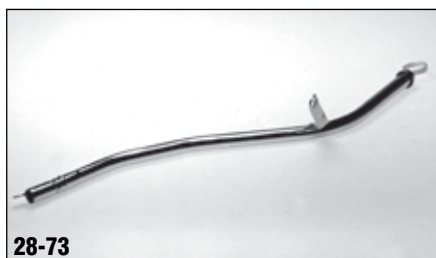

28-73

**Chrome Dipstick and Tube**

suit GM Turbo 350 Automatic

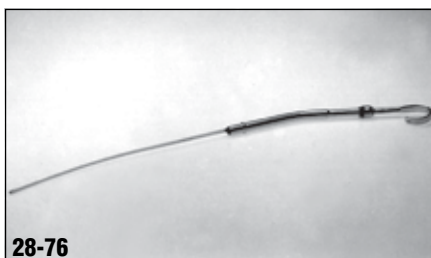

28-76

**Chrome Dipstick and Tube**

suit Chevy V8 Small Block Engine

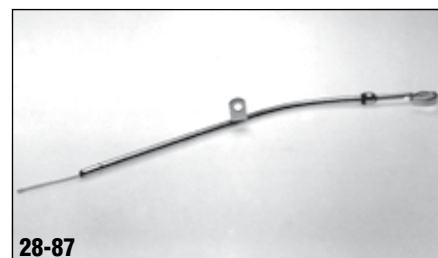

28-87

**Chrome Dipstick and Tube**

suit Holden 253-308 V8 1980-on Commodore

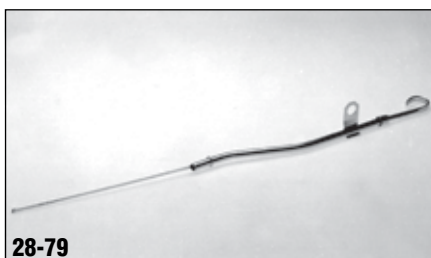

28-79

**Chrome Dipstick and Tube**

suit Ford Windsor 289-302 V8 1971-on



28-89

**Chrome Dipstick and Tube**

suit Chevy 1980-82 driver's side



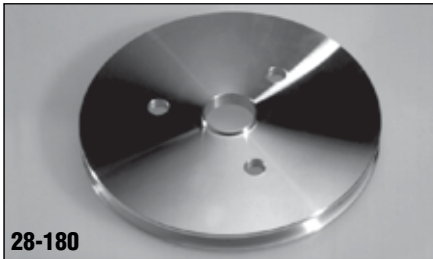

28-180

**Single Groove Lower Pulley**  
To suit S/B Chev. V8 with Short Water Pump

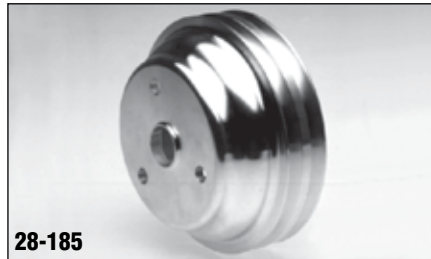

28-185

**Double Groove Lower Pulley**  
To suit S/B Chev. V8 with Long Water Pump

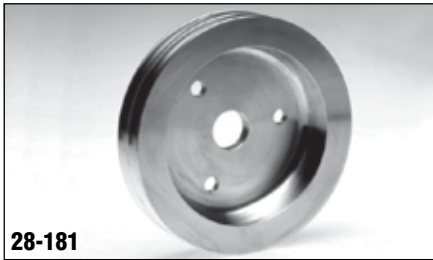

28-181

**Double Groove Lower Pulley**  
To suit S/B Chev. V8 with Short Water Pump

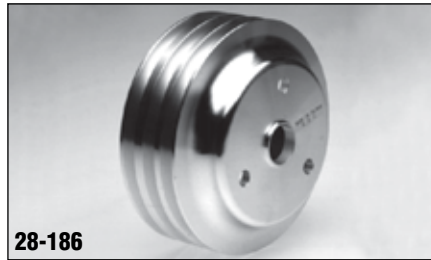

28-186

**Triple Groove Lower Pulley**  
To suit S/B Chev. V8 with Long Water Pump



28-182

**Single Groove Upper Pulley**  
To suit S/B Chev. V8 with Short Water Pump



28-187

**Single Groove Upper Pulley**  
To suit S/B Chev. V8 with Long Water Pump



28-183

**Double Groove Upper Pulley**  
To suit S/B Chev. V8 with Short Water Pump



28-188

**Double Groove Upper Pulley**  
To suit S/B Chev. V8 with Long Water Pump

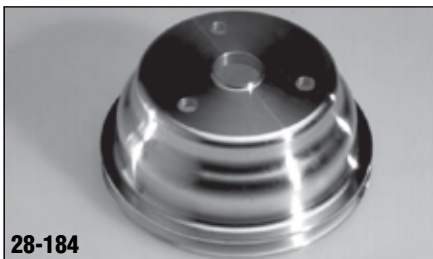

28-184

**Single Groove Lower Pulley**  
To suit S/B Chev. V8 with Long Water Pump



28-7

**Countersunk Socket Head Screws**  
Suit Redline Alloy Water Pump Pulleys  
for Small Block Chev



R-202  
R-308  
R351  
R-350S  
R-350L  
R-GEM

**Gilmer Drive**

- R-202** Suit Holden 6cyl EH-on.  
Use belt No. 322L-100
- R-308** Suit Holden V8 253-308 HQ-VB & LH Torana. Use belt No. 367L-150 or No. 390L-150
- R351** Suit Ford Cleveland & 289-302 Windsor V8 with 4-bolt pulley.  
Use belt No. 345L-150
- R-350S** Suit S/B Chevy 307-350 V8 with Short Water Pump. Use belt No. 390L-150 or No. 420L-150
- R-350L** Suit S/B Chevy 307-350 V8 with Long Water Pump. Use belt No. 390L-150 or No. 420L-150
- R-GEM** Suit Holden Gemini 1600 to 2 litre engines. Use belt No. 300L-100

**Note**

*In most cases with Chevy Small Block engines belt No. 390L-150 will fit.  
These Gilmer Kits will not fit vehicles fitted with air conditioning or power steering.*

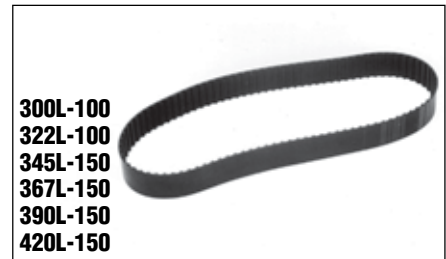

300L-100  
322L-100  
345L-150  
367L-150  
390L-150  
420L-150

**Gilmer Drive Belts**

- 300L-100** Suits Holden Gemini
- 322L-100** Suits Holden 6cyl EH-on
- 345L-150** Suits Ford 302-351 Cleveland & Windsor V8 with 4 Bolt Crank Pulley.
- 367L-150** Suits Holden LH Torana 253-308 V8
- 390L-150** Suits Most Small Block Chevy V8s
- 420L-150** Suits all other Small Block Chevy V8s

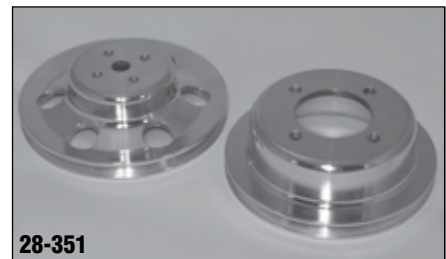

28-351

**Alloy crank/water pump pulley kit**  
Suit 302/351 Cleveland  
Also suits Windsor with 4 Bolt crank pulley



**12-8**  
**12-536**  
**12-9**  
**12-10**

**Inlet Manifold studs & nuts**

Set of 4

- 12-8** 5/16"unf x 1 1/4" long
- 12-536** 5/16"unf x 1 3/4" long suits DCOE Weber
- 12-9** 5/16"unf x 2 1/4" long
- 12-10** 5/16"unf x 3 1/4" long

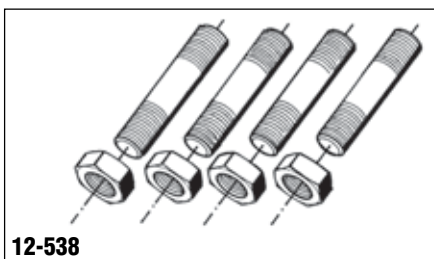

**12-538**

**Inlet Manifold studs & nuts**

3/8"w x 3/8"unf x 1 1/4" long

Suits Twin or Triple Stromberg Inlet Manifold  
Set of 4

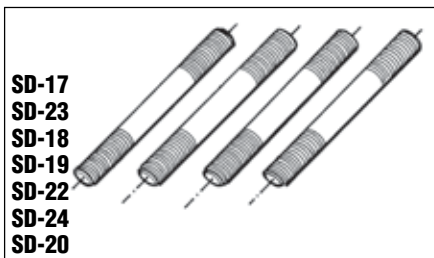

**SD-17**  
**SD-23**  
**SD-18**  
**SD-19**  
**SD-22**  
**SD-24**  
**SD-20**

**Manifold Stud**

- SD-17** 7mm x 8mm x 50mm long
- SD-23** 8mm x 8mm x 40mm long
- SD-18** 5/16"unf x 5/16"w x 1 1/4" long
- SD-19** 5/16"unf x 5/16"w x 2 1/4" long
- SD-22** 5/16"unf x 5/16"w x 3 1/4" long
- SD-24** 3/8"w x 3/8"unf x 1 1/4" long
- SD-20** 5/16"unf x 5/16"unf x 1 9/16" long to suit Uniballs Part Nos. 42-3088 & 42-3091



**SD-27**

**Manifold Stud**

3/8"w x 5/16"unf x 1 3/4" long

To suit manifold threaded 3/8"whit(unc).  
To fit Uniball Part Nos. 42-3089 and 42-3090

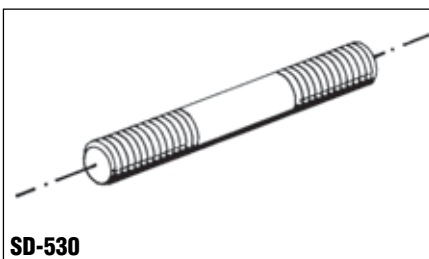

**SD-530**

**Manifold Stud**

5/16"unf x 5/16"w x 1 3/4" long

To suit Sidedraught DCOE Weber manifolds

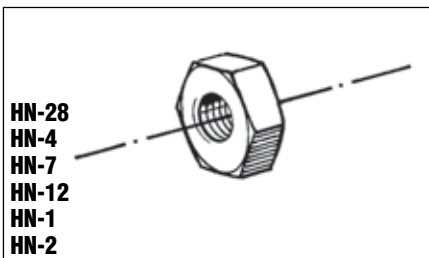

**HN-28**  
**HN-4**  
**HN-7**  
**HN-12**  
**HN-1**  
**HN-2**

**Hex Nut**

- HN-28** 1/4"unc Nyloc
- HN-4** 1/4"unc
- HN-7** 7mm
- HN-12** 8mm
- HN-1** 5/16"unf
- HN-2** 3/8"unf

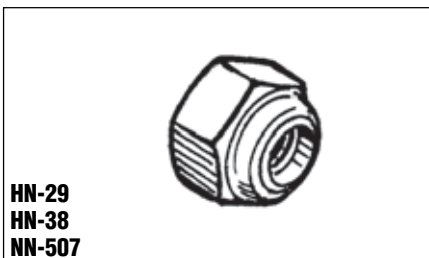

**HN-29**  
**HN-38**  
**NN-507**

**Hex Nut**

- HN-29** 5/16"w Nyloc
- HN-38** 3/8"unc Nyloc
- NN-507** 5/16"unf Nyloc

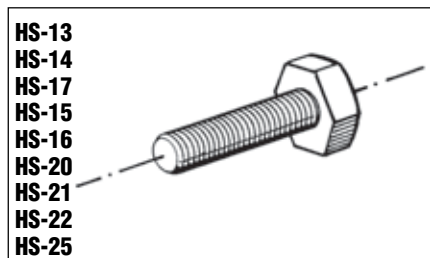

**HS-13**  
**HS-14**  
**HS-17**  
**HS-15**  
**HS-16**  
**HS-20**  
**HS-21**  
**HS-22**  
**HS-25**

**Hex Head Set Screws and Bolts**

- HS-13** 1/4"unc x 1/2" long
- HS-14** 1/4"unc x 3/4" long
- HS-17** 1/4"unc x 1" long
- HS-15** 5/16"unf x 1 1/4" long h/t
- HS-16** 5/16"unc x 2 1/4" long h/t
- HS-20** 5/16"unc x 3/4" long
- HS-21** 3/8"unc x 3 1/4" long h/t
- HS-22** 3/8"unc x 5" long h/t
- HS-25** 5/16"w x 2" long



**SS-6**  
**SS-16**  
**SS-17**  
**SS-18**  
**SS-10**  
**SS-20**  
**SS-19**

**Socket Head Set Screw**

- SS-6** 6mm x 20mm long
- SS-16** 5/16"unc x 7/8" long
- SS-17** 3/8"unc x 3/4" long
- SS-10** 3/8"unc x 1 1/4" long
- SS-18** 8mm x 20mm long
- SS-20** 8mm x 35mm long
- SS-19** 5/16"unc x 1 1/4" long



**ST-12**

**Self Tapping Screw**

1" long to fit 5/32" hole. Suit rubber boots  
Part Nos. 36-100, 36-101, 36-102, 36-103



**28-2**  
**Header Bolt kit**  
High Tensile Bolts with drop-forged 7/16" Hexagon Heads. Pack of 8



**28-6**  
**Zinc plated Timing Case Cover Bolts**  
To suit Chevy Small Block V8. Pack of 10



**28-3**  
**Zinc Plated Intake Manifold Bolts**  
To suit 283-350 S/B Chevy V8 & Chrysler 273-360. Pack of 12



**28-10**  
**Header Bolt Kit, Socket Head Type**  
High Tensile material. Supplied with hexagon key. Pack of 8



**28-4**  
**Chrome Intake Manifold Bolts**  
To suit Ford 289-351 Windsor V8. Pack of 12



**28-5**  
**Zinc plated Oil Pan Bolts**  
To suit Chevy Small Block V8. Pack of 18



*Doug Challinor: Winner 2008-2009 WSID Super Street Bracket  
Photo by Jon Van Daal*



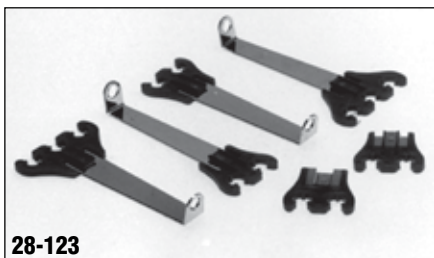

**28-123**  
**Chrome High Lift Looms**  
with Blue Separators  
4 x 2 hole & 2 x 3 hole



**28-124**  
**Deluxe Wire Separators**  
with right angle Chrome Brackets  
8 x 2 hole & 2 x 4 hole

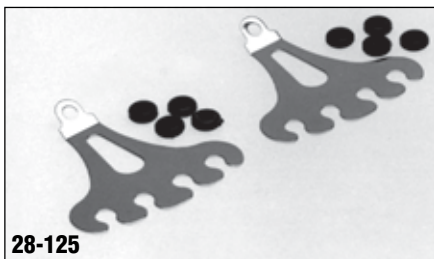

**28-125**  
**Chrome Wire Looms**  
with Rubber Grommets  
Suit 7mm & 8mm cable. 4-hole.  
Pack of 2

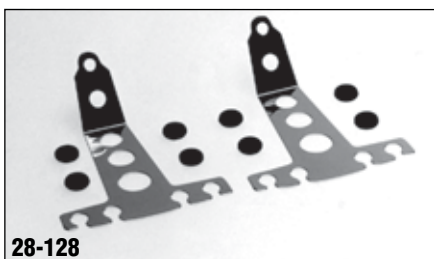

**28-128**  
**Chrome High Lift Wire Looms**  
with Rubber Grommets  
Suit 7mm & 8mm cable. 2 x 4 hole

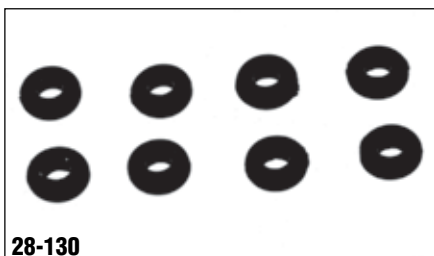

**28-130**  
**Wire Loom Rubber Grommets**  
Suit 7mm & 8mm ignition leads. Pack of 8

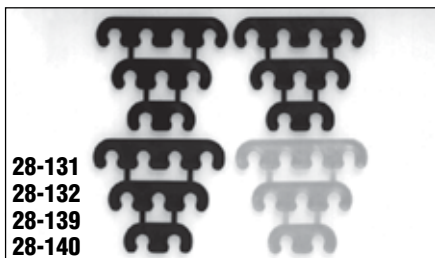

**28-131**  
**28-132**  
**28-139**  
**28-140**  
**Wire Separators**  
2 x 2 hole, 2 x 3 hole, 2 x 4 hole.  
Hi-Temp. Plastic material  
**28-131** Yellow  
**28-132** Blue  
**28-139** Black  
**28-140** Red



**28-193**  
**28-194**  
**28-195**  
**28-196**  
**V8 Ignition Lead Separator Kit**  
Made from Zytel Aircraft Quality Nylon and  
using stainless steel hardware.  
To suit 8mm & 9mm ignition leads  
**28-193** Blue, 6 piece.  
**28-194** Yellow, 6 piece.  
**28-195** Red, 6 piece.  
**28-196** Black, 6 piece.

To suit 10mm & 11mm ignition leads  
**28-222** Blue, 6 piece.  
**28-223** Yellow, 6 piece.  
**28-224** Red, 6 piece.  
**28-225** Black, 6 piece.



**28-213**  
**28-214**  
**28-215**  
**28-216**  
**28-226**  
**28-227**  
**28-228**  
**28-229**  
**Universal 4 Hole Lead Separators 8-9mm dia**  
**28-213** Blue, 2 piece.  
**28-214** Yellow, 2 piece.  
**28-215** Red, 2 piece.  
**28-216** Black, 2 piece.

**Universal 4 Hole Lead Separators 10-11mm dia**  
**28-226** Blue, 2 piece.  
**28-227** Yellow, 2 piece.  
**28-228** Red, 2 piece.  
**28-229** Black, 2 piece.



**28-205**  
**28-206**  
**28-207**  
**28-208**  
**28-209**  
**28-210**  
**28-211**  
**28-212**  
**Vertical Lead Separator Support Brackets**  
**28-205** Blue. Pack of 4  
**28-206** Yellow. Pack of 4  
**28-207** Red. Pack of 4  
**28-208** Black. Pack of 4  
**28-209** Blue. Pack of 6  
**28-210** Yellow. Pack of 6  
**28-211** Red. Pack of 6  
**28-212** Black. Pack of 6

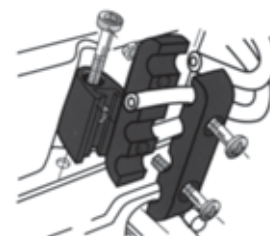

**28-197**  
**28-198**  
**28-199**  
**28-200**  
**28-201**  
**28-202**  
**28-203**  
**28-204**  
**Horizontal Lead Separator Support Brackets**  
**28-197** Blue. Pack of 4  
**28-198** Yellow. Pack of 4  
**28-199** Red. Pack of 4  
**28-200** Black. Pack of 4  
**28-201** Blue. Pack of 6  
**28-202** Yellow. Pack of 6  
**28-203** Red. Pack of 6  
**28-204** Black. Pack of 6

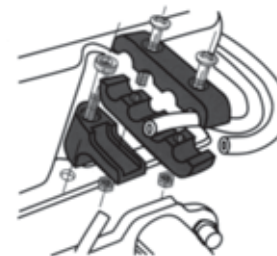

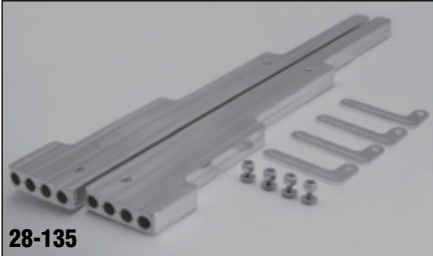

**28-135**  
**Billet V8 Wire Separators**  
Ball Milled Billet Separators. Universal Fitment.

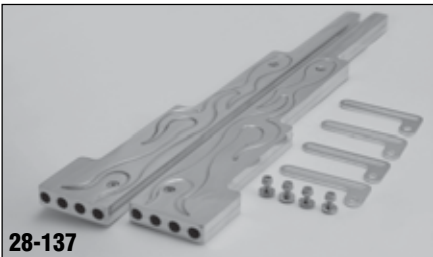

**28-137**  
**Billet V8 Wire Separators**  
Flamed Billet Separators. Universal Fitment.

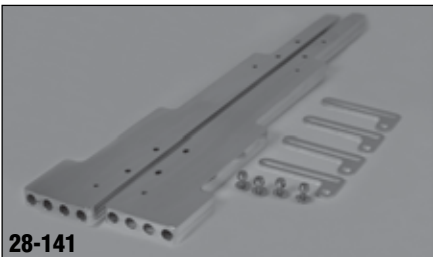

**28-141**  
**Billet V8 Wire Separators**  
Plain Billet Separators. Universal Fitment.



*Photo by Jon Van Daal*



*Danny Lagounaris: 2<sup>nd</sup> place 2008-2009 WSID Super Street Bracket  
Photo by Jon Van Daal*



**28-22**  
**Chrome Distributor Hold Down Clamp**  
Suit Chevy Small Block & Big Block V8 Engine



**28-83**  
**Chrome Fuel Pump Block-off Plate**  
Suit Ford 302-351 Cleveland V8 Engine



**28-148**  
**Chrome Alternator Bracket**  
Suit 1969-on Chevy B/B V8 with long water pump



**28-23**  
**Chrome Distributor Hold Down Clamp**  
Suit Ford Windsor & Cleveland V8 Engine



**28-84**  
**Chrome Fuel Pump Block-off Plate**  
Suit Holden 253-308 V8 Engine

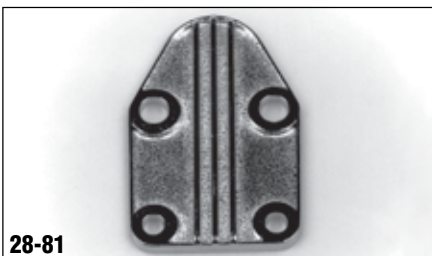

**28-81**  
**Chrome Fuel Pump Block-off Plate**  
Suit Chevy Small Block V8 Engine



**28-146**  
**Chrome Alternator Bracket**  
Suit 1969-1975 Chevy S/B V8 with long water pump



**28-82**  
**Chrome Fuel Pump Block-off Plate**  
Suit Chevy Big Block V8, Ford 289-302 Windsor V8, Chrysler 273-360 V8, Holden 6cyl 1964-on, Ford Falcon 6cyl



**28-147**  
**Chrome Alternator Bracket**  
Suit 1976-1986 Chevy S/B V8 with long water pump





**28-149**

**Chrome Alternator Bracket custom style**  
Suit 1965-1968 Chevy Small Block V8 with short water pump

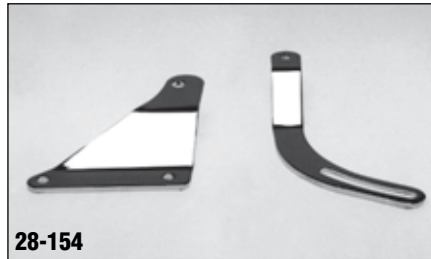

**28-154**

**Chrome Alternator Bracket**  
Suit Ford 1970-on Windsor & Cleveland without air conditioning.

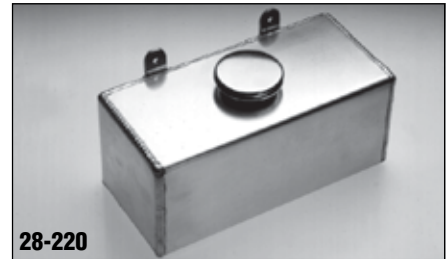

**28-220**

**Aluminium Windscreen Washer Tank**  
with polished stainless steel cap.  
To suit Holden HD to HZ, WB Torana LC to UC



**28-151**

**Chrome Alternator Bracket custom style**  
Suit 1969-1975 Chevy Small Block with long water pump. Also fits Big Block Chevy 1969-onwards.

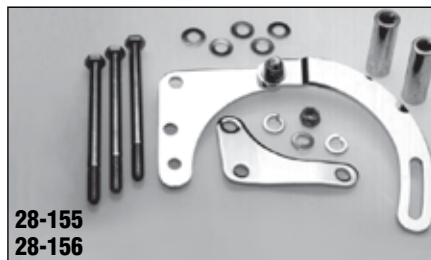

**28-155  
28-156**

**Chrome Low Mount Alternator Bracket Kit**  
Fully adjustable to suit most popular alternators.  
**28-155** Suit S/B Chev. V8 with short water pump  
**28-156** Suit S/B Chev. V8 with long water pump  
Mounts low down on passenger's side at front of engine. This new design kit will suit early & late Bosch alternators, also Delco Remy and Lucas models. Kit is supplied with brackets, bushes and high tensile bolts.  
*Note: Do not use this kit with Gilmer Pulley Conversion Kits as it overloads the bolts.*



**28-219**

**Oil Catch Can**  
Universal fit. Supplied with instruction sheet.



**28-152**

**Chrome Alternator Bracket custom style**  
Suit 1976-1986 Chevy Small Block V8 with long water pump

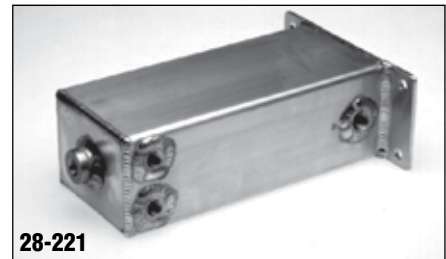

**28-221**

**Aluminium Fuel Injection Surge Tank**  
Universal fit. Supplied with instruction sheet



**28-153**

**Chrome Alternator Bracket**  
Universal fitment, can be cut to length and redrilled to suit application.



**28-165**

**Chrome Heater Hose Support Bracket**  
Universal fitment, supports 1 or 2 heater hoses in position above rocker covers. Mounts on rocker cover flange.

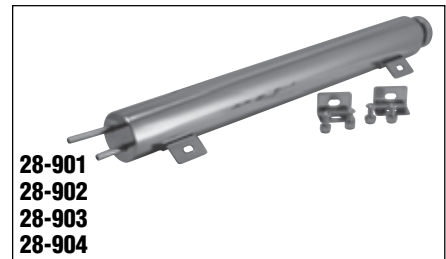

**28-901  
28-902  
28-903  
28-904**

**Radiator Overflow Tank - Stainless steel**  
**28-901** 2 inch dia x 13 inch long  
**28-902** 2 inch dia x 15 inch long  
**28-903** 2 inch dia x 17 inch long  
**28-904** 2 inch dia x 19 inch long



**28-6931**

**Chrome Timing Marker**

Suit Chevy S/B with 7" balancer.  
Fits with Redline 28-105 Chrome Timing Case Cover.

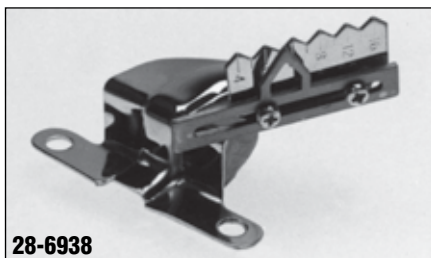

**28-6938**

**Chrome Timing Marker with Adjustable Needle**

Suit Chevy B/B with 8" balancer.  
Fits with Redline 28-106 Chrome Timing Case Cover.

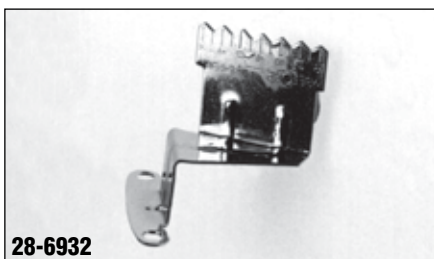

**28-6932**

**Chrome Timing Marker**

Suit Chevy S/B with 8" balancer.  
Fits with Redline 28-105 Chrome Timing Case Cover.

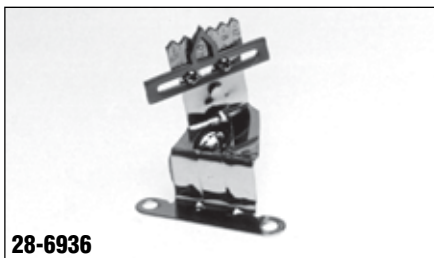

**28-6936**

**Chrome Timing Marker with Adjustable Needle**

Suit Chevy S/B with 7" balancer.  
Fits with Redline 28-105 Chrome Timing Case Cover.

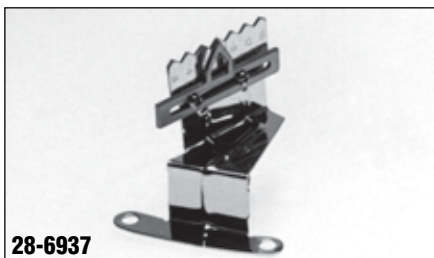

**28-6937**

**Chrome Timing Marker with Adjustable Needle**

Suit Chevy S/B with 8" balancer.  
Fits with Redline 28-105 Chrome Timing Case Cover.



**52-130**

**Carburettor Base Gasket**  
Weber downdraught open type gasket  
suits 10-112 Redline Adaptor

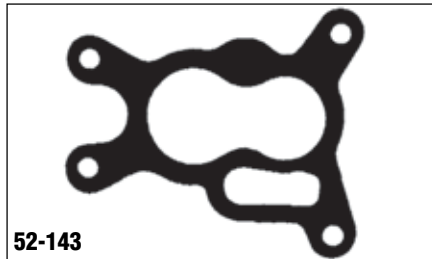

**52-143**

**Carburettor Base Gasket**  
2bbl Laser, Meteor, Mazda 323,  
suits 10-214 Redline Adaptor

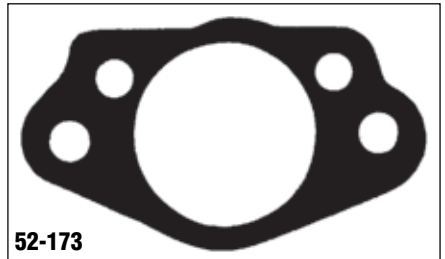

**52-173**

**Air Cleaner Base Gasket**  
1bbl 1 1/2" SU carburettor

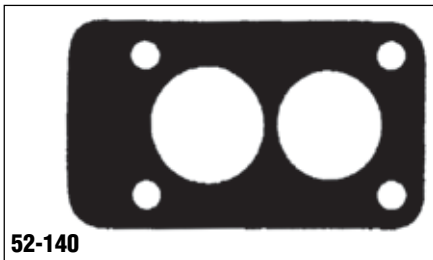

**52-140**

**Carburettor Base Gasket**  
2bbl Datsun, Toyota, etc, extended one end,  
suits 10-112 Redline Adaptor

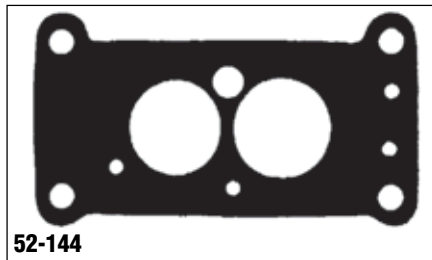

**52-144**

**Carburettor Base Gasket**  
2bbl Toyota 18R, 18RC & 18RU engines  
suits 10-217 Redline Adaptor

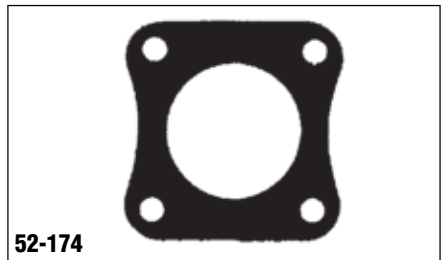

**52-174**

**Carburettor Base Gasket**  
1bbl 1 3/4" SU Carburettor  
& 175CD Stromberg Carburettor



**52-141**

**Carburettor Base Gasket**  
2bbl Datsun 1000, 1200, 120A & 140Y,  
suits 10-212 Redline Adaptor

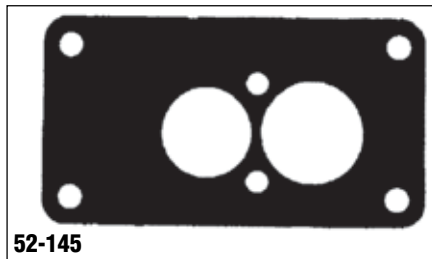

**52-145**

**Carburettor Base Gasket**  
2bbl Toyota 1900cc, TA22-23, TA18, 12R, 3Y,  
suits 10-220 Redline Adaptor

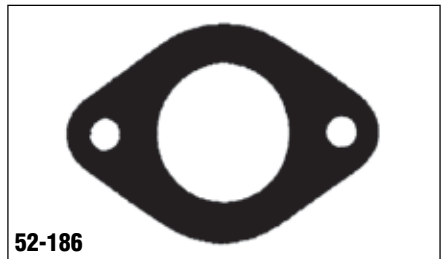

**52-186**

**Carburettor Base Gasket**  
1bbl Stromberg Holden 149-186 (3/8" Studs)



**52-142**

**Carburettor Base Gasket**  
1bbl Base Gasket, universal fitment,  
suits 10-214 Redline Adaptor



**52-172**

**Air Cleaner Base Gasket**  
1bbl 1 1/4" SU carburettor

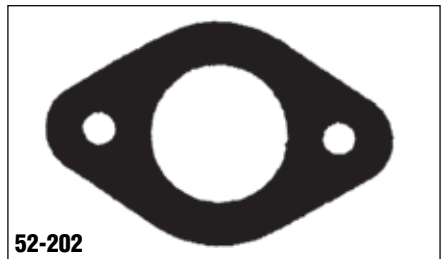

**52-202**

**Carburettor Base Gasket**  
1bbl Stromberg Holden 202 (3/8" Studs)



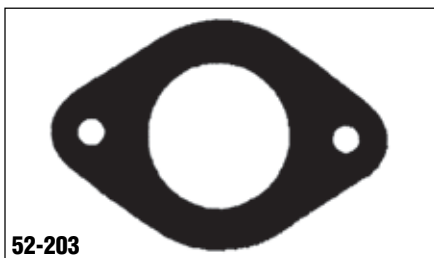

52-203

**Carburettor Base Gasket**

1bbl Stromberg Late Holden 202 (5/16" studs) & Falcon 6cyl X-Flow

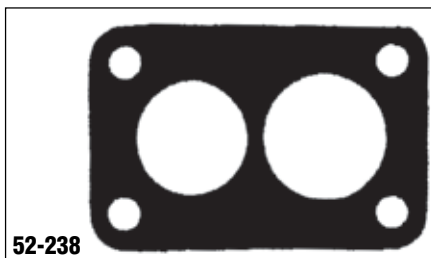

52-238

**Carburettor Base Gasket**

2bbl Datsun 1600, 180B, 200B, 240K, 260C, Toyota Corolla, Corona, Celica, Crown, 1600 Celica TA22, stud centres 80mm x 43mm

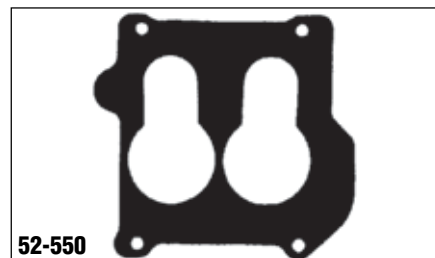

52-550

**Carburettor Base Gasket**

4bbl XD-XE V8 Manifold to Redline 10-550, 10-551, 10-552 & 10-555 Adaptors

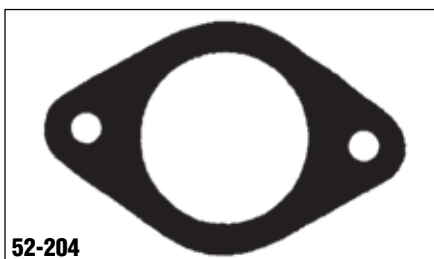

52-204

**Carburettor Base Gasket**

2bbl Weber IDF & IDA Carburettors

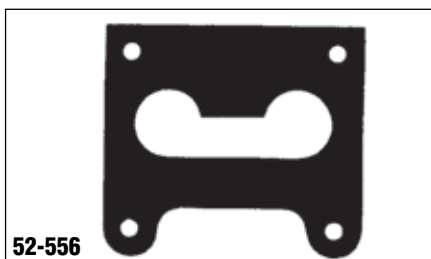

52-556

**Carburettor Base Gasket**

V6 Chevrolet

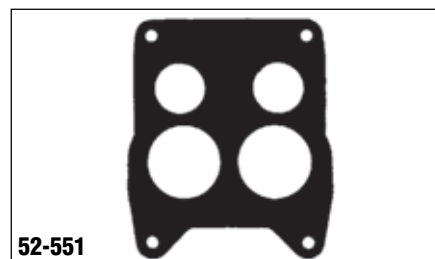

52-551

**Carburettor Base Gasket**

4bbl Spreadbore with small secondaries

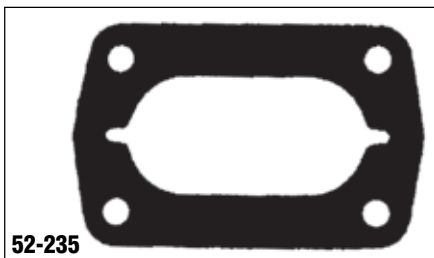

52-235

**Carburettor Base Gasket**

2bbl WW Stromberg Carburettor

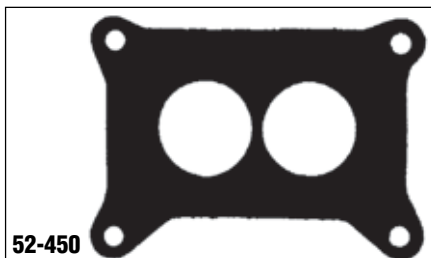

52-450

**Carburettor Base Gasket**

Holley 2bbl 320, 350, 500cfm Carburettors

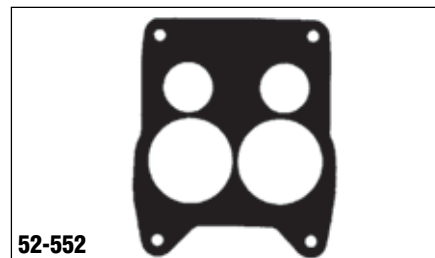

52-552

**Carburettor Base Gasket**

4bbl Spreadbore with large secondaries

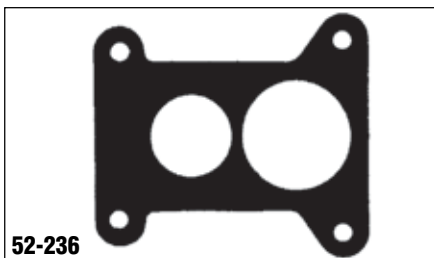

52-236

**Carburettor Base Gasket**

2bbl Holden 4cyl & 6cyl Rochester Varajet Carburettor

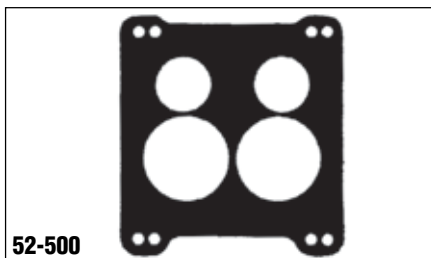

52-500

**Carburettor Base Gasket**

Holley 4bbl Spreadbore, Large base gasket Also fits Carter Thermoquad

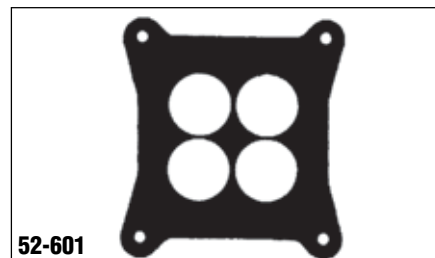

52-601

**Carburettor Base Gasket**

4bbl Square bore gasket with 4 holes

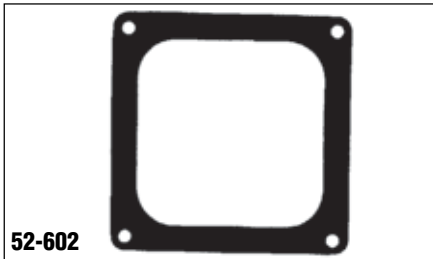

**52-602**  
**Carburettor Base Gasket**  
4bbl Holley Dominator Carburettor



**52-570**  
**Weber Vibration Buffer**  
suit 52-110K



**52-571**  
**Weber Captive Washer**  
suit 52-110K



**52-650**  
**Carburettor Base Gasket**  
4bbl Holley Squarebore with open hole centre

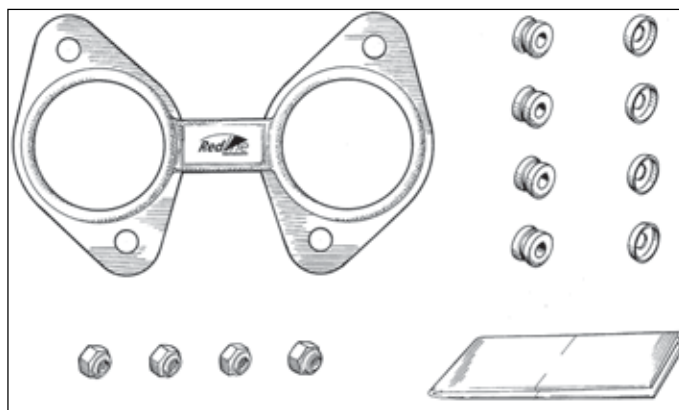

**Soft Mount Kit**  
to suit DCOE Weber, Delorto  
& Solex Sidedraught Carburettors

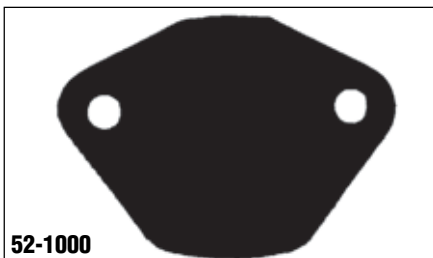

**52-1000**  
**EGR Flange blanking gasket**

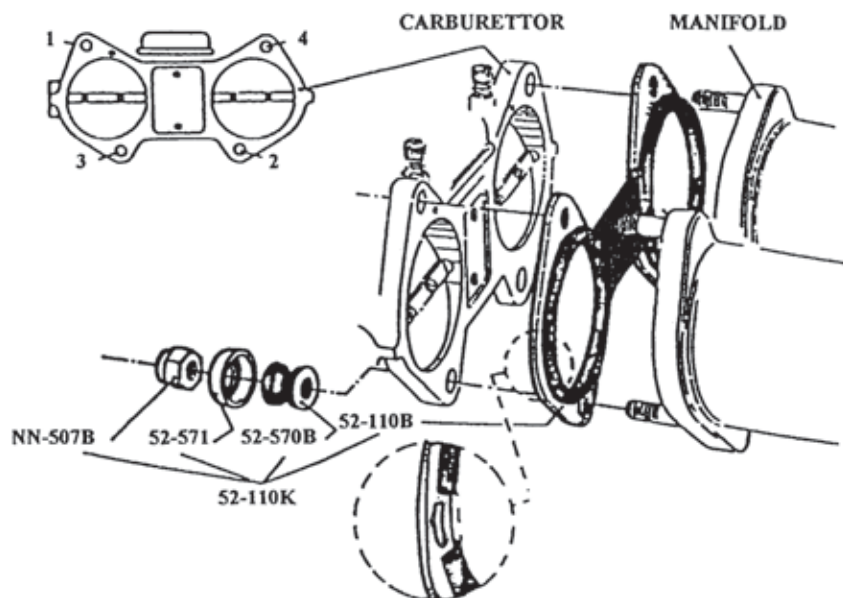

**Assembly instructions for 52-110K**  
tighten nyloc nuts, in the sequence shown, until contact is made between nut, washer and grommet.  
Tighten nut a further 1 1/2 turns, ensuring that 'V' in all grommets is equal.

**Note**

It is important that soft mount kits are fitted between the sidedraught Weber carburettor and the induction manifold.  
The function of these kits are so designed to prevent vibration transmitted from the engine to the carburettor and this in turn prevents flooding of the carburettor. Note fuel pressure should not exceed 4psi.

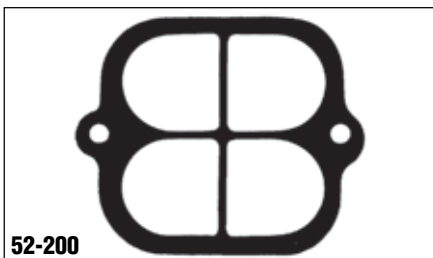

**52-200**  
**Gasket to suit Tunnel Ram Twin 4bbl tops**  
Suits all Redline V8 Tunnel Ram Manifolds

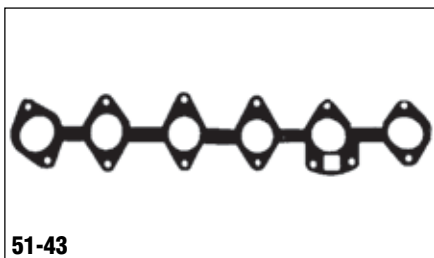

**51-43**  
**Inlet Manifold Gasket**  
Ford 6 cylinder X-flow cast iron head

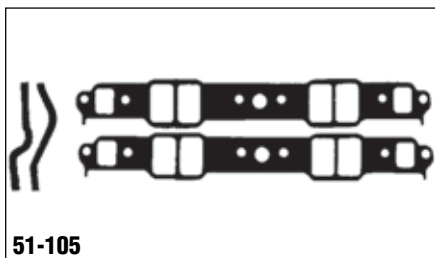

**51-105**  
**Inlet Manifold Gasket**  
Chevy 283-350 V8

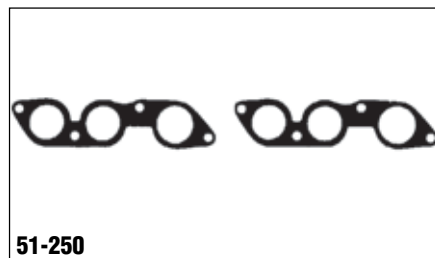

**51-250**  
**Inlet Manifold Gasket**  
Ford 250ci 6 cylinder with 2V head (not X-flow)

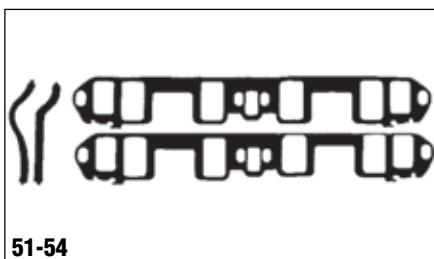

**51-54**  
**Inlet Manifold Gasket**  
Ford 289-302 Windsor V8

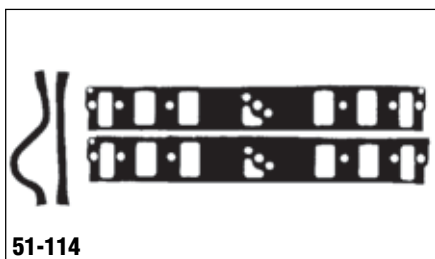

**51-114**  
**Inlet Manifold Gasket**  
Holden 253-308 V8 Red, Blue & Black cylinder heads



**51-337**  
**Inlet Manifold Gasket**  
Ford Cortina 1600cc 4 cylinder X-flow

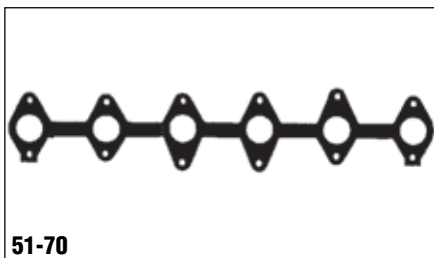

**51-70**  
**Inlet Manifold Gasket**  
Ford 6 cylinder X-flow alloy

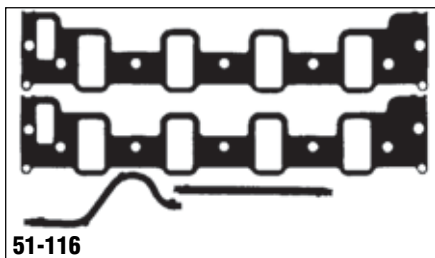

**51-116**  
**Inlet Manifold Gasket**  
Holden 308 with VN-on cylinder heads

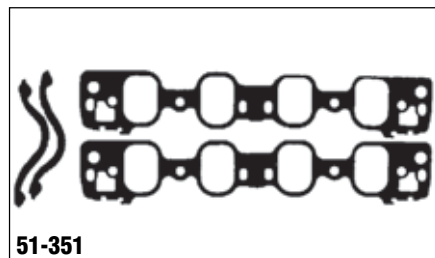

**51-351**  
**Inlet Manifold Gasket**  
Ford 302-351 Cleveland V8 with 4V heads



**51-85**  
**Inlet Manifold Gasket**  
Holden Gemini 4 cylinder

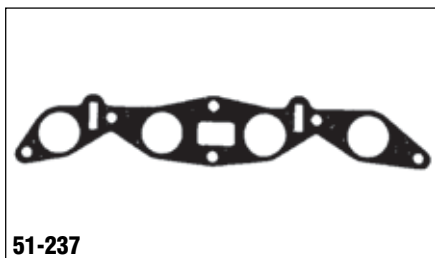



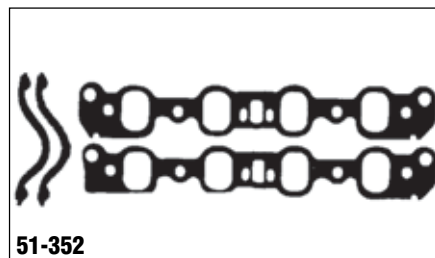

















**51-237**  
**Inlet Manifold Gasket**  
Ford Cortina, Escort 2 litre 4 cylinder





**51-352**  
**Inlet Manifold Gasket**  
Ford 302-351 Cleveland V8 with 2V heads

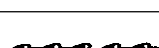

50-009		Collector Cone Gasket. Suits 2 1/2" Header Collector
50-010		Collector Cone Gasket. Suits 3" Header Collector
50-011		Collector Cone Gasket. Suits 3 1/2" Header Collector
50-025		suit Holden 1948-1963 6cyl Engine
50-033		Suit BMC "B" Series Engine, eg MGB 1500-1600cc
50-035		Suit BMC "A" Series Engine, eg Mini 850-1275cc
50-037		Suit Ford Cortina 1200-1500cc Engine
50-041		Suit Ford Falcon 6cyl Pre X-Flow up to 1976
50-042		Suit Chrysler Valiant Slant 6 Engine
50-043		Suit Ford Falcon 6cyl X-Flow Cast-Iron Head Engine
50-044		Suit Chrysler Valiant Hemi-6 Engine
50-054		Suit Ford Falcon 289-302 Windsor V8. Pack of 2
50-065		Suit Holden Red 6cyl 1964-1980
50-066		Suit Holden Red 6cyl 1964-1980 with Modified 12 Port Head
50-068		Suit Mitsubishi 1800-2600cc Astron Engine
50-070		Suit Ford Falcon 6cyl X-Flow Alloy Head Engine
50-072		Suit Toyota Landcruiser 2F 6cyl Engine
50-073		Suit Leyland Rover V8 Engine
50-074		Suit Holden Gemini 1600-2000cc Engine
50-076		Suit Toyota Celica 1600cc Engine
50-080		Suit Suzuki LJ80, 800-1000cc Engine
50-083		Suit Holden Commodore 4cyl 1980-1982 2000cc Engine
50-086		Suit Mitsubishi Galant square port 1400-1600cc Engine
50-087		Suit Holden Blue/Black 6cyl Engine
50-090		Suit Mazda 12A, 13B Rotary Engine

50-100		Exhaust Gasket 'Blank' Sheet
50-102		Suit Toyota Corolla
50-104		Suit Mazda 929 Square Port 4cyl 2000cc Engine
50-105		Suit S/B Chevy V8 Engine. Pack of 2
50-108		Suit Nissan Datsun 1100-1200cc Engine
50-109		Suit Nissan Datsun 1600-2000cc Engine
50-110		Suit Mazda 626, 929 & Ford Laser Round Port 1200cc Engine
50-111		Suit Ford 351 Windsor V8 Engine Long Exhaust Ports. Pack of 2
50-114		Suit Holden V8 253-308ci Red, Blue & Black Engines
50-123		Suit Nissan 2.4 & 2.8 Litre 6cyl Engine
50-124		Suit Ford 1800-2200cc & Mazda 626
50-126		Suit Nissan Pathfinder 4WD, 720 Patrol, Navara 2.0-2.4 Litre Engines
50-127		Suit Toyota Celica 4cyl OHC Crossflow 2 Litre Engine
50-128		Suit Mitsubishi L300 1600-2400cc Engine
50-136		Suit Holden Astra, & Nissan Pulsar 1300-1500cc Engine
50-137		Suit Ford Cortina & Escort 2 Litre Engine
50-138		Suit Toyota 2 Litre to 2.4 Litre 3Y & 4Y Engine, Daihatsu Rocky 3YC 2.2 Litre
50-140		Suit Toyota Landcruiser FJ60 6cyl 4.2 Litre 3F Engine
50-142		Suit Toyota 2 Litre 18RC Engine
50-145		Suit Chevrolet C20 6cyl Truck 300ci Engine.
50-147		Suit Toyota 2.4 Litre Diesel Engine
50-150		Suit Chrysler V8 318-360ci Engine. Pack of 2
50-154		Suit Ford 351ci 4V Cleveland V8 Engine. Pack of 2
50-156		Suit Fiat 124, 1600-1800cc Engine
50-157		Suit Toyota Celica 1981-1985 2 Litre Engine

50-158		Suit Toyota Landcruiser 6cyl 4 Litre Deisel Engine
50-166		Suit Toyota Twin OHC 4cyl 1.6 Litre Engine
50-167		Suit Nissan 1400-1500cc Engine
50-173		Suit Holden Jackaroo, Rodeo 2 Litre & 2.3 Litre Engine
50-175		Suit Chevrolet Big Block 427-454ci Engine. Pack of 2
50-182		Suit Nissan Bluebird & Pintara 2 Litre Engine
50-183		Suit Volkswagen Golf 1500-1600cc Engine
50-185		Suit Toyota Cressida & Supra 6cyl, 2.8 Litre & 3 Litre Engine
50-186		Suit Mitsubishi Lancer, Colt, & Cordia 1400-1600cc Engine
50-189		Suit Ford Laser & Mazda 323 1300-1500cc Engine
50-194		Suit BMW 318-I & 320 Square Port Engines
50-201		Suit Ford V8 Big Block Engines. Pack of 2
50-206		Suit Commodore VL & Nissan 6cyl 3 Litre Engines
50-217		Suit Holden Astra, Camira & Nissan Pulsar 1.5 Litre to 2 Litre Engines
50-218		Suit Holden VN Commodore V8 Engine. Pack of 2
50-219		Suit Ford Falcon EA 6cyl 3.9 Litre Engine
50-222		Suit Holden Commodore V6 3.8 Litre Engine. Pack of 2
50-228		Suit Nissan Patrol 6cyl Petrol engine 2.4 Litre Y60 Engine
50-231		Suit Toyota Hi-Lux Diesel 2.4 Litre Engine
50-234		Suit Mitsubishi V6 Engine. Pack of 2
50-235		Suit Suzuki Swift 1.3 Litre Engine
50-240		Suit Toyota 4-Runner V6 3 Litre Engine. Pack of 2
50-254		Suit Ford 302-351ci 2V Cleveland V8 Engine. Pack of 2
50-707		Suit Ford Cortina X-Flow 1600cc Engine





**510-10**

**TACHOMETER** With internal shift light  
 • Type: Electrical • Range: 0-10,000 RPM  
 • Scale: Full • Fitting: Harness  
 • Dia: 5" • Bezel: Silver



**510-11**

**TACHOMETER** With external pencil shift light  
 • Type: Electrical • Range: 0-10,000 RPM  
 • Scale: Full • Fitting: Harness  
 • Dia: 5" • Bezel: Silver



**258-10**

**OIL PRESSURE** Use Fitting Kit Part No. LK-1  
 • Type: Mechanical • Range: 0-100 PSI  
 • Scale: Full • Fitting: 1/8" NPT  
 • Dia: 2 5/8" • Bezel: Silver



**258-11**

**OIL PRESSURE** Use Sender Part No. 400083  
 • Type: Electrical • Range: 0-100 PSI  
 • Scale: Arc • Fitting: Post & Nut  
 • Dia: 2 5/8" • Bezel: Silver

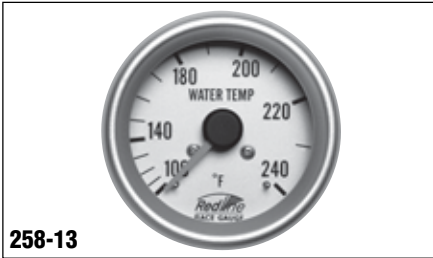

**258-13**

**WATER TEMPERATURE**  
 Capillary length 1600mm  
 • Type: Mechanical • Range: 100-240°F  
 • Scale: Full • Fitting: 1/8" NPT  
 • Dia: 2 5/8" • Bezel: Silver

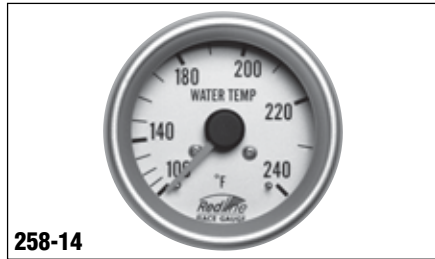

**258-14**

**WATER TEMPERATURE**  
 Capillary length 2600mm  
 • Type: Mechanical • Range: 100-240°F  
 • Scale: Full • Fitting: 1/8" NPT  
 • Dia: 2 5/8" • Bezel: Silver

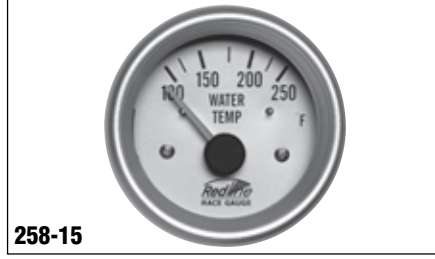

**258-15**

**WATER TEMPERATURE**  
 Use Sender Part No. 400389  
 • Type: Electrical • Range: 100-250°F  
 • Scale: Arc • Fitting: Post & Nut  
 • Dia: 2 5/8" • Bezel: Silver



**258-17**

**AMMETER**  
 • Type: Electrical • Range: 60-0-60 Amps  
 • Scale: Arc • Fitting: Post & Nut  
 • Dia: 2 5/8" • Bezel: Silver



**258-19**

**FUEL PRESSURE** Use Fitting Kit Part No. LK-1  
 • Type: Mechanical • Range: 0-16 PSI  
 • Scale: Full • Fitting: 1/8" NPT  
 • Dia: 2 5/8" • Bezel: Silver



**258-18**

**VOLTMETER**  
 • Type: Electrical • Range: 8-16 Volts  
 • Scale: Arc • Fitting: Post & Nut  
 • Dia: 2 5/8" • Bezel: Silver



**258-25**

**FUEL LEVEL**  
 Use Sender Part No. 301095  
 • Type: Electrical • Range: E-1/2-F  
 • Scale: Arc • Fitting: Post & Nut  
 • Dia: 2 5/8" • Bezel: Silver



**258-27**

**BOOST/VACUUM**  
 Use Fitting Kit Part No. LK-1  
 • Type: Mechanical • Range: 0-30 inHg, 0-30 PSI  
 • Scale: Full • Fitting: 1/8" NPT  
 • Dia: 2 5/8" • Bezel: Silver

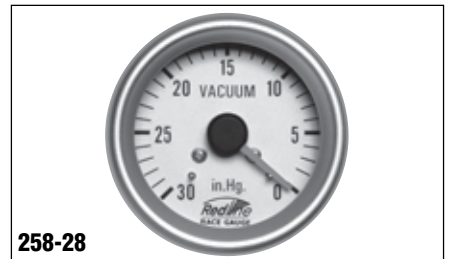

**258-28**

**VACUUM**  
 Use Fitting Kit Part No. LK-1  
 • Type: Mechanical • Range: 0-30 inHg  
 • Scale: Full • Fitting: 1/8" NPT  
 • Dia: 2 5/8" • Bezel: Silver

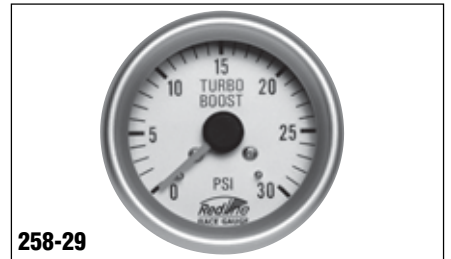

**258-29**

**TURBO BOOST**  
 Use Fitting Kit Part No. LK-1  
 • Type: Mechanical • Range: 0-30 PSI  
 • Scale: Full • Fitting: 1/8" NPT  
 • Dia: 2 5/8" • Bezel: Silver

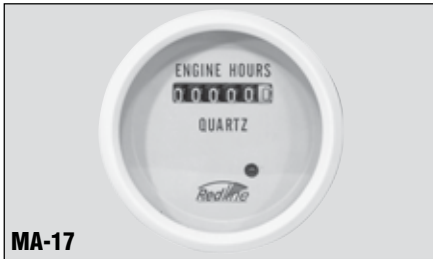

**MA-17**

**ENGINE HOURS**

- Type: Electric
- Range: 0.1 - 99999.9 hours
- Scale: Quartz
- Fitting: Post & Nut
- Dia: 52mm
- Bezel: White



**MA-20**

**TACHOMETER**

- Type: Electric
- Range: 0-6,000 RPM
- Scale: Full
- Fitting: Post & Nut
- Dia: 85mm
- Bezel: White

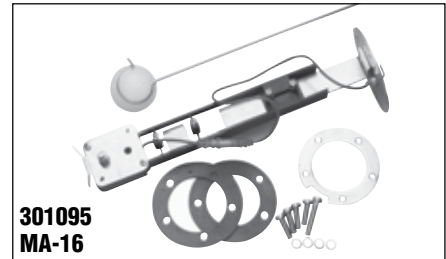

**301095  
MA-16**

**TANK SENDER UNIT**

- 301095** Sender suits Pricol 301829 & 303592 gauges and Redline 258-25 gauges
- Range: 8-186 ohms
- Voltage: 12V
- MA-16** Tank Sender Unit Redline Marine Gauges



**MA-15**

**FUEL TANK LEVEL**

- Type: Electric
- Range: E-1/2-F
- Scale: Arc
- Fitting: Post & Nut
- Dia: 52mm
- Bezel: White

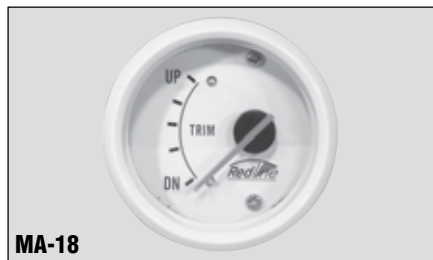

**MA-18**

**TRIM**

- Type: Electric
- Range: Up - Down
- Scale: Arc
- Fitting: Post & Nut
- Dia: 52mm
- Bezel: White



**MA-19**

**PITOT SPEEDOMETER**

- Use Pitot Kit Part No. MA-21
- Type: Mechanical
- Range: 0-80 mph / 70 Knots
- Scale: Full
- Fitting: 1/8" Barb
- Dia: 85mm
- Bezel: White



**MA-14**

**VOLTMETER**

- Type: Electric
- Range: 8-16 Volts
- Scale: Arc
- Fitting: Post & Nut
- Dia: 52mm
- Bezel: White

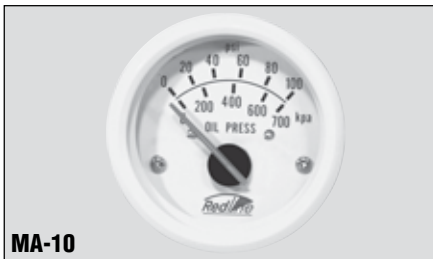

**MA-10**

**OIL PRESSURE**

- Use Pressure Switch Part No. MA-11
- Type: Electric
- Range: 0-100 PSI / 700 kPa
- Scale: Arc
- Fitting: Post & Nut
- Dia: 52mm
- Bezel: White

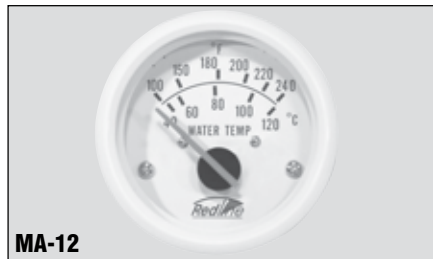

**MA-12**

**WATER TEMPERATURE**

- Use Temp Sender Part No. MA-13
- Type: Electric
- Range: 0-240°F / 120°C
- Scale: Arc
- Fitting: Post & Nut
- Dia: 52mm
- Bezel: White

Make	Model	Oil Gauge Adaptor	Temperature Gauge Adaptor
Alfa	Alfasud, Alfetta	RGA-35	
BMW	Most models	RGA-34	
Chrysler	Valiant 6cyl & V8	RGA-31	
Daihatsu	Charade, 4WD	RGA-36	
Fiat	123, 127, 850	RGA-34	
	124, 125, 128, 130, X1/9	RGA-35	
Ford	Cortina, Escort	RGA-32	
	Falcon XK-XE 6cyl	RGA-32	024-0402NPT
	Falcon XR-XE V8	RGA-32	024-0602NPT
	Bronco, F100, F250, F350	RGA-32	024-0602NPT
	Courier, Econavan, Laser	RGA-36	024-016M
	Meteor, Spectron, Telstar	RGA-36	024-016M
GMH	Astra LD, Camira All	RGA-35	
	Astra LB, LC, Barina, Drover	RGA-36	
	Gemini, Jackaroo, Rodeo, Shuttle	RGA-36	024-016M
	Commodore (Starfire)	RGA-32	
	All Holden Aussie 6cyl & V8	RGA-32	024-0802NPT
	Chevrolet Small Block V8	RGA-31	024-0802NPT
Hillman	Avenger, Hunter	RGA-31	024-1002NPT
Honda	Accord, Civic, Prelude	RGA-36	024-016M
Isuzu	KB25, 40	RGA-36	024-016M
Leyland	Morris "A & B" Series Engines	RGA-31	024-1002NPT
Mitsubishi	All models	RGA-36	
Nissan	Most models except locally manufactured Pulsar	RGA-36	024-016M
Renault	All models except R30	RGA-35	
SAAB	All models	RGA-32	
Subaru	Most models	RGA-36	024-016M
Suzuki	All models	RGA-36	024-016M
Toyota	All models	RGA-36	024-016M
Triumph	All models	RGA-31	024-1002NPT
Volvo	144, 164, 242, 245, 264	RGA-31	024-1002NPT
Volkswagen	Beetle, Type 3, Golf, Passat	RGA-33	

**Oil Gauge Adaptor Sizes**

Part No.	Size
RGA-31	1/8" - 27NPTF
RGA-32	1/4" - 18NPTF
RGA-33	M10 - 1mm
RGA-34	M12 - 1.5mm
RGA-35	M14 - 1.5mm
RGA-36	1/8" - 28BSPT
14-12	Fuel Line Adaptor fit 1/8" NPT Fuel Pressure Gauge

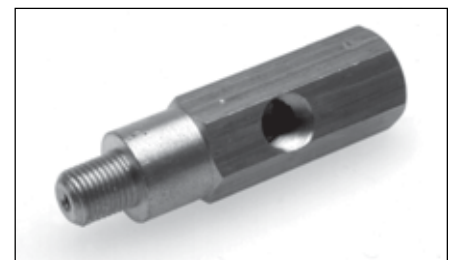
**Temperature Sender Adaptor Sizes**

Part No.	OD Size	ID Size
024-0402NPT	1/4" NPT	1/8" NPT
024-0602NPT	3/8" NPT	1/8" NPT
024-0802NPT	1/2" NPT	1/8" NPT
024-016M	M16	1/8" NPT
024-1002NPT	5/8" UNF	1/8" NPT





**LK-1**

**Pressure Line Kit**

Suit Pricol Oil, Vacuum, Boost & Fuel Pressure Gauges



**LK-2**

**Pressure Line Kit**

Suit Smiths Oil Pressure Gauge



**400-1**

**Gauge Panel, Black**

Single hole 52mm (2")



**400-2**

**Gauge Panel, Black**

Two hole 52mm (2")

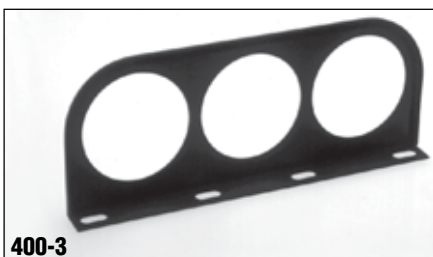

**400-3**

**Gauge Panel, Black**

Three hole 52mm (2")

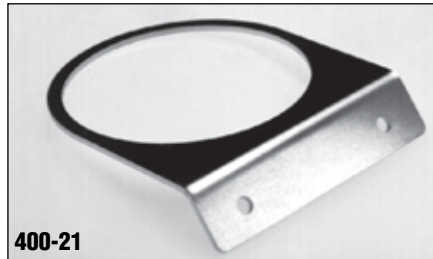

**400-21**

**Gauge Panel, Silver**

Single hole 80mm. Suits Smiths Tachometer



**400-25**

**Tachometer Housing**

Suits 80mm Smiths Tachometer

**400-25** Silver Anodised



**BA-**

**Smiths Temperature Gauge Sender Adaptors**

Part No.	OD Size	ID Size
<b>BA-08N10UNF</b>	1/2" NPT	5/8" UNF Female
<b>BA-0608N</b>	3/8" BSP Male	1/2" NPT Male
<b>BA-1010UNF</b>	5/8" UNF Female	5/8" UNF Male
<b>BA-0375UNF</b>	5/8" UNF Male	3/8" BSP Male
<b>BA-0376UNF</b>	5/8" UNF Male	3/8" NPT Male
<b>BA-0377UNF</b>	5/8" UNF Male	3/8" BSPT Male



**A3-0402**

**A3-0502**

**A3-0602**

**Brass Fitting**

**A3-0402** 1/8" BSP one end, suits 1/4" dia. steel fuel line other end.

**A3-0502** 1/8" BSP one end, suits 5/16" dia. steel fuel line other end.

**A3-0602** 1/8" BSP one end, suits 3/8" dia. steel fuel line other end.

All these fittings suit 14-12 Fuel Line Adaptor and Purolator Fuel Pressure Regulators

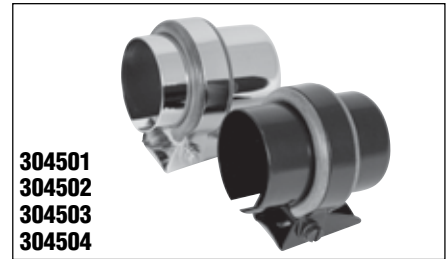

**304501**  
**304502**  
**304503**  
**304504**

**Gauge Pods**

Pod to suit capillary 52mm (2") gauge.

**304501** Chrome

**304502** Black

Pod to suit non-capillary 52mm (2") gauge.

**304503** Chrome

**304504** Black

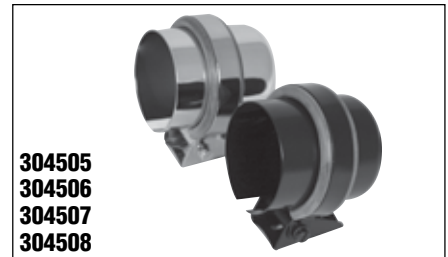

**304505**  
**304506**  
**304507**  
**304508**

**Gauge Pods**

Pod to suit capillary 66mm (2 5/8") gauge.

**304505** Chrome

**304506** Black

Pod to suit non-capillary

66mm (2 5/8") gauge.

**304507** Chrome

**304508** Black

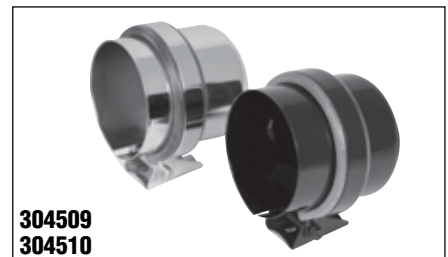

**304509**  
**304510**

**Gauge Pods**

Pod to suit 85mm Tachometers.

**304509** Chrome

**304510** Black



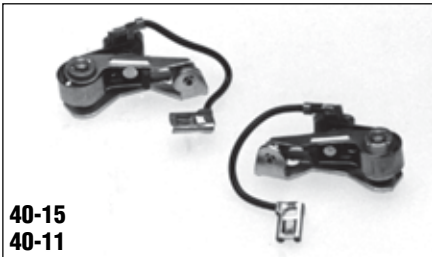

**40-15**  
**40-11**

**Ignition Points**

**40-15** Suit Redline Dual Point Conversion, also Ford V8 Bosch Distributor

**40-11** Suit Redline Dual Point Conversion, also Holden 6cyl, V8, Ford 6cyl, & Chrysler Valiant 6cyl with Bosch Distributor only

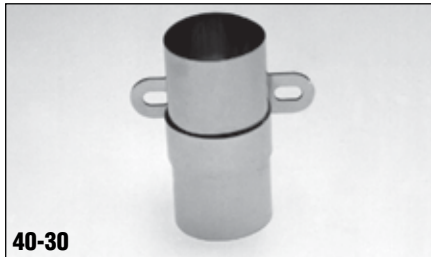

**40-30**

**Chrome Coil Cover**

Universal fitment



**40-20**

**Ignition Points**

Suit most Mallory 4, 6, & 8cyl Distributors. Not with Vacuum Advance



**40-225**

**Ignition Condenser, 0.3mfd capacity**

Suits Mallory & Chevy Delco Remy distributors



**40-27**

**Chrome 12V Sports Coil, 40,000 volts**

Supplied with chrome bracket.

*Note: If ignition system is not resisted, use Redline 40-6002 Resistor*



**40-65**  
**40-114**  
**40-254**

**Dual Point Conversion Kit**

**40-65** Suit Holden 6cyl 1969-1980, Ford 6cyl 250ci 1970-1979 & Chrysler Valiant 6cyl VG-VH standard & Pacer. Bosch Distributor only

**40-114** Suit Holden 253-308 V8 1969-1980. Bosch Distributor only

**40-254** Suit Ford 302-351 Cleveland V8 1970-1979. Bosch Distributor only

Dual points dramatically increase voltage output. For maximum increase use Redline 40-27 Coil

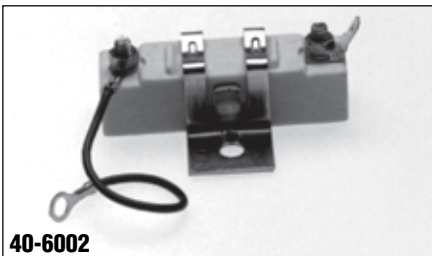

**40-6002**

**Ignition Coil Resistor, 1.6 ohms**

To be used in conjunction with Redline 40-27 Chrome Coil if the original ignition is not resisted type.



**30-77**

**Rubber Bonnet Hooks**

Universal Fitment.  
Supplied with brackets & screws



**48-86**

**Bobby Pins**

Suit 48-81 Hood Pin Kit. Pack of 2

**Note**

All Hood Pin Kits should only be used in conjunction with original manufacturer's hood lock. Hood Pin Kits should never be used to replace original manufacturer's hood lock.

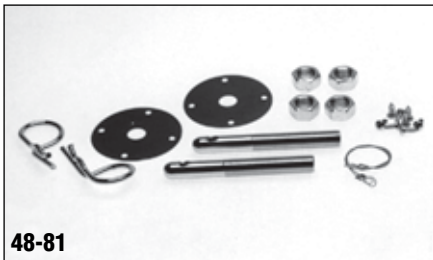

**48-81**

**Hood Pin Kit Standard Type**

Includes bobby pins



**48-87**

**Snap Rings**

Suit 48-83 Hood Pin Kit. Pack of 2



**48-83**

**Hood Pin Kit Deluxe Type**

Includes snap rings & lanyards



**48-88**

**Lanyards, large type**

Suit 48-83 Hood Pin Kit. Pack of 2



**48-84**

**Hood Pin Kit Standard Locking Type**



**48-90**

**48-91**

**48-92**

**48-93**

**Racing Style Hood Pin Kit**

**48-90** Silver Deluxe

**48-91** Red Anodised

**48-92** Blue Anodised

**48-93** Gold Anodised



**36-73**

**Chrome T Shift Handle**  
Universal fitment



**36-130**

**Swept Back Deluxe Wood Shift Knob**



**36-144**

**Red Bullet Alloy Shift Knob**  
With carbon fibre centre



**36-74**

**Polished Aluminium T Shift Handle**  
Universal fitment



**36-133**

**Silver Bullet Alloy Shift Knob**



**36-145**

**Blue Bullet Alloy Shift Knob**  
With carbon fibre centre

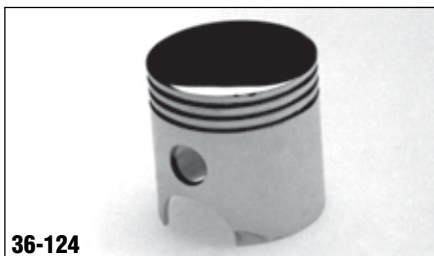

**36-124**

**Chrome Piston Gear Knob**  
Supplied with 2 nylon inserts and locking screws



**36-134**

**Gripper Alloy Shift Knob**  
Dark grey finish with black grooved rubber grip



**36-147**

**Red Leather & Carbon Fibre Shift Knob**



**36-125**  
**36-129**

**Skull Gear Knob**  
Supplied with 2 nylon inserts and locking screws

**36-125** Chrome  
**36-129** Chrome with light-up LED Eyes



**36-136**

**Long Style Alloy Shift Knob**  
Dark grey finish



**36-148**

**Yellow Leather & Carbon Fibre Shift Knob**



**36-149**

**Blue Leather & Carbon Fibre Shift Knob**



**30-67**  
**Machined Aluminium  
Piston Door Lock Knob**  
Universal Fitment. Pack of 2



**30-72**  
**Door Lock Knobs**  
Black chrome with textured insert, self-threading, anti-theft type. Pack of 2



**30-60**  
**Chrome Dice Door Lock Knob**  
Pack of 2



**30-68**  
**Skull Door Lock Knobs**  
Universal fitment, self threading. Pack of 2  
**30-68** Chrome



**30-73**  
**Wood Barrel Door Lock Knobs**  
Universal fitment, self-threading. Pack of 2



**30-61**  
**Chrome 8-Ball Door Lock Knob**  
Pack of 2

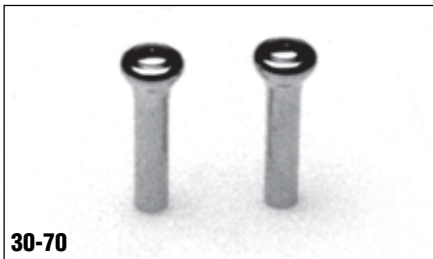

**30-70**  
**Chrome Door Lock Knobs**  
To suit Ford or Holden. Pack of 2

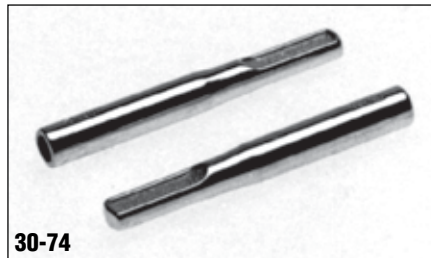

**30-74**  
**Chrome Headless Door Lock Knobs**  
Universal fitment, Anti-Theft type. Pack of 2



**30-62**  
**30-63**  
**30-64**  
**Chrome Sniper Knob**  
Pack of 2  
**30-62** With blue gem in top  
**30-63** With green gem in top  
**30-64** With amber gem in top



**30-75**  
**Chrome Door Lock Knobs with wood insert**  
Universal fitment. Self-threading, anti-theft type. Pack of 2



**30-71**  
**Chrome Door Lock Knobs**  
Universal fitment, self threading. Pack of 2



**30-76**  
**Chrome Headless Door Lock Knobs**  
Short style, universal fitment. Self-threading, anti-theft type. Pack of 2



**30-66**  
**Chrome Skull & Crossbones Door Lock Knob**  
Pack of 2



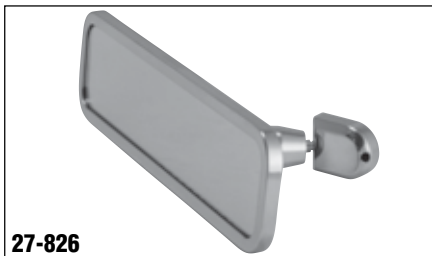

**27-826**

**Polished Billet Mirror**  
Size 237mm x 60mm

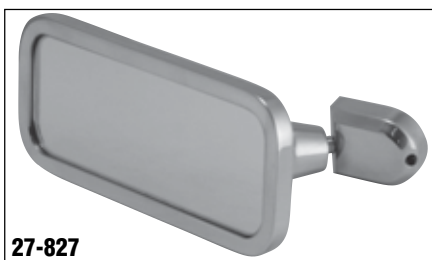

**27-827**

**Polished Billet Mirror**  
Size 140mm x 60mm



**27-828**

**Chrome Bullet Racing Mirror**  
4 inch



**32-12**

**Tailshaft Safety Hoop**  
Universal fitment. Adjustable type. Supplied with all nuts and bolts. When fitted prevents tailshaft from falling to the roadway with the possibility of rolling the vehicle over and/or severe damage to the underside of the vehicle and diff housing. Located at the front end of the tailshaft and bolted to the floor. Adjust to suit tailshaft movement.



**32-36**  
**32-37**  
**32-38**  
**32-39**

**Tyre Valve Caps**  
Aluminium anodised with rubber 'O' ring seal.  
Pack of 4  
**32-36** Silver  
**32-37** Red  
**32-38** Blue  
**32-39** Gold



**32-60**  
**32-61**

**Skull Number Plate, Tyre Valve Caps**  
Pack of 4  
**32-60** Threaded hole in bottom of head  
**32-61** Threaded hole in back of head



**36-100**

**Rubber Gear Shift Boot**  
Universal Fitment. 5 1/4" wide x 6 1/4" long.  
Round shift stick hole



**36-101**

**Rubber Gear Shift Boot**  
Universal Fitment. 5 1/4" wide x 6 1/4" long.  
Rectangular centre hole

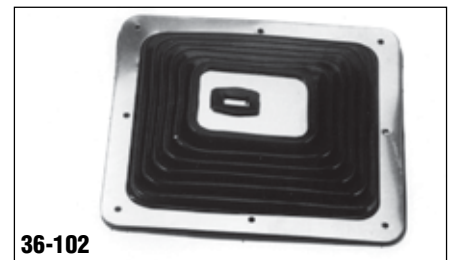

**36-102**

**Rubber Gear Shift Boot**  
Universal Fitment. 8" wide x 9" long.  
Rectangular centre hole



**36-104**

**Vinyl Gear Shift Boot**  
Universal Fitment. 5 1/4" wide x 6 3/8" long



**36-105**  
**36-106**  
**36-107**  
**36-108**

**Leather Gear Shift Lever Boot**  
**36-105** Red  
**36-106** Blue  
**36-107** Yellow  
**36-108** Black



**36-202**  
Short Throw Gear Shift Lever  
Suits Honda Integra 1990-on



**44-500**  
Dimmer Switch Pedal Surfer Style

**Note**  
Due to manufacturers' constant changes it is impossible to guarantee that the gear shift lever listed will fit all makes and models listed



**36-203**  
Short Throw Gear Shift Lever  
Suits Toyota Corolla 1992-on



**44-510**  
Surfer Gas Pedal



**36-204**  
Short Throw Gear Shift Lever  
Suits Nissan



**36-205**  
Short Throw Gear Shift Lever  
Suits Mitsubishi Mirage 1997-on



Photo by Jon Van Daal



**44-8607**  
**Billet Accelerator Pedal**



**47-8149**  
**Tail light with blue dot**  
Suits Ford



**BB27**  
**Battery Box**  
Internal size W180 x L275 x H 200mm



**44-9507**  
**High Tech Accelerator Pedal**  
Chrome Plated



**47-8150**  
**Tail Light**  
39 Ford



**BB32**  
**Battery Box**  
Internal size W185 x L325 x H 200mm



**47-8865**  
**Indicator light**  
Amber indicator light 44mm Wide x 28mm High x 41mm Deep



**PBB32**  
**Power Battery Box**  
Internal size W185 x L325 x H185mm



**47-8866**  
**Indicator light**  
Amber indicator light 60mm Wide x 38mm High x 50mm Deep

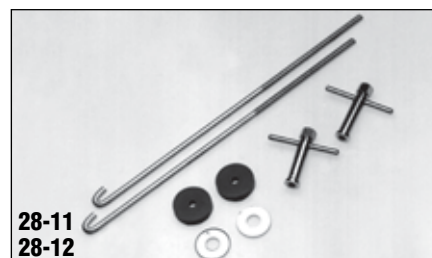

**28-11**  
**28-12**  
**Deluxe Battery Hold-Downs 10"**  
with 'T' Bar  
**28-11** 'J' Style Clamps. Pack of 2  
**28-12** 'L' Style Clamps. Pack of 2

Model	Year
<b>Holden</b>	
FX	1948-1953
FJ	1953-1956
FE	1956-1958
FC	1958-1959
FB	1960-1961
EK	1961-1962
EJ	1963-1964
EH	1964-1965
HD	1965-1966
HR	1966-1968
HK	1968-1969
HT	1969-1970
HG	1970-1971
HQ	1971-1974
HJ	1975-1976
HX	1976-1977
HZ	1977-1978
WB	1980-1984

<b>Holden Commodore</b>	
VB	1978-1980
VC	1980-1983
VH	1983-1985
VK	1985-1986
VL	1986-1988
VN	1988-1991
VP	1991-1993
VR	1993-1995
VS	1995-1998
VT	1998-2000
VX	2000-2002
VY	2002-2004
VZ	2004-2006
VE	2006-

<b>Holden Torana</b>	
LC	1969-1970
LJ	1970-1973
LH	1974-1975
LX	1975-1976
UG	1976-1978

Model	Year
<b>Ford Falcon</b>	
XK	1960-1962
XL	1962-1963
XM	1964-1965
XP	1965-1966
XR	1967-1968
XT	1968-1969
XW	1969-1970
XY	1970-1971
XA	1972-1973
XB	1974-1975
XC	1976-1978
XD	1979-1982
XE	1982-1984
XF	1984-1988
EA	1989-1990
EB	1991-1992
ED	1993-1994
EF	1994-1996
EL	1996-1997
AU	1998-2002
BA	2002-2005
BF	2005-
FG	2008

Model	Year
<b>Chrysler</b>	
R Series	1962
S Series	1962-1963
AP 5	1963-1965
AP 6	1965-1966
VC	1966-1967
VE, VF, VG	1968-1971
VH	1972-1973
VJ, CJ, CK	1973-1975
CL, CM	1976-1978
CV, VC	1978-1981
<b>Centura</b>	
Kb-Kc	1975-1978
<b>Charger</b>	
VG, VH, VJ, VK, CL	1970-1978
<b>R/T Charger</b>	
VH, E37, E38, E49, E55	1971-1972



Photo by Jon Van Daal



air filter	47-54	Gilmer drives	72
air filter elements & accessories	56-58	heater hose support bracket	78
alternator brackets	77	hood pin kits	92
aluminium alloy pulleys	72	ignition lead support kits	75-76
battery boxes	97	ignition parts	91
carburettor adaptor hardware kit	19	inlet manifold 4 cylinder	22-24
carburettor adaptors & marine wedges	14-18	inlet manifold 6 cylinder	25-26
carburettor base gaskets	80-82	inlet manifold 8 cylinder	27-29
carburettor gasket & renew kits	2	inlet manifold gaskets	83
carburettor linkage kits	42-46	instrument adaptors & accessories	89-90
carburettor spare parts	3-7,8	lamps	97
carburettor throttle control components	35-40	manifold studs	73
dipsticks	71	mirrors	95
distributor hold-down clamps	77	nuts & bolts	73-74
doorlock knobs	94	oil caps	65-66
engine nuts, bolts, washers & studs	73-74	oil filter cover	70
engine oil pans	69	oil pans	69
exhaust gaskets	84-86	radiator cap cover	70
flywheel dust covers	70	radiator overflow tank	78
fuel block triple outlet	34	ram air sox	60
fuel fittings	32-34	ram tubes	59
fuel hose	33	rocker covers	61-64
fuel hose clamps	33	rocker cover accessories	65-67
fuel injection pressure regulator	34	rocker cover gaskets	67
fuel injection surge tank	78	surfer pedals	96
fuel lines	32	thermostat housings	68
fuel pressure gauges	34	throttle balls	35
fuel pumps	34	throttle cables	41
fuel pump blockoff plates	77	throttle cable brackets	40
fuel pump valves	34	timing case covers	70
gauges	87-88	timing markers	79
gear shift boots	95	transmission oil pans	69
gear shift knobs	93	tyre valve caps	95
gear shift levers	96	windscreen washer tank	78
Gilmer belts	72		

Part No.	Page	Part No.	Page	Part No.	Page	Part No.	Page	Part No.	Page	Part No.	Page
024-016M	89	10-552	16	12-302	27	12-66	26	14-43	33	16-204	47
024-0402N	89	10-553/4	17	12-3038	26	12-67	26	14-44	33	16-205	47
024-0602N	89	10-555	17	12-3040	24	12-68	26	14-516FH	33	16-206	47
024-0802N	89	10-556	17	12-3044	24	12-70	25	14-53	32	16-207	47
024-1002N	89	10-557	17	12-3047	22	12-71	26	14-54	32	16-208	47
10-112	14	10-558	18	12-3048	22	12-72	26	14-552B	33	16-209	47
10-112HK	19	10-559	18	12-3060	23	12-77	26	14-553B	33	16-211	47
10-187	14	10-560	17	12-3062	23	12-8	73	14-554B	33	16-212	47
10-212	14	10-561	17	12-3063	23	12-9	73	14-60	34	16-213	47
10-213	14	108-1	6	12-308/12-1	28	134-13	7	14-61	34	16-214	47
10-214	14	108-3	7	12-308/12-1	28	14-12	33	14-617	33	16-215	47
10-215	14	108-4	7	12-309	28	14-12	89	14-62	34	16-217	47
10-216	14	108-5	7	12-3093	22	14-14FH	33	14-64	34	16-218	47
10-217	14	108-6	7	12-3095	24	14-20	32	14-65	34	16-219	47
10-218	14	108-7	7	12-3112	23	14-210	33	14-66	34	16-22	53
10-220	15	108-8	7	12-3114	23	14-212	33	14-70	34	16-222	47
10-2215	17	108-9	7	12-3115	23	14-213	33	14-80	34	16-224	47
10-2216	17	10-9134	18	12-3115	23	14-214	33	14-804	34	16-225	47
10-2222	17	10-9135	18	12-3118	22	14-215	33	14-805	34	16-241	49
10-2224	17	10-9136	18	12-3124	23	14-216	33	14-806	34	16-242	49
10-2236	17	10-9137	18	12-3126	26	14-224	32	14-854	34	16-243	49
10-230	15	116-1	8	12-3130	26	14-230	32	14-896	34	16-244	49
10-231	15	116-151	8	12-3131	26	14-231	32	15-146	3	16-245	49
10-232	15	116-2	8	12-3132	22	14-232	32	15-205	3	16-246	49
10-232HK	19	116-3	8	12-3133	24	14-233	33	15-369	3	16-248	49
10-233	15	116-5	8	12-3135	23	14-234	33	15-370	3	16-249	49
10-233HK	19	116-601	8	12-3136	23	14-235	32	15-40K	3	16-251	47
10-234	15	116-602	8	12-3142	24	14-238	33	15-567	3	16-252	47
10-235	15	12-10	73	12-3143	28	14-24	32	15-600	4	16-253	49
10-237	15	12-114	27	12-3144	28	14-255	33	15-601	4	16-254	49
10-240	15	12-116	27	12-3146	22	14-26	32	15-645	3	16-255	49
10-241	15	12-118	28	12-3147	22	14-27	32	15-646	3	16-258	49
10-3203	17	12-120/12-2	28	12-3149	23	14-28	32	15-647	4	16-26	53
10-501	15	12-121	27	12-3206	23	14-289 3	4	16-1	53	16-261	49
10-502	15	12-123	27	12-3207	22	14-29	32	16-10	54	16-262	49
10-503	15	12-125/12-2	27	12-3305	22	14-30	33	16-11	53	16-263	49
10-504	15	12-126	28	12-351/12-1	27	14-309	34	16-111	51	16-264	49
10-507	16	12-14	27	12-351/12-1	27	14-31	32	16-112	51	16-265	49
10-508	16	12-154	27	12-43	25	14-32	33	16-113	51	16-266	49
10-509	16	12-155	27	12-44	25	14-33	33	16-114	51	16-268	49
10-510	16	12-159/12-2	27	12-45	25	14-34	33	16-13	53	16-269	49
10-512	16	12-18	23	12-46	25	14-349	34	16-14	53	16-27	53
10-513	16	12-19	24	12-47	25	14-35	7	16-15	53	16-272	49
10-514	16	12-20	24	12-48	25	14-350	34	16-17	53	16-273	49
10-515	16	12-22	24	12-52	25	14-351	34	16-171	59	16-275	49
10-516	16	12-23	24	12-53	25	14-38	33	16-172	59	16-276	49
10-517	16	12-24	22	12-536	73	14-38FH	33	16-173	59	16-277	49
10-521	16	122-49(size)	7	12-538	73	14-39	33	16-174	59	16-278	49
10-550	16	12-3009	22	12-54	25	14-40	33	16-18	53	16-279	50
10-550HK	19	12-3013	25	12-61	26	14-41	33	16-19	53	16-280	50
10-551	16	12-3019	22	12-65M	26	14-42	33	16-2	53	16-30C	53

Part No.	Page	Part No.	Page	Part No.	Page	Part No.	Page	Part No.	Page	Part No.	Page
16-31C	53	16-87	59	20-1616	19	21-30	55	24-8012	63	26-62	67
16-32C	53	16-88	59	20-1617	5	21-31	55	24-8013	63	26-63	67
16-33C	53	16-9	53	20-1617	19	21-32	55	24-8014	63	26-64	65
16-4	53	18-10	56	20-1619	19	21-33	55	24-8022	63	26-65	65
16-41	54	18-100	56	20-1620	19	21-4	57	24-8024	63	26-66	65
16-42	54	18-12	56	20-2	4	21-80	58	24-8033	63	26-68	65
16-43	54	18-134	56	20-219	14	22-12	68	24-8034	63	26-69	65
16-44	54	18-135	56	20-27	4	22-13	68	24-8042	63	26-70	67
16-45	54	18-1357	52	20-27B	4	22-15	68	24-8043	63	26-72	67
16-46	54	18-1358	52	20-29	4	22-16	68	24-8044	63	26-73	67
16-48	54	18-136	56	20-29-2	4	22-51-0	68	24-8052	64	26-79	65
16-49	54	18-140	56	20-29B	4	22-52-0	68	24-8053	64	26-80	65
16-5	53	18-142	56	20-2B	4	22-53-0	68	24-8054	64	26-81	65
16-501	54	18-143	56	20-30	4	22-65-0	68	24-8073	64	26-82	65
16-502	54	18-144	57	20-30B	4	22-66-0	68	24-8074	64	26-83	65
16-503	54	18-149	57	20-30-2	4	22-67-0	68	25-347	5	26-84	65
16-504	54	18-150	57	20-31	4	22-68-0	68	25-504	5	26-90	66
16-505	54	18-151	57	20-31B	4	22-69-0	68	25-510	5	26-91	66
16-506	54	18-1582	52	20-31-2	4	22-71-0	68	25-511	5	26-92	66
16-507	54	18-203	50	20-32	4	22-72-0	68	25-512	6	26-93	66
16-508	54	18-204	50	20-32B	4	22-73-0	68	25-515	5	26-94	66
16-509	54	18-234	50	20-33	5	22-74	68	258-10	87	26-95	66
16-51	53	18-240	50	20-33-2	4	23-350	5	258-11	87	26-96	66
16-511	54	18-242	50	20-33B	5	23-350B	5	258-13	87	26-99	64
16-512	54	18-243	50	20-37	5	23-38	5	258-14	87	27-826	95
16-517	54	18-244	50	20-37B	5	23-38B	5	258-15	87	27-827	95
16-518	54	18-245	50	20-4	4	23-41	5	258-17	87	27-828	95
16-519	54	18-246	50	20-4B	4	24-10	62	258-18	87	28-10	74
16-52	53	18-25	56	20-55	3	24-11	62	258-19	87	28-103	69
16-521	54	18-255	51	21-06	58	24-129	61	258-25	87	28-104	69
16-522	54	18-260	50	21-07	58	24-130	61	258-27	87	28-105	70
16-53	53	18-275	51	21-08	58	24-131	61	258-28	87	28-106	70
16-54	53	18-290	51	21-09	58	24-132	62	258-29	87	28-109	70
16-55	53	18-291	51	21-1	57	24-133	61	26-100	64	28-11	97
16-56	53	18-2919	52	21-10	57	24-134	61	26-101	64	28-110	69
16-57	53	18-292	51	21-100	58	24-135	61	26-102	64	28-111	69
16-58	53	18-360	52	21-104	58	24-136	61	26-121	66	28-112	69
16-6	53	18-40	56	21-11	58	24-137	61	26-122	66	28-113	69
16-61	54	18-491	52	21-12	58	24-138	62	26-24	6	28-114	69
16-62	54	18-55	57	21-13	58	24-140	62	26-25	6	28-115	69
16-63	54	18-60	56	21-14	57	24-141	62	26-26	6	28-118	69
16-64	54	18-65	56	21-18	58	24-143	62	26-27	6	28-119	69
16-65	54	18-75	57	21-19	58	24-144	62	26-36	3	28-12	97
16-68	54	18-9	56	21-2	57	24-145	61	26-40	6	28-120	69
16-69	54	18-90	56	21-20	58	24-146	61	26-43	6	28-121	69
16-7	53	18-A142	56	21-21	58	24-160	62	26-521	65	28-122	69
16-8	53	20-1614	5	21-25	55	24-161	62	26-522	65	28-123	75
16-81	59	20-1614	19	21-26	55	24-308	61	26-523	65	28-124	75
16-82	59	20-1615	5	21-27	55	24-351	61	26-57	66	28-125	75
16-83	59	20-1615	19	21-28	55	24-8003	62	26-58	66	28-128	75
16-86	59	20-1616	5	21-29	55	24-8004	63	26-60	66	28-130	75

Part No.	Page	Part No.	Page	Part No.	Page	Part No.	Page	Part No.	Page	Part No.	Page
28-131	75	28-211	75	28-904	78	36-134	93	41-307	36	42-110	35
28-132	75	28-212	75	300L-100	72	36-136	93	41-308	36	42-111	35
28-135	76	28-213	75	301095	88	36-144	93	41-309	36	42-112	35
28-137	76	28-214	75	304501	90	36-145	93	41-310	36	42-11K	38
28-139	75	28-215	75	304502	90	36-147	93	41-311	36	42-12	38
28-140	75	28-216	75	304503	90	36-148	93	41-312	36	42-121	38
28-141	76	28-219	78	304504	90	36-149	93	41-313	37	42-13	37
28-146	77	28-22	77	304505	90	36-202	96	41-314	37	42-14	38
28-147	77	28-220	78	304506	90	36-203	96	41-315	37	42-15	37
28-148	77	28-221	78	304507	90	36-204	96	41-317B	35	42-154	39
28-149	78	28-222	75	304508	90	36-205	96	41-318B	35	42-16	37
28-150	70	28-223	75	304509	90	36-73	93	41-319B	35	42-17	38
28-151	78	28-224	75	304510	90	36-74	93	41-320B	35	42-18	38
28-152	78	28-225	75	30-60	94	367L-150	72	41-321B	35	42-19	37
28-153	78	28-226	75	30-61	94	37-151	2	41-322B	35	42-20	42
28-154	78	28-227	75	30-62	94	37-1542	2	41-323B	35	42-200	39
28-155	78	28-228	75	30-63	94	37-1543	2	41-324B	35	42-201	39
28-156	78	28-229	75	30-64	94	37-1544	2	41-325B	35	42-202	39
28-160	70	28-23	77	30-66	94	37-357	2	41-326B	35	42-203	38
28-161	70	28-3	74	30-67	94	37-358	2	41-330	37	42-204	38
28-162	70	28-351	72	30-68	94	37-359	2	41-331	37	42-21	42
28-163	70	28-4	74	30-70	94	37-362	2	41-332	37	42-22	42
28-165	78	28-40	70	30-71	94	37-363	2	41-333	35	42-23	42
28-180	72	28-41	70	30-72	94	37-368	2	41-334	35	42-233	40
28-18	72	28-42	70	30-73	94	37-369	2	41-335	35	42-24	42
28-18	72	28-5	74	30-74	94	37-370	2	41-336	35	42-25	43
28-18	72	28-6	74	30-75	94	37-384	2	41-337	35	42-250	35
28-18	72	28-6931	79	30-76	94	37-601	2	41-338	35	42-26	37
28-18	72	28-6932	79	30-77	92	37-602	2	41-339	35	42-2653	44
28-18	72	28-6936	79	32-12	95	37-603	2	41-351	35	42-2654	44
28-18	72	28-6937	79	322L-100	72	37-800	2	41-359	37	42-2655	44
28-1 8	72	28-6938	79	32-36	95	37-805	2	41-539B	36	42-27	37
28-1 3	75	28-7	72	32-37	95	37-834	2	41-540B	36	42-30	43
28-194	75	28-7	71	32-38	95	37-844X	2	41-541B	36	42-300	39
28-195	75	28-7	71	32-39	95	390L-150	72	41-542B	36	42-301	39
28-196	75	28-7	71	32-60	95	400-1	90	41-869B	38	42-3088	35
28-197	75	28-7	71	32-61	95	400-2	90	41-878	38	42-3089	35
28-198	75	28-7	71	345L-150	72	400-21	90	42-03	40	42-3090	35
28-199	75	28-76	71	35-102	95	400-25	90	42-09	36	42-3091	35
28-2	74	28-79	71	36-100	95	400-3	90	420L-150	72	42-3092	35
28-200	75	28-80	71	36-101	95	40-11	91	42-10	38	42-3093	35
28-201	75	28-81	77	36-104	95	40-114	91	42-102	35	42-31	43
28-202	75	28-82	77	36-105	95	40-15	91	42-103	35	42-32	36
28-203	75	28-83	77	36-106	95	40-20	91	42-104	35	42-327	40
28-204	75	28-84	77	36-107	95	40-225	91	42-105	35	42-328	40
28-205	75	28-86	71	36-108	95	40-254	91	42-106	35	42-33	43
28-206	75	28-87	71	36-124	93	40-27	91	42-107	35	42-34	43
28-207	75	28-89	71	36-125	93	40-30	91	42-108	35	42-349	35
28-208	75	28-901	78	36-129	93	40-6002	91	42-109	35	42-349-05B	37
28-209	75	28-902	78	36-130	93	40-65	91	42-10K	38	42-35	45
28-210	75	28-903	78	36-133	93	41-306	36	42-11	38	42-350	35



Part No.	Page	Part No.	Page	Part No.	Page	Part No.	Page	Part No.	Page	Part No.	Page
42-36	45	50-043	84	50-194	86	52-204	81	BA-1010UN	90	RGA-34	89
42-37	46	50-044	84	50-201	86	52-235	81	BB27	97	RGA-35	89
42-401	39	50-054	84	50-206	86	52-236	81	BB32	97	RGA-36	89
42-402	39	50-065	84	50-217	86	52-238	81	FF01	60	R-GEM	72
42-403	37	50-066	84	50-218	86	52-450	81	FF02	60	SC-45	54
42-404	37	50-068	84	50-219	86	52-500	81	FF03	60	SC-75	54
42-405	37	50-070	84	50-222	86	52-550	81	H116-6	8	SD-17	73
42-406	39	50-072	84	50-228	86	52-551	81	H222-1	51	SD-18	73
42-407	39	50-073	84	50-231	86	52-552	81	HN-1	73	SD-19	73
42-408	39	50-074	84	50-234	86	52-556	81	HN-12	73	SD-20	73
42-619	40	50-076	84	50-235	86	52-570	82	HN-2	73	SD-22	73
42-620	40	50-080	84	50-240	86	52-571	82	HN-28	73	SD-23	73
42-65	38	50-083	84	50-254	86	52-601	81	HN-29	73	SD-24	73
42-66	38	50-086	84	50-707	86	52-602	82	HN-38	73	SD-27	73
4-350	2	50-087	84	510-10	87	52-650	82	HN-4	73	SD-530	73
4-353	2	50-090	84	510-11	87	53-105	67	HN-7	73	SS-10	73
44-500	96	50-100	85	51-105	83	53-114	67	HS-13	73	SS-16	73
44-510	96	50-102	85	51-114	83	53-351	67	HS-14	73	SS-17	73
44-8607	97	50-104	85	51-116	83	53-65	67	HS-15	73	SS-18	73
44-9507	97	50-105	85	5-114	3	53-70	67	HS-16	73	SS-19	73
46-251	41	50-108	85	5-115	3	53-71	67	HS-17	73	SS-20	73
46-252	41	50-109	85	5-116	3	56-10	69	HS-20	73	SS-6	73
46-253	41	50-110	85	5-117	3	56-11	69	HS-21	73	ST-12	73
46-254	41	50-111	85	5-118	3	56-12	69	HS-22	73	WE-829	2
46-353	41	50-114	85	51-237	83	56-19	69	HS-25	73	WE-838	2
46-360	41	50-123	85	51-250	83	56-20	69	HS-16	73	WE-848	2
46-361	41	50-124	85	51-337	83	56-21	69	KC308M	28		
46-376	41	50-126	85	51-351	83	56-22	69	LK-1	90		
47-8149	97	50-127	85	51-352	83	56-23	69	LK-2	90		
47-8150	97	50-128	85	5-145	3	62-500	6	LP1000	44		
47-8865	97	50-136	85	51-54	83	62-507	6	LP2000	44		
47-8866	97	50-137	85	51-70	83	64-4	6	LP3000	44		
48-81	92	50-138	85	51-83	83	64-5	6	LP4000	44		
48-83	92	50-140	85	51-85	83	64-7	6	MA-10	88		
48-84	92	50-142	85	52-1000	82	8-105	3	MA-12	88		
48-86	92	50-145	85	52-130	80	8-25	3	MA-14	88		
48-87	92	50-147	85	52-140	80	8-35	3	MA-15	88		
48-88	92	50-150	85	52-141	80	8-45	3	MA-16	88		
48-90	92	50-154	85	52-142	80	8-55	3	MA-17	88		
48-91	92	50-156	85	52-143	80	8-65	3	MA-18	88		
48-92	92	50-157	85	52-144	80	8-75	3	MA-19	88		
48-93	92	50-158	86	52-145	80	8-85	3	MA-20	88		
50-009	84	50-166	86	52-172	80	8-95	3	NN-507	73		
50-010	84	50-167	86	52-173	80	A3-0402	90	PBB32	97		
50-011	84	50-173	86	52-174	80	A3-0502	90	R-202	72		
50-025	84	50-175	86	52-18	58	A3-0602	90	R-308	72		
50-033	84	50-182	86	52-186	80	BA-0375UN	90	R-350L	72		
50-035	84	50-183	86	52-19	58	BA-0376UN	90	R-350S	72		
50-037	84	50-185	86	52-200	82	BA-0377UN	90	R351	72		
50-041	84	50-186	86	52-202	80	BA-0608N	90	RGA-31	89		
50-042	84	50-189	86	52-203	81	BA-08N10U	90	RGA-32	89		
								RGA-33	89		



## Redline shirts



Hardiman Auto Supplies Pty Ltd  
also distributes the following product lines:

**303**  
PROTECTANT

**Flex-a-lite**  
Leading the Way  
in Cooling Technology

**Holley**  
Lumenition

**EDGE**  
Silicone Ignition Leads

**SMITHS**  
DAVIES, CRAIG

**High Energy**

**SPEEDFLOW**

**10+**  
OCTANE  
BOOST

**pricol**  
Quality. Automatic. Advancing.

**TAYLOR**  
**VERTEX**

**WEBER**

**Yella Terra**  
HI PERFORMANCE ENGINE PARTS

# Redline

PERFORMANCE



**Hardiman Auto Supplies Pty Ltd**

ACN 114 752 564 ABN 22 114 752 564

9 Bullecourt Avenue, Milperra NSW 2214, PO Box 63, Panania NSW 2213

Telephone: (02) 8723 8888 Facsimile: (02) 9771 2176 Email: [sales@redlineauto.com.au](mailto:sales@redlineauto.com.au) Web: [www.redlineauto.com.au](http://www.redlineauto.com.au)

**DISTRIBUTED BY**

