



AUTOPARTS

Fuel Systems

ILLUSTRATED BUYER'S GUIDE



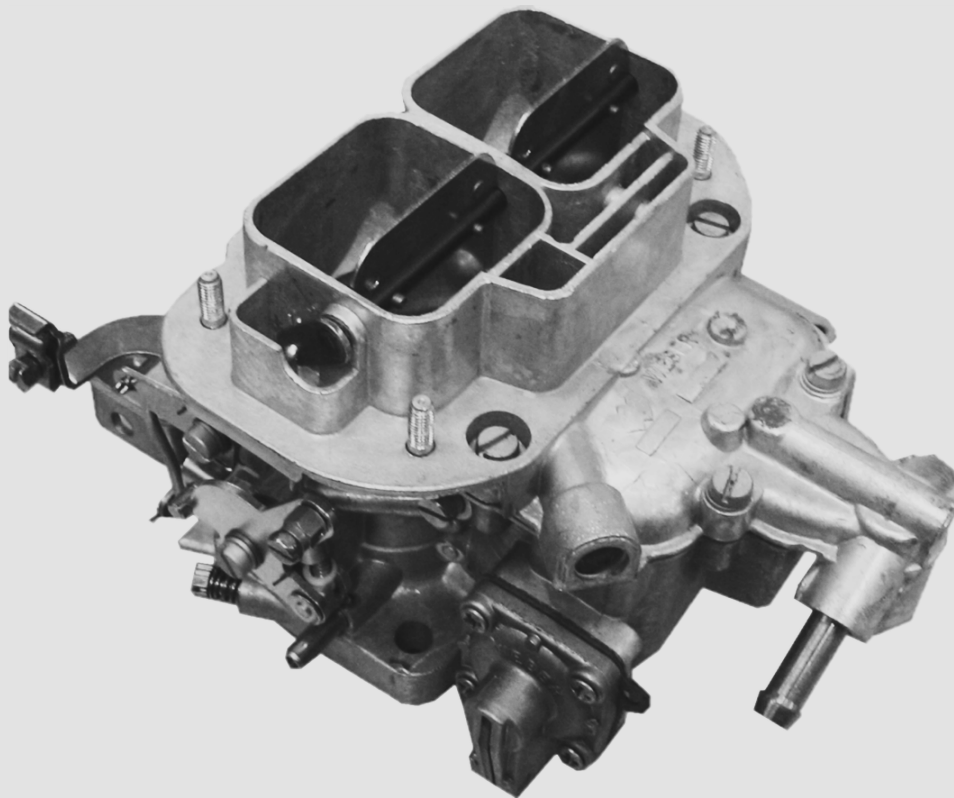









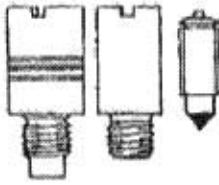





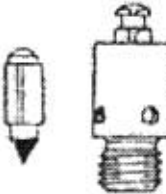

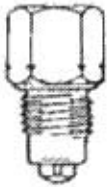

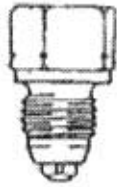
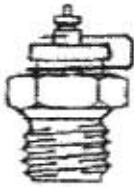
CARBURETTOR REPAIR KITS • CARBURETTOR KIT IDENTIFICATION
CARBURETTOR COMPONENTS • MANUAL CHOKE CONVERSIONS
PCV VALVES • FLEXIBLE AIR DUCTING

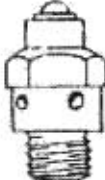
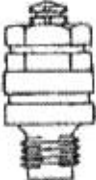
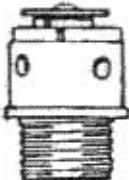
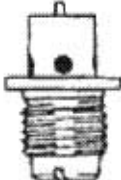

LOCAL SERVICE. WORLD-CLASS QUALITY.

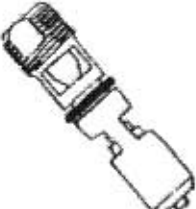

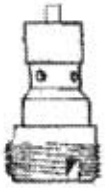
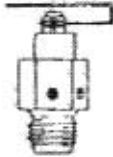







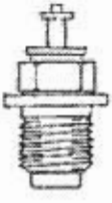

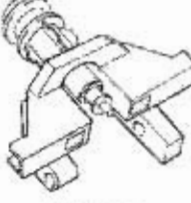
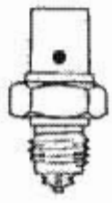

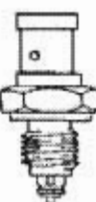
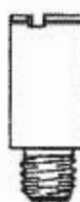
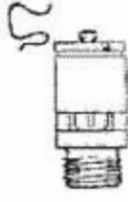
Illustrations

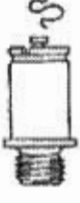
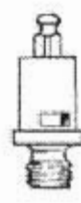
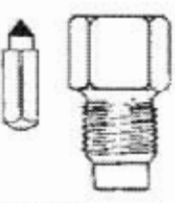
Needle & Seats

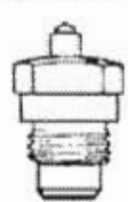
 <p>AN-100NS</p>	 <p>AN-101NS</p>	 <p>AN-103NS</p>	 <p>AN-106NS</p>	 <p>AN-107NS</p>
 <p>AN-108NS</p>	 <p>AN-109NS</p>	 <p>AN-113NS</p>	 <p>AN-116NS</p>	 <p>AN-121NS</p>
 <p>AN-124NS</p>	 <p>CA-150NS</p>	 <p>2 X N/Seats supplied CA-151NS</p>	 <p>CA-152NS</p>	 <p>1.7mm Orifice CD-200NS</p>
 <p>2.0mm Orifice CD-201NS</p>	 <p>CD-202NS</p>	 <p>DE-250NS</p>	 <p>FD-300NS</p>	 <p>FD-301NS</p>
 <p>Primary FD-304NS</p>	 <p>Primary FD-305NS</p>	 <p>HT-412NS</p>	 <p>3/8-32 Thread, OE 6-504 HY-350NS</p>	 <p>7/16" oversize thread (use O/size tip THY-001) HY-350NSX</p>
 <p>HY-360NS</p>	 <p>OE 6-514 HY-362NS</p>	 <p>Primary OE 6-516, .097" orifice HY-363NS Secondary, OE 6-510, .110 orifice HY-368NS</p>	 <p>OE 6-515, .130 orifice steel tip HY-370NS</p>	 <p>KN-450NS</p>



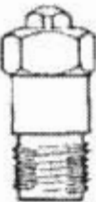







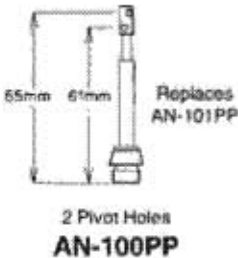

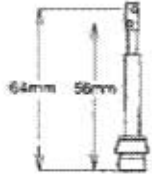
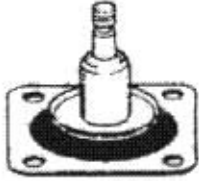

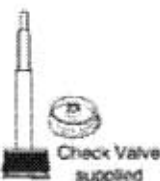





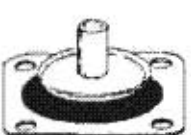

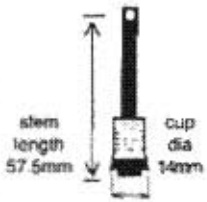
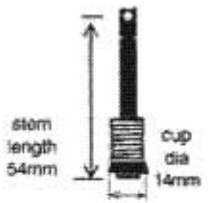
Illustrations

Needle & Seats

 <p>KN-452NS</p>	 <p>MS-500NS</p>	 <p>MS-505NS</p>	 <p>Nylon Body MS-511NS</p>	 <p>NK-550NS</p>
 <p>NK-554NS</p>	 <p>NK-563NS</p>	 <p>NK-566NS</p>	 <p>NK-572NS</p>	 <p>.125" Orifice RT-601NS</p>
 <p>.135" Orifice RT-602NS</p>	 <p>RT-604NS</p>	 <p>RT-605NS</p>	 <p>SB-650NS Standard SB-651NS .101" Orifice</p>	 <p>SU-750NS</p>
 <p>Spring Loaded Needle</p> <p>Orifice SX-701NS 1.20mm SX-710NS 1.75mm SX-700NS 2.00mm</p>	 <p>Spring Loaded needle 1.5mm Orifice SX-703NS</p>	 <p>WE-800NS</p>	 <p>Orifice WE-805NS150 1.20mm WE-805NS175 1.75mm WE-805NS200 2.00mm WE-805NS250 2.50mm</p>	 <p>3.0mm" Orifice WE-848NS</p>
 <p>ZE-852NS</p>	 <p>Spring Loaded Needle 1.8mm" Orifice ZE-853NS</p>	 <p>2.5mm" Orifice ZE-864NS</p>		





















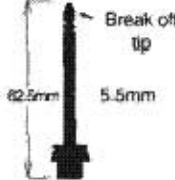

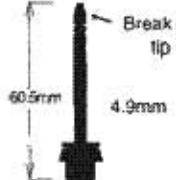

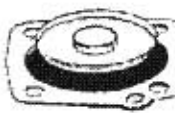

Illustrations

Pump Plungers / Diaphragms

<p>DIMENSIONS SHOWN Diaphragm Holes- centre to centre Stem Diameter Washer Diameters: Upper /Lower</p>	<p>PART NUMBER SUFFIX AD-Auxiliary Diaphragm ACD-Air cond. Diaph. ED-Economy Diaphragm PP-Economy Diaphragm PP-Pump Plunger PV-Power Valve VV-Vent Valve</p>		 <p>AN-102PP</p>	 <p>AN-103PP</p>
 <p>AN-107PP</p>	 <p>AN-121PP</p>	 <p>CA-150PP</p>	 <p>CA-151PP</p>	 <p>CA-152PP</p>
 <p>CA-154PP</p>	 <p>CA-157PP</p>	 <p>CD-200PP</p>	 <p>CD-201PP</p>	 <p>CD-205ED</p>
 <p>DE-250PP</p>	 <p>FD-300PP</p>	 <p>FD-301PP</p>	 <p>FD-304PP</p>	 <p>HT-401PP</p>
 <p>HT-412PP</p>	 <p>HT-420PP</p>	 <p>HY-350PP</p>	 <p>HY-359PP</p>	 <p>HY-360PP</p>
 <p>KN-450PP</p>	 <p>KN-458PV</p>	 <p>MS-500PP</p>	 <p>MS-505ED</p>	 <p>MS-505MCV</p>

Illustrations

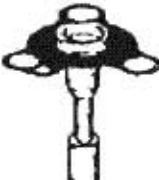
Pump Plungers / Diaphragms

 <p>MS-505VV</p>	 <p>MS-511VV</p>	 <p>NK-550PP</p>	 <p>NK-556PP</p>	 <p>NK-566PP</p>
 <p>RT-601PP</p>	 <p>RT-602PP</p>	 <p>Bucket Only RT-604PP</p>	 <p>RT-604PPA</p>	 <p>RT-604PPL</p>
 <p>SB-651PP</p>	 <p>Break off tip 62.5mm 5.5mm SB-652PP</p>	 <p>SB-653PP</p>	 <p>Break off tip 60.5mm 4.9mm Replaces SB-654PP SB-655PP</p>	 <p>Centre to centre 27mm Stem length: 12mm Washer dia. 16/22mm SX-700PP</p>
 <p>Centre to centre 26mm Stem length: 12.25mm Washer dia. 13/22mm SX-701PP</p>	 <p>Stem length: 10.75mm Washer dia. 22/22mm SX-703PP</p>	 <p>Stem length: 14mm Washer dia. 22/22mm SX-705PP</p>	<p>47407-115</p>  <p>Auxiliary Diaphragm WE-800AD</p>	<p>47407-048</p>  <p>Centre to centre 26mm Stem length: 12.25mm Washer dia. 25/25mm WE-800PP</p>
<p>47407-233</p>  <p>WE-801PV</p>	 <p>Centre to centre 26mm Stem length: 12.5mm Washer dia. 22/22mm HY-358PP use WE-802PP</p>	<p>47407-183</p>  <p>WE-844AD</p>	<p>47407-001</p>  <p>Air conditioner diaphragm WE-844ACD</p>	<p>47407-146</p>  <p>centre to centre 28mm WE-844PP</p>
<p>47407-182, 47407-250</p>  <p>Power Valve Diaphragm WE-844PV</p>	 <p>ZE-850PV</p>	 <p>ZE-851PV</p>	 <p>Centre to centre 24mm Stem length: 8.5mm Washer dia. 16/16mm ZE-853PP</p>	















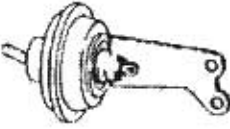

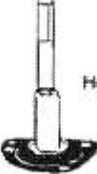

Illustrations

Vacuum Secondary Diaphragms

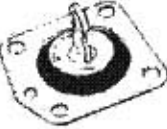
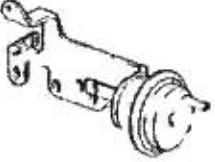
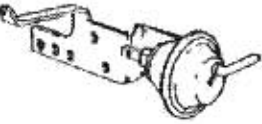
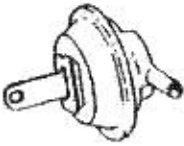
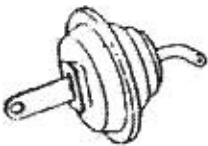
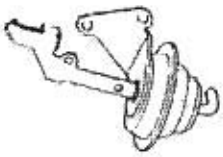
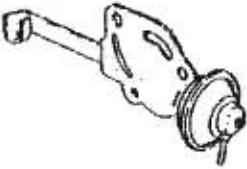
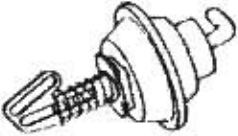
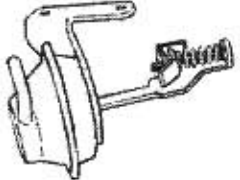
STEM LENGTH (A) MEASUREMENT		Part No. Stem Length OE Part Number			
		AN-100SD 34mm	21669-44100		
		AN-103SD 70mm	21669-61020		
		AN-111SD 50mm	Asan		
		AN-111SDN 50mm	Nikki 21173-31620		
		AN-113SD 36mm			
		AN-126SD 32mm			
		Bent Stem replaced by straight stem			
21488-45070 AN-102SD	21669-61100 AN-105SD	21669-34080, 21669-34371 AN-108SD		Nikki 21173-36120 (For Asan use AN-111SD) AN-111SDN	HT-423SD
Part No. Stem Length OE Part Number		Governor 2 & 4 barrel Holley on International Harvester	Part No. Stem length O.E. No.		
HT-401SD 40mm E301-233-560		HY-365GD	135-2 47.5mm 135-2		
NK-566SD 33mm 16093-B-8500, 6093-A-3510			135-3 50.5mm 135-3	Chrysler USA, Holley 4160.	
NK-566SDL TBA			HYP-58 51.5mm 135-4	HY-391SD	
MS-500SD	MS-503SD	MS-505SD	MS-511SD	222 23.3770, 16093.36702 NK-550SD	
Note: stem angle in relation to vacuum passage					
	Stem Length 38mm NK-556SD	Fits Solex & Zenith ZE-850SD			

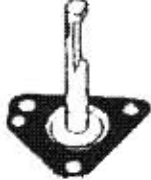

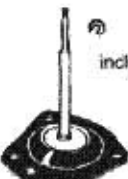
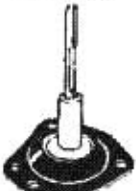







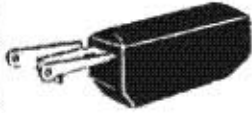





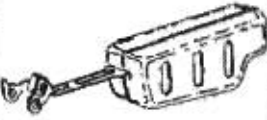

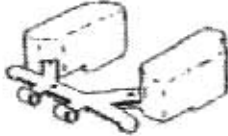



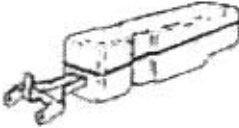
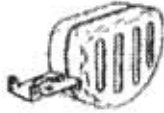

Illustrations

Choke Pull-Off Diaphragms

 <p>Asian only AN-111CPA</p>	 <p>Some models may require this bush to gain length AN-121CP</p>	 <p>O.E. MC9A548A CA-151CP</p>	 <p>O.E. XC9JS49A CA-151CPA</p>	 <p>CA-156CP</p>
 <p>CA-157CP</p>	 <p>FD-301CP</p>	 <p>Holley only HYP-54</p>	 <p>Same as MS-511CP MS-500CP</p>	 <p>MS-500CPL</p>
 <p>MS-505CP</p>	 <p>MS-513CP</p>	 <p>MS-513CPA</p>	 <p>GMH 8.94214412.0 8.94204421.0 NK-563CP</p>	 <p>NK-566CP</p>
 <p>Lato series II & III Bluebird NK-566CPL</p>	 <p>RT-601CP</p>	 <p>GMH 7040100 RT-602CP</p>	 <p>RT-603CP</p>	 <p>RT-604CP</p>
 <p>RT-606CP</p>	 <p>2-4832 RT-609CP</p>	 <p>O.E. 387253 SB-651CP</p>	 <p>Also fits mikuni solex as fitted to Mitsubishi (MS-S02) SX-700CP</p>	 <p>SX-701CP</p>
 <p>SX-703CP</p>	 <p>47407-162 includes clip WE-800CP</p>	 <p>47407-056 WE-803CP</p>	 <p>47407-226 WE-844CP</p>	 <p>ZE-850CP</p>





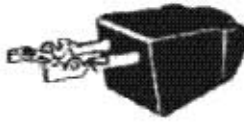
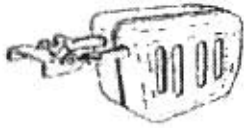







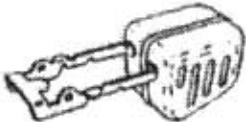





Illustrations

Floats

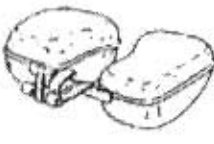





<p>FLOAT PART NUMBER SUFFIX FT - Nitrophenyl FTB - Brass M - Main A - Auxilliary NOTE: Do Not use Brass Floats with LPG (Normal weight of float shown in brackets)</p>	 (8.0g) AN-100FT	 (9.0g) AN-111FT	 (8.0g) AN-113FT	 (10.5g) AN-121FT
 (16.0g) CA-150FT	 (7.5g) CA-151FT	 (10.5g) CA-151FTB	 (7.5g) CA-152FT	 (14.0g Plastic) CD-200FT
 (19.5g) FD-301FT	 (15.0g) FD-304FT	 (12.0g) HT-401FT	 (13.5g) HT-414FT	 (11.0g) Also replaces HY-353FT HY-350FT
 (16.5g) Also replaces HY-363FTB HY-352FT	 (15.5g) Also replaces HY-350FT HY-353FT	 (10.5g) HY-358FT	 (13.0g) HY-362FTB	 (17.5g) Also replaces HY-362FT HY-363FTB
 (12.0g) HY-364FT	KN-455FTM  (10g) KN-455FTA	 (6.5g) MS-500FT Complete with needle & seat MS-503FT	 (6.0g) MS-502FT	 (7.0g) MS-505FT
 (11.0g) NK-550FT	 (12.0g) NK-554FT	 (11.0g) NK-566FT	 (7.0g) RT-601FT	 (8.0g) RT-601FTB

Illustrations

Floats

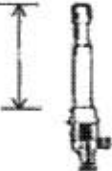
 (8.2g) RT-602FT	 (8.5g) RT-602FTB	 (6.5g) RT-603FT	 (7.5g) RT-603FTB	 (8.0g) RT-604FT
 (5.0g) Camira only RT-604FTC	 (10.0g) RT-605FTB	21-738A  (7.5g) RT-609FT	382537  (12.0g) SB-650FT	385154  (14.0g) SB-651FT
WZX1300  (7.5g) Plastic SU-750FT	WZX1509  (6.5g) OE WZX1509 Plastic SU-760FTLH	WZX1510  (6.5g) OE WZX1510 Plastic SU-760FTRH	41030.019  (16.0g) Brass WE-800FT	41030.022  (16.0g) WE-800FTN
41030.004  (23.0g) WE-805FT	41030.012  (13.0g) WE-813FT	41015.004  (11.0g) WE-844FT	41020.005  (16.0g) Replaces WE-844FTM WE-844FTN	

SU Main Jets (with reference to Repair Kits)

CARBURETTOR MODEL	REPAIR KIT	MAIN JET SIZE	MAIN JET PART NO.			
H Series	SU-765	0.090"	159-001A	 H Series	 HD Series	 HIF Series
HD Series	SU-767	0.100"	159-002A			
	SU-751	0.090"	In Kit Only			
	SU-763	0.100"	159-005A			
HS2,HS4,HS6	SU-764	0.125"	159-003A	 HS8, HS4C Collar Type	 HS Series	 HS Capstat
	SU-750	0.090"	159-008A			
	SU-754	0.100"	159-010A			
HS4C,HS8	SU-774	0.090"	159-009A			
	SU-776	0.100"	159-011A			
	SU-770	0.100"	159-011A			
HS CAPSTAT	SU-768	0.090"	159-015A			
	SU-769	0.100"	159-016A			
HIF4, HIF6	SU-755	0.099"	In Kit Only			
	SU-759	0.090"	159-004A			
	SU-760	0.100"	159-006A			
HIF7	SU-771	0.100"	159-014A			

* Comprises Main Jet assembly as illustrated, plus washers, fuel transfer tube, barb fitting and instruction sheet

Illustrations

Carburettor Gaskets - Holley

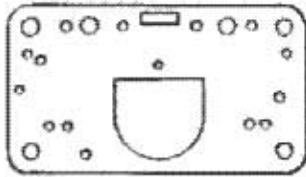

OE 108-29
HYP-46

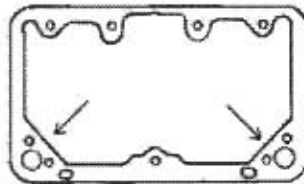

Squarebore OE 108-33
HYP-47

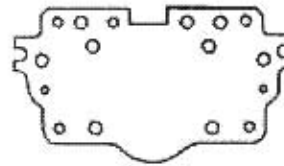

OE 108-13
HYP-48

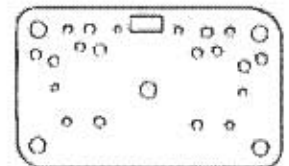

OE 108-30
HYP-49

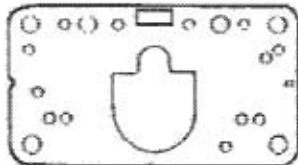

OE 108-35
HYP-52

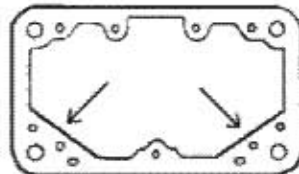

Spreadbore OE 108-32
HYP-53

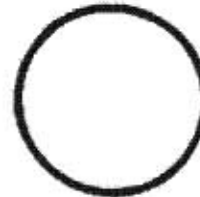

Air filter gasket, Holley 2 & 4 barrel,
Rochester Q/Jet,
Carter T/Quad, OE. 108-4
HYP-57

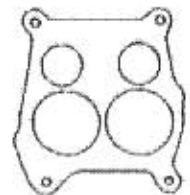

Holley Spreadbore, Rochester Q/Jet
HYP-62

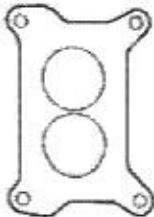

AutoLite/Ford, Holley 2300 Series
350/500cfm OE 108-9
HYP-63

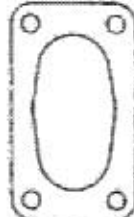

Weber DGV Series, Holley 5200
HYP-66

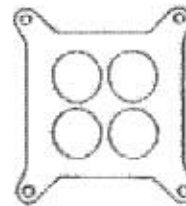

Holley Squarebore, AutoLite/Ford
HYP-67

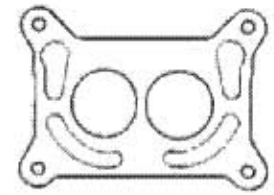

20-0104

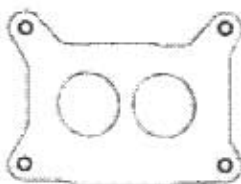

Motorcraft 2100
20-2267

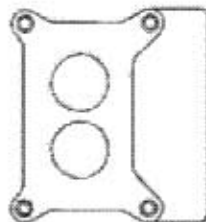

Heat Insulator, 2300 2-barrel,
1-1/2" bore OE 108-52
20-2422A

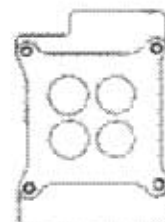

Heat Insulator, 4150/4160 4-barrel,
1-1/2" bore OE 108-53
20-2426A

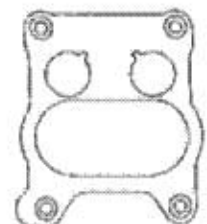

Spreadbore Insulator, 11/64" Thick
20-2268A

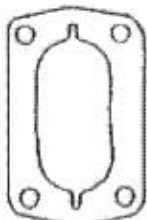

Flange Gasket, WW Stromberg
20-1065 Thickness 8mm
Heat insulator, WW Stromberg
20-1652 Thickness 8.2mm

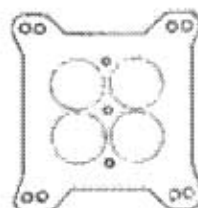

Carter / Rochester
20-0302





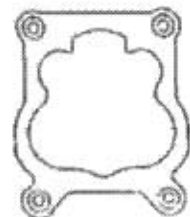







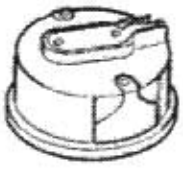











5mm Insulator, Holley / Rochester
20-0401



Spreadbore Insulator 1/4" Thick
20-2269A

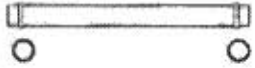
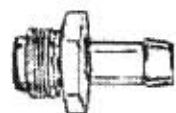





















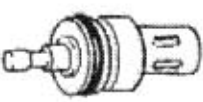

Illustrations

Rebuilder Parts - Miscellaneous

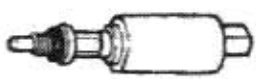
AISAN	CARTER			HOLLEY
 Idle Solenoid - Jet Type AN-107IS	 Carburettor Base water heated and EGR adaptors, refer page 9 CA-150EAK	 Electric Choke Housing CA-151EC	 Hitachi Power Valve HTJ-040 orifice size .040" HTJ-045 orifice size .045" HTJ-050 orifice size .050" HTJ-060 orifice size .060"	 Choke Shaft Screws HYP-4/8
 Power Valves All sizes in increments of 10 HYP-20 & HYP-25 to 105	 Power Valve, DE 125-1 Weber DFV, DGAV Holley 5200 HYP-56	 Needle & Seat Locknut & Washer HYP-61	 Choke Rod HYP-203	 Throttle Connecting Rod HYP-205
 Holley Choke Rod HYP-252	 Throttle Connecting Rod HYP-426	 Choke Spring-Light Reduces tension on valve to prevent flooding & rich mixture HYP-637	 HOLLEY TAP Oversize N/Seat tap for HY-350NSX THY-001	 Pump Cams Assortment of Seven profiles 20-12
 Secondary Diaphragm Spring Kit Assortment of Seven 20-13	 Throttle Disc Screws 26-02/8	 Idle Mixture Screw & Cork Seal 20-04/2	 Pump Housing Screws 26-4/8	 Throttle Body Screws 26-7/4
 Fuel Bowl Screws Part No. Length Model 26-8/4 1-7/8 4160-4175 26-6/4 2-1/2 4150-4165 26-10/4 2" 4165 26-11/4 1-3/8 4175	 Pump Discharge Nozzle Screw 26-12	 Fuel Bowl Sight Plug & Gasket 26-13/2	 External Transfer Tubes Including 'O' Rings Part No. Length 26-19 6-9/32" 26-20 5-31/32" 26-22 7-5/32"	 Inlet Fitting 5/16" Hose, 9/16-24 Thread 26-24
 Banjo Inlet Fitting 5/16" Hose, 9/16-24 Thread 26-25	 Inverted Flare Inlet Fittings 26-26 3/8" Line 26-27 5/16" Line	 Oversize (repair) Inlet Fitting with Cutter-thread & washer 26-26X 3/8" Line 26-27X 5/16" Line	 Power Valve, Blank 26-36	 Bronze Inlet Filter Holley & Rochester 30-404

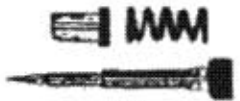

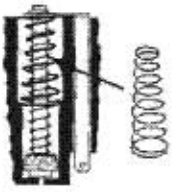



Illustrations

Rebuilder Parts - Miscellaneous

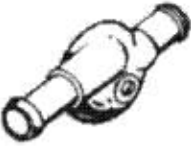

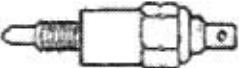

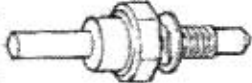
 <p>Paper Inlet Filter Holley & Rochester 30-408</p>	 <p>Inlet Filter, Rochester 30-409</p>	 <p>Inlet Filter Carter 30-414</p>	 <p>Manual Choke Conversion Fits Holley 2300, 4150, 4160 45-225</p>	 <p>Pump Discharge Nozzles 121-25 (0.025") 121-28 (0.028") 121-31 (0.031")</p>
 <p>Pump Discharge Nozzles 121-125 (0.025") 121-128 (0.028")</p>	 <p>Standard main Jets All sizes in increments of 1 122-45/2 to 122-100/2</p>	 <p>Check Valve 169-13</p>	 <p>Plug, Idle Jet 5-146</p>	<p>MIKUNI SOLEX</p>  <p>Idle Mixture Screw Late MS-500ISE</p>
 <p>Idle Mixture Screw Late MS-500ISL</p>	 <p>Nylon Gear Bracket Assembly suits late plastic body carburettor MS-511CPB</p>	 <p>Choke Wax Pellet Die cast carburettor MS-500WP</p>	 <p>Hot water tube fitting MS-505HT</p>	 <p>Choke Wax Pellet Plastic carburettor MS-505WP</p>
 <p>Choke Wax Pellet Die cast carburettor MSP-001</p>	 <p>Packet of 5, Rod & Link Bush (Fits Solex & most Jap carbs) MSP-002/5</p>	<p>NIKKI</p>  <p>Idle Solenoid - Plunger Type NK-566IS</p>	<p>ROCHESTER</p>  <p>Electric Choke RT-603EC</p>	 <p>Idle Solenoid - Jet Type RT-604IS</p>
 <p>Variable Idle Mixture Screw, Repair Kit RTP-001A</p>	<p>SOLEX</p>  <p>PICT Idle Screw Repair Kit SXP-053</p>	<p>STROMBERG</p>  <p>Adjustable Main Jet SBP-039</p>	 <p>Pump Link & Lever Kit SBP-040</p>	 <p>Pump & Linkage lost motion prevention spring SBP-043</p>
 <p>Stromberg Idle Mixture Screw 159-12A</p>	 <p>Late Stromberg Idle Mixture Screw 159-13A</p>			

Illustrations





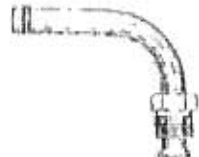
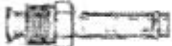



Rebuilder Parts - Miscellaneous

<p>WEBER 32444-005</p>  <p>OGAV Choke Housing WE-800CH</p>	<p>57804-333</p>  <p>Electric Choke Housing WE-844EC</p>	 <p>ADM Power Valve Assembly WE-844PVA</p>	<p>43931-060</p>  <p>XE Electric Choke Solenoid Incorporates Jet WE-844IS</p>	<p>43840-024</p>  <p>XF Idle Cut-Off Solenoid, Plunger Type WE-844ISP</p>
<p>84150-004</p>  <p>XF Vac. Transfer Port WE-844ISS</p>	<p>43929-070</p>  <p>XF Vac. 2-stage Idle Jet WE-844ISV</p>		<p>WEBER (LADA)</p>  <p>Idle Solenoid - Jet Type #45 XA-104IS</p>	 <p>Idle Solenoid - Jet Type XA-105IS</p>

Linkage Parts & Fuel Fittings

<p>TANK VALVES Electric dual fuel tank Change - Over Valves and Fuel Security Shut- off Valve</p>	 <p>Dual Tank Change - over Valve without tank return</p> <p>TSV-3K</p>	 <p>Dual Tank Change - Over Valve with tank return, to suit EFI vehicles</p> <p>TSV-6K</p>	 <p>Fuel Security Shut - off Valve</p> <p>SV-7K</p>	 <p>Fuel Security Shut - off Kit, SV-503K</p>
 <p>Linkage Ball, 1/4" 20-02</p>	 <p>Throttle Return Spring 75mm 20-03</p>	 <p>Throttle Return Spring 115mm 20-04</p>	 <p>Vacuum Plugs</p> <p>26-001/10 1/8" (10 off) 26-014/10 3/16" (10 off) 26-15/5 1/4" (5 off) 26-17/5 5/16" (5 off) 26-16/5 3/16" (5 off) 26-002/5 1/2" (5 off)</p>	 <p>10 Assorted Vacuum Plugs: 1/8", 3/16", 1/4", 5/16", 3/8", 1/2" HYP-59</p>
 <p>Nylon "T" Pieces</p> <p>26-00 1/4" T 26-01 5/16" T 26-02 3/8" T</p>	 <p>Nylon Tube Fittings</p> <p>26-03 1/8 BSP x 3/16" 26-05 1/8 BSP x 5/16"</p>	 <p>1/8 BSP Nylon Plug 26-07</p>	 <p>3/16" Vacuum T Piece 26-32</p>	 <p>Steel Tube Fitting 90 degree, inverted Flare</p> <p>26-44 1/4BSP-5/16" Hose 26-46 5/8" BSP-3/8" Hose</p>
 <p>Steel Tube Fitting inverted Flare</p> <p>26-45 1/2" Thread 5/16" Hose 26-47 5/8" Thread 3/8" Hose</p>	 <p>Steel T piece 5/16" 26-48</p>	 <p>Check balls, Steel</p> <p>116-1 1/8" 16-2 5/32" 116-3 3/16"</p>		









Carburettor Repair Kits & Parts

 Make & Model	 Eng Size	 Year	 Carb. Model	Type of carb, No of barrels No. of carbs	 Repair Kit	 Needle & Seat	 Pump Plunger	 Choke Pull Off
ALFA ROMEO & ALFA SUD								
Alfa								
1300	1290	66-69	32 PBI	SL1	SX-719	SX-700NS		
33	1490	84-85	32 DIR	W2	WE-811A	WE-800NS	WE-802PP	
33	1490	85 on	36 IDF	W2x2	WE-8081	WE-800NS		
33	1717	87 on	40 IDF	W2x2	WE-8081	WE-800NS		
Giulia	1290-1570	65-70	32 PAIA	SL2	SX-7071	SX-700NS		
Giulia	1779-1962	70 on	40DHLA	D2x2	DE-250	DE-250NS	DE-250PP	
Giulia	1779-1962	70 on	40DDH	SL2x2	SX-702	SX-702NS		
Giulia	1779-1962	70 on	DCOE	W2x2	WE-805	WE-805NS*		
Sprint	2585	65-68	44 PHH	SL2x2	MS-509	SX-700NS		
Alfasud								
Coupe	1490	79-83	32DATRA	W2	WE-832A	WE-800NS	WE-800PP	WE-832CP
Ti Coupe	1186-1490	72-83	32 DIR	W2	WE-811A	WE-800NS	WE-802PP	WE-832CP
Ti Hatch	1490	83-84	36 IDF	W2x2	WE-8081	WE-800NS		
Alfetta								
2000	1962	3/78-80	40DCOE	W2x2	WE-805	WE-805NS*		
GT Coupe	1779	10/75-76	40DCOE	W2x2	WE-805	WE-805NS*		
GTV6	1750	74-78	40DHLA	D2x2	DE-250	DE-250NS	DE-250PP	
GTV6	1750	74-78	40ADDHE	SL2x2	SX-702	SX-702NS		
GTV6	1750	74-78	40DOCE	W2x2	WE-805	WE-805NS*		
Berlina								
1750	1779	6/68-72	40DCOE	W2x2	WE-805	WE-805NS*		
2000	1962	6/72-76	28/36DCD	W2	WE-804	WE-800NS		
2600	2585		32PAIA	SL2x2	SX-7071	SX-700NS		
Giulietta								
	1779	81-82	40DHLA	D2x2	DE-250	DE-250NS	DE-250PP	
	1779	81-82	40DOCE	W2x2	WE-805	WE-805NS*		
GT Veloce								
1750	1779	68-77	40DCOE	W2x2	WE-805	WE-805NS*		
Spider								
2600	2585	65-68	45DCOE	W2x3	WE-805	WE-805NS*		
A.M.C. JEEP & RAMBLER 4 Cylinder								
Cherokee								
CJ7,8	2474	80-83	E2S3	R2	RT-610			
Jeep								
4-134	134	65-71	YF4002	C1	CA-158			
4-134	134	65-71		C1	CA-175			
4-73,75,134	134	50-67	YF2392	C1	CA-169			
Military Kaiser								
		40-52	WO	C1	CA-164			
Willys Jeep								
		40-52	WO	C1	CA-164			
A.M.C JEEP & RAMBLER 6 Cylinder								
Cherokee & Renegade								
CJ6-7	4228	77-83	BBD 1"	C2	CA-160	CA-150NS		
CJ6-7	4228	77-85	YF	C1	CA-178			
Hornet AMX								
	3802-4229	70-5/76	RBS	C1	CA-177			
Jeep 226ci								
	226ci	54-56	WCD	C2	CA-161			
	226ci	52-57	YF	C1	CA-169			
	226ci	66-71	RBS	C1	CA-177			

Notes:

* WE-805NS is available in different sizes, refer to page 2

Carburettor Repair Kits & Parts









 Make & Model	 Eng Size	 Year	 Carb. Model	Type of carb, No. of barrels No. of carbs	 Repair Kit	 Needle & Seat	 Pump Plunger	 Choke Pull Off
A.M.C JEEP & RAMBLER 6 Cylinder (Continued)								
Renegade	226ci	71-72	YF	C1	CA-158			
J10-J20	4228	11/82-4/85	BBD	C2	CA-160	CA-150NS		
A.M.C. JEEP & RAMBLER 8 Cylinder								
Cherokee	5899	78-79	4350	F4	FD-305	see note (5)		
J20	5899	4/82-4/85	4350	F4	FD-305	see note (5)		
Sportsman	5899	68 on	2150	F2	FD-306A	FD-301NS		
Classic								
660	4704	2/64-5/67	4300	F4	FD-304	see note (5)	FD-304PP	
Javelin	5620-6510	69-73	4300	F4	FD-304	see note (5)	FD-304PP	
Matador	5899	11/71-6/78	2100	F2	FD-301	FD-301NS	FD-301PP	FD301CP
Rebel								
770	4753,5620	5/67-69		H2	HY-383			
Renegade		68-76	2100	F2	FD-301	FD-301NS	FD-301PP	FD-301CP
ASTON MARTIN								
DB'S 3995	3995	69-70	CD175	CD1x3	CD-205	ZE-864NS	CD-201PP	
DB4, DB4S, DB5	3670	60-64	HD8	SU1x2	SU-764	SU-750NS		
DB4, DB5-GT	3670	61-65	45DCOE	W2x3	WE-805	WE-805NS*		
DB5, DB5 Vantage	3995	66-74	45DCOE	W2x3	WE-805	WE-805NS*		
DB6 399	3995	65-69	HD8	SU1x3	SU-764	SU-750NS		
DBS V8	5340	69-83	42DCNF	W2x4	WE-838	WE-805NS*	WE-802PP	
V8 Vantage	5340	77-83	48DF	W2x4	WE-834	WE-800NS		
AUDI								
100								
	1984	8/76-4/78	34/342B3	Z2	ZE-8607			
100/5 & Avant								
	1921	8/80-84	26/30DC	K2	KN-452A	KN-452NS		
	2144	4/78-8/79	34/34 2B2	Z2	ZE-8600			
	2144	9/78-6/82	34/34 2B2	Z2	ZE-8601			
100GL	1875	73-77	32/36DIDT	SL2	SX-726			
100LS	1760	70-73	32/35TDID	SL1	SX-7099	SX-710NS	SX-705PP	
80	1588	9/79-8/82	34/342B2	Z2	ZE-8600			
80								
	1477	8/72-8/75	32/35TDID,TA	SL2	SX-7099	SX-710NS	SX705PP	
	1588	8/75-8/79	35PDSIT-5	SL1	SX-7104			
	1588	8/75-8/79	35PDSIT-5	SL1	SX-7105			
	1471	8/72-9/74	35PDSIT-5	SL1	SX-712A			
	1588	5/74-8/74	35PDSIT-5	SL1	SX-731			
	1696	67-70	35PDSIT	SL1	SX-733			
	1781	9/79-7/83	36IB3	SL1	SX-745			
	1921	8/82 on	28/30 2E2	Z2	ZE-8602			
	1588	9/75-8/79	34/34 2B2	Z2	ZE-8607			
	1921	10/74-7/75	35PDSIT-5	SL1	SX-712A			
80/5	1921	8/80-7/81	34/34 2B5	Z2	ZE-8601			
90 Super	1760	67-70	32/36DIDT	SL2	SX-726			
Fox								
GL	1471	73-75	32/35TDID	SL1	SX-7099	SX-710NS	SX-705PP	
GLS	1588	9/75-2/79	34/34 2B2	Z2	ZE-8600			

Notes:

* WE-805NS is available in different sizes, refer to page 2









5 FD-304NS Primary N/Seat FD-305 Secondary N/Seat

Carburettor Repair Kits & Parts

 Make & Model	 Eng Size	 Year	 Carb. Model	Type of carb, No. of barrels No. of carbs	 Repair Kit	 Needle & Seat	 Pump Plunger	 Choke Pull Off
AUSTIN								
1100	1098	63-75	HS2, HS4	SU1	SU-750	SU-750NS		
1300	1298	68-75	HS4	SU1	SU-750	SU-750NS		
1300GT	1298	69-75	HS2	SU1x2	SU-750	SU-750NS		
1800	1798	64-74	HS6	SU1	SU-754	SU-750NS		
A110	2912	62-68	H4	SU1	SU-765	SU-750NS		
A40								
Farina	1098	61-67	HS2	SU1	SU-750	SU-750NS		
A60	1622	62-65	HS2	SU1	SU-750	SU-750NS		
Allegro								
1100	1098	74-80	HS4	SU1	SU-750	SU-750NS		
1300	1275	74-76	HS4	SU1	SU-750	SU-750NS		
1300	1275	76-80	HS4 Capstat	SU1	SU-768	SU-750NS		
1500	1485	74-76	HS6	SU1	SU-754	SU-750NS		
1500	1485	76-79	HS6 Capstat	SU1	SU-769	SU-750NS		
1500 TC	1485	79	HIF4	SU1x2	SU-759	SU-750NS		
Kimberley	2227	70-73	HS6	SU1x2	SU-754	SU-750NS		
Maxi								
1500,1750	1485,1750	69-78	HS6	SU1	SU-754	SU-750NS		
1750 HL	1786	72-74	HS6	SU1x2	SU-754	SU-750NS		
Hi-line	1786	75-78	HS6 Capstat	SU1x2	SU-769	SU-750NS		
850								
850	850	59-82	HS2	SU1	SU-750	SU-750NS		
Auto Mkl & MklI	850	65-74	HS4	SU1	SU-750	SU-750NS		
Clubman	1275	69-82	HS4	SU1	SU-750	SU-750NS		
Clubman	998-1098	65-74	HS4	SU1	SU-750	SU-750NS		
Clubman GT	1275	72-81	HS2	SU1x2	SU-750	SU-750NS		
Mini Cooper								
All Models	997-1275	64-71	HS2	SU1x2	SU-750	SU-750NS		
Montego Estate		85 on	HIF44	SU1	SU-756	SU-756NS		
Princess								
1800	1798	74-76	HS6	SU1	SU-754	SU-750NS		
1800	1798	76-79	HS6 Capstat	SU1	SU-769	SU-750NS		
2000,2200	2227	78-82	HIF6	SU1	SU-760	SU-750NS		
Tasman		70-73	HS6	SU1	SU-754	SU-750NS		
AUSTIN HEALEY								
100 6 Cylinder, BN4	2639	55-58	HD6	SU1x2	SU-763	SU-750NS		
3000 MKI	2912	57-58	HD6	SU1x2	SU-763	SU-750NS		
3000 MklI	2912	59-64	HS6	SU1x2	SU-754	SU-750NS		
Sprite								
MKI 'Bug Eye'	948	58-61	H1	SU1x2	SU-765	SU-750NS		
MKI 11A.III	998-1275	61-70	HS2	SU1x2	SU-750	SU-750NS		
B.M.W.								
1600,1602,1800,2000,2002	1573-1990	67-76	38/40PDSI	SL1	SX-714	SX-700NS		
2000								
Ti	1990	5/67-6/72	40PHH	SL2x2	SX-737			
2002 Auto	1990	74-76	DIDTA	SL2	SX-713	SX-710NS		

Notes:









Carburettor Repair Kits & Parts

 Make & Model	 Eng Size	 Year	 Carb. Model	Type of carb. No. of barrels No. of carbs	 Repair Kit	 Needle & Seat	 Pump Plunger	 Choke Pull Off
B.M.W. (Continued)								
2500								
Auto from 2190595	2494	69-75	32/35INAT	Z2X2	ZE-857A	SX-700NS	RT-604PP	
Auto to ch.2190594	2494	69-75	35/40INAT	Z2X2	ZE-855A	SX-700NS	RT-604PP	
Man.from 2180172	2494	69-75	32/35INAT	Z2X2	ZE-857A	SX-700NS	RT-604PP	
Man.to Ch.2180171	2494	69-75	35/40INAT	Z2X2	ZE-855A	SX-700NS	RT-604PP	
2800								
Auto from 2400218	2788	69-75	32/35INAT	Z2X2	ZE-857A	SX-700NS	RT-604PP	
Auto to Ch. 2400217	2788	69-75	35/40INAT	Z2X2	ZE-855A	SX-700NS	RT-604PP	
Man from 2331186	2788	69-75	32/35INAT	Z2X2	ZE-857A	SX-700NS	RT-604PP	
Man to Ch. 233185	2788	69-75	35/40INAT	Z2X2	ZE-855A	SX-700NS	RT-604PP	
3.3	3295	74-75	INAT	Z2X2	ZE-857A	SX-700NS	RT-604PP	
3.0LA 3.0S 3.0CS,3.3L	2986,3295	71-78	INAT	Z2X2	ZE-857A	SX-700NS	RT-604PP	
316,318	1573	5/76on	32/32DIDTA	SL4	SX-717			
320 4 Cyl.	1977	75-80	DIDTA	SL2	SX-713	SX-710NS		
320,520 6cyl	1990	59-72	4A1	SL4	SX-717			
520 4 Cyl.	1990	73-77	CD175	Z1X2	CD-202	CD-202NS	CD-201PP	
525,528	2494,2788	74-76	32/35INAT	Z2X2	ZE-857A	SX-700NS	RT-604PP	
628,630CS	2788,2986	59-72	4A1	SL4	SX-717			
728,730	2788-2985	77-79	4A1	SL4	SX-717			
BEDFORD								
A7 Series	2.6	61-67	42VN	Z1	ZE-851X	ZE-864NS		
E Series	308ci-5044	78 on	2GV	R2	RT-611A			
JO Series	3.3	61-67	42VN	Z1	ZE-851X	ZE-864NS		
Truck								
	214ci	59-72	37VNR	Z1	ZE-851X	ZE-864NS		
	300ci	70-76	BXUV3	S1	SB-658	SB-651NS		
(2 STUD MOUNT)	300ci	58-68	42VNR	Z1	ZE-851X	ZE-864NS		
(4 STUD MOUNT)	300ci	59-72	48VIR	Z1	ZE-864A	ZE-864NS		
	300ci	74	MV,IME	R2	RT-608			
Van								
CA	1508	45-56	30VIG	Z1	ZE-863	CD-200NS		
CA	1508	57-64	34VN	Z1	ZE-851 ⁽¹⁾	CD-200NS		
CA	1508	64-70	34IV	Z1	ZE-852	ZE-852NS		
CA	1508	65-70	30PSEI	Z1	ZE-853	ZE-853NS	ZE-853PP	
Van								
CF	1595-1975	71-76	36IV	Z1	ZE-852	ZE-852NS		
CF	2300	77 on	32ICT	W1	WE-801	WE-800NS	WE-802PP	
CF Holden eng.	173ci	73-78	BXU2	S1	SB-652	SB-650NS	SB-652PP	
CF Holden eng.	202ci-3298	78-79	BX	S1	SB-657	SB-650NS		
CHEVROLET								
Blazer	3800	85-	E2SE	R2	RT-610			
C20,C30,C50,C60,K20	6cyl, 292ci	75-78	1ME	R1	RT-608			
Belair & Impala	283 ci.	60-66	WCFB	C4	CA-163			
C20,C30 V8	350ci.	75-78	M4MC	R4	RT-609A	RT-602NS		RT-609CP
Camaro Z28	327-427ci.	81 on	M4MC	R4	RT-609A	RT-602NS		RT-609CP
Impala								
	327 ci.	65-67	2GC,GV	R2	RT-605	RT-604NS		
	327 ci.	65-67	4MV	R4	RT-613	RT-602NS	RT-602PP	

Notes:

1 Major Overhaul Kit available, refer to page 61









Carburettor Repair Kits & Parts

 Make & Model	 Eng Size	 Year	 Carb. Model	Type of carb. No. of barrels No. of carbs	 Repair Kit	 Needle & Seat	 Pump Plunger	 Choke Pull Off
CHRYSLER 4 Cylinder (See also Mitsubishi)								
Alpine	1442cc	77-80	36DCNV/A	W2	WE-827A	WE-805NS*	WE-800PP	
TC	1600cc	78-80	150CD-3	CD1x2	CD-200	CD-200NS	CD-200PP	
Avenger (Series 7)	1300/1600cc	78-80	150CD-3	CD1	CD-200	CD-200NS	CD-200PP	
Hunter	1724cc	78-79	150CD-3	CD1	CD-200	CD-200NS	CD-200PP	
Centura KB	1981	75-77	34ADSD	W2	WE-806	WE-800NS	WE-802PP	
CHRYSLER, VALIANT 6 Cylinder								
Centura KB	3523,4014	75-77	RBS	C1	CA-152	CA-152NS	CA-152PP	
KC	4014	77-78	BBD	C2	CA-154	CA-150NS	CA-154PP	CA-157CP
Chrysler CJ,CK	265ci	4/73-5/75	BBD	C2	CA-157	CA-150NS	CA-157PP	CA-157CP
CL,CM	215-265ci	11/75-81	BBD	C2	CA-154	CA-150NS	CA-154PP	CA-157CP
Valiant AP5	225ci	5/63-3/65	R2535	H1	HY-354			
AP5	225ci	5/63-3/65	R2807/8	H1	HY-373			
AP6,VC	145hp-225ci	3/65-10/67	BBS	C1	CA-156	CA-150NS	CA-157PP	CA-156CP
Pacer,VG	185hp-245ci	5/70-6/71	AVS4934S	C4	CA-159			
RT E37,E38,E49	265ci	6/71-4/73	45DCOE	W2X3	WE-805	WE-805NS*		
RV1,SV1	225ci	62-5/63	BBS	C1	CA-156	CA-150NS	CA-157PP	CA-156CP
VC,VE,VF	145hp-225ci	3/66-5/70	BXUV-3	S1	SB-653	SB-650NS	SB-653PP	
VE,VF	160hp-225ci	10/67-5/70	BBD/4300S	C2	CA-157	CA-150NS	CA-157PP	CA-157CP
VG	140hp-215ci	5/70-6/71	RBS	C1	CA-152	CA-152NS	CA-152PP	
VG	165hp-245ci	5/70-6/71	BBD4651S	C2	CA-157	CA-150NS	CA-157PP	CA-157CP
VH	215-245ci	6/71-4/73	RBS	C1	CA-152	CA-152NS	CA-152PP	
VH	203hp-265ci	6/71-4/73	BBD6482S	C2	CA-157	CA-150NS	CA-157PP	CA-157CP
VJ	215-245	73-75	RBS	C1	CA-152	CA-152NS	CA-152PP	
VJ	245-265	73-75	BBD	C2	CA-157	CA-150NS	CA-157PP	CA-157CP
VK	245-265	76-77	BBD	C2	CA-154	CA-150NS	CA-154PP	CA-157CP
CHRYSLER VALIANT 8 Cylinder								
Chrysler CK	360ci-5.9l	All	R7045A	H2	HY-360	HY-360NS	HY-360PP	HY-360CP
CL,CM	318ci-5.2l	11/76-81	BBD	C2	CA-154	CA-150NS	CA-154PP	CA-157CP
VG,VH,VJ	318ci-5.2l	70-74	BBD	C2	CA-157	CA-150NS	CA-157PP	CA-157CP
VH,VJ,VK	360ci-5.9l	71-75	R6517A	H2	HY-360	HY-360NS	HY-360PP	HY-360CP
Motorhome	383-400	71-75	R4668	H4	HY-391	HY-363NS	HY-350PP	
Imported	383ci	68-71	BBD 1-1/2"	C2	CA-153	CA-150NS		
Valiant AP6,VC,VE	273ci	3/65-3/69	BBD	C2	CA-157	CA-150NS	CA-157PP	CA-157CP
VF,VG,VH	273,318ci	3/69-4-73	BBD	C2	CA-157	CA-150NS	CA-157PP	CA-157CP
VH 4BBL	340ci-5.6l	72-73	AVS4934S	C4	CA-159			
VJ	318ci-5.2l	4/73-11/75	BBD	C2	CA-157	CA-150NS	CA-157PP	CA-157CP
VK	318ci-5.2l	11/75-11/76	BBD	C2	CA-154	CA-150NS	CA-154PP	CA-157CP

Notes:









* WE-805NS is available in different sizes, refer to page 2

Carburettor Repair Kits & Parts

 Make & Model	 Eng Size	 Year	 Carb. Model	Type of carb, No. of barrels No. of carbs	 Repair Kit	 Needle & Seat	 Pump Plunger	 Choke Pull Off
CITROEN								
CX Series	2175,2347	76-83	34DMTR	W2	WE-818	WE-800NS	WE-802PP	
D Spec & Deluxe	1985,2175	70-75	28/36DM	W2	WE-8082			
DS19,ID19	1911	65 on	28/36DDE	W2	WE-8082			
DS21,DS23,ID19,ID20	2175,2347	67-75	28/36DDE	W2	WE-8082			
G,GS1015/1220		72-78	28CIC	SL2	SX-7059			
COMMER								
2500 cwt	1725	73-78	34IV	Z1	ZE-852	ZE-852NS		
1600cc	1600	61-65	32PBIO	SL1	SX-736	SX-700NS		
1725cc	1725	65-73	34IV	Z1	ZE-852	ZE-852NS		
DAIHATSU								
Applause								
16V	1600	89-		A2	AN107NZ	AN-107NS	AN-107PP	
Charade								
CS, CSX	1000	87-		A2	AN107NZ	AN-107NS	AN-107PP	
G10 - Turbo	CB-993	80-84	32DIS	SL1	SX-7092			
G10,G11,G100	CB-993	80-92	87719/41	A2	AN-107NZ	AN-107NS	AN-107PP	
Turbo G11RT	CB-993	84-87	87716	A2	AN-129	AN-108NS	AN-100PP	
Max								
360	-356	71-77		HI1	HT-411			
Mira								
L201	-847	10/90 on		MS1	MS-514			
'CC' Van								
CB-993	CB-993	5/85-86		A2	AN-107NZ	AN-107NS	AN-107PP	
DAIHATSU COMMERCIAL								
550 Van								
S40	AB-547	76-77	87705	A1	AN-123			
Charade Duet Van	CB-993	4/83-5/85		A2	AN-107NZ	AN-107NS	AN-107PP	
Delta								
V107,108	4Y-2237	87 on		N2	NK-572A	NK-572NS		
V30,34,35	5R-1994	84 on	213324	N2	NK-563A	NK-563NS	NK-566PP	NK-563CP
V67,68	3Y-1998	11/84-10/88	73120	N2	NK-572A	NK-572NS		
Handi								
S60T,S60V 55 Wide	AB-547	77-81	87731/32	A1	AN-123			
S65T,S65V 55 Wide	AB-547	1/82-7/82		A1	AN-122			
Hi-line	FA-1490	60-72		A2	AN-107NZ	AN-107NS	AN-107PP	
L80V	-846			MS1	MS-514			
L80V	-846	85 on	32DIS	SL1	SX-7092			
Hi-jet Van								
S70V/76V 4WD	-843	7/82-84		A1	AN-122			
S70V/76V 4WD	CB-993	7/84-86		A2	AN-107NZ	AN-107NS	AN-107PP	
Rocky								
F80-87 4WD	3YC-1998	4/84-1/89		N2	NK-572A	NK-572NS		
Scat								
F10 4WD	FE-958	70-77		A2	AN-107NZ	AN-107NS	AN-107PP	
F20J-V,F25	12R-1587	78 on	31242	A2	AN-100A	AN-100NS	AN-100PP	
F20L	12R-1587	77-78		A2	AN-113A	AN-113NS	AN-100PP	

Notes:









Carburettor Repair Kits & Parts

 Make & Model	 Eng Size	 Year	 Carb. Model	Type of carb. No. of barrels No. of carbs	 Repair Kit	 Needle & Seat	 Pump Plunger	 Choke Pull Off
DAIMLER (Also See JAGUAR)								
Double Six V12 Limousine	5.3l	72-75	CD175	CD1X4	CD-205	ZE-864NS	CD-201PP	
	4.2l	70-72	HD8	SU1X2	SU-764	SU-750NS		
	4.2l	73-76	HS8	SU1X2	SU-770	SU-750NS		
	4.2l	77-83	HIF7	SU1X2	SU-771	SU-750NS		
Majestic-Major V8 Saloon V8 Sovereign	4.5L	64-68	HD8	SU1X2	SU-764	SU-750NS		
	2548	64-68	HD6	SU1X2	SU-763	SU-750NS		
	2.8,4.2l	68-71	HD8	SU1X2	SU-764	SU-750NS		
	2.8,4.2l	72-76	HS8	SU1X2	SU-770	SU-750NS		
	3.4,4.2L	77-78	HIF7	SU1X2	SU-771	SU-750NS		
SP 250 Sports	2498	59-61	HD6	SU1X2	SU-763	SU-750NS		
DATSUN (See Nissan)								
DODGE								
Custom Royal	361ci	58-69	BBD 1-1/2"	C2	CA-153	CA-150NS		
Phoenix	318ci	60-68	BBD 1-1/4"	C2	CA-154	CA-150NS	CA-157PP	CA-157CP
Plymouth Baracuda Truck 6 Cyl.	318ci		AFB	C4	CA-166			
		39-60	B&B	C1	CA-165	CA-150NS		
	225ci	60-69	BBS	C1	CA-156	CA-150NS	CA-157PP	
Truck Hemi 6 Cyl.	245ci	70 on	RBS	C1	CA-152	CA-152NS	CA-152PP	
	215ci	All	RBS	C1	CA-152	CA-152NS	CA-152PP	
	245ci	70-74	BBD	C2	CA-154	CA-150NS	CA-154PP	CA-157CP
	245ci	75-76	BBD	C2	CA-157	CA-150NS	CA-157PP	CA-157CP
Truck 8 Cyl.	383ci	67-71	BBD 1-1/2"	C2	CA-153	CA-150NS		
Truck 8 Cyl.								
	273,318ci	61-69	BBD	C2	CA-157	CA-150NS	CA-157PP	CA-157CP
	273,318ci	61-69	VW	S2	SB-660	SB-651NS		
	318ci	77 on	BBD 1-1/4"	C2	CA-154	CA-150NS	CA-154PP	CA-157CP
	361ci	All	2300	H2	HY-365	HY-350NS	HY-350PP	
FERRARI								
206, 246 Dino	2.0,2.4L	68-74	40DCNF	W2X3	WE-838	WE-805NS*	WE-802PP	
208	2000	75 on	34DCNF	W2X4	WE-838	WE-805NS*	WE-802PP	
275 GTS	3300	64-68	40DCN	W2x6	WE-845		HY-358PP	
308 Dino,GTB,GT4 Spider,GTS	2926	73	40DCNF	W2X4	WE-838	WE805NS*	WE-802PP	
365 GTB	4380	68-70	40DCN	W2X6	WE-845		HY-358PP	
365 GTC,400A,GT4	4380	72-76	38DCOE	W2X6	WE-805	WE-805NS*	WE-802PP	
FIAT								
124								
Coupe (twin cam)	1608	70-73	40P11x2	SL2X2	SX-7068			
Coupe (twin cam)	1438	68-71	34DHS	W2	WE-814	WE-800NS	WE-802PP	
Sedan	1186	67-71	32DHS	W2	WE-814	WE-800NS	WE-802PP	
Sedan	1592-1756	70-76	32,34DMS	W2	WE-825	WE-800NS		
Sedan	1608	70-73	40IDFx2	W2X2	WE-834A	WE-800NS		
Special	1438	68-73	32/34DHS	W2	WE-814	WE-800NS		

Notes:

* WE-805NS is available in different sizes, refer to page 2

Carburettor Repair Kits & Parts









 Make & Model	 Eng Size	 Year	 Carb. Model	Type of carb. No. of barrels No. of carbs	 Repair Kit	 Needle & Seat	 Pump Plunger	 Choke Pull Off
FIAT (Continued)								
125								
	1608	67-72	34DCHE	W2	WE-832A	WE-800NS		
Sedan	1608	67-72	34PAIA	SL2	SX-7071	SX-700NS		
126	594-652	73-83	28IMB	W1	WE-840			
127								
Sports	1049-1301	78-83	34DMTR	W2	WE-818	WE-800NS	WE-802PP	
128								
SL Coupe	1116-1290	72-78	32DMTR	W2	WE-818	WE-800NS	WE-802PP	
131								
	1297-1301	74-81	32ADF	W2	WE-810	WE-800NS		
Mirafiori	1585	76-78	32ADFA	W2	WE-810	WE-800NS		
Super Mirafiori	1585	79-81	32ADFA	W2	WE-810	WE-800NS		
Superbrava	1995	81-85	34ADFA	W2	WE-810	WE-800NS		
132								
Sedan	1756,1995	73-84	32ADFA	W2	WE-810	WE-800NS		
Sedan	1585-1756	72-75	34DMS	W2	WE-825	WE-800NS		
850								
Coupe, Spyder	903	66-73	30DIC	W2	WE-846	WE-800NS		
Argenta	1995	82-84	34ADF	W2	WE-810	WE-800NS		
Regata 85,100	1498,1585	85-87	32/34DMTRA	W2	WE-818	WE-800NS	WE-802PP	
Ritmo Abarth 130TC	1995	84-86	40DCOE	W2x2	WE-805	WE-805NS*		
X19								
	1290	73-78	32DMTR	W2	WE-818	WE-800NS	WE-802PP	
Coupe	1290,1499	78-83	32DATRA	W2	WE-832A	WE-800NS	WE-802PP	WE-832CP
FORD EUROPEAN 4 & 6 Cylinder								
Anglia, Consul, Prefect, Zephyr								
100E S.V	997	53-59	26ZIC	SL1	SX-744A			
105E O.H.V	997	59-62	30ZIC	SL1	SX-744A			
MK11 & 1500	1198-1498	58-65	33VN	Z1	ZE-851	CD-200NS		
113E	1200	62-67	30PSEI	SL1	ZE-853	ZE-853NS		
MKIV	2.5L	67-68	36IVT	Z1	ZE-852	ZE-852NS		
MKIV	2.0L	68-72	40DFAV	W2	WE-829			
Capri								
1300 X-Flow	1297	11/68-4/73	1250	F1	FD-300 (1)	FD-300NS	FD-300PP	
1300 GT X-Flow	1297	11/68-9/71	32DFE	W2	WE-802	WE-800NS	WE-802PP	
1600 X-Flow	1598	11/68-8/72	1250	F1	FD-300 (1)	FD-300NS	FD-300PP	
1600 GT X-Flow	1598	11/68-8/72	32DFM	W2	WE-802	WE-800NS	WE-802PP	
1600 Ohc	1598	9/72-4/73	32/36DGV	W2	WE-800 (1)	WE-800NS	WE-800PP	
1600 GT Ohc	1598	9/72-4/73	32/36DGV	W2	WE-800 (1)	WE-800NS	WE-800PP	
2000 GT V4 Eng.	1996	69-73	32/36DFV	W2	WE-812	WE-800NS		
2000 GT 4 cyl. Ohc	1993	78-83	32/36DGAV	W2	WE-800 (1)	WE-800NS	WE-800PP	WE-803CP
3000 GT	V6-2994	69-74	40DFAV	W2	WE-829			
3000 GT	V6-2994	75-83	38DGAS	W2	WE-824		WE-800PP	

Notes.

* WE-805NS is available in different sizes, refer to page 2

1 Major Overhaul Kit available, refer to page 61









Carburettor Repair Kits & Parts

 Make & Model	 Eng Size	 Year	 Carb. Model	Type of carb. No. of barrels No. of carbs	 Repair Kit	 Needle & Seat	 Pump Plunger	 Choke Pull Off
FORD EUROPEAN 4 & 6 Cylinder (Continued)								
Cortina								
MKI 113E	1200	10/62-8/67	30PSEI-2 & 3	SL3	ZE-853	ZE-853NS	ZE-853PP	
MKI 116E	1500	7/63-8/67	33VN-2	Z1	ZE-851	CD-200NS		
MKI 1500 GT 122E	1500	63-8/67	28/36DCD	W2	WE-804	WE-800NS		
MKII X-Flow	1300	8/67-8/70	1250	F1	FD-300 (1)	FD-300NS	FD-300PP	
MKII X-Flow	1600	9/67-8/70	1250	F1	FD-300 (1)	FD-300NS	FD-300PP	
MKII GTE X-Flow	1600	9/67-8/70	32DFM	W2	WE-802	WE-800NS	WE-802PP	
MKIII X-Flow	1300	8/70-4/73	1250	F1	FD-300 (1)	FD-300NS	FD-300PP	
MKIII X-Flow	1600	8/70-10/72	1250	F1	FD-300 (1)	FD-300NS	FD-300PP	
MKIII Ohc	1600	8/70-4/73	32/26DGV	W2	WE-800 (1)	WE-800NS	WE-800PP	
MKIII Ohc	2000	8/70-12/75	32/36DGAV	W2	WE-800 (1)	WE-800NS	WE-800PP	WE-803CP
MKIII Ohc	2000	1/76-5/77	32/36 DGAV-01	W2	WE-800 (1)	WE-800NS	WE-800PP	WE-800CP
MKIV Ohv	1600	5/77-80	1250	F1	FD-300 (1)	FD-300NS	FD-300PP	
MKIV Ohc	2000	5/77-80	32/36 DGAV-01	W2	WE-800 (1)	WE-800NS	WE-800PP	WE-800CP
MKV Ohc	1600	6/80-6/83	V.V.	F1	FD-307			
MKV Ohc	2000	6/80-6/83	32/26DGAV	W2	WE-800 (1)	WE-800NS	WE-800PP	WE-800CP
MKV V6	2300	80-86	34 DGAS	W2	WE-824		WE-800PP	
	2300	80-86	EEIT	SL2	SX-7086			
Escort								
1100,1300 MKI, II	1098,1297	68-81	1250	F1	FD-300 (1)	FD-300NS	FD-300PP	
1300 GT	1560	3/70-71	32DFE	W2	WE-802	WE-800NS	WE-802PP	
1600	1598	6/76-81	1250	F1	FD-300 (1)	FD-300NS	FD-300PP	
1600 GT Ohc		11/71-6/72	32/36DGV	W2	WE-800 (1)	WE-800NS	WE-800PP	WE-803CP
2000	1993	7/77-1/79	32/36DGAV	W2	WE-800 (1)	WE-800NS	WE-800PP	WE-803CP
2000	1993	2/79-81	32/36DGAV-0	W2	WE-800 (1)	WE-800NS	WE-800PP	
Sierra								
1600		5/84-8/85	V.V.	F1	FD-307			
2000		5/84-8/85	32/36DGAV	W2	WE-800 (1)	WE-800NS	WE-800PP	
1600		9/85-	28-32DFTH	W2	WE-8084	WE-800NS		WE-8084CP
2000		9/85-	30/34DFTH	W2	WE-8084	WE-800NS		WE-8084CP
1600-2000		84-85	34ICH	W1	WE-8083	WE-800NS	WE-802PP	
FORD JAPAN								
Festiva								
1.3	1323	90 on		A2	AN-127			
Laser								
1.1, 1.3 KA,KB	1071,1296	3/81-11/85	DCT306	H2	HT-401	HT-412NS	HT-401PP	
1.3, 1.5 KC,KE	1297,1490	12/85-1/90	DCT306	H2	HT-401	HT-412NS	HT-401PP	
Sports KA,KB	1296,1490	7/83-11/85	DCT306	H2X2	HT-401	HT-412NS	HT-401PP	
Hatch-GHIA	1324	2/90-		A2	AN-127			
Hatch-GHIA	1598	2/90-		A2	AN-127			
Telstar								
1.6	1587	7/83-92		N2	NK-575A			
2.0	1998	7/83-92		N2	NK-575A			
Orion	1998	91-		N2	NK-575A			









Notes:

1 Major Overhaul Kit available, refer to page 61

Carburettor Repair Kits & Parts

 Make & Model	 Eng Size	 Year	 Carb. Model	Type of carb. No. of barrels No. of carbs	 Repair Kit	 Needle & Seat	 Pump Plunger	 Choke Pull Off
FORD AUSTRALIA 6 Cylinder								
Cortina								
Ghia TC,TD	4089	72-76	BV2,BOV2	S1	SB-654	SB-650NS	SB-655PP	
Ghia TD,TE,TF	3273-4089	76-82	BX	S1	SB-655	SB-650NS	SB-655PP	
Fairlane								
ZA,ZB,ZC,ZD	200-221	67-72	BV2,BOV2	S1	SB-653	SB-650NS	SB-653PP	
ZD,ZF	250	71-73	WW	S2	SB-651	SB-651NS	SB-651PP	SB-651CP
ZG	250	12/74/75	BOV2	S1	SB-654	SB-650NS	SB-654PP	
ZJ,ZH	4.1	79-3/82	BX	S1	SB-655	SB-650NS	SB-655PP	
ZK,ZL	4.1	4/82 on	34ADM	W2	WE-844 (1)	WE-800NS	WE-844PP	WE-844CP
Falcon, Fairmont								
XA,XB	200-250	72-12/76	BOV2	S1	SB-654	SB-650NS	SB-655PP	
XC,XD	3.3-4.1	76-2/80	BX	S1	SB-655	SB-650NS	SB-655PP	
XE,XF	3.3-4.1	3/80 on	34ADM	W2	WE-844 (1)	WE-800NS	WE-844PP	WE-844CP
XK	144	60-62	1904	H1	HY-355			
XL,XM	144-170	62-64	1909	H1	HY-372			
XP	170	65-66	1100	F1	FD-303			
XR-XA	170-250	66-73	BV2,BOV2	S1	SB-653	SB-650NS	SB-653PP	
XY,XA	250 2V	71-73	WW	S2	SB-651	SB-651NS	SB-651PP	SB-651CP
FORD AUSTRALIA 8 Cylinder								
Early Ford V8								
	side valve		94	H2	HY-351			
	side valve		97	S2	SB-663			
Fairlane								
ZA,ZB	289,302	68-70	2100	F2	FD-301	FD-301NS	FD-301PP	FD-301CP
ZC,ZD,ZF	351ci.	71-74	4300	F4	FD-304	see note (2)	FD-304PP	
ZC,ZD,ZF	302ci.	70-73	WW	S2	SB-651	SB-651NS	SB-651PP	SB-651CP
ZC,ZD,ZF,ZG	351ci.	70-76	2100	F2	FD-301	FD-301NS	FD-301PP	FD-301CP
Falcon GTHO								
Phse I XW	Windsor	69	4150	H4	HY-357	HY-350NS	HY-350PP	
Phse II XY	Cleveland	70	4150	H4	HY-357	HY-350NS	HY-350PP	
Phse III XY,XA	Cleveland	71-72	4150	H4	HY-357	HY-350NS	HY-350PP	
Falcon Fairmont								
XB	302ci.	1/75-76	BBD	C2	CA-150 (3)	CA-150NS	CA-150PP	
XB	302ci.	73-12/74	BBD	C2	CA-157	CA-150NS	CA-157PP	CA-157CP
XC,XD,XE	4.9,5.8L	76-83	TQ	C4	CA-151	CA-151NS	CA-151PP	see note (4)
XR,T,W,Y,A	302,351ci.	67-76	4300	F4	FD-304	see note (2)	FD-304PP	
XR,XT	289,302ci.	66-69	2100	F2	FD-301	FD-301NS	FD-301PP	FD-301CP
XW,XY,XA	302ci.	70-73	WW	S2	SB-651	SB-651NS	SB-651PP	SB-651CP
XW,Y,A,B	351ci.	70-76	2100	F2	FD-301	FD-301NS	FD-301PP	FD-301CP
Ford Mustang								
	289-302ci.	78	2150	F2	FD-306A	FD-301NS		FD-301CP
	302-429ci.	69-73	4160	H4	HY-350	HY-350NS	HY-350PP	
	289-351ci.	65-73	2300	H2	HY-353	HY-350NS	HY-350PP	
	302 Boss	71	4150	H4	HY-357	HY-350NS	HY-350PP	
Lincoln Continental								
LTD	302-429ci.	76	2150	F2	FD-306A	FD-301NS		FD-301CP
Notes:								
1 Major Overhaul Kit available, refer to page 61				2 Primary Needle & Seat FD-304NS, Secondary Needle & Seat FD-305NS				
3 Water heated Plate CA-150EAK, refer to page 12				4 CA-151CP and CA-151CPA refer to page 6				

Carburettor Repair Kits & Parts









 Make & Model	 Eng Size	 Year	 Carb. Model	Type of carb. No. of barrels No. of carbs	 Repair Kit	 Needle & Seat	 Pump Plunger	 Choke Pull Off
FORD AUSTRALIA 8 Cylinder (Continued)								
Marquis ZG,ZH	302ci.	75-76	BBD	C2	CA-150 (3)	CA-150NS	CA-150PP	
Marquis ZH,ZJ,ZK	351ci.	76-84	TO	C4	CA-151	CA-151NS	CA-151PP	see note (4)
O.H.V.	V8	56-59	2300	H2	HY-352			
FORD COMMERCIAL 4 & 6 Cylinder								
Courier								
VC-1769		78-2/82	215282	N2	NK-550	NK-550NS	NK-550PP	
4WD FE	F2-2184	5/87 on		N2	NK-575A		MS-500PP	
4WD	4G54B-2555	87 on	DIDTA	MS2	MS-505ANZ	MS-505NS	MS-500PP	MS-505CP
Utility	1789-1998	9/85-8/88		N2	NK-575A			
Econovan								
80 Ser. Maxi Van	F2-2164	5/84-85		N2	NK-575A			
Maxi Van	1586,1789	6/79-4/84	220282	N2	NK-554			
Maxi Van	1789,1998	10/85-92	DGC306-	Hi2	HT-428			
Maxi Van	1415,1586	5/84-85		N2	NK-575A			
Escort								
Panel Van	1598	70-81	1250	F1	FD-300 (1)	FD-300NS	FD-300PP	
Spectron								
4WD	1789-2555	6/87 on	DIDTA	MS2	MS-505ANZ	MS-505NS	MS-500PP	MS-505CP
Mini Bus	1586-1789	2/83-10/85	220282	N2	NK-554			
Mini Bus	1586,1989	3/84-10/86		N2	NK-575A			
Trader								
	1985	6/79-81		N2	NK-555			
Transit Van								
V4	1663,1996	65-73	1250	F1	FD-300 (1)	FD-300NS	FD-300PP	
V4	1993	84 on	V V	F2	FD-307			
D Series 300								
			1100	F1	FD-303			
F100,250,350								
		71-74	YF	C1	CA-158			
		1/74-11/75	BOV-2	S1	SB-654	SB-650NS	SB-655PP	
		12/75-6/78	BOV-2	S1	SB-654	SB-650NS	SB-655PP	
		7/78-80	BX	S1	SB-657	SB-650NS		
		9/82 on	34 ADM	W2	WE-844 (1)	WE-800NS	WE-844PP	WE-844CP
D10 Some Models		75-77	1940,DOHF	H1/F1	HY-364		HY-360PP	
Auto		70	1100	F1	FD-303			
Manual		70	YF	C1	CA-158			
F100,350,500,600								
		65-74	2100	F2	FD-301	FD-301NS	FD-301PP	FD-301CP
		60-64	2300	H2	HY-353	HY-350NS	HY-350PP	
Transit Van								
125 (A/Post)	4089	73-75	BV-2	S1	SB-653	SB-650NS	SB-653PP	
125	4089	76-78	BOV-2	S1	SB-654	SB-650NS	SB-655PP	
175	3273,4089	78-81	BX	S1	SB-657	SB-650NS		
4 Cyl		84-87	V V	F1	FD-307			
6 Cyl		73-75	BV-2	S1	SB-653	SB-650NS	SB-653PP	
6 Cyl		76-78	BOV-2	S1	SB-654	SB-650NS	SB-655PP	
6 Cyl		78-80	BX	S1	SB-657	SB-650NS		

Notes:

1 Major Overhaul Kit available, refer to page 61
3 Water heated Plate CA-150EAK, refer to page 12

4 CA-151CP and CA-151CPA refer to page 6

Carburettor Repair Kits & Parts

 Make & Model	 Eng Size	 Year	 Carb. Model	Type of carb, No. of barrels No. of carbs	 Repair Kit	 Needle & Seat	 Pump Plunger	 Choke Pull Off
FORD COMMERCIAL 8 Cylinder								
F100,250,350								
	4089	74-78	BOV2	S1	SB-654	SB-650NS	SB-654PP	
	4089	82 on	34ADM	W2	WE-844 (1)	WE-800NS	WE-844PP	WE-844CP
Auto.	4089	71-74	YF	C1	CA-158			
incl 4WD	4089	75-77	1940 DOHF	H1	HY-364		HY-360PP	
incl 4WD	4089	78 on	BX	S1	SB-657	SB-650NS		
F100,350,500,600								
	302-351ci	77 on	TQ	C4	CA-151	CA-151NS	CA-151PP	see note (4)
	289-302ci	75-76	BBD	C2	CA-157	CA-150NS	CA-157PP	CA-157CP
	302ci	76-78	W W	S2	SB-651	SB-651NS	SB-651PP	SB-651CP
	302ci	75-78	BBD	C2	CA-150 (3)	CA-150NS	CA-150PP	
	302ci	75-78	4300	F2	FD-304	see note (2)	FD-304PP	
Late O.H.V. V8								
		59-69	4150	H4	HY-381	HY-350NS	HY-350PP	
Louisville								
LN700,900		All	R7419	H4	HY-381	HY-350NS	HY-350PP	
Maverick								
4WD	Y60-4169	2/88-92	211360	N2	NK-577			
Truck								
		65-69	2300G	H2	HY-365	HY-350NS	HY-350PP	
D Series 300	4916	All	1100	F1	FD-303			
D Series 300	4940	65-67	361V	Z1	ZE-852	ZE-852NS		
F500		70-72	2100	F2	FD-301	FD-301NS	FD-301PP	FD-301CP
F600-700		63-64	4150G	H4	HY-381	HY-350NS	HY-350PP	
F700		70-72	2300G	H2	HY-365	HY-350NS	HY-350PP	
F750		72	4150G	H4	HY-381	HY-350NS	HY-350PP	
XLT Bronco								
	4.9-5.8L	81 on	TQ	C4	CA-151	CA-151NS	CA-151PP	see note (4)
G.M. USA - BUICK - CHEVROLET - PONTIAC (See also Chevrolet)								
Buick								
	V6	83 on	E2ME,M2ME	R2	RT-622			
Chevrolet								
C20,C30	6cyl	All	1ME	R1	RT-608	RT-602NS		RT-609CP
Chevrolet								
C20,C30	V8-5735	79 on	M4ME	R4	RT-609A	RT-602NS		RT-609CP
Car & Truck								
	283-348	58-65	WCFB	C4	CA-163			
		32-46	W1	C1	CA-168			
		50-56	B, BC	R1	RT-600			
	283-327	58-69	2GC,GV	R2	RT-605	RT-605NS		RT-605CP
	327-427	67-70	4MV	R4	RT-606A	RT-602NS		RT-606CP
	230,250	68-70	1ME	R1	RT-608			
	305,350	58-69	2GV (large)	R2	RT-611A			RT-611CP
	283-348	56-66	4GC	R4	RT-612			
	327-427	65-67	4MV	R4	RT-613	RT-602NS	RT-602PP	
	305-550	76-	M4MV	R4	RT-609A	RT-602NS		RT-609CP

Notes:









1 Major Overhaul Kit available, refer to page 6

2 Primary Needle & Seat FD-304NS, Secondary Needle & Seat FD-305NS

3 Water heated Plate CA-150EAK, refer to page 12

4 CA-151CP and CA-151CPA refer to page 6









Carburettor Repair Kits & Parts

 Make & Model	 Eng Size	 Year	 Carb. Model	Type of carb. No. of barrels No. of carbs	 Repair Kit	 Needle & Seat	 Pump Plunger	 Choke Pull Off
HILLMAN - HUMBER								
Avenger								
	1300	70-77	150CD	CD1	CD-200	CD-200NS	CD-200PP	
	1800	76-78	HS6	SU1	SU-754	SU-750NS		
	1300	73-76	HS4C	SU1	SU-773	SU-750NS		
Alpine T.C	1800	76-78	150CD3	CD1x2	CD-200	CD-200NS	CD-200PP	
Hunter								
Arrow	1725	67-73	150CD	CD1	CD-200	CD-200NS	CD-200PP	
GT, Hust, Royal, Arrow	1725	67-73	150CD	CD1x2	CD-200	CD-200NS	CD-200PP	
GT, Hustler, Royal	660	68-73	150CD	CD1x2	CD-200	CD-200NS	CD-200PP	
Humber Sceptre		63-64	32 PAIA	SL2	SX-706			
Imp	875	64-69	30PIHT2,3	SL1	SX-709	ZE-853NS		
Minx								
I-III A, Husky I, II	1390	55-62	30VIG	Z1	ZE-863	CD-200NS		
III B, III C, V, VA	1494-1725	61-64	30VN	Z1	ZE-851	CD-200NS		
IV, Super Minx IV	1592	66-67	34IV	Z1	ZE-852	ZE-852NS		
V, VA Super Minx II	1592	62-65	33PSEI	Z1	ZE-853	ZE-853NS	ZE-853PP	
VI, Super Minx IV	1725	66-67	34IV	Z1	ZE-852	ZE-852NS		
Singer Gazelle	1725	63-66	32PAIA	SL2	SX-706			
Sunbeam								
Alpine	1725	63-66	32PAIA	SL2	SX-706			
Rapier	1725	63-66	32PAIA	SL2	SX-706			
Super-Snipe Ser.V	1725	65-68	175CD	CD1x2	CD-209	CD-200NS		
Vogue	1725	63-67	32PAIAS	SL2	SX-706	SX-700NS		
HOLDEN 4 Cylinder								
Apollo								
JK, JL	1SE-1998	8/89-12/90	74100/10	A2	AN-121	AN-121NS	AN-121PP	AN-121CP
Astra								
LB	E15-1488	84		Hi2	HT-420	HT-412NS	HT-420PP	
LB, LC	E15-1488	84-85	DCZ306	Hi2	HT-424	HT-412NS	HT-420PP	
LC	E16-1597	86-87		Hi2	HT-424	HT-412NS	HT-420PP	
Barina								
MB, ML	G13A-1324	85-89	82200	A2	AN-124NZ	AN-124NS	AN-107PP	
MF, MH	G13BA-1298	9/90 on		A2	AN-127			
Camira								
JB, JD	Famil-1598	82-86	Varajet	R2	RT-604A	RT-604NS	see note (6)	RT-604CP
Commodore								
VC, VH, VK	1892	80-87	Varajet	R2	RT-604A	RT-604NS	see note (6)	RT-604CP
Gemini								
RB	4CX1-1584	5/85 on	217260	N2	NK-573			
Sports (Optional)	1584	81-83	40IDF	W2x2	WE-834	WE-800NS		
TX, C, D, E, F, G	G161Z-1584	75-85	213304	N2	NK-563A	NK-563NS	NK-566PP	NK-563CP
Nova								
LE, LF	1397, 1587	9/89 on	16100/80	A2	AN-126	AN-121NS	AN-121PP	
Sunbird								
UC, LX	1897	76-77	32DIDTA	Z2	SX-700	SX-700NS	SX-700PP	SX-700CP
(Starfire) UC	1X-1892	78-80	Varajet	R2	RT-604A	RT-604NS	see note (6)	RT-604CP

Notes:

6 RT-604PP Bucket only, RT-604PPA complete assembly

Carburettor Repair Kits & Parts









 Make & Model	 Eng Size	 Year	 Carb. Model	Type of carb, No. of barrels No. of carbs	 Repair Kit	 Needle & Seat	 Pump Plunger	 Choke Pull Off
HOLDEN 4 Cylinder (Continued)								
Torana								
70 Series HB,LC	1159-1256	67-72	150CD	CD1	CD-200	CD-200NS	CD-200PP	
Brabham HB	1159-1256	67-69	150CD	CD1x2	CD-200	CD-200NS	CD-200PP	
HB,LC	1159	67-72	30PSEI-6	Z1	ZE-853	ZE-853NS	ZE-853PP	
Torana								
LC,LJ,TA	1599,1760	71-75	36IV	Z1	ZE-852	ZE-852NS		
LH,LX	1897	74-76	32DIDTA	SL2	SX-700	SX-700NS	SX-700PP	SX-700CP
LJ,TA	1256	72-75	30IZ	Z1	ZE-853	ZE-853NS	ZE-853PP	
HOLDEN 6 Cylinder								
Commodore								
VB	2.8,3.3L	78-79	BX	S1	SB-655	SB-650NS	SB-655PP	
VC,VH	1X-1892	80-83	Varajet	R2	RT-604A	RT-604NS	see note (6)	RT-604CP
VC,VH,VK	2.8,3.3L	80-3/86	Varajet	R2	RT-604A	RT-604NS	see note (6)	RT-604CP
Holden								
FJ-HJ	all	49-76	BXV,BXOV	S1	SB-652	SB-650NS	SB-652PP	
FX	2262	48-49	BXOV	S1	SB-664			
HD-X2,HR-X2	2930	65-67	BXUV	S1x2	SB-652	SB-650NS	SB-652PP	
HR,HK,HT	179-186	67-71	WW	S2	SB-651	SB-651NS	SB-651PP	SB-651CP
HX,HZ	2.8,3.3L	76-79	BX	S1	SB-655	SB-650NS	SB-655PP	
WB	3.3L-3298	80-84	Varajet	R2	RT-604A	RT-604NS	see note (6)	RT-604CP
Torana								
GTR XU-1	186	70-71	150CD-S	CD1x3	CD-200	CD-200NS	CD-200PP	
GTR XU-1	202-3298	72-73	175CD-2S	CD1x3	CD-201	CD-201NS	CD-201PP	
LC,LJ,LJ-GTR,LH	179-186	69-75	BXUV2&3	S1	SB-652	SB-650NS	SB-652PP	
LC-GTR	161,173	69-72	WW	S2	SB-651	SB-651NS	SB-651PP	SB-651CP
LH,LX	2.8,3.3L	75-76	BXUV3	S1	SB-652	SB-650NS	SB-652PP	
LX,UC	2.8,3.3L	76-79	BX	S1	SB-655	SB-650NS	SB-655PP	
HOLDEN 8 Cylinder								
Commodore								
VB	308-5044	78-79	4MV	R4	RT-602	RT-602NS	RT-602PP	RT-602CP
VB	253-4142	78-79	WW	S2	SB-651	SB-651NS	SB-651PP	SB-651CP
VC,VH,VK,VL	253,308	80 on	M4M	R4	RT-603	RT-602NS	RT-602PP	see note (7)
Holden								
HJ	253-4142	10/74-6/76	BBD	C2	CA-150	CA-150NS	CA-150PP	
HK,HT	307-5030	68-69	2GC	R2	RT-605	RT-605NS		RT-605CP
HT,HG,HQ,HJ	308-5044	69-75	4MV	R4	RT-601	RT-601NS	RT-601PP	RT-601CP
HT,HG,HQ,HX,HZ	253-4142	69-79	WW	S2	SB-651	SB-651NS	SB-651PP	SB-651CP
HX,HZ	308-5044	76-79	4MV	R4	RT-602	RT-602NS	RT-602PP	RT-602CP
Caprice HK/T/Q/G	327,350	69 on	4MV	R4	RT-606A	RT-602NS	RT-602PP	RT-606CP
Caprice, WB	4192,5044	80-85	M4M	R4	RT-603	RT-602NS	RT-602PP	see note (7)
Torana								
LH,LX	253-4142	74-78	WW	S2	SB-651	SB-651NS	SB-651PP	SB-651CP
SLR5000,L34	308-5044	74-76	4MW	R4	RT-601	RT-601NS	RT-601PP	RT-601CP
SLR5000,L34	308-5044	76-78	4MV	R4	RT-602	RT-602NS	RT-602PP	RT-602CP

Notes:

6 RT-604PP Bucket only, RT-604PPA complete assembly











7 RT-603CP and RT-603CPA refer to page 6

Carburettor Repair Kits & Parts

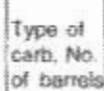
				Type of carb. No. of barrels No. of carbs				
Make & Model	Eng Size	Year	Carb. Model		Repair Kit	Needle & Seat	Pump Plunger	Choke Pull Off
HOLDEN, ISUZU COMMERCIAL & 4WD								
Drover								
QB	G13A-1324	85-87	83110	A2	AN-124NZ	AN-124NS	AN-107PP	
Isuzu								
Elf TGL52	G161Z-1584	76-78		N2	NK-563A	NK-563NS	NK-556PP	NK-563CP
HOLDEN, ISUZU COMMERCIAL & 4WD								
Jackaroo								
UB	G200Z-1949	11/81-11/82	213304	N2	NK-563A	NK-563NS	NK-556PP	NK-563CP
UB	4ZD1-2254	8/85-88		N2	NK-568A			
Rodeo								
KB-Series	1584-1949	79-7/85	213304	N2	NK-563A	NK-563NS	NK-556PP	NK-563CP
KB-Series	1949-2254	85-87		N2	NK-569A			
4ZD1	2300	87-		N2	NK-568A			
Scurry								
NB	F10A-970	7/85-87	30PHD	MS1	MS-506		MS-500PP	
Shuttle Van								
WFR	1817,1994	3/82-91	213304	N2	NK-568A			
Trooper								
4ZA1, 4ZD1	2300	87-		N2	NK-568A			
HONDA								
Accord								
	1488,1597	76 on	CA6,8,12-16	K3	KN-456			
	1598cc	77-79		K2	KN-450	KN-450NS	KN-450PP	
	1602cc	79-84		K2	KN-450	KN-450NS	KN-450PP	
12 Valve	1598cc	84-86		K2	KN-452A	KN-452NS		
12 Valve	1629cc	84-86	DE43BB	K2	KN-452A	KN-452NS		
12 Valve	1955cc	86 on	ED18	K2	KN-452A	KN-452NS		
12 Valve	1955cc	88 on		K2	KN-452A	KN-452NS		
EX	ET-1829	1/86-3/87		K2x2	KN-454			
EX	A20A2-1970	10/86 on		K2	KN-457	KN-450NS	KN-450PP	
Accord	1488,1597	76 on	CA6,8,12-16	K3	KN-456			
City								
FA	1231	10/82-10/86		K2	KN-450	KN-450NS	KN-450PP	
F.C.	1231	11/86	DA62/8,77	K2	KN-452A	KN-452NS		
Civic								
1200 EB1	1189cc	73-76	DCG306	H12	HT-412	HT-412NS	HT-412PP	
EB2	1237cc	77-80	DA76B	K2	KN-450	KN-450NS	KN-450PP	
1300	1335cc	80-83	DA76B	K2	KN-450	KN-450NS	KN-450PP	
1300 12 Valve	1342cc	84 on	DE30C	K2	KN-452A	KN-452NS		
1500 12 Valve	1488cc	84 on	DE30G	K2	KN-452A	KN-452NS		
1500 4 door	EC-1488	77-78	DA76B	K2	KN-450	KN-450NS	KN-450PP	
1500 16 Valve	1493	11/87-10/91		K2x2	KN-454			
C.V.C.C.	1488	75 on	CA23,CA020	K3	KN-455			
LX 16V	1493	88-		K2x2	KN-454			
LX 16V	1343	89-		K2x2	KN-454			
Concerto								
16V	1590	89-		K2x2	KN-454			



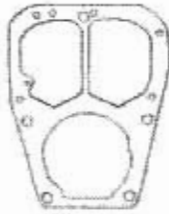
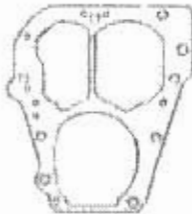
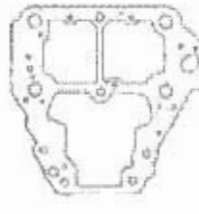





Notes:

Carburettor Repair Kits & Parts

 Make & Model	 Eng Size	 Year	 Carb. Model	 Type of carb. No. of barrels No. of carbs	 Repair Kit	 Needle & Seat	 Pump Plunger	 Choke Pull Off			
HONDA (Continued)											
Prelude	1602	79-81	DA76B	K2	KN-450	KN-450NS	KN-450PP				
	EL-1602	1/82	DA11DEO3	K2	KN-452A	KN-452NS					
12 Valve Shuttle	A20A2-1970	86		K2	KN-457	KN-450NS	KN-450PP				
	1829	83-6/86	VF53AC	K1x2	KN-454						
Shuttle	1488	84	DE30G	K2	KN-452A	KN-452NS					
HYUNDAI											
Excel	1298,1468	89 on	DIDTA	MS2	MS-500B	MS-500NS	MS-500PP	MS-500CP			
	1298-1468	86 on		N2	NK-585						
1500 Pony	4G12-1468	85 on	DIDTA	MS2	MS-505ANZ	MS-505NS	MS-500PP	MS-505CP			
One	1238-1439	82 on	DIDTA	MS2	MS-515						
	1238-1438	82	DIDTA	MS2	MS-515						
Two	1238-1439	82-86	DIDTA	MS2	MS-515						
Stella											
Prima	1997	86 on		N2	NK-585						
HYUNDAI KIT IDENTIFICATION											
											
MS-505ANZ			MS-515			MS-515			NK-585		
INTERNATIONAL											
Acco											
AA,AB		to 62	2110	H2	HY-351						
AB,C	5654	62-72	2300G	H2	HY-365	HY-350NS	HY-350PP				
C	6391	66-72	3787	H4	HY-381	HY-350NS	HY-350PP				
D	304,345	72-80	2300G	H2	HY-365	HY-350NS	HY-350PP				
Tilt Cab A,B,C		73-81	2300G	H2	HY-365	HY-350NS	HY-350PP				
Accol AB,ABT,ADM		62 on	BXUV3	S1	SB-658	SB-651NS					
Tilt Cab A,B,C,D	5654 6391	72 on	41509	H4	HY-381	HY-350NS	HY-350PP				
C1800-C1802		67-75	BXUV3	S1	SB-658	SB-651NS					
Aust. Army		66-75	BXUV3	S1x2	SB-659	SB-651NS					
Scout											
	5654	75 on	2210/45	H2	HY-360	HY-360NS	HY-360PP	HY-360CP			
Traveller	152cl	60-74	RS352A/3473A	H1	HY-355						
JAGUAR											
E' Type											
6 Cyl.	4.2l	69-70	CD175	CD1x2	CD-201	CD-201NS	CD-201PP				
6 Cyl.	3.8,4.2l	61-68	HD8	SU1x3	SU-764	SU-750NS					
V-12	5.3l	71-75	CD175	CD1x4	CD-205	ZE-864NS	CD-201PP				









Notes:

Carburettor Repair Kits & Parts

				Type of carb. No. of barrels No. of carbs				
Make & Model	Eng Size	Year	Carb. Model		Repair Kit	Needle & Seat	Pump Plunger	Choke Pull Off
JAGUAR (Continued)								
240		67-69	HS6	SU1x2	SU-754	SU-750NS		
3.4 'S'		67-68	HD6	SU1x2	SU-763	SU-750NS		
3.8 'S'		64-68	HD6	SU1x2	SU-763	SU-750NS		
340		67-68	HD6	SU1x2	SU-763	SU-750NS		
420, 420G		67-68	HD8	SU1x2	SU-764	SU-750NS		
MK II, III	3.8l	63-64	HD6	SU1x2	SU-763	SU-750NS		
	3.4l	60-64	HD6	SU1x2	SU-763	SU-750NS		
MKX	3.8, 4.2l	61-64	HD8	SU1x3	SU-764	SU-750NS		
XJ-12	5.3l	72-81	175CDSE	CD1x4	CD-205	ZE-864NS	CD-201PP	
V12	5.3l	72-81	175CD	CD1x4	CD-205	ZE-864NS	CD-201PP	
XJ-6	4.2l	70-71	175CD	CD1x2	CD-201	CD-201NS	CD-201PP	
	4.2l	75-78	175CDSE	CD1x2	CD-205	ZE-864NS	CD-201PP	
	2.8l	68-71	HD8	SU1x2	SU-764	SU-750NS		
	4.2l	68-71	HD8	SU1x2	SU-764	SU-750NS		
	2.8l	71-73	HS8	SU1x2	SU-770	SU-750NS		
	4.2l	72-75	HS8	SU1x2	SU-770	SU-750NS		
	3.4l	75-76	HS8	SU1x2	SU-770	SU-750NS		
	4.2l	75-78	HIF7	SU1x2	SU-771	SU-750NS		
	3.4l	76-83	HIF7	SU1x2	SU-771	SU-750NS		
JEEP - See AMC Jeep								
JENSEN								
Healey	1973	Some	175CD	CD1x2	CD-201	CD-201NS	CD-201PP	
GT	1973	7/75-76	40DHLAE	D2x2	DE-250	DE-250NS	DE-250PP	
Sports	1973	3/72-74	45 DHLA	D2x2	DE-250	DE-250NS	DE-250PP	
Interceptor								
MKIII	383,440	10/71-72	4160	H4	HY-391	HY-363NS	HY-350PP	
MKIII FF	383,440	71	AVS	C4	CA-159			
SP	440	5/72-73	2300	H2x3	HY-390			
LADA								
1300/1600 Sed		78-84	020N2	SL1	XA-0104			
Niva 4WD & Cabriolet	1570	7/83-92	32DCR	SL1	XA-0104			
Samar	1288	7/88-5/91	28/32Z10	SL2	XA-0105			
Taiga	1600	91 on		SL2	XA-0105			
LANCIA								
Beta								
Coupe HPE	1995	77-85	34DATA	W2	WE-822	WE-800NS	WE-800PP	WE-822CP
Sedan, Coupe 1800	1785	74-5/76	34DMTR	W2	WE-818	WE-800NS	WE-800PP	
Sedan, Coupe 2000	1995	6/76-84	34DATRA	W2	WE-832A	WE-800NS	WE-800PP	WE-822CP
Scorpion		76-78	34DATRA	W2	WE-832A	WE-800NS	WE-800PP	WE-822CP

Notes:









Carburettor Repair Kits & Parts

 Make & Model	 Eng Size	 Year	 Carb. Model	Type of carb. No. of barrels No. of carbs	 Repair Kit	 Needle & Seat	 Pump Plunger	 Choke Pull Off
LEYLAND AUSTRALIA AND U.K.								
1500								
TC - Series	1498	69-72	HS6 AUD288	SU1	SU-754	SU-750NS		
	1498	68-4/72	HS6 AUD385	SU1x2	SU-754	SU-750NS		
1800								
TC - Series	1798	67-11/70	HS6 AUD381	SU1	SU-754	SU-750NS		
	1798	86-11/70	HS6 AUD385	SU1x2	SU-754	SU-750NS		
Austin								
Freeway		62-66	34VN	Z1	ZE-851	CD-200NS		
Kimberley	2200	11/70-8/73	HS6	SU1x2	SU-754	SU-750NS		
Kimberley	2227	11/70-8/73	HS6 AUD409	SU1x2	SU-754	SU-750NS		
Leyland								
Mini Clubman	1098	75 on	HS4	SU1	SU-750	SU-750NS		
Mini Cooper'S'	1275	75 on	HS2	SU1x2	SU-750	SU-750NS		
Marina								
1500	1498	4/72-10/74	HS4 AUD 487	SU1	SU-750	SU-750NS		
1750 & 1.7L	1786	4/72-10/74	HS6	SU1	SU-754	SU-750NS		
1750 TC	1786	4/72-10/74	HS6 AUD504	SU1x2	SU-754	SU-750NS		
6 Cyl 2620cc	2620	11/73-11/74	HS6 AUD588	SU1	SU-754	SU-750NS		
Mini								
	848, 1098	76-82	HS2 FZX1239	SU1	SU-750	SU-750NS		
Sedan, Van & Moke	848, 1098	64-75	HS2 AUD668	SU1	SU-750	SU-750NS		
Morris								
Major/Elite	1498-1822	59-62	34VN	Z1	ZE-851	CD-200NS		
Mini	850, 1098	60 on	HS2, HS4	SU1	SU-750	SU-750NS		
Mini Moke	1100, 1300	64 on	HS2, HS4	SU1	SU-750	SU-750NS		
Minor Ser. I, II	998	To 59	H1, H2	SU1	SU-765	SU-750NS		
P-76								
6 Cyl.	2620	6/73-75	HS6 AUD588	SU1	SU-754	SU-750NS		
8 Cyl.	4416	6/73-75	WW	S2	SB-651	SB-651NS	SB-651PP	SB-651CP
Princess								
1800 (18/22)	1800	77-78	HS6	SU1	SU-769	SU-750NS		
Sherpa								
250 Van	1800	81-84	HIF44	SU1	SU-756	SU-756NS		
250 Van	1800	79-82	HIF6	SU1	SU-760	SU-750NS		
Tasman								
	2200	11/70-8/73	HS6 AUD419	SU1	SU-754	SU-750NS		
LOTUS								
Elan	1558	70-75	GD175	CD1x2	CD-201	CD-201NS	CD-201PP	
plus 2S-130.135		72-75	40DHLA	D2x2	DE-250	DE-250NS	DE-250PP	
Sprint plus 2S		71-72	40DCOE	W2x2	WE-805	WE-805NS*		
Elite								
Series II	1216	61-65	HS6	SU1x2	SU-754	SU-750NS		
Esprit								
503, 504	2174, 3.0L	74-83	45DHLA	D2x2	DE-250	DE-250NS	DE-250PP	
Turbo		80-83	40DHLA	D2x2	DE-250	DE-250NS	DE-250PP	
Europa								
Special	1558	73-75	40DOCE	W2x2	WE-805	WE-805NS*		
Twin Cam	1558	72-75	40DHLA	D2x2	DE-250	DE-250NS	DE-250PP	

Notes:

* WE-805NS is available in different sizes, refer to page 2









Carburettor Repair Kits & Parts

				Type of carb. No. of barrels No. of carbs				
Make & Model	Eng Size	Year	Carb. Model		Repair Kit	Needle & Seat	Pump Plunger	Choke Pull Off
LOTUS (Continued)								
Excel Coupe								
SE2+2	2174	4/89-91	45DH4A	D2x2	DE-250	DE-250NS	DE-250PP	
Lotus Cortina								
MK1, MKII	1558	63-67	40DOCE	W2x2	WE-805	WE-805NS*		
Super Seven Roadster								
	1598	66-69	40DOCE	W2x2	WE-805	WE-805NS*		
M.G.								
1100, 1300	1098, 1275	62-71	HS2, HS4	SU1x2	SU-750	SU-750NS		
A Twin Cam	1622	58	H6	SU1x2	SU-767	SU-750NS		
B.B-GT								
	1798	62-72	HS4	SU1x2	SU-750	SU-750NS		
	1798	72-82	HIF4	SU1x2	SU-759	SU-750NS		
V8	3528	73-76	HIF6	SU1x2	SU-760	SU-750NS		
Midget								
1500	1466	74-78	HS4	SU1x2	SU-750	SU-750NS		
MKII, III	1098, 1275	62-74	HS2	SU1x2	SU-750	SU-750NS		
TC, TD, TF,	1275, 1489	45-65	H2, H4	SU1x2	SU-765	SU-750NS		
Montego								
SL	1994	86 on	HIF44	SU1	SU-756	SU-756NS		
MAZDA PASSENGER								
808, 1000, 1200	987, 1169	67-70	DCG306	Hi2	HT-412	HT-412NS	HT-412PP	
121								
FWD	B3-1323	3/87-2/91	BH0513	A2	AN-127			
121L RWD	1769, 1970	76-87	21582	N2	NK-550	NK-550NS	NK-550PP	
1500	1490	66-71	215282	N2	NK-550	NK-550NS	NK-550PP	
1800 SVA	1762	69-73		Hi1	HT-419			
323								
1300, 1500 RWD	1292-1490	77-80	DCG306	Hi2	HT-412	HT-412NS	HT-412PP	
1300, 1500 FWD	1296-1490	80-86	DCG-306	Hi2	HT-401	HT-412NS	HT-401PP	
FWD LX-GLX	1272-1598	87-90	BHO-513	A2	AN-127			
Sports FWD	E5-1490	81-5/85	DCT306	Hi2x2	HT-401	HT-412NS	HT-401PP	
GT	1598	81-85	DCT-306	Hi2x2	HT-401	HT-412NS	HT-401PP	
Astina GLX	1598	90 on		A2	AN-127			
626								
1600	1597	73-75	215282	N2	NK-550	NK-550NS	NK-550PP	
1800, 2000 FWD	1789-1998	83 on		N2	NK-575A			
2000 RWD	MA-1970	77-82	215282	N2	NK-550	NK-550NS	NK-550PP	
Fully Imported	MA-1970		210234	Hi2	HT-427			
FWD	FE-1998	10/87-10/89		N2	NK-572A			
FWD GLX	FE-1998	3/83-10/87		N2	NK-575A			
RWD	MA-1970	78-2/83	215282	N2	NK-550	NK-550NS	NK-550PP	
800								
	987	64-67	DCF 240	Hi2	HT-403			
929								
1800, 2000	1769, 1970	74-82	215282	N2	NK-550	NK-550NS	NK-550PP	
from Chas. HBES8E	FE-1998	1/84 on	21G304	N2	NK-575A			

Notes:









* WE-805NS is available in different sizes, refer to page 2

Carburettor Repair Kits & Parts

				Type of carb, No. of barrels No. of carbs				
Make & Model	Eng Size	Year	Carb. Model		Repair Kit	Needle & Seat	Pump Plunger	Choke Pull Off
MAZDA PASSENGER (Continued)								
Capella								
1600	NA-1586	70-78	215282	N2	NK-550	NK-550NS	NK-550PP	
1800	VC-1796	69-73		Hi2	HT-419			
RX2 Tr Chas -A8528	12A-1098	70-75		N4	NK-564			
RX2 Tr Chas -A8527	12A-1098	70-76		N4	NK-571			
Familia								
Import	1498	84-88		Hi2	HT-431			
Import	1597	84-88		Hi2	HT-431			
Mazda								
RX3	10A-982	71-9/73	KCD-306	Hi4	HT-418			
RX3,RX4	12A-1098	to 9/73 on		N4	NK-564			
RX4,RX5	13B-1298	10/73-78		Hi4	HT-415			
RX7	12A-1098	79 on	210284	N4	NK-567			
R100								
10A Pre Emission		69-71	KCD-306	Hi4	HT-418			
RX2								
12A Capella		70-76		N4	NK-564			
12A Capella		70-76		N4	NK-571			
MAZDA COMMERCIAL								
323								
Wagon	1500 FWD	84-86	DCT306	Hi2	HT-401	HT-412NS	HT-401PP	
Wagon, RWD	1300,1500	78-83	DCG306	Hi2	HT-412	HT-412NS	HT-412PP	
Bongo								
F1000	PC-975	4/72 on	210028	N2	NK-553			
F800	SA-782	to 3/72	21002	N2	NK-552	NK-550NS		
Traveller, Mini Bus	1586-1998	3/83-1/88	220282	N2	NK-551			AN-102PP
Truck								
E2000	VB-1985	All		N2	NK-555			
E2000	VA-1985	70 on		N1	NK-557			
T2000,T2500	VA-1985	81 on		N2	NK-555			
T2600	G54B-2555	3/84 on	DITA	MS2	MS-505ANZ	MS-505NS	MS-500PP	
Utility								
1000	PB-987	70 on	DCG306	Hi2	HT-412	HT-412NS	HT-412PP	
B1500,B1600	1484,1586	64-1/85	215282	N2	NK-550	NK-550NS	NK-550PP	
B1800,B2000	1769,1970	71-82	215282	N2	NK-550	NK-550NS	NK-550PP	
B2000	MA-1970	6/83-85	215282D3	N2	NK-576			
B2000,B2200	1988,2184	6/85-11/91	21G304	N2	NK-575A			
B2600 4WD	G54B-2555	3/87-90	DiDTA	MS2	MS-500B	MS-500NS	MS-500PP	
Van								
E1300,E1400	1272,1415	78-83	DCG306	Hi2	HT-412	HT-412NS	HT-412PP	
E1400	1415,1490	80-6/86	DCG306	Hi2	HT-428	HT-412NS	HT-412PP	
E1400,E1600	1490,1586	78-7/86	220282	N2	NK-554	NK-554NS		
E1800,E2000	1789,1998	2/84-90	21G304	N2	NK-575A			
E2200	F2-2184	3/85	21G204-34	N2	NK-575A			









Notes:

Carburettor Repair Kits & Parts

 Make & Model	 Eng Size	 Year	 Carb. Model	Type of carb, No of barrels No. of carbs	 Repair Kit	 Needle & Seat	 Pump Plunger	 Choke Pull Off	
MERCEDES BENZ									
170S,SB,180A,180B,BC	1897	50-62	32PICB	SL1	SX-736	SX-700NS			
190	1897	9/83 on	175CDT	CD1	CD-203		CD-201PP		
190B	1897	56-59	32PAITA	SL2	SX-716	SX-700NS			
190C	1897	61-66	34PICB	SL1	SX-736	SX-700NS			
190SL	1897	55-63	44PHH	SL2x2	SX-737				
200	1988	65-68	36/40PDSI	SL2x2	SX-715	SX700NS	SX-712PP		
200 W123	1988	1/76 on	175CDT/CDTU	CD1	CD-203		CD-201PP		
200 W201	1988	8/82 on	175CDT	CD1	CD-203		CD-201PP		
200/8 W115		68-7/76	175CDS-CDT	CD1	CD-203		CD-201PP		
220B	2196	59-9/65	320ICB	SL1x2	SX-736	SX-700NS			
220S,220SB	2195,2196	56-9/63	32/34PAITA	SL2x2	SX-716	SX-700NS			
220SB	2196	9/63-6/65	35/40INAT	Z2x2	ZE-854A	SX-700NS	RT-604PP		
230	2306	9/65-1-67	36/40PDSI	SL1x2	SX-715	SX-700NS	RT-604PP		
230/4,230C,230T	2307	1/73-9/80	175CDTU	CD1	CD-203		CD-201PP		
230/6 W115	2292	7/73-7/76	175CDT	CD1	CD-203		CD-201PP		
230S,230/8 W114	2306	8/65-10/76	35/40INAT	Z2x2	ZE-854A	SX-700NS	RT-604PP		
250,250T W123,129	2778	1/76 on	4A1-32/54	SL4	SX-717				
250/8,250/8C W114	2778	1/68-12/76	35-40INAT	Z2x2	ZE-854A	SX-700NS	RT-604PP		
250S W114	2496	6/65-12/67	35/40INAT	Z2x2	ZE-854A	SX-700NS	RT-604PP		
280,280C,280S W116-126	2746	5/72 on	4A1-32/54	SL4	SX-717				
280S,280SE	2746	1/68 on	35/40INAT	Z2x2	ZE-854A	SX-700NS	RT-604PP		
300		51-54	40PBIC	SL1x2	SX-739				
MITSUBISHI PASSENGER									
Celeste									
ANC	4G35-1597	76-78	DID	MS2	MS-502	MS-500NS	MS-500PP		
LN-LP-LO	4G35-1597	78-80	DID	MS2	MS-502	MS-500NS	MS-500PP		
LN-LP-LO	4G-1995	78-80	DID	MS2	MS-502	MS-500NS	MS-500PP		
Chariot									
DX	4G37-1755	85-91	C26	A2	AN-124NZ	AN-124NS	AN-107PP		
	4G63-1997	91-	DIDTF	MS2	MS-511	MS-511NS	MS-500PP		
Colt									
RA	G12B-1410	87-88	DIDTA	MS2	MS-500B	MS-500NS	MS-500PP	MS-500CP	
Cordia									
CT-CV Turbo	4G32T-1597	83-84	DIDTA	MS2	MS-505ANZ	MS-505NS	MS-500PP		
CT-CV-CX-CZ	4G32-1597	83-87	C26	A2	AN-124NZ	AN-124NS	AN-107PP		
CX-CZ	4G62-1755	83-87	C26	A2	AN-124NZ	AN-124NS	AN-107PP		
Galant									
GTOA55	4G35-1686	72	DID	MS2x2	MS-502	MS-500NS	MS-500PP		
GTOA57	4G52-1995	73-75	DID	MS2x2	MS-502	MS-500NS	MS-500PP		
NA/YB	4G51-1855	74-75	DID	MS2	MS-502	MS-500NS	MS-500PP		
16L	4G32-1597	71-72	DID	MS2	MS-502	MS-500NS	MS-500PP		
16L A53	4G32-1597	72-73		A1x2	AN-119				
1800 SH3	4G63-1997	93-	DIDTF	MS2	MS-511	MS-511NS	MS-500PP		
Lancer									
GL	4G13-1298	89-92	C26	A2	AN-124NZ	AN-124NS	AN-107PP		
GLX	4G15-1468	89-92	C26	A2	AN-124NZ	AN-124NS	AN-107PP		
GL LQ-LR-LS	4G32-1597	79-82	C26	A2	AN-124NZ	AN-124NS	AN-107PP		
GL LQ-LR-LS	4G11-1244	79-82	C26	A2	AN-124NZ	AN-124NS	AN-107PP	Cont\	









Notes:

Carburettor Repair Kits & Parts

 Make & Model	 Eng Size	 Year	 Carb. Model	Type of carb. No. of barrels No. of carbs	 Repair Kit	 Needle & Seat	 Pump Plunger	 Choke Pull Off
MITSUBISHI PASSENGER (Continued)								
Lancer Cont.)								
GL NA	4G36-1238	75-76	DID	MS2	MS-502	MS-500NS	MS-500PP	
GL NB-LN-LP	4G32-1597	77-78	DID	MS2	MS-502	MS-500NS	MS-500PP	
GL NB-LN-LP	4G36-1238	77-78	DID	MS2	MS-502	MS-500NS	MS-500PP	
Magna								
TM, TN Leaded	4G63-2000	2/82-9/87	DIDTA	MS2	MS-505ANZ	MS-505NS	MS-500PP	MS-500CP
TN, TP, TR (unleaded)	4G54B-2555	10/87 on	DIDTF	MS2	MS-511	MS-511NS	MS-500PP	MS-500CP
Mirage								
II Geneva MT/VW/X	4G11-1244	83-85	C26	A2	AN-124NZ	AN-124NS	AN-107PP	
II Geneva MT/VW/X	4G12-1410	83-85	C26	A2	AN-124NZ	AN-124NS	AN-107PP	
II Geneva MY/Z/A	4G15-1468	86 on	C26	A2	AN-124NZ	AN-124NS	AN-107PP	
II Geneva MY/Z/A	4G13-1298	86 on	C26	A2	AN-124NZ	AN-124NS	AN-107PP	
MP-MQ	4G11-1244	79-80	C26	A2	AN-107NZ	AN-107NS	AN-107PP	
MP-MQ	4G12-1410	79-80	C26	A2	AN-107NZ	AN-107NS	AN-107PP	
MR-MS	4G11-1244	81-82	C26	A2	AN-124NZ	AN-124NS	AN-107PP	
MR-MS	4G11-1410	81-82	C26	A2	AN-124NZ	AN-124NS	AN-107PP	
Sigma								
Estate GN 4G54	4G54-2555	84-86	DIDTA	MS2	MS-505ANZ	MS-505NS	MS-500PP	MS-505CP
FWD GW-GX-GY 4G37	1755cc	84-86	C26	A2	AN-124NZ	AN-124NS	AN-107PP	
FWD GW-GX-GY 4G63	1997cc	84-86	C26	A2	AN-124NZ	AN-124NS	AN-107PP	
FWD GX Cyclone	4G63-1997	87-89	C26	A2	AN-124NZ	AN-124NS	AN-107PP	
FWD GX Cyclone	4G37-1755	87-89	C26	A2	AN-124NZ	AN-124NS	AN-107PP	
GR-GS-GT-GV	4G52-1597	80-84	C26	A2	AN-124NZ	AN-124NS	AN-107PP	
GR-GS-GT-GV	4G63-1997	80-84	C26	A2	AN-124NZ	AN-124NS	AN-107PP	
YC-GN-GP-GQ	4G32-1597	77-80	DID	MS2	MS-502	MS-500NS	MS-500PP	
YC-GN-GP-GQ	4G37-1755	77-80	DID	MS2	MS-502	MS-500NS	MS-500PP	
YC-GN-GP-GQ	4G52-1995	77-80	DID	MS2	MS-502	MS-500NS	MS-500PP	
Tredia								
TT-TV Turbo	4G32T-1597	83-84	DIDTA	MS2	MS-505ANZ	MS-505NS	MS-500PP	
TT-TV-TX-TZ	4G32-1597	83-87	C26	A2	AN-124NZ	AN-124NS	AN-107PP	
TX-TZ	4G62-1755	83-87	C26	A2	AN-124NZ	AN-124NS	AN-107PP	
MITSUBISHI COMMERCIAL								
Canter								
FC211,212	G63B-1997	78-81	213324	N2	NK-563A	NK-563NS	NK-556PP	NK-563CP
T210,215,217	G54B-2555	86-92	DIDTF	MS2	MS-511	MS-511NS	MS-500PP	MS-500CP
T93, T97	4G53-2384	79-4/86	DIDTA	MS2	MS-500B	MS-500NS	MS-500PP	MS-500CP
		78 on	DIDTA	MS2	MS-500B	MS-500NS	MS-500PP	MS-500CP
L200								
4x4 L021-L022	4G63-1997	84-85	C26	A2	AN-124NZ	AN-124NS	AN-107PP	
4x4 L037	4G63-1997	86-on	C26	A2	AN-124NZ	AN-124NS	AN-107PP	
K02-K12	4G62-1997	86-on	C26	A2	AN-124NZ	AN-124NS	AN-107PP	
K13	4G54-2555	87-on	DIDTA	MS2	MS-505ANZ	MS-505NS	MS-500PP	MS-505CP
L021	4G32-1597	79-80	C26	A2	AN-107NZ	AN-107NS	AN-107PP	
L021	4G32-1597	81-82	C26	A2	AN-124NZ	AN-124NS	AN-107PP	
L022	4G52-1955	81-82	C26	A2	AN-124NZ	AN-124NS	AN-107PP	
L026	4G63-1997	82-86	C26	A2	AN-124NZ	AN-124NS	AN-107PP	
L032	4G32-1597	82-87	DIDTA	MS2	MS-505ANZ	MS-505NS	MS-500PP	MS-505CP
L065	4G62-1755	85-87	C26	A2	AN-124NZ	AN-124NS	AN-107PP	

Notes:

Carburettor Repair Kits & Parts

 Make & Model	 Eng Size	 Year	 Carb. Model	Type of carb, No. of barrels No. of carbs	 Repair Kit	 Needle & Seat	 Pump Plunger	 Choke Pull Off
MITSUBISHI COMMERCIAL (Continued)								
L300								
4x4 P23	4G63-1997	85-on	C26	A2	AN-124NZ	AN-124NS	AN-107PP	
Cyclone L035	4G62-1775	87-on	C26	A2	AN-124NZ	AN-124NS	AN-107PP	
Cyclone PO	4G63-1997	87-on	C26	A2	AN-124NZ	AN-124NS	AN-107PP	
L031	4G32-1597	80-81	C26	A2	AN-107NZ	AN-107NS	AN-107PP	
L031	4G32-1597	82-85	C26	A2	AN-124NZ	AN-124NS	AN-107PP	
L032	4G63-1997	86-87	C26	A2	AN-124NZ	AN-124NS	AN-107PP	
Pajero								
NA,NB,NC,ND 4WD	4G54-2555	82-87	DIDTA	MS2	MS-500B	MS-500NS	MS-500PP	MS-500CP
NE,NF,NH 4WD	G54B-2555	87 on	DIDTF	MS2	MS-511	MS-511NS	MS-500PP	MS-500CP
Triton								
MF 2WD	4G54-2555	88 on	DIDTF	MS2	MS-511	MS-511NS	MS-500PP	MS-500CP
Ute ME/F/G/H 4WD	4G54-2555	10/86 on	DIDTA	MS2	MS-505ANZ	MS-505NS	MS-500PP	MS-505CP
MORGAN								
4/4 Ford Engine								
	1598	71-80	32/36DGV	W2	WE-800	WE-800NS	WE-800PP	
	1598	68-70	32DFM	W2	WE-802	WE-800NS	WE-802PP	
	1587	81 on	32ADF	W2	WE-810	WE-800NS		
	1598	81 on	32/34DFT	W2	WE-813	WE-800NS	WE-802PP	
Plus 4								
Tri-TR3 Engine	1991	55-62	H4	SU1x2	SU-765	SU-750NS		
Tri-TR4 Engine	2138	61-67	CD175	CD1x2	CD-201	CD-201NS	CD-201PP	
Tri-TR4 Engine	2138	61-67	HS6	SU1x2	SU-754	SU-750NS		
Plus 8 Rover Engine								
	V8-3525	82 on	CDE175	CD1x2	CD-206	CD-201NS	CD-201PP	
	V8-3525	67-72	HS6	SU1x2	SU-754	SU-750NS		
	V8-3525	72-81	HIF6	SU1x2	SU-760	SU-750NS		
NISSAN								
1000,1200,120Y,Sunny	998-1488	67-79	DCG306	Hi2	HT-412	HT-412NS	HT-412PP	
1000,B10,VB10	1000	67-71	DCG306	Hi2	HT-412	HT-412NS	HT-412PP	
100A Cherry	1000	7/76-6/80	DCG306	Hi2	HT-412	HT-412NS	HT-412PP	
1200 B110	1200	70-74	DCG306	Hi2	HT-412	HT-412NS	HT-412PP	
120Y B210	1200	74-79	DCG306	Hi2	HT-412	HT-412NS	HT-412PP	
1300 Bluebird P411	1299	65-67		Hi2	HT-408			
140J Violet	1400	73-74	213304	N2	NK-556	NK-550NS	NK-556PP	
1600 P510	L16-1595	68-72	DAF328	Hi2	HT-400	NK-566NS	NK-566PP	
1600SSS, 180BSSS	1595-1770	74-76	JHL38W	Hi1x2	HT-416*			
180B P610	L18-1770	72-78	213304	N2	NK-556	NK-550NS	NK-556PP	
200B,SX,SSS N810	L20-1952	78-81	DCM-340,21A-304	Hi2/N2	NK-566B	NK-566NS	NK-566PP	see note (8)
240C P230	L24-2393	71-73	DAF342	Hi2	HT-400	NK-566NS	NK-566PP	
	L24-2393	73-76	DAH342	N2	NK-566B	NK-566NS	NK-566PP	see note (8)
	L24-2393	71-73	DAF-342	Hi2	HT-400	NK-566NS	NK-566PP	
240K C110								
	L24-2393	73-76	DAF342	Hi2	HT-400	NK-566NS	NK-566PP	
	L24-2393	4/76-78	DAH342	N2	NK-566B	NK-566NS	NK-566PP	see note (8)
240Z S30								
	L24-2393	70-8/71	HJG46W	Hi1x2	HT-405			
	L26-2565	71-73	HJG46W	Hi1	HT-406 (F)			
	L26-2565	71-73	HJG46W	Hi1	HT-407 (R)			

Notes:









8 NK-566CP, NK566CPL refer to page 6

* HT416 is also available in a major kit HT-416X includes main jet refer to page 61

(F) Front Carburettor

(R) Rear Carburettor







Carburettor Repair Kits & Parts

								
Make & Model	Eng Size	Year	Carb. Model	Type of carb. No. of barrels No. of carbs	Repair Kit	Needle & Seat	Pump Plunger	Choke Pull Off
NISSAN (Continued)								
260C H230-H330								
	L26-2565	76-77	DAF342	Hi2	HT-400	NK-566NS	NK-566PP	
	L26-2565	78-80	DAH342	N2	NK-566B	NK-566NS	NK-566PP	see note (8)
260Z	L26-2565	74-78	HMB46W	Hi1x2	HT-414			
280C 330,340	L28-2753	5/81-83	DAF342	N2	NK-566B	NK-566NS	NK-566PP	see note (8)
Bluebird								
<i>F310/11/12,410</i>	E1-1189	11/61-68	D2630A	N2	NK-550	NK-550NS	NK-550PP	
Ser.1,2,3 <i>J910</i>	1952-1974	80-85	DCR340/342	N2	NK-566B	NK-566NS	NK-566PP	see note (8)
U11	1600	86-89		N2	NK-584			
U12	2000	86-89		N2	NK-583			
Brougham	L26-2565	7/80-5/81	DAH-342	Hi2/N2	NK-566B	NK-566NS	NK-566PP	see note (8)
Cedric								
<i>P31</i>	H-1883	63-65	213304	N2	NK-556	NK-550NS	NK-556PP	
Langley								
<i>E15</i>	1487,1598	84-87		Hi2	HT-429			
Laurel		6/81-84	DAH-342	Hi2/N2	NK-566B	NK-566NS	NK-566PP	see note (8)
Pulsar								
<i>N10</i>	A14-1397	10/80-12/81	DCG306	Hi2	HT-412	HT-412NS	HT-412PP	
<i>N10</i>	E15-1488	10/81-6/82	DCF,DCZ306	Hi2	HT-420	HT-412NS	HT-420PP	
<i>N10</i>	E13-1270	10/81-82	217260	N2	NK-569A			
<i>N12</i>	E15-1488	82-84	DCZ306	Hi2	HT-424	HT-412NS	HT-420PP	
<i>N12</i>	E16-1597	4/82 on	DCZ306	Hi2	HT-424	HT-412NS	HT-420PP	
<i>N12</i>	1488	85-87		Hi2	HT-420			
Sentra								
<i>N13</i>	E13-1300	87-89		N2	NK-569B			
<i>N13</i>	E16-1600	87-89	DCZ-306	Hi2	HT-424	HT-412NS	HT-420PP	
<i>N13</i>	E16-1600	89-91		Hi2	HT-429			
Sunny								
1200 Sedan & Coupe	A12-1171	79-7/81	DCG306	Hi2	HT-412	HT-412NS	HT-412PP	
1400 1500 <i>B-310</i>	A14-15	78-7/81	DCG306	Hi2	HT-412	HT-412NS	HT-412PP	
1500	A14-1488	10/84	DCZ-306	Hi2	HT-424	HT-412NS	HT-420PP	
Sports Wagon 1300	E13-1270	7/83	217260	N2	NK-569A			
1300 <i>B1161</i>	E13-1270	82-87		N2	NK-569B			
NISSAN COMMERCIAL								
1/2 Ton Pick-Up	A12-1171	81-84	DCG306	Hi2	HT-412	HT-412NS	HT-412PP	
1200 Van	A12-1171	72-74	DCG306	Hi2	HT-412	HT-412NS	HT-412PP	
120Y Van; Sunny Van	A12-1171	74-83	DCG306	Hi2	HT-412	HT-412NS	HT-412PP	
1300,1500								
520,521,620	1299,1483	5/68 on	215282	N2	NK-550	NK-550NS	NK-550PP	
1500 Ute								
620	J15-1483	8/75 on	DCH340	N2	NK-566B	NK-566NS	NK-566PP	see note (8)
4x4 Utility	2188	84-86		N2	NK-566B	NK-566NS	NK-566PP	see note (8)
Beach Comber Ute	1770	82-83	DCH-340	Hi2	NK-566B	NK-566NS	NK-566PP	see note (8)
Bluebird GX Van	1952	81-84	DCH-340	Hi2/N2	NK-566B	NK-566NS	NK-566PP	see note (8)
Superwagon, Vanette								
<i>C20</i>	1487	82-83	DCF-306	Hi2	HT-420	HT-412NS	HT-420PP	

Notes:

8 NK-566CP, NK566CPL refer to page 6









Carburettor Repair Kits & Parts

 Make & Model	 Eng Size	 Year	 Carb. Model	Type of carb. No. of barrels No. of carbs	 Repair Kit	 Needle & Seat	 Pump Plunger	 Choke Pull Off
NISSAN COMMERCIAL (Continued)								
Van								
C20	1171,1487	80-83	DCG306	Hi2	HT-412	HT-412NS	HT-412PP	
Vanette								
C20	1487	83-	DCR-306	Hi2	HT-420	HT-412NS	HT-420PP	
Caball	1982	70-80	213304	N2	NK-566B	NK-566NS	NK-566PP	
3.5 Ton								
C80	3000	68-76	VHA42	Hi2	HT-410			
Caball Junior								
C240,340	H20-1982	All	213304	N2	NK-556	NK-550NS	NK-550PP	
Kingcab 720,								
4WD	L18-1770	79-85	DCH340	N2	NK-566B	NK-566NS	NK-566PP	see note (8)
Navara								
4WD	Z24-2389	to 86		N2	NK-566B	NK-566NS	NK-566PP	see note (8)
D21	Z20-1952	86-88		N2	NK-566B	NK-566NS	NK-566PP	see note (8)
D21	Z24-2389	88-		N2	NK-579			
Nissan Van,Bus								
E20	J18-1589	74-1/77	215282	N2	NK-550	NK-550NS	NK-550PP	
E20	H20-1982	2/77-80	21A304	N2	NK-566B	NK-566NS	NK-566PP	see note (8)
One Ton Ute								
B20	1483	72-78		N2	NK-550	NK-550NS	NK-550PP	
720	1483	79-82		Hi2	NK-556B	NK-550NS	NK-556PP	see note (8)
720	1770	83-86	DCH-340	Hi2	NK-566B	NK-566NS	NK-566PP	see note (8)
Pathfinder 4WD								
WD21	Z24-2389	to 11/87		N2	NK-566B	NK-566NS	NK-566PP	see note (8)
WD21	Z24-2389	12/87 on	DCR384-42	N2	NK-579			
Patrol								
	3965	61-68	7015013	R1	RT-600			
	2753	83 on		N2	NK-566B	NK-566NS	NK-566PP	see note (8)
P40	3956	85 on		N2	NK-574	NK-566NS	NK-566PP	
G60 4WD	P-3956	61-2/69	VC42	Hi2	HT-409			
G60 4WD	3965	69-81	VHA,VHB-42	Hi1	HT-410			
G61 4WD	P-3956	3/69-80	VHA/B42	Hi2	HT-410			
GQ 4WD Y60	4169	2/88-92		N2	NK-577			
MQ	3965	81-85	DAF-342	Hi2	NK-566B	NK-566NS	NK-566PP	see note (8)
MQ 4WD 160	L28-2753	81-87		N2	NK-566B	NK-566NS	NK-566PP	see note (8)
MQ 4WD 160	P40-3956	7/85 on		N2	NK-574	NK-566NS	NK-566PP	
Roadstar & Sportstar	A12-1171	81-84	DCG306	Hi2	HT-412	HT-412NS	HT-412PP	
Spacevan,Bus	1724	78-79	21A-304	N2	NK-566B	NK-566NS	NK-566PP	see note (8)
Urvan								
(with J16,H20 eng.)	1567,1952	81-90	DCH340	N2	NK-566B	NK-566NS	NK-566PP	see note (8)
E23	Z24-2389	87 on		N2	NK-579			
Microbus	1952	85-86	DCH-340	Hi2/N2	NK-566B	NK-566NS	NK-566PP	see note (8)
Van								
C30	R-1595	69-71	DAF342	Hi2	HT-400	NK-566NS	NK-566PP	
Vanette								
C22	1500	89-92	DCZ306	Hi2	HT-424	HT-412NS	HT-420PP	

Notes:









8 NK-566CP, NK566CPL refer to page 6

Carburettor Repair Kits & Parts

				Type of carb, No. of barrels				
Make & Model	Eng Size	Year	Carb. Model	Type of carb, No. of barrels	Repair Kit	Needle & Seat	Pump Plunger	Choke Pull Off
PEUGEOT								
203	1290	49-56	32PBIC	SL1	SX-736	SX-700NS		
203, 403	1290,1468	49-58	32PBIC	SL1	SX-736	SX-700NS		
204	1130	66-70	32PBISA	SL1	SX-7063			
304	1288	70-78	34PBSIA	SL1	SX-7063			
305								
SR	1472	79-81	35PBSIA	SL1	SX-7063			
403								
	1290	66-67	32PBSIA	SL1	SX-719			
	1468	66-67	32PBSIA	SL1	SX-719			
403,504GL	1796	58-71	32/34PBICA	SL2	SX-719			
404								
	1618	60-70	32/34PBICA	SL2	SX-719			
	1618	60-75	34PBSIA	SL1	SX-719			
404-8	XC-6/1618	10/67-72	34BICSA	SL1	SX-740			
504	1796	70-75	34PBICA	SL1	SX-719			
	1971	70-74	32/35SEIEA	SL2	SX-720A			
	1971	75-81	32/35TMIMASA	SL2	SX-730A			
	1796	6/75-80	34BICSA	SL1	SX-740			
	1971	74-81	35/40INAT	Z2	ZE-865			
GL	1971	71-76	32/35SEIEA	SL2	SX-720A			
504,505	1971	77-86	35-35TMIMA	SL2	SX-730A			
505								
Estate	1971	87 on	34BICSA	SL1	SX-740			
GR/SR	1971	79-84	32/35TMIMA	SL2	SX-730A			
604								
	2664	77-85	34TBIA	SL1	SX-729			
	V6-2664	75-81	34TBIA2	SL1	SX-729A (F)			
	V6-2664	75-81	35CEEI	SL1	SX-741 (R)			
PONTIAC								
Le Mans								
K01-K04	1498	88-90		A2	AN-100A	AN-100NS	AN-100PP	
PORSCHE								
1500,1600								
4 Cyl.	1582	51-56	32PBIC	SL1x2	SX-736	SX-700NS		
1500S,1600S								
4 Cyl.	1582	51-56	40PBIC	SL1x2	SX-739	SX-700NS		
1600								
Normal, Super	1582	57-65	32NDIX	Z2x2	ZE-861			
Super 90	1582	60-6/69	40P11	SL1x2	SX-748			
904 GTS Carrera								
4 Cyl.	1956	64-65	46IDA	W2x2	WE-848			
911T								
6 Cyl.	2195,2341	9/69-8/73	40TIN	Z3x2	ZE-862			
912								
4 Cyl.	1582	65-9/69	40P11	SL2x2	SX-748			
Carrera								
356A,B,C	1582	58-6/69	40P11	SL2	SX-748			









Notes:
(F) Front Carburettor
(R) Rear Carburettor

Carburettor Repair Kits & Parts

				Type of carb. No. of barrels No. of carbs				
Make & Model	Eng Size	Year	Carb. Model		Repair Kit	Needle & Seat	Pump Plunger	Choke Pull Off
PRINCE								
Gloria 6	1988	8/64-5/67	DAF328	H12	HT-400	NK-566NS	NK-566PP	
Prince								
A200-GT	1988	8/65-66	40DCOE	W2x3	WE-805	WE-805NS		
Skyline								
A150	1484	9/64-6/67	213304	N2	NK-556	NK-550NS	NK-566PP	
G11	2.5L	66	40DCOE	W2x3	WE-805	WE-805NS		
PROTON								
Saga	1298	87-93		A2	AN-124ANZ	AN-124NS	AN-124PP	
	1498	87-93		A2	AN-124ANZ	AN-124NS	AN-124PP	
RAMBLER								
199,232,258 CID 6 Cyl.		70-76	YF	C1	CA-158			
232,258 CID 6 Cyl.		56-70	WCD	C2	CA-161			
250,287,327 CID V8		60-65	2300	H2	HY-353	HY-350NS	HY-350PP	
287,290,343 CID V8		65-67	2209	H2	HY-383			
290,304,343,360,401 V8		68-79	2100	F2	FD-301	FD-301NS	FD-301PP	FD-301CP
290,343,390 CID V8			AFB	C4	CA-167			
304,350,360,390,401 V8		70-73	4160	H4	HY-350	HY-350NS	HY-350PP	
304,360 V8		77-78	2150	F2	FD-306A	FD-301NS		
360,390,401 CID V8		70-74	4300	F4	FD-304	FD-304NS	FD-304PP	
360,401 CID V8		75-76	4350	F4	FD-305	FD-304NS		
RENAULT								
16								
TX	1647	75-76	32DAR	W2	WE-8096	WE-800NS	WE-800PP	
17								
TL	1565	73-76	32DIR	W2	WE-811A	WE-800NS	WE-802PP	WE-811CP
18								
GTS	1647	79-82	35EITA	SL1	SX-7113			
Turbo	1565	81-83	32DIS	SL1	SX-7092			
20								
TS	1995	78-83	32DARA	W2	WE-8072	WE-800NS	WE-802PP	
TX	2165	81-83	32/36DARA	W2	WE-8072	WE-800NS	WE-802PP	
21								
GTS	1721	86 on	28/34Z10	SL2	SX-7115			
25								
	1995	84-87	32/36DARA	W2	WE-8072	WE-800NS	WE-802PP	
	2165	85-87	32/36DARA	W2	WE-8072	WE-800NS	WE-802PP	
30								
TS	2664	77-82	38DGAR	W2	WE-8073	WE-800NS	WE-800PP	
Espace	1995	85 on	32DARA	W2	WE-8072	WE-800NS	WE-802PP	
Fuego								
	1995	81-86	32DARA	W2	WE-8072	WE-800NS	WE-802PP	
	1647	81-86	32DIR	W2	WE-811A	WE-800NS	WE-802PP	WE-811CP
GTX, TX	1995	82-87	32DARA58	W2	WE-8072	WE-800NS	WE-802PP	
Turbo	1565	84-86	32DIS	SL1	SX-7092			
Turbo	1565	84-86	32DIS	SL1	SX-7092			









Notes:

Carburettor Repair Kits & Parts

				Type of carb. No. of barrels No. of carbs				
Make & Model	Eng Size	Year	Carb. Model		Repair Kit	Needle & Seat	Pump Plunger	Choke Pull Off
RENAULT (Continued)								
R12,R14								
Virage	1397	76-80	32DIR	W2	WE-811A	WE-800NS	WE-802PP	WE-811CP
R12,R15TS								
Coupe	1397,1565	73-80	32DIR	W2	WE-811A	WE-800NS	WE-802PP	WE-811CP
R12GL								
TL,XL	1289	70-76	32EISA	SL1	SX-723			
R16	1565	73-74	32EISA	SL1	SX-723			
R16-17								
TS,TL	1565	68-77	32DIR	W2	WE-811A	WE-800NS	WE-802PP	WE-811CP
R18GTS,R20TS	1647,1995	79-83	32DARA	W2	WE-8072	WE-800NS	WE-802PP	
R5	1289	76 on	32DIR	W2	WE-811A	WE-800NS	WE-802PP	WE-811CP
ROVER								
2000	1994	1/82-86	HIF44	SU1x2	SU-756	SU-756NS		
SC & Auto	1978	10/63-9/73	HS6	SU1	SU-754	SU-750NS		
TC	1978	67-9/73	HS8	SU1x2	SU-774	SU-750NS		
213	1342	84-86	DA76B	K2	KN-450	KN-450NS	KN-450PP	
2200								
SC,TC	2205	10/73-7/77	HIF6	SU1x2	SU-760	SU-750NS		
2300	2351	1/82-86	HIF44	SU1x2	SU-756	SU-756NS		
	2351	10/77-81	HS6	SU1x2	SU-769	SU-750NS		
3500								
V8	3528	1/80 on	CDE175	CD1x2	CD-206	CD-201NS	CD-201PP	
V8	3528	4/68-72	HS6	SU1x2	SU-754	SU-750NS		
V8	3528	72-80	HIF6	SU1x2	SU-760	SU-750NS		
Quintet								
(Honda Engine)	EL-1602	5/83-3/86	DA76B	K2	KN-450	KN-450NS	KN-450PP	
SDI								
6 Cyl	2597	76-81	HS6	SU1x2	SU-769	SU-750NS		
V8	3528	76-86	HIF6	SU1x2	SU-760	SU-750NS		
RANGE ROVER - LAND ROVER								
1.6L								
4 Cyl.	1600	45-58	32PBI	SL1	SX-736	SX-700NS		
109								
(4WD) V8	3528	78 on	CDSE,CD3	CD1x2	CD-201	CD-201NS	CD-201PP	
	2286	67-84	36 IV	Z1	ZE-852	ZE-852NS		
V8	3528	78-84	175 CDSE	CD1x2	CD-201	CD-201NS	CD-201PP	
110								
(4WD) V8	3528	3/83 on	CDSE,CD3	CD1x2	CD-201	CD-201NS	CD-201PP	
(4WD) V8	3528	3/83 on	CDSE,CD3	CD1x2	CD-205		CD-201PP	
(4WD) 2-1/4L 6 Cyl	2250	3/83 on	32/34DMTL	W2	WE-8074	WE-800NS	WE-802PP	
2 1/4 Litre								
	2286	55-67	40 PAIO	SL1	SX-735	SX-700NS		
	2286	67-2/83	36 IV;36 IVE	Z1	ZE-852	ZE-852NS		
2.6 Litre								
	2625	67-80	175 CDS/AE	CD1	CD-201	CD-201NS	CD-201PP	
	2625	63-67	HD6	SU1	SU-763	SU-750NS		
2.6 Litre	2625	67-69	HD8	SU1	SU-764	SU-750NS		
3.5 L								
V8	3528	78 on	CDSE,CD3	CD1x2	CD-201	CD-201NS	CD-201PP	









Notes:

Carburettor Repair Kits & Parts

 Make & Model	 Eng Size	 Year	 Carb. Model	Type of carb. No. of barrels No. of carbs	 Repair Kit	 Needle & Seat	 Pump Plunger	 Choke Pull Off
RANGE ROVER - LAND ROVER (Continued)								
88	2286	67-84	36 IV	Z1	ZE-852	ZE-852NS		
88, 109	2286	67 on	36IV	Z1	ZE-852	ZE-852NS		
One Ten 2 1/4 Litre	2286	3/83	32/34 DMTL	W2	WE-8074	WE-800NS	WE-802PP	
One Ten 3 1/2 Litre	3528	3/83	175 CDSE,CD3		CD1x2	CD-201	CD-201NS	CD-201PP
Range Rover								
V8	3528	70-81	CDS,SE,SEV	CD1x2	CD-201	CD-201NS	CD-201PP	
V8	3528	82-	175CDTEF	CD1x2	CD-206	CD-201NS		
SAAB								
99								
B20	1709,1854	66-77	CD-2SE	CD1x2	CD-205	ZE-864NS	CD-201PP	
B20,BT20		75-78	CD150	CD1x2	CD-200	CD-200NS	CD-200PP	
SKODA								
105								
S	1046	76-79	32 EDSR	JK2	XA-0100			
110								
L.L.S.R	1107	76-77	32 EDSR	JK2	XA-0100			
120								
L	1174	86 on	32 EDSR	JK2	XA-0100			
STUDEBAKER								
Golden Hawk								
S/Chgd	289ci	57-58	WW	S2	SB-660	SB-651NS		
Lark,Avanti		63-64	AFB	C4	CA-167			
Sedan								
	283ci	65	2GV	R2	RT-605	RT-605NS		
	283ci	65	4GC	R2	RT-612			
Sedan,Truck								
V8		55-60	WCFB	C1	CA-163			
SUBARU								
1400								
Coupe,GFT,GSR 5sp	EA63-1361	75-76	DCG306W	Hi2x2	HT-413	HT-412NS	HT-412PP	
Sedan,Wagon,2/4WD	EA63-1361	7/73-4/76	DCG306	Hi2	HT-413	HT-412NS	HT-412PP	
1600								
GF & GFT Coupe		76-79	DCG-306	Hi2	HT-413	HT-412NS	HT-412PP	
Leone,Brumby 4WD	EA71-1595	10/79-8/81	DCJ/306	Hi2	HT-421A	HT-412NS	HT-412PP	
Sedan,Coupe,H/Top	EA71-1595	5/76-78	DCG/J306	Hi2	HT-413	HT-412NS	HT-412PP	
Wagon,2WD,4WD	EA71-1595	5/76-10/79	DCG/J306	Hi2	HT-413	HT-412NS	HT-412PP	
1800								
Brumby	EA81-1781	82 on	DCJ306	Hi2	HT-421A	HT-412NS	HT-412PP	
Brumby	EA81-1781	83 on	DCK501	Hi2	HT-425		HT-412PP	
Dual-Range	EA82-1781	84-86	DCX	Hi2	HT-421A	HT-412NS	HT-412PP	
Dual-Range,Wagon	EA81-1781	81-8/83	DCM306	Hi2	HT-421A	HT-412NS	HT-412PP	
Leone,Brumby 4WD	EA81-1781	82 on	DCK328	Hi2	HT-425		HT-412PP	
RX Coupe 4WD		83-84	DCX-328	Hi2	HT-425		HT-412PP	









Notes:

Carburettor Repair Kits & Parts

 Make & Model	 Eng Size	 Year	 Carb. Model	Type of carb. No. of barrels No. of carbs	 Repair Kit	 Needle & Seat	 Pump Plunger	 Choke Pull Off
SUBARU (Continued)								
Ace								
KG5	758	90-92		N2	NK-569B			
KG3	665	1989		N2	NK-569B			
Justy	1200	86 on	DCX-306	Hi2	NK-569A			
4WD	997	84-86	DCX-306	Hi2	NK-569A			
Legacy	1820	89-93		Hi2	HT-430			
Leone								
1.8 GF & 4WD	1800	85 on	DCX-328	Hi2	HT-425		HT-412PP	
1400 DL	1400	72-76	DCG-306	Hi2	HT-413	HT-412NS	HT-412PP	
1600 DL	1600	77-80	DCG/J-306	Hi2	HT-413	HT-412NS	HT-412PP	
1800 GLF5	1600	80-81	DCG/J-306	Hi2	HT-413	HT-412NS	HT-412PP	
1600 GLF5	1600	82-85	DCJ/P-306	Hi2	HT-421A	HT-412NS	HT-412PP	
1800 & 4WD	1800	80-81	DCG/J-306	Hi2	HT-413	HT-412NS	HT-412PP	
1800 GLF & 4WD	1800	82-85	DCM-306	Hi2	HT-421A	HT-412NS	HT-412PP	
Omega								
JF1AC2	1595	89		Hi2	HT-425			
JFAC4	1781	88-89		Hi2	HT-425			
4WD	1781	88-89		Hi2	HT-425			
Sherpa	758	89 on		N2	NK-569B			
2 Cyl.	665	10/82-89	217260	N2	NK-569B			
SUZUKI								
Alto Hatch	543,796	10/86 on	24/32DIDS	MS2	MS-504			MS-500PP
Hatch								
SS40V,SS80V	543,796	80-81 on	24/32DIDS	MS2	MS-504			MS-500PP
Mighty Boy								
	F8A-997	79-85	30-PHD	MS1	MS-501	MS-500NS		MS-500PP
	F5A-543	7/85-10/88		MS1	MS-506			MS-500PP
SS40	F5A-543	85 on	24/32DIDS	MS2	MS-504			MS-500PP
Swift								
SA,SF	G10-993	85 on		A2	AN-124NZ	AN-124NS		AN-107PP
SF 413	G13B-1298	11/90 on		A2	AN-127			
SJ50	G13A-1324	3/84 on		A2	AN-124NZ	AN-124NS		AN-107PP
SF416	1590	90-		MS2	MS-513			
SUZUKI COMMERCIAL								
Carry								
ST80,ST90V	F8A-997	79-85	30PHD	MS1	MS-501	MS-500NS		MS-500PP
ST90	F8A-997	80 on	79200	MS1	MS-506			MS-500PP
Sierra								
4WD SJ410	F10A-970	9/81 on	80020	A1	AN-122			
4WD SJ413	G13A-1324	2/85 on	82630	A2	AN-124NZ	AN-124NS		AN-107PP
4WD SJ51T	G13B-1298	86 on		A2	AN-124NZ	AN-124NS		AN-107PP
ST-10,ST-20								
(2 Stroke)	539-550	to 3/74		MS1	MS-507			MS-500PP
ST10A								
From Eng. 752981	F8A-997	77-81		MS1	MS-506			MS-500PP









Notes:

Carburettor Repair Kits & Parts

 Make & Model	 Eng Size	 Year	 Carb. Model	Type of carb. No. of barrels No. of carbs	 Repair Kit	 Needle & Seat	 Pump Plunger	 Choke Pull Off
SUZUKI COMMERCIAL (Continued)								
Stockman								
LJ50,LJ50V	LJ50-539	4/74-12/77		HI1	HT-411			
LJ80,81-1	F8-797	11/77-9/81	73010/11	MS1	MS-501	MS-500NS	MS-500PP	
LJ81-2	F8-797	12/79 on	73010	MS1	MS-506		MS-500PP	
Super Carry	F10A-970	10/86 on	85220	MS1	MS-506		MS-500PP	
4WD ST40V				A1	AN-122			
Vitara								
JLJLX	G16A-1590	7/88-8/91		MS2	MS-513			
Samurai								
ST413	1324	88-89		A2	AN-124NZ	AN-124NS	AN-107PP	
TALBOT								
Alpine								
GLS	1442	5/80-2/82	36 DCNH	W2	WE-838	WE-805NS	WE-802PP	
GLS,LE (Chrysler Alpine)	1442	77-4/80	36 DCNVA	W2	WE-827	WE-805NS	WE-802PP	
SX	1592	3/82-84	36 DCNVH	W2	WE-8078	WE-805NS	WE-802PP	
TOYOTA PASSENGER								
Camry								
SV20,21,22	1SE-1998	89 on	31720/74110	A2	AN-121	AN-121NS	AN-121PP	AN-121CP
Celica								
Twin Cam Imp.	20RG-1587		44PHH	SL2x2	MS-509	SX-700NS		
Coupe RA23,28	18R-1968	74-8/77	34243,34244	A2	AN-108	AN-108NS	AN-100PP	
Coupe TA22,23	2T-1588	74-7/77	16480, 26112/162181	A2	AN-100A	AN-100NS	AN-100PP	
Coupe TA22	2T-1588	70-73		A2	AN-113A	AN-113NS	AN-100PP	
Liftback RA60	21R-1972	81-85	37120	A2	AN-121	AN-121NS	AN-121PP	AN-121CP
Liftback XT RA40	18R-1968	77-10/81	34400,34401	A2	AN-111	AN-108NS	AN-100PP	AN-111CPA
Liftback XT TA40	2TG-1588	74-80		A2	AN-100A	AN-100NS	AN-100PP	
Corolla								
KE10	1100	11/66-8/68		A2	AN-106A	AN-106NS		
KE11,20,25	1200	70-12/71	24030	A2	AN-101	AN-100NS	AN-100PP	
KE20,25,30,36	1200	2/80 on	13860,24033,24372	A2	AN-107NZ	AN-107NS	AN-107PP	
KE35	1200	75-80		A2x2	AN-107NZ	AN-107NS	AN-107PP	
F.W.D. EE80,12 V	1300	3/85-87	V.V	A1	AN-128			
KE70	1300	80-84	13340,13350	A2	AN-107NZ	AN-107NS	AN-107PP	
F.W.D. AE80,82,KE70	1600	2/84 on		A2	AN-126	AN-121NS	AN-100PP	
SE TE71	1600	80-84	26070	A2x2	AN-100A	AN-100NS	AN-100PP	
AE80	2AC-1295	85-88		A2	AN-126	AN-121NS	AN-100PP	
AE90,92,93	4AF-1297,1297	6/89 on		A2	AN-126	AN-121NS	AN-100PP	
Sprinter AE86	4AC-1587	83-84	16080/90	A2	AN-126	AN-121NS	AN-100PP	
Sprinter KE15,16	1077,1166	66-70	22050	A2x2	AN-101	AN-101NS	AN-100PP	
EE90	2E-1296	88-	V.V	A1	AN-128			
EE90	2E-1296	88-		A2	AN-107NZ	AN-107NS	AN-107PP	
Corona								
1800 RT102,117	16R-1808	74-76		A2	AN-108	AN-108NS	AN-100PP	
2000 RT104,118	18R-1968	77-79	34400,218-348	A2	AN-111	AN-108NS	AN-100PP	AN-111CPA
1500	2R-1490	64-67		A2	AN-109A	AN-109NS		
1500	2R-1490	67-69	31016/32051	A2	AN-110	AN-109NS		
1600 RT100	12R-1597	74-78		A2	AN-100A	AN-100NS	AN-100PP	Cont.









Notes:

Carburettor Repair Kits & Parts

 Make & Model	 Eng Size	 Year	 Carb. Model	 Type of carb. No. of barrels No. of carbs	 Repair Kit	 Needle & Seat	 Pump Plunger	 Choke Pull Off
TOYOTA PASSENGER (Continued)								
Corona Cont.								
1600 RT81.87	12R-1597	73-74		A2	AN-100A	AN-100NS	AN-100PP	
1600 RT81.87	12R-1597	71-72	31143,31181	A2	AN-113A	AN-113NS	AN-100PP	
1600 TT140	2T-1588	82-84		A2	AN-100A	AN-100NS	AN-100PP	
1600 XA RT130	12R-1597	80-82		A2	AN-100A	AN-100NS	AN-100PP	
1600 XR RT130	12R-1597	79-80		A2	AN-100A	AN-100NS	AN-100PP	
1700 RT84	6R-1707	71-74		A2	AN-100A	AN-100NS	AN-100PP	
1800 ST150 F.W.D	1SL-1832	84-85		A2	AN-121	AN-121NS	AN-121PP	AN-121CP
1800 TT141	3T-1770	82-84		A2	AN-111	AN-108NS	AN-100PP	AN-111CPA
1800 XT.L'back TT132	3T-1770	79-82		A2	AN-111	AN-108NS	AN-100PP	AN-111CPA
1900 XT	1X-1832	80-84	29958,23097,32088	A2	AN-100A	AN-100NS	AN-100PP	
2000 ST141	2SL-1995	85-	37160,74096,74098	A2	AN-121	AN-121NS	AN-121PP	AN-121CP
Liftback RT133	21RC-1972	82-83		A2	AN-121	AN-121NS	AN-121PP	AN-121CP
RT40,80,81	2R-1490	69-72	31092,31110	A2	AN-113A	AN-113NS	AN-100PP	
1.6XLAT171	1597	89-		A2	AN-126	AN-121NS	AN-100PP	
2.0XL ST171	1998	89-		A2	AN-126	AN-121NS	AN-100PP	
XT130,131	1892"Star"	10/79 on	32007-32082	A2	AN-126	AN-121NS	AN-100PP	
1500 RT40,80	2R-1490	69-71	31092,31110	A2	AN-113A	AN-113NS	AN-100PP	
Cressida								
2000 RX30.60	18/21R-	79-85	45271,45210	A2,N2	NK-551		AN-102PP	
Crown								
1900 RS41	3R-1897	64-66	DW35	A2	AN-114			
2000	18R-1998	5/66-1/68		A2	AN-109A	AN-109NS		
2300 MS55 & 65	2M-2253	67-3/73	45014,45015	A2	AN-116A	AN-116NS	AN-102PP	
2600 MS65	4M-2559	4/73-5/75	455060	A2	AN-102		AN-102PP	
2600 MS85 MS111	5M-2759	6/75-85	45190,45210	A2,N2	NK-551		AN-102PP	
MS83,85,111	4M-2564	6/75 on	45190/210	N2	NK-551		AN-102PP	
Starlet								
1000 DX 12V	999	86 on	10020	A2	AN-107NZ	AN-107NS	AN-107PP	
1200	1166	81-83		A2	AN-107NZ	AN-107NS	AN-107PP	
1300 GL & Sprint	1290	83-85		A2	AN-107NZ	AN-107NS	AN-107PP	
1000 & DX	993	79-85		A2	AN-107NZ	AN-107NS	AN-107PP	
T18 SE								
TE72	3T-1770	10/79-5/83	28130/31	A2	AN-126	AN-121NS	AN-100PP	
Tarago								
2000		85 on	72040	A2	AN-121	AN-121NS	AN-121PP	AN-121CP
Tercel								
1500 4WD AL25	3A-1452	85-88		A2	AN-107NZ	AN-107NS	AN-107PP	
4WD	3AC-1452	88-	16440/450	A2	AN-126	AN-121NS	AN-100PP	
Tiara								
MR2 Sports		63-64	DW35	A2	AN-114			
4 Age	1597	85-90		A2	AN-126	AN-121NS	AN-100PP	
TOYOTA COMMERCIAL								
4-Runner								
RN130	22R-2367	10/89 on		N2	NK-572A	NK-572NS		
YN60.63	1998-2237	7/84-88		A2	AN-121	AN-121NS	AN-121PP	AN-121CP









Notes:

Carburettor Repair Kits & Parts

 Make & Model	 Eng Size	 Year	 Carb. Model	Type of carb. No. of barrels	 Repair Kit	 Needle & Seat	 Pump Plunger	 Choke Pull Off
TOYOTA COMMERCIAL (Continued)								
Dyna								
YU60	2Y-1812	8/85 on		A2	AN-121	AN-121NS	AN-121PP	AN-121CP
YU62R	4Y-2237	8/86 on		N2	NK-572A	NK-572NS		
2000 RU12,20	5R-1994	72-85	44261	N2	NK-563A	NK-563NS	NK-566PP	NK-563CP
2000 YN57,65	3Y-1998	84-	71030	N2	NK-572A	NK-572NS		
Coaster RB11,13,20	2189-2366	77-80	38280/81	A2	AN-111	AN-108NS	AN-100PP	AN-111CPA
Coaster RU10,18,19	5R-1994	68-79	212325/541	N2	NK-562	NK-563NS	NK-556PP	
Coaster RU30,41,50	5R-1994	8/77-8/84		A2	AN-111	AN-108NS	AN-100PP	AN-111CPA
Hi-Ace								
1500 RH10	2R-1490	71-72	31143	A2	AN-113A	AN-113NS	AN-100PP	
1600 RH11, 20	12R-1587	72-83	31231,3191,31511	A2	AN-100A	AN-100NS	AN-100PP	
1800 YH50	2Y-1812	83-	73040	A2	AN-121	AN-121NS	AN-121PP	AN-121CP
2000 RH22	18R-1968	80-83	34512,34441	A2,N2	AN-111	AN-108NS	AN-100PP	AN-111CPA
2000 YH61	3Y-1998	83-	73040	A2	AN-121	AN-121NS	AN-121PP	AN-121CP
2200 YH63	4Y	83-	73040	A2	AN-121	AN-121NS	AN-121PP	AN-121CP
YH50,51,61,71	2Y-1998	12/82-8/86	73040	A2	AN-121	AN-121NS	AN-121PP	AN-121CP
	3Y-1998	1/86-8/88		N2	NK-572A	NK-572NS		
1300 YM20	4K-1290	81-84		A2	AN-107NZ	AN-107NS	AN-107PP	
1500 KM36	SK-1468	87-92		A2	AN-126	AN-121NS	AN-100PP	
1600 YM20	1Y-1600	84-		A2	AN-121	AN-121NS	AN-121PP	AN-121CP
YM21,30,35	2Y-1812	84-92	72140	A2	AN-121	AN-121NS	AN-121PP	AN-121CP
YM36	5KC-1486	10/85 on		A2	AN-107NZ	AN-107NS	AN-107PP	
YM40,41 4WD	5R-1994	3/86-10/88	73371	N2	NK-572A	NK-572NS		
Hi-Lux								
1600 RN25,40	12R-1587	75-83	31223,24,441	A2	AN-100A	AN-100NS	AN-100PP	
2000 SR5 YN57,65	3Y-1998	84-	71030	A2,N2	NK-572A	NK-572NS		
2000 RN41,	18R-1968	79-83	34512	A2	AN-111	AN-108NS	AN-100PP	AN-111CPA
YN57-SR5	18R-1968	82-83		N2	AN-100A	AN-100NS	AN-100PP	
Landcruiser								
FJ40,45,	55F-3955	70-75		A2	AN-103B	AN-103NS	AN-103PP	
FJ40,45,60	2F-4230	75-85	61110	A2	AN-103B	AN-103NS	AN-103PP	
FJ73,75	3955	85-9/87	211006	A2	AN-103B	AN-103NS	AN-103PP	
FJ75,FJ80R	3955	85-92		N2	AN-103B	AN-103NS	AN-103PP	
to Eng. F243298	3878	-9/69		A1	AN-118A			
Tarago								
YR20,21,22	1812,1998	2/83-88	72040	A2	AN-121	AN-121NS	AN-121PP	AN-121CP
Tercel								
AL25 4WD	3AC-1452	85-88		A2	AN-126	AN-121NS	AN-100PP	
Toyo-ace								
RY16	5R-1994	74-77		A2	AN-111	AN-108NS	AN-100PP	AN-111CPA
RY31	5R-1994	6/80-85		N2	NK-583A	NK-583NS	NK-556PP	NK-583CP
Town Ace								
YRM	3Y-1998	92-		N2	NK-572A	NK-572NS		
TRIUMPH								
1300								
	1297	66-71	CDS150	CD1	CD-200	CD-200NS	CD-200PP	
TC	1297	67-71	HS2	SU1x2	SU-750	SU-750NS		









Notes:

Carburettor Repair Kits & Parts

				Type of carb. No. of barrels No. of carbs				
Make & Model	Eng Size	Year	Carb. Model		Repair Kit	Needle & Seat	Pump Plunger	Choke Pull Off
TRIUMPH (Continued)								
1500	1493	70-74	HS4	SU1	SU-750	SU-750NS		
TC	1493	4/75-76	HS4	SU1x2	SU-750	SU-750NS		
TC	1493	70-3/75	HS2	SU1x2	SU-750	SU-750NS		
1500								
TC	1493	76-77	HS4	SU1x2	SU-768	SU-750NS		
2000	1998	64-74	150 CD,S,3,SE	CD1x2	CD-200	CD-200NS	CD-200PP	
	1998	74-75	HS4	SU1x2	SU-750	SU-750NS		
2000 & 2500								
TC	1998,2498	74-75	HS4	SU1x2	SU-750	SU-750NS		
2000,2500 & 2.5L	1998,2498	76-79	HS6 Capstat	SU1x2	SU-769	SU-750NS		
2000								
TC	1998	75-76	HS6	SU1x2	SU-754	SU-750NS		
Dolomite	1854	71-73	CD3/SEV	CD1x2	CD-200	CD-200NS	CD-200PP	
	1854	74-76	HS4	SU1x2	SU-750	SU-750NS		
	1497	76-80	HS4	SU1x2	SU-760	SU-750NS		
	1296	76-80	HS4	SU1x2	SU-768	SU-750NS		
	1854cc	75-78	150 CD-3,SEV	CD1x2	CD-200	CD-200NS	CD-200PP	
HL	1854	76-80	HS4	SU1x2	SU-768	SU-750NS		
Sprint	2000cc	75-78	HS6	SU1x2	SU-754	SU-750NS		
Sprint	1998	74-76	HS6	SU1x2	SU-754	SU-750NS		
Sprint	1998	76-80	HS6	SU1x2	SU-768	SU-750NS		
GT6								
		69-74	150CD,S,SE,SEV	CD1x2	CD-200	CD-200NS	CD-200PP	
MKII,III	1998	69-74	CDS/SE	CD1x2	CD-200	CD-200NS	CD-200PP	
Herald								
1200	1147	62-67	30 PSEI	SL1	ZE-853	ZE-853NS	ZE-853PP	
1360	1147-1296	67-71	CD150	CD1x2	CD-200	CD-200NS	CD-200PP	
948	948	58-62	28 ZIC	Z1	SX-744A			
948 Coupe	948	58-62	H1	SU1x2	SU-765	SU-750NS		
Spitfire								
MK,II	950,1147	62-66	HS2	SU1x2	SU-750	SU-750NS		
MK,III,IV,V	1296	67-74	HS2	SU1x2	SU-750	SU-750NS		
Stag								
		72-78	175CD-2S,2SEV	CD1x2	CD-201	CD-201NS	CD-200PP	
V8	2997	70-77	CD2S/SEV	CD1x2	CD-205	ZE-864NS	CD-201PP	
Toledo								
	1300	70-75	HS4	SU1	SU-750	SU-750NS		
TS	1439	74-76	HS4	SU1x2	SU-750	SU-750NS		
TR4 & 4A								
with CD Carbs		63-65	175 CD	CD1x2	CD-209	CD-200NS		
TR4A		2138	65-68	HS6	SU1x2	SU-754	SU-750NS	
TR6	2498	70-75	175CD-2SE,IV,X	CD1x2	CD-201	CD-201NS	CD-201PP	
TR7								
	1998	76-81	HS6	SU1x2	SU-750	SU-750NS		
	1998	74-81	HS6	SU1x2	SU-754	SU-750NS		
TR8								
	3525	76-81	CDSET	CD1x2	CD-201	CD-201NS	CD-201PP	
Vitesse								
MK,II 6 Cyl.	1998	66-72	CDSCDSE	CD1x2	CD-200	CD-200NS	CD-200PP	









Notes:

Carburettor Repair Kits & Parts

				Type of carb. No. of barrels				
Make & Model	Eng Size	Year	Carb. Model	No. of carbs	Repair Kit	Needle & Seat	Pump Plunger	Choke Pull Off
VAUXHALL								
Chevette								
1256cc	1256	76-81	150 CDSET	CD1	CD-200	CD-200NS	CD-200PP	
Magnum								
1300	1256	76-77	150 CDS	CD1	CD-200	CD-200NS	CD-200PP	
1800	1800	76-77	175 CDSET	CD1	CD-201	CD-201NS	CD-201PP	
Velox, Cresta								
	2599	61-76	42VNT	Z1	ZE-851	CD-200NS		
Victor								
101,1600	1600	65-67	34IV	Z1	ZE-852	ZE-852NS		
FB	1498	62-64	34IV	Z1	ZE-852	ZE-852NS		
FC 1600 O.H.V	1600	65-67	34IV,34IVD	Z1	ZE-852	ZE-852NS		
FD 1600 O.H.C	1600	68-71	36IV	Z1	ZE-852	ZE-852NS		
FD 2000 O.H.C	2000	71-72	175 CDS	CD1	CD-201	CD-201NS	CD-201PP	
FD 2000 O.H.C	2000	67-70	36IV	Z1	ZE-852	ZE-852NS		
FE,Magnum 2300	2300	72-77	175 CDSET	CD1	CD-201	CD-201NS	CD-201PP	
Viva								
1800 O.H.C	1800	75-77	175 CDSET	CD1	CD-201	CD-201NS	CD-201PP	
HA	1256	64-67	CD150	CD1	CD-200	CD-200NS	CD-200PP	
HA	1256	64-67	30 PSEI	SL1	ZE-853	ZE-853NS	ZE-853PP	
HA, HB	1256	64-67	30IZ,30PSEI	Z1	ZE-853	ZE-853NS	ZE-853PP	
HB,HC	1256	67-77	150 CDS	CD1	CD-200	CD-200NS	CD-200PP	
HB,HC	1256	67-75	30IZ	Z1	ZE-853	ZE-853NS	ZE-853PP	
Wyvern								
	2200	49-50	30VIG	Z1	ZE-863	CD-200NS		
VOLKSWAGEN								
TYPE III -								
Sedan, Wagon, Fastback								
1500								
Sedan, Wagon	1493	63-67	32PHN	SL1	SX-707	SX-703NS	SX-703PP	
1500, 1600								
Twin carb.	1493	63-67	32PDSIT	SL2x2	SX-705	SX-701NS	SX-705PP	
1600								
Sedan, Wagon, Fastback	1584	66-74	32PDSIT	SL2	SX-705	SX-701NS	SX-705PP	
TYPE I - Beetle								
1600 (Alternator)	1584	76	34PCIT4	SL1	SX-738			
36HP	1192	54-61	28PCI	SL1	SX-746			
40hp, 1200, 1300, 1500	1192-1493	62-70	28-31PICT	SL1	SX-703	SX-703NS	SX-703PP	SX-703CP
L-Bug, S'bug	1584	71-75	34PICT3	SL1	SX-703	SX-703NS	SX-703PP	SX-703CP
Golf								
Passat								
GLS LS	1588	76-80	34PICT5	SL1	SX-704		SX-704PP	
L,LS,GLS	1598	76-80	34PICT5	SL1	SX-712A	SX-710NS	SX-705PP	
TS	1471	74-75	32/35TDID	SL2	SX-7099	SX-710NS	SX-705PP	
VOLKSWAGEN COMMERCIAL								
Kombi								
1700,1800,2L	16-19	73-81	34PDSIT	SL1x2	SX-701	SX-701NS	SX-701PP	SX-701CP
40hp 1200,1500,1600	1192-1598	60-75	34PICT	SL1	SX-703	SX-703NS	SX-703PP	SX-703CP
TYPE II - KOMBI								
Vanagon (with American Reg)	2.0L	80-81	34PICT	SL1x2	SX-701	SX-701NS	SX-701PP	

Notes:

Carburettor Repair Kits & Parts

				Type of carb. No. of barrels No. of carbs				
Make & Model	Eng Size	Year	Carb. Model		Repair Kit	Needle & Seat	Pump Plunger	Choke Pull Off
VOLVO								
122S	B18A-1780	65-66	HS6	SU1x2	SU-754	SU-750NS		
140	B18-1788	67-68	CD175	CD1x2	CD-201	CD-200NS	CD-201PP	
	B20A-1990	68-74	CDSE175	CD1	CD-201	CD-200NS	CD-201PP	
	B20B-1990	68-74	CDSE175	CD1x2	CD-201	CD-200NS	CD-201PP	
140	B18-1788	67-68	HS6	SU1x2	SU-754	SU-750NS		
	B20B-1990	68-70	HS6	SU1x2	SU-754	SU-750NS		
	B20A-1990	69-70	HS6	SU1	SU-754	SU-750NS		
	B20B-1990	71-74	HIF6	SU1x2	SU-760	SU-750NS		
	B20A-1990	74	HIF6	SU1	SU-760	SU-750NS		
	B30A-2978	68-75	CDSE175	CD1x2	CD-201	CD-201NS	CD-201PP	
1800	B18-1788	63-68	HS6	SU1x2	SU-754	SU-750NS		
	B18B-1788	63-68	HS6	SU1	SU-754	SU-750NS		
240	B20A-1990	74-77	CDSE175	CD1	CD-201	CD-201NS	CD-201PP	
	B23A-2316	7/80-84	CDUS175	CD1	CD-207		CD-201PP	
	B21A	1/83	CDMS	CD1	CD-208	CD-200NS	CD-201PP	
	B20A-1990	74-80	HIF6	SU1	SU-760	SU-750NS		
	B21A-2127	75-77	HIF6	SU1x2	SU-760	SU-750NS		
	English	B21A-2127	75-80	CDSE175	CD1	CD-201	CD-201NS	CD-201PP
German	B21A-2127	7/77-84	CDUS175	CD1	CD-207		CD-201PP	
240,244								
DL	B20A-1990	75-80	CDSE175	CD1	CD-205		CD-201PP	
244								
DL	B21A-2127	3/81	CD175	CD1	CD-208	CD-200NS	CD-201PP	
264/265								
	B27A-2664	75-79	HIF6x2	SU1x2	SU-760	SU-750NS		
340								
	B14-1397	76-84	32SEIA	SL1	SX-723			
360								
	B19A-1986	82-84	CDUS175	CD1	CD-207		CD-201PP	
760								
	B28A-2849	81-84	HIF6	SU1x2	SU-760	SU-750NS		

Notes:

Repair Kit Identification

Illustrations - By Main Identifying Components

AISAN

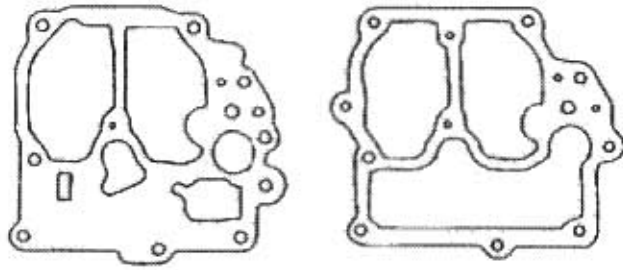

AN-100A

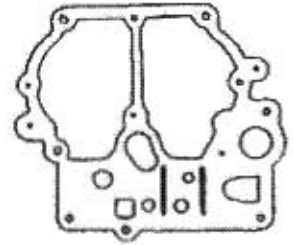

This gasket supersedes all previous versions.

AN-103B

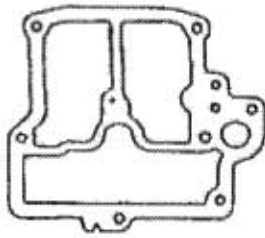

AN-101



AN-106A

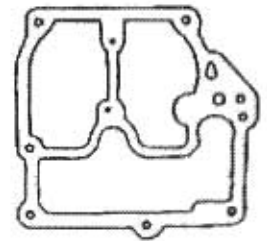
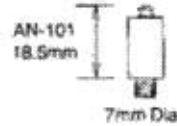

AN-108

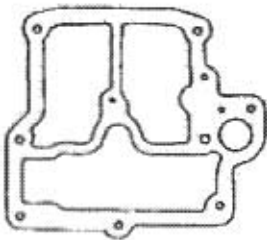

AN-107NZ

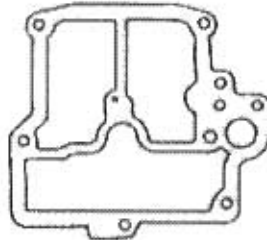

DW2B
AN-129 (Turbo)

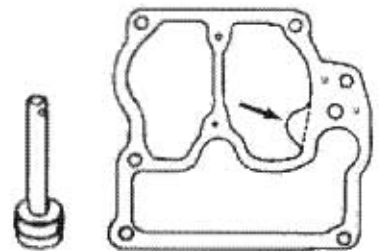
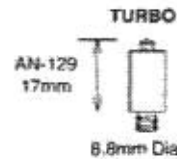
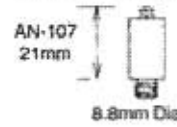

AN-110

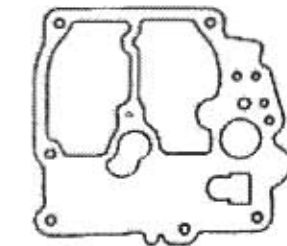
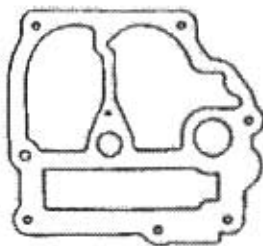

AN-111

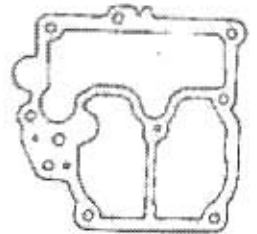

AN-126

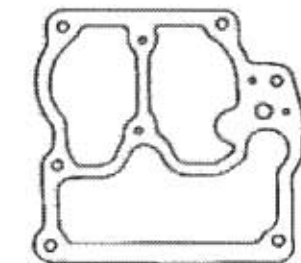
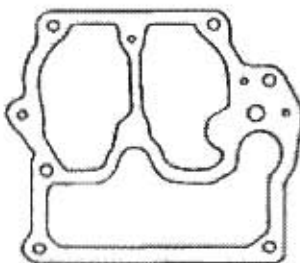

AN-113A

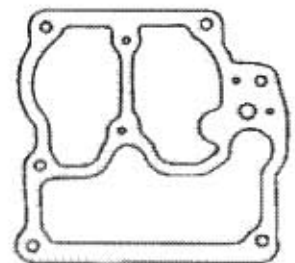

AN-114

Repair Kit Identification

Illustrations - By Main Identifying Components

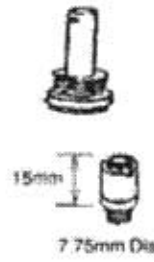
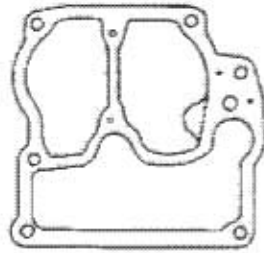
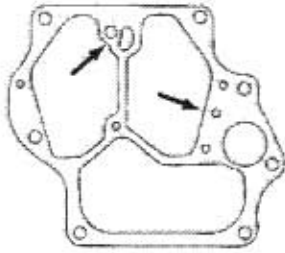

AN-109A

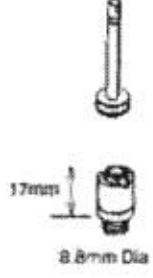
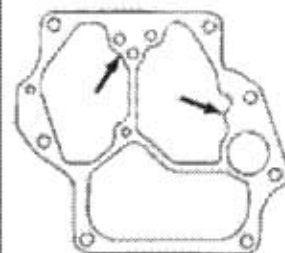

AN-102

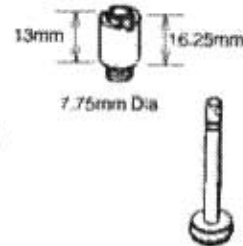
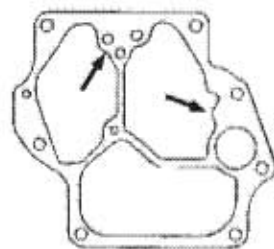
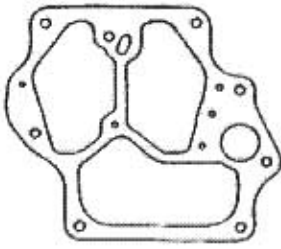

2 x needles in kit
AN-116A

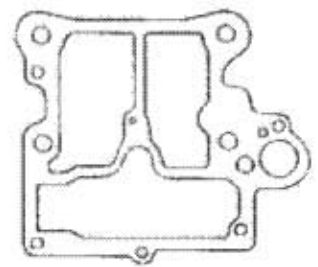

AN-124NZ

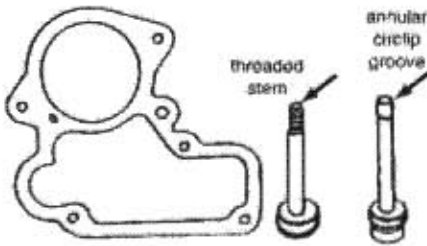

AN-118A

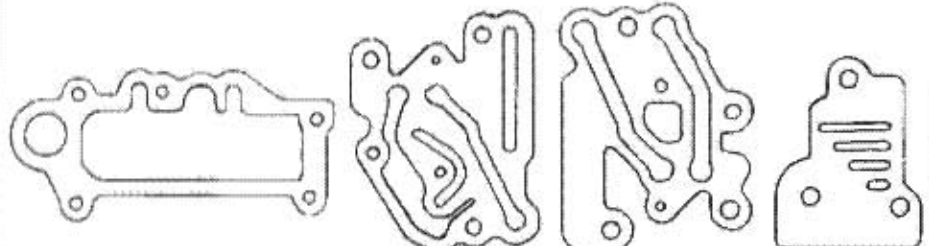

AN-128

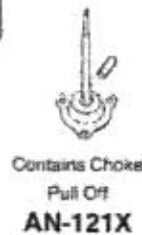
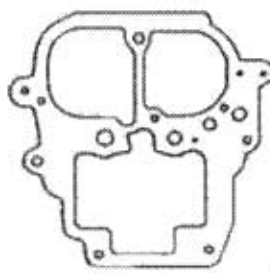
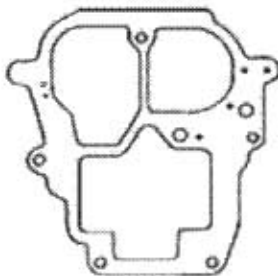

AN-121A

Contains Choke
Pull Off
AN-121X

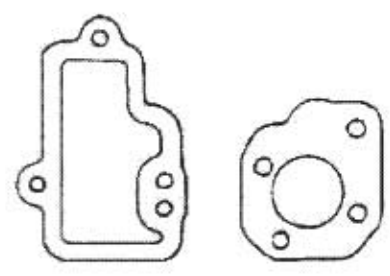

AN-123

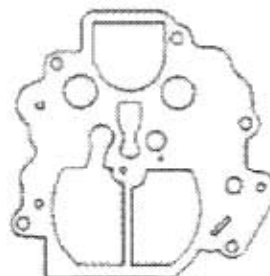
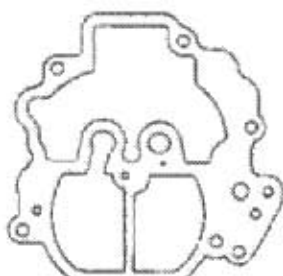

AN-127

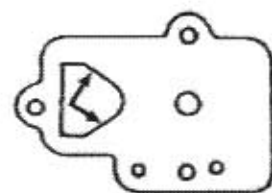

AN-122

Repair Kit Identification

Illustrations - By Main Identifying Components

CARTER

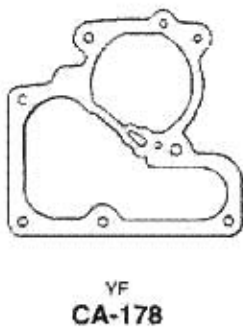
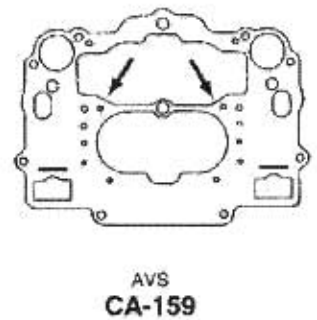
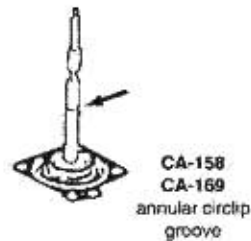
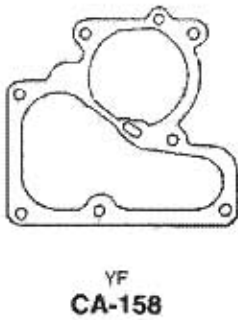
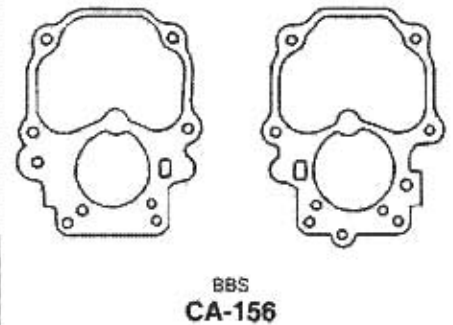
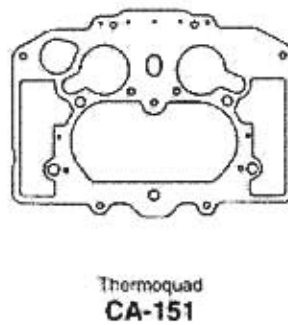
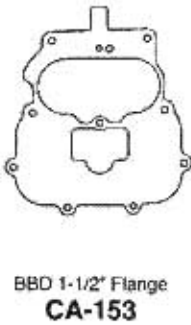
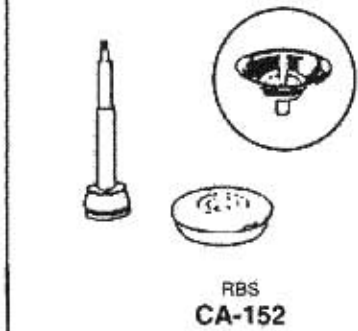
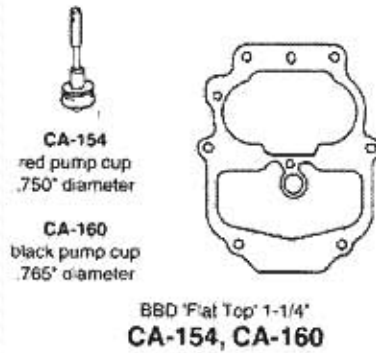
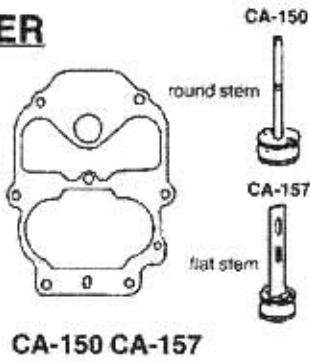

CA-158
circclip groove on diaphragm
stem - viton tip spring loaded
needle valve

CA-169
AMC Jeep
annular groove on diaphragm
stem - viton tip solid needle
valve

CA-175
AMC Jeep

CA-178
AMC Jeep

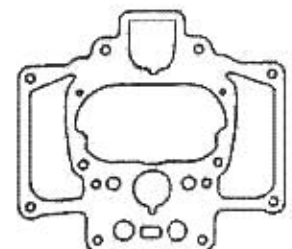
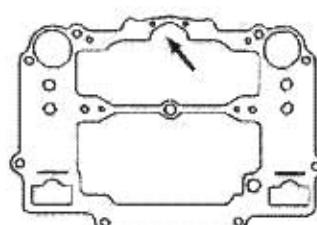
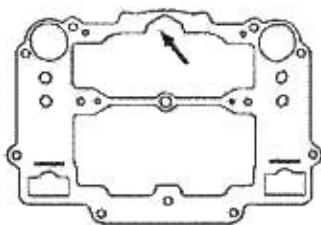
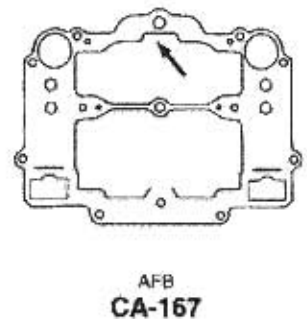

Repair Kit Identification

Illustrations - By Main Identifying Components

CARTER (continued)

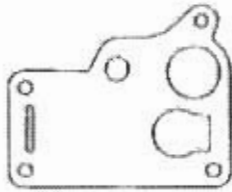

WO
CA-164

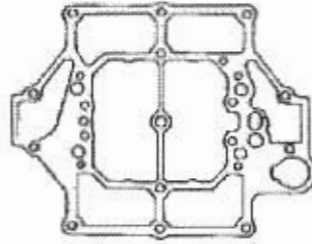

WCFB
CA-163

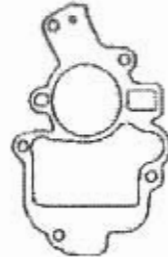
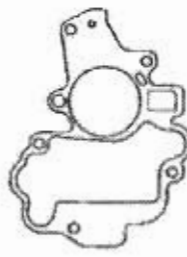
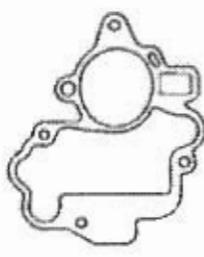
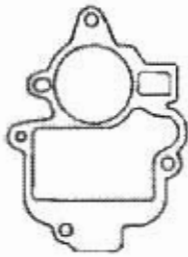
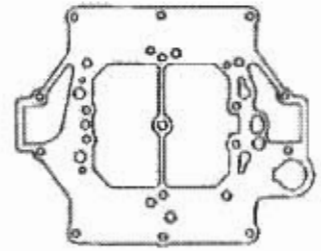

B&B
CA-165

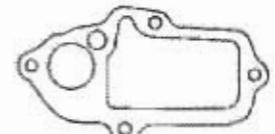
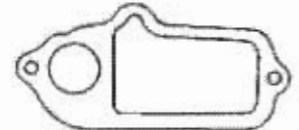

W-1
CA-168

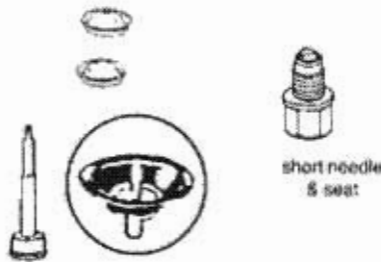

RBS, AMC Jeep only
CA-177

ZENITH - STROMBERG



CD-175 fitted with diaphragm using horizontal location tabs. use CD-201PP with tabs cut off. Ensure piston alignment is correct

This diaphragm is used in,
CD-202 CD175
CD-203 CDS/CDT/CDTV175
CD-204 CD175
CD-205 CDSE175, (Turbo)
CD-206 CDE175
CD-207 CDVS175
CD-208 CD175



125 / 150 CD
CD-200

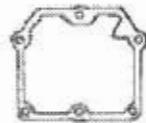

CD175
CD-201

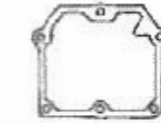

Rover 175CDEF
CD-206

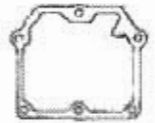

CD175
CD-209

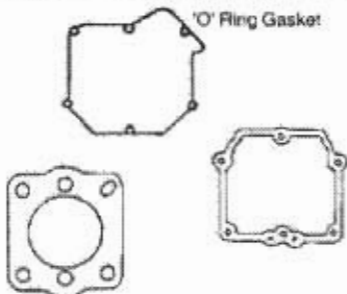

CDVS175
CD-207



175CDE1
Economy diaphragm BMW

CD175
CD-202



Choke Pull-Off diaphragm
Mercedes Benz

CDS, CDT, CDTV175
CD-203

Repair Kit Identification

Illustrations - By Main Identifying Components

ZENITH-STROMBERG



2.5mm Synthetic seat for use
with turbocharges

CD175
CD-204



By pass valve assembly
Jaguar B18680Z replaces
B18696Z

CDSE175
CD-205



CDS175
CD-208

DELLORTO

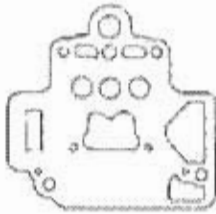

40-DHLA
DE-250

FORD / MOTORCRAFT

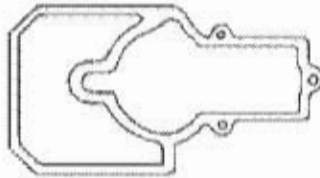

"W"
FD-307

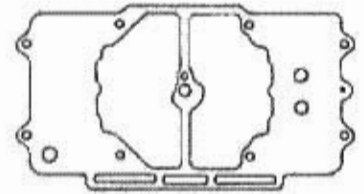

4100
FD-302

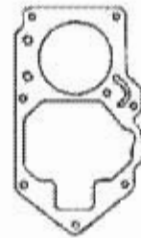
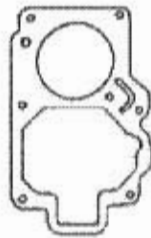
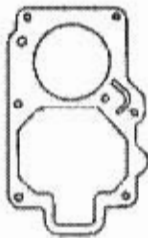

"1250"
FD-300

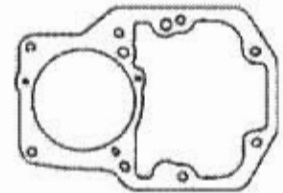

1100
FD-303

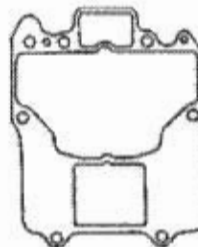
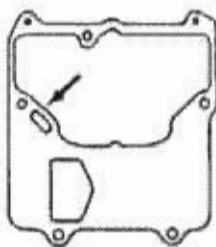

2100-2150
FD-306A

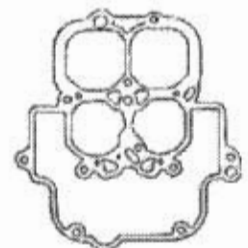

4300
FD-304

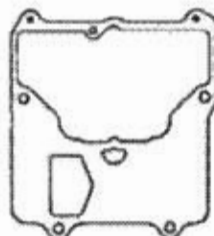
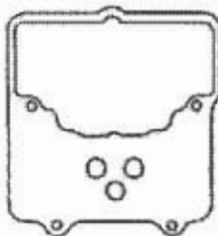

2100
FD-301

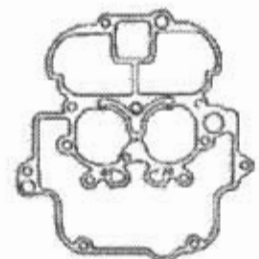

4350
FD-305

Repair Kit Identification

Illustrations - By Main Identifying Components

HITACHI

A

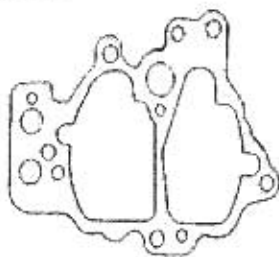

A1

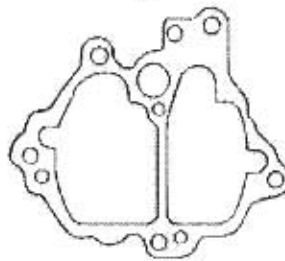

C

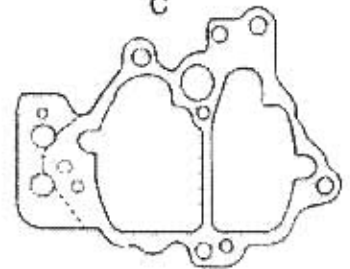

HT-400

NOTE: All gaskets marked B now supersede in kits gaskets marked A & A1

A

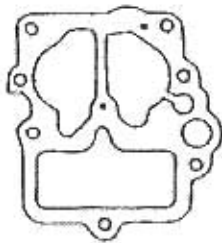

B



Intermediate gasket

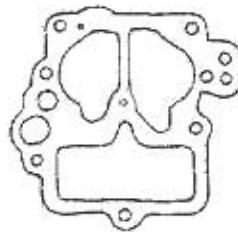

HT-401

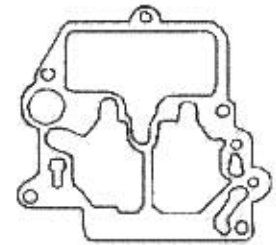

HT-431

A

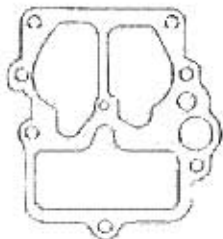

B



Intermediate gasket

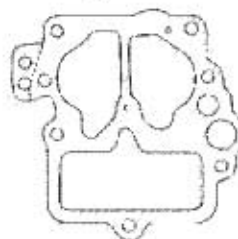

HT-412

Base gasket

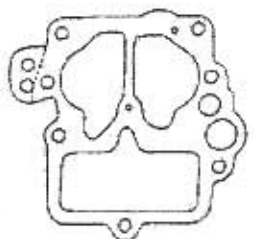

HT-428

A

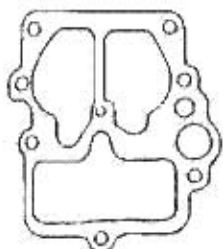

A1



Intermediate gasket

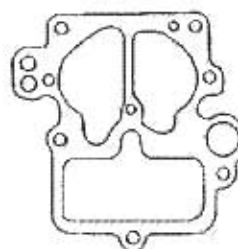

HT-413

B

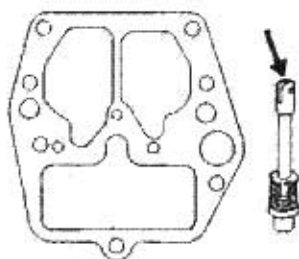
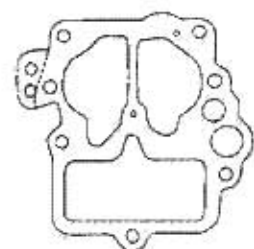

HT-420

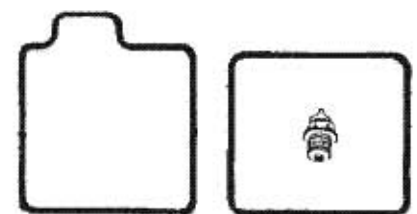
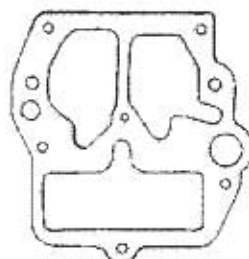

HT-414

Repair Kit Identification

Illustrations - By Main Identifying Components

HITACHI (Continued)

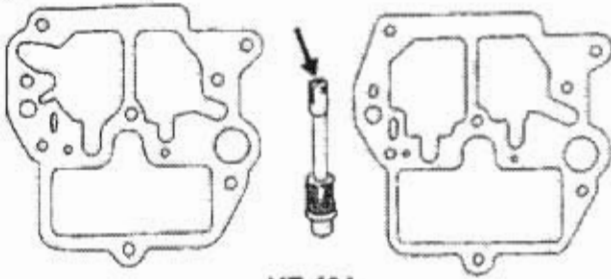

HT-424

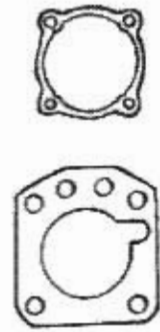

HT-405

A=21.8mm

HT-406

A=24.4mm

HT-407

A=21.3mm

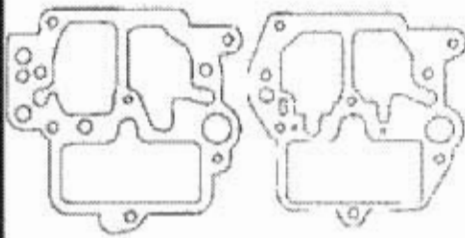

HT-425

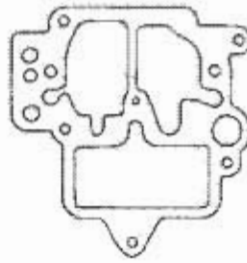

HT-430

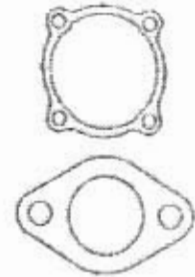

HT-416

HT-417

major kit

HT-416X includes main jets & needles

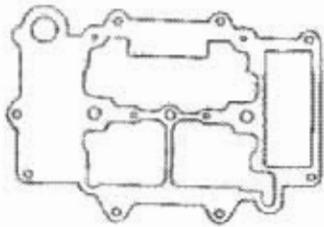

HT-415

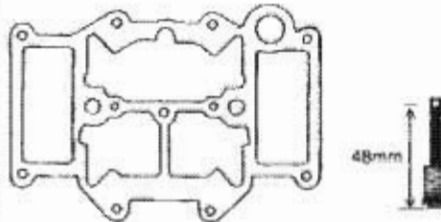

HT-418

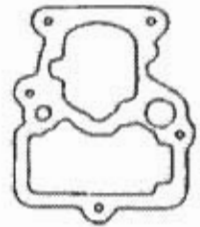

HT-411



HT-410



HT-409

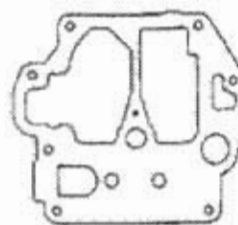

HT-427

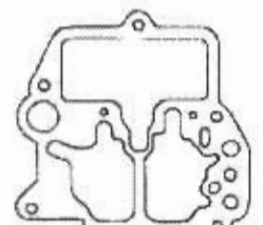

HT-429

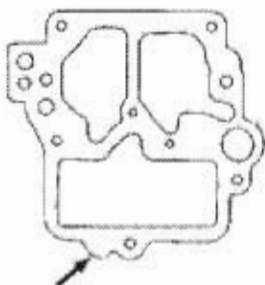

HT-421A

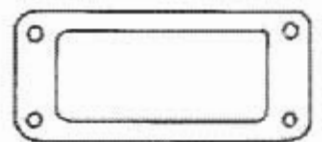
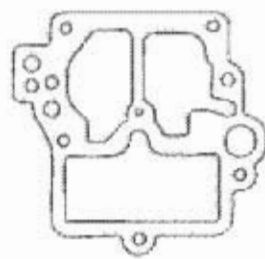
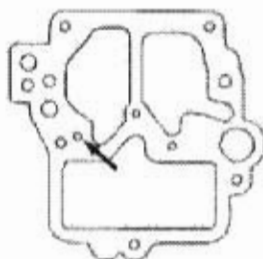

HT-419

Repair Kit Identification

Holley Base Gasket Identification

HOLLEY

Kits:
HY-352
HY-353
HY-359
HY-365
HY-365X

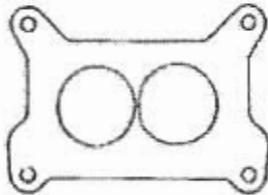

MODELS:
2300, 2305

Kits:
HY-350
HY-357
HY-361
HY-381
HY-381X
HY-384
HY-391
HY-392

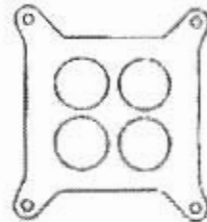

'SQUAREBORE' MODELS:
4150, 4160

Kits
HY-363
HY-368
HY-369

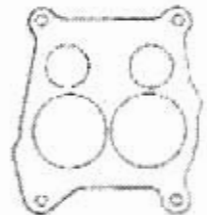

'SPREADBORE' MODELS:
4165, 4175

Holley Two Barrel Carburetors

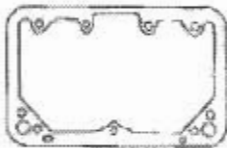

HY-36

Model 2300, Internal non adjustable needle & seat
HY-352

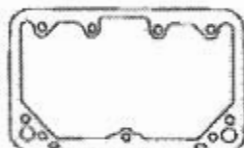

HY-350NS

Model 2300, 2305, Externally adjustable N/Seat
HY-353

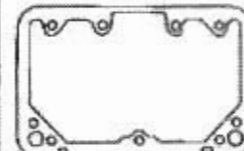

HY-350NS

Model 2300G, International & Ford trucks with governor
HY-365

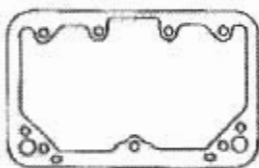

HY-350NS

Model 2300G, 2300EG. Contains HY-365 plus governor diaphragm and insulating flange gasket
HY-365X

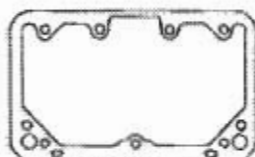

HY-350NS

500cfm carburetors, R4412, R80095, 2300, 2305
HY-359

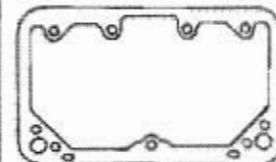

HY-350NS

Jensen Interceptor Model 2300 x 3
HY-390

Holley 4 Barrel 'Squarebore' Carburetors



HY-363NS

4160 Vacuum Secondary
HY-391

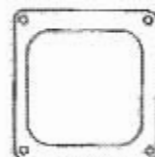
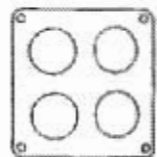

1050cfm, 1150cfm 'Dominator'
Includes .130" Needle & Seats
HY-370

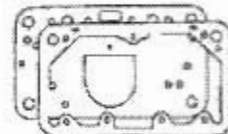

HY-350NS

Vacuum Secondary 4150
HY-357

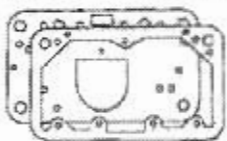

HY-350NS

International & Ford Trucks
fitted with governor
Vacuum, 4150 series
HY-381

Expanded kit containing HY-381 plus governor diaphragm, vacuum secondary diaphragm, heat insulator flange gasket
HY-381X

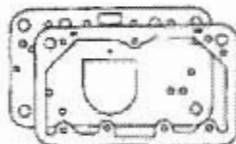

HY-359PP



Double-Pump 4150, list R9645, R9646
HY-361
Expanded kit with .130" Steel-tipped N/S
HY-361X



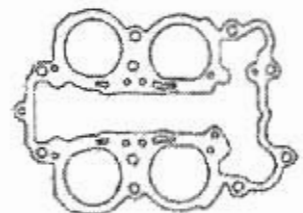







SPREADBORE FLANGE

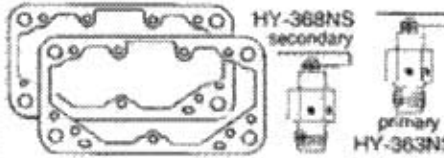

Model 4360
HY-362

Repair Kit Identification

Holley 'Spreadbore' Carburettors

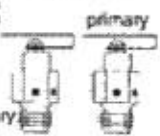
<p>HOLLEY</p>  <p>HY-350PP HY-359PP</p>  <p>HY-350NS</p> <p>Model 4150, Spreadbore Double Pump List nos. R6708, 6709</p> <p>HY-392</p>	 <p>HY-350PP HY-359PP</p>  <p>HY-368NS secondary HY-363NS primary</p> <p>Model 4165, Spreadbore Double Pump. Non adjustable Needle & Seat:</p> <p>HY-368</p>	 <p>HY-350PP HY-359PP</p>  <p>HY-350NS</p> <p>Model 4165, Spreadbore Double Pump 650 & 800c.c.m. Adjustable Needle & Seat</p> <p>HY-369</p>
 <p>HY-350PP</p>  <p>HY-350NS</p> <p>Model 4160, S' bore Vacuum Secondary</p> <p>HY-350</p>	<p>HY-359PP</p>  <p>HY-350PP</p>  <p>HY-350NS</p> <p>Model 4160 Spreadbore 'Centre Shooter' List no. R4224</p> <p>HY-384</p>	 <p>HY-350PP</p>  <p>HY-368NS secondary HY-363NS primary</p> <p>Model 4175 S'Bore Vacuum Secondary</p> <p>HY-363</p>

Holley Single & Two Barrel Carburettors

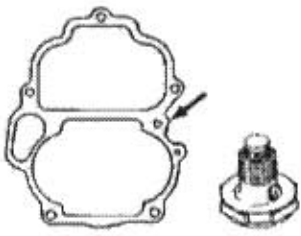
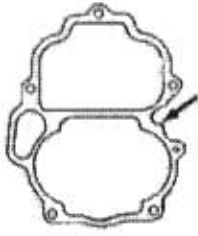
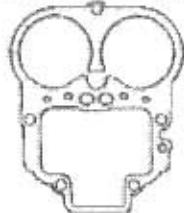
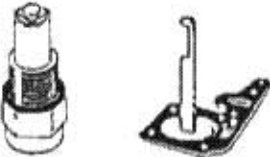
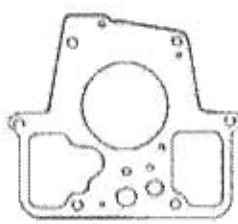
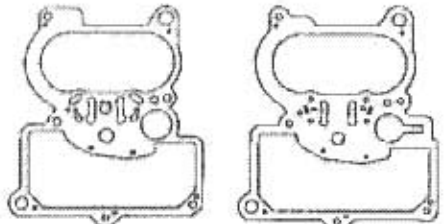
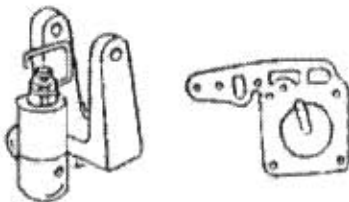
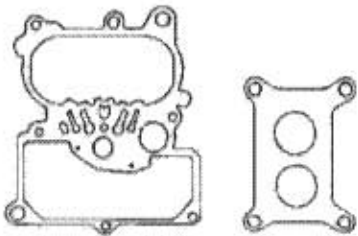
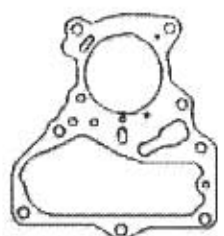
 <p>HY-351</p>	 <p>HY-367</p>	 <p>Model 2300G, Suits International & Ford Trucks with governor.</p> <p>HY-358, HY-358X</p>
<p>Chrysler AP5, AP6</p>  <p>HY-354 (List no. R2535) HY-373 (List no. R2887, R2888)</p>	 <p>HY-364</p>	 <p>HY-383</p>
 <p>HY-355</p>	 <p>HY-360</p>	 <p>HY-372</p>

Repair Kit Identification

Illustrations - By Main Identifying Components

HOLLEY

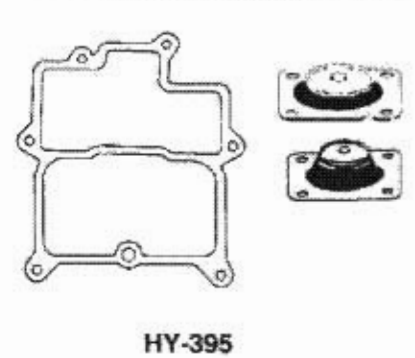
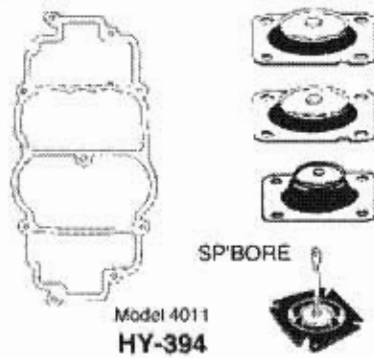
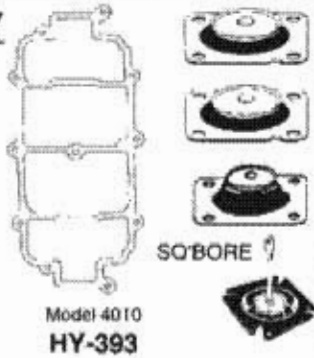

INDUSTRIAL KITS

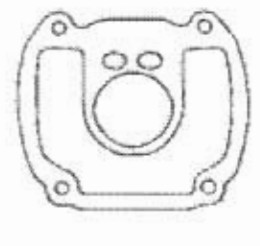
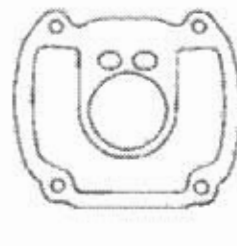
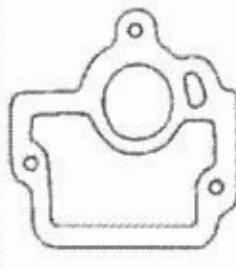
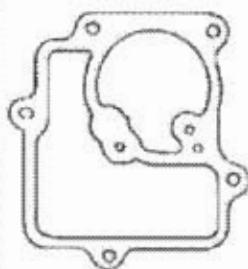
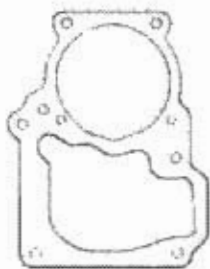
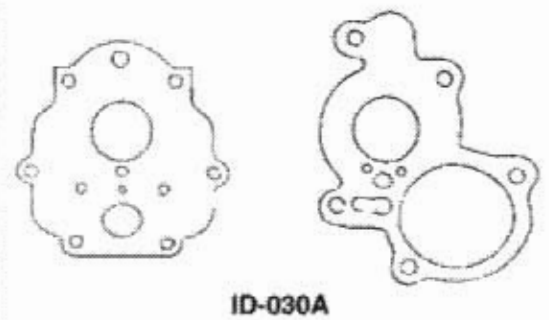
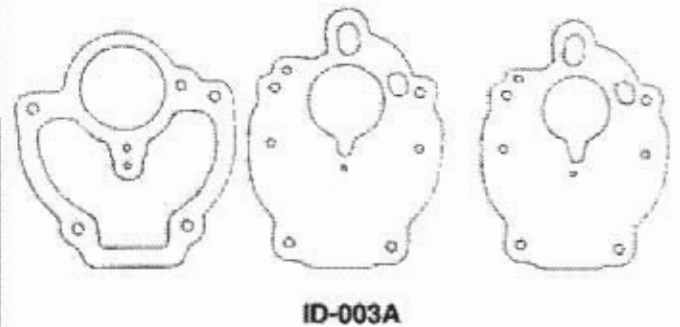
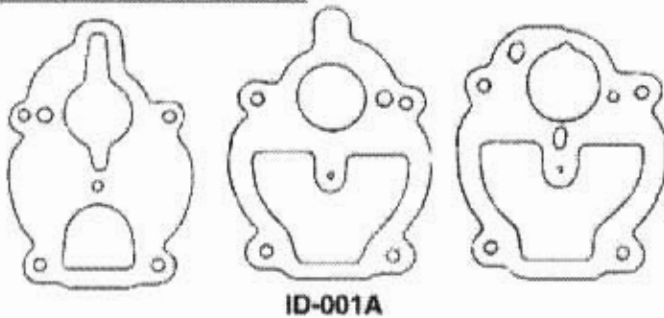

KEIHIN

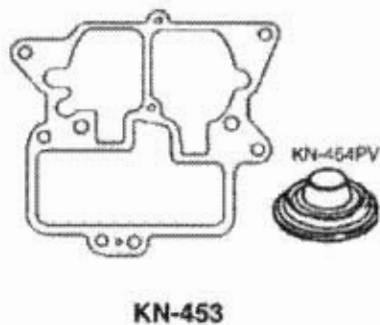
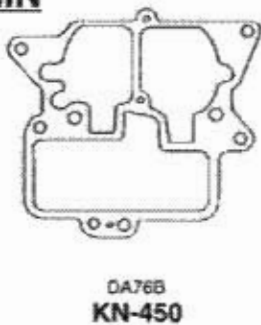

Repair Kit Identification

Illustrations - By Main Identifying Components

KEIHIN (continued)

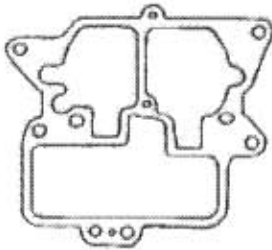

KN-452A

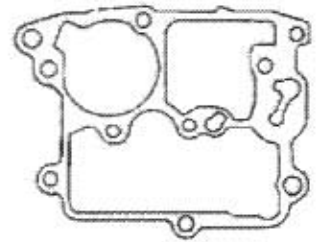
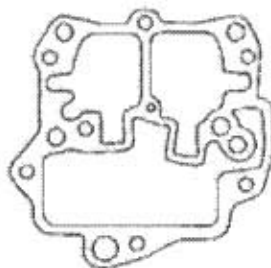
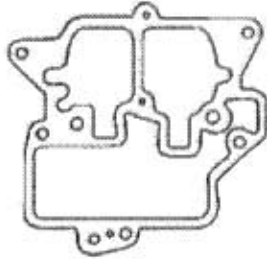

KN-457

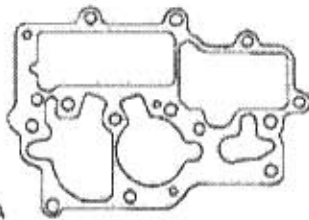
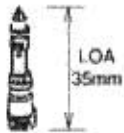

CA02D, 03E, CVCC 3-Barrel
KN-455

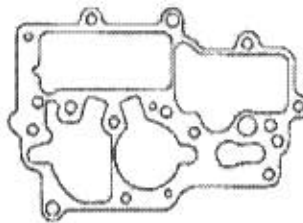

KN-456

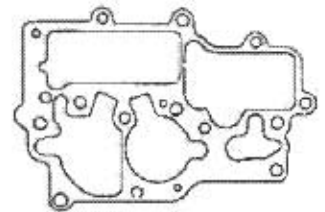
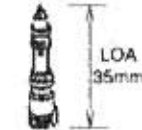

CA06A,B,G CA08C,D, CA12A, CA13A,
CA15A,B, CA16A,B, CVCC 3-Barrel

MIKUNI SOLEX

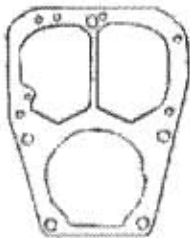

A

MS-500B 32/36 DIDTA

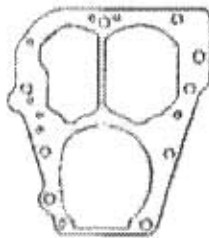

A

MS-500BX Contains Choke Pull-Off

B

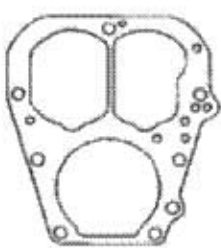

A

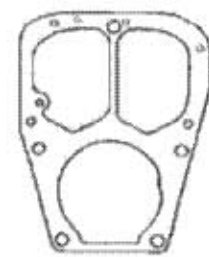

DIDTA
MS-502

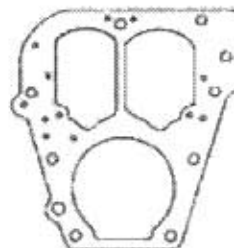

B



O Ring body

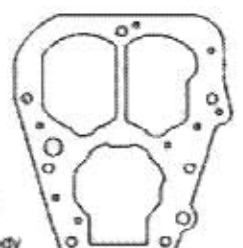

MS-504

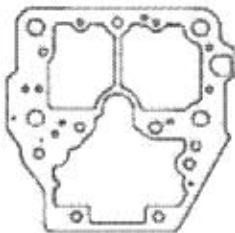

MS-511

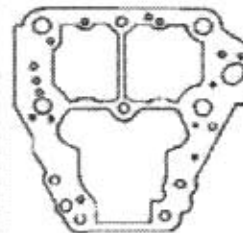
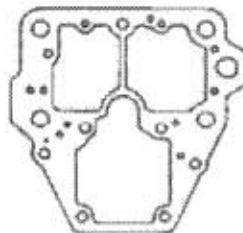

A

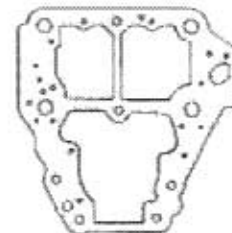

MS-505NZ

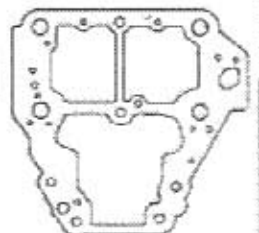

B

Repair Kit Identification

Illustrations - By Main Identifying Components

MIKUNI SOLEX (continued)

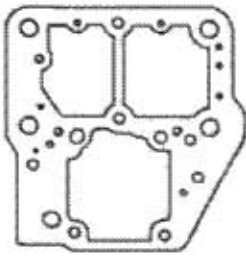

MS-513

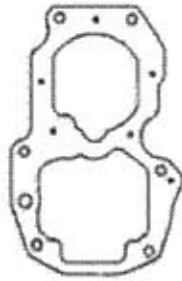

MS-514

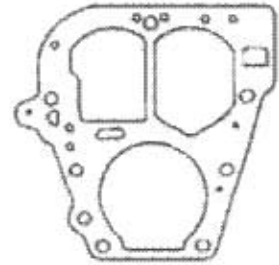

MS-512

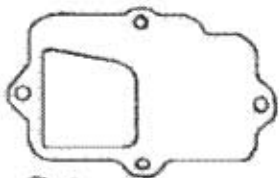

MS-501



O Ring seat

MS-506

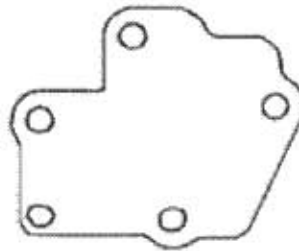

MS-507

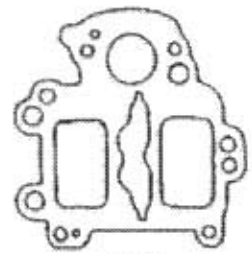

44PHH
MS-508

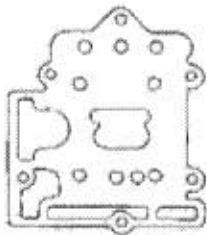

44PHH
MS-509

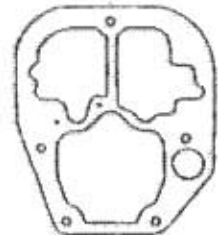
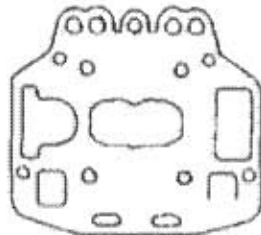

DIDTA
MS-515

NIKKI

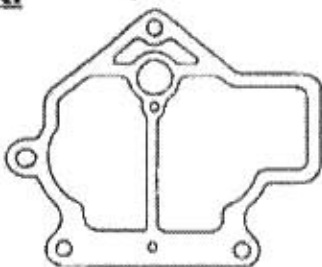

NK-576

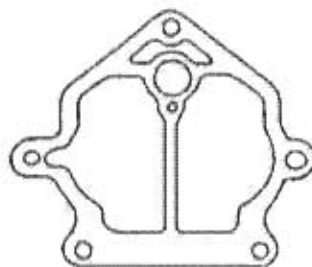

NK-550

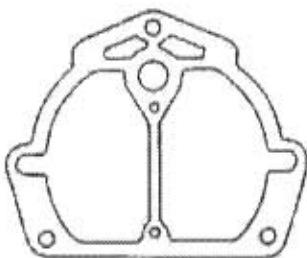
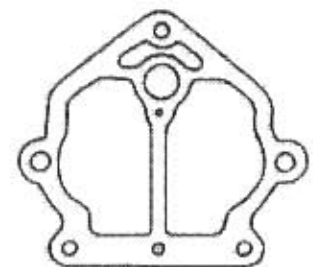

NK-556

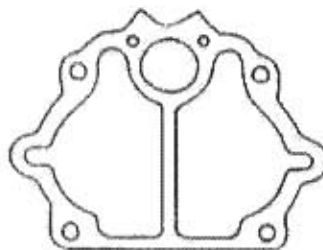

NK-558

Thread
length
22.5mm

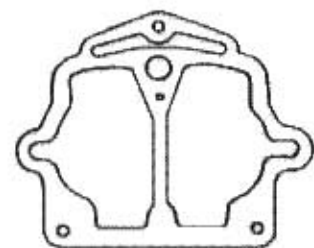

NK-562



Repair Kit Identification

Illustrations - By Main Identifying Components

NIKKI (continued)

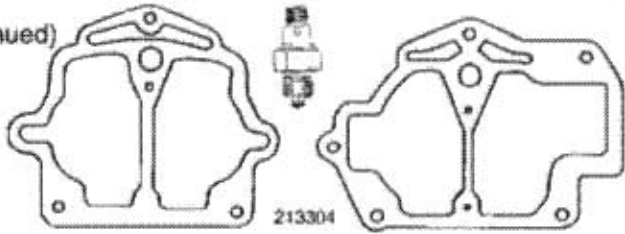

NK-563A

NK-563AX Contains Choke Pull-Off

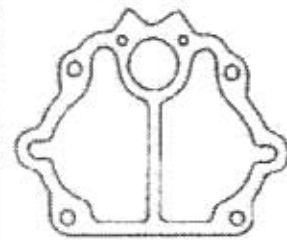

Thread length 22.5mm



NK-559

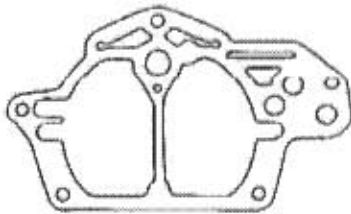

NK-580

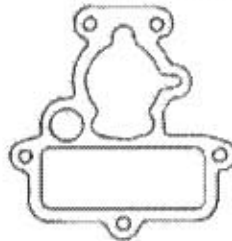

NK-552

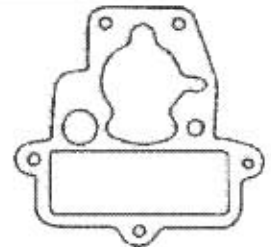

NK-553

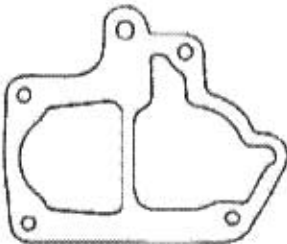

NK-554

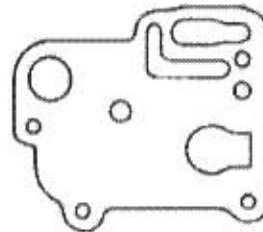

NK-555

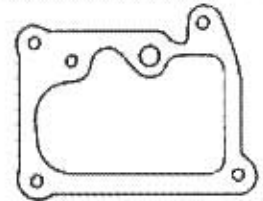

NK-557

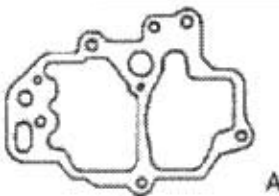
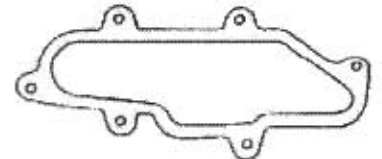
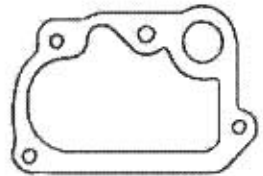

A

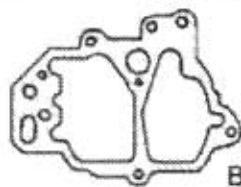

B

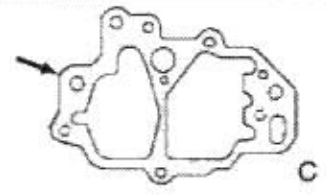

C

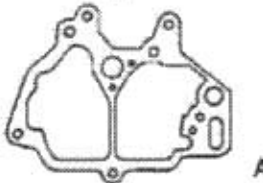

A

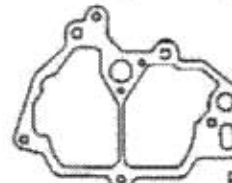

B

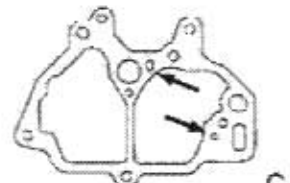

C

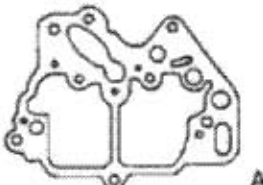

A

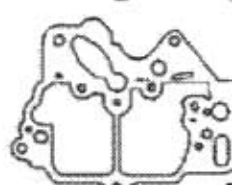

B

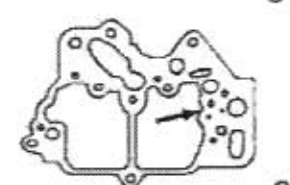

C

NK-566B The bowl gasket shown in drawing 'C' supersedes both similar units shown in 'A' and 'B'.

Repair Kit Identification

Illustrations - By Main Identifying Components

NIKKI (continued)

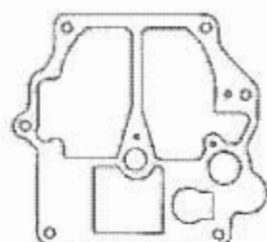
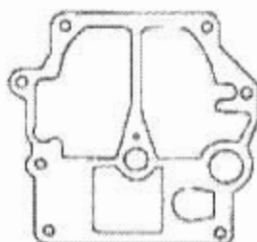
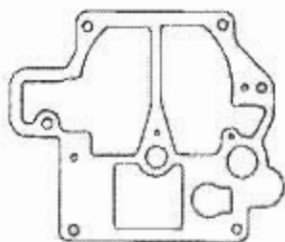

NK-572A

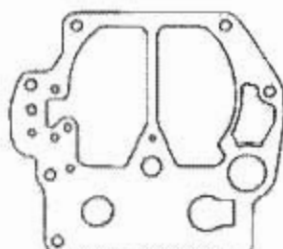
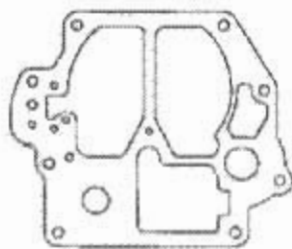
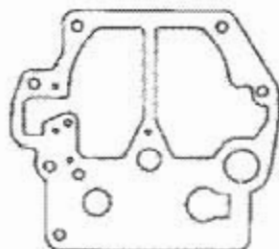

NK-575A

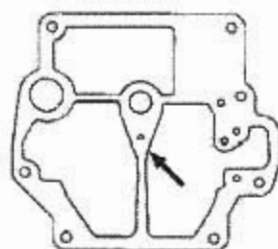

NK-585

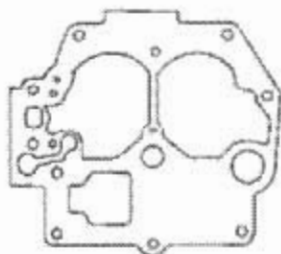

NK-574

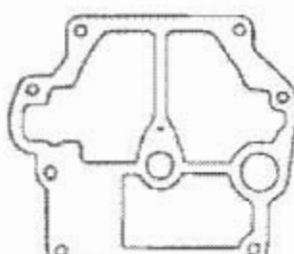

NK-568A

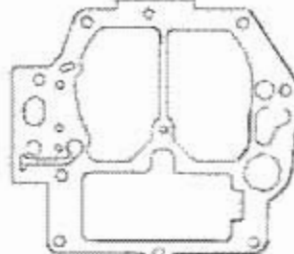

NK-577

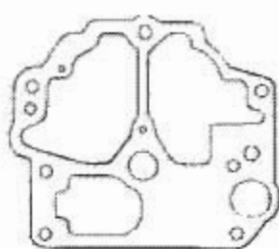
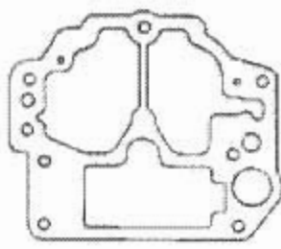
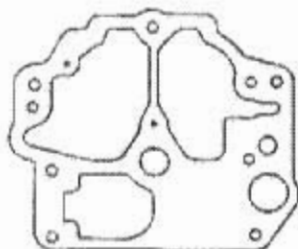

NK-569B



NK-579

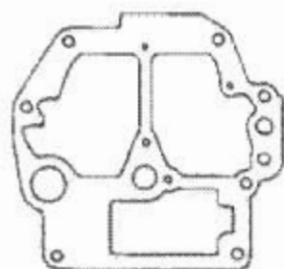

NK-583

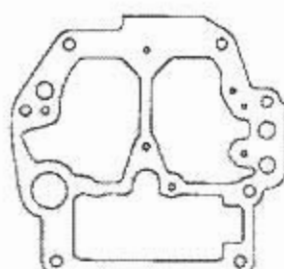

NK-584

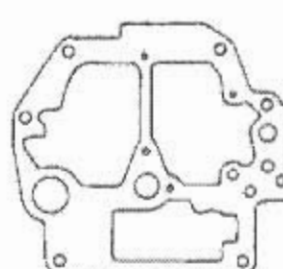

Repair Kit Identification

Illustrations - By Main Identifying Components

NIKKI (continued)

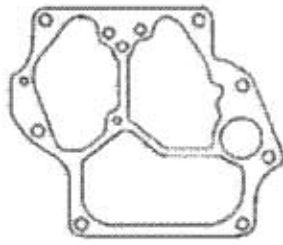
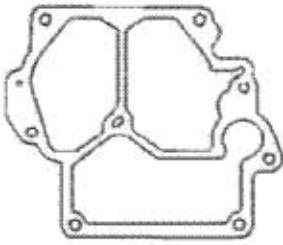

NK-551

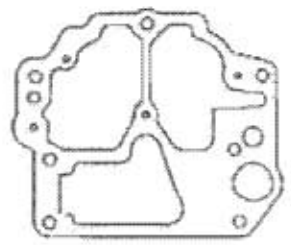

NK-573

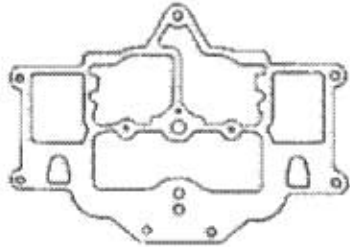
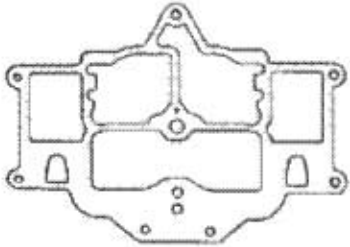

210284
NK-567

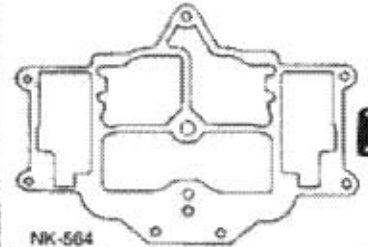

NK-564
Needle valve
Thread dia.
7.84mm

NK-564
Needle valve
Thread dia.
6.84

NK-564, NK-571

ROCHESTER

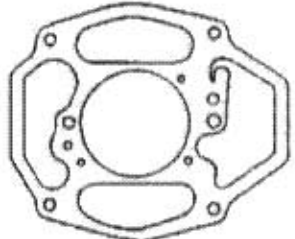
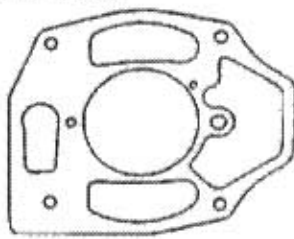

B,BC,BV
RT-600

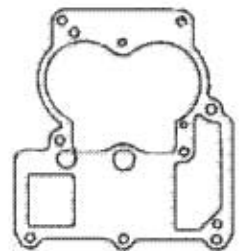

2GC
RT-605

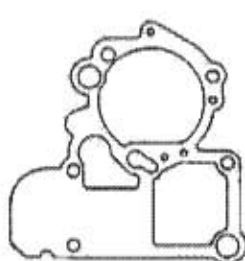
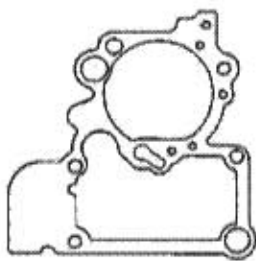

MV
RT-608

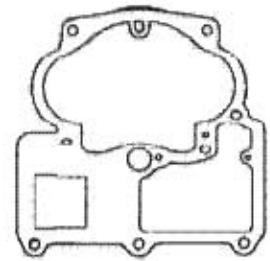

2GV
RT-611

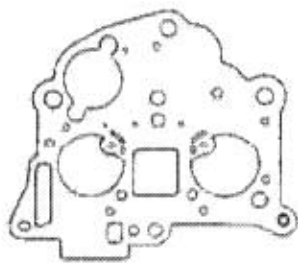
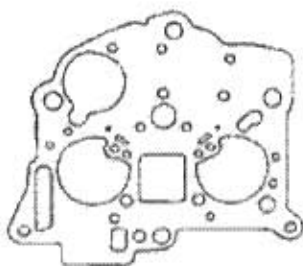

E2ME, M2ME, E2MC, M2MC
RT-622

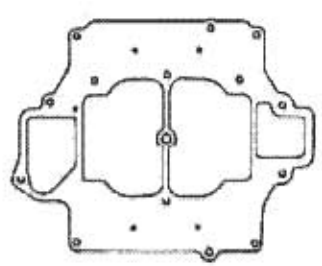

4GC
RT-612

Repair Kit Identification

Illustrations - By Main Identifying Components

ROCHESTER (continued)

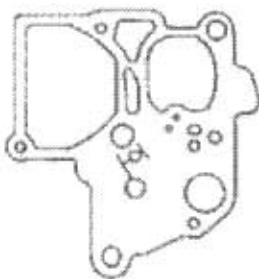
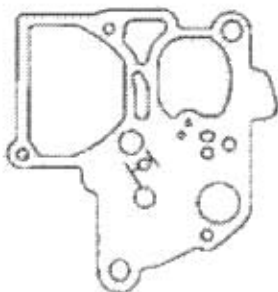

Varajet
RT-604A

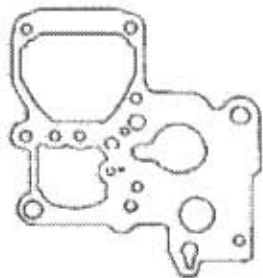
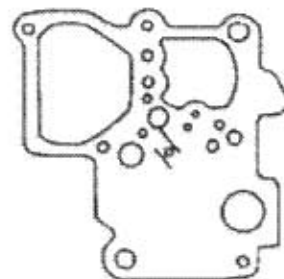

E25E
RT-610

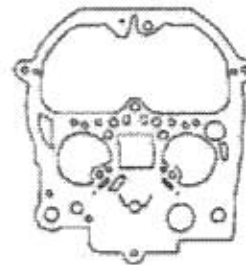
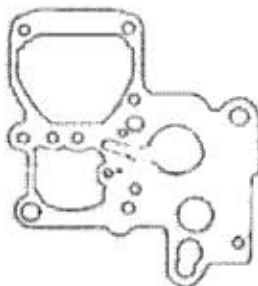

This needle & seat replaces dia type.



push in N/Seat

4MV
RT-613

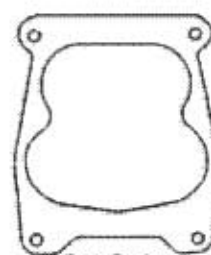
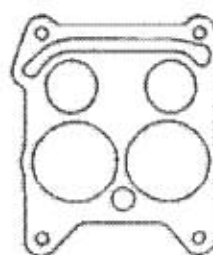
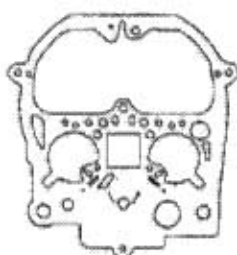
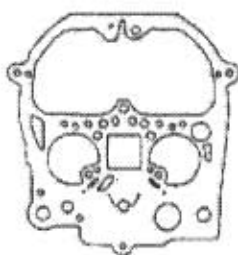
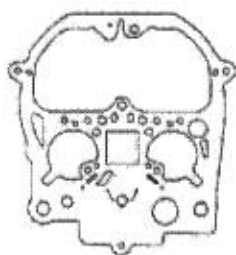

4MV
RT-606A

Base Gasket

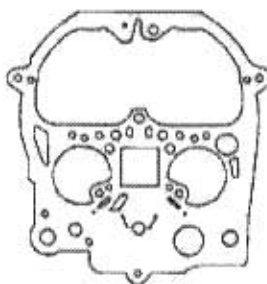

RT-601

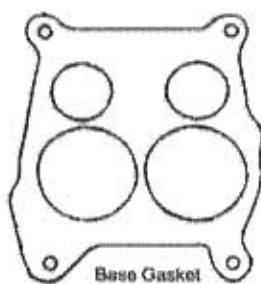

Base Gasket

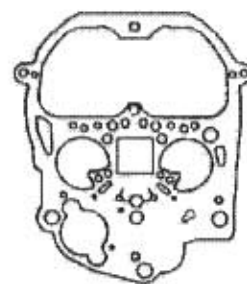

RT-603

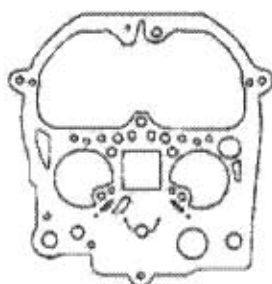

RT-602

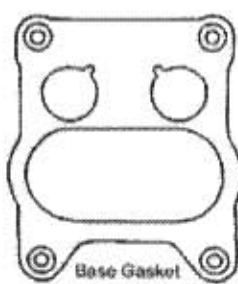

Base Gasket

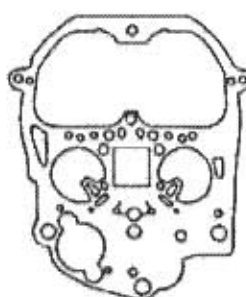

RT-609A

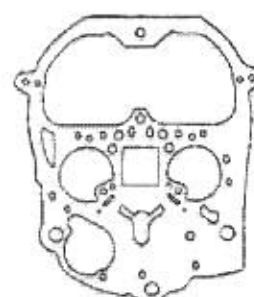

Repair Kit Identification

Illustrations - By Main Identifying Components

STROMBERG

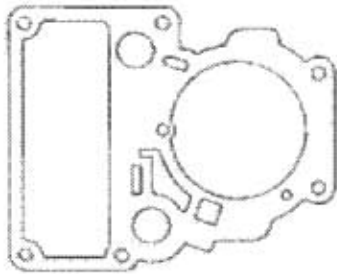

- SB-652 BXUV2, 3BXV, BXOV, BXUV
- SB-653 BXUV-3
- SB-654 BXOV2
- SB-655
- SB-658 BXUV3
- SB-659 BXUV3

Pump Plunger Special Fitting Instructions

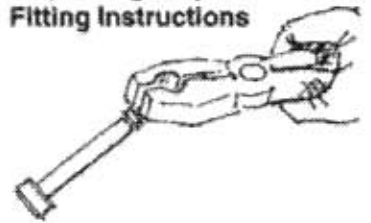

For Pre-emission carburetors with atmosphere vented bowl. Tube fitting, break off tip as shown above

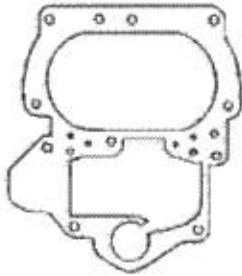

SB-651

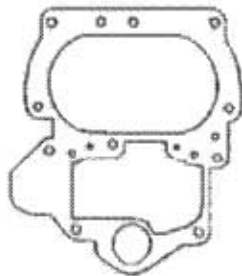

SB-660

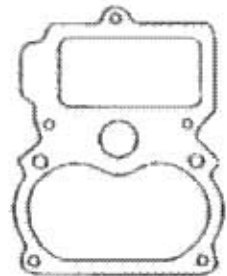

97
SB-663

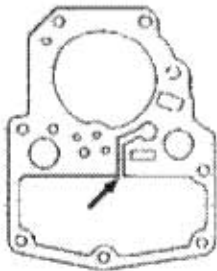

SB-657

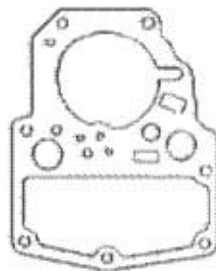

SB-655

For Emission carburetors with cannister vent tube fitting, leave plastic end tip in place

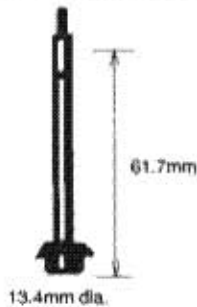

SB-652 Pump Plunger modification

For Pre - emission carburetors with atmosphere vented bowl tube fitting, break of tip at groove, as shown above.



For Emission carburetors with cannister vent tube fitting, leave plastic end tip in place

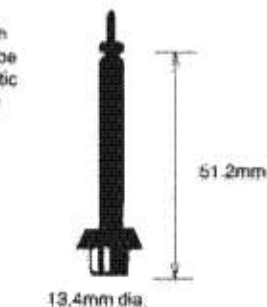

SB-655 Pump Plunger modification

For Pre - emission carburetors with atmosphere vented bowl tube fitting, break of tip at groove, as shown above.

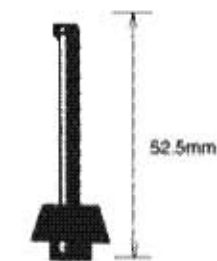

SB-653

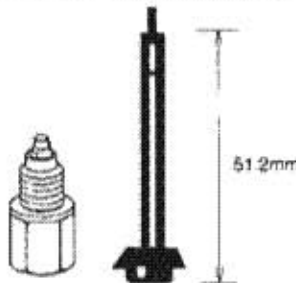

SB-654

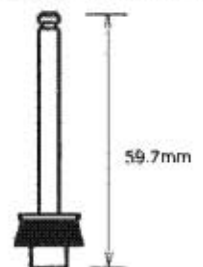

SB-658

Repair Kit Identification

Illustrations - By Main Identifying Components

SU



HS2, 4 Jet size .090"
SU-750

HS6 Jet size .100"
SU-754



HS8 Jet size .100" HS8 Jet size .090" HS8 Jet size .090"
SU-770 SU-773 SU-774



HD4 Jet size .090"
SU-768

HS6 Jet size .100"
SU-769



HIF7 Jet size .100"
SU-771



HIF4 Jet size .090"
SU-759

HIF6 Jet size .100"
SU-760

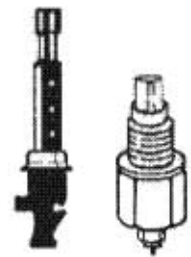

HIF38 Jet size .090"
SU-755



H Series Jet size .090"
SU-765

H Series Jet size .100"
SU-767



HD6 Jet size .100"
SU-763

HD8 Jet size .125"
SU-764

SOLEX

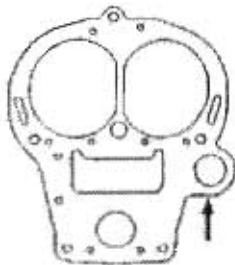

32DIDTA
SX-700

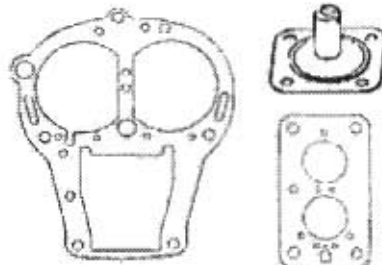

DIDTA
SX-713

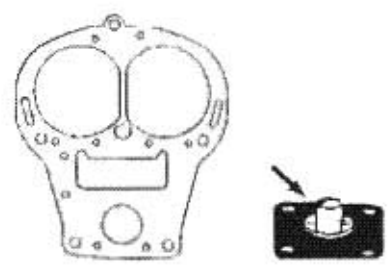

32DIDTA
SX-726

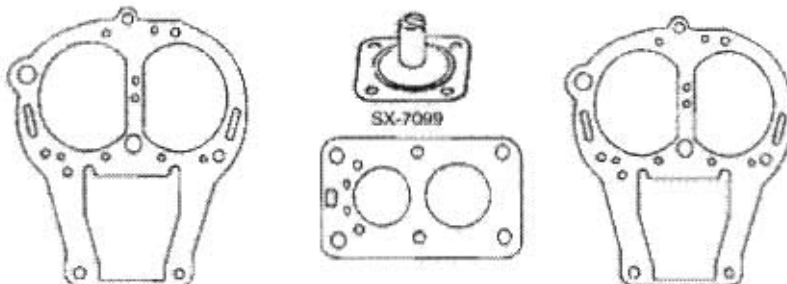

32/35DIDTA, 32/35TDID
SX-7099

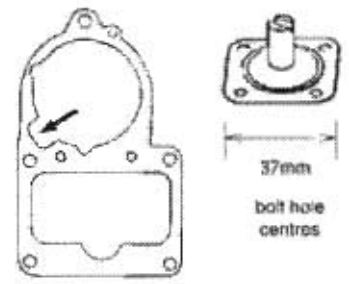

34PICT-4
SX-738

Repair Kit Identification

Illustrations - By Main Identifying Components

SOLEX (Continued)

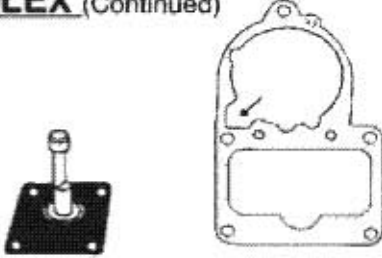

34PICT-5
SX-704

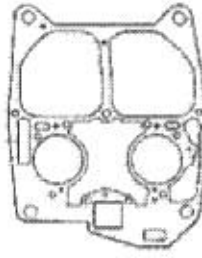

4A1
SX-717

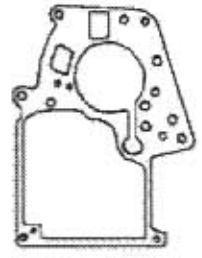

32SEIA, 32EISA-4
SX-723

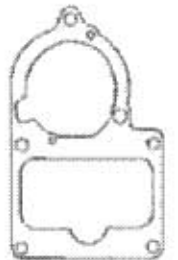
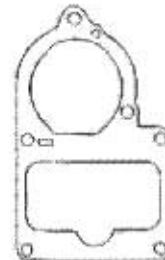
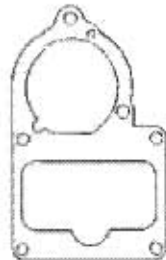
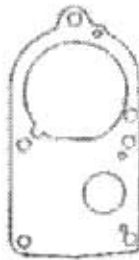
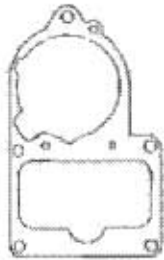

SX-703 28PICT-1, 30PICT-1, 30PICT-2, 30PICT-3, 31PICT-3, 34PICT-3

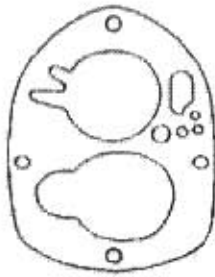

SX-739

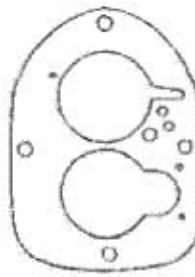

44PAI
SX-742

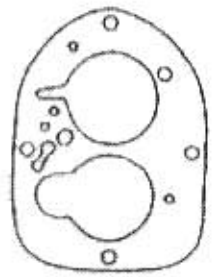

40PAIC
SX-735, SX-735M

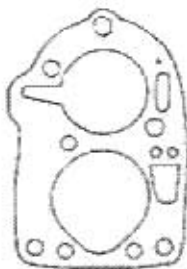

32PICB, 34PICB
SX-736

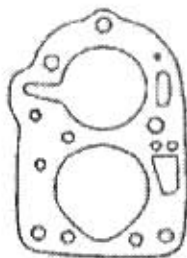
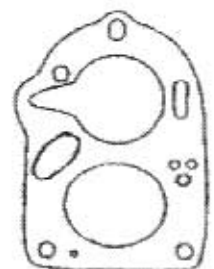

32PBICA, 34PBICA
SX-719

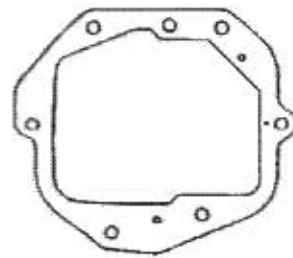

44PHN
SX-743

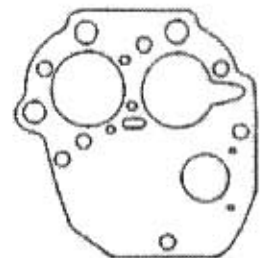

34PAITA
SX-716

Repair Kit Identification

Illustrations - By Main Identifying Components

SOLEX (Continued)

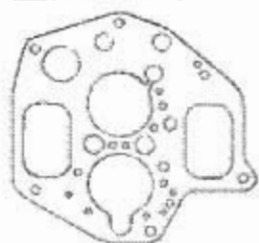

28CIC-4
SX-7059

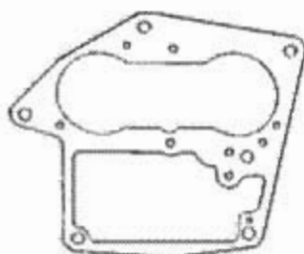

35CEEI
SX-741

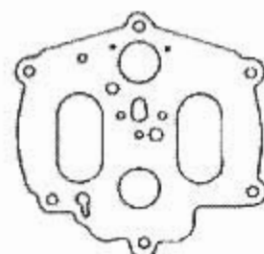

32PHN
SX-707

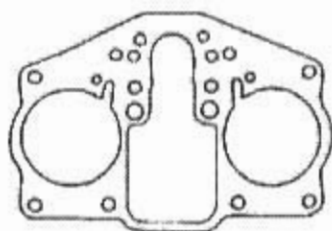

40P11-4
SX-748

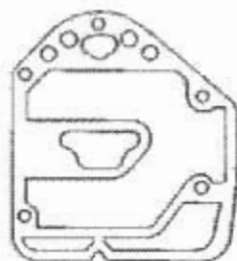

40DDH, 40ADDHE
SX-702

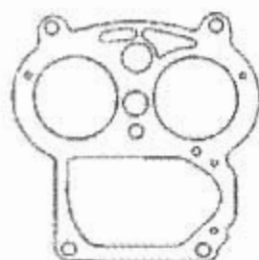
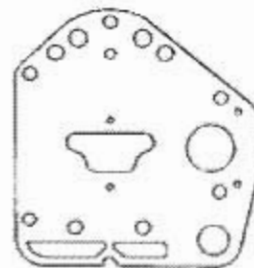

SX-706

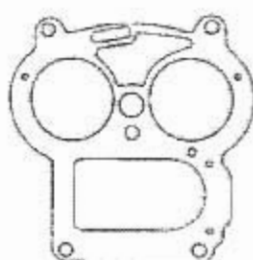

SX-7071

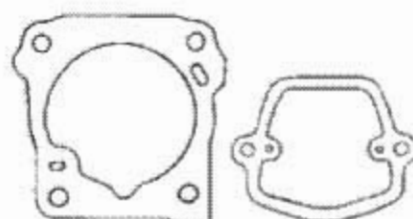

30PHIT
SX-709

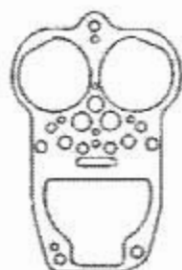

32/35TMIMA, 32/35MIMSA
SX-730A

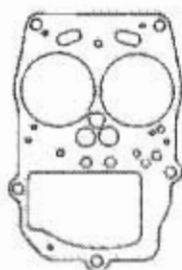

32/35SEIEA
SX-720A

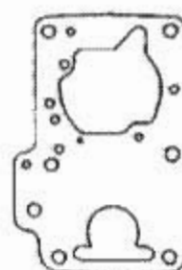

34TBIA
SX-729A

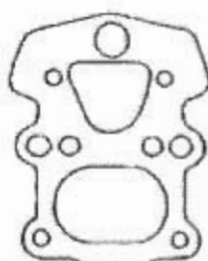

44PHH
SX-737

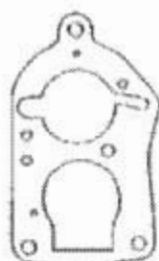

32BICSA, 34BICSA
SX-740

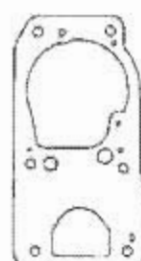

SX-7092

Repair Kit Identification

Illustrations - By Main Identifying Components

SOLEX (Continued)

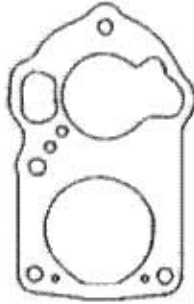

26ZIC, 30ZIC
SX-744A

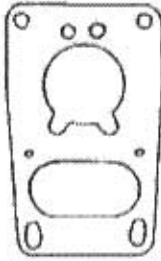
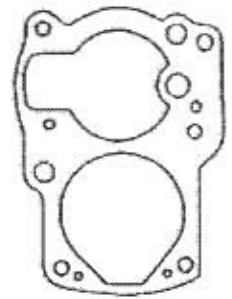
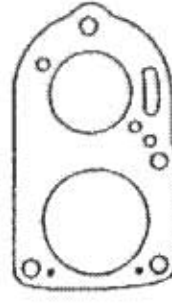

28PCI
SX-746

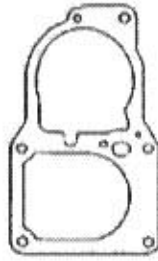

36-40PDSI
SX-714

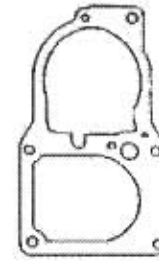
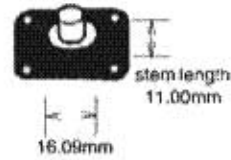

32DISTA, 32DITA
SX-715

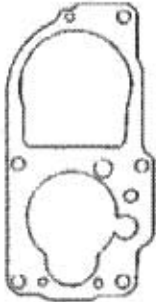
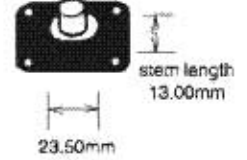

single carburetor

35PDSIT
SX-733

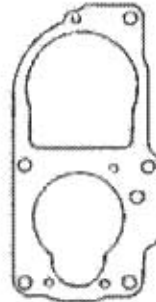

1.20" N/Seat pump
diaphragm stem 14.00mm

32PDSIT-2,3
SX-705

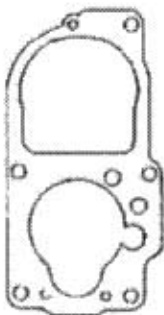

twin carburetors

34PDSIT-2,3, P/Punger height 12.3mm
SX-701

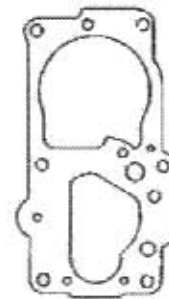
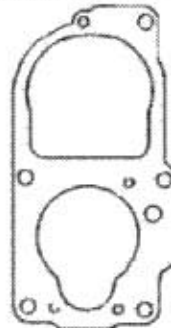

Pump
diaphragm
stem
10.5m

35PDSIT-5
SX-712A

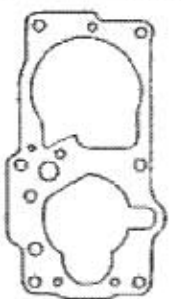

Repair Kit Identification

Illustrations - By Main Identifying Components

WEBER

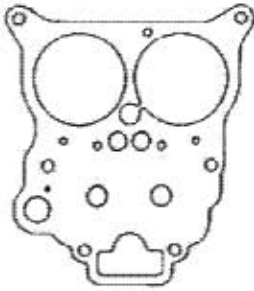

32ADF / ADFA
WE-810

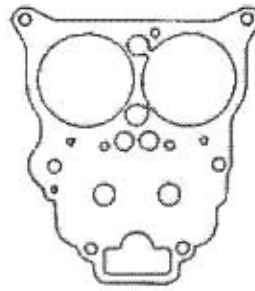

34 ADM
WE-844

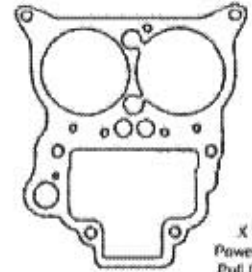

X Kit contains
Power Valve, Choke
Pull Off, A/C Diaph,
Aux. Diaph.
WE-844X

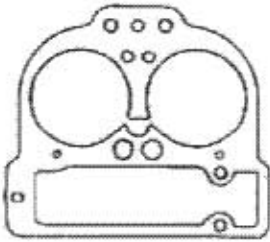

40. 42DCNF
WE-838

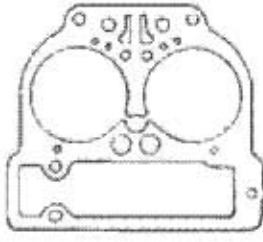

40 DCN
WE-845

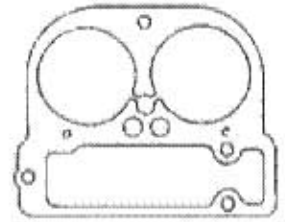

300IC, 1.2, 3.4
WE-846

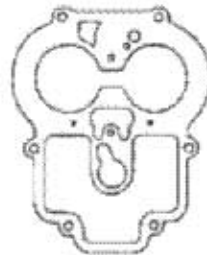

25/36DCD
WE-804

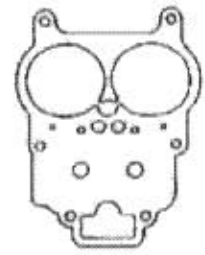

34AD5D
WE-806

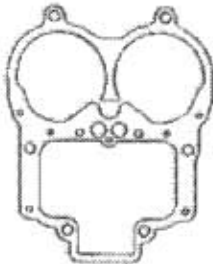

22/36DOV, DGAV
WE-803X

X-Kit contains 1
choke pull off
1 Insulator
1 power piston

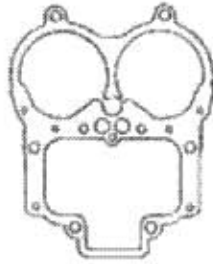

WE-8067 2.5m N/Seal
WE-800, WE-800X



X-Kit contains 1
choke pull off
1 Insulator Block
1 Choke Pull Off
1 power piston

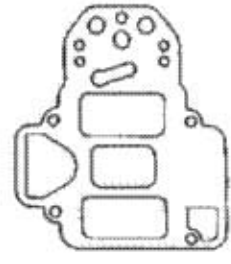

40DCOE, 45DCOE, 48DCOE
WE-805

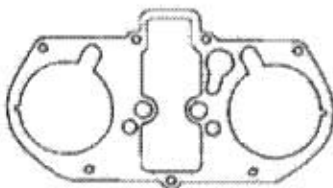

48IDA
WE-848

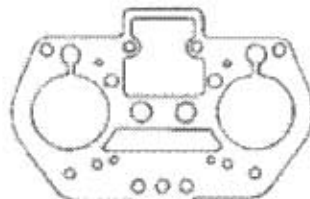

35IDF
WE-8081

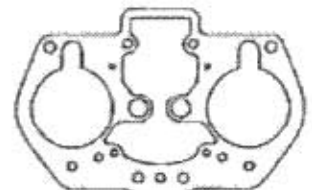

43DF, 44DF, 48DF
Exc. 40IDF 50 44IDF 81, 48IDF 8, with 47407.207 pump
WE-834A

Repair Kit Identification

Illustrations - By Main Identifying Components

WEBER (continued)

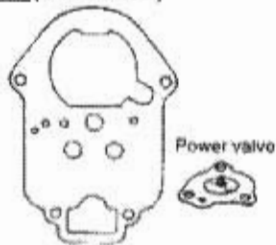

321CH, 341CH, 341CT
WE-8083

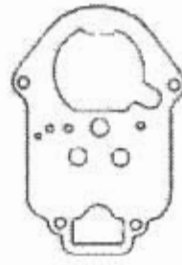

32/34ICT
WE-801

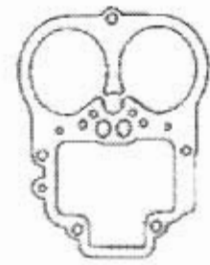

32/36DFV
WE-812

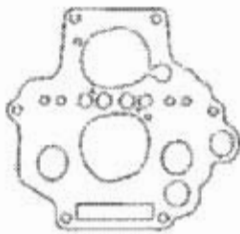

32DATR, A, 32DAT, A, 34DATR, A, 34DAT, A
WE-822

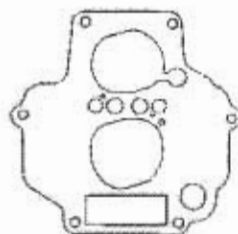

32/34DMTL, 34DMTR
WE-8074

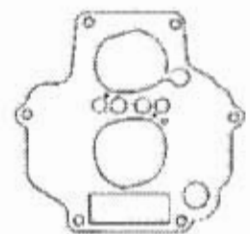

32/34DMTT
WE-815

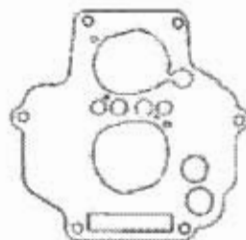
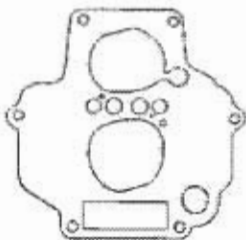

34DMTR, 32/34DMTRA, 34DMTR
WE-818

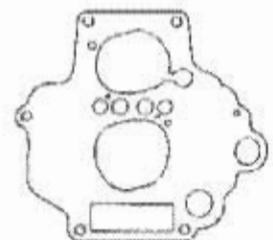

32DATRA, 34DATRA
WE-832A

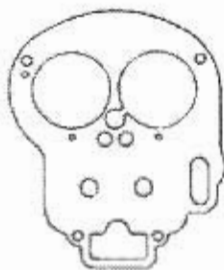

28/36DDE, DOA, DLE, DLA, DM, DMA
WE-8082

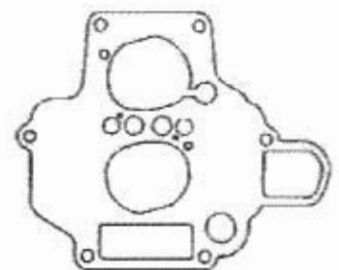

32/34DFT
WE-813

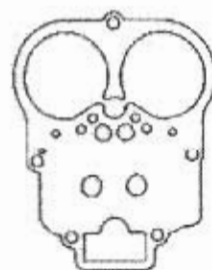
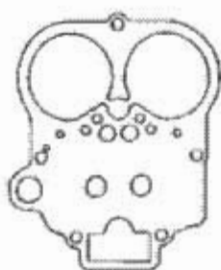

32DHS, 34DHS
WE-814

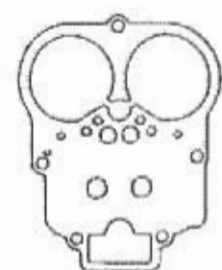

WE-802 32DFD, DFE, DFM
WE-825 34DMS

Repair Kit Identification

Illustrations - By Main Identifying Components

WEBER (continued)

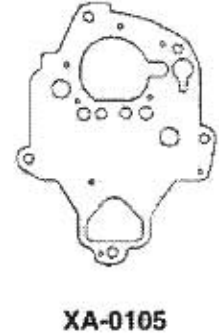
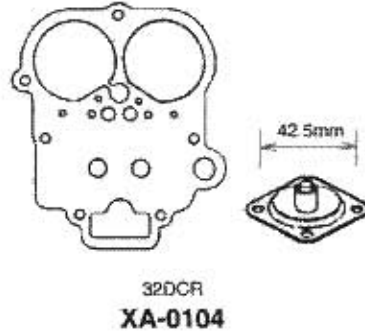
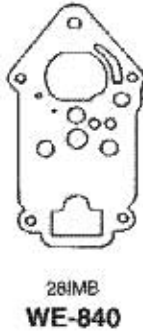
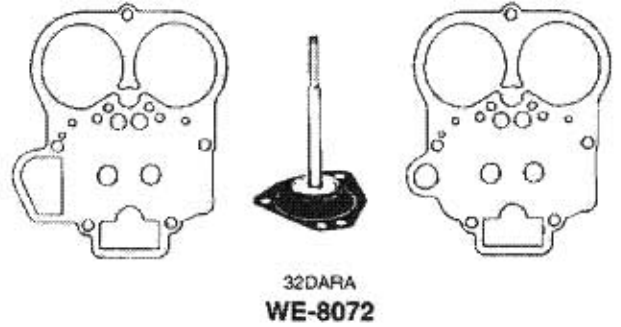
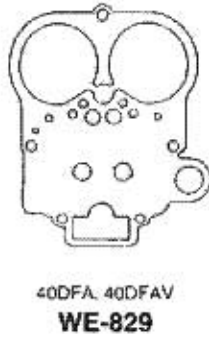
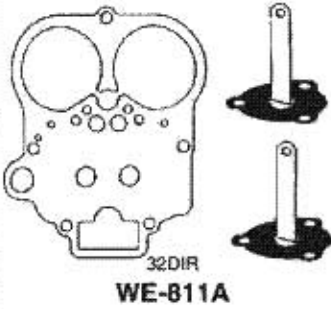

ZENITH

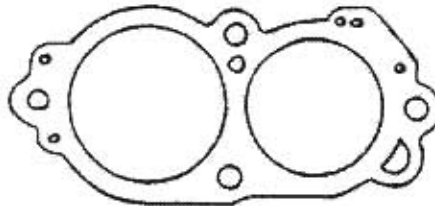

This intermediate gasket
supersedes all others

ZE-850A
ZE-854A
ZE-854X
ZE-855A
ZE-857A

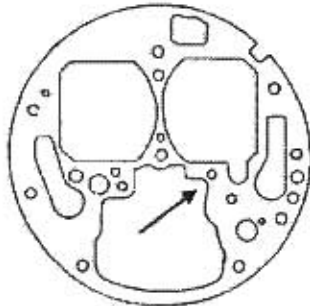

Power Piston



GMH Sunbird
1900 Opel

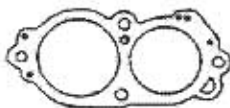

35/40INAT
ZE-850A

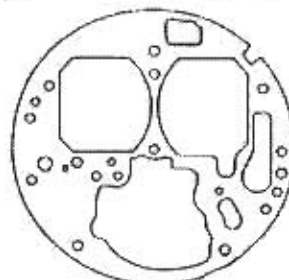
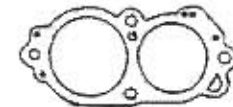
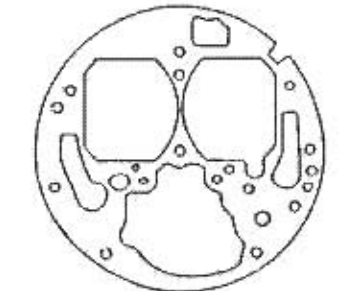

ZE-857A

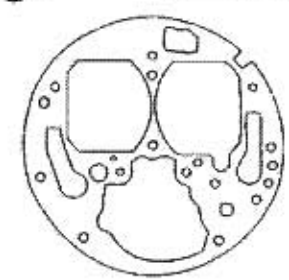
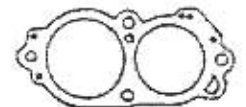
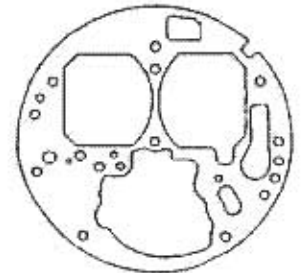

ZE-855A

Repair Kit Identification

Illustrations - By Main Identifying Components

ZENITH (continued)

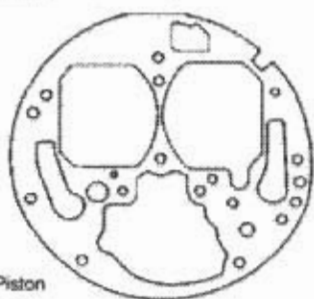

Power Piston

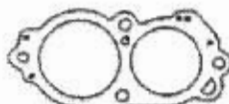

35/40INAT, 35/42INAT

ZE-854A

ZE-854X includes power piston

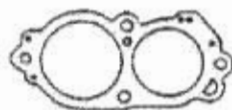
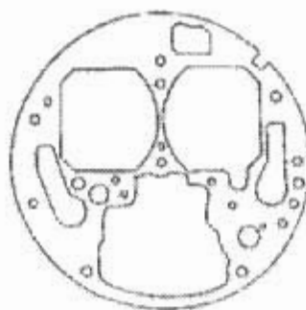

ZE-865

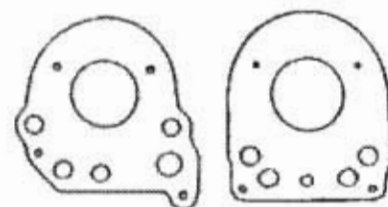

ZE-863

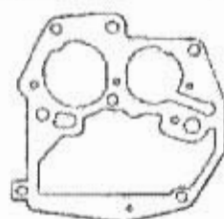

ZE-8602

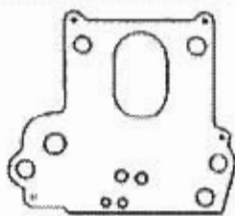

30VN, 32VNP, 33VN, 34VN, 37VNR, 42VNT

ZE-851

ZE-851A with pump plunger

ZE-851X 2.5mm N/Seal

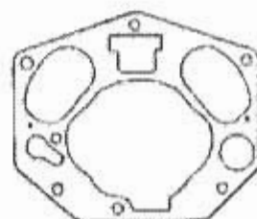

32NDIX

ZE-861

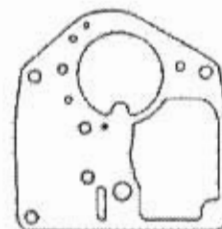

34IV, 36IV, 36IVT

ZE-852

ZE-852M with throttle shaft, disc & screws

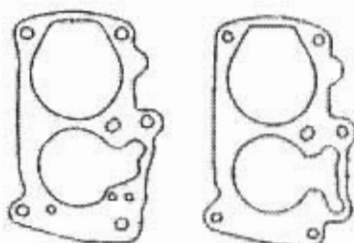

30PSE, 33PSEI

ZE-853

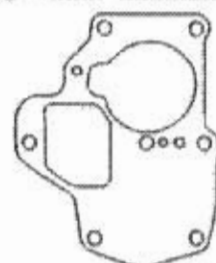

34WIA, 36WIA, 36WIP

ZE-860

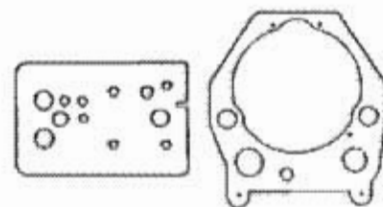

36VIS, 42VIS, 42VIR, 48VIR

ZE-864A

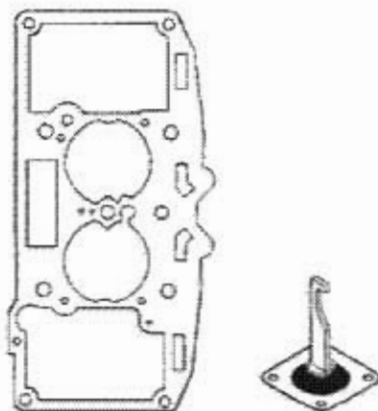

34/34 2B2, E17411

ZE-8600

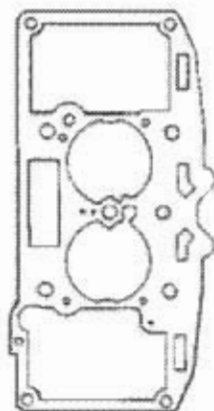

34/34 2B2, E17412

ZE-8607

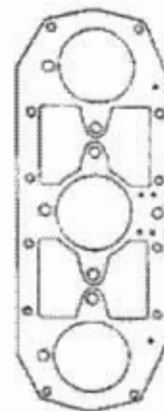

40TIN

ZE-862