



ADW SPORTS

SPORTS & ENTERTAINMENT DIVISION OF
ADMIRALWORLD GENERAL TRADING LLC



NOHRD



WaterRower

Wooden Fitness Innovations

NOHRD Bike
Indoor Cycle / NEW

WaterRower

pp 4-17



SlimBeam

pp 18-27



NOHrD Bike

pp 28-31



WaterGrinder

pp 32-37



SwingBells

pp 38-43



HaptikBall

pp 44-45



WallBars

pp 46-53



W-Workx

pp 54-59



TriaTrainer

pp 60-67

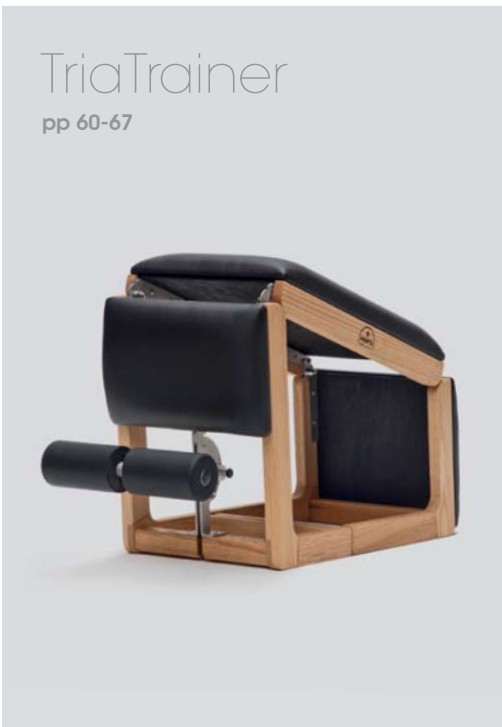

HedgeHock

pp 68-69



NOHrD Wall

pp 72-74



Eau-Me Board

pp 70-71



Sprintbok

pp 76-77

NEW

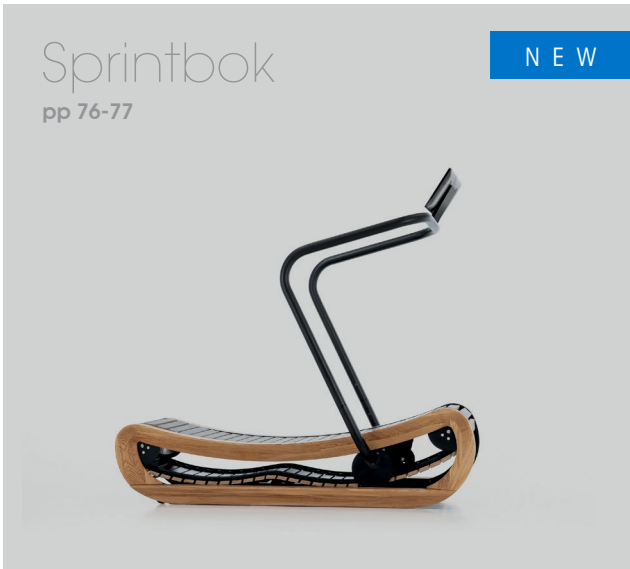

Elasko

pp 78-79

NEW







WaterRower

Rowing Machine / **Water Resistance**





WaterRower

Rowing Machine / **The Intelligence of Water Resistance**

WaterRower rowing machines have been manufactured with utmost care and attention to detail for the last 30 years, representing high-end quality and design in the home, workplace and fitness studio.

Its signature water tank provides visual, as well as acoustic feedback during your workout, while water's natural resistance constantly adapts to the user's strength input. If preferred, the WaterRower can be easily stood in an upright position for storage.

THE ORIGINAL
SINCE 1988



WE-ROW 



- 1 Intelligence of water resistance: resistance levels automatically adapt to user
- 2 S4 Performance monitor with USB port: suitable for rowing software We-Row
- 3 Ideal space-saver: requires less than 1 sq meter when stood upright
- 4 From beginner to pro: suitable for all ages and levels of fitness

Technical Details

- "intelligent", adjustment-free, resistance
- max. 20 liters water
- upright storage
- weight without water: approx. 30 kg / 66 lb

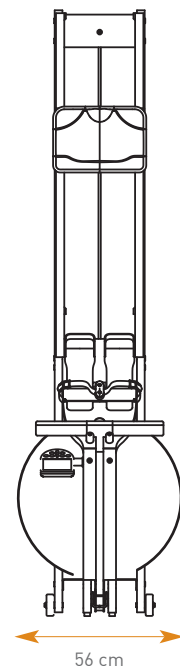
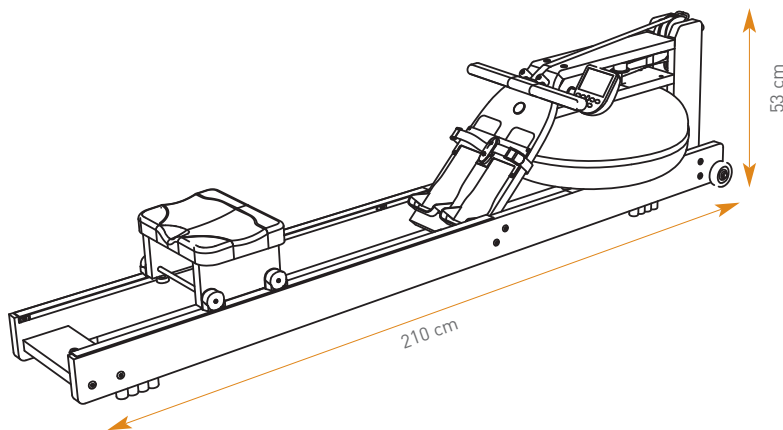

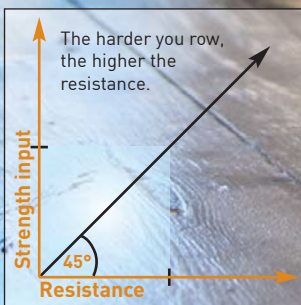
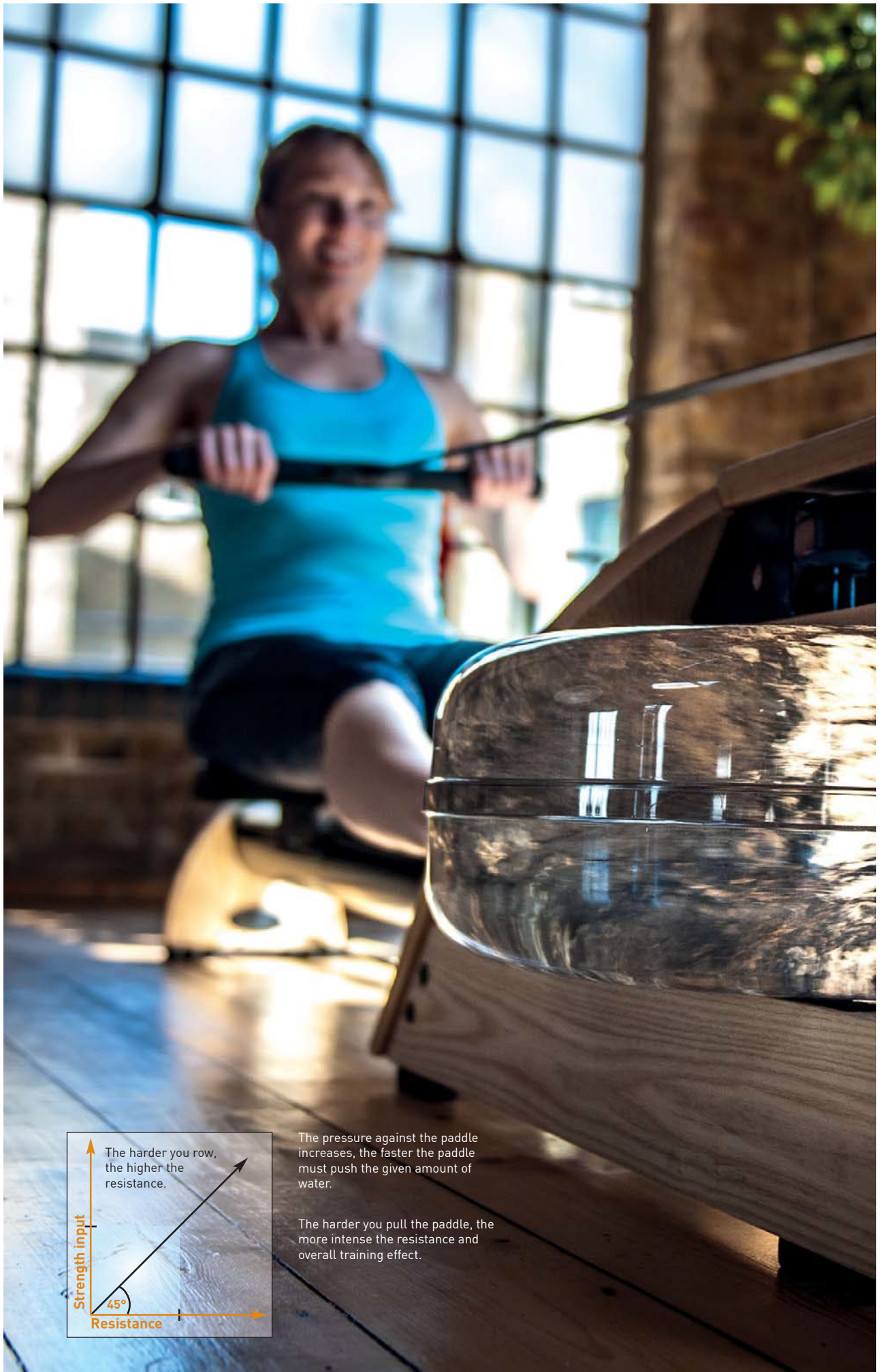

The harder you row, the higher the resistance.

The pressure against the paddle increases, the faster the paddle must push the given amount of water.

The harder you pull the paddle, the more intense the resistance and overall training effect.

WaterRower

Water Resistance / Patented Technology



The heart of the WaterRower is the water tank with its ergonomically shaped paddle. This provides for a maximal movement of water, with smooth, jerk-free resistance. In this sense, water acts as an 'intelligent' form of resistance, able to precisely adapt to the user's individual input.

Pulling slowly will decrease resistance. Increasing your stroke speed will intensify resistance, which will remain smooth and gentle on the joints throughout. In rowing, the skiff propels through water based on the sculler's strength input. The WaterRower therefore guarantees ideal rowing simulation through its use of water for resistance.

The advantages of water resistance:

- water is gentle and protects the joints
- resistance is finely tuneable and 100% self-determined
- the sound of the water's rhythmic flow during exercise is soothing to the mind

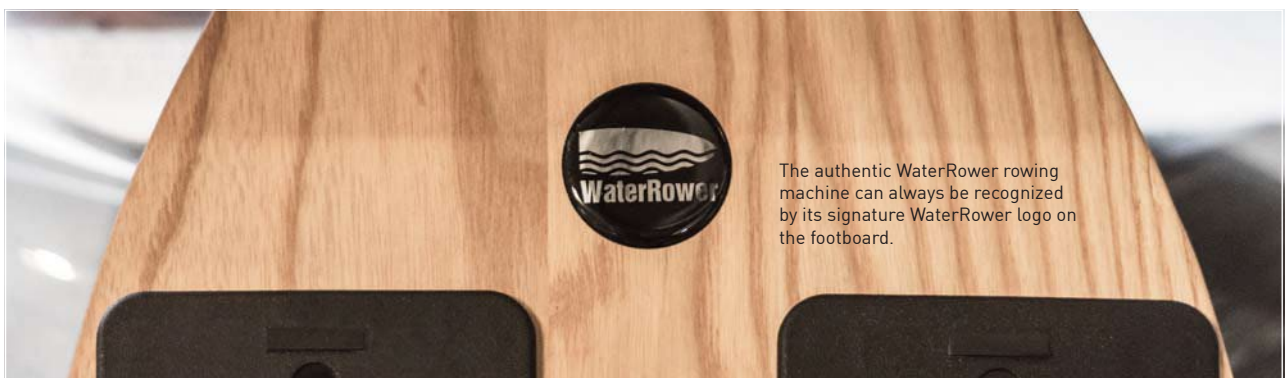

The authentic WaterRower rowing machine can always be recognized by its signature WaterRower logo on the footboard.

WaterRower

Strength and Endurance / **Highly Effective**

Rowing is a highly efficient form of exercise, guaranteed to effectively increase physical performance. Rowing training simultaneously works 84% of the body's musculature, including quads, glutes, abs and back. Resulting, well defined muscles can help prevent arthroses or posture problems.

Rowing exercise promotes functional muscles, contributing to better athletic performance and optimal posture. Thanks to the specific demands inherent to rowing, this workout will ensure efficient cardiovascular training.

These results, along with rowing's high calorie burning attributes, cannot be achieved on the stationary bike or cross trainer. For the record: this machine's undisputed fun factor is training with water resistance.





Most sports tend to build either strength or endurance, usually requiring a significant amount of time to condition one, then the other.

Rowing exercise can offer the ideal solution, with a single session delivering the necessary strength and endurance stimuli for a balanced increase of fitness, yielding high results in minimal time.



Low impact: due to its fluid motion, rowing is especially easy on the joints.



Rowing engages 84% of the body's musculature: abs, legs, glutes, back, shoulders and arms.

WaterRower

Performance Monitor / Software

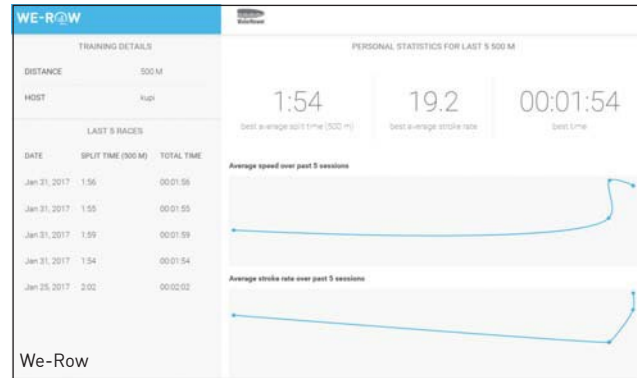

Take advantage of the S4 Performance Monitor for all your rowing data at a glance. The monitor was specially developed for training on the WaterRower. During your workout, the S4 Monitor displays the following data: strokes per minute, length of rowing session, intensity in meters per second (m/s) or in miles per hour (mph), distance rowed in kilometers or meters and optionally, when connected to a chest strap and receiver: your heart rate. The indicated figures are configurable, allowing users to choose, for example, between kilometers and meters.

The WaterRower S4 Monitor further lets you program your training session: select between distance, time and interval training. Recovery phases are integrated into the distance and time training units. Upon completing your training session, performance statistics and analysis are displayed.



The S4-Performance Monitor can also be used with the free rowing software, We-Row. We-Row is an optional program on Google Chrome which enables WaterRower users to race against each other, as well as have private training sessions configured.

If you like, your rowing data can be stored to a database, available for call-up at any time and enabling you to chart your progress or share with other users.

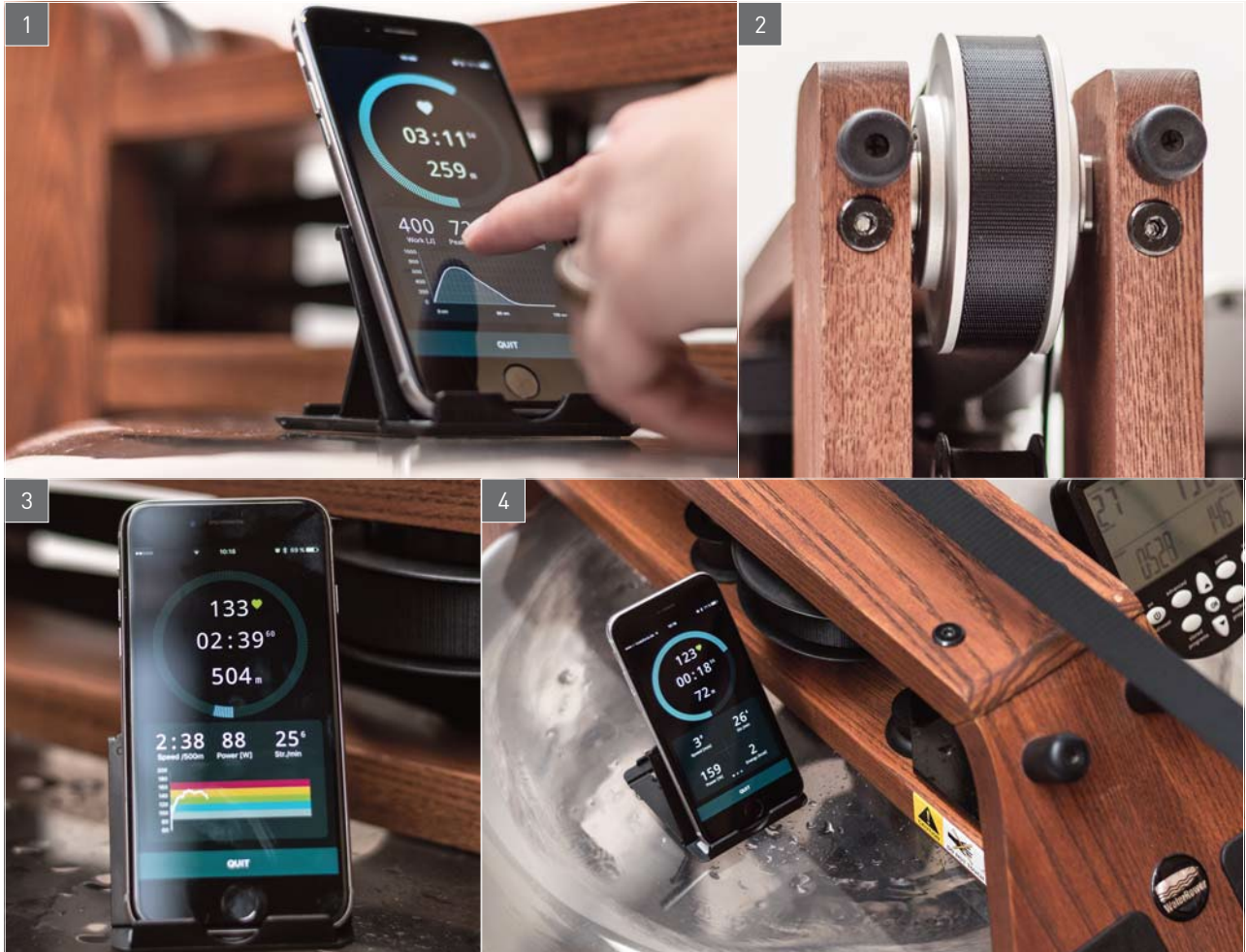

- 1 Review all training data at a glance – further to performance, time, distance and heart rate are determined and displayed
- 2 The SmartRow pulley is fastened directly to the WaterRower by two brackets, in place of the main pulley
- 3 Three different interfaces provide an optimal overview during your rowing workout
- 4 SmartRow delivery includes a phone stand to ensure practical and sturdy smartphone positioning on your WaterRower

Smart Row

Download as App / Complete Comparability

The ideal accessory for your WaterRower: SmartRow records your training data with even more precision – directly to your smartphone! The SmartRow device replaces the WaterRower's main pulley, and transfers -via strain gauge- your strength input during rowing into a measurable unit.

SmartRow Advantages

SmartRow's technology makes your training sessions and results 100% comparable between each WaterRower machine, regardless of the level of water used. Users' data on time, distance, stroke number and calories is displayed and saved from each workout for easy potential and progress analysis. Heart rate can also be monitored and displayed when using the appropriate chest strap or watch.

Currently, SmartRow is only compatible with iOS devices – porting to Android systems is in progress.

Strain Gauge

The most important elements are strength input, distance rowed and time required – the value is determined from these three components and displayed in watt. The SmartRow's built-in strain gauges can, for the first time, measure and display exact results, rendering your training sessions on the WaterRower complete comparability among WaterRower machines.

WaterRower

Technical data / Details

WaterRower Rowing Machines	Wood Models	M1 HiRise M1 LoRise	S1 Stainless Steel	A1
Dimensions in cm	210 x 56 x 53	223 x 56 x 69 223 x 56 x 53	210 x 56 x 53	215 x 56 x 53
Weight in kg (without water)	30,5	36,0 33,5	40,0	28,0
Seat height in cm	31,0	51,0 33,5	30,0	26,0
Max. weight limit in kg	150	180	180	130
Max. water limit in l	20	20	20	20
# of rails	2	2	2	1
We-Row compatible	yes	yes	yes	no
Upright storage	yes	yes	yes	yes
# packages with delivery	2	2	2	2
Monitor version	S4, USB	S4, USB	S4, USB	kein USB
Materials	wood	aluminum	stainless steel, electropolished	wood, aluminum
Recommended use	home, studio	Studio	Privat, Studio	Privat, Studio
Use with laptop holder	yes	no	no	yes
Use with HiRise adapter	yes	no	yes	no
Fitted cover available	yes	no	yes	no



WaterRower

Model Overview / Price Information



A1



S1 Stainless Steel



Oak



M1 LoRise



Ash



M1 HiRise



Club

Model	Order-Nr
A1	10113
Oak	10107
Ash	10100
Club	10103
Shadow	10105
Cherry	10106
Walnut	10108
S1 Stainless Steel	10110
M1 LoRise	10111
M1 HiRise	10112



Shadow



Cherry



Walnut

All WaterRower models are manufactured with high grade materials and hand-assembled, guaranteeing top quality in every detail.

Delivery is made in two packages. Assembly is easy to follow- complete with owner's manual featuring illustrated rowing technique instruction.

All WaterRower models are manufactured with high grade materials and hand-assembled, guaranteeing top quality in every detail.

Delivery is made in two packages. Assembly is easy to follow- complete with owner's manual featuring illustrated rowing technique instruction.



WaterRower

Accessories / Extensions



ACCESSORIES / EXTENSIONS

Digitally coded 2.4 Ghz connection for heart rate monitoring. The S4 Performance Monitor is extended by a connector for wireless reception from the coupled transmitter (chest strap).

10306



POLAR CHEST STRAP

The chest strap (heart rate transmitter) sends your data to the heart rate receiver or compatible watch.

10307



POLAR HEART RATE RECEIVER

Connects by cable to the WaterRower Performance Monitor. Transmits received data to the S4 Monitor.

10305



LAPTOP HOLDER

Laptop holder made of wood, fits on the WaterRower top deck. Safety ridge protects laptop from slipping. Suitable for laptops up to 17" and tablets up to max. width of 24 cm. Dimensions in cm: 38x28x22

- 10217 (Oak)
- 10212 (Ash)
- 10213 (Club)
- 10214 (Cherry)
- 10215 (Walnut)
- 10224 (Shadow)



XL-RAILS

All WaterRower models available in XL-version, suitable for users 6'5" and taller (2m). XL rails can also be combined with the HiRise Adapter.

- 10218 (Oak)
- 10200 (Ash)
- 10202 (Club)
- 10203 (Cherry)
- 10204 (Walnut)
- 10225 (Shadow)

HIRISE-ADAPTER

The HiRise-Adapter increases sitting height by 20cm, making standing up from/sitting down on machine more comfortable.

- 10219 (Oak)
- 10206 (Ash)
- 10208 (Club / Shadow)
- 10209 (Cherry)
- 10210 (Walnut)





CARE KIT

The perfect set for the care and maintenance of your WaterRower.

Includes:

- 1 cleaning spray (synthetics)
- 1 cleaning oil (wood)
- 3 cotton cloths
- 1 sanding fleece
- 1 year supply chloride tablets

10304



1-YEAR PACKET CHLORIDE TABLETS

Slow-dissolving, quality care tablets. Use one tablet every two months to keep your water tank free of lime deposit and residue. 6 tablets per packet.

10313



BLUE WATER DYE

One full bottle per dosage adds a wonderful, deep blue hue to your WaterRower's water. Do not use with chloride tablets!

10303



OARSOME ROWING GRIPS

Put over each end of the handlebar for the best protection against chafed hands. The ergonomically shaped, extremely soft grips are specially made to always maintain their original form.

10315



FITTED COVER

The WaterRower fitted cover is easy to put on the rowing machine, providing protection against the elements, such as dust, rain or high levels of humidity.

10300



FLOOR MAT

Our floor mat prevents the WaterRower from slipping on especially smooth or delicate surfaces, while protecting your floor. Dimensions in cm: 228 x 90 x 0.5

10301



ROWING TECHNIQUE DVD

Featuring Xeno Müller, Olympic Gold and Silver rowing medalist! This instruction on the correct rowing technique shows you how to efficiently improve your fitness levels using the WaterRower.

10312



ERGO- SEAT CUSHION

Relieves pressure and significantly increases seat comfort. The ergo-seat cushion is specially designed to meet the demands of rowing exercise and is suitable for all WaterRower seats.

10317



SMARTROW

The WaterRower Smart Row extension delivers 100% comparable data on your rowing exercise - independently of the monitor- directly to your smartphone.

10226



+X
PLUS X AWARD™



SlimBeam

Cable Machine / **Fitness Tower**



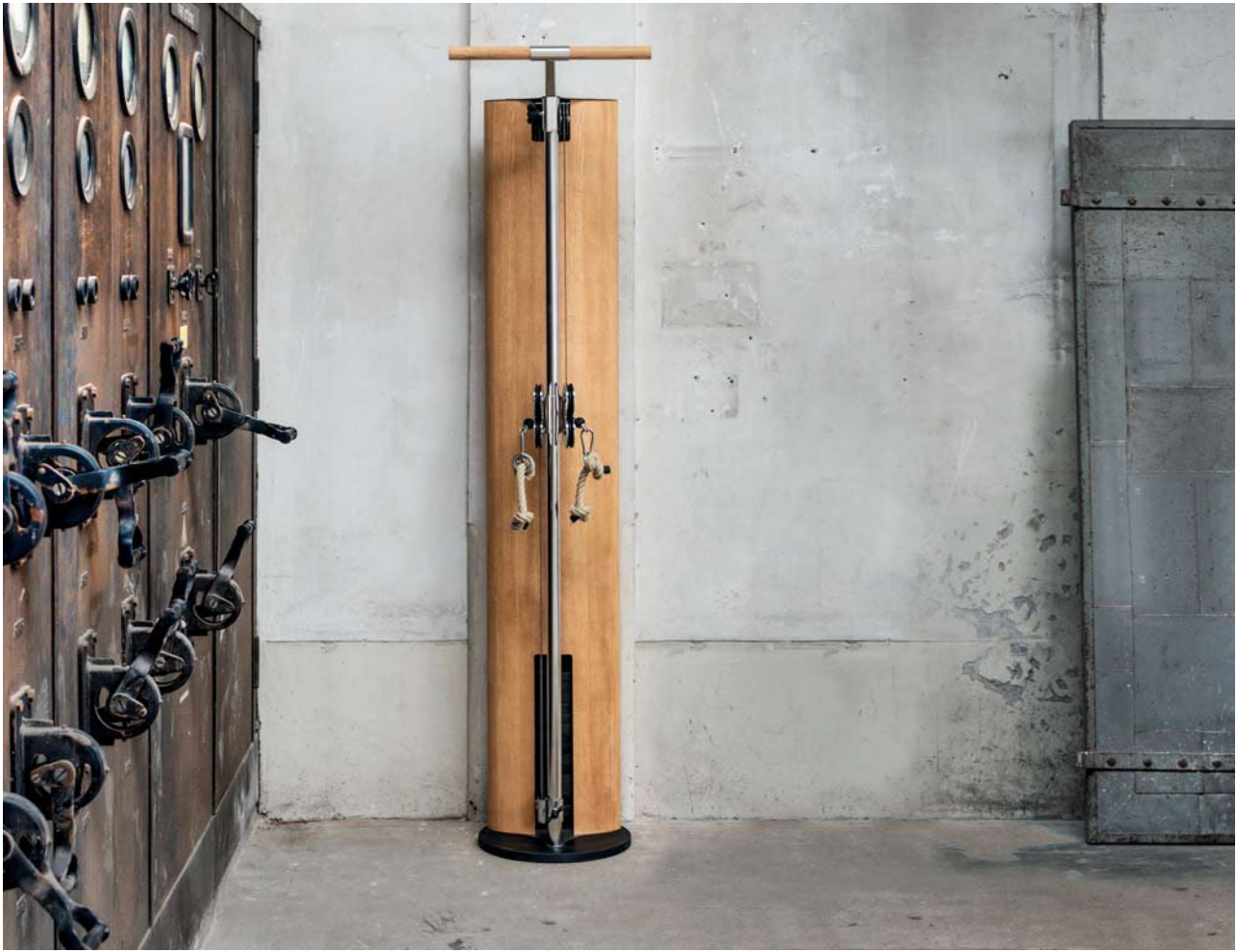

SlimBeam

Cable Machine / **Fitness Tower**

Cable machines are both versatile and multi-functional and are not a classic among fitness equipment for no reason. Fitness and physiotherapy centers alike have been relying on the use of cable equipment for years.

The SlimBeam cuts a fine figure in home fitness, combining stylish design and complete functionality into a single, sleek encasement. The SlimBeam boasts smooth contours in a curved form out of high-grade wood, giving you a professional cable exercise station ideal for functional training.

The butterfly is the SlimBeam's main feature, enabling you to train on both sides. It can swivel to meet any standing position and is adjustable in height.



- 1 The optional electronic training guide features each exercise in video form
- 2 Weight plates are rubberized to ensure non-clanking noise during exercise
- 3 The butterfly enables exercising on both sides, swivels and is easily adjustable to any height
- 4 The exercise bench is optional and can be hung onto the machine at any height

Technical Details

- 14 weight plates at 5kg each + base weight
- SlimBeam total weight: 120 kg

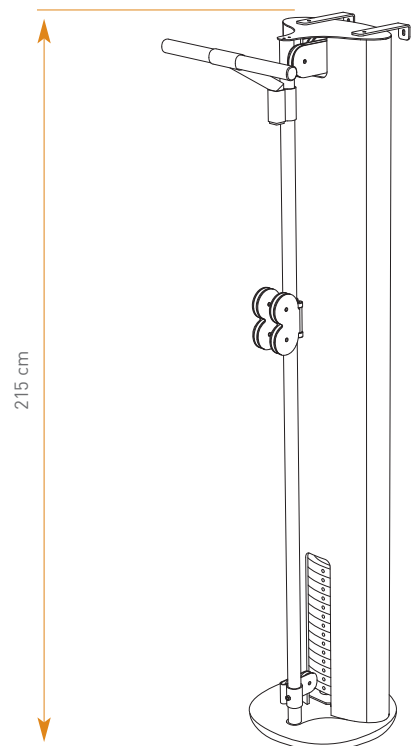
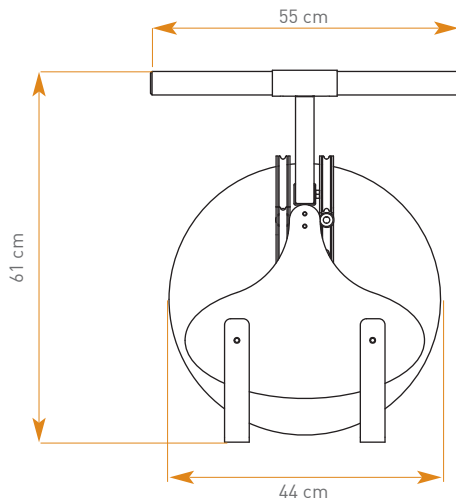

SlimBeam

Exercise App / Includes Videos

In addition to the exercise manual, the SlimBeam can be used with the interactive SlimBeam exercise app for Android tablets. The tablet holder is sold separately and attached to the SlimBeam's frame on the side of the machine at any time.

To use the app, simply connect your android tablet via USB port and download the exercise app. During your workout, your set weight and reps, as well as cable length are automatically recognized and clearly displayed. Each exercise is featured, in detail, in video.

Function Overview:

- weight recognition
- repetitions displayed
- total weight pulled displayed
- suggested weight settings
- suggested butterfly settings
- full-body workouts
- isolated exercises
- instructional videos
- Android compatible
- tablet holder sold separately
- cable ratio / cable length
- graph display of your weight pulled
- personal profile with exercise overview



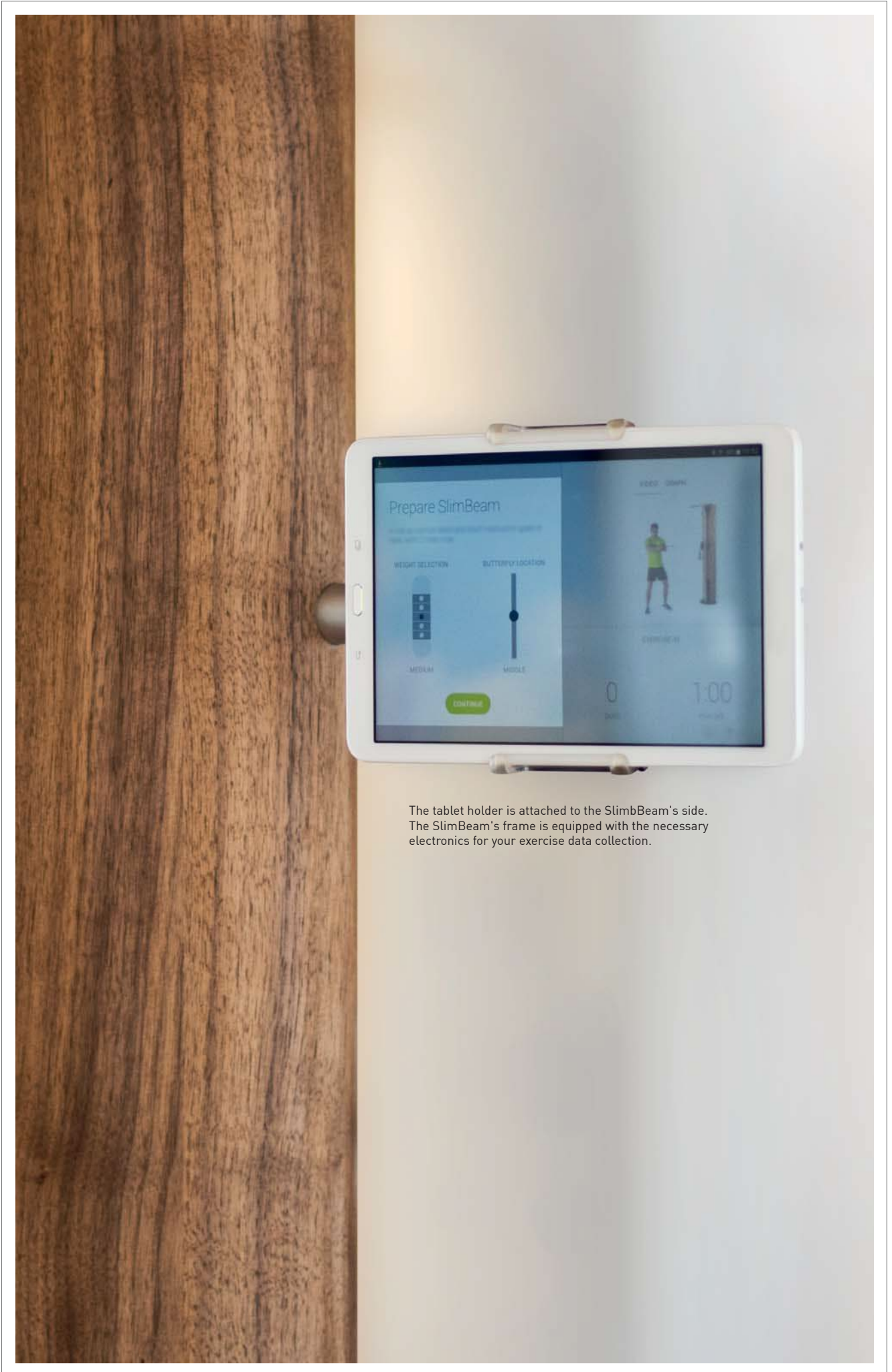

The tablet holder is attached to the SlimBeam's side. The SlimBeam's frame is equipped with the necessary electronics for your exercise data collection.

SlimBeam

Training / Exercising

Cable machine training truly expands the realm of strength training. Classic weight stations typically enable only a set direction of movement, while cable machines provide much more range of movement in weight training. Each exercise can be performed at different heights and angles, drastically increasing the number of possible exercises and range of motion.

Advantages of cable training

- increases stability
- multiple muscle groups worked simultaneously
- increases coordination
- increases core strength through continuous core engagement
- adjustable features enable wide range of movement during exercise

NOHRD SlimBeam cable ratios can be set to enable pulling up to a length of 8m - ideal for conditioning a golf or tennis stroke. An increase in the rubberized weight plates and various butterfly adjustments will heighten your workout's intensity.

No matter the butterfly setting: pulling vertically, diagonally or horizontally is not a problem and will enable you to get the most out of the wide range of exercise possibilities.



Extension	3:1 cable ratio kg	2:1 cable ratio kg	1:1 cable ratio kg
Single	0,83 - 12,50	1,25 - 18,75	2,50 - 37,50
Double	1,65 - 25,00	2,50 - 37,50	5,00 - 75,00

The cable ratio can be changed through the amount of rolls provided for use. The SlimBeam can be converted for this. A separate pulling cable is required.



SlimBeam

Model Overview / Price Information



Ash



Club



Oak



Cherry



Walnut



White



Black



Stainless Steel

Models	Order No.
Ash	15.100
Club	15.101
Oak	15.106
Cherry	15.103
Walnut	15.104
Stainless steel	15.105
White*	15.110
Black	15.112

- * Further colors/materials available.
- * SlimBeam white/color is coated with high pressure laminate (HPL).
- * SlimBeam black is stained oakwood veneer.

Technical Details

Base plate:	ø 44 cm
Height:	215 cm
Width:	40 cm
Depth:	20 cm
Distance to wall:	10 cm
14 weights:	je 5 kg
1 start weight:	5 kg
Total weight:	ca. 120 kg
Ratio:	3:1

Equipment included:
Pull-up bar with adapter, cord

SlimBeam

Accessories / Extensions



Exercise bench
features foldout legs, black

Artificial leather	15214
Genuine leather	15215



Pull-up bar

Black	15228
Ash	15229
Club	15230
Oak	15232
Cherry	15233
Walnut	15234



Extension handles

Black	15208
Ash	15222
Club	15223
Oak	15225
Cherry	15226
Walnut	15227



Equipment adapter
The equipment adapter is attached to the front bar and is height-adjustable.

15201



Aluminum lat bar
Lat bar made of featherweight aluminum with a ribbed surface for an optimal grip. Use for back, upper core and lat exercises. Length: approx. 120cm

15216



Ankle strap
Made of high quality artificial leather with felt lining.

Natural	15207
Black	15250



Cleaning set
3x microfiber cloths, 1x abrasive fabric
1x wood care oil, 1x metal emulsion

15210



Lubricant
For use in case of pulling hitches.
Content 400ml. Lubricates and protects.

15211



Electronic training system *
Includes universal tablet holder (android) for sizes up to 13". Main frame only / tablet not included

15236



Cable for ratio
Available in different lengths for various transformation ratios. (3:1 is standard length).

3:1 ratio	15204
2:1 ratio	15205
1:1 ratio	15206



Ceiling clamp
Use for various ceiling heights.

232 - 242 cm	15218
241 - 259 cm	15219
258 - 276 cm	15220



Lat upgrade set
Extension for pull-up bar by 2 wheels for lat exercises.

15217

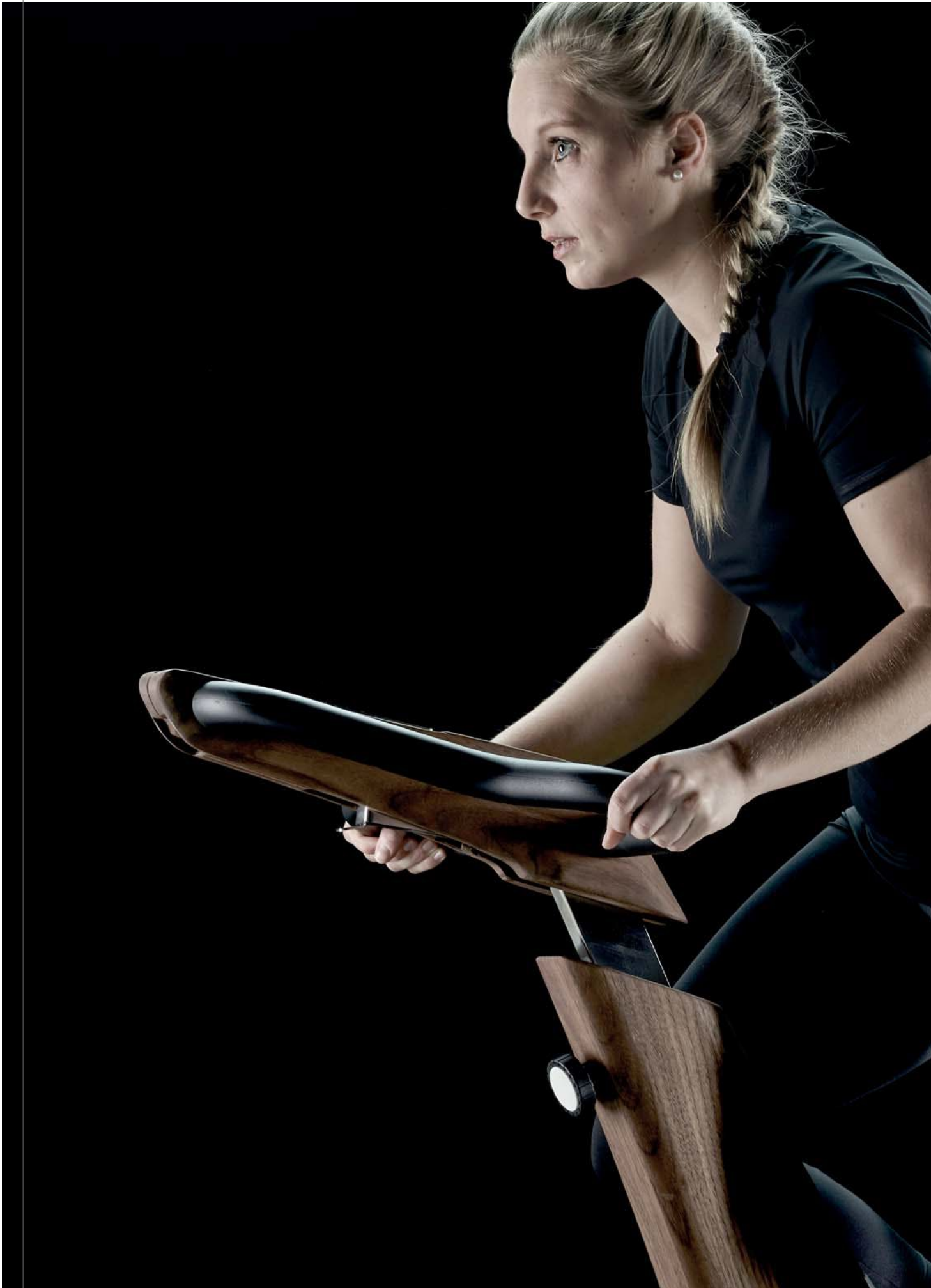

NOHrD Bike

Indoor Cycle / **When Design Meets Function**





NOHrD Bike

Innovative Design / High-standard Functionality

Introducing the NOHrD Bike – an indoor cycle with an innovative, aesthetic design adhering to our continuous high demands on functionality. Using advanced planetary gearing with a solid wood and steel frame, this bike is extremely durable, perfectly suited for professional use in the fitness studio or home gym.

Having pursued a minimalist, sleek design inherent to athletic cycling, the NOHrD Bike boasts an impressive, clear structure with a distinct flow. Cyclists will appreciate being able to train in both an upright or racing position, for which the handlebar provides various grip possibilities and can be adjusted for a range of cycling angles.



- 1 The NOHrD Bike App is free of charge and both Android and IOS compatible – keep an eye on your fitness
- 2 The handlebar provides sufficient grip possibilities and a comfortable, safe support during exercise
- 3 Exercise at your desk? Not a problem – the NOHrD Bike laptop tray accessory converts your bike into a veritable work station
- 4 Your bike - your settings: seat and handlebar easy to adjust; alter intensity - also during cycling - by turning the settings disc

The NOHrD Bike technical features include an innovative gear unit, as well as a smooth, wear-free break technology based on eddy current, guaranteeing extraordinary durability. Pedal stroke resistance is infinitely variable by turning the settings disc. The specially developed app records your cycle workout data and transmits to your tablet via Bluetooth, enabling the user to precisely track and analyse performance. Simply click your device into the practical tablet holder for safe and sturdy viewing during training to see your data at a glance.

The NOHrD Bike is designed for maximal stability within minimal space: requiring a mere 0.44 sq meters, this piece of exercise equipment seamlessly fits into any interior environment. The foot sections are equipped with rubberized rollers for easy raising and positioning.

For further details and pre-order information contact: Tel. +971 50 865 6575

WaterGrinder

Upper Body Fitness Trainer / **Water Resistance**

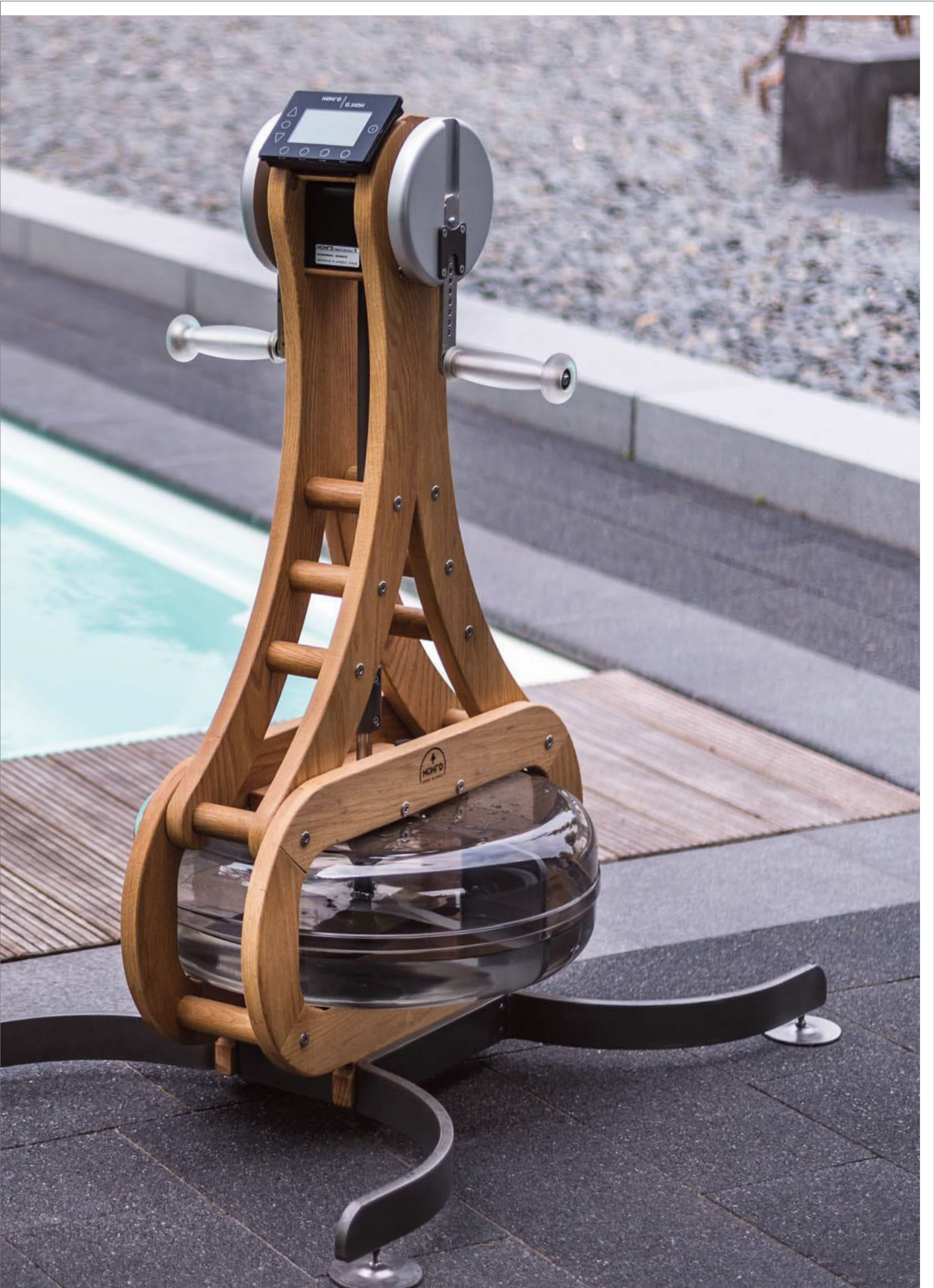



WaterGrinder

Upper Body Fitness Trainer / **Water Resistance**

In sailing, it is the grinder's task to transform wind into propulsion by hoisting the sails as fast as possible.

Grinders do the back-breaking work on board. High-performance athletes that they are, grinders' strength and condition work the winches on racing yachts to raise the sails.

The most effective way to do this is by a classic cranking motion. The NOHrD WaterGrinder enables you to practice this sport at home and gain the fitness levels of a racing grinder - without having to miss out on the element of water!



- 1 Performance Monitor with touchscreen: swivels to and can be used from either side
- 2 Can be used with or without the seat, which can be hung into 3 different positions on either side
- 3 The handles can be set at different heights: the smaller the rotation, the higher the intensity
- 4 Wide, curved base frame is ideal for wheelchair users

Technical Details

- water for smart, adjustment-free resistance
- max. 20 l water
- weight without water approx. 50 kg

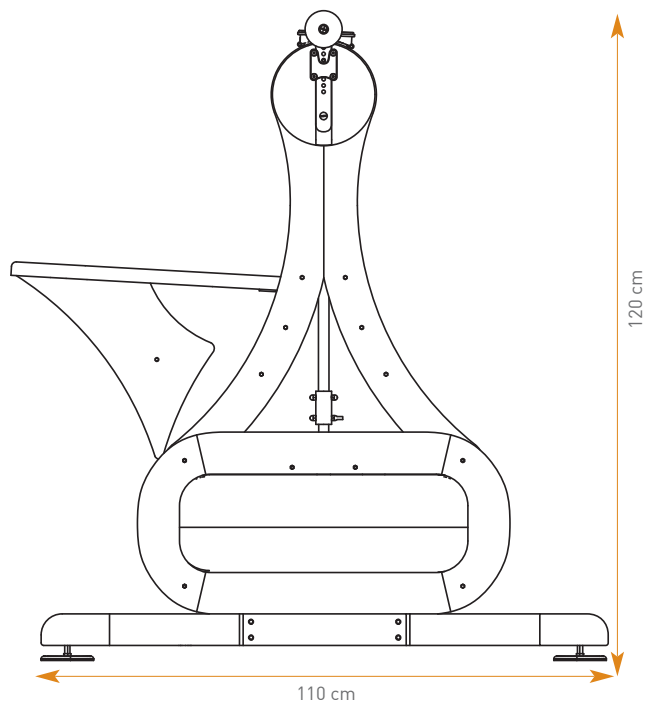
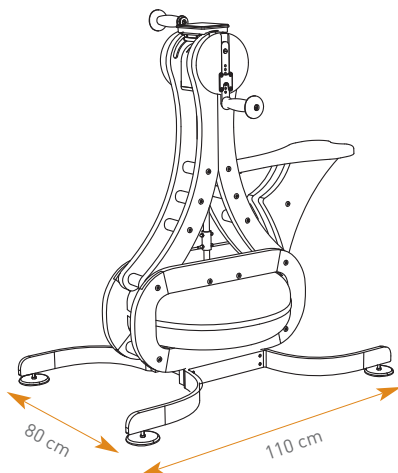

WaterGrinder

Strength / Endurance

Stationary cycles, elliptical trainers and treadmills are highly effective cardio machines, which, however, mainly work the lower body. Cardio workouts also include a muscular, toning component, yet there is a clear deficit in upper body training.

The WaterGrinder compensates this deficit by providing you with a full upper body workout, including arms, shoulders, chest, abs and all back musculature. Your upper body joints and spine enjoy all the right movement and strain stimulus necessary to maintain elasticity and resilience.

Our legs are made to sustain a continuous work throughout the day, making it more challenging to effectively stimulate these muscles. Our arms, however, are mostly engaged for shorter spurts of strain. The WaterGrinder guarantees rapid muscle fatigue through short and highly efficient workout sessions, conditioning strength and endurance simultaneously.

When exercising on the WaterGrinder, the upper body is in upright position: back and ab muscles are engaged and active - supporting muscle groups are directly stimulated, guaranteeing effective muscle development.



■ Dynamically trained muscle system
 ■ Statically trained muscle system



WaterGrinder

Model Overview / Price Information



Ash



Club



Oak



Cherry



Walnut

Models

Models	Order-No.
Ash	14100
Club	14101
Oak	14104
Cherry	14102
Walnut	14103

Technical Details

Height:	120 cm
Length:	110 cm
Width:	80 cm
Weight:	50,0 kg (without water)

Includes performance monitor.





SwingBells

Free Weights / **Leather**



SwingBells

Design / Training

Free weights made of solid wood and hand-stitched genuine leather: pep up your day with NOHrD SwingBells!

NOHrD SwingBells are a modern variation of Kettlebells, known from CrossFit workouts. Original Kettlebells are solid, cannonball-shaped weights with a simple grip. The SwingBell shifts its center of gravity, due to its iron granule filling, extending the exercise motion beyond your arm. The result is a targeted stimulation of your connective tissue (fascia), joints and muscles, increasing overall performance and resilience.

Not just for sweeping, wide-range moves - these genuine leather free weights are the perfect combination to exercise on other equipment. SwingBell exercises can be just as effective as push-ups, pull-ups or squats, as your core is virtually always engaged. The result: efficient increase in strength, muscle mass and coordination. Even short exercise sessions will train the targeted areas intensively, while requiring minimal space.



- 1 Hand-stitched genuine leather with a solid wood grip
- 2 Ideal for training your fascia through extra stimuli from the SwingBells' ever-shifting pellets
- 3 Available in various kinds of wood and leather colors
- 4 Stack up to 8 weights on the SwingTower or hang the bells onto the SwingBoard for easy storage

Technical Details

- Available weights: 1, 2, 4, 6, 8 kg
- Hand-stitched genuine leather

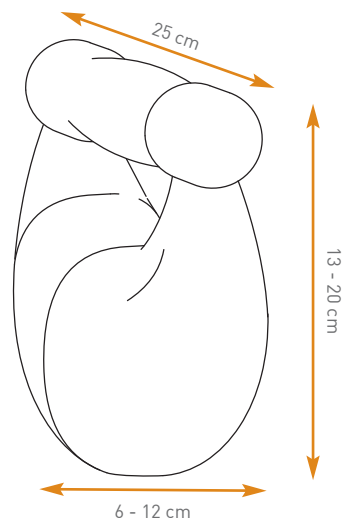



SwingBells free weights

Wood	Weight	Order-No.
Ash	1 kg	13100
Ash	2 kg	13104
Ash	4 kg	13108
Ash	6 kg	13112
Ash	8 kg	13116
Club	1 kg	13101
Club	2 kg	13105
Club	4 kg	13109
Club	6 kg	13113
Club	8 kg	13117
Oak	1 kg	13125
Oak	2 kg	13126
Oak	4 kg	13127
Oak	6 kg	13128
Oak	8 kg	13129

Wood	Weight	Order-No.
Cherry	1 kg	13102
Cherry	2 kg	13106
Cherry	4 kg	13110
Cherry	6 kg	13114
Cherry	8 kg	13118
Walnut	1 kg	13103
Walnut	2 kg	13107
Walnut	4 kg	13111
Walnut	6 kg	13115
Walnut	8 kg	13119

The Swing models Ash through Cherry are all made with black leather. For walnut, tan leather (natural) is used.

All SwingBells are packaged and delivered in a fitted cardboard box.

SwingBells

Model Overview / Price Information



Ash



Club



Oak



Cherry



Walnut



Ash



Club



Oak



Cherry



Walnut

Swing Tower Models

Models	Weights	Order-No.
Ash	1, 2, 4, 6 kg	13200
Ash	2, 4, 6, 8 kg	13201
Club	1, 2, 4, 6 kg	13203
Club	2, 4, 6, 8 kg	13204
Oak	1, 2, 4, 6 kg	13214
Oak	2, 4, 6, 8 kg	13215
Cherry	1, 2, 4, 6 kg	13206
Cherry	2, 4, 6, 8 kg	13207
Walnut	1, 2, 4, 6 kg	13209
Walnut	2, 4, 6, 8 kg	13210

Swing Boards Models

Models	Weights	Order-No.
Ash	1, 2, 4, 6 kg	13300
Ash	2, 4, 6, 8 kg	13301
Club	1, 2, 4, 6 kg	13303
Club	2, 4, 6, 8 kg	13304
Oak	1, 2, 4, 6 kg	13314
Oak	2, 4, 6, 8 kg	13315
Cherry	1, 2, 4, 6 kg	13306
Cherry	2, 4, 6, 8 kg	13307
Walnut	1, 2, 4, 6 kg	13309
Walnut	2, 4, 6, 8 kg	13310

Technical Details Tower

H x W x D: 87 cm x 15 cm x 15 cm
 Weight: 10 kg (without SwingBells)
 Base plate: 34 x 34 x 2,6 cm

Technical Details Board

H x W x D: 157 cm x 22 cm x 8,6 cm
 Weight: 5 kg (without SwingBells)



HaptikBall

Genuine leather / Hand-stitched

For squeezing, holding, lifting, throwing, swinging and playing. The NOHRD HaptikBall will work your hand, forearm and - with swinging exercise- your connective tissue. Even the simplest exercises are highly effective.

Ideal for strengthening, coordination, stress relief, fascia stimulation and balance training. Strengthen your hand and forearm muscles and increase circulation. Squeezing and releasing your hand will strengthen fingers, hands and forearm, while reducing stress levels. Handling and playing with the HaptikBall is both calming and fun!

Made of genuine leather and fully hand-stitched, the NOHRD HaptikBall is a true eye-catcher, with an iron granular filling rendering the HaptikBall its malleability and easy grip.

Each HaptikBall is oiled with beeswax for protection against sweat and moisture.



- 1 The HaptikBall's interior is filled with iron pellets
- 2 For holding, squeezing, lifting, throwing, swinging or just simply playing
- 3 The HaptikBall is packaged in a fitted cardboard box
- 4 Made in Germany: hand-stitched genuine leather, treated with beeswax for durability



HaptikBall Models	Order-No.
300 g	17100
650 g	17103
1250 g	17101
2100 g	17102

Technical Details

Weights: 300 g, 650 g, 1250 g, 2100 g
 Diameter 300 g: approx. 6 cm
 Diameter 650 g: approx. 7 cm
 Diameter 1250 g: approx. 8 cm
 Diameter 2100 g: approx. 10 cm

The HaptikBall is packaged in a fitted cardboard box.





WallBars

Wall Bars / **With Overhead Foldout**



WallBars

Wall Bars / **A Classic**

NOHrD WallBars, one of the most classic pieces of fitness equipment for multi-functional exercise, features a unique overhead foldout to expand your workout possibilities.

Ideal for hanging or pull-up exercise, the foldout arm clicks into its opened position, providing the necessary stability and room for hanging and swinging exercise. Elegant, sturdy and strong, the WallBars is the perfect allrounder and space-saver combined: our CombiTrainer, exercise bench and Multi-Adapter can be placed directly onto the bars for easy storage.

The WallBars is ideal for all areas of fitness training, especially strength building, mobility and coordination exercise. Made of solid wood and featuring a durable cord for the foldout, the WallBars is optimal for any multi-functional workout.

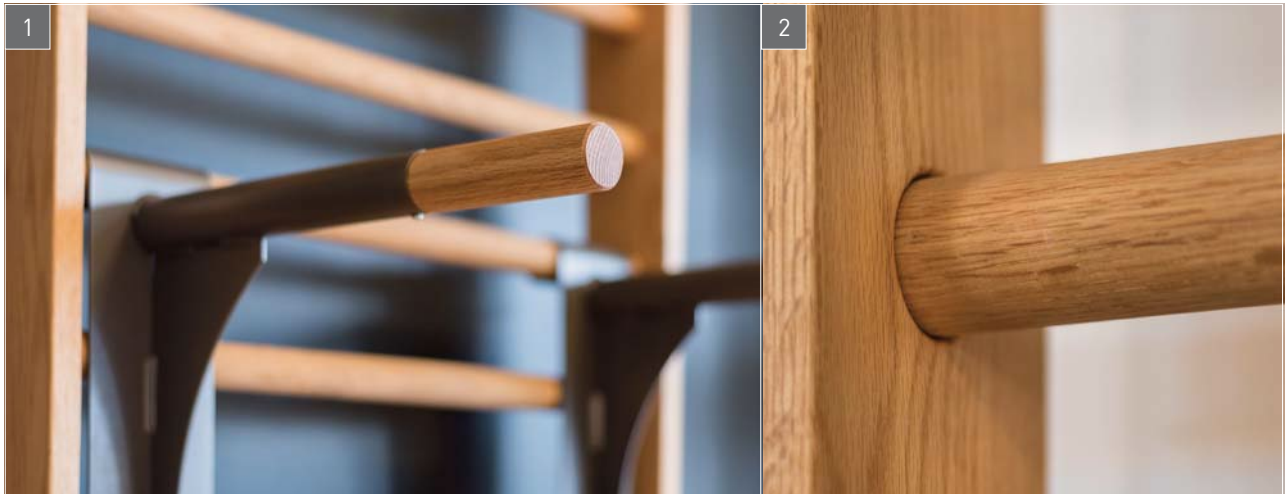

- 1 Various accessories expand your exercise range and provide new impulses
- 2 High grade materials used, available in 10 or 14 rungs
- 3 The integrated foldout arm opens and clicks into fixed position
- 4 WallBars exercise is a full, body weight resistance workout

Technical Details

- Measurements (closed): 230 cm x 79 cm x 13 cm
- Weight 10 / 14 bars: 19 kg / 21 kg
- Space between bars: 9,9 cm - 17,7 cm
- Max. weight load: approx. 120 kg

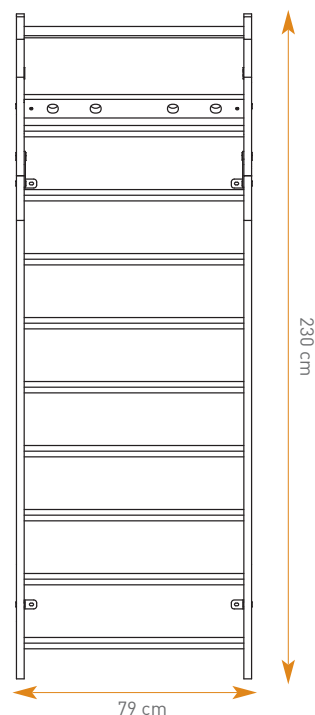

WallBars

CombiTrainer / Full Body Exercise

Exercise with body weight resistance, in sitting, prone or standing positions to work all muscle groups. The CombiTrainer cords run silently through the ball bearing mounted wheels, while the gliding seat cushion is upholstered with a non-slip fabric for a safe hold. This accessory functions 100% on body weight resistance.



Models

Ash
Club
Oak
Cherry
Walnut

Order-No.

12230
12231
12232
12233
12234

Technical Details

Length: 190 cm
Width: 60 cm
Lying surface: 85 cm x 35 cm (L x W)

WallBars not included

WallBars

Multi-Adapter / Dual Function

One piece - dual function:

the Multi-Adapter WallBars extension provides multiple exercise possibilities based on a simple, straightforward design. Hung into the bars as a single or double support, this piece offers a whole range of exercise additions to your workout.

Double Support

Place the Multi-Adapter into the rungs with bars facing forward for further exercises such as pull-ups, hanging pull-ups, knee raises and ab crunches.

Single Support

Place the Multi-Adapter into the rungs with bars facing forward for further exercises such as pull-ups, hanging pull-ups, knee raises and ab crunches.



Models

Ash
Club
Oak
Cherry
Walnut

Order-No.

12200
12201
12218
12202
12203

Technical Details

Dimensions: approx. 70 cm x 50 cm x 34 cm
Weight: ca. 5,5 kg
Materials: Wood, metal

WallBars not included

WallBars

Modular / **Extendable**



SIDE ARM LOCKING MECHANISM

Used in place of existing side arm fixture. The side arm can be fastened shut, thanks to the knob, rendering the side arm full stability in closed position.

12240

LEATHER BENCH

Can be hung on any rung.
Measurements: 33 x 136
GL = Genuine Leather,
AL = Artificial Leather

Measurements: 136 cm x 33 cm.

EL Black	12220
KL Black	12221
EL Red	12222
KL Red	12223
EL Brown	12224
KL Brown	12225
EL Natural	12226
KL Natural	12227

WALLBARS EXTENSION

21.5 cm extension incl bar. Extension can be easily mounted to any WallBars. Available in ash, oak, cherry and walnut wood.

Ash	12212
Club	12214
Oak	12219
Cherry	12215
Walnut	12216

WallBars

Model Overview / Price Information



Ash



Club



Oak



Cherry



Walnut

Models	Bars	Order-No.
Ash	10	12103
Ash	14	12102
Club	10	12105
Club	14	12104
Oak	10	12111
Oak	14	12110
Cherry	10	12107
Cherry	14	12106
Walnut	10	12109
Walnut	14	12108

WeightWorkx
Fitness Station / **With Weights**







WeightWorkx

Weight Training / **With Exercise Bench**

The NOHrD WeightWorkx is manufactured in various solid wood, rendering this machine all the desired characteristics one expects from wood: sturdiness, pliability and durability.

The WeightWorkx Fitness Station delivers classic cable weight training in a high-end design and is available in our finest ash, oak, and walnut wood with a selection of upholstery leather. Choose a standing or sitting position for a wide variety of cable machine exercises.

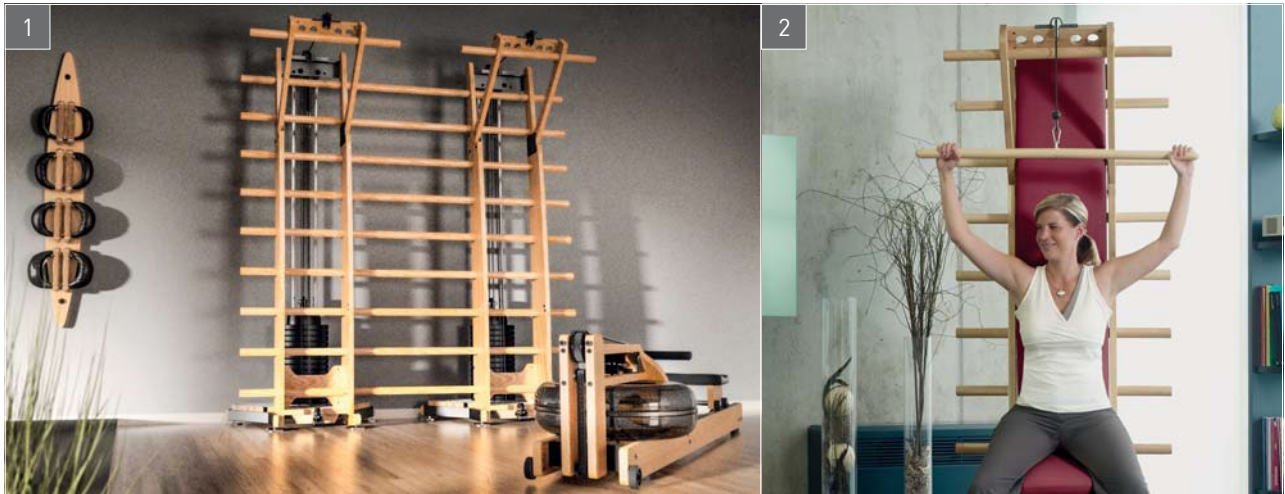

- 1 Available in DoubleWorkx model for tandem training
- 2 Integrated seat and exercise bench for extended workout
- 3 Each weight plate rubberized to minimize noise during exercise
- 4 Free-standing machine, no additional wall or ceiling fixture necessary

Technical Details

- Dimensions (foldout bar open): 89,5 cm x 228 cm x 93 cm
- Dimensions (foldout bar closed): 89,5 cm x 216 cm x 172 cm
- Weight: 135 kg
- 10 rungs

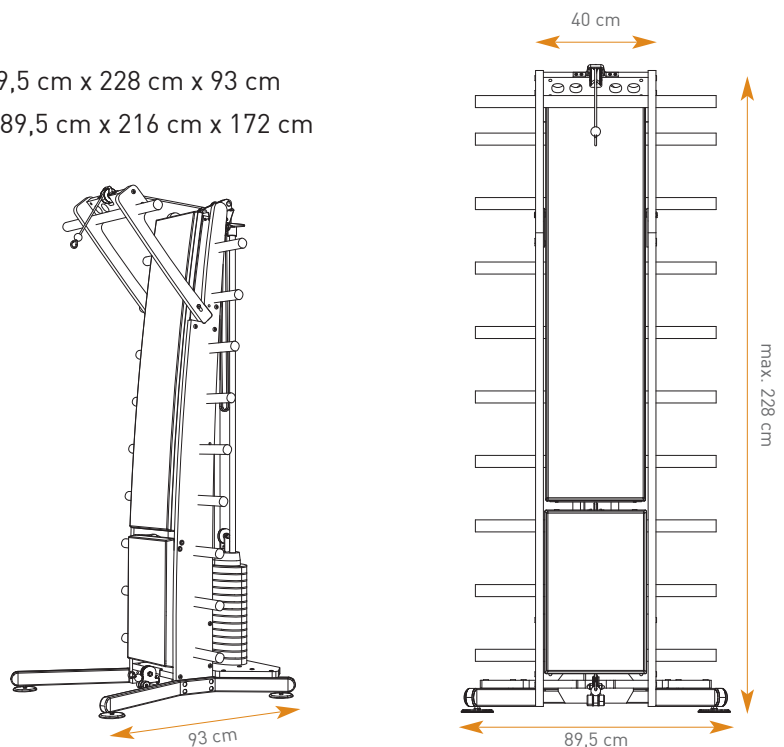

WeightWorkx

Details / Design

The rungs ensure safe holding during strength, coordination and stretching exercises. The four feet are individually adjustable for a strong stand on all floorings. The underside of the feet is rubberized for floor protection.

For cable training simply open the overhead arm. The top pulley is positioned horizontally, while the lower cable is led through a swiveling pulley, enabling smooth gliding exercise to the side.

The bench seat can be adjusted to two positions with an iron peg, which is inserted through the corresponding holes in the wooden frame. The exercise bench can be easily removed from the WaterWorkx frame and hung into four different positions. The feet are set at the push of a button and click into place.

Each WeightWorkx comes with an owner's manual featuring approx. 100 exercises, specifically pertaining to this fitness station. It can be hung into the rungs for easy viewing at eye-level.

Select exercises for individual muscle groups and/or combined- your arms, legs, abs and glutes will get toned according to your goals, while your back and other joints will gain increased resilience and mobility. The owner's manual contains a multitude of exercises for each body zone.



WeightWorkx

Model Overview / Price Information



Ash



Club



Oak



Walnut

DoubleWorkx Bench (optional)

Models	Leather	Order-No.
Ash	Artificial	11160
Ash	Genuine	11161
Club	Artificial	11162
Club	Genuine	11163
Oak	Artificial	11164
Oak	Genuine	11165
Walnut	Artificial	11166
Walnut	Genuine	11167

DoubleWorkx Seat (optional)

Models	Leather	Order-No.
Ash	Artificial	11168
Ash	Genuine	11169
Club	Artificial	11170
Club	Genuine	11171
Oak	Artificial	11172
Oak	Genuine	11173
Walnut	Artificial	11174
Walnut	Genuine	11175



WeightWorkx Models	Leather	Order-No.
Ash	Artificial	11107
Ash	Genuine	11106
Club	Artificial	11109
Club	Genuine	11108
Oak	Artificial	11153
Oak	Genuine	11152
Walnut	Artificial	11111
Walnut	Genuine	11110

DoubleWorkx Models	Order-No.
Ash	11113
Club	11115
Oak	11154
Walnut	11117

Accessories include: trapeze bar, long bar, short bar, footstrap, cord



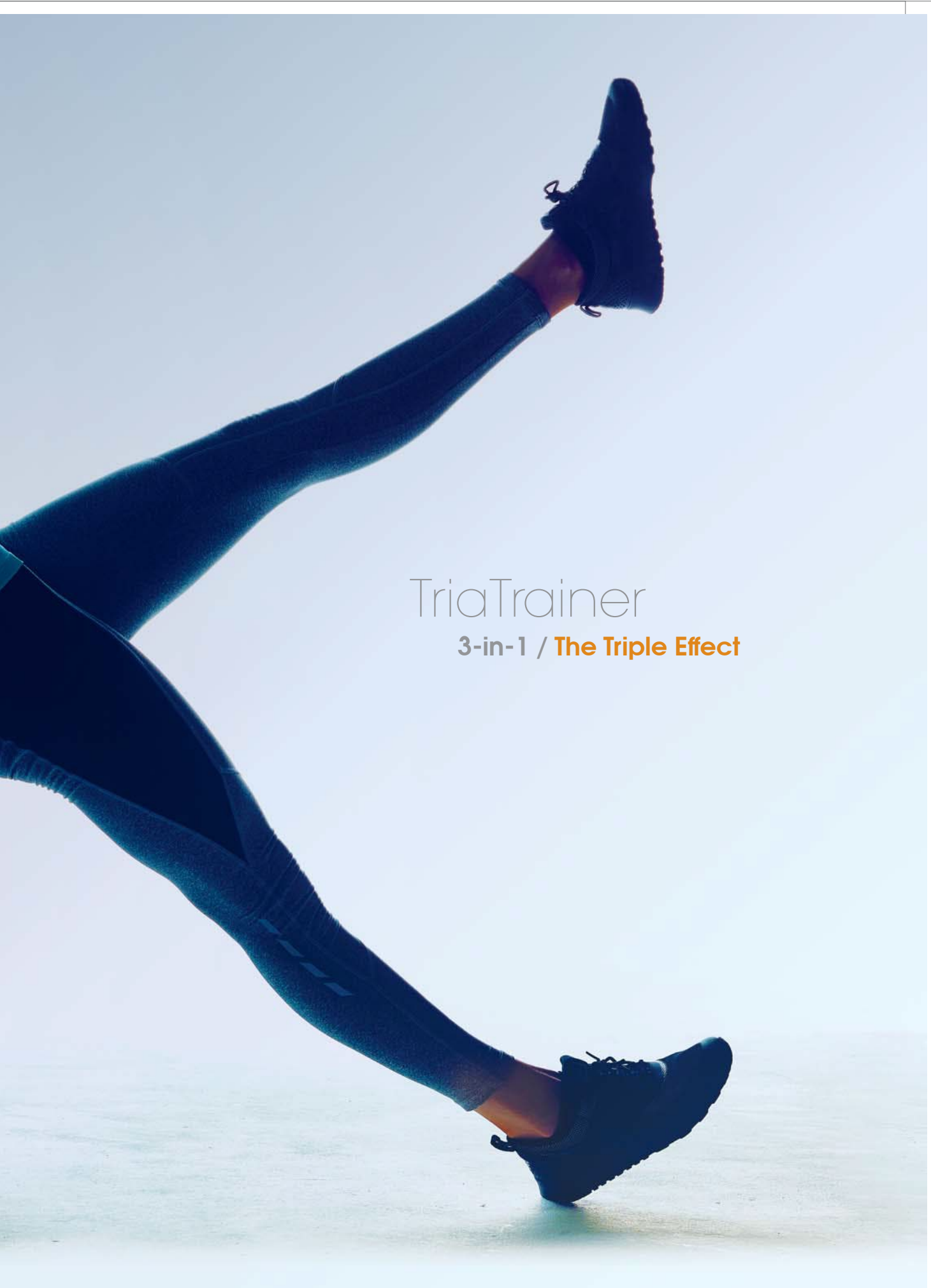

TriaTrainer

3-in-1 / **The Triple Effect**



TriaTrainer

3-in-1 / **The Abs, Back and Glutes Exercise Bench**

Small, handy and stylish: 3 functions in 1 space-saving piece. This workout bench functions as an abdominal and back trainer, as well as a weight bench. The versatile TriaTrainer combines elegance and athletic sturdiness in one exclusive piece of equipment, beautiful enough to fit right into your living room. A simple solution for a combination of uses!

In its fully folded up position, the TriaTrainer is a classic ab trainer. The adjustable footrest and upholstered bench enable efficient training in the smallest of spaces. Folded up, the exercise bench requires less than 1 sq meter space. Opening the TriaTrainer up into its mid-position, the bench easily converts into a back and glutes bench.

In its fully extended position the TriaTrainer serves as a weight bench. Perfect for classic bench press exercise, be sure to take advantage of the TriaTrainer's full potential.



- 1 Comes in various kinds of wood and leather - the TriaTrainer blends into all interiors
- 2 Make your own combination - the TriaTrainer compliments your workout on all other NOHRD exercise equipment
- 3 The footrest can be adjusted into 10 different settings - optimal for all exercise positions
- 4 The TriaTrainer cuts a fine figure as a classic weight bench

Technical Details

- Dim. closed (l x w x h): 90 cm x 35 cm x 55 cm
- Dim. opened (l x w x h): 140 cm x 35 cm x 44 cm
- Weight: 14 kg
- Max. weight load: 150 kg

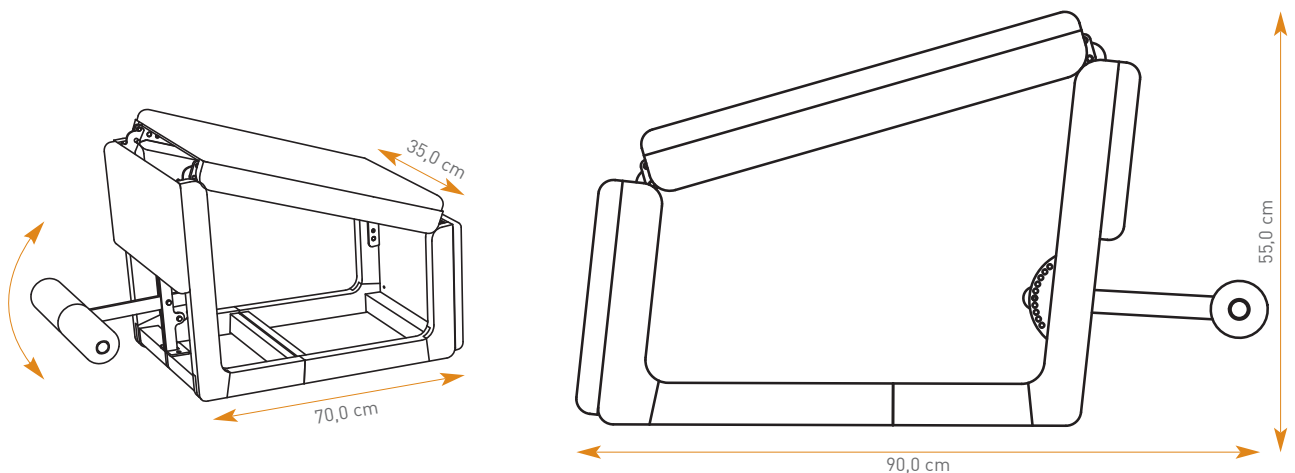



Ab Trainer



Back Trainer



Weight Bench

TriaTrainer

Exercise Bench / **Versatility**



Strong abdominal muscles are not only considered attractive but are also recommended from a health point of view: a trained core improves and stabilizes posture, and will prevent back pain.

An abdominal trainer is the ideal piece of exercise equipment: ab training is challenging and effective for all levels of fitness.

The TriaTrainer's closed standard position is perfect for ab training, on its own or in combination with other NOHRD equipment. Extending the workout range with our SwingBells, for instance, will work your shoulders and triceps.

Throughout the day, your back is subject to a variety of strain, from heavy work, to long hours of sitting and bad posture. Targeted back training is recommendable to avoid pain and damage. The TriaTrainer's mid-position ideal: perform a wide variety of targeted exercise to build spinal strength for your back and glutes.

In its fully extended position, the TriaTrainer is the classic bench press and free-weight bench, ideal for dumbbell and barbell training. The TriaTrainer does not come with a weight rack, so that a workout with free weights is more recommendable.

Use the weight bench position for a wide variety of multi-functional workouts. Muscle toning, for instance, can be enhanced by the slanted position of the bench. The fine leather upholstery ensures safe and comfortable support throughout your exercise session.



TriaTrainer

Model Overview / Price Information



Ash



Club



Oak



Cherry



Walnut

TriaTrainer Models	Leather	Order No.
Ash	Artificial	19100
Ash	Genuine	19101
Club	Artificial	19102
Club	Genuine	19103
Oak	Artificial	19104
Oak	Genuine	19105
Cherry	Artificial	19106
Cherry	Genuine	19107
Walnut	Artificial	19108
Walnut	Genuine	19109
Walnut	Genuine natural	19121



HedgeHock

Wooden Stool / **49 Comfortable Blocks**

A structured, clear and geometrical exterior counterbalances a flexible, moveable interior: the HedgeHock creates a harmony of dynamic and static equilibrium.

Your body will shape its own mold in the wooden block surface, enabling a true ergonomic sitting position. It defies logic to think that natural wood can be comfortable- the HedgeHock is, however, a unique sitting experience!

The 49 solid wood blocks are individually spring suspended within the outer wood cube.

The HedgeHock is a true interior design highlight, sure to attract attention in the home, office, hotel, waiting room or any other sitting area.

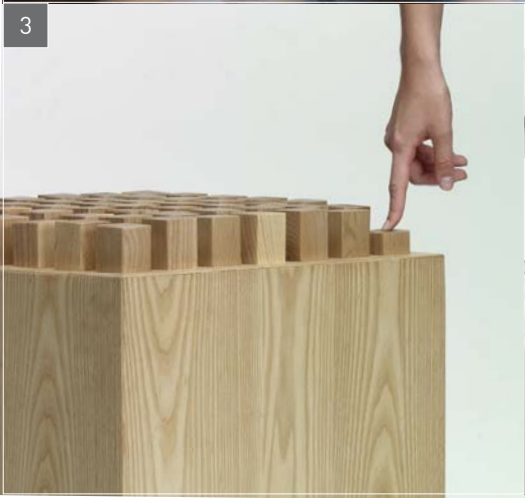

- 1 Unique sitting experience with a distinctive design
- 2 Available in various kinds of wood - individual seat blocks are made of solid wood
- 3 49 individually spring suspended seat blocks move and conform to any user
- 4 Suitable for all sitting and waiting areas – a true eye-catcher

Technical Details

- With bottom wheels for easy manoeuvring
- 49 seat blocks made of solid wood - individually spring suspended
- Dimensions: 45 x 45 x 45 cm



HedgeHock Models	Order-No.
Ash	16100
Club	16102
Oak	16112
Cherry	16104
Walnut	16106



Eau-Me Board

Balance Board / **Balance on Water**

A new kind of balance board - the patented combination of classic balance training with the added element of water for challenge. Balance boards are suitable for all ages. Regular use will enhance fitness and balance without strain to your joints - in the home, office or fitness studio.

Simply put, the Eau-Me board is all about balance, constantly attempting to throw you off kilter with its rounded, unstable base. Your body is challenged whenever the board leans to one side. The counter-balancing moves you must perform are made intuitively. During this exercise, the body learns to translate the constant impulses and stimuli it receives, correcting the imbalance.

Eau-Me Board

With Water / Find Your Balance



Ash



Club



Oak



Cherry



Walnut

Eau-Me Board

Models Order-No.

Ash	21100
Club	21101
Oak	21104
Cherry	21102
Walnut	21103

Black	21105
White*	21114
Grey*	21115

Material: real wood veneer multiplex panels
*HPL laminated panels

Technical Details

Dimensions: ø64 cm x 18 cm
Weight (without water): 7,5 kg
Max. weight load: 250 kg



NOHrD Wall

Fitness Wall / **Module System**

The NOHrD wall was designed as a complete fitness solution for the home studio, hotels for an exclusive in-room workout or personal training sessions.

The fitness wall can be configured in up to 5 freely combinable modules for high intensity interval training, as well as for a combination of different functional workouts. The result is highly effective training in the smallest of spaces.

All elements of the NOHrD Wall are the result of high-quality materials and technical know-how, perfectly designed right down to the smallest detail.

The virtual coach is an interactive program for highly effective workouts which can be operated via the touchscreen in the main component of the NOHrD Wall. With the virtual training system, users can choose between pre-designed interval workouts, functional training sessions or short/long exercise sequences - all with varying intensity. The user determines the length and then main focus of the workout.

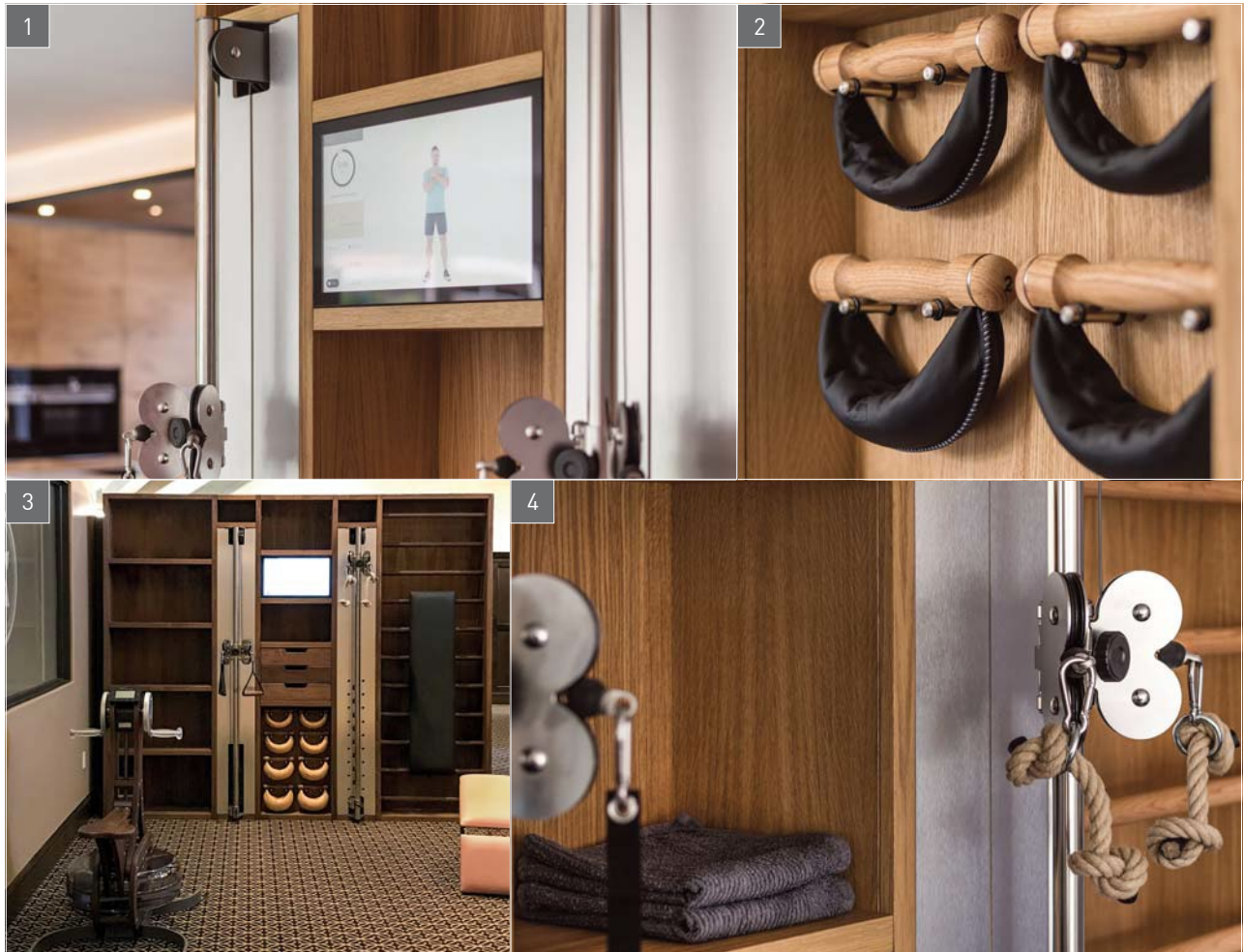

- 1 The virtual coach leads you through your workout. Exercises are featured in video for assistance
- 2 SwingBells complete the exercise program and can be hung into the NOHRD Wall for easy storage
- 3 The complete NOHRD Wall consists of a main unit, wall bars and the shelf module
- 4 Enjoy an effective full-body workout with cable weight and water training, as well as wall bars for an extended exercise range

Technical Details

- Modular system
- Freely combinable
- Minibar and drawers optional
- Max. height: 240 cm
- Min. height: 216 cm



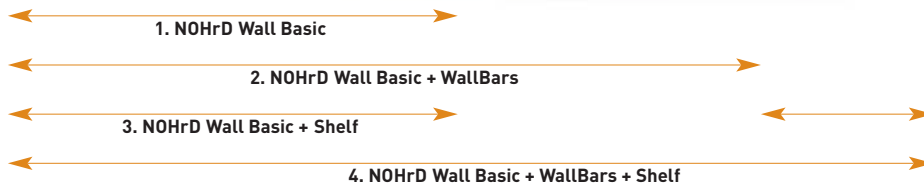

1. NOHrD Wall Basic*

Models	Order-No.
Ash	20310
Club	20320
Oak	20300
Cherry	20330
Walnut	20340

2. NOHrD Wall Basic + WallBars

Ash	20311
Club	20321
Oak	20301
Cherry	20331
Walnut	20341

3. NOHrD Wall Basic + Shelf

Ash	20312
Club	20322
Oak	20302
Cherry	20332
Walnut	20342

4. NOHrD Wall Basic + WallBars + Shelf

Models	Order-No.
Ash	20313
Club	20323
Oak	20303
Cherry	20333
Walnut	20343

NOHrD Wall Accessories

Minibar	20200
Drawer	20201

*Basic:
2 x cables, monitor, SwingBells (2, 4, 6, 8 kg),
extension handles, cords
Minibar and drawers optional

Min. height: 216 cm
Max. height: 240 cm
WallBars width: min. 50 cm, max. 80 cm
Shelf width: up to 80 cm

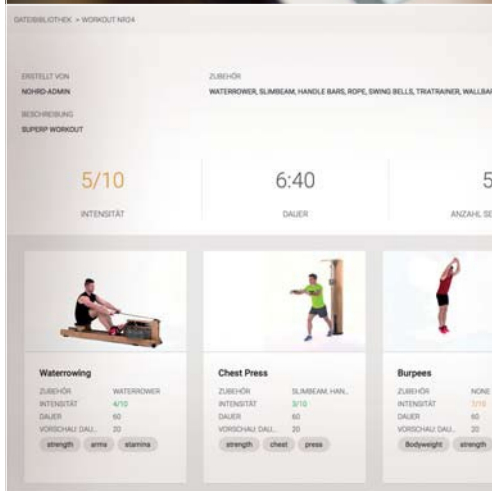
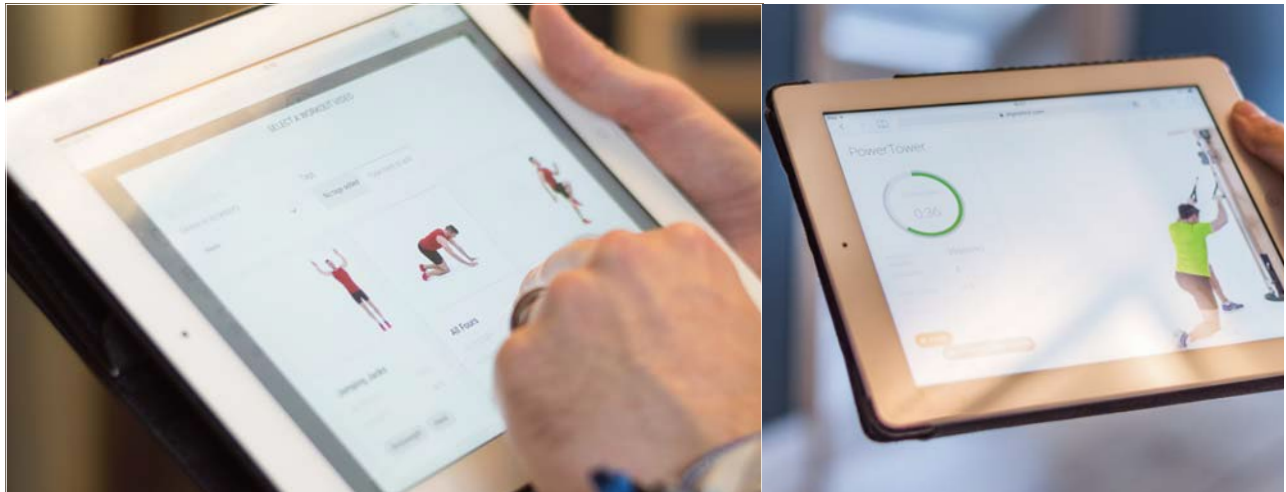

My-NOHRD



Improve your level of fitness! Take advantage of My-NOHRD for creating, sharing and customizing your workouts from more than 300 exercise videos.

The My-NOHRD platform is browser-based and available on all terminal devices. No need for an app, your personalized training sessions can be accessed on your computer, smartphone or tablet. Benefit from all of your NOHRD equipment's functions and configure your own workout in just a few clicks – tailor made to meet your demands, including stretching and warm-up segments.

Each exercise is demonstrated by the virtual coach on video, featuring helpful information pertaining to the selected muscle group, as well as to the level of intensity.

Certified coaches are available on My-NOHRD, as a fee-based option, to assist and provide customers with personalized training sessions, tailored to their specific needs and requirements. Communication takes place via chat feature.



SPRINTBOK



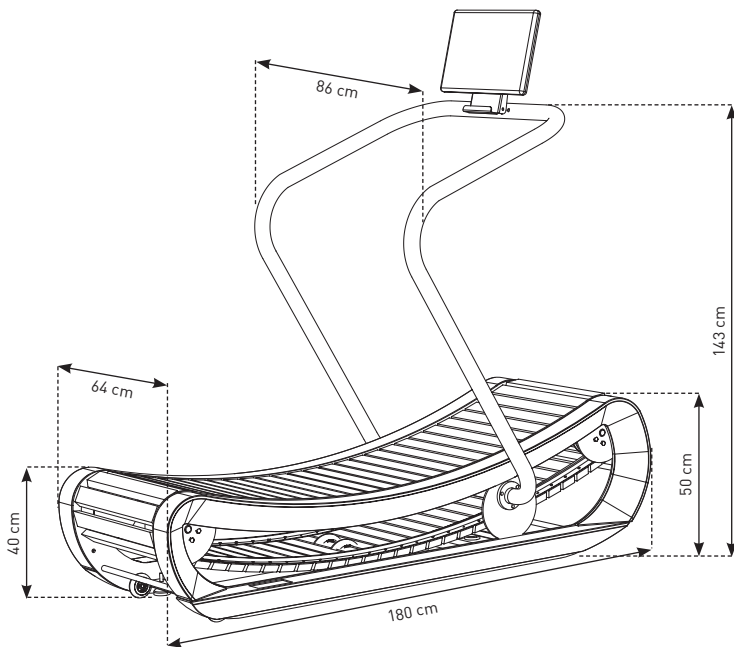

H: 175 cm
L: 180 cm
B: 86 cm



160 kg



1 x



160 kg

ELASKO



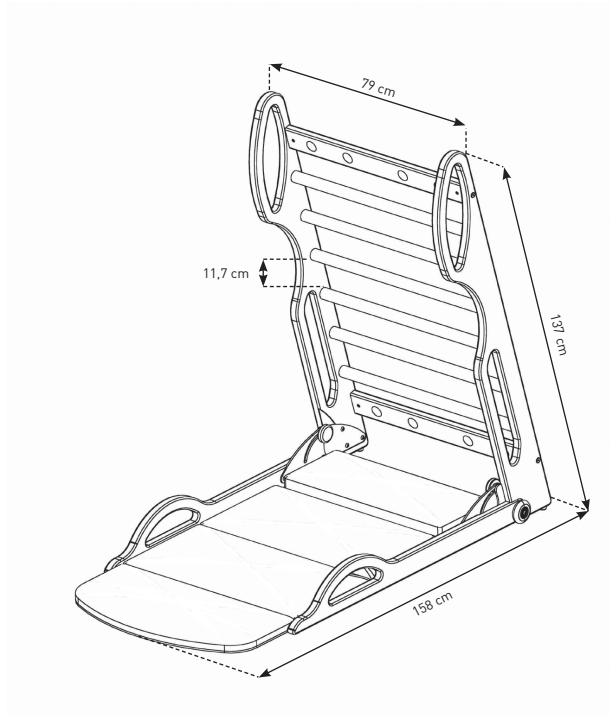

	L: 158 cm B: 79 cm H: 137 cm		40 kg
	1 x		120 kg



ADW SPORTS

SPORTS & ENTERTAINMENT DIVISION OF
ADMIRALWORLD GENERAL TRADING LLC

EXCLUSIVE DISTRIBUTOR OF:



TEQBALL
WORLD IS CURVED

STIL-FIT^{INT.}

IMPAGIA[®]

RILEY[®]
ENGLAND



OUR ADDRESS:

ADMIRAL WORLD General Trading LLC P.O Box 112661 Str.8
Showroom 46, Al Quoz 1, Dubai, United Arab Emirates

Call Us:

M: +971 50 865 6575

For Sales Enquiries:

sales@admiralworld.com



Follow us
[admiralworldsports](https://www.instagram.com/admiralworldsports)

www.adw-sports.store