

-OWNER'S MANUAL-

Every customer purchasing a Candock product from Candock Inc. or one of its authorized representatives and distributors should activate the Manufacturer's warranty via Candock's online warranty activation system.

Online warranty activation: <http://candock.com/about-us/support-and-warranty/register-product/>

Créer le	2020-11-30	Approbation	
Fichier	Owners manual	Révision	02

⊙ BASIC PRODUCTS 5

HOW CANDOCK WORKS.....	5
LAYERS AND TABS.....	6
CUBES (REGULAR AND LOW PROFILE)	7
EDGE CUBES (REGULAR AND CORNER).....	9
CORNER CUBE.....	11
CANDOCK SERVICE CHANNEL.....	13
SERVICE CUBE BASE	14
COVER OPTIONS.....	14
CONNECTING PIN	17
SLIDING NUT	19
BOLT FOR CUBE	20
NUT	21
SPACER.....	21

⊙ DOCK ACCESSORIES 22

BUMPER.....	22
VERTICAL BUMPER	23
CLEAT	24
FOLDING CLEAT ON CONNECTING PIN.....	25
H.D. BOLLARD CLEAT	26
MODULAR RAILING SYSTEM.....	27
HANDRAIL POSTS AND RAILINGS (SURFACE AND PERIPHERAL).....	28
LED LIGHT SYSTEM.....	31
LED LIGHTS – CONTROL UNITS - COVERS.....	32
OUTBOARD ENGINE MOUNT.....	35
SWIM LADDER	36
BENCH.....	37
REVOLVING AND FOLDING SEAT	38
STORAGE CUBE	39
MOORING WHIPS SUPPORT	40
MODULAR KAYAK RACKS (SINGLE AND DOUBLE)	41
DOUBLE LAYER ROD KIT.....	42

⊙ ANCHORING PRODUCTS..... 43

PILINGS INTRODUCTION.....	43
POST CUBE + 2 ^{7/8"} X 0.120 GALVANIZED STEEL PILE + 3" PVC SLEEVE AND CAP	44
1 ^{11/16"} X 0.10 GALVANIZED STEEL PILE AND CAP	48
ADJUSTABLE PILE SUPPORT 2-7/8" - GALVANIZED	49
HDPE PILE GUIDE FOR 2 ^{7/8"} STEEL PILE.....	50
"Z" BRACKET FOR 2 ^{7/8"} STEEL PILE (16" AND 6")	51

PILE SUPPORT FOR 1 ^{11/16} " STEEL PILE.....	52
OTHER PILING ATTACHMENT OPTIONS.....	54
ADJUSTABLE PILE GUIDE FOR EXISTING PILES OF 15cm TO 38cm O/D (6" TO 15")	54
PILE GLIDE ADAPTOR (CAROLINA WATERWORKS - ALUMINUM OR GALVANIZED STEEL).....	55
UNDERWATER ANCHORING POINTS WITH ANCHOR LINES INTRODUCTION	56
ANCHOR PLATE FOR CHAIN	58
CONNECTING PIN WITH PIVOTING ANCHOR PLATE FOR CHAIN	59
CONNECTING PIN WITH ANCHOR RING FOR CHAIN (CONCRETE FILLED).....	60
"HOT DIPPED" GALVANIZED STEEL CHAINS	61
SHACKLES.....	61
ELASTIC ANCHORING CABLES (TMS)	62
MISCELLANEOUS ANCHORING TECHNIQUES	64
WALL ANCHORS AND EXTENSION PLATE FOR WALL ANCHORS	64
SWIVEL ANCHOR CHANNEL FOR JETROLL	66
SLIDING ANCHOR H-BEAM	67
⊙ JETSLIDE DRY-DOCK SYSTEM.....	69
JETSLIDE SYSTEM BASIC CONCEPTS.....	69
JETSLIDE	70
OPERATING A WATER-CRAFT WITH THE JETSLIDE	72
STIFFENING BEAMS	73
"V" PLATE.....	74
EXTENSION PLATES (1, 2, AND 3 CUBES) AND BOLTS FOR JETSLIDE.....	75
.....	75
JETSLIDE BOAT WINCHES.....	76
JETSLIDE PWC WINCH.....	77
CONNECTING PIN WITH LOCK CHAIN.....	78
PWC JETSLIDE SYSTEM CONFIGURATION GUIDELINES	79
PWC JETSLIDE SYSTEM ANCHORING GUIDELINES.....	80
BOAT JETSLIDE SYSTEM CONFIGURATION GUIDELINES.....	82
⊙ JETROLL DRY-DOCK SYSTEM.....	83
JETROLL SYSTEM BASIC CONCEPTS	83
JETROLL (BOW-STOP, HOLE CAPS, AND WHEELS).....	84
LINK-KITS.....	87
EXTENDED CONNECTING PINS FOR JETROLL	90
PWC JETROLL SYSTEM CONFIGURATION GUIDELINES.....	91
PWC JETROLL SYSTEM ANCHORING GUIDELINES	92
⊙ GANGWAYS	93
GANGWAYS BASIC CONCEPTS AND CONFIGURATION GUIDELINES	93
GANGWAY FRAMES (TRADITIONNAL AND MODULAR)	94

GANGWAY SPECIFICATION CHART	95
RAILINGS (TRADITIONNAL AND MODULAR).....	96
DEPARTURE ANGLES (TRADITIONNAL AND MODULAR)	97
MODULAR HINGED LINK KITS.....	98
SHORE-END PILE BRACKETS (WELDED AND MODULAR).....	99
CANDOCK HINGES	100
SLIDERS (FOR WELDED AND MODULAR FRAMES)	101
ROLLERS.....	102
GANGWAY RECEPTION PLATES	103
TRANSIT PLATES (WELDED AND MODULAR FRAMES)	104
DECKINGS.....	105
⊙ TOOLS.....	106
KEY FOR CONNECTING PINS	106
KEY FOR NUTS.....	106
PILING DRIVER, PILING BULL AND PILING LEVER.....	107
TOOLS FOR CANDOCK MODULAR RAILINGS	108

◎ BASIC PRODUCTS

HOW CANDOCK WORKS

Before starting, here are some basic principles about the Candock Modular floating system that apply throughout the instruction manual. Our system relies on a simple yet proven coupling system to attach all its components.

Candock parts are secured together using a "Nut and Bolt/Screw" system. Depending on the specifications, geometries, application, and options required for your project, the below principles and concepts apply in different forms. The coupling hardware may vary depending on the location of the assembly point. Usually, the CONNECTING PIN and SLIDING NUT are used for coupling modules on the interior of the system. On the other hand, the BOLT FOR CUBE and NUT are used for coupling modules on the outskirts of the system.

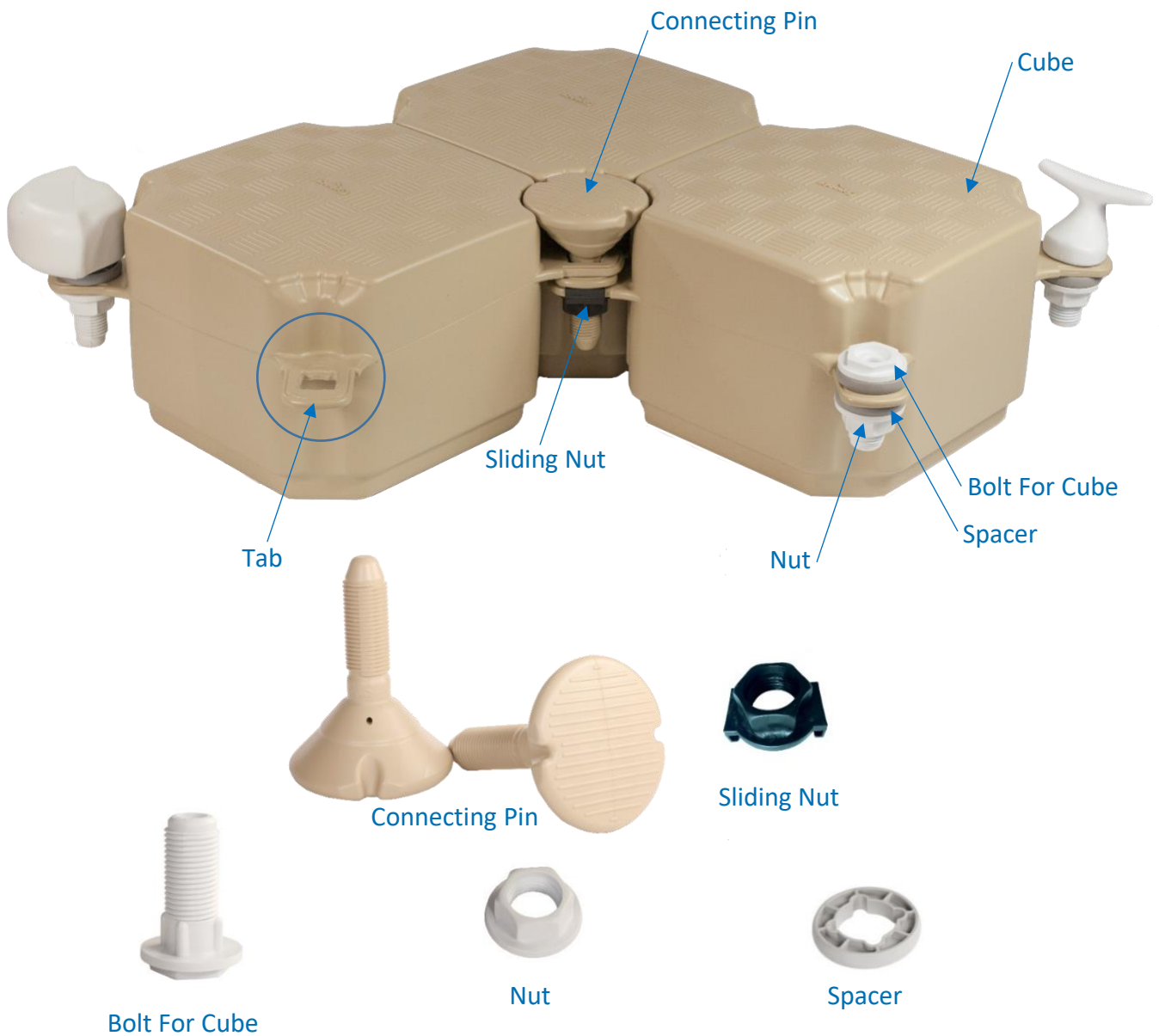

LAYERS AND TABS

The "Nut and Bolt/Screw" coupling system requires every tab to be coupled at a designated coupling point and must be overlapped adequately for the system to work. The images and diagrams below demonstrate which "layer" each tab of our different modules is using.

The lowest tab available in a designated assembly point holds the SLIDING NUT. The additional tabs of the cubes will be positioned in superimposed layers. If a gap (missing tab) is present as you overlap the tabs, the void is filled by a SPACER until you have reached the highest available tab in your assembly.

In the below image, layers #2, #3, and #4 are occupied by tabs 2, 3, and 4. On the lowest tab available in the assembly*, a SLIDING NUT is inserted on the tab to allow for the CONNECTING PIN's "male" threads to have traction in the "female" threads of the SLIDING NUT.

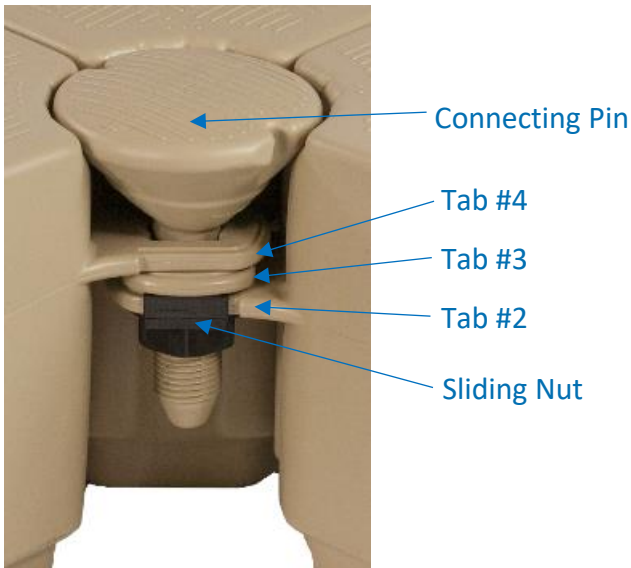

*Layer 1 (tab #1) is missing in the featured assembly to allow for the assembly's good viewpoint.

TAB POSITIONS

The basic components of the Candock system are using eight (8) different layers (tabs). Starting from the lowest tab, the sequence is as follows: -1, 0, 1, 2, 3, 4, 5, and 6. The regular CUBE uses tabs #1, #2, #3 and #4. The other components (CORNER CUBE and EDGE CUBES) are using tabs #-1, #0, #5, and #6. Throughout our manual, we use the below diagram to explain which layers (tabs) is utilized for each system/product.

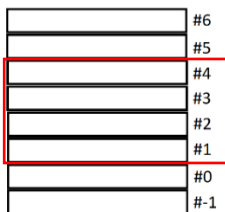

Diagram demonstrating which tabs are used.

In this case, the featured product/module utilizes tabs #1, #2, #3 and #4.

CUBES (REGULAR AND LOW PROFILE)



Regular



Low-profile

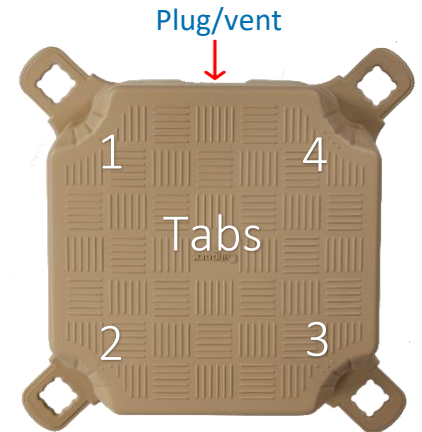

USEFUL LINKS AND RESOURCES:

[YouTube](#)

[Website](#)

TAB POSITIONS

	#6
	#5
	#4
	#3
	#2
	#1
	#0
	#-1

SPECIFICATIONS

Material/Composition: High-density polyethylene resin

Available colors: Beige, Gray

Surface: Anti-skid

Dimensions: L x W: 48 cm (19") x 48 cm (19") H: 36 cm (14")

Dimensions (low profile cube): L x W: 48 cm (19") x 48 cm (19") H: 23 cm (9")

Maximal Floating capacity Regular cube: 68 kg (150 lbs.) per cube

Maximal Floating capacity – Regular cube - per square meter (sq. ft): 272 kg per sq. m. (60 lbs. per sq. ft.)

Maximal Floating capacity Low profile cube: 50 kg (110 lbs.) per cube

Maximal Floating capacity – Low profile cube - per square meter (sq. ft): 210 kg per sq. m. (44 lbs. per sq. ft.)

Suggested working load – Regular cube - per square meter (sq. ft): 90 kg per sq. m. (20 lbs. per sq. ft.)

Weight: Cube: 5.5 kg (12 lbs.) / Low profile cube: 5 kg (11 lbs.)

Needed tools: G2 key for pin, Key for nut

SKU NUMBERS

G2 CUBE BEIGE: C01-000002

G2 CUBE GRAY: C01-000001

LOW PROFILE G2 CUBE BEIGE: C01-000007

LOW PROFILE G2 CUBE GRAY: C01-000008

TERMINOLOGY

TABS: Prominent grooved parts of the cube, located at different heights on each of the four (4) corners of the "cube" (tab #1 to #4, #1 being the lowest and #4, the highest). These tabs are an integral part of the Candock system. When assemble in groups of 4, the cubes create a larger square. At the center of this square, four (4) different tabs overlap each other. These tabs form a single opening and are meant to be coupled with our SLIDING NUT and CONNECTING PIN to form a unique structure.

PLUGS: These watertight plugs are always found on the cube side between tab # 1 and # 4. These plugs, made of breathable material, act as pressure release valves preventing any cube deformation due to temperature changes and pressure variations. Furthermore, these plugs prevent any condensation inside the cube.

NOTE: Fully sealed plugs (no pressure release valve) are also available if the cubes should be submerged for extended periods.

ASSEMBLY PROCEDURE

PRIOR TO INSTALLATION

1-During the installation of a dock, always have the plugs oriented towards the shore. This orientation uses fewer SPACERS and improves the aesthetic of your dock. If your configuration is meant to go along the shoreline instead of offshore (parallel to shore instead of perpendicular), align plugs towards the shortest side of your dock.

2-Always make sure to regroup four (4) different tab heights to complete your assembly. Make sure they are in their pre-destined position and that none of these are wrongfully overlapping each other.

3-Preassemble the dock in larger sections directly on the ground. Before putting the dock in the water, prepare the missing units of CONNECTING PINS and SLIDING NUTS and position them on each section's corresponding side. This step helps you save time.

PROCEDURE:

- 1- Prepare all items and have them unboxed close to your "assembly" area (cubes, connecting pins, sliding nuts, spacers, and tools)
- 2- Insert a SLIDING NUT on the lowest tab available at each connecting point.
- 3- Position the sections next to each other and ensure that the tabs are overlapping correctly. Fill in any empty layers in-between the tabs with SPACERS
- 4- Insert the CONNECTING PINS in the tabs as you progress and manually engage the threads.
- 5-Once the sequence of cubes is connected, complete assembly by firmly tightening the CONNECTIN PINS.
- 6- Add BOLT FOR CUBE and NUT assemblies on the entire perimeter of your dock. If necessary, do not forget to fill the empty layers in-between the tabs with SPACERS.

TRICKS AND TIPS: THE SCISSOR TECHNIQUE

While assembling bigger sections on the water, proceed with the following steps:

- 1-Insert SLIDING NUTS at each coupling point.
- 2-Insert a CONNECTING PIN as shown on the diagram
- 3-Bring the two sections side by side while correctly overlapping each tab.
- 4- Insert CONNECTING PINS at each coupling point and tighten firmly.

This technique helps you assemble big sections with ease.

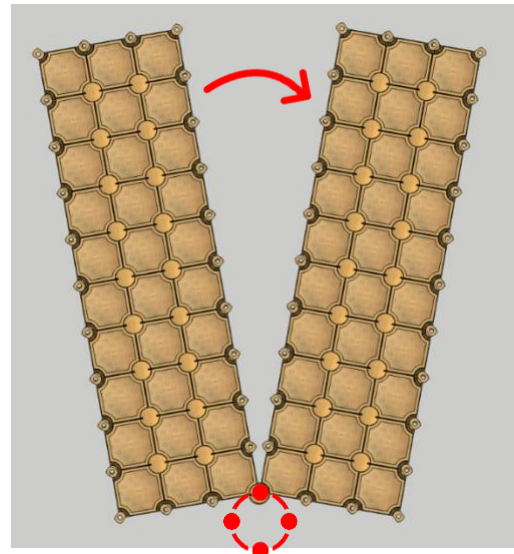

EDGE CUBES (REGULAR AND CORNER)

REGULAR



CORNER



USEFUL LINKS AND RESOURCES:

[Website](#)

[YouTube](#)

TAB POSITIONS

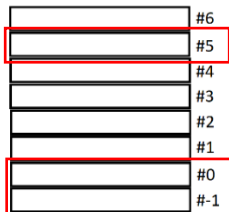

SPECIFICATIONS

Material/Composition: High-density polyethylene resin

Available colors: Beige and Gray

Surface: Anti-skid

Dimensions: Regular: L x W: 48 cm (19") x 24 cm (9^{1/2}") H: 23 cm (14")/ Corner: L x W: 24 cm (9^{1/2}") x 24 cm (9^{1/2}") H: 29 cm (11")

Floating capacity: Regular 30 kg (66 lbs.) per cube

Weight: Cube: 4 kg (9 lbs.)

Needed tools: G2 key for pin

SKU NUMBERS

EDGE CUBE BEIGE: C01-000013

EDGE CUBE GRAY: C01-000014

CORNER EDGE CUBE BEIGE: C01-000015

CORNER EDGE CUBE GRAY: C01-000016

TERMINOLOGY

EDGE CUBE: Still using our regular "nut and pin" system on tabs, which are now located at different heights on 2 of the corners of Candock's EDGE CUBE, are still an integral part of the Candock system. When added to our regular CUBES perimeter, the EDGE CUBES create a smoother and more aesthetic finish while eliminating any prominent pieces on the outskirts of your dock. The EDGE CUBE tabs are located at a lower position than the regular G2 cube's tabs (#1 to #4). Representing layers "negative 1" and "zero" (-1 being the lowest and -zero ("0") being just above), these always need to be positioned underneath the regular CUBE'S tabs.

CORNER EDGE CUBE: Again, using our regular "nut and pin" system on a single tab located on one corner of the CORNER EDGE CUBE. When added to our regular CUBES perimeter, the CORNER EDGE CUBE creates a smoother and more aesthetic finish on the outskirt corners of your dock while eliminating the prominent part sticking out of the structure (G2 cube tab). The CORNER EDGE CUBE tab is tab #5, which is the same one as the two (2) lower tabs of the CORNER CUBE.

ASSEMBLY PROCEDURE

IMPORTANT NOTIONS

- Any tab layer that presents no tab must be replaced by a SPACER, starting from the lowest tab available going upwards.
- A SLIDING NUT is required on the lowest tab available (either "0" or "-1").
- Make sure you work on dry land with a flat and uniform surface. Installing EDGE CUBES in the water is possible, but the task is more challenging and requires a minimum of 2 people to proceed.

SEQUENCE

- 1- Prepare all items and have them unboxed close to your "assembly" area (cubes, connecting pins, sliding nuts, spacers, and tools)
- 2- Insert a SLIDING NUT on the lowest tabs available at each connecting point.
- 3- Position the sections next to each other, alongside the regular G2 CUBES assembly, and ensure that the tabs are overlapping adequately.
- 4- Insert the CONNECTING PINS in the tabs as you progress and manually engage the threads.
- 5-Once the sequence of cubes is connected, complete assembly by firmly tightening the CONNECTIN PINS.



CORNER CUBE



TAB POSITIONS

#6
#5
#4
#3
#2
#1
#0
#-1

SPECIFICATIONS

Material/Composition: High-density polyethylene resin
Available colors: Beige and Gray
Surface: Anti-skid
Dimensions: L x W: 48 cm (19") x 48 cm (19") ÷ 2 H: 23 cm (9")
Weight: Cube: 4 kg (9 lbs.)
Needed tools: G2 key for pin, Key for nut

SKU NUMBERS

G2 CORNER CUBE BEIGE: C01-000011
G2 CORNER CUBE GRAY: C01-000012

TERMINOLOGY

TABS: Prominent grooved parts of the cube located at two (2) different heights on each of the three (3) corners of the CORNER CUBE (tabs 5 and 6). Two of those tabs are identical, namely tab #5. The 3rd one, being slightly higher (tab #6), features a bigger and beveled opening to accommodate the CONNECTING PIN'S neck's conical shape. These tabs are also an integral part of the Candock assembly system. Utilizing layers 5 and 6, the CORNER CUBE can be installed anywhere around a Candock dock without interfering with the regular CUBES tabs (1, 2, 3, and 4).

ASSEMBLY PROCEDURE

IMPORTANT NOTIONS

-Any tab/layer that presents no tab must be replaced by a SPACER, starting from the lowest tab available, going upwards.

INTERIOR CORNER CONFIGURATION: SLIDING NUTS and CONNECTING PINS are required at each connecting point.

EXTERIOR CORNER CONFIGURATION: (1x) SLIDING NUT and (1x) CONNECTING PIN is required for the "inside connecting point. (2x) BOLT FOR CUBE and (2x) NUTS are required for the 2 "outside" connecting points.

SEQUENCE

- 1- Prepare all items and have them unboxed close to your "assembly" area (corner cubes, connecting pins, sliding nuts, bolts for cube, white nuts, spacers, and tools)
- 2- Insert a SLIDING NUT on the lowest tabs available at each connecting point.
- 3- Position the CONER CUBE alongside the regular G2 CUBES assembly and ensure that the tabs are overlapping adequately.
- 4- Insert the CONNECTING PINS in the "inside" openings as you progress and manually engage the threads.
- 5-Insert all needed SPACERS on the "outside" connecting points.
- 5- Insert the BOLT FOR CUBE on the "outside" tabs as you progress.
- 6-Manually engage the NUTS on the BOLT FOR CUBE as you progress.
- 7-Once the cubes' sequence is connected, complete assembly by firmly tightening the CONNECTIN PINS and BOLT FOR CUBE/NUTS assemblies.

CANDOCK SERVICE CHANNEL

Before starting, here are some basic principles about the Candock service channel system. The service channel system abides by the same assembly concepts as our regular floating dock system while allowing many advantages. Consisting of a "2-piece" cube (the SERVICE CUBE BASE and the SERVICE CUBE COVER), multiple units' assembly allows marina service channels, outlets (freshwater outlets and electrical services) and our unique LED light system to be seamlessly integrated into our modular floating dock system.

As is the case with our regular system, all Candock parts are secured together using a "Nut and Bolt/Screw" system. Depending on the specification, geometries, application, and options required for your project, the same principles explained earlier apply. The coupling hardware may vary depending on the location of the assembly point. The CONNECTING PIN and SLIDING NUT are used for coupling modules inside the System's perimeter. On the other hand, the BOLT FOR CUBE and NUT are used for coupling modules on the outskirts of the system.

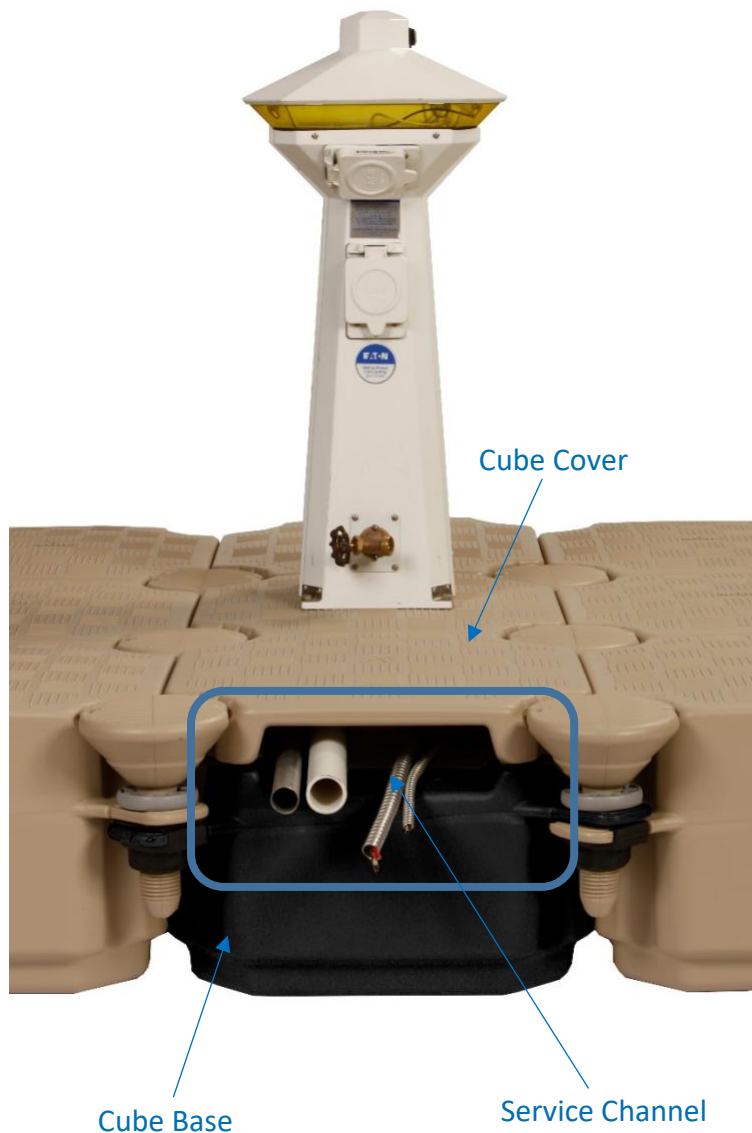

SERVICE CUBE BASE

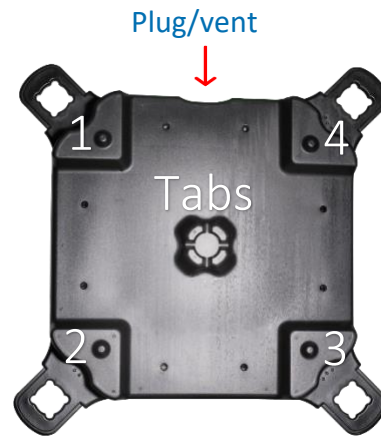

COVER OPTIONS



Tile, Gray or Beige

Tile LinQ, Gray or Beige



Translucent (used with
our LED light system)

USEFUL LINKS AND RESOURCES:

[Website](#)

TAB POSITIONS

	#6
	#5
	#4
	#3
	#2
	#1
	#0
	#-1

SPECIFICATIONS

Material/Composition: High-density polyethylene resin

Available color cube base: Black

Available colors cube cover: Beige, Gray, and translucent (**LED Light System**)

Surface: Anti-skid

Dimensions cube base: L x W: 48 cm (19") x 48 cm (19") H: 26.6 cm (10 ½")

Weight cube base: Cube: 5 kg (11 lbs.)

Dimensions cube cover: L x W: 48 cm (19") x 48 cm (19") H: 7.4 cm (2.9")

Weight cube cover: Cube: 1.65 kg (3.64lbs.)

Maximal conduits diameter: 45mm (1.75")

Needed tools: G2 key for pin, Key for nut.

SKU NUMBERS

G2 SERVICE CUBE BASE BLACK: C01-000003

REGULAR SERVICE COVER TILE BEIGE: C03-000016

REGULAR SERVICE COVER TILE GRAY: C03-000017

REGULAR SERVICE COVER TRANSLUCENT: C01-000010

LINQ SERVICE COVER TILE BEIGE: C03-000018

LINQ SERVICE COVER TILE GRAY: C03-000019

TERMINOLOGY

TABS: Prominent grooved parts of the cube, located at different heights on each of the four (4) corners of the "cube" (tab #1 to #4, #1 being the lowest and #4, the highest). These tabs are an integral part of the Candock system. When rallied in groups of 4, the cubes create a larger square. At the center of this square, four (4) different tabs overlap each other. These tabs form a single opening and are meant to be coupled with our SLIDING NUT and CONNECTING PIN to form a unique structure.

PLUGS: These watertight plugs are always found on the cube side between tab # 1 and # 4. These plugs, made of breathable material, act as pressure release valves preventing any cube deformation due to temperature or altitude. Furthermore, these plugs prevent any condensation inside the cube.

TILE COVER

The **TILE COVER** must be surrounded by other cubes (REGULAR CUBES, SERVICE CUBES, CORNER CUBES, OR EDGE CUBES) on all four (4) sides. The four (4) surrounding connecting pins, especially their "slanted necks," compress the cover onto the cube's base, making it a sturdy and robust assembly.

ASSEMBLY PROCEDURE

PRIOR TO INSTALLATION

1-During the installation of a dock, always have the plugs oriented towards the shore. This orientation uses fewer SPACERS and improves the aesthetic of your dock. If your configuration is meant to go along the shoreline instead of offshore (parallel to shore instead of perpendicular), align plugs towards the shortest side of your dock.

2-Always make sure to regroup four (4) different tab heights to complete your assembly. Make sure they are in their pre-destined position and that none of these are wrongfully overlapping each other.

3-Preassemble the dock in larger sections directly on the ground. When in the water, prepare the missing units of CONNECTING PINS and SLIDING NUTS and position them on each section's corresponding side. This step helps you save time.

NOTES:

-As the SERVICE CUBE is composed of 2 parts (base and cover), including the covers or not in your pre-assembly (i.e., "4-pack" of cubes) depends on the application, geometries, and the environment you are working in. Contact your local Distributor or Candock's head offices for more information and insight in this regard.

The below procedure, we include the covers on the cube bases in our assembly.

PROCEDURE:

- 1- Prepare all items and have them unboxed close to your "assembly" area (cube bases, cube covers, connecting pins, sliding nuts, spacers, and tools)
- 2- Insert a SLIDING NUT on the lowest tab available at each connecting point.
- 3- Position the sections next to each other and ensure that the tabs are overlapping correctly.
- 4- Position de TILE COVERS onto the cube's bases.
- 5- Insert the CONNECTING PINS in the tabs as you progress and manually engage the threads.
- 6- Once the sequence of cubes is connected, complete assembly by firmly tightening the CONNECTIN PINS.
- 7- Add BOLT FOR CUBE and NUT assemblies on the entire perimeter of your dock. If necessary, do not forget to fill the empty layers in-between the tabs with SPACERS.

SERVICES CONDUITS (WATER AND ELECTRICITY) – POWER PEDESTALS – LED LIGHT SYSTEM

The final step of routing electrical cables, water pipes, or our LED light system can be done at various stages of your assembly. Depending on the application, the geometries, and the environment you are working in, a working method will be determined. Contact your local Distributor or Candock's head offices for more information and insight in this regard.



CONNECTING PIN



SPECIFICATIONS

Material/Composition: High-density polyethylene resin

Available colors: Beige, Gray

Surface: Anti-skid

Dimensions: L : 24 cm (9.6") x W: 17.2 cm (6.88") / Shaft diameter : 4.547 cm (1.819")

Wall thickness: .0750 cm (0.300")

Needed tools: Assembly key for G2 connecting Pin

SKU NUMBERS

G2 CONNECTING PIN BEIGE: C01-000004

G2 CONNECTING PIN GREY: C01-000005

TERMINOLOGY

HEAD: Upper part of the CONNECTING PINS designed with a flat and anti-skid surface.

NOTCH: Manufactured recess in the pin's head that allows the tool to insert the key for screwing and unscrewing.

SHAFT: Make part of our coupling system; the threaded rod is inserted in our CANDOCK SLIDING NUTS.

ASSEMBLY PROCEDURE

1-Initiate the rotating process by hand.

2-When the CONNECTING PIN has access to the SLIDING NUT threads, proceed by screwing manually or mechanically with the proper tools.

3-Make sure to securely tighten the CONNECTING PINS until snug, without over-tightening them.

TIPS

1-When initially inserting the CONNECTING PINS in place, you can firmly "tap" the pin in place. Tapping the connectin pin ensures a firm "initial" grip of the shaft threads into the SLIDING NUT. Likewise, this "tap" helps you get the pin through the four (4) cube tabs resting on top of the SLIDING NUT.

2-Once the assembly process is completed, align the NOTCHES of every CONNECTING PIN using the manual key. This simple operation allows to quickly locate any CONNECTING PINS which could have unscrewed over time.

3-Always proceed with caution if using a power drill to fasten the CONNECTING PINS; the drill can tend to "kick." Use protective footwear. If using a power drill to unscrew pins, always loosen-up the pins manually before using the drill.

4- Never use an "impact tool" to fasten the connecting pins; it can damage the connecting pins and the assembly key for the drill as well.

SLIDING NUT



Material/Composition: High-density polyethylene resin

Available colors: Black

SKU NUMBER

SLIDING NUT: C01-000017

TERMINOLOGY

CHANNELS: Hooks molded on each side of the SLIDING NUT to securely insert the nut on the cube tabs.



ASSEMBLY PROCEDURE

Insert SLIDING NUT on the lowest available tab of the connection point.



TIPS

Always make sure no SLIDING NUTS are forgotten during the assembly process. This could result in having to dismantle the whole structure in two (2) pieces to re-insert the missing nuts.

BOLT FOR CUBE



SPECIFICATIONS

Material/Composition: High-density polyethylene resin
Available colors: White
Needed tools: Key for nut

SKU NUMBER

BOLT FOR CUBE: C01-000019

TERMINOLOGY

AUTO LOCKING RIBS: Locking ribs that ease the process of screwing and un-screwing the NUT from the BOLT FOR CUBE as it's locking into the cube tabs.



ASSEMBLY PROCEDURE

Insert BOLT FOR CUBE into the cube tabs at every connection point that another Candock accessory hasn't secured. Secure by firmly screwing the NUT with the proper tool. (KEY FOR NUT or RATCHET KEY FOR NUT)

TIPS

- It's very important to include the BOLT FOR CUBE and NUT combination on the entire perimeter of every Candock installation. This will greatly strengthen the cube assembly and assuring the longevity of the installation.
- If possible, we suggest fastening the BOLTS FOR CUBE and NUTS before putting the dock in the water. Proceeding on dry land eases the whole process.
- Make sure to include the needed SPACERS if the **tab configuration creates a void** in the assembly.

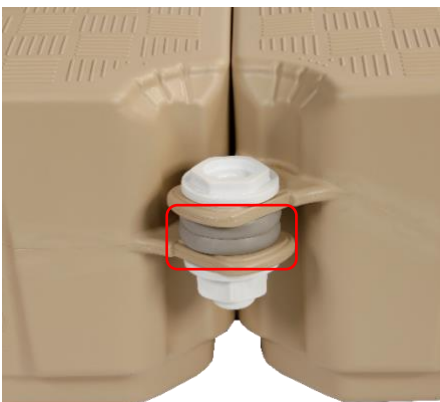

NUT



SPECIFICATIONS

Material/Composition: High-density polyethylene resin
Available colors: White
Needed tools: Key for nut

SKU NUMBER

NUT: C01-000018

ASSEMBLY PROCEDURE

Insert on each BOLT FOR CUBE and firmly tighten using the proper tools.

SPACER



SPECIFICATIONS

Material/Composition: High-density polyethylene resin
Available colors: Gray

SKU NUMBER

SPACER: C01-000020

ASSEMBLY PROCEDURE

Include spacers at every connection point where the **tab configuration creates a void** in the assembly.

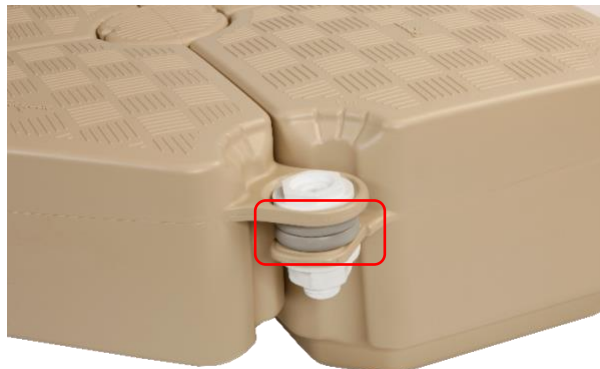
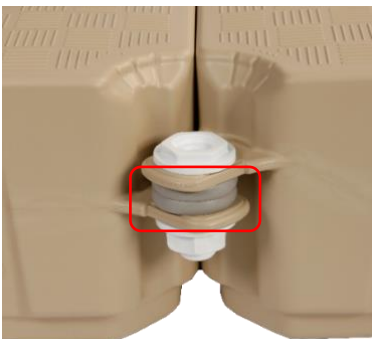

⦿ DOCK ACCESSORIES

BUMPER



SPECIFICATIONS

Material/Composition: High-density polyethylene resin with softer compound additive

Available colors: White

Needed tools: Key for nut

*Nut included

SKU NUMBER

BUMPER: C03-000008

TERMINOLOGY

AUTO LOCKING RIBS: Locking ribs that ease the process of screwing and un-screwing the NUT from the BUMPER as it's locking into the cube tabs



ASSEMBLY PROCEDURE

Simply insert the BUMPER into the cube tabs at the desired location. Secure by firmly screwing the NUT with the proper tool. (KEY FOR NUT or RATCHET KEY FOR NUT)

TIPS

- If possible, we suggest fastening the BUMPERS before putting the dock in the water. Proceeding on dry land eases the whole process.
- Make sure to include the needed SPACERS if the tab configuration creates a void in the assembly.

VERTICAL BUMPER



SPECIFICATIONS

Material/Composition: Aluminum and PVC extrusion

Available colors: White

Needed tools: 1 1/8" ratchet socket and wrench

***Bolt for cube and nut NOT included.**

SKU NUMBER

VERTICAL BUMPER: C03-000026

ASSEMBLY PROCEDURE

Insert the VERTICAL BUMPER onto the "pre-installed" BOLT FOR CUBE and NUT assembly using the provided hardware (bolt, washers, and nut). Secure by firmly tightening the nut onto the bolt.

TIPS

The VERTICAL BUMPER is ideal when a Pontoon-type boat is moored alongside a Candock. It provides optimal protection for the Pontoon's round-shaped tubes.

CLEAT



SPECIFICATIONS

Material/Composition: High-density polyethylene resin

Available colors: White

Needed tools: Key for nut

SWL: 500kg (1120 lbs)

*Nut included

SKU NUMBERS

CLEAT: C03-000007

TERMINOLOGY

AUTO LOCKING RIBS: Locking ribs that ease the process of screwing and un-screwing the NUT from the BUMPER as it's locking into the cube tabs.

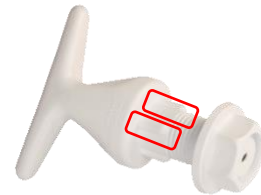

ASSEMBLY PROCEDURE

Simply insert the CLEAT into the cube tabs at the desired location. Secure by firmly screwing the NUT with the proper tool. (KEY FOR NUT or RATCHET KEY FOR NUT)

TIPS

- If possible, we suggest fastening the CLEATS before putting the dock in the water. Proceeding on dry land eases the whole process.
- Make sure to include the needed SPACERS if the tab configuration creates a void in the assembly.

FOLDING CLEAT ON CONNECTING PIN



SPECIFICATIONS

Material/Composition: High-density polyethylene resin, concrete and stainless steel 316

Available colors: Beige and Gray

SWL: 700kg (1500 lbs)

Needed tools: Key for nut

***Sliding nut NOT included**

SKU NUMBERS

FOLDING CLEAT ON CONNECTING PIN BEIGE: C03-000041

FOLDING CLEAT ON CONNECTING PIN GRAY: C03-000042

ASSEMBLY PROCEDURE

- 1-Initiate the rotating process by hand.
- 2-When the CONNECTING PIN has access to the SLIDING NUT threads, proceed by screwing manually using the manual key as a lever.
- 3-Make sure to securely tighten the FOLDING CLEAT ON CONNECTING PIN until snug, without over-tightening it.

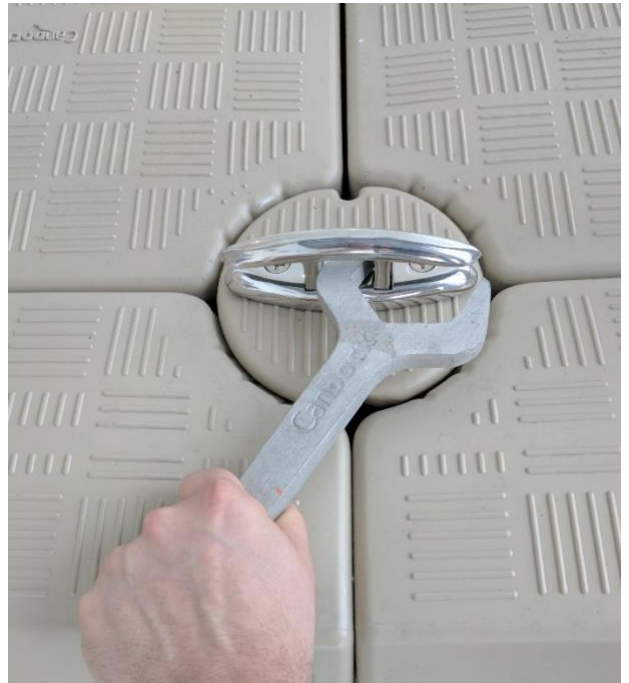

H.D. BOLLARD CLEAT



SPECIFICATIONS

Material/Composition: Stainless steel 316 L

Available colors: Beige and Gray (connecting pins)

SWL: 1000kg (2200 lbs)

Needed tools: G2 key for pin, and 1 1/8" ratchet socket or wrench

*Sliding nut NOT included

SKU NUMBERS

CLEAT HD STAINLESS STEEL 316 BEIGE: C03-000039

CLEAT HD STAINLESS STEEL 316 GRAY: C03-000040

ASSEMBLY PROCEDURE

1-Establish the location of the future H.D. BOLLARD CLEAT.

2-Remove the four (4) regular CONNECTING PINS that are surrounding the selected cube.

3-Insert the four (4) Connecting pins w/ 5/8" threaded rod included with the cleat. Initiate the screwing process by hand.

4-When the pin's threads are adequately engaged, manually tighten using the G2 key for connecting pin.

5-Make sure to securely tighten the connecting pins until snug, without over-tightening them.

6-Remove the nuts and washers from the steel threaded rods and put the H.D. BOLLARD CLEAT in place.

7-Secure the cleat by tightening the nuts and washers back in place with a 15/16" wrench key.

* The use of "anti-seize" grease on the threaded rods/nuts assemblies is strongly recommended.

** Do not install the H.D. BOLLARD TYPE CLEAT out the outskirts of your dock; always bring it one (1) cube inside the perimeter.

MODULAR RAILING SYSTEM

The Candock Modular Railing System has been developed with the same advantages as our Modular Floating Dock System. By allowing limitless configuration possibilities, they provide a tailored railing system for any Candock dock. The system consists of a few simple components that can provide a safe and aesthetical railing/guard rail for Candock docks.

Like our regular system, the railing/guard rail is installed on the Candock system using the same coupling mechanism. Depending on the specifications, geometries, application, and options required for your project, the same principles explained earlier apply. The coupling hardware and method vary depending on the post model.

The PVC railings and aluminum fittings are connected using a simple "push-pin" quick connect system. These fittings allow for junctions in-between lengths of PVC (if a section is longer than 20') caps, 45 degree corners, and 90 degree corners that allow for any shape of dock. Ninety (90) degree fittings are also used to create a smooth yet sturdy ending at the end of each railing section (image below).

1-SURFACE POST

It can be considered as a "guard-rail" if installed at "2-cubes" intervals with Candock's PVC pipes. See the detailed specification sheet for more information. This model replaces a CONNECTING PIN and it is to be screwed in place in combination with a SLIDING NUT. Specific tools are to be utilized. Please refer to the tools sections in the Owner's Manuals for instructions.

2-PERIPHERAL POST

It cannot be considered as a "guard-rail". Must be installed at "2-cubes" intervals or less. This model is to be installed on the Candock System's perimeter and is installed in the same fashion as a BOLT FOR CUBE/NUT assembly.

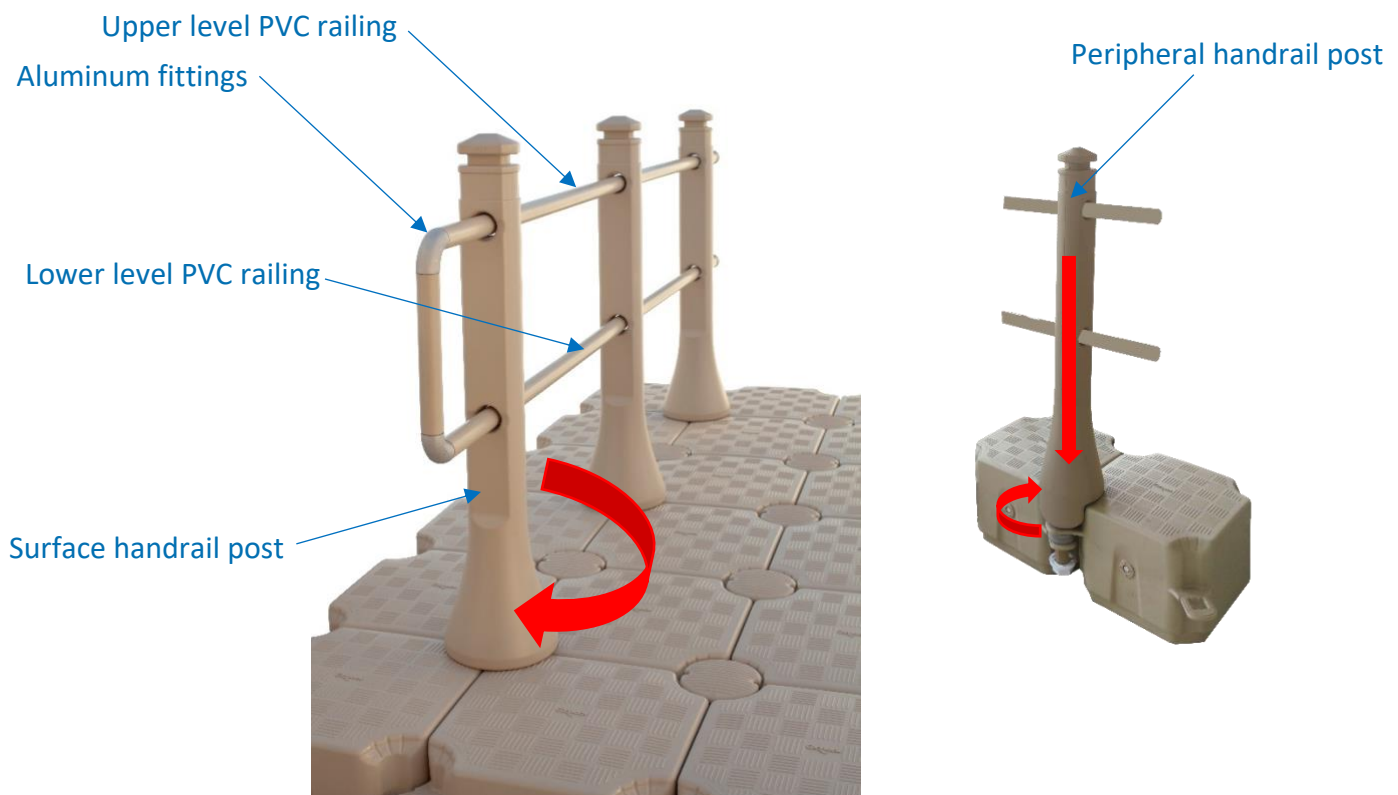

HANDRAIL POSTS AND RAILINGS (SURFACE AND PERIPHERAL)

SURFACE

PERIPHERAL

FITTINGS

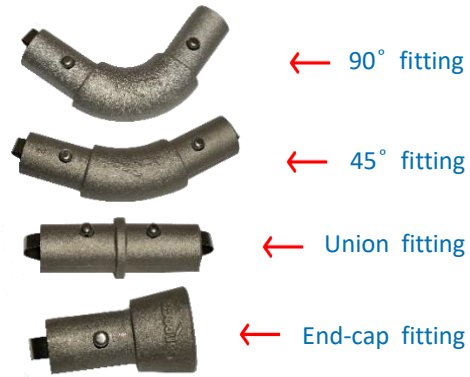
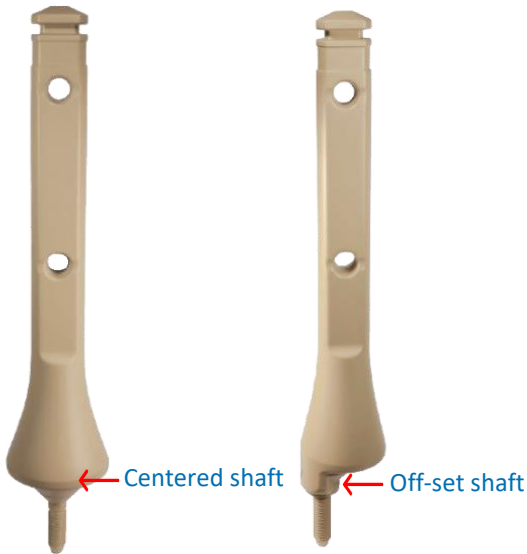

USEFUL LINKS AND RESOURCES:

[Website](#)

[YouTube](#)

SPECIFICATIONS

Material/Composition: High-density polyethylene resin and casted aluminum

Available colors: Beige and Gray

Dimensions posts: Post height: 107.cm (42.3'') / Railing height: 92.1cm (36.25'')

Dimensions railings: O/D 4.19cm (1.65'') x L 6.09m (20') per section

Weight: Post 2.27 kg (5 lbs.)

Needed tools: Key for surface post or Key for nut, Drilling Template for Handrail.

SKU NUMBERS

SURFACE POST BEIGE: C03-000001

SURFACE POST GRAY: C03-000002

PERIPHERAL POST BEIGE: C03-000003

PERIPHERAL POST GRAY: C03-000004

PVC RAILING BEIGE: C03-000043

PVC RAILING GRAY: C03-000044

90° FITTING: C03-000028

45° FITTING: C03-000027

UNION FITTING: C03-000030

END-CAP FITTING: C03-000029

DRILLING TEMPLATE FOR HANDRAIL: C04-000008

ASSEMBLY PROCEDURE

SURFACE POST

- 1-Determine the location of the post you want to install.
- 2- Using the proper tool, remove the CONNECTING PIN that is in the selected location.
- 3-Insert the surface post and initiate the rotating process by hand.
- 4-When the SURFACE POST has access to the SLIDING NUT threads, proceed by screwing manually or mechanically with the proper tool.
- 5-Make sure to tighten the SURFACE POST until snug, without over-tightening.

NOTES

-Intervals (spacing) between each post should be of 2 cubes if the railing system is utilized as a guard rail. PVC railings should also be included at both levels (upper and lower) to provide sufficient rigidity for the whole assembly.

-A wider span can be considered if the railings are destined to provide walking/traffic assistance instead of preventing accidental falls off the dock.

Ropes could be considered for the horizontal railings instead of PVC if the railings are destined to provide walking/traffic assistance instead of preventing accidental falls off the dock.

PERIPHERAL POST

1-Determine the location of the post you wish to install.

2-Remove the potential installed BOLT FOR CUBE / NUT assembly at the selected location using the proper tool.

3-Insert the surface post while making sure to include the needed SPACERS (4x) and STRENGTHENING SPACER (1x) as you insert the post on the cube's tabs. The STRENGTHENING SPACER is to be inserted at the lowest possible point on the post's shaft. The "regular" SPACERS are to be inserted at the connection point where the **tab configuration creates a void** in the assembly. No SPACERS should be included higher than tab #4 (see image). The "neck" of the post must be "sitting" directly on top of the tab (or spacer) #4.

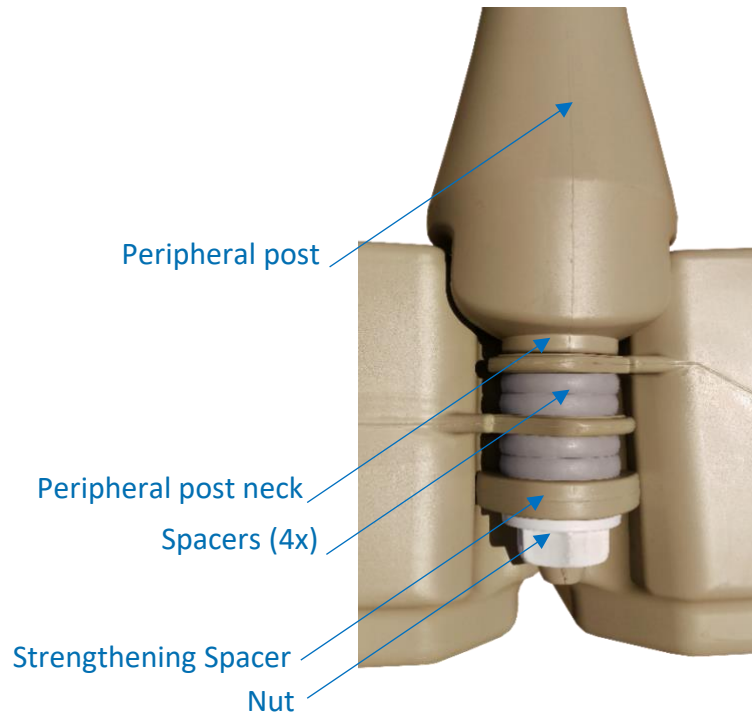

4-Finalize the assembly by firmly tightening the NUT at the bottom of the post's shaft.

TIP

-To create a stiffer assembly in a calm body of water, link the upper and lower PVC rails by adding a vertical PVC section of 29.2cm (11 ½") between (2x) 90° fittings. This step creates a stiffer assembly between the upper and lower PVC rails.

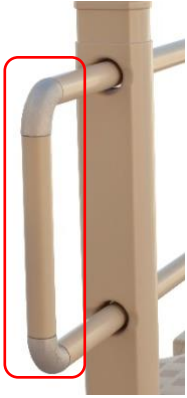

PRODUCT LIMITATIONS

- Regardless of the water conditions and main application of the floating dock, it is not recommended to use these handrails in conditions where waves are subjected to exceed 3 '(1m).
- Unless installed in an environment completely protected from wave action, the ropes or pipes must have buffers of at least 45cm (18") at each end to allow free movement of the ropes OR PVC pipes through the posts.
- If using rope instead of PVC pipes, we recommend using a rope possessing high resistance to friction and abrasion.
- If using PVC pipes, the corners or "end section" of the handrail system (45 deg. ,90 deg. End-cap) cannot withstand waves of more than 30cm (12") for extensive periods. We, therefore, recommend leaving any corner section or "end section" as free as possible by adding the necessary buffers to your pipe measurements.

LED LIGHT SYSTEM

The Candock LED light system shares many components and concepts found in our SERVICE CHANNEL SYSTEM. Replacing "solid colored" covers with translucent covers, we allow for light-emitting diodes (LED lights) to be installed within the covers to brighten the surface of your Candock dock.

As it is the case with our SERVICE CHANNEL system, the covers are secured on the Candock system using the same two (2) coupling mechanisms. Depending on the specifications, geometries, application, and options required for your project, the same principles explained earlier apply.

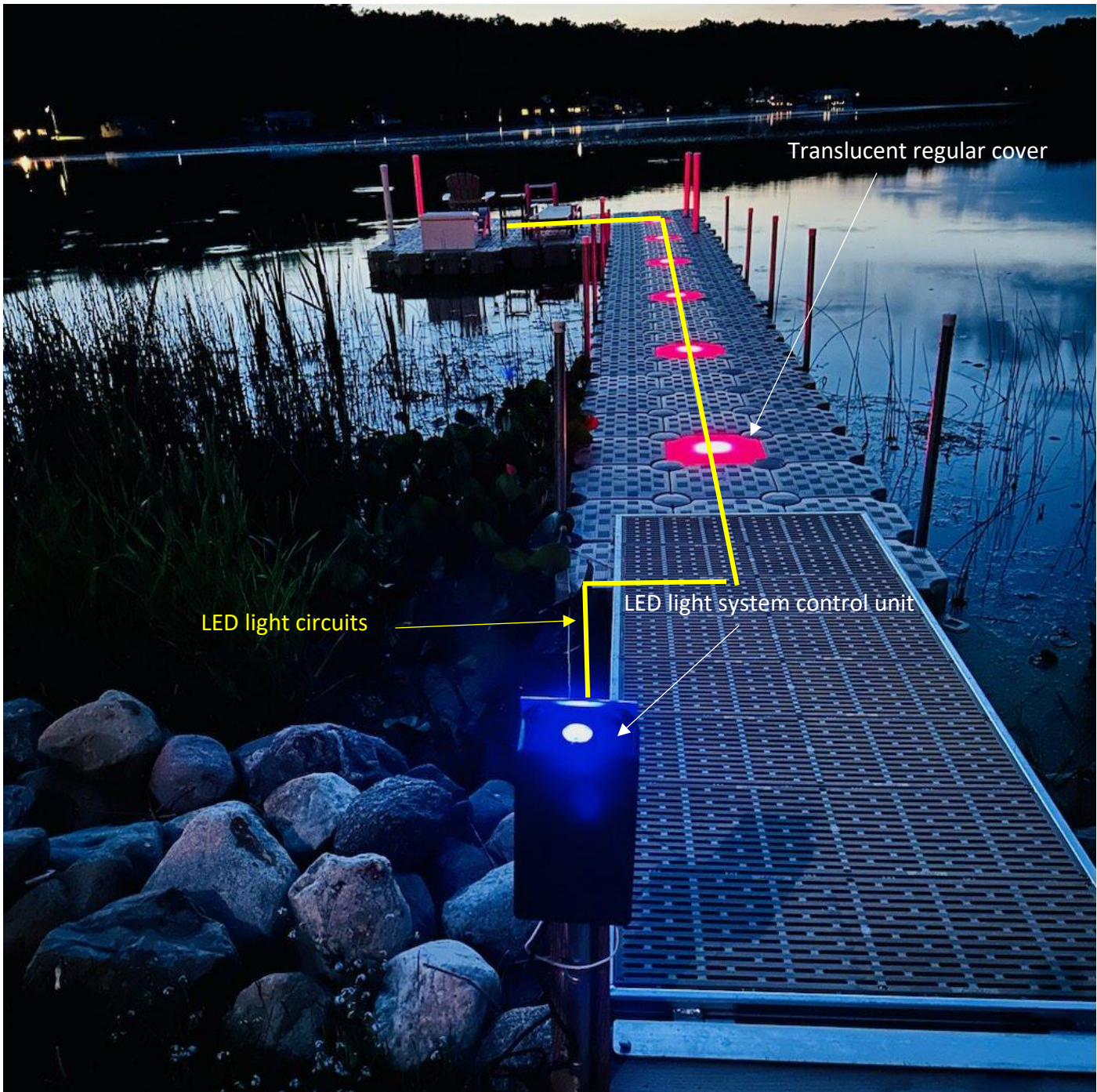



Regular service cube with translucent COVER

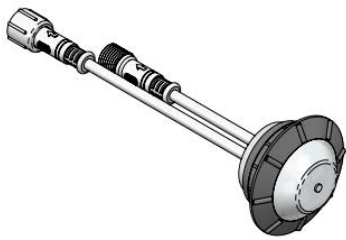

L.E.D. LIGHT



10FT EXTENSION CORD

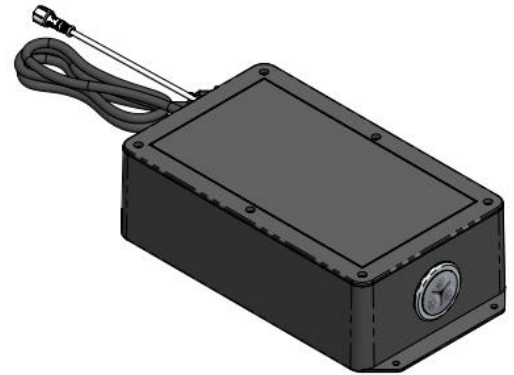

POWER UNIT

SPECIFICATIONS

Material/Composition: Covers: high-density polyethylene resin

Available colors: Covers: white/translucent

Light Bulbs: RGB

Needed tools: Basic tool kit for the converter assembly and connections.

[Youtube instructions](#)

SKU NUMBERS

TRANSLUCENT SERVICE COVER: C01-000010

EXTENSION CORD 10': C03-000035

LED LIGHT BULB: C03-000025

CONTROLL UNIT, NORTH AMERICA: C03-000059

CONTROLL UNIT, EUROPE: C03-000066

CONTROLL UNIT, U.K.: C03-000067

TERMINOLOGY

LIGHT BULB: Custom design light-emitting diodes that are destined to light-up any CANDOCK dock, pontoon, platform, or marina. Perfectly sealed and extremely durable, these light bulbs are the most reliable and practical solution to bring light to any CANDOCK floating structure. They are RGB, so you will have the choice between multiple colors.

EXTENSION CORD 10': These cables are mandatory if you have more than 1 cube between each light, and to get from the control unit to your first light.

CONTROL UNIT: This control unit is equipped with a photocell and allows you to change the color of your lights. It is also equipped with a DC to 12V current transformer to power your lights in complete safety.

ASSEMBLY PROCEDURE

PROCEDURE

1-Proceed with cube assembly without installing covers on the G2 SERVICE CUBE bases.

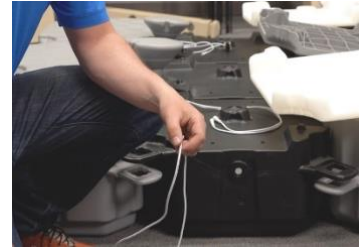

2- Plug and test the control unit. Under a bright light, the photocell will need to be covered to trigger the lights. Once you have confirmation everything is working as expected, proceed with the other steps. We also recommend to keep the control unit "ON" during the whole process, so you have confirmation that every lights you add on the systems works and are well plugged.

3- Starting from the control unit, insert the 1st light in the pre-drilled hole of the cover. The seal has a small slot that allows a firm fit. Once the 1st light is installed, repeat the same steps for further lights. Remember to start from shore and make your way from there.



4- When plugging the lights together, make sure to align both notches on the female and male connectors. Push the male connector until it touches the rubber gasket to assure a dust and water free connection.

5- Once you have a couple of lights plugged in, you can then start putting the covers on and fixing them in place with the connecting pins.





6- When installing the Control unit, it is best to put it as close to the dock as possible. From the control unit, run 10' extension cords (as needed) to the 1st light. The cable can be attached under the gangway for a cleaner installation.

NOTES

-The lights can be installed in the covers and the covers put in place as you go.

-You must ensure that you do not exceed the capacity of your converter. The limit is 50 lights or 200'/60m, whichever comes first. A second converter is required if you go past the number of lights or the maximum cable length.

-If you need to remove a light already installed in a cover, do not remove it by pulling on the wire. Push the light entirely inside the cover, remove the ring, and then it is easy to pull out the light from the cover.

-Our LED light system works with AC only. Many options exist to convert AC into DC current, but Candock does not provide this option.

OUTBOARD ENGINE MOUNT



SPECIFICATIONS

Material/Composition: High-density polyethylene resin and aluminum 6061
Needed tools: 1 1/8" ratchet socket and wrench
Suggested HP rating the outboard engine: 5 to 10 hp max.
***Bolt for cube and nut not included.**

SKU NUMBER

OUTBOARD ENGINE MOUNT: C03-000036

ASSEMBLY PROCEDURE

Simply insert the ENGINE MOUNT onto the "**pre-installed**" BOLT FOR CUBE and NUT assembly using the provided hardware (bolts, washers, and nuts). Secure by firmly tightening nuts.

TIPS

-Make sure to include the needed SPACERS if the tab configuration creates a void in the assembly.

WARNING

Use of this product in combination with our modular floating dock system converts it into a boat and is therefore considered as is by transport Canada (the same situation could apply to other countries) and must respect the laws applying to boats. Our dock system is not designed for navigation, and Candock Inc. disclaims any responsibility if used with an engine of any type whatsoever. It is the sole responsibility of the purchaser to comply with the laws in force.

SWIM LADDER



USEFUL LINKS AND RESOURCES:

[Website](#)

[YouTube](#)

[Box content](#)

SPECIFICATIONS

Material/Composition: High-density polyethylene resin

Available colors: Beige and Gray

Maximal weight rating: 114kg (250lbs)

Needed tools: G2 key for pin, Key for nut, and 9/16" ratchet socket and wrench

*Needed nuts and spacers included.

SKU NUMBERS

SWIM LADDER BEIGE: C03-000020

SWIM LADDER GRAY: C03-000021

ASSEMBLY PROCEDURE

- 1-Pre-assemble the ladder as shown on the [manual](#) included in the box.
- 2-Establish the desired location of the ladder.
- 3-Remove the (2x) regular CONNECTING PINS and BOLTS FOR CUBE located where you wish to install the ladder.
- 4-Insert and tighten the (2x) provided connecting pins with threaded rods.
- 5-Insert the two (2) treaded parts of the ladder's up-rights into the chosen tabs. Manually engage the threads of the NUTS.
- 6-Insert the threaded rods of the connecting pins into the uprights' holes and screw the brass nuts and washer firmly.
- 7-Firmly tighten the NUTS with the proper tool.

TIPS

- Make sure to include the (4x) needed SPACERS on the threaded shafts of the (2x) uprights (2 on each side).

BENCH



SPECIFICATIONS

Material/Composition: Aluminum and fiber-glass re-enforced polypropylene panels

Available colors: Beige and Gray

Maximal weight rating: 227kg (500lbs)

Needed tools: G2 key for pin, and ½" ratchet socket or wrench

[Youtube instructions](#)

SKU NUMBERS

BENCH BEIGE: C03-000011

BENCH GRAY: C03-000012

ASSEMBLY PROCEDURE

- 1-Establish the location of the future BENCH on the dock.
- 2-Remove the two (2) regular CONNECTING PINS located under the bench's future location.
- 3-Insert the 2 CONNECTING PIN W/ MULTI-BASE ADAPTOR that support the legs for the bench. Initiate the screwing process by hand.
- 4-When the pins are properly inserted, proceed by screwing manually using the key for pin as a lever inside the **pre-drilled hole**
- 5-Make sure to securely tighten the CONNECTING PIN W/ MULTI-BASE ADAPTOR until snug.
- 6-You can now assemble the bench parts (the two (2) panels and the two (2) frame units). While assembling the panels, use the aluminum re-enforced one for the seat and the regular one for the backrest. Properly align the mounting holes together while centering the panels on the frame units. We recommend using "long nose" pliers to prevent the bolts from stripping the plastic inserts while screwing the nuts in place.
- 7-Simply insert the bench assembly into the CONNECTING PIN W/ MULTI-BASE ADAPTOR.



REVOLVING AND FOLDING SEAT



SPECIFICATIONS

Material/Composition: Aluminum, plastic, and synthetic leather

Available color: Gray only

Maximal weight rating: 114kg (250lbs)

Needed tools: G2 key for pin

SKU NUMBER

REVOLVING AND FOLDING SEAT: C03-000013

ASSEMBLY PROCEDURE

- 1-Establish the location of the future REVOLVING AND FOLDING SEAT on the dock.
- 2-Remove the regular CONNECTING PIN that is under the seat's future location.
- 3-Insert the CONNECTING PIN W/ MULTI-BASE ADAPTOR that support leg for the bench. Initiate the screwing process by hand.
- 4-When the pin is properly inserted, proceed by screwing manually using the key for pin as a lever inside the **pre-drilled hole**
- 5-Make sure to securely tighten the CONNECTING PIN W/ MULTI-BASE ADAPTOR until snug.
- 6-Simply insert the REVOLVING AND FOLDING SEAT assembly into the CONNECTING PIN W/ MULTI-BASE ADAPTOR.



STORAGE CUBE



SPECIFICATIONS

Material/Composition: High-density polyethylene resin and ABS hatch.

Available colors: Beige and Gray

Needed tools: G2 key for pin, and #2 Philips head screwdriver

SKU NUMBERS

STORAGE CUBE G2 BEIGE: C03-000010

STORAGE CUBE G2 GRAY: C03-000009

ASSEMBLY PROCEDURE

See the regular CUBE assembly procedure.

NOTICE

- Note the orientation of latch for product ease of use.

To prevent the seal/gasket's premature wear, the pivoting handle is not tightened when items are shipped. A Philips head screwdriver is required to tighten the handle in place. Open the hatch, and the screw is underneath the handle. Make sure the handle can still move freely while compressing the seal.



MOORING WHIPS SUPPORT



SPECIFICATIONS

Material/Composition: Aluminum and stainless steel 316
Available colors: Beige and Gray
Needed tools: G2 key for pin, key for nut, 9/16" ratchet socket or wrench, and 1 1/8" ratchet socket and wrench

SKU NUMBERS

MOORING WHIPS SUPPORT BEIGE: C03-000037
MOORING WHIPS SUPPORT GRAY: C03-000038

ASSEMBLY PROCEDURE

- 1-Establish the location of the future MOORING WHIP SUPPORT.
- 2-Remove the regular CONNECTING PIN that is at the selected area.
- 3-Remove the nut and washer from the **CONNECTING PIN W/ 1/2" THREADED ROD** and set it aside. Insert the pin and initiate the screwing process by hand. When the pin is inserted correctly, proceed by screwing manually using the key for pin. This first component acts as an anchoring point for the whip support onto the dock.
- 4-Install the **BOLT FOR CUBE and NUT** assembly onto the tabs of the selected location.
- 5-Fasten your **mooring whip base*** against the aluminum plate to have access under the plate.
- 6-Take the whole assembly and fix it against the **CONNECTING PIN W/ 1/2" THREADED ROD** and the **BOLT FOR CUBE and NUT** assembly.
- 7-Complete by screwing the destined nuts and washers using the proper key wrench ratchet.

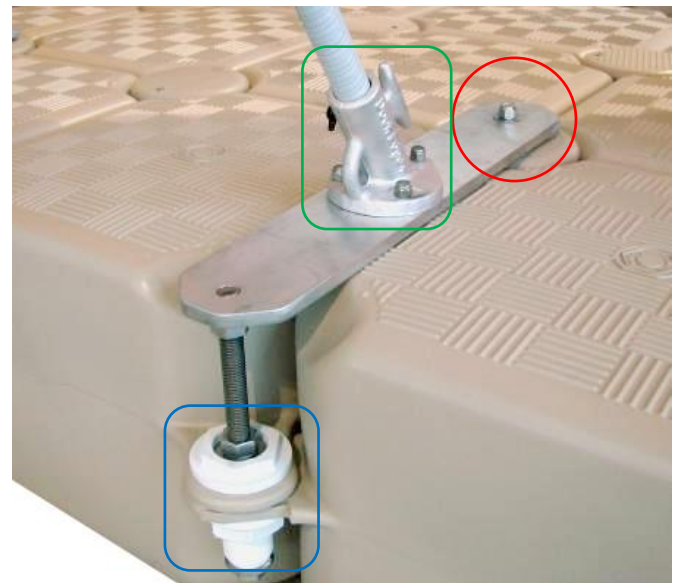

*Mooring whip base and whip sold separately. See [here](#) for our suggested whip supplier.

MODULAR KAYAK RACKS (SINGLE AND DOUBLE)

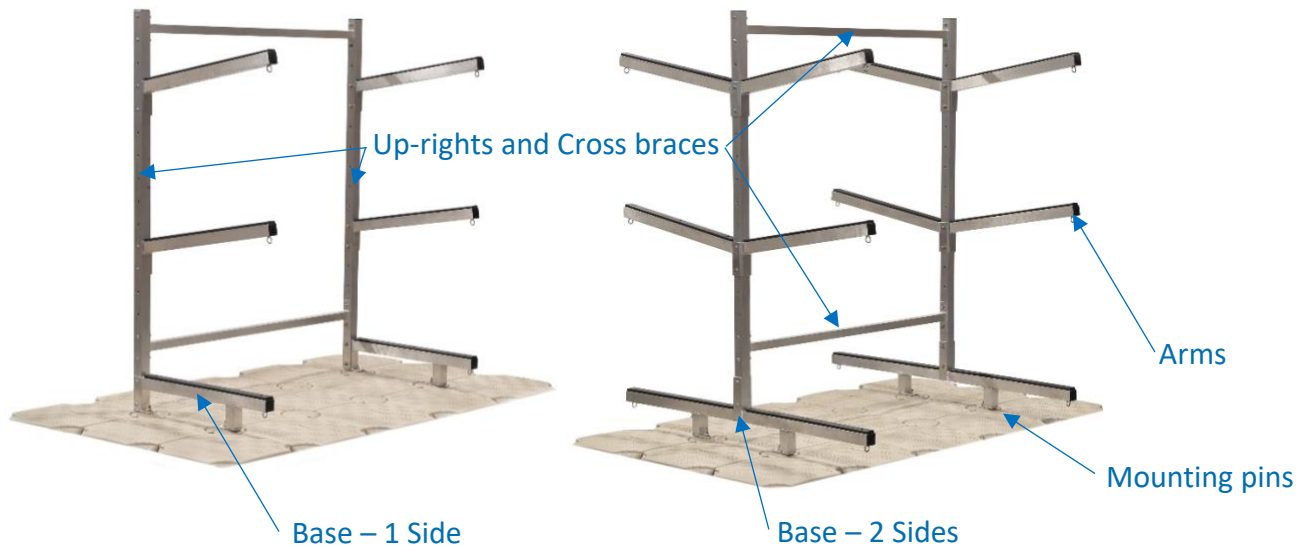

SPECIFICATIONS

Material/Composition: Aluminum, HDPE, and SS Hardware

Available colors: Beige or Gray

Needed tools: G2 key for pin, 9/16" ratchet socket or wrench, and 7/32"

Halen key

SKU NUMBERS

KAYAK RACK BASE – 1 SIDE (PAIR): C03-000032

KAYAK RACK BASE – 2 SIDES (PAIR): C03-000033

KAYAK RACK WALL MOUNT SUPPORT (PAIR): C03-000031

KAYAK RACK – 2 UPRIGHTS + 2 CROSS BRACES: C03-000034

KAYAK RACK ARMS (UNITS): C03-000015

KAYAK RACK MOUNTING PIN BEIGE (UNIT): C03-000051

KAYAK RACK MOUNTING PIN GRAY (UNIT): C03-000052

ASSEMBLY PROCEDURE

- 1-Establish the location of the future MODULAR KAYAK RACK on the dock.
- 2-Remove the regular CONNECTING PINS (4x) that are at the mounting points.
- 3-Insert the KAYAK RACK MOUNTING PINS that act as mounting points for the Kayak Rack bases. Initiate the screwing process by hand. When the pins are correctly inserted, proceed by screwing manually using the key for pin.
- 4-Position and secure the KAYAK RACK BASES on the mounting pins.
- 5-Position and secure the UP-RIGHTS and CROSS BRACES onto the KAYAK RACK BASES.
- 6-Position and secure the KAYAK RACK ARMS onto the UP-RIGHTS.

NOTICE

- A maximum of **75lbs per vessel space** should be applied on the rack.
- A maximum of **300lbs** should be applied on the ONE SIDE rack assembly.
- A maximum of **600lbs** should be applied on the TWO SIDES rack assembly.
- If using the TWO SIDES rack, weight should be evenly distributed between each side.

DOUBLE LAYER ROD KIT



SPECIFICATIONS

Material/Composition: High-density polyethylene resin and Stainless steel 316
Needed tools: Key for nut, (2x) 1 1/8" wrenches OR (2x) adjustable wrenches
*** 2 Bolts for cube and two (2) nuts included.**

SKU NUMBER

DOUBLE LAYER ROD KIT: C03-000022

ASSEMBLY PROCEDURE

- 1-Determine position of the DOUBLE LAYER ROD KIT.
- 2-Install the BOLT FOR CUBE and NUTS at the top and bottom connection points.
- 3-Insert the stainless-steel rod in the BOLT FOR CUBE while aligning the top and bottom layers. When the top layer is passed through, insert the **two (2) nuts and two (2) washers** needed between the two (2) layers.
- 4-Complete the installation by inserting the bottom nuts and washers and tightening all the above correctly.

TIPS

-Always start by assembling and installing the bottom layer first. Make sure you do not build longer sections than 10-15 cubes for the top layer. This is to keep the sections as manageable as possible. Drag that layer on top of the bottom layer. Before dragging too many sections, make sure to secure the previous ones with a few double-layer kits.

- Intervals (spacing) between each kit should be of 3 to 4 cubes at the most: depending on the application and environment.



⦿ ANCHORING PRODUCTS

PILINGS INTRODUCTION

The piling anchor method is one of the most common and popular approaches there is. Providing unmatched stability to the floating dock, they are often the preferred option if the environment and conditions allow it.

The anchoring of a floating dock with pilings requires most of the below conditions:

- Protected (sheltered) location which is not subject to high swells, waves, or wakes.
- Water depths in the low to medium range, depending on the types of pilings.
- Tractable nature of the seabed, depending on the types of pilings.

CANDOCK'S PILING SYSTEMS

Candock has developed a piling system that features noticeable advantages. Being a cost-effective, simple, and considered a temporary method, it also has its limitations. Through the below section, we demonstrate the best practices regarding our piling system.

Additionally, Candock has developed accessories that may be added to widen the scope of possibilities.. As an example, we stated above that water depths must be in the low to mid-range for the piling approach to be considered. With that in mind, in specific environments where a fixed structure is readily available and adjacent to the future floating dock installation, we are proposing accessories that allow for those water depths to be a bit more considerable while maintaining optimal stability. By fastening the piles' upper section onto those existing fixed structures (seawall, fixed crib dock, fixed dock on posts, etc.), we can achieve optimal stability while allowing deeper waters.

OTHER PILING ATTACHMENT OPTIONS

Candock also developed piling attachments to help our customers who already have existing piles which they can secure their Candock dock. The below section illustrates the most common accessories Candock has been using in the past years.

CANDOCK'S PILING SYSTEMS



OTHER PILING ATTACHMENT OPTIONS

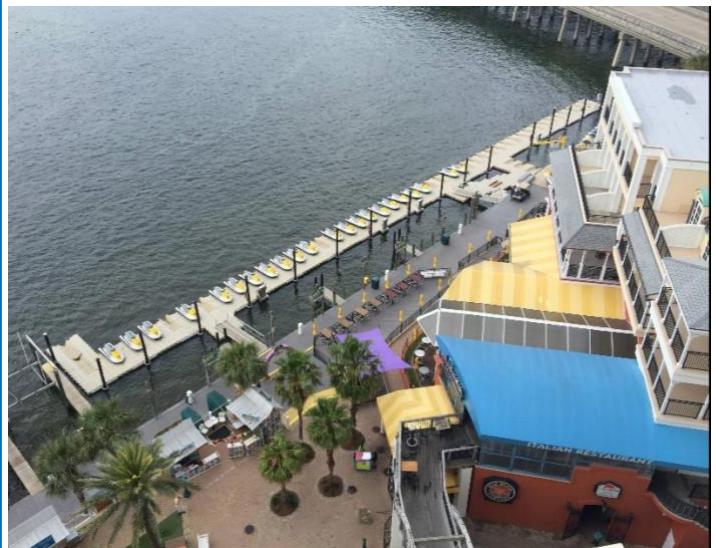

POST CUBE + 2 7/8" X 0.120 GALVANIZED STEEL PILE + 3" PVC SLEEVE AND CAP



Regular



Low-profile

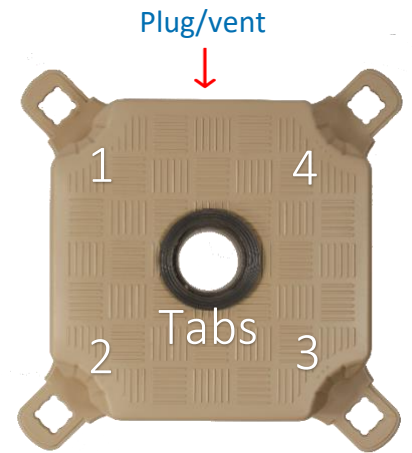

2 7/8" Steel pile



3 1/2" PVC sleeve



3 1/2" PVC cap & Rubber insert

USEFUL LINKS AND RESOURCES:

[YouTube](#)

[Website](#)

TAB POSITIONS

	#6
	#5
	#4
	#3
	#2
	#1
	#0
	#-1

SPECIFICATIONS

Material/Composition: High-density polyethylene resin, ABS flange, expanded polystyrene, galvanized steel, and PVC

Available colors: Beige and Gray

Surface: Anti-skid

Dimensions: L x W: 48 cm (19") x 48 cm (19") H: 36 cm (14")

Dimensions (low profile cube): L x W: 48 cm (19") x 48 cm (19") H: 23 cm (9")

Weight: Cube: 9 kg (20 lbs.) / Low profile cube: 8 kg (17 lbs.)

Needed tools: G2 key for pin, Key for nut, piling bull, piling driver, piling lever, but saw or zip cut grinder, PVC glue, and ratchet tool kit

SKU NUMBERS

G2 POST CUBE BEIGE: C06-000002

G2 POST CUBE GRAY: C06-000003

LOW PROFILE G2 POST CUBE BEIGE: C06-000005

LOW PROFILE G2 POST CUBE GRAY: C06-000005

2 7/8" GALVANIZED STEEL PILE: B0057

3 1/2" PVC SLEEVE: C06-000001

PVC CAP: C06-000019

TERMINOLOGY

FLANGE: Ultra-resistant plastic insert that allows a fluid yet durable system. It allows the POST CUBE to move up and down on the pile (with tidal or seasonal variations) without any restriction while ensuring a sturdy and durable anchoring method.

ASSEMBLY PROCEDURE

See the CUBE assembly procedure.

IMPORTANT PRINCIPLES

The below principles and notions apply to Candock's piling system in general. We recommend that the specifications of the combined products remain unchanged. Outside diameters of both the steel piles and PVC sleeves and the below guidelines are of the utmost importance to ensure the components' proper functioning altogether. See diagrams on the following page for additional visual explanations.

WATER DEPTH: Water depths should not exceed 2m (6.6') to ensure optimal stability.

NATURE OF SEABED: The composition of the soil/ground underwater must be tractable. I.E., Sand, mud, or small gravel.

PILEDEPTH : The piles should be inserted in the ground at 60cm (2'), ideally 90cm (3').

VERTICALITY: All piles should be perfectly vertical after installation is complete. The use of a level is highly recommended.

PROTECTED ENVIRONMENT: Any Candock system that is to be anchored with our piling system should not be subjected to waves of more than 60cm (2'). Candock's piling system is extremely restrictive in the amount of leeway it will allow to the dock. Aggressive waters may translate to premature wear of the components.

CANDOCK'S PILES WORK IN PAIRS: Candock's piling system implies that the piles are configured in pairs.

EACH PAIR OF POST CUBES SHOULD BE AT MAXIMAL INTERVALS OF 7m TO 9m (23 TO 30'): To maintain optimal stability and linear geometry, each pair of post cube should not exceed a distance of more than 9m (30').

OTHER CUBES ON 3 SIDES SHOULD ALWAYS support POST CUBES.: In other words, a post cube should never be installed on the outside corner of a Candock dock. It should always be recessed inside of 1 cube; on at least one (1) side.

POST CUBES SHOULD NEVER RUB DIRECTLY AGAINST THE STEEL PILES: This implies that the lengths of PVC sleeves must always span the total length of seasonal or tidal fluctuations of water levels. The PVC sleeve should be going deep enough for the post cube to rub on the PVC sleeve at the lowest possible water levels.

PVC CAPS (INCLUDING RUBBER INSERT) ARE MANDATORY: Each pile/PVC sleeve combination should be completed with a glued PVC cap and rubber insert.

TIPS

-Candock suggests that the piles protrude of approximately 1m to 1.5m (3-5 ft.) above the dock surface; at an average high-water level. Doing this allows for an insurance policy if the water level should unforeseeably rise.

PILE POSITION EXAMPLES

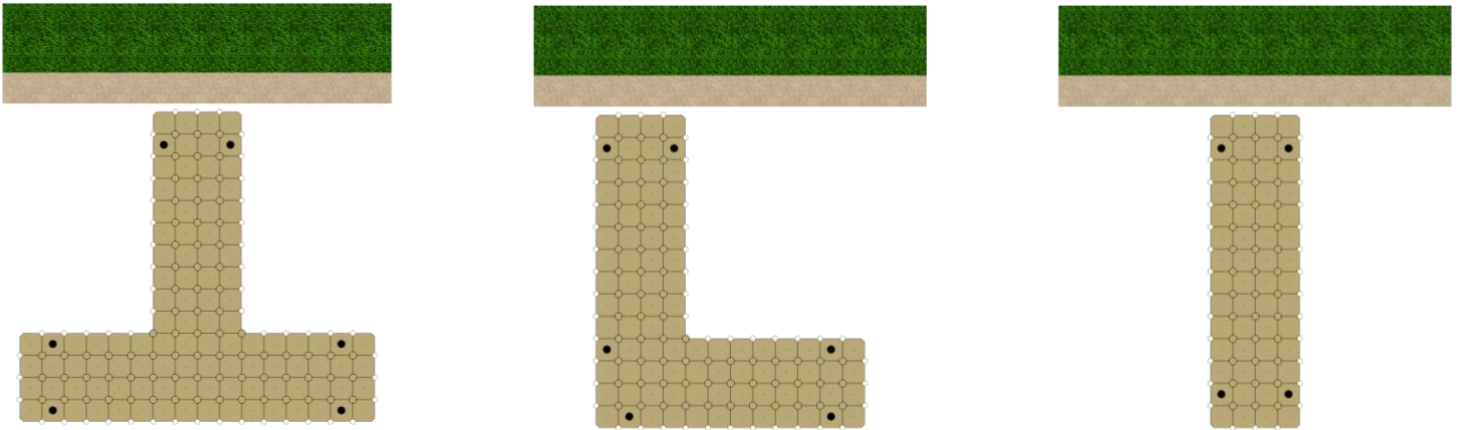

ALL FEATURED PILES ARE WORKING IN PAIRS AND ARE SUPPORTED/SURROUNDED ON AT LEAST 3 SIDES.

MAXIMAL DISTANCE BETWEEN EACH SET OF PILES IS LESS THAN 9M (30')

POST CUBE / STEEL PILE / PVC SLEEVE AND CAP COMBINATION

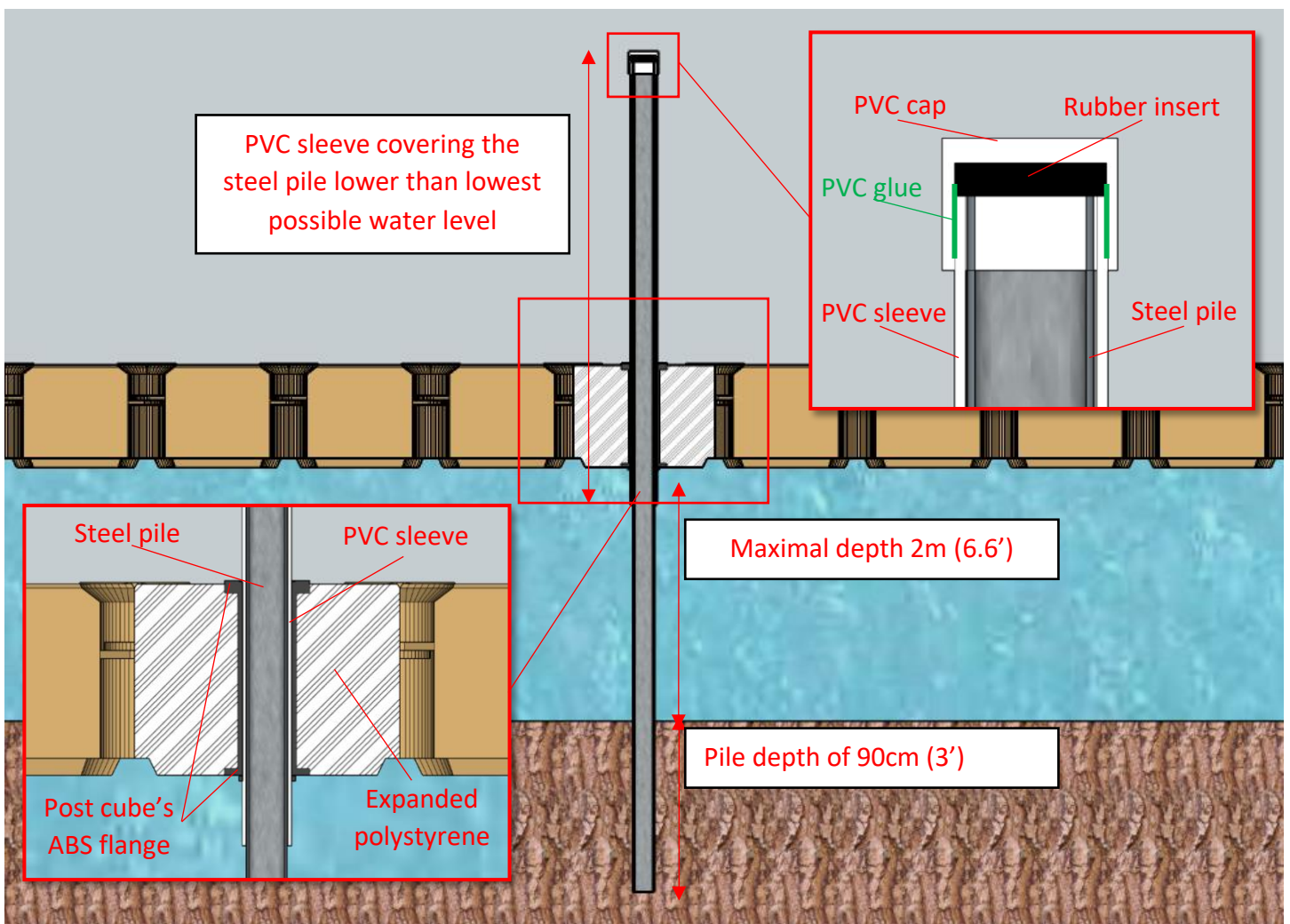

A FEW EXAMPLES



1 11/16" X 0.10 GALVANIZED STEEL PILE AND CAP

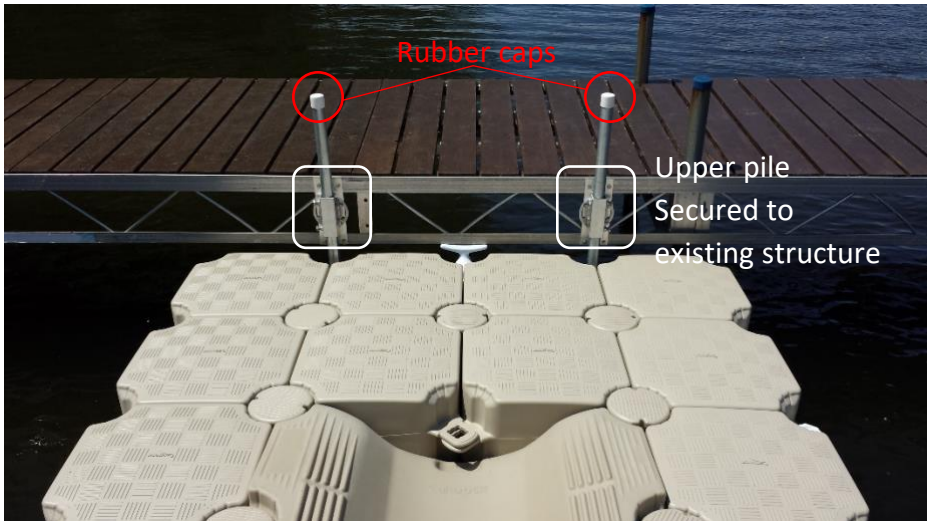

SPECIFICATIONS

Material/Composition: Galvanized steel

Needed tools: 1 11/16" pile driver and sledgehammer

SKU NUMBERS

PILE 1 11/16" X 0.10 GALVANIZED STEEL: C06-000034

1 11/16" RUBBER CAP: C06-000018

IMPORTANT PRINCIPLES

The below principles and notions apply the 1 11/16" piling system in general. The specifications of the combined products must remain unchanged. Outside diameters of the steel pile and the below guidelines are of the utmost importance to ensure the components' proper functioning.

UPPER SECTION OF THE PILE MUST BE SECURED TO EXISTING FIXED STRUCTURE: Candock provides a few alternatives to secure the top portion of the pile to a shore-fixed structure; see lower in this manual for details. Other accessories and hardware may also be acquired locally to perform the task.

PILE SUPPORT FOR 1 11/16" STEEL PILE

SHORESIDE PILE SUPPORT FOR 1 11/16" STEEL PILE

LOWER SECTION OF THE PILE MUST BE INSERTED IN THE SEABED OF AT LEAST 60cm (2'): See the 1 11/16" pile driver and sledgehammer instructions.

WATER DEPTH SHOULD NOT EXCEED 2.4m (8'): For the pile to provide sufficient rigidity, the pile's overall free span cannot exceed 2.4m (8').

VERTICALITY: All piles should be perfectly vertical after installation is complete. The use of a level is highly recommended.

PROTECTED ENVIRONMENT: Any Candock system that is to be anchored with our piling system should not be subjected to waves of more than 60cm (2'). Candock's piling system is extremely restrictive in the amount of leeway it will allow to the dock. Aggressive waters may translate to premature wear of the components.

CANDOCK'S PILES WORK IN PAIRS: Candock's piling system implies that the piles are to be configured in pairs; or more.

ADJUSTABLE PILE SUPPORT 2-7/8" - GALVANIZED

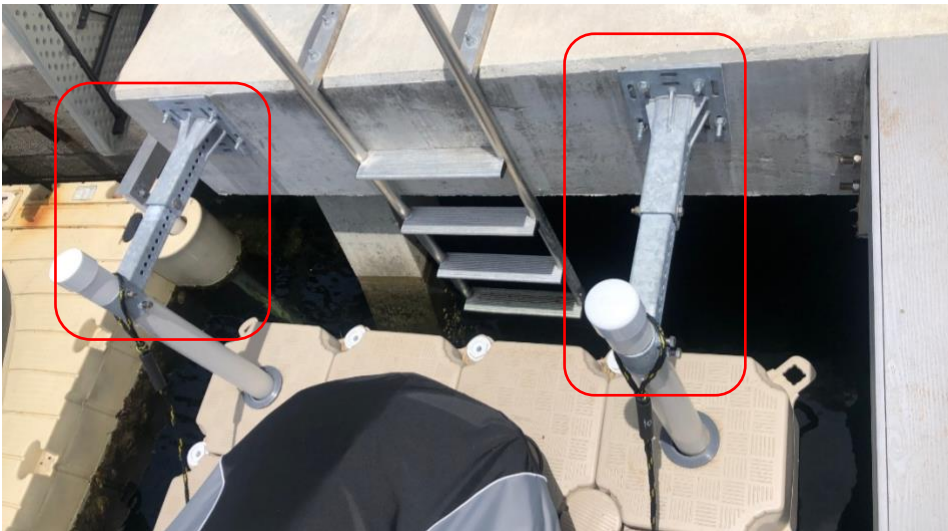

SPECIFICATIONS

Material/Composition: Galvanized steel

Needed tools: 2 7/8" pile driver, sledgehammer, 3/4" ratchet socket and wrench, proper tools and hardware to secure the pile support on the existing fixed structure.

SKU NUMBER

ADJUSTABLE PILE SUPPORT 2-7/8" GALVANIZED: C07-000007

IMPORTANT PRINCIPLES

The below principles and notions apply the ADJUSTABLE PILE SUPPORT 2-7/8" GALVANIZED. The specifications of the combined products must remain unchanged. Outside diameters of the steel pile and the below guidelines are of the utmost importance to ensure the components' proper functioning.

PILE SUPPORT MUST BE SECURELY BOLTED ON THE EXISTING STRUCTURE: Candock does not provide basic hardware; these should be purchased locally. A proper assessment of the existing structure is essential to ensure a strong assembly.

LOWER SECTION OF THE PILE MUST BE INSERTED IN THE SEABED OF AT LEAST 60cm (2'): See the 2 7/8" pile driver and sledgehammer instructions.

WATER DEPTH SHOULD NOT EXCEED 3m (10'): For the pile to provide sufficient rigidity, the pile's overall free span cannot exceed 3m (10').

VERTICALITY: All piles should be perfectly vertical after installation is complete. The use of a level is highly recommended.

PVC SLEEVE: All piles should be covered with a PVC sleeve and Cap to prevent the POST CUBES' premature wear.

PROTECTED ENVIRONMENT: Any Candock system that is to be anchored with our piling system should not be subjected to waves of more than 60cm (2'). Candock's piling system is extremely restrictive in the amount of leeway it will allow to the dock. Aggressive waters may translate to premature wear of the components.

CANDOCK'S PILES WORK IN PAIRS: Candock's piling system implies that the piles are to be configured in pairs; or more.

HDPE PILE GUIDE FOR 2 7/8" STEEL PILE

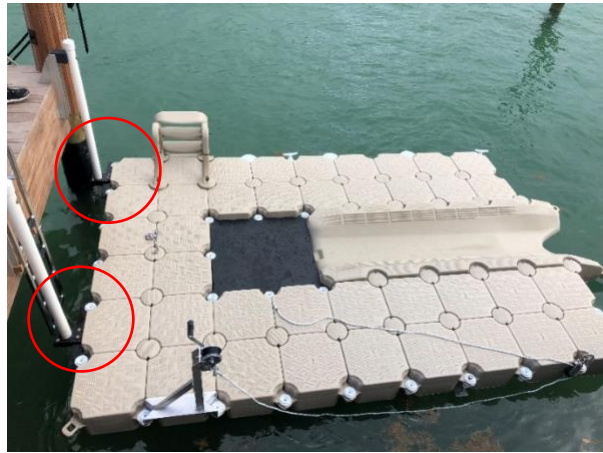

SPECIFICATIONS

Material/Composition: High-density polyethylene
Needed tools: 2 7/8" pile driver, sledgehammer, key for nut, but-saw or zip cut grinder, PVC glue, and 9/16" ratchet socket and wrench

SKU NUMBER

HDPE PILE GUIDE FOR 2 7/8 " STEEL PILE: C06-000008

IMPORTANT PRINCIPLES

The below principles and notions apply to the HDPE PILE GUIDE FOR 2 7/8" STEEL PILE. The specifications of the combined products must remain unchanged. Outside diameters, the steel pile, and the below guidelines are of the utmost importance to ensure the components' proper functioning.

UPPER SECTION OF THE PILE MUST BE SECURED TO EXISTING FIXED STRUCTURE: Candock provides a few alternatives to secure the top portion of the pile to a shore-fixed structure; see lower in this manual for details. Other accessories and hardware may also be purchased locally to perform the task.

- "Z" BRACKET FOR 2 7/8" STEEL PILE (16" AND 6")

- GALVANIZED STEEL ADJUSTABLE 2 7/8" STEEL PILE SUPPORT

LOWER SECTION OF THE PILE MUST BE INSERTED IN THE SEABED OF AT LEAST 60cm (2'): See the 2 7/8" pile driver and sledgehammer instructions.

WATER DEPTH SHOULD NOT EXCEED 3m (10'): For the pile to provide sufficient rigidity, the pile's overall free span cannot exceed 3m (10').

VERTICALITY: All piles should be perfectly vertical after installation is complete. The use of a level is highly recommended.

PVC SLEEVE: All piles should be covered with a PVC sleeve and Cap to prevent the HDPE guides' premature wear.

PROTECTED ENVIRONMENT: Any Candock system that is to be anchored with our piling system should not be subjected to waves of more than 60cm (2'). Candock's piling system is extremely restrictive in the amount of leeway it will allow to the dock. Aggressive waters may translate to premature wear of the components.

CANDOCK'S PILES WORK IN PAIRS: Candock's piling system implies that the piles are to be configured in pairs; or more.

TIPS

-Make sure to include the needed SPACERS if the tab configuration creates a void in the assembly

"Z" BRACKET FOR 2 7/8" STEEL PILE (16" AND 6")

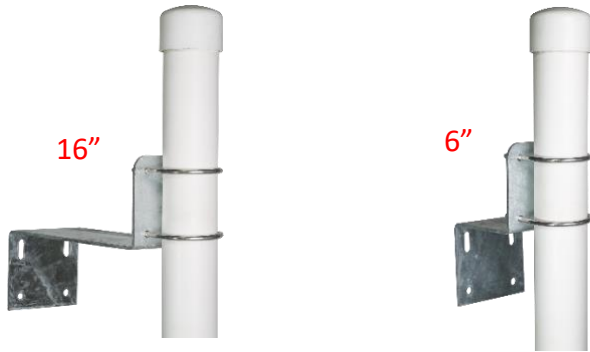

SPECIFICATIONS

Material/Composition: Galvanized steel

Needed tools: 2 7/8" pile driver, sledgehammer, 9/16" ratchet socket or wrench, proper tools, and hardware to secure the Z brackets on the existing fixed structure.

SKU NUMBERS

"Z" BRACKET FOR 2 7/8 " STEEL PILE (16") GALVANIZED STEEL: C07-000003

"Z" BRACKET FOR 2 7/8 " STEEL PILE (6") GALVANIZED STEEL: C07-000005

"Z" BRACKET FOR 2 7/8 " STEEL PILE (16") SS 316: C07-000004

"Z" BRACKET FOR 2 7/8 " STEEL PILE (6") SS 316: C07-000006

IMPORTANT PRINCIPLES

The below principles and notions apply the "Z" BRACKET FOR 2 7/8" STEEL PILE (16" AND 6"). The specifications of the combined products must remain unchanged. Outside diameters, the steel pile, and the below guidelines are of the utmost importance to ensure the components' proper functioning. The best option between the 16" and 6" depends on the desired application. Generally, if the combination includes a POST CUBE, the 16" model prevails. For any other combination, the 16" or 6" can work.

Z BRACKET MUST BE SECURELY BOLTED ON THE EXISTING STRUCTURE: Candock does not provide basic hardware; these should be purchased locally. A proper assessment of the existing structure is essential to ensure a strong assembly.

LOWER SECTION OF THE PILE MUST BE INSERTED IN THE SEABED OF AT LEAST 60cm (2'): See the 2 7/8" pile driver and sledgehammer instructions.

WATER DEPTH SHOULD NOT EXCEED 3m (10'): For the pile to provide sufficient rigidity, the pile's overall free span mustn't exceed 3m (10').

VERTICALITY: All piles should be perfectly vertical after installation is complete. The use of a level is highly recommended.

PVC SLEEVE: All piles should be covered with a PVC sleeve and Cap to prevent the POST CUBES' premature wear.

PROTECTED ENVIRONMENT: Any Candock system that is to be anchored with our piling system should not be subjected to waves of more than 60cm (2'). Candock's piling system is extremely restrictive in the amount of leeway it will allow to the dock. Aggressive waters may translate to premature wear of the components.

CANDOCK'S PILES WORK IN PAIRS: Candock's piling system implies that the piles are to be configured in pairs; or more.

PILE SUPPORT FOR 1 11/16" STEEL PILE

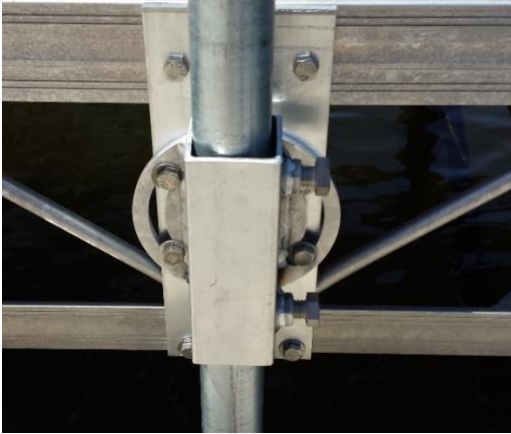

SPECIFICATIONS

Material/Composition: Aluminum

Needed tools: 1 11/16" pile driver, sledgehammer, 3/4" ratchet socket or wrench, proper tools, and hardware to secure the pile support on the existing fixed structure.

SKU NUMBERS

PILE SUPPORT FOR 1 11/16" STEEL PILE MODULAR: C05-000040

IMPORTANT PRINCIPLES

The below principles and notions apply the PILE SUPPORT FOR 1 11/16" STEEL PILE. The specifications of the combined products must remain unchanged. Outside diameters, the steel pile, and the below guidelines are of the utmost importance to ensure the components' proper functioning. These accessories allow for a wide array of applications, therefore, the list of possibilities is not elaborated. Nevertheless, the below principles apply. Please contact Candock or your local distributor to gather more insight on the potential application that Candock approves for these accessories.

PILE SUPPORT MUST BE SECURELY BOLTED ON THE EXISTING STRUCTURE: Candock does not provide basic hardware; these should be purchased locally. A proper assessment of the existing structure is essential to ensure a strong assembly.

LOWER SECTION OF THE PILE MUST BE INSERTED IN THE SEABED OF AT LEAST 60cm (2') *: See the 1 11/16" pile driver and sledgehammer instructions.

***EXCEPTIONS MAY APPLY DEPENDING ON APPLICATION, ENVIRONMENT, AND GEOMETRIES.**

WATER DEPTH SHOULD NOT EXCEED 2.4m (8'): For the pile to provide sufficient rigidity, the pile's overall free span cannot exceed 2.4m (8').

VERTICALITY: All piles should be perfectly vertical after installation is complete. The use of a level is highly recommended.

PROTECTED ENVIRONMENT: Any Candock system that is to be anchored with our piling system should not be subjected to waves of more than 60cm (2'). Candock's piling system is extremely restrictive in the amount of leeway it will allow to the dock. Aggressive waters may translate to premature wear of the components.

CANDOCK'S PILES WORK IN PAIRS: Candock's piling system implies that the piles are to be configured in pairs; or more.

A FEW EXAMPLES

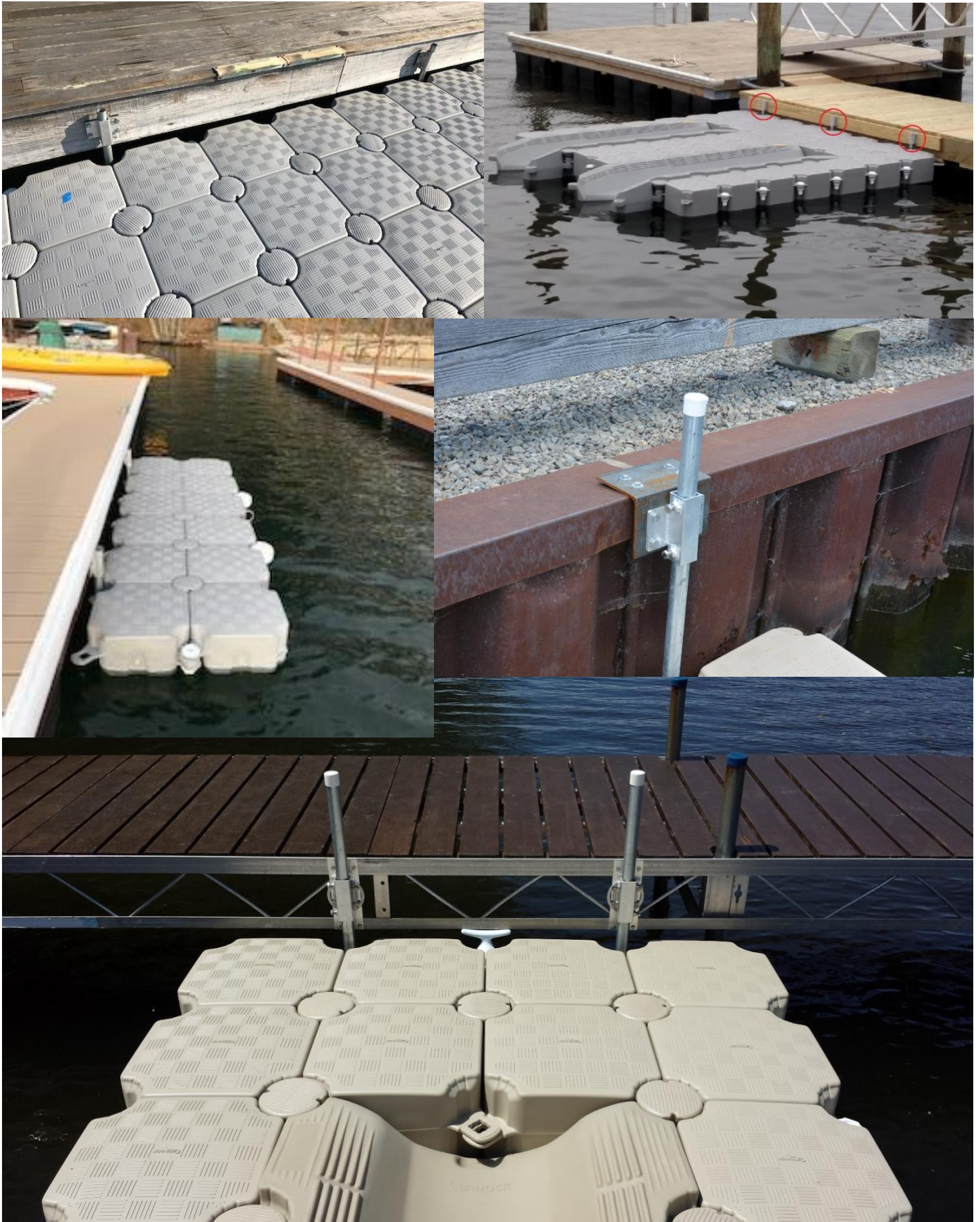

OTHER PILING ATTACHMENT OPTIONS

ADJUSTABLE PILE GUIDE FOR EXISTING PILES OF 15cm TO 38cm O/D (6" TO 15")



SPECIFICATIONS

Material/Composition: Stainless steel 316L and high-density polyethylene

Needed tools: Key for nut, zip cut grinder, long-nose pliers, and 17mm ratchet socket or wrench

*Bolt for cube and nuts not included.

SKU NUMBER

ADJUSTABLE PILE GUIDE FOR EXISTING PILES OF 15cm TO 38cm O/D (6" TO 15"): C06-000027

ASSEMBLY PROCEDURE

- 1-Using the two (2) needed BOLT FOR CUBE and NUTS, secure the stainless-steel mount onto the cube assembly.
- 2-Using the supplied hardware, fasten the adjustable 90 degrees "bumper" at the ideal position depending on the pile position.
- 3-Adjust the cable length and rollers quantity to optimize vertical movement while eliminating lateral movements.
- 4-Firmly tighten the NUTS onto the BOLTS FOR CUBE.

Proper hardware is already included in the bracket kit

TIPS

- Make sure to include the needed SPACERS if the tab configuration creates a void in the assembly.
- Distance between each PILE & PILE GUIDE alongside the Candock should not exceed 7-9m (23-30ft)

*****IMPORTANT.**

This type of anchor requires a specific configuration for each project. Please refer to a CANDOCK technician to validate your anchorage.

PILE GLIDE ADAPTOR (CAROLINA WATERWORKS - ALUMINUM OR GALVANIZED STEEL)

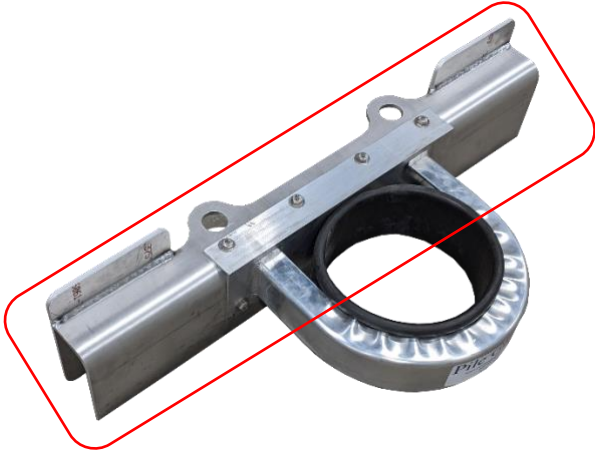

SPECIFICATIONS

Material/Composition: Aluminum or galvanized steel

Needed tools: Key for nut, and 1 1/8" ratchet socket and wrench

*Bolts for cube and nuts not included.

**Pile guide attachment not included, visit this website for more information <https://carolinawaterworks.com/>

SKU NUMBERS

PILE GLIDE ADAPTOR (CAROLINA WATER WORKS - ALUMINUM): C07-000001

ASSEMBLY PROCEDURE

1-Using the two (2) needed BOLTS FOR CUBE and NUTS, as well as the designated hardware, secure the PILE ADAPTOR mount onto the cube assembly.

2-Fasten the PILE GLIDE or other pile guide products onto the adaptor using adequate hardware. Candock does not provide any hardware; these should be purchased locally. A proper assessment of the selected pile guide is essential to ensure a strong assembly.

3-Firmly tighten all the hardware and NUTS onto the BOLTS FOR CUBE.

TIPS

Ensure that the pile's outside diameter is at least 15% smaller than the inside diameter of the chosen PILE GLIDE.

-Distance between each PILE & PILE GLIDE alongside the Candock should not exceed 7-9m (23-30ft)

CANDOCK'S UNDERWATER ANCHORING SYSTEMS

The underwater anchoring points with anchor lines approach is also a widely employed technique. The anchoring of a floating dock using this technique impose fewer restrictions. There is a wide variety of options regarding the components and possibilities through a multitude of possible combinations. This technique can easily be broken down into three (3) separate categories of accessories:

1-Connecting mechanism to the floating dock

2-Anchor line

3-Anchoring point in the seabed, lakebed, or riverbed.

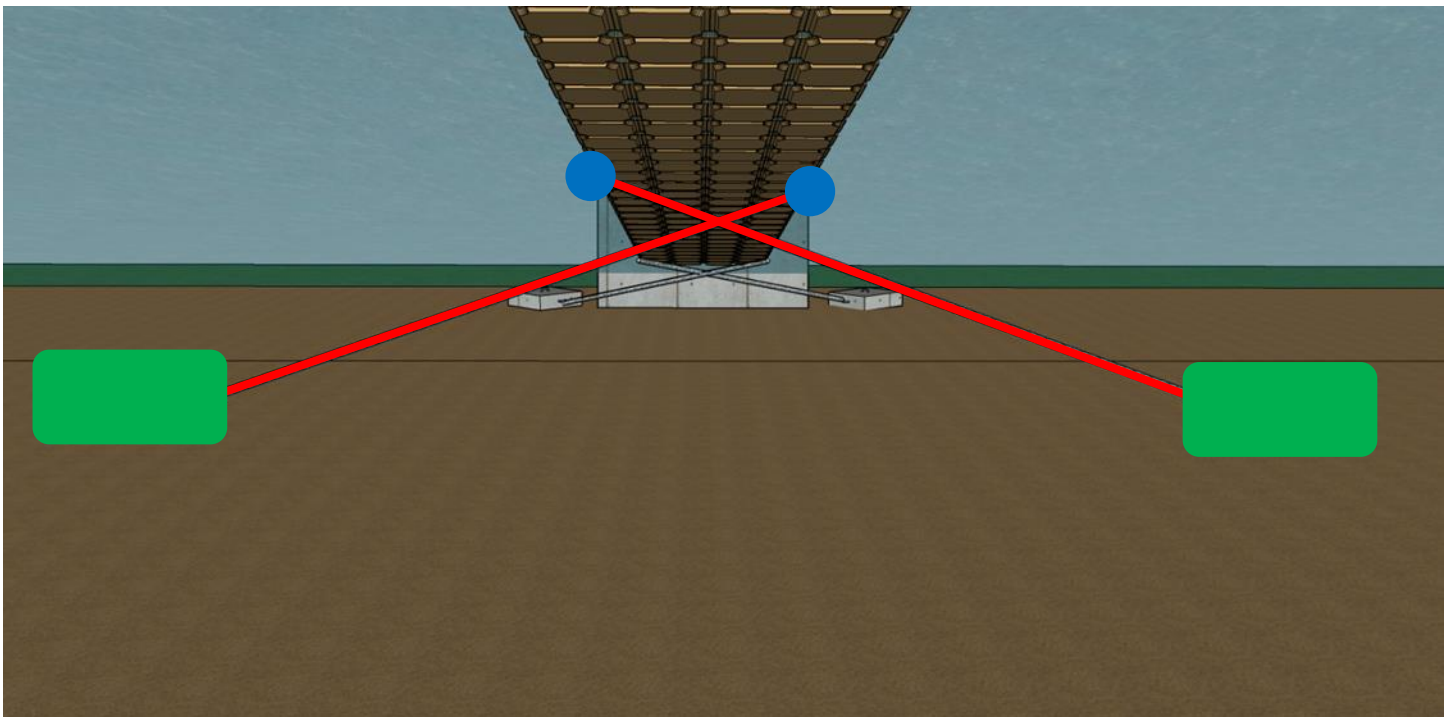

CANDOCK'S REGULAR ANCHORING METHOD AND ACCESSORIES

Candock has also developed its array of anchoring components. Due to our Modular Floating Dock systems' particularities, the market's readily available hardware and accessories were not sufficient. We have perfected and developed accessories for the three (3) categories mentioned above for the past two decades. Because of our floating dock systems' outstanding durability and resilience, each of the components has been designed to outperform any other floating dock system on the market. The flexibility and "energy-absorbing" nature of our systems have made Candock world-renowned for its unmatched durability and resilience.

CANDOCK'S "OPEN SEA" ANCHORING METHOD AND ACCESSORIES

Candock has also developed a **revolutionary anchoring approach** that sets the brand apart from its competitors. As our systems are extremely resilient, we've created a unique combination of accessories and techniques to develop the most robust and most resilient **OPEN SEA CONDITIONS** anchoring method available for a modular floating dock system like Candock. Look for the 3 Alpha signs () through the following sections to distinguish the related accessories.

***FOR THIS ANCHORING TECHNIQUE, IT IS HIGHLY RECOMMENDED THAT A QUALIFIED CANDOCK TECHNICIAN IS TO BE PRESENT DURING INSTALLATION TO SUPERVISE THE PROJECT.**

The below section elaborates on our systems' fundamentals while highlighting the best practices regarding this anchoring technique.

ANCHOR PLATE FOR CHAIN



SPECIFICATIONS

Material/Composition: stainless steel 316
SWL: 975kg (2145 lbs.)
Needed tools: 1 1/8" ratchet socket or wrench.
***Bolt for cube and nut NOT included**

SKU NUMBER

ANCHOR PLATE FOR CHAIN: C06-000037

ASSEMBLY PROCEDURE

Insert the ANCHOR PLATE FOR CHAIN into the BOLT FOR CUBE and firmly secure it with the provided hardware.

TIP

Make sure to angle it in the desired direction before final tightening.

CONNECTING PIN WITH PIVOTING ANCHOR PLATE FOR CHAIN



SPECIFICATIONS

Material/Composition: High-density polyethylene resin, concrete and stainless steel 316
Available colors: Beige and Gray
SWL: 1334kg (2500 lbs)
Needed tools: Key for pin
***Sliding nut NOT included**

SKU NUMBERS

CONNECTING PIN WITH PIVOTING ANCHOR PLATE FOR CHAIN BEIGE: C06-000041
CONNECTING PIN WITH PIVOTING ANCHOR PLATE FOR CHAIN GRAY: C06-000042

ASSEMBLY PROCEDURE

- 1-Disassemble the pivoting plate from the main shaft and set the **plate and dowel** aside.
- 2-Screw the connecting pin part at the desired location.
- 3-Laying belly down on the dock; reach down under the dock and reconnect the pivoting plate and dowel to the main shaft.

NOTICE

The CONNECTING PIN WITH PIVOTING ANCHOR PLATE FOR CHAIN has been designed to be installed on the edge of a Candock system with an EDGE CUBE perimeter. If you wish to install this anchoring accessory on a regular Candock system (no EDGE CUBE), you will most likely have to go in the water to complete the last step of the process.



CONNECTING PIN WITH ANCHOR RING FOR CHAIN (CONCRETE FILLED)



SPECIFICATIONS

Material/Composition: High-density polyethylene resin, concrete and stainless steel 316

Available colors: Beige and Gray

SWL: 1334kg (2500 lbs)

Needed tools: Key for pin

***Sliding nut NOT included**

SKU NUMBERS

CONNECTING PIN WITH ANCHOR RING FOR CHAIN (CONCRETE FILLED) BEIGE: C06-000039

CONNECTING PIN WITH ANCHOR RING FOR CHAIN (CONCRETE FILLED) GRAY: C06-000040

ASSEMBLY PROCEDURE

1-Screw the CONNECTING PIN WITH ANCHOR RING FOR CHAIN (CONCRETE FILLED) at the desired location.

TIP

Since the connecting point with the anchor line is often located directly underneath the floating dock, the CONNECTING PIN WITH ANCHOR RING FOR CHAIN (CONCRETE FILLED) provides the advantage of potentially discouraging any malicious person from stealing your floating system.

“HOT DIPPED” GALVANIZED STEEL CHAINS



SPECIFICATIONS

Material/Composition: Hot-dipped galvanized steel

SKU NUMBERS

CHAIN GALVANIZED STEEL, 5/16", GRADE 30: C06-000021
CHAIN GALVANIZED STEEL, 3/8", GRADE 30: C06-000020
CHAIN GALVANIZED STEEL, 5/8", GRADE 30: C06-000022
CHAIN GALVANIZED STEEL, 7/8", GRADE 30: C06-000023

SHACKLES



SPECIFICATIONS

Material/Composition: Hot-dipped galvanized steel or stainless steel 316L.

Needed tools: Long-nose plyers for the lock pin and regular plyers to secure the nut.

SKU NUMBERS

SHACKLE GALVANIZED STEEL, 5/16", LOCK: C06-000028
SHACKLE GALVANIZED STEEL, 3/8", LOCK: C06-000028
SHACKLE GALVANIZED STEEL, 5/8", LOCK: C06-000030
SHACKLE GALVANIZED STEEL, 7/8", LOCK: C06-000031
SHACKLE STAINLESS STEEL 316, 3/8", LOCK: C06-000032
SHACKLE STAINLESS STEEL 316, 7/16", LOCK: C06-000033

ELASTIC ANCHORING CABLES (TMS)



SPECIFICATIONS

Material/Composition: Stainless steel 316 L eyelet, natural latex, and Polyester sheath

SWL: 455kg (1000lbs)

MBS: 3181kg (7000lbs)

Elasticity: ELASTIC ANCHOR ROPE 1m (3'): 2m stretch (6')
ELASTIC ANCHOR ROPE 2m (6'): 4m stretch (12')

Needed shackles: SHACKLE STAINLESS STEEL 316, 7/16", LOCK: [SKU # B0255](#)

[YOUTUBE](#)

SKU NUMBERS

ELASTIC ANCHOR ROPE 1m (3'): C06-000024

ELASTIC ANCHOR ROPE 2m (6'): C06-000025

IMPORTANT PRINCIPLES

The below principles and notions apply to Candock's ELASTIC ANCHORING CABLES (TMS). The addition of these cables on the anchor lines allows for the dock's optimal stability in every condition. Suppose the water levels are subjected to fluctuations (tidal or seasonal). In that case, our elastic cables' addition to the anchor lines allows for optimal tension in the lines at all water levels. Depending on the application, environment, and applied forces to the dock, a Candock representative will determine a precise configuration layout. The below guidelines demonstrate the basic principles and best practices when these TMS cables are included in your dock system. Also, see the below diagrams for explanations on the below principles.

FLUCTUATION AMPLITUDES: If expected water fluctuations are higher than 2m, we recommend using the 2m elastic cable. If fluctuations are lesser than 2m, we suggest using the 1m elastic cable.

TMS POSITION ON THE ANCHOR LINE: The TMS cables should always be included in the line's upper-mid section. It prevents potential damages to the cable from seabed debris while allowing the upper section to be adjusted onto the floating dock.

TMS INSTALLATION AND TENSION: The TMS final adjustments (tension in the anchor lines) should be performed at a low water level (low tide). It allows for optimal tension when water fluctuates. The exact tension in the cables is challenging to determine, so we highly recommend meticulous monitoring of the first fluctuation cycles.

INCREASED RESISTANCE TO STRETCHING: The TMS cables can also be paired or tripled on a given anchor line to provide more stretching resistance. Depending on the load applied and the amplitude of the fluctuations, a Candock representative must determine the proper configuration.

ONE PIECE CHAIN: The TMS cable should be installed on a single section anchor line. It implies that the chain between the 2 connecting points of the TMS on the chain must be as long as the maximal stretch of the chosen TMS cable length (2m for the 1m cable; 4m for the 2m cable).

ASSEMBLY PROCEDURE

1-Install TMS cables on all anchor lines before installing the connecting lines.

2-Use proper shackles depending on chain gauge and application

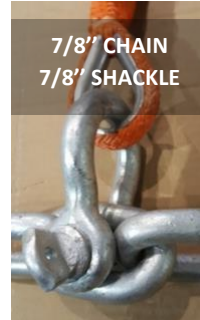
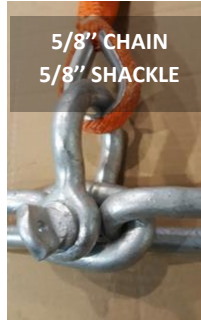
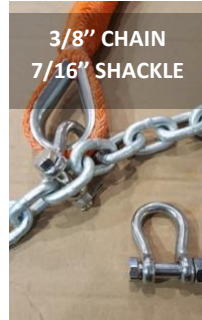
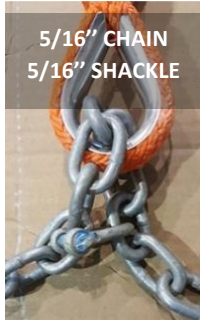
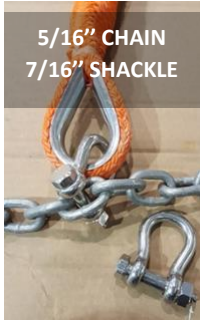

LINE CONFIGURATION

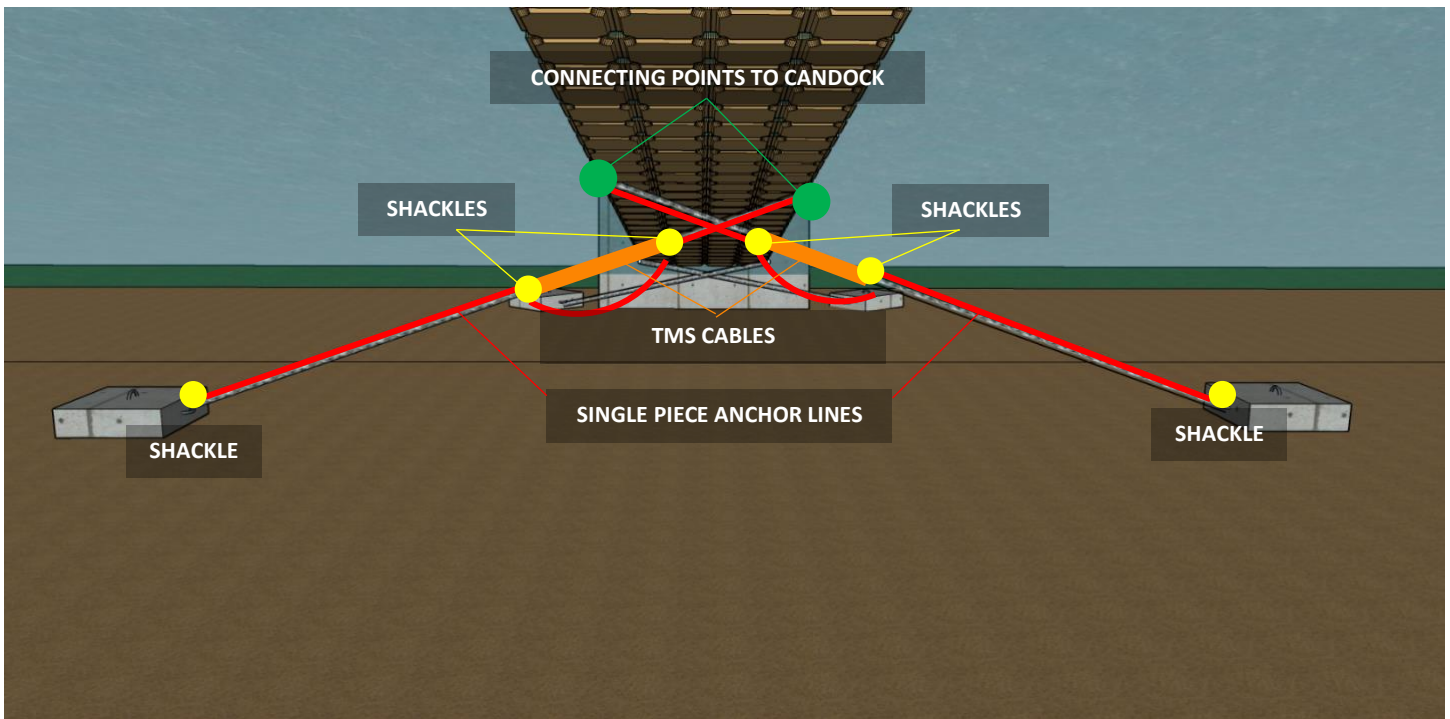

MISCELLANEOUS ANCHORING TECHNIQUES

In the miscellaneous category of techniques and accessories, there are multiple options. As a manufacturer, we developed tailored accessories and concepts. However, we kept in mind other alternatives available such as “custom-made” accessories or via third-party companies and marine contractors. The below list of accessories consists of our most often utilized accessories.

WALL ANCHORS AND EXTENSION PLATE FOR WALL ANCHORS



SPECIFICATIONS

Material/Composition: Stainless steel 316 or galvanized steel
Needed tools: Key for nut, 1 1/8” ratchet socket and wrench for the WALL ANCHORAGES and 3/4” ratchet socket and wrench for the EXTENSION PLATES and proper power tools and hardware to secure the wall anchorage and extension plate on an existing floating structure.
***Bolt for cube and nut included.**

SKU NUMBER

WALL ANCHOR GALVANIZED STEEL:
WALL ANCHOR STAINLESS STEEL 316: C06-000009
WALL ANCHORING ANGLE PLATE: C06-000036

ASSEMBLY PROCEDURE

Simply insert the WALL ANCHOR onto the “pre-installed” BOLT FOR CUBE and NUT assembly using the provided hardware (bolt, washers, and nut). Secure by firmly tightening the nut onto the bolt.

IMPORTANT NOTICE

- Wall anchors are strictly to connect a Candock system onto another type of **floating** dock.
- Connection point onto the other type of floating dock must provide a flat, sturdy, and robust surface from 10cm (4”) over the waterline up to 20cm (8”) to allow for the mounting plate to be securely fastened to the existing floating dock.
- If the existing dock's freeboard height is higher than the Candock system, include an EXTENSION PLATE FOR WALL ANCHORAGES, which provides additional leeway for adjusting the WALL ANCHOR proper height. The plate allows for a freeboard height of 60cm (24”) at the most.
- When purchasing the EXTENSION PLATE FOR WALL ANCHORS, the needed hardware to secure the WALL ANCHOR onto the plate is included in the packaging.
- Wall anchors are to be installed in pairs; or more.

A FEW EXAMPLES

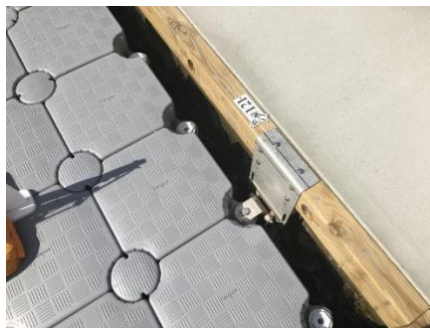
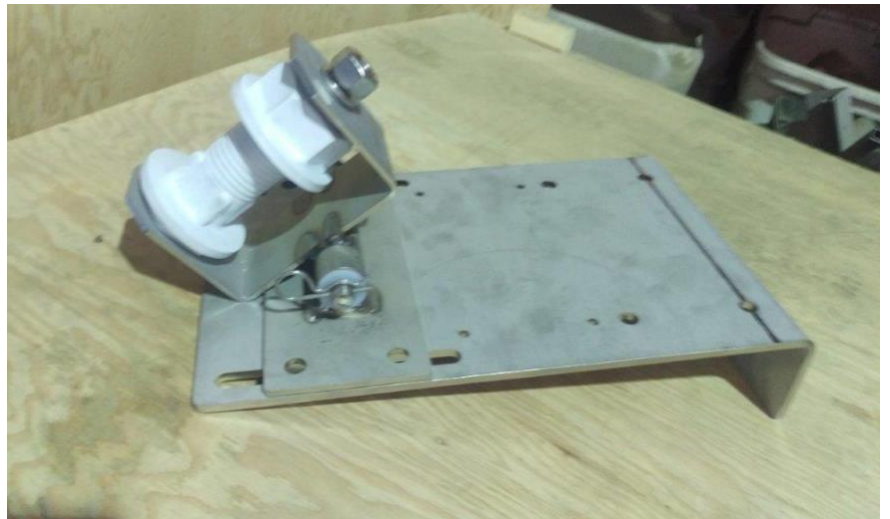

SWIVEL ANCHOR CHANNEL FOR JETROLL



SPECIFICATIONS

Material/Composition: Galvanized steel

Needed tools: 7/32" Allen Key and proper power tools and hardware to secure the "channel" on an existing floating structure.

SKU NUMBER

SWIVEL ANCHOR CHANNEL GALVANIZED STEEL: C07-000002

ASSEMBLY PROCEDURE

- 1-Secure the "claw" piece of the bracket onto the JetRoll using the provided hardware.
- 2-Determine adequate height of the "channel" piece onto the existing floating structure and firmly secure it using adequate hardware.
- 3-Link the 2 pieces of the bracket using the dowel and hairpin.

IMPORTANT NOTICE

- Swivel anchor channels are strictly to connect a JetRoll unit onto another type of **floating** dock.
- Connection point onto the other type of floating dock must provide a flat, sturdy, and robust surface to allow the "channel" to be securely fastened to the existing floating dock.
- Swivel anchor channels are to be installed in pairs.

SLIDING ANCHOR H-BEAM

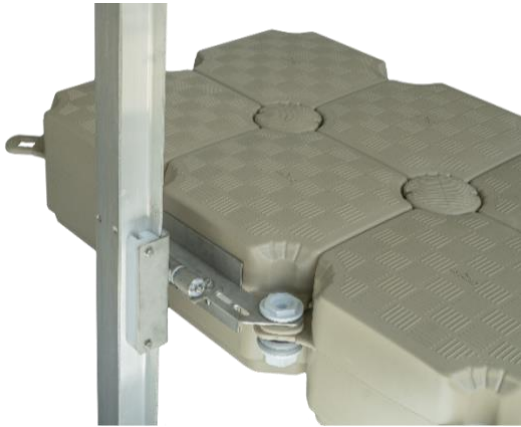

SPECIFICATIONS

Material/Composition: Aluminum and stainless steel 316 L

Dimensions: H-Beam length: 304.8cm (10')

Needed tools: Key for nut, $\frac{3}{4}$ " ratchet socket and wrench, and adapted tools and hardware to secure the "H" BEAM onto the shoreline structure

SKU NUMBER

SLIDING ANCHOR H-BEAM STAINLESS STEEL: C06-000006

SLIDING ANCHOR H-BEAM ALUMINUM: C06-000007

IMPORTANT PRINCIPLES

The below principles and notions apply to Candock's SLIDING ANCHOR H BEAM.

FLUCTUATION AMPLITUDES: We suggest installing SLIDING ANCHOR H BEAM that allows the fluctuation amplitudes of the environment it is installed in.

AT LEAST 60% OF THE OVERALL LENGTH OF THE H BEAM MUST BE SECURED ON THE SHORELINE'S STRUCTURE.

The bottom portion of the H Beam may not be possible to secure onto the face of the existing structure (seawall), but we recommend at least 60% of its length well secured onto the seawall.

VERTICALITY: All H beams should be perfectly vertical after installation is complete. The use of a level is highly recommended.

PROTECTED ENVIRONMENT: Any Candock system that is to be anchored with our SLIDING ANCHOR H-BEAM should not be subjected to waves of more than 60cm (2'). The Candock's piling system is extremely restrictive in the amount of leeway it will allow to the dock. Aggressive waters may translate to premature wear of the components.

CANDOCK'S SLIDING ANCHORAGE H-BEAM WORK IN PAIRS: Candock's H beam system implies that the beams are to be configured in pairs; or more.

A FEW EXAMPLES



◎ JETSLIDE DRY-DOCK SYSTEM

JETSLIDE SYSTEM BASIC CONCEPTS

The JETSLIDE dry-dock system consists of an assembly of multiple components. First and foremost, the JETSLIDE unit itself. It is the center part of any drive-on dry-dock system that Candock can provide. Depending on the vessel's size and specifications, an array of additional components is required to ensure a safe and efficient system.

The below information is essential information for every JETSLIDE SYSTEM that is to be considered/offered:

MAKE NAME (BRAND) – MODEL NAME – YEAR OF MANUFACTURING – ENGINE LAYOUT AND SPECIFICATIONS

Consisted of a single piece of medium density polyethylene, with 100% of its interior filled with expanded polystyrene, the JETSLIDE is virtually unsinkable. Furthermore, as it does not have any mobile parts, it relies on its “low friction” soft surface to help your vessel going up and down from the system itself.

Depending on the boat's length and weight, Candock will determine a suitable configuration of the needed components. JETSLIDE, CUBES, CONNECTING PINS, and SLIDING NUTS, to name a few, are all part of the recipe to create a perfectly tailored dry-dock system for your vessel.



There are some basic yet essential rules and premises to ensure a functional system:

- 1- CANDOCK'S PROPOSED CONFIGURATION SHOULDN'T BE ALTERED IN ANY WAYS.**
- 2- CERTAIN BOATS (STEPPED HULL, V-DRIVE/DIRECT-DRIVE) ARE NOT COMPATIBLE WITH THE JETSLIDE SYSTEM.**
- 3- USERS MUST MASTER MANEUVERS WITH SUCH A SYSTEM.**
- 4-CANDOCK IS NOT LIABLE FOR ANY DAMAGES RESULTING OF THE NON-COMPLIANCE OF THE FOLLOWING GUIDELINES.**

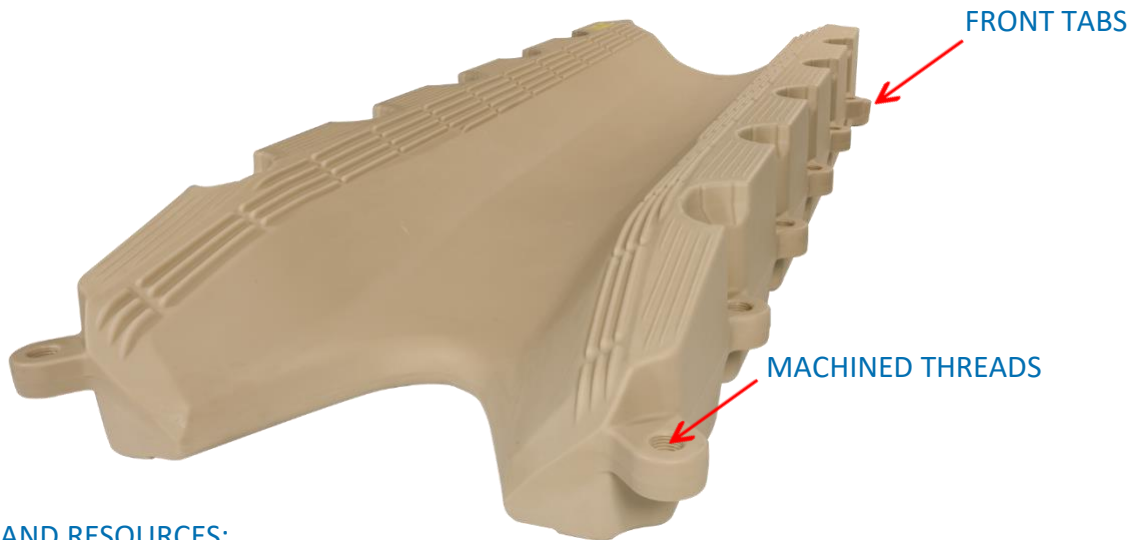

USEFUL LINKS AND RESOURCES:

[YouTube](#)

[Website](#)

TAB POSITIONS

	#6
	#5
	#4
	#3
	#2
	#1
	#0
	#-1

SPECIFICATIONS

Material/Composition: Medium-density polyethylene resin - RotoMolded

Available colors: Beige and Gray

Dimensions: L x W: 288 cm (114") x 96 cm (38") H: 38 cm (15")

Weight: 68 kg (150 lbs.)

Needed tools: G2 key for pin, Key for nut

SKU NUMBERS

G2 JETSLIDE BEIGE: C02-000015

G2 JETSLIDE GRAY: C02-000016

TERMINOLOGY

JETSLIDE TABS: Prominent threaded parts on each side of the JETSLIDE, located under tab "1" *. As opposed to our regular CUBE coupling system, which requires the addition of a SLIDING NUT at the bottom of a connection point so that the CONNECTING PIN can have traction in the threads, the JETSLIDE TABS have their threads inside the tabs along its sides.

*The exception to the above description is the FRONT TABS (left and right), located underneath the other JETSLIDE tabs. This specifically allows the merging of 2 JETSLIDES in an "in-line" configuration. This allows configuring longer systems to accept longer/heavier vessels. See lower in this section for more explanations on "dual" JETSLIDE configurations.

PLUGS: These watertight plugs are always found on the front wall of the JETSLIDE. These plugs, made of a breathable material, act as pressure release valves, preventing the JETSLIDE's deformation due to temperature changes and pressure variations. Furthermore, these plugs prevent any condensation inside the JETSLIDE.

OVERVIEW

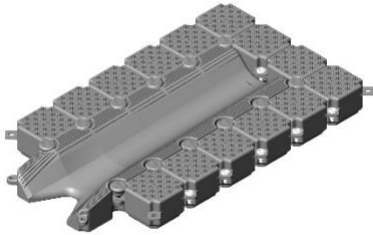

JETSLIDE SMALLEST CONFIGURATION (PWC)

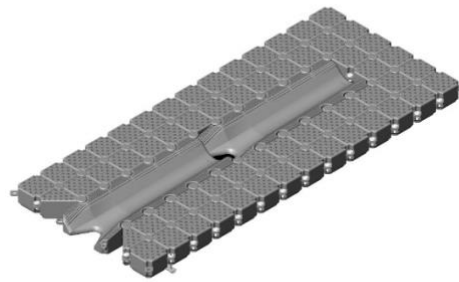

JETSLIDE BIGGEST CONFIGURATION (BOAT)

***THIS CONFIGURATION MAY NOT BE
SUITABLE FOR ALL BOATS***

ASSEMBLY PROCEDURE

PRIOR TO INSTALLATION

1-Assemble on a flat surface rather than in the water.

2-Assemble the cubes around the JETSLIDE. If you attach it to an existing Candock dock, make sure the plugs face the same direction as the existing dock. If your JETSLIDE is an independent unit, the cubes' vent plugs should be oriented towards the system's front.

PROCEDURE:

1-Prepare the needed SPACERS on each side of the JETSLIDE before manually inserting the connecting pins. The tab configuration will create a void in the assembly; depending on the cube's tabs utilized in the assembly, insert SPACERS in the missing tabs' opening.

2- Manually insert CONNECTING PINS to engage the threads.

3-When the pins are engaged, proceed by screwing manually or mechanically. Start by tightening the pins in the middle section of each side and work towards the front and the back **alternating**.

4-We suggest manually tightening the pins to better feel the needed torque for each CONNECTING PIN.

4) For the 2 front corners of the JETSLIDE connecting points, the CONNECTING PINS require SLIDING NUTS as the FRONT TABS are too low, and they don't have a threaded opening like the other tabs of the JETSLIDE. Insert a SLIDING NUT on the lowest tab available at the connection point and make sure to include the potentially needed SPACERS if the tab configuration creates a void in the assembly.

5) When the needed CUBES are all secured around the JETSLIDE, install BOLT FOR CUBE and NUTS assemblies all around the perimeter of the JETSLIDE system. Make sure to include the potentially needed SPACERS if the tab configuration creates a void in the assembly.

OPERATING A WATER-CRAFT WITH THE JETSLIDE

IMPORTANT NOTICE

The water depth at the back of the system (entry point) must be at least 1m (3.3') to avoid potential damage to the engine's propeller and skeg.

GOING UP THE SYSTEM

PWC: Approach the JETSLIDE at idle, keeping the craft straight and centered with the JETSLIDE. When the craft's bow is in contact with the JETSLIDE, give small throttle strokes to align the craft with the JETSLIDE. When the craft is in line with the JETSLIDE, throttle in slowly. After a few tries, you will develop a feel of how much throttle you must use to reach the final position on the JETSLIDE

BOAT: The engine must be trimmed entirely down during the entering procedures. Increase throttle power until the boat is entirely on the system. When the engine gets in contact with the JETSLIDE, you will feel the vessel has stopped. You must immediately throttle down. It indicates that the craft is at its final resting position. Entering the unit at high speed may damage the unit. We recommend, at first, that you try at slow speeds until you reach the correct speed. If the boat gets on the system but is not all the way in, you can continue throttling progressively until the boat reaches its final resting position. Be careful; boarding on the JETSLIDE at high speed can be dangerous.

NOTE: It is recommended to secure the craft to a cleat to prevent it from sliding back into the water accidentally. The craft can be locked to the JETSLIDE system with a CONNECTING PIN WITH LOCK CHAIN. See lower in this manual.

GOING DOWN THE SYSTEM

PWC: To go back into the water, initiate the procedure by pushing the PWC backward of 30-60cm (1' to 2') to bring the machine's weight towards the back of the system. Then, stand up at the back of your PWC, grab the seat's handle, and transfer your weight backward. The easiest way to push the PWC backward is to grab the PWC's nose in one hand and the handle with the other and then push gently. Be vigilant because, at some point, your PWC will want to go down by itself. At this point, you will have to get on it if you do not want it in the water without you.

BOAT: Trim the engine down completely and put the engine in reverse. Gradually increase throttle until craft starts to go down by itself. It helps if you wet the system, especially if the boat was not used for an extended period. It might be necessary to give a good throttle stroke to initiate the motion and then throttle down.

NOTE: For boats powered with turbine engine layout, a BOAT WINCH is required to initiate the process of going back in the water with the vessel. See lower in this manual.

WARNINGS & SPECIAL INSTRUCTIONS

- 1- For all JETSLIDE systems, the surrounding environments must not be subjected to waves of more than 60cm (24"). We recommend installing a JETSLIDE system in a protected area.
- 2-The installation of multiple PWC JETSLIDES side by side is possible, but we suggest a minimum of 2 rows of CUBES in-between each JETSLIDE. An installation with only one row is also possible, but there are risks of injuries for the surrounding users and damaging the PWC.
- 3-The lifting (crane) of multiple JETSLIDES assembled is strongly not recommended.
- 4-Aluminum riveted hulls may scratch the surface of the JETSLIDE.
- 5- "Stepped-hull" vessels as well as "v-drive or direct-drive" engine layouts are not compatible with the JETSLIDE system.
- 6-Please note that some boats have engine cooling intakes on the hull and may overheat if the boat is dry-docked on the system with the engine running.
- 7-All boats and PWC's must be brought entirely to the front of the JETSLIDE at all times.
- 8-Surfaces can be slippery when the system is wet.

STIFFENING BEAMS

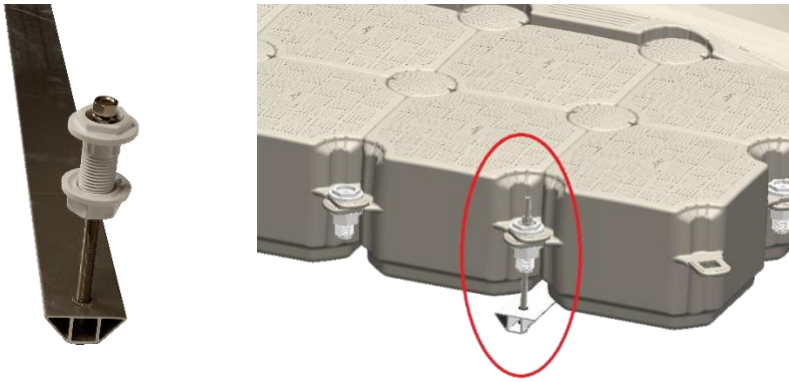

SPECIFICATIONS

Material/Composition: Aluminum and stainless-steel rods.
Needed tools: 1 1/8" ratchet socket and wrench
***Bolt for cube and nut NOT included.**

SKU NUMBERS

STIFFENING BEAM FOR JETSLIDE SYSTEM 115" (6 CUBES): C02-000006
STIFFENING BEAM FOR JETSLIDE SYSTEM 153" (8 CUBES): C02-000007

ASSEMBLY PROCEDURE

PRIOR TO INSTALLATION

- 1-Assemble STIFENING BEAMS when the JETSLIDE system is in the water.
- 2-Position STIFFENING BEAM(S) precisely at the designated position provided by your Candock's representative.

PROCEDURE

- 1-Insert the STIFFENING BEAM assembly onto "pre-installed" BOLT FOR CUBE and NUT assembly using the provided hardware (bolt, washers, and nut). Holding the threaded rods' very end, slide the beam underneath the system starting from the rear. Ensure installing the beams at the front and making your way to the back with the subsequent beams if needed.
- 2-Once aligned, secure the beam to the BOLT FOR CUBE with the hardware kit supplied with the bars. Insert the threaded rods through the BOLT FOR CUBE and manually engage the washers, lock washers, and nuts.
- 3-Complete installation by adjusting the beam's positions to be perfectly perpendicular to the JETSLIDE(S). The over-tightening of the stabilizer bars may exert undue pressure on the tabs and cause damages to the JETSLIDE(S).

TIP

-The number of STIFFENING BEAMS needed for a specific configuration may be estimated with the below ratio:

(1x) STIFFENING BEAM FOR EVERY 455kg (1000lbs) OF THE VESSEL'S WEIGHT.

Example: A boat of 910kg (2000lbs) "wet weight" requires (2x) STIFFENING BEAMS.

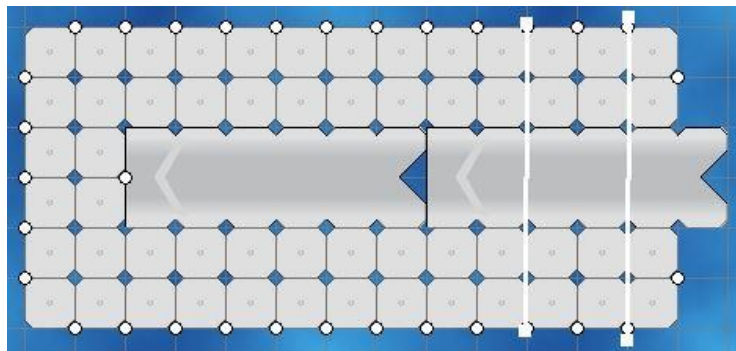

“V” PLATE

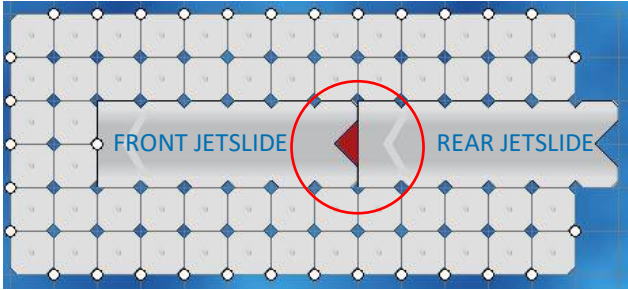

SPECIFICATIONS

Material/Composition: HDPE and stainless-steel hardware.
Needed tools: 7/32" Halen key

SKU NUMBER

V-PLATE: C02-000017

ASSEMBLY PROCEDURE

With an assembly of dual “inline” JETSLIDES, the connection point between the 2 JETSLIDES creates an opening at the “V-shaped” entry point of the front JETSLIDE. To cover this hazardous opening, you must install the V-PLATE, which is to be secured in place under the JETSLIDE with (6X) counter sunken Halen screws (provided) screwed into casted brass inserts.

PROCEDURE

1-Flip the JETSLIDE upside down and secure the V-PLATE with the provided hardware.

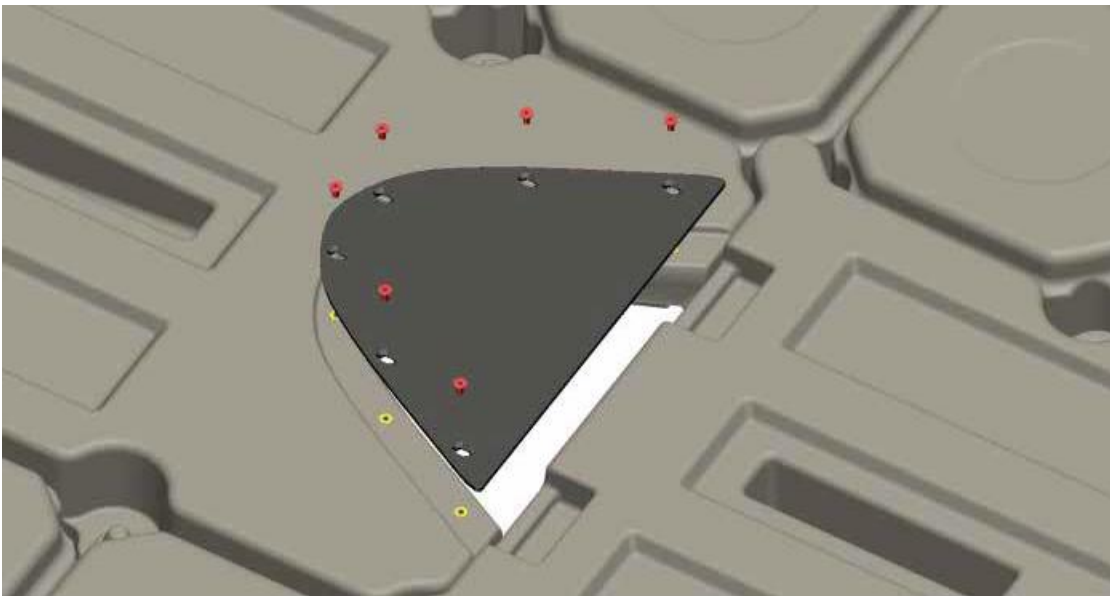

EXTENSION PLATES (1, 2, AND 3 CUBES) AND BOLTS FOR JETSLIDE

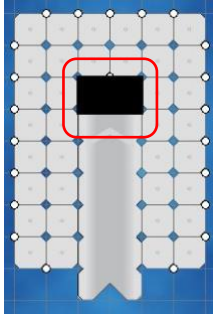

EXTENSION PLATE 1 CUBES

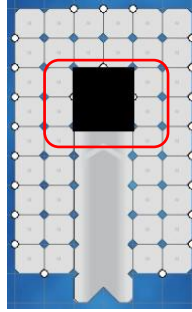

EXTENSION PLATE 2 CUBES

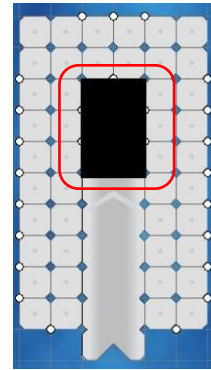

EXTENSION PLATE 3 CUBES

SPECIFICATIONS

Material/Composition: HDPE and stainless-steel hardware.

Needed tools: Key for nut

*Bolts for JETSLIDE and sliding nuts not included.

SKU NUMBER

EXTENSION PLATE 1 CUBE: C02-000018

EXTENSION PLATE 2 CUBES: C02-000019

EXTENSION PLATE 3 CUBES: C02-000020

BOLT FOR JETSLIDE: C02-000001

ASSEMBLY PROCEDURE

The EXTENSION PLATES, available in 3 different sizes, are used to accommodate intermediary boat lengths as opposed to including a second JETSLIDE (in a dual “in-line” configuration) Precisely adapting the overall size of the system needed for a specific boat while keeping the cost as low as possible. To secure the EXTENSION PLATE, we use modified BOLTS FOR CUBE to remove the “locking ribs.” It allows for the BOLTS FOR CUBE to be used as regular “bolts.” When modified, these bolts are named BOLT FOR JETSLIDE.

*Once installed, the plate may slightly deform. This deformation is expected and normal.

**Please note that the surface of the safety plate can be slippery.

PROCEDURE

- 1- Insert SLIDING NUT on all cube tabs that are supporting the EXTENSION PLATE.
- 2- Place all needed SPACERS if the tab configuration creates a void in the assembly, starting from the lowest available tab to the highest. Make sure the EXTENSION PLATE is leveled.
- 3- Gently put the EXTENSION PLATE without moving the spacers.
- 4- Manually engage the BOLT FOR JETSLIDE into the SLIDING NUTS.
- 5- Firmly tighten the BOLT FOR JETSLIDE, ideally with a RATCHET key for nut.



JETSLIDE BOAT WINCHES

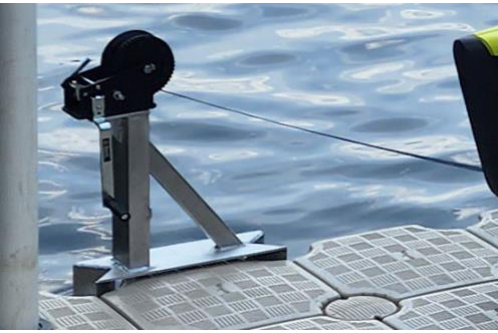

SPECIFICATIONS

Material/Composition: Aluminum and galvanized steel or stainless steel 316
Needed tools: Key for nut and 1 1/8" ratchet socket and wrench
***Bolt for cube and nuts included.**

SKU NUMBERS

WINCH JETSLIDE FOR BOAT (ALUMINUM): C02-000021
WINCH JETSLIDE FOR BOAT (STAINLESS STEEL): C02-000022

ASSEMBLY PROCEDURE

The purpose of the JETSLIDE BOAT WINCH is mainly to initiate the "unberthing" maneuvers of turbine/jet engine vessels when users want to get their boats back in the water from a fully dry-docked position.

Position the JETSLIDE BOAT WINCH and PULLEY exactly at the designated position provided by your Candock's representative.

PROCEDURE

- 1-Install the JETSLIDE BOAT WINCH with the provided BOLT FOR CUBE and NUTS
- 2-Once the winch is installed, insert the pulley and connecting ring assembly onto the "pre-installed" BOLT FOR CUBE and NUT assembly using the provided hardware.
- 3-Complete installation funneling the rope from the winch through the pulley and back towards the vessel's front.

IMPORTANT NOTICE

-Maximal boat weight capacity of the JETSLIDE BOAT WINCHES is 1360kg (3000lbs)

Candock does not recommend using the winch and its components to complete your vessel's "berthing maneuvers." do not use the winch to pull your boat onto the JETSLIDE system.

JETSLIDE PWC WINCH



SPECIFICATIONS

Material/Composition: Stainless steel 316 and plastic handle

SKU NUMBER
JETSLIDE PWC WINCH: C02-000023

ASSEMBLY PROCEDURE

The purpose of JETSLIDE PWC WINCH is mainly to initiate the “unberthing” maneuvers of turbine/jet engine PWC when users need help putting their PWC back in the water from a fully dry-docked position.

Position the JETSLIDE PWC WINCH exactly at the designated position provided by your Candock’s representative.

PROCEDURE

- 1- Remove the regular CONNECTING PIN that is at the designated location.
- 2-Install the JETSLIDE PWC WINCH by manually screwing it in place.

IMPORTANT NOTICE

-Maximal PWC weight capacity of the JETSLIDE PWC WINCH is 500kg (1100lbs)

-Candock does not recommend using the winch and its components to complete the “berthing maneuvers” of your PWC. Do not use the winch to pull your PWC onto the JETSLIDE system.

CONNECTING PIN WITH LOCK CHAIN



SPECIFICATIONS

Material/Composition: HDPE, concrete, and 40cm (16") stainless steel chain section
Available colors: Beige and Gray

SKU NUMBER

CONCRETE FILLED CONNECTING PIN G2 WITH SAFETY CHAIN - BEIGE: C03-000045
CONCRETE FILLED CONNECTING PIN G2 WITH SAFETY CHAIN - GRAY: C03-000046

ASSEMBLY PROCEDURE

- 1-Establish the location of the future CONNECTING PIN WITH LOCK CHAIN on the dock.
- 2-Remove the CONNECTING PIN that is at the desired location.
- 3-Insert the CONNECTING PIN WITH LOCK CHAIN and complete the screwing process by hand.

PWC JETSLIDE SYSTEM CONFIGURATION GUIDELINES

The following section is also essential to Candock. **The configuration of a PWC Jetslide system is of the utmost importance to ensure its optimal durability and performance.** Following the below recommendations and guidelines is critical for your product to perform as we intend.

There are several sizes and models, so the below configurations may have to be modified on a case-by-case basis. Please contact a Candock representative in the event you wish to alter the below configurations.

1 – IDEAL CONFIGURATION

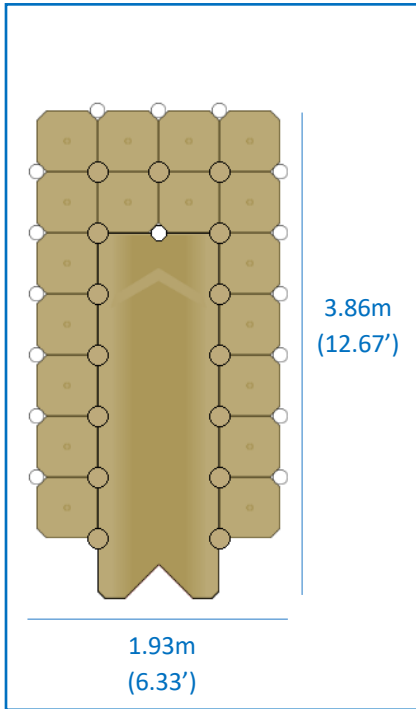

2 – ALTERNATE CONFIGURATION

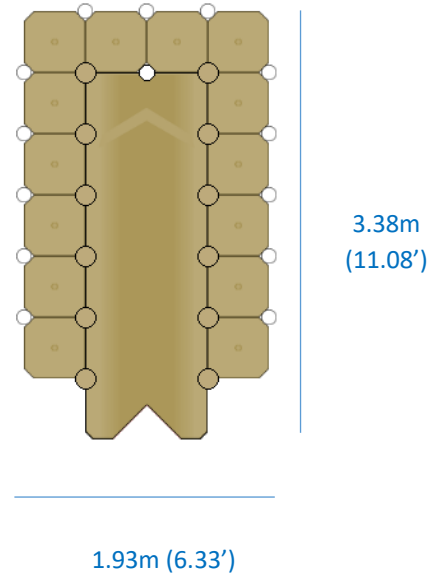

IMPORTANT NOTIONS

-Always keep the system symmetrical left/right.

-In doubt, please refer to your Candock representative.

-For multiple units assembled, we advocate **2 rows of cubes in between each JETSLIDE**. Using only 1 row of cubes between each JETSLIDE is also possible but be aware of possible injuries or machine damages. As space between the machines is limited, there are potential risks of impacts with surrounding objects or users.

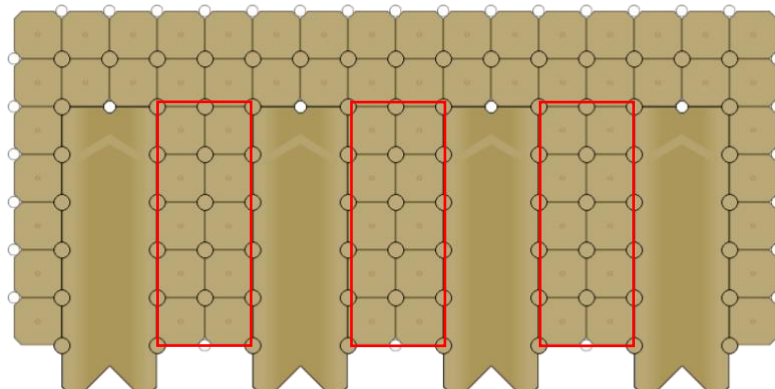

PWC JETSLIDE SYSTEM ANCHORING GUIDELINES

The following configurations are showcased to help determine the best scenario for each situation. Numerous factors influence the exact suggested layout, so the following proposed layouts must not be taken integrally. Modifications and altering of these are highly probable. Please contact a Candock representative to gather clarification and validation on the below configurations.

The below section is segmented as per our anchoring accessories/techniques categories. Note that combinations of multiple techniques may apply, and some alterations of the below accessories/techniques may also be involved in the process. The below list aims at covering as many of the possible scenarios. If the JetSlide system is secured against another floating or fixed structure (another Candock system, a standard floating dock, a fixed dock, or seawall), this "other" structure must be adequately anchored or fixed in place to withstand the torque applied by the addition of the JetSlide system.

It is also probable that in the event of a regular "POST CUBE AND PILES" anchoring technique, additional accessories may be required to secure the piles' upper section onto another fixed structure. In this case, the POST CUBES location may be changed to accommodate the needed bracket and hardware. Additionally, the POST CUBES may also be substituted with our HDPE PILE GUIDE FOR 2 7/8 " STEEL PILE if the situation allows.

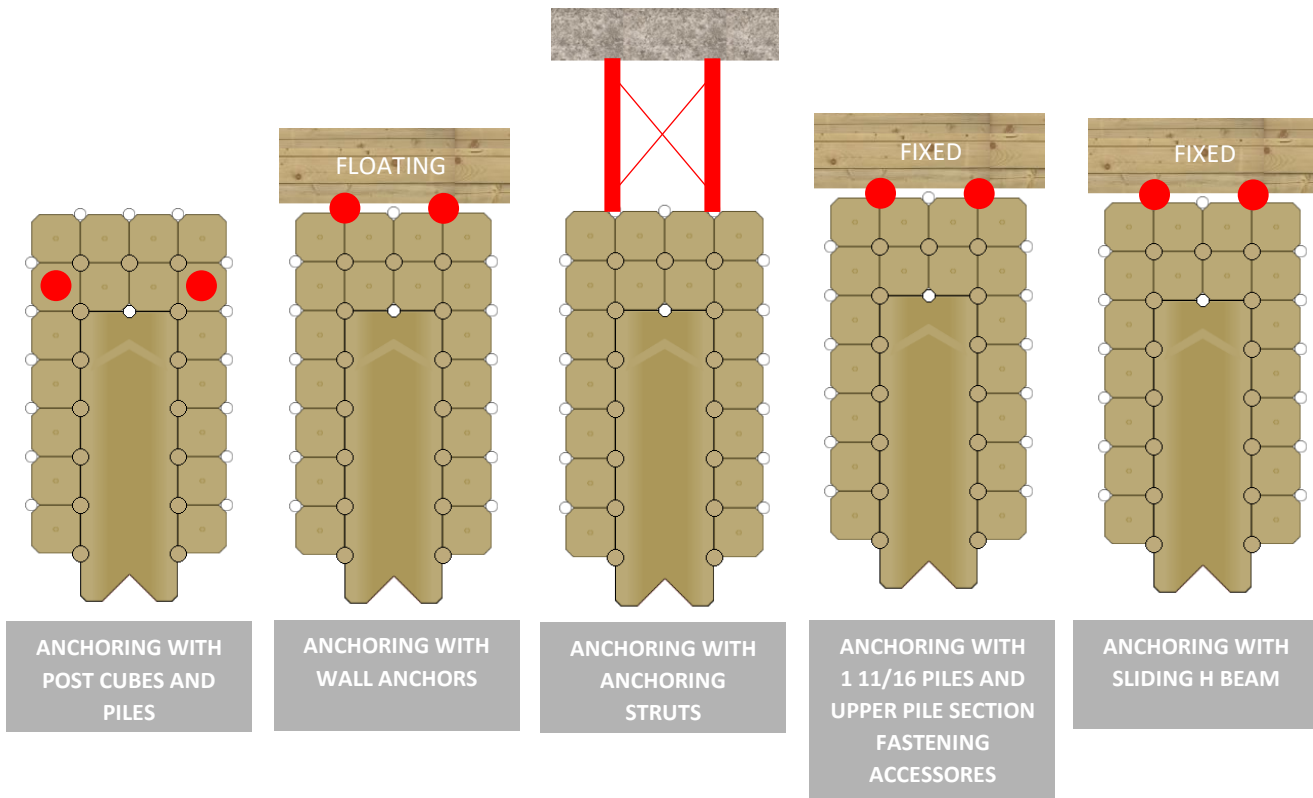

A FEW EXAMPLES

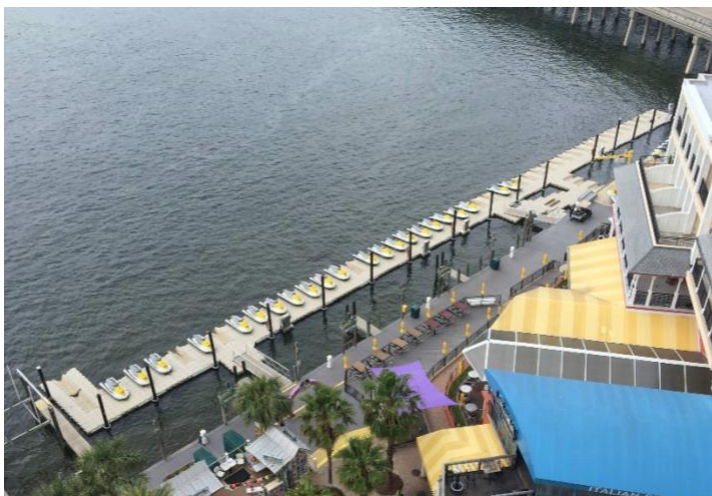

BOAT JETSLIDE SYSTEM CONFIGURATION GUIDELINES

The following section is also essential to Candock. **Indeed, the configuration of a BOAT Jetslide system is of the utmost importance to ensure its optimal durability and performance.** Following the below recommendations and guidelines is vital for your product to perform as we intend.

There are several sizes and models, so the below configurations may have to be modified on a case-by-case basis. Please contact a Candock representative to help in determining a valid and approved configuration for your vessel.

To better help our customers, we have elaborated a comprehensive chart that helps determine a specific vessel's needed layout while considering the 2 most important variables, length, and weight.

IMPORTANT NOTICES

- Maximal boat's weight capacity of Candock's JETSLIDE system is 1360kg (3000lbs), including hull, engine, fuel, and equipment.
- Vessels with V-Drive and Direct-Drive engine layouts are not compatible with the JETSLIDE's system.
- Vessels with "step-hull" designs are not compatible with the JETSLIDE's system.
- Pontoon boats are not compatible with the JETSLIDE's system.

A FEW EXAMPLES



◎ JETROLL DRY-DOCK SYSTEM

JETROLL SYSTEM BASIC CONCEPTS

The JETROLL dry-dock system is a single-piece unit that is specially designed to accommodate PWC's.

Consisted of a single piece of medium density polyethylene, with 100% of its interior filled with expanded polystyrene, the JETROLL is virtually unsinkable. In opposition with the JETSLIDE, the JETROLL is equipped with 12 nylon wheels on stainless steel shafts, allowing for even easier berthing and unberthing maneuvers. Furthermore, as it requires virtually no assembly, it offers advantages that are not to be neglected.

Depending on the environment and the PWC, Candock will determine the proper anchoring layout.



There are some basic yet, essential rules and premises to ensure a functional system:

- 1- CANDOCK'S PROPOSED ANCHORING CONFIGURATION SHOULDN'T BE ALTERED IN ANY WAYS.**
- 2- USERS MUST MASTER MANEUVERS IMPLIED WITH SUCH A SYSTEM.**
- 3-CANDOCK IS NOT LIABLE FOR ANY DAMAGES RESULTING OF THE NON-COMPLIANCE OF THE FOLLOWING GUIDELINES.**

JETROLL (BOW-STOP, HOLE CAPS, AND WHEELS)



TAB POSITIONS

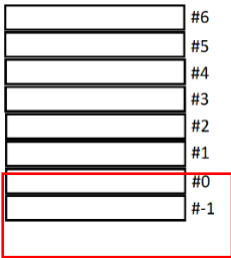

SPECIFICATIONS

Material/Composition: Medium-density polyethylene resin – Roto-molded
Available colors: Beige and Gray
Dimensions: L x W: 386 cm (152") x 193 cm (76") H: 30.5cm (12")
Weight: 159 kg (350 lbs.)
Needed tools: G2 key for pin, Key for nut, rubber mallet, 7/32" Halen key

[YouTube](#)

SKU NUMBERS

JETROLL BASIC KIT BEIGE: C02-000013
JETROLL BASIC KIT GRAY: C02-000014
BOW-STOP BEIGE: C02-000008
BOW-STOP GRAY: C02-000009
HOLE CAP BEIGE: C02-000010
HOLE CAP GRAY: C02-000011
WHEELS KIT: C02-000012

TERMINOLOGY

JETROLL TABS: (4x) prominent threaded openings that are on the front of the JETROLL; which are located under tab "0" and under "-2". The 2 outside tabs are the lowest (under "-2"), and the 2 center ones are the highest (under "0"). This particularity allows for our EDGE cubes to be merged at the front of the JETROLL. As opposed to our regular CUBE coupling system, which requires the addition of a SLIDING NUT at the bottom of a connection point so that the CONNECTING PIN can have traction in the threads, the JETROLL also has its threads inside the tabs.

PLUGS: These watertight plugs are always found in the front part of the JETROLL. These plugs, made of a breathable material, act as pressure release valves preventing JETROLL's deformation due to temperature changes and pressure variations. Furthermore, these plugs prevent any condensation inside the JETROLL.

WHEELS & PLASTIC WASHERS: (12x) plastic and polyurethane wheels and (24x) nylon washers that can be positioned in numerous configurations to ensure an optimal fit with any PWC on the market. Include (1x) small nylon washer on each side of each wheel for a total of (24x) for each JetRoll.

SHAFTS: (12x) stainless shafts that allow for smooth rolling motion of the wheels.

BOW-STOP: Molded plastic piece positioned at the front of the JETROLL to help prevent the PWC from exceeding the front of the system during berthing maneuvers.

HOLE CAP: A molded plastic piece that can be “snapped-on” into the circular openings on the 4 corners of the JETROLL. Depending on the adequate anchoring layout and accessories, these are to be inserted in the remaining openings to prevent a trip hazard.

OVERVIEW



ASSEMBLY PROCEDURE

PRIOR TO INSTALLATION

1-Assemble on a flat surface rather than on the water.

PROCEDURE:

1-Prepare the needed parts around your JETROLL (2 HOLE CAPS, 1 BOW-STOP, and 12 WHEELS AND SHAFTS).

2-Determine the location of the 12 wheels. Ideally, Candock suggests using the featured pre-set (above image). The goal is to create a lower area to create a cradle for the machine to rest in the system's middle. Especially after/during berthing maneuvers, this lower-center geometry is to prevent the PWC from rolling back in the water by itself.

3-Using the rubber mallet, hammer down on the wheel and shaft assembly with a single stroke motion, directly on the wheel.

4-Secure the BOW-STOP using the provided hardware. Brass inserts are already casted in the plastic of the unit.

5- If needed, using the rubber mallet, hammer down HOLE-CAPS in the proper locations.

OPERATING A WATER-CRAFT WITH THE JETROLL

IMPORTANT NOTICE

The water depth at the back of the JETROLL must be at least 1m (3.3') to avoid potential damage to the PWC turbine.

GOING UP THE SYSTEM

Approach the JETROLL at idle, keeping the craft straight and centered with the JETROLL. When the craft's bow is in contact with the JETROLL, give small throttle strokes to make the craft align with the JETROLL. When the craft is in line with the JETROLL, throttle in slowly. After a few tries, you will develop a feel of how much throttle you must use to reach the final position on the JETROLL.

NOTE: It is recommended to secure the craft to the BOW-STOP's eyelet to prevent the PWC from rolling back into the water accidentally.

GOING DOWN THE SYSTEM

To go back into the water, initiate the procedure by pushing the PWC backward of 30-60cm (1' to 2') to bring the machine's weight towards the back of the system. Then, stand up at the back of your PWC, grab the seat's handle, and transfer your weight backward. The easiest way to push the PWC backward is to grab the PWC's nose in one hand and the handle with the other and then push gently. Be vigilant because, at some point, your PWC will want to go down by itself. At this point, you will have to promptly get on the machine if you do not want your watercraft in the water without you.

WARNINGS & SPECIAL INSTRUCTIONS

1- For all JETROLL systems, the surrounding environments must not be subjected to waves of more than 60cm (24"). We recommend installing a JETROLL system in a protected area.

2-Surfaces can be slippery when the system is wet.

3-All PWC's must be brought entirely to the front of the JETSLIDE at all times.

LINK-KITS



SPECIFICATIONS

Material/Composition: HDPE and SS 316 L
Available colors: Beige and Gray
Needed tools: 15/16" ratchet socket and wrench

SKU NUMBERS

LINK KIT BEIGE: C02-000024
LINK KIT GRAY: C02-000025

TERMINOLOGY

UPPER LINK: Rotomolded plastic piece that fills the voids of the piling openings on the JETROLLS.

THREADED ROD AND HARDWARE: SS 316 and brass hardware to link the upper and lower link parts together.

LOWER LINK: HDPE plate fitted underneath the Jetroll allows for a complete assembly of the LINK KIT.

OVERVIEW

The addition of LINK KITS between multiple JETROLLS may be suggested or mandatory depending on the environment and conditions the systems are to be installed in. Please refer to your Candock distributor to know if LINK KITS should be included on your system. The addition of LINK KITS provides a stiffer assembly and prevents the JETROLLS from moving/sinking independently.

ASSEMBLY PROCEDURE

PRIOR TO INSTALLATION

Position the JETROLLS in the water at their final location before installing the LINK KITS

One person should be standing on the JETROLLS with one tool, and the other person should be in the water with the other tool to hold the "bottom" hardware.

PROCEDURE:

1-Position the upper and lower links onto the JETROLL connection point.



2-Insert threaded rods with washers from the top.

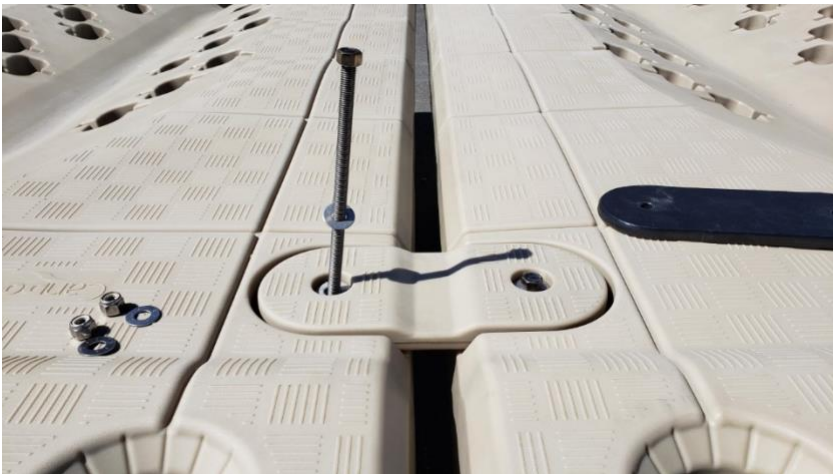

3-Place and hold the lower link underneath the JETROLLS



4-Insert the lower hardware and hold it in place while the person on the JETROLLS screws the threaded rod in place.



EXTENDED CONNECTING PINS FOR JETROLL



SPECIFICATIONS

Material/Composition: High-density polyethylene

Available colors: Beige and Gray

Dimensions: L :26.6cm x W: 17.2 cm (6.88”) / Shaft diameter : 4.547 cm (1.819”)

Weight: 377g

Needed tools: G2 key for pin

SKU NUMBERS

EXTENDED CONNECTING PIN BEIGE: C02-000002

EXTENDED CONNECTING PIN GRAY: C02-000004

TERMINOLOGY

HEAD: Upper part of the CONNECTING PINS designed with a flat and anti-skid surface.

NOTCH: Manufactured recess in the pin’s head that allows the tool to insert the key for screwing and unscrewing.

SHAFT: The male part of our coupling system, the extended threaded shaft, is inserted in the JETROLL’s front tabs.

ASSEMBLY PROCEDURE

1-Initiate the rotating process by hand.

2-When the CONNECTING PIN has access to the JETROLL’s tab threads, proceed by screwing manually or mechanically with the proper tools.

3-Make sure to securely tighten the CONNECTING PINS until snug, without over-tightening them.

TIPS

1-When initially inserting the CONNECTING PINS in place, you might want to firmly “tap” the pin in place. Ensure a firm “initial” grip of the shaft threads into the tabs. This “tap” helps you get the pin through the cube’s tabs resting on top of the JETROLL’s tabs.

2-Once the assembly process is completed, align the NOTCHES of the CONNECTING PINS using the manual key. This simple operation allows to quickly locate any CONNECTING PINS which could have unscrewed over time.

3-Always proceed with caution if using a power drill to fasten the CONNECTING PINS; the drill can tend to “kick”. Use protective footwear. If using a power drill to unscrew pins, always loosen-up the pins manually before using the drill.

4- Never use an “impact tool” to fasten the connecting pins as you will most likely damage the connecting pins as well as the assembly key for drill.

PWC JETROLL SYSTEM CONFIGURATION GUIDELINES

The following section is also essential to Candock. **The configuration of a PWC JetRoll system is of the utmost importance to ensure its optimal durability and performance.** Following the below recommendations and guidelines is vital for your product to perform as we intend.

There are several sizes and models of PWCs, so the below configurations may have to be modified on a case-by-case basis. Please contact a Candock representative in the event you wish to alter the below configurations.

IMPORTANT NOTIONS

- Always keep the rear (entry point) of the JETROLL free for it to sink freely when the PWC is climbing onto the system.
- For multiple units assembled, LINK KITS may or may not be suggested. The overall exposure and application influence the inclusion or exclusion of LINK KITS. Always refer to your Candock representative for guidance.
- Upon completion of an installation, HOLE CAPS or LINK KITS are mandatory in all 4 pile openings of the JETROLL(s) to ensure a safe and “trip-hazard-free” environment.
- BOW STOPS are mandatory on all JETROLL installations
- The inclusion of 12 wheels is mandatory on all JETROLL installations
- The ideal wheel configuration may vary depending on the hull’s shape and machine size.

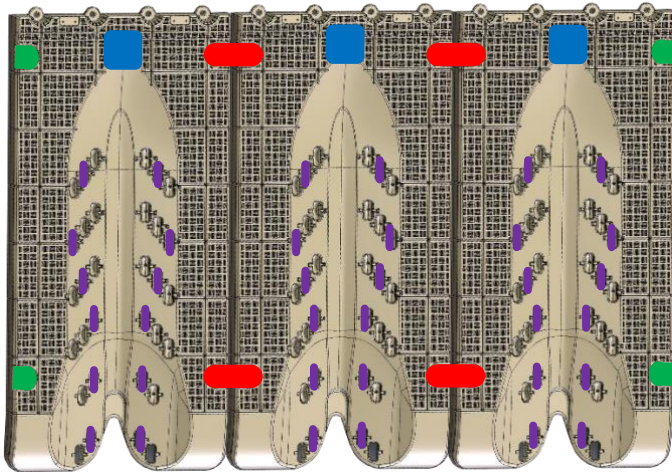

PWC JETROLL SYSTEM ANCHORING GUIDELINES

The following configurations are showcased to help determine the best scenario for each situation. There are several factors that influence the exact suggested layout. The following proposed layouts must not be taken integrally. Modifications and altering of these are highly probable. Please contact a Candock representative to gather clarification and validation on the below configurations.

The below section is segmented as per our anchoring accessories/techniques categories. Note that combinations of multiple techniques may or may not apply, and some alterations of the below accessories/techniques may also be involved in the process. The below list aims at covering as many of the possible scenarios. If the JetRoll system is secured against another floating or fixed structure (another Candock system, a regular floating dock, a fixed dock, or seawall), this “other” structure must be adequately anchored or fixed in place to withstand the torque that the addition of the JetRoll will apply.

	FIXED	FLOATING	FIXED	CANDOCK
STAND ALONE ANCHORING WITH PILES & PVC SLEEVES	ANCHORING WITH 2 7/8" STEEL PILES + PVC SLEEVES AND UPPER PILE SECTION FASTENING ACCESSORIES	ANCHORING WITH SWIVEL ANCHOR CHANNELS	ANCHORING WITH ANCHORING STRUTS (LENGTH 5' MAX)	CONNECTED TO A CANDOCK WITH (4X) EXTENDED CONNECTING PINS + (12x) SPACERS

GANGWAYS BASIC CONCEPTS AND CONFIGURATION GUIDELINES

The Candock aluminum access ramps (gangways) allows for a tailored transition passage from your shoreline to your Candock system. All our gangways consist of an assembly of multiple components. A proper analysis of the environment, the dock's application, and your specific needs and requirements will determine the gangway configuration and its components. Please contact a Candock representative for more information.

Several widths, lengths, and gages are available to suit most of the possible scenarios.

The categories of accessories can be classified as follow:

1-SHORE-END ACCESSORIES

2-GANGWAY FRAMES AND RAMP ACCESSORIES

3-DOCK-END ACCESSORIES



The following rules are fundamental to abide by to ensure the optimal efficiency and durability of your gangway:

1- A GANGWAY SHOULD NEVER BE STRONGLY SECURED AT BOTH ENDS (SHORE-END AND DOCK-END)

2- THE SHORE-END CONNECTING POINT OF ANY GIVEN GANGWAY SHOULD BE HIGHER THAN THE HIGHEST POSSIBLE WATER LEVEL.

3- TO KEEP A MODERATE DOWN SLOPE, THE LENGTH OF ANY GIVEN GANGWAY SHOULD BE AT LEAST 3 TIMES THE VERTICAL DEPRESSION/DROP IT HAS TO COVER

GANGWAY FRAMES (TRADITIONNAL AND MODULAR)



SPECIFICATIONS

Material/Composition: 6005 T-61 Marine grade aluminum

Specifications: See our GANGWAY SPECIFICATION CHART

Needed tools: Rubber mallet and, 7/16" ratchet socket and wrench for the modular models

***Included tools MODULAR FRAMES:** #3 Robertson drill bit (square), 3/16" drill bit, and all the needed hardware

AVAILABLE CATEGORIES

WELDED FRAMES: Consisted of an entirely welded assembly, our WELDED FRAMES are made with 5.08cm x 12.70cm (2" x 5") extrusion profiles. They are usually preferred for rugged residential applications or commercial/industrial applications. They are the most robust frames available at Candock. See below the SKU list for available dimensions.

MODULAR FRAMES: Consisted of an entirely modular assembly. Our MODULAR FRAMES are made with 3.49cm x 8.57cm (1.375" x 3.375") extrusion profiles. They are usually preferred for light-duty residential applications. The longest model we offer is 3.60m (12') long. As the frames are not assembled when shipped, they offer a significant advantage by generating considerable savings on shipping costs. See below the SKU list for available dimensions. **All components are to be bolted and screwed together after delivery at the customer's place.**

ASSEMBLY PROCEDURE - THE MODULAR GANGWAY FRAMES

See instruction video:

https://www.youtube.com/watch?v=vH6dv8J0c9g&list=PLmLmDtH9FZgCJBbUSVaBxIWi_7XCzh6H2&index=7

SKU NUMBERS

WELDED GANGWAY FRAME 90cm X 360cm (3' X 12'): C05-000026
WELDED GANGWAY FRAME 90cm X 480cm (3' X 16'): C05-000027
WELDED GANGWAY FRAME 90cm X 600cm (3' X 20'): C05-000028
WELDED GANGWAY FRAME 120cm X 360cm (4' X 12'): C05-000029
WELDED GANGWAY FRAME 120cm X 480cm (4' X 16'): C05-000030
WELDED GANGWAY FRAME 120cm X 600cm (4' X 20'): C05-000031
MODULAR GANGWAY FRAME 90cm X 120cm (3' X 4'): C05-000008
MODULAR GANGWAY FRAME 90cm X 240cm (3' X 8'): C05-000009
MODULAR GANGWAY FRAME 90cm X 360cm (3' X 12'): C05-000007
MODULAR GANGWAY FRAME 120cm X 120cm (4' X 4'): C05-000011
MODULAR GANGWAY FRAME 120cm X 240cm (4' X 8'): C05-000012
MODULAR GANGWAY FRAME 120cm X 360cm (4' X 12'): C05-000010

GANGWAY SPECIFICATION CHART

MODULAR FRAMES			
DIMENSIONS (ft)	MAX LOAD LBS.	MAX LOAD KGS	MAX OCCUPANCY (PEOPLE)
3X4 MODULAR	700	317	4
3X8 MODULAR	525	238	3
3X12 MODULAR	350	160	2
4X4 MODULAR	700	317	4
4X8 MODULAR	525	238	3
4X12 MODULAR	350	160	2

WELDED FRAMES			
DIMENSIONS (ft)	MAX LOAD LBS.	MAX LOAD KGS	MAX OCCUPANCY (PEOPLE)
3X12 FRAME	1750	795	10
3X16 FRAME	1750	795	10
3X20 FRAME	1750	795	10
4X12 FRAME	1750	795	10
4X16 FRAME	1750	795	10
4X20 FRAME	1750	795	10

RAILINGS (TRADITIONNAL AND MODULAR)



SPECIFICATIONS

Material/Composition: 6005 T-61 Marine-grade aluminum and stainless-steel hardware

Specifications: Height: 106.6cm (42"); for specifications, see our GANGWAY SPECIFICATION CHART

SKU NUMBERS

RAILING FOR WELDED GANGWAY 42in x 12ft: C05-000020

MODULAR RAILINGS – 1 SIDE – 240cm (8’): C05-000019

MODULAR RAILINGS – 1 SIDE – 360cm (12’): C05-000018

AVAILABLE CATEGORIES

RAILING FOR WELDED GANGWAY: Consisted of an entirely welded assembly that is bolted onto our WELDED GANGWAY FRAMES. Our RAILINGS provide additional strength and stiffness to our gangways while adding a safety factor for the pedestrians. They are usually preferred for rugged residential applications or commercial applications. **Assembly required.**

MODULAR RAILINGS: Consisted of an entirely modular railing assembly, MODULAR RAILINGS provide an added safety factor for the pedestrians. They are usually preferred for light-duty residential applications. As the railings are not assembled when shipped, they offer a significant advantage by generating considerable savings on shipping costs. See below the SKU list for available models. **All components are to be bolted and screwed together after delivery at the customer’s place.**

ASSEMBLY PROCEDURE - THE MODULAR GANGWAY RAILINGS

See instruction video:

https://www.youtube.com/watch?v=3ka9MAqze28&list=PLmLmDtH9FZgCJBbUSVaBxIWj_7XCzh6H2&index=10&t=134s

DEPARTURE ANGLES (TRADITIONAL AND MODULAR)



SPECIFICATIONS

Material/Composition: 6005 T-61 Marine grade aluminum, UHMW bushings, and stainless-steel hardware

Needed tools: 9/16" ratchet socket and wrench for the WELDED, 5/16" Halen key for the modular models, and proper tools and hardware to secure the 90 degrees profile onto the existing shoreline structure (seawall, fixed dock, etc.).

SKU NUMBERS

WELDED GANGWAY FRAME DEPARTURE ANGLE 90cm (3') : C05-000003

WELDED GANGWAY FRAME DEPARTURE ANGLE 120cm (4') : C05-000004

MODULAR GANGWAY FRAME DEPARTURE ANGLE 90cm (3') : C05-000005

MODULAR GANGWAY FRAME DEPARTURE ANGLE 120cm (4') : C05-000006

AVAILABLE CATEGORIES

WELDED GANGWAY FRAME DEPARTURE ANGLE: Consisted of an entirely welded assembly that is bolted onto our WELDED GANGWAY FRAMES. Our WELDED DEPARTURE ANGLES pivot system allows for smooth movement of the gangway to follow the fluctuations of the water levels. They are usually preferred for rugged residential applications or commercial applications. See above the SKU list for available models. **Assembly required.**

MODULAR DEPARTURE ANGLE: Consisted of an entirely modular departure angle assembly, our MODULAR DEPARTURE ANGLES pivot system allows for smooth upwards and downwards movements of the gangway to follow the fluctuations of the water levels. They are usually preferred for light-duty residential applications. As the departure angles are not assembled when shipped, they offer a significant advantage by generating considerable savings on shipping costs. See below the SKU list for available models. **All components are to be bolted and screwed together after delivery at the customer's place.**

ASSEMBLY PROCEDURE - THE MODULAR GANGWAY DEPARTURE ANGLES

See instruction video:

https://www.youtube.com/watch?v=MPIWii0-r7Y&list=PLmLmDtH9FZgCJBbUSVaBxIWi_7XCzh6H2&index=9&t=4s

MODULAR HINGED LINK KITS

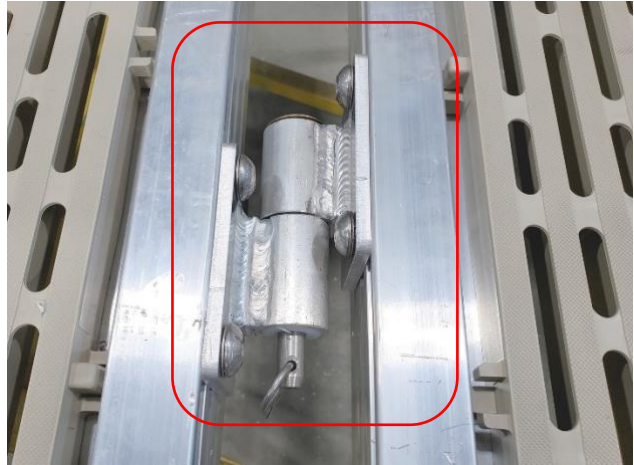

SPECIFICATIONS

Material/Composition: 6005 T-61 Marine grade aluminum, UHMW bushings, and stainless-steel hardware

Needed tools: 5/16" Halen key.

*Hardware is included

SKU NUMBERS

MODULAR HINGED LINK KIT (PAIR): C05-000013

DESCRIPTION

Utilizing the same pivot system as our DEPARTURE ANGLES, the HINGED LINK KITS allow the merging of two (2) gangways, often the first one being fixed; and the second one going down to the floating dock, allowing for a longer transition from shore to dock while keeping the gangways at reasonable dimensions.

They are preferred for light-duty residential applications. **Assembly required.**

ASSEMBLY PROCEDURE - THE MODULAR GANGWAY HINGED LINK KITS

See instruction video:

https://www.youtube.com/watch?v=MPIWii0-r7Y&list=PLmLmDtH9FZgCJBbUSVaBxIWi_7XCzh6H2&index=9&t=45s

SHORE-END PILE BRACKETS (WELDED AND MODULAR)

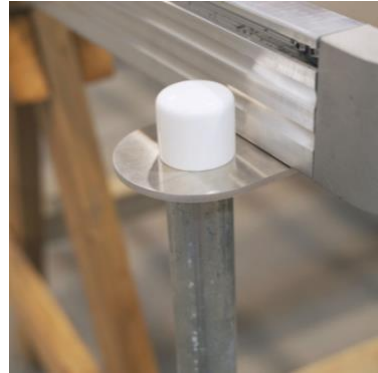

SPECIFICATIONS

Material/Composition: 6005 T-61 Marine-grade aluminum and stainless-steel hardware

Needed tools: 9/16" ratchet socket and wrench, 3/8" drill bit for bolt-on model, and a 5/16" Halen key for the modular model.

*Hardware is included for both the WELDED and MODULAR models

SKU NUMBERS

BOLTED SHORE-END PILE BRACKETS (PAIR) for WELDED FRAME: C05-000001

MODULAR SHORE-END PILE BRACKETS (PAIR): C05-000002

DESCRIPTION

Utilizing a simple pivoting system and small landscaping piles, we can secure our gangways on a sandy/grassy shoreline to ensure a safe passage from the dock. These are not 100% fail-proof (which is intended); the connection point releases in the event of a storm or rough water conditions and prevents potential damage to the gangway and its components.

They are preferred for light-duty residential applications. **Assembly required for the BOLTED version and MODULAR version.**

ASSEMBLY PROCEDURE - THE MODULAR GANGWAY SHORE-END PILE BRACKET

See instruction video:

https://www.youtube.com/watch?v=MPIWii0-r7Y&list=PLmLmDtH9FZgCJBbUSVaBxIWi_7XCzh6H2&index=9&t=45s

CANDOCK HINGES

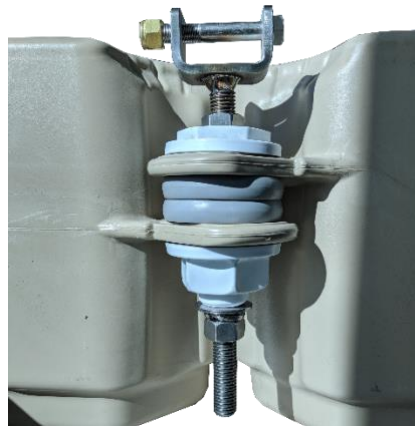
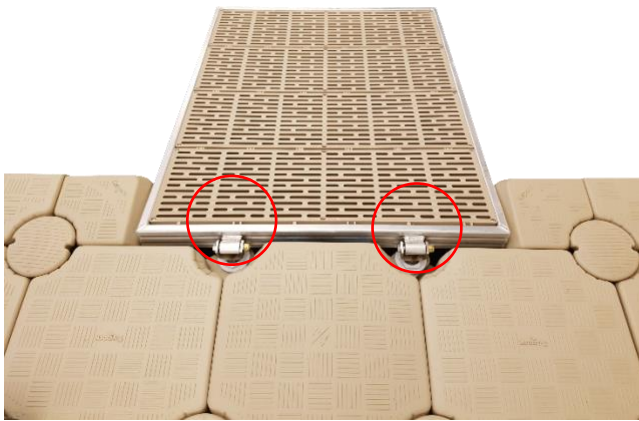

SPECIFICATIONS

Material/Composition: 6005 T-61 Marine grade aluminum, UHMW bushings, stainless-steel and brass hardware (1" 3/16 Nut)

Needed tools: 3/4" ratchet socket and wrench (for the pivot point), and a 5/16" Halen key.

*Hardware is included

SKU NUMBERS

MODULAR HINGES (PAIR): C05-000032

DESCRIPTION

Utilizing a simple pivoting system and height-adjustable threaded rods, we can allow a gangway to be firmly secured on the edge of a Candock dock while allowing for smooth upwards and downwards movements of the dock and gangway assembly to follow the fluctuations of the water levels. Usually, we include our SHORE-END PILE BRACKETS at the gangway's shore-end, allowing a second pivoting point on the entire assembly. Such configurations are often ideal on smooth sandy/grassy shorelines.

They are preferred for light-duty residential applications. **Assembly required.**

ASSEMBLY PROCEDURE - THE MODULAR GANGWAY CANDOCK HINGES

See instruction video:

https://www.youtube.com/watch?v=MPIWii0-r7Y&list=PLmLmDth9FZgCJBbUSVaBxIWi_7XCzh6H2&index=9&t=45s

SLIDERS (FOR WELDED AND MODULAR FRAMES)



SPECIFICATIONS

Material/Composition: HDPE

Needed tools: #3 Robertson head screwdriver (square) and drill bits if the slider is not pre-installed on the gangway frame.

*Modular slider always come with the MODULAR FRAME in the box.

SKU NUMBERS

HD PLASTIC SLIDER 3ft: C05-000016

HD PLASTIC SLIDER 4ft: C05-000017

DESCRIPTION

Simple yet efficient, this accessory prevents the cubes' premature wear underneath the gangway. It is lying on the Candock and is made of soft plastic that will not damage the cubes and remain extremely cheap to replace in the future.

They are preferred for light-duty residential applications. **Assembly required for MODULAR version.**

ASSEMBLY PROCEDURE - THE MODULAR GANGWAY SLIDER

See instruction video:

https://www.youtube.com/watch?v=MPIWii0-r7Y&list=PLmLmDtH9FZgCJBbUSVaBxIWi_7XCzh6H2&index=9&t=45s

NOTE

The inclusion of a **SLIDER is mandatory for all gangways** if there are meant to be lying on the Candock at the gangway's dock end portion. A gangway frame should never be installed without a SLIDER. Lastly, depending on the application, geometries, and gangway specification, the SLIDER may also be substituted by a ROLLER.

ROLLERS



***The photo shows an earlier version that was welded. This model has been replaced by a bolt-on version.

SPECIFICATIONS

Material/Composition: PVC pipe, aluminum tube, and stainless-steel hardware.

Needed tools: 3/4" ratchet socket and wrench (for the roller's pivot point), 9/16" ratchet socket and wrench, and 3/8" drill bit bolt-on model.

*Hardware is included

SKU NUMBERS

ROLLER FOR HD GANGWAY 90cm (3') – BOLT-ON: C05-000036

ROLLER FOR HD GANGWAY 120cm (4') – BOLT-ON: C05-000037

DESCRIPTION

Simple yet efficient, this accessory prevents the cubes' premature wear underneath the gangway. It is lying on the Candock and is made of PVC that will not damage the cubes and remain extremely cheap to replace in the future.

They are preferred for medium-duty residential light-duty commercial applications.



GANGWAY RECEPTION PLATES

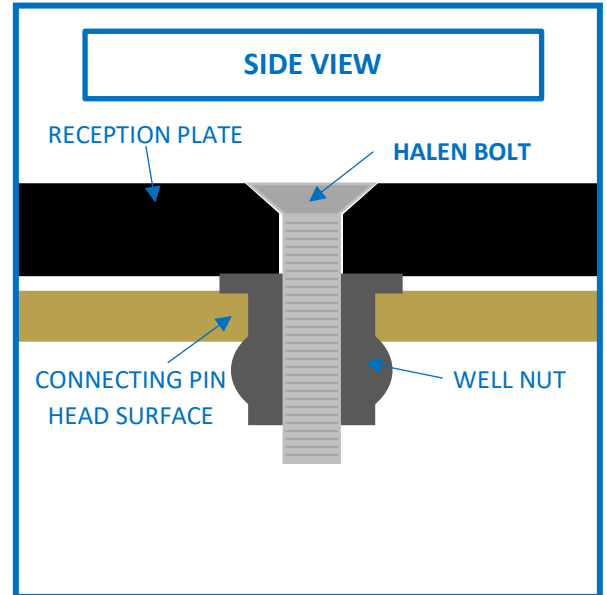
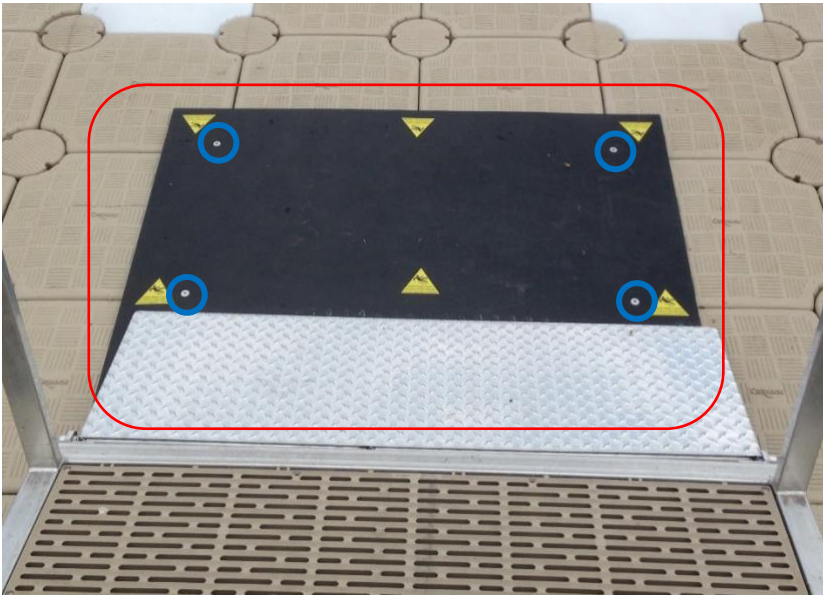

SPECIFICATIONS

Material/Composition: HDPE plate, rubber “well-nuts,” and stainless-steel hardware.

Needed tools*: A Power drill, 3/8” drill bit to drill the (4x) holes on the center of heads of the connecting pins, and a 7/32” Halen key to secure the plate into the rubber “well-nuts”.

*Hardware included

SKU NUMBERS

13mm (1/2”) GANGWAY RECEPTION PLATE 120cm x 150cm (4’ x 5’): C05-000033

DESCRIPTION

The GANGWAY RECEPTION PLATE allows the gangway to rub/slide/roll on a much flatter surface than our cubes' surface. It also prevents premature wear for the dock and gangway components. It is important that the plates' positioning allows for full coverage of the area where the gangway is subjected to travel onto the dock. It is possible to install 2 reception plates side by side to cover a greater area.

For installation, the plate itself acts as a template for drilling the holes in the connecting pins. It is imperative not to secure the plate directly on the cubes, which would compromise their buoyancy. Always position the holes (and well-nuts) onto the [surroundings connecting pins](#).

The GANGWAY RECEPTION PLATE should be highly considered for all WELDED FRAME gangways (12’ and +). Especially if the site is exposed to regular wave action or if the gangway is subjected to heavy pedestrian traffic.

TRANSIT PLATES (WELDED AND MODULAR FRAMES)



SPECIFICATIONS

Material/Composition: Aluminum checkered plate and HDPE slider, stainless-steel hardware.

Needed tools: 5/32 Halen key (for the set crews), 5/16" Halen key for the modular model.

*Hardware is included modular models

SKU NUMBERS

MODULAR GANGWAY TRANSIT PLATE 90cm x 40cm (3' x 16"): C05-000034

MODULAR GANGWAY TRANSIT PLATE 120cm x 40cm (4' x 24"): C05-000035

DESCRIPTION

The TRANSIT PLATES are allowing a smoother transition from the gangway to the dock. They are often required for ADA-compliant installations; they are also equipped with a SLIDER to ensure the TRANSIT PLATE's safe movements onto the dock. All our WELDED FRAME come equipped with a WELDED TRANSIT PLATE.

ASSEMBLY PROCEDURE - THE MODULAR GANGWAY TRANSIT PLATE

See instruction video:

https://www.youtube.com/watch?v=MPIWii0-r7Y&list=PLmLmDtH9FZgCJBbUSVaBxIWi_7XCzh6H2&index=9&t=45s

DECKINGS



SPECIFICATIONS

Material/Composition: Fiberglass Reinforced Plastic

Needed tools: Power drill to drill the gangway frame's holes and impact power drill to secure the gangway frame panels.

*#3 Robertson drill bit, 3/16 drill bit, and screws included with each panel

SKU NUMBERS

BEIGE DECKING 90cm x 30.48cm (3' x 12"): C05-000022

BEIGE DECKING 120cm x 30.48cm (4' x 12"): C05-000024

GRAY DECKING 90cm x 30.48cm (3' x 12"): C05-000023

GRAY DECKING 120cm x 30.48cm (4' x 12"): C05-000025

DESCRIPTION

Candock's DECKINGS consist of premium quality, non-slip, openwork design plastic panels. Made with top-of-the-line FRP plastic, they are incredibly durable and perfectly adapted for residential and commercial use.

Panels are not pre-assembled by Candock; lay the panels onto the gangway, pre-drill holes at every possible location using each panel as templates. Secure the panels using the provided stainless-steel screws, ideally using an impact drill.

KEY FOR CONNECTING PINS

MANUAL



DRILL



SPECIFICATIONS

Material/Composition: Painted steel

Needed tools for the DRILL model: High torque / Low-speed power drill or brushless & variable speed cordless drill

SKU NUMBERS

MANUAL KEY FOR CONNECTING PIN: C04-000006

DRILL KEY FOR CONNECTING PIN: C04-000007

CAUTION

Always proceed with caution if using a power drill to fasten the CONNECTING PINS; the drill can tend to “kick”. Use Protective footwear. Ideally, use a “double-handle” power drill to prevent wrist/arm injuries. If using a power drill to unscrew pins, always loosen-up the pins manually before using the drill.

KEY FOR NUTS

MANUAL



RATCHET SOCKET



SPECIFICATIONS

Material/Composition: Casted aluminum

Needed tools for the RATCHET SOCKET model: ½” Drive ratchet

SKU NUMBERS

MANUAL KEY FOR NUT: C04-000003

RATCHET SOCKET KEY FOR NUT: C04-000002

PILING DRIVER, PILING BULL AND PILING LEVER

2 7/8" PILING BULL



2 7/8" AND 1 11/16" PILING DRIVER



2 7/8" PILING LEVER

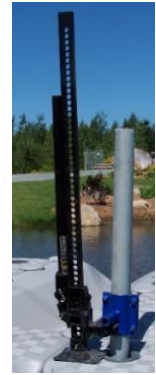

SPECIFICATIONS

Material/Composition: Painted steel

Needed tools for the PILING DRIVERS: 8, 10, or 12lbs sledgehammer

Needed tools for the PILING LEVER: Farm Jack and ¾ ratchet socket or wrench

SKU NUMBERS

2 7/8" PILING BULL: C04-000001

2 7/8" PILING DRIVER: C04-000010

2 7/8" PILING LEVER: C04-000009

INSTRUCTIONS

While referring to the "Anchoring products Owner's manual" under the chapter "Pilings and G2 post cube method", please observe the following guidelines. Always proceed with caution and safety and use proper footwear, gloves, and workwear.

PILING BULL

- 1-Insert pile into the POST CUBE and let it rest on the bottom of the seabed.
- 2-Insert the ram/bull onto the pile and thrust the pile down into the ground by knocking the ram vigorously on the pile's head.
- 3-Repeat until desired depth of the pile is reached.

PILING DRIVERS

- 1-Position the pile where needed.
- 2-Insert the driver onto the pile, firmly secure it onto the pile with the set screw. Thrust the pile down into the ground by knocking the driver vigorously on the head with a sledgehammer.
- 3-Repeat until desired depth of the pile is reached.

PILING LEVER

- 1-Insert PILE LEVER on the 2 7/8" pile that needs to be removed and fasten the lever manually at approx. 5" from the dock surface.
- 2-Using a 3/4" socket or wrench, securely tight the lever in place at the desired height so the farm jack can be inserted underneath the lever.
- 3-Place the farm jack underneath the lever while making sure that the foot of the farm jack finds support on the POST CUBE's flange.
- 4-Extract the piling by normally operating the farm jack.
- 5-Once the pile is loosened up; you can still use the pile lever as a handle to pull the pile out.

TOOLS FOR CANDOCK MODULAR RAILINGS

DRILLING AND CUTTING JIG



MANUAL KEY FOR SURFACE POST



RATCHET SOCKET FOR SURFACE POST



SPECIFICATIONS

Material/Composition: Aluminum, HDPE, or stainless steel

Needed tools for the DRILLING AND CUTTING JIG: Power drill (plugged or cordless) and miter saw

Needed tools for the RATCHET SOCKET FOR SURFACE POST: High torque / Low-speed power drill or brushless & variable speed cordless drill or ½" drive ratchet

SKU NUMBERS

DRILLING AND CUTTING JIG: C04-000008

MANUAL KEY FOR SURFACE POST: C04-000004

RATCHET SOCKET FOR SURFACE POST: C04-000005

ASSEMBLY AND OPERATIONS PROCEDURES

See instruction video:

https://www.youtube.com/watch?v=jWNzyqzyqzI&list=PLmLmDtH9FZgCJBbUSVaBxIWi_7XCzh6H2&index=12&t=201s