



FORD EXPLORER ST BIG BRAKE KIT

SA6, SA4 & SA4A BRAKE PAD SPECIFICATIONS

Illustrations are not to scale

SA6 - 6 PISTON FRONT CERAMIC GRAPHITE OR SEMI-METALLIC BRAKE PAD

189.7 x 87.5 x 17.6 FG

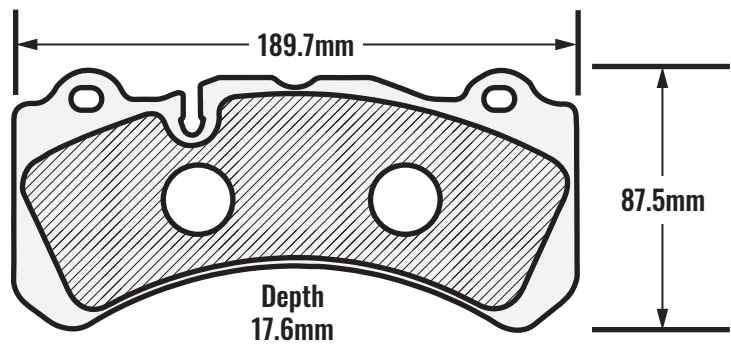

SA4 - 4 PISTON REAR CERAMIC GRAPHITE OR SEMI-METALLIC BRAKE PAD

131.8 x 66.8 x 18.0 FG

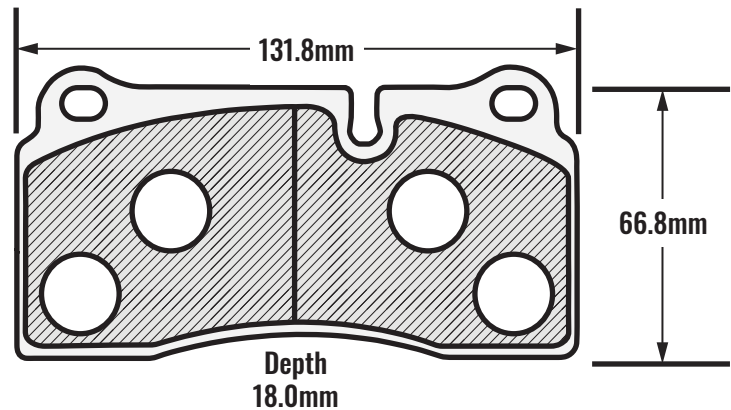

SA4A - 4 PISTON REAR WITH INTGRATED EPB CERAMIC GRAPHITE OR SEMI-METALLIC BRAKE PAD

131.5 x 62 x 16.0 FG

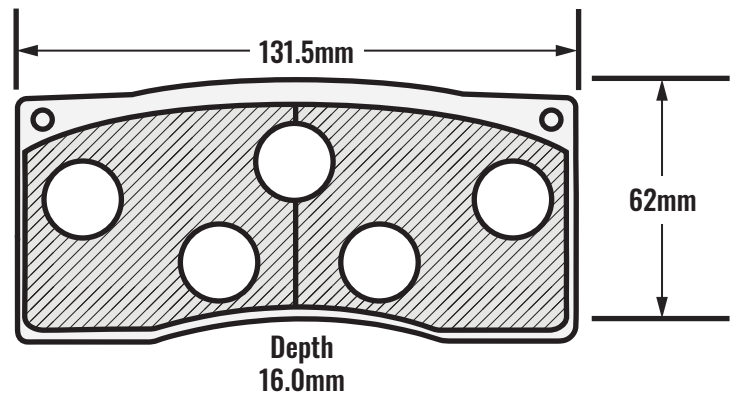

PAD SPECIFICATIONS

Brake Pad Material:	Ceramic Graphite Composite	Semi-Metallic Composite
Heat Resistance:	0-550C	0-700C
Friction Rating Codes:	0.38Mu(F)-0.43Mu(G)	0.42Mu(F)-0.48Mu(G)

Rev December 2023