

RAPIDO
design GI-RA

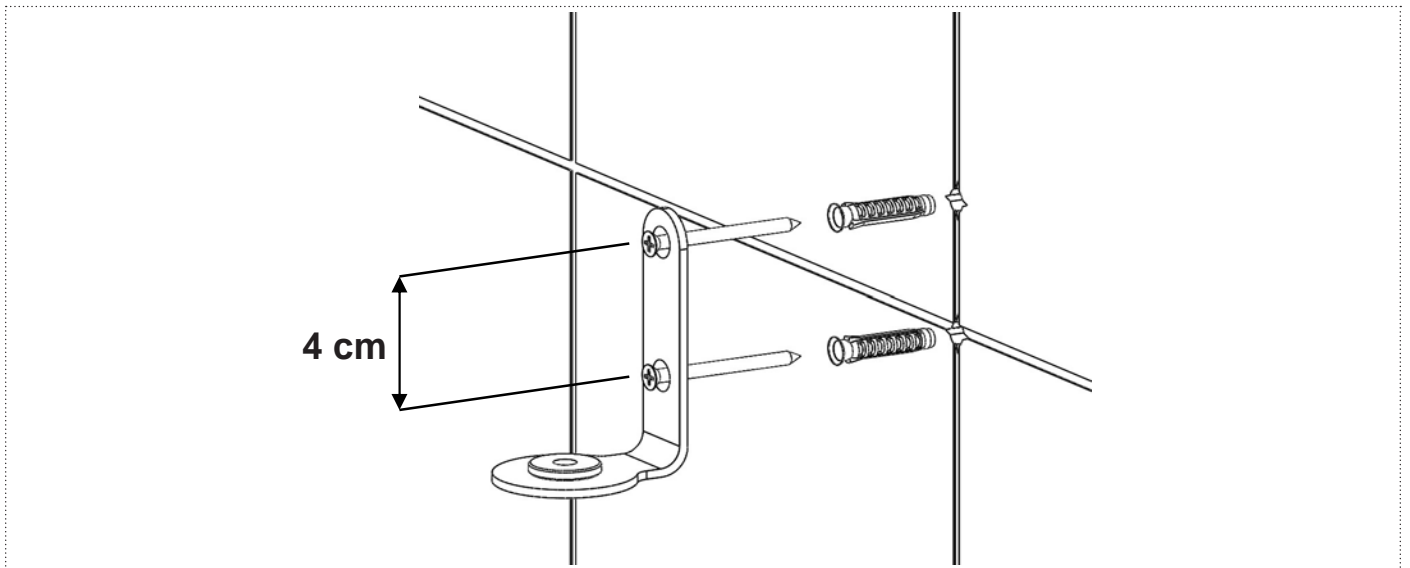

antoniolupi

MADE IN ITALY



Rapido2: Wall connection.

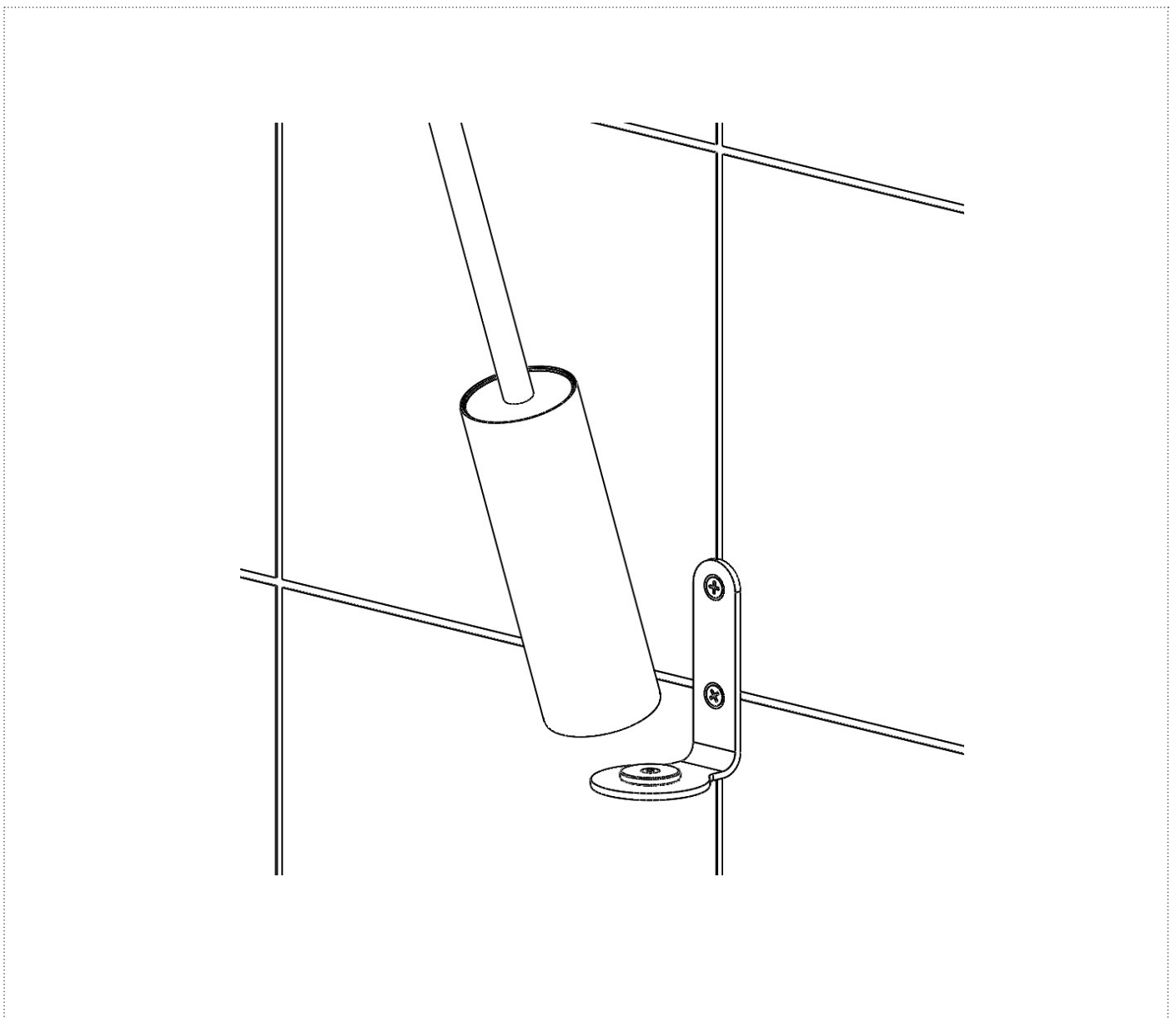

Rapido2: Magnetic connection between toilet brush and wall support.

MAINTENANCE OF STAINLESS STEEL SURFACES

Stainless steel is an alloy composed by iron and carbon which combines the typical mechanical properties of carbon steels and peculiar characteristics of resistance to corrosion. It is defined stainless steel because it resists to corrosion thanks to a thin oxide film that forms on its surface. The film becomes a natural barrier against the effects of atmospheric agents. It is therefore wrong to think that stainless steel is indestructible and does not corrode, stainless steel can also suffer considerable damage if not treated with care. Its strength and durability, are closely related to proper use, good maintenance and use of appropriate cleaning products and materials in order to preserve the original characteristics. Oxidation spots, limestone deposits and rust can appear on the surfaces if they are not cleaned and maintained properly.

MAIN CAUSES OF OXIDATION

Ferrous residuals left to settle on damp surfaces (not dry) carried by water or products used for cleaning (scrapers, steel wool, etc.). Limestone it contributes to weaken the steel in some spots or in areas where it has accumulated. Encrustations they can accumulate in the less accessible parts. Cleaners containing chlorine or ammonia not properly rinsed.

Salt if not dissolved in hot water or as dry residue of evaporated liquids etc..

PRECAUTION

It is important to know that the use of steel wool or similar tools used for removing solid residues, may leave microscopic particles that detach from these tools and remain deposited on the surface. For contact, these particles, trigger a rapid irreversible corrosion process or hardly restorable if action is not taken in a short time (an iron particle left in a humid environment takes a few hours to cause a major trigger of corrosion);

In order to avoid limestone deposits and encrustations, it is recommended to wash the product with a solution of warm water and vinegar, or with liquid soap diluted in water. Then dry with a soft cloth.

The use of detergent products containing chlorine, such as bleach or similar products normally available on the market must be avoided because they can produce serious effects of corrosion if not abundantly, quickly and appropriately rinsed;

The contact or vapors from acid (muriatic acid / hydrochloric acid) or alkaline (sodium hypochlorite / bleach) or ammonia, used directly or diluted/ contained in ordinary detergents for cleaning and sanitation of floors, tiles and washable surfaces, may cause a corrosive / oxidizing process on stainless steel;

Do not place on the surface of stainless steel rags, cleaning clothes, sponges or anything similar, imbued with common detergents containing chlorine or ammonia before having them neutralized and rinsed properly from this "contact" with a neutral detergent;

Rinse thoroughly and dry the surface.

WARNING

Failure to observe these precautions will void the warranty.

TOXICITY

The product does not appear toxic to humans, animals or to the environment.

ECOLOGY

Only discard in appropriate disposals according to rules and regulations in your area.

antoniolupi

73
VIA MAZZINI
75

Antonio Lupi Design S.p.A.
via Mazzini 73/75 - 50050 Stabbia
Cerreto Guidi (Firenze) - Italy
T +39 0571 586881_95651
F +39 0571 586885
www.antoniolupi.it
lupi@antoniolupi.it