

TECHNICAL DATA

1. **Isola Convivium** l 362 x p 185 x h 92,6 cm
ante Convivium Elegant acciaio inox Vintage
cassetti anta con gola, vani a giorno in fossil oak NTF
top acciaio inox vintage h 3,1 cm con involucro 12 mm
e bordo 6 mm, lavello, piano cottura Specialty con
griglie in ghisa, griglie in PaperStone®
e tagliere in legno, scorrevoli
vetro paraspruzzi
2. **Tavolo snack integrato** l 240 x p 95 cm
fossil oak NTF a doghe
3. **Cappa New Convivium** l 240 x p 90 cm
acciaio inox Vintage con vetro perimetrale
4. **Parete contenitori** l 391,4 x p 60 x h 232 cm
ante Convivium Elegant Fenix NTM® nocciola
cassetti anta con gola fossil oak NTF e sponde nere,
attrezzati con nuovi accessori Box Globe
MAC contenitore per piccoli elettrodomestici
120 x h 60 cm, interno fossil oak NTF
luce interna integrata, prese elettriche, vassoio
estraibile, cornice in acciaio e vetro Stopsol
forni e frigoriferi integrati
luce interna LED 3000K a diffusione indiretta

1. **Convivium island** w 362 x d 185 x h 92.6 cm
Convivium Elegant doors in Vintage stainless steel
drawers with grooved handle, open spaces in NTF fossil oak
3.1 cm thick worktop in Vintage stainless steel with 12 mm
recess and 6 mm edge, sink, Specialty hob with cast
iron pan supports, sliding PaperStone® grids and
wooden chopping board
glass splash guard
2. **Built-in snack table** w 240 x d 95 cm
slatted NTF fossil oak
3. **New Convivium hood** w 240 x d 90 cm
Vintage stainless steel with glass border
4. **Wall of tall units** w 391.4 x d 60 x h 232 cm
Convivium Elegant doors in Fenix NTM® hazelnut
drawers with door with NTF fossil oak grooved handle
and black sides, fitted with new Box Globe accessories
MAC (Mini-Appliances-Container) 120 x h 60 cm,
NTF fossil oak interior
integrated internal lighting, electric sockets, pull-out tray,
frame in steel and Stopsol glass, built-in fridges and ovens
internal diffused indirect 3000K LED lighting

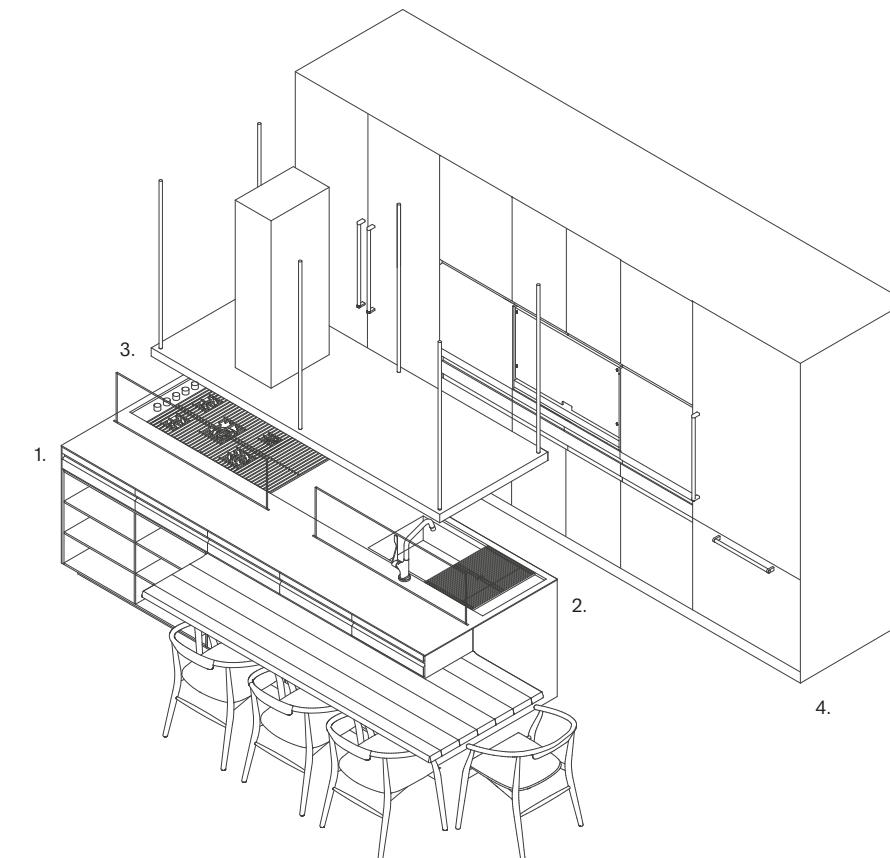

MAC (MINI-APPLIANCES-CONTAINER)

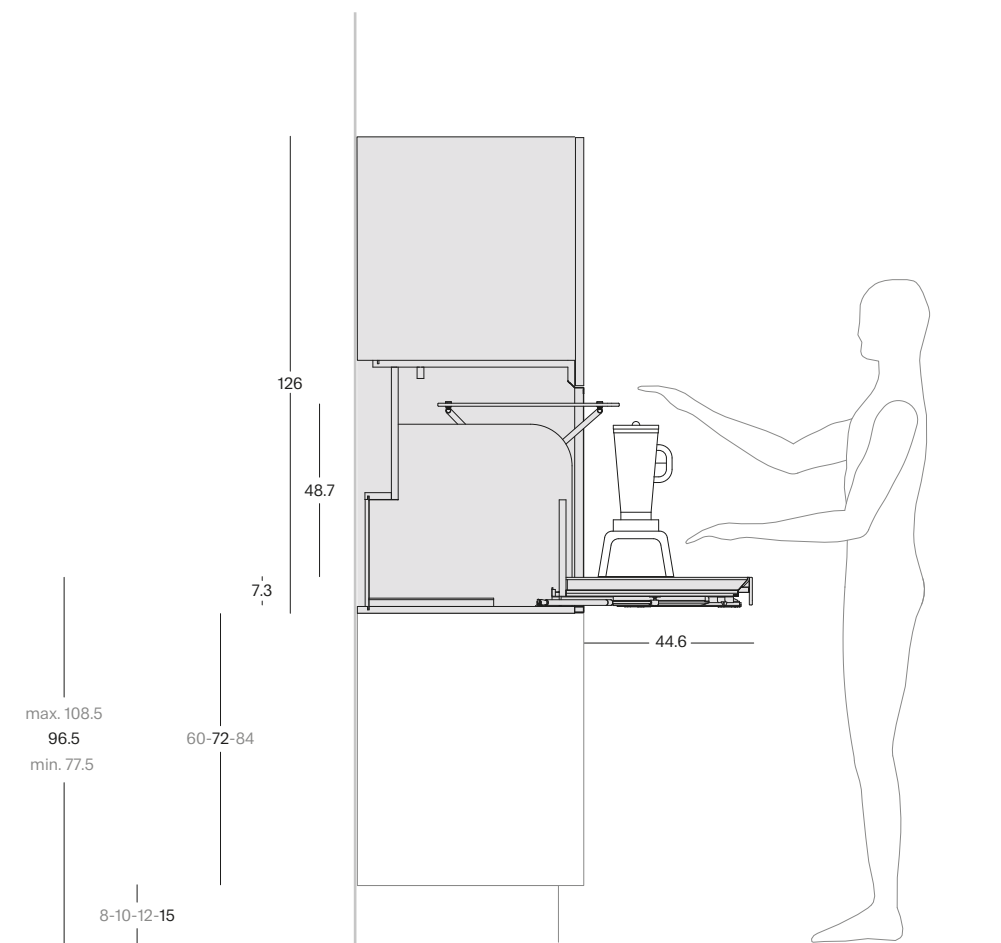

Il MAC (Mini-Appliances-Container), è un mobile dedicato al contenimento e all'uso dei piccoli elettrodomestici. Disponibile in due dimensioni, nei legni della Collezione, è completo di vassoio estraibile, 2 prese per l'alimentazione elettrica e luce interna

LED 3000K, impugnatura integrata per l'anta realizzata in vetro temperato Stopsol in finitura specchio. All'interno della parete di contenimento, il MAC trova perfetto allineamento con la modularità verticale della Collezione.



The MAC (Mini-Appliances-Container) is a unit specifically designed for storing and using small appliances. Available in two sizes and in the wood finishes of the Collection, it contains pull-out tray, 2 power sockets and internal

3000K LED lighting. The door, with built-in grip, is of mirror-finish Stopsol tempered glass. Inside the wall, the MAC is perfectly in alignment with the vertical modularity of the Collection.