

dadada[®]

Lala dresser big

Assembly instructions





Your baby's first...

We believe every family deserves beautiful spaces, quality construction that spans generations, and the peace of mind that comes with knowing their baby is at the center of everything we do.

dadada is modern nursery furniture designed with baby's first moments in mind. From form to function, base materials to baby-safe finishes, each piece is created to grow alongside little ones and provide parents with a trusted foundation for their family's most precious memories.

what makes us special?



thoughtfully controlled manufacturing

all our cribs are manufactured in Italy in well-established, certified factories that use state-of-the-art modern technologies.



one-year warranty on our dressers

we guarantee the quality of our produces and offer a limited warranty to protect you against product failure or damage.



baby-safe finishes

our paints and stains are ALWAYS lead and phthalate free, and meet strict juvenile and industry safety standards.



affordable luxury

we sell our modern, beautifully designed pieces at attainable prices because we believe that every baby deserves the absolute best in design.



sustainably sourced, durable materials

we use hardwoods that are not only aesthetically beautiful, but also strong enough to last generations, reducing the amount of disposable furniture that finds its way to our landfills.



GREENGUARD GOLD Certified Cribs

for indoor-air-emissions testing according to stringent requirements exceeding the State of California indoor air quality for schools and GSA standards.

learn more on our website





Thank you for purchasing our product. Please follow these assembly instructions carefully - they will save you time and make assembly easier and prevent possible damage to your new dadada furniture.

We strongly recommend assembling this unit on a soft surface, like carpet or a blanket.

When moving dadada furniture, always lift the product off the floor. Dragging or sliding the furniture can both damage the product and scratch your floors.



CAUTION

- READ ALL INSTRUCTIONS BEFORE USING THIS PRODUCT.
- KEEP THESE INSTRUCTIONS FOR FUTURE USE.
- NEVER PUT YOUR BABY ON TOP OF THE DRESSER WITHOUT A CHANGING TRAY



Before you start to assemble,
we highly recommend
watching the instructional
video on our website:
dadadababy.com

Your baby's first dresser

dadada:
Your baby's first...







Lala dresser big



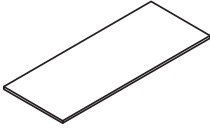
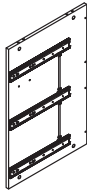
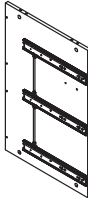
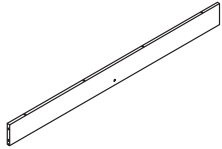
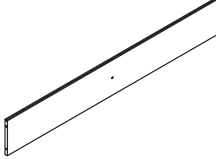

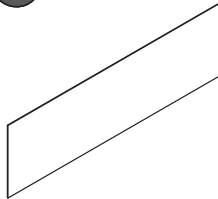
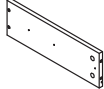
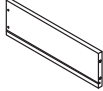
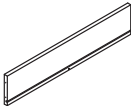

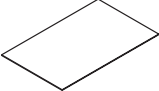
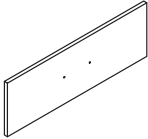
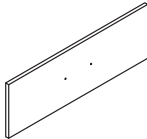
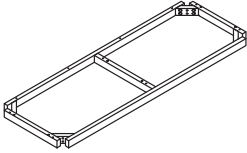





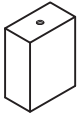

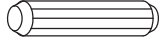
Parts List

.....

Please check to make sure you have all parts listed here before assembling. For any missing or faulty parts, please contact our Customer Care team. Customer Care contact info can be found on the last page of this manual.

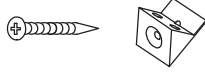
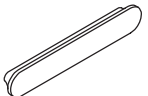
1 x1 	2 x1 	3 x1 	4 x1 
5 x1 	6 x1 	7 x1 	8 x6 
9 x6 	10 x6 	11 x6 	12 x6 
13 x3 	14 x3 	15 x1 	16 x4 

Parts list

<p>17 x1 H 2.36" / 60mm</p> 	<p>A x52</p> 	<p>B x52</p> 	<p>C x12</p> 
<p>D x2</p> <p>Ø7x48</p> 	<p>E x48</p> <p>Ø3.5x14</p> 	<p>F x8</p> <p>M6x60</p> 	<p>G x8</p> 
<p>H x1</p> <p>4mm</p> 	<p>I x24</p> <p>Ø4x40</p> 	<p>J x40</p> 	<p>K x6</p> 
<p>L x12</p> <p>Ø4x30</p> 	<p>M x1</p> <p>M6x40</p> 	<p>N x1</p> 	

Extra fittings

A +3

B +3

C +3

E +3

F +2

G +2

I +3

J +3

L +3

Tools Required for Assembly

(not included)

Images for illustration purposes only.

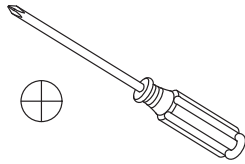
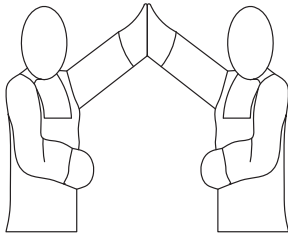

Overview

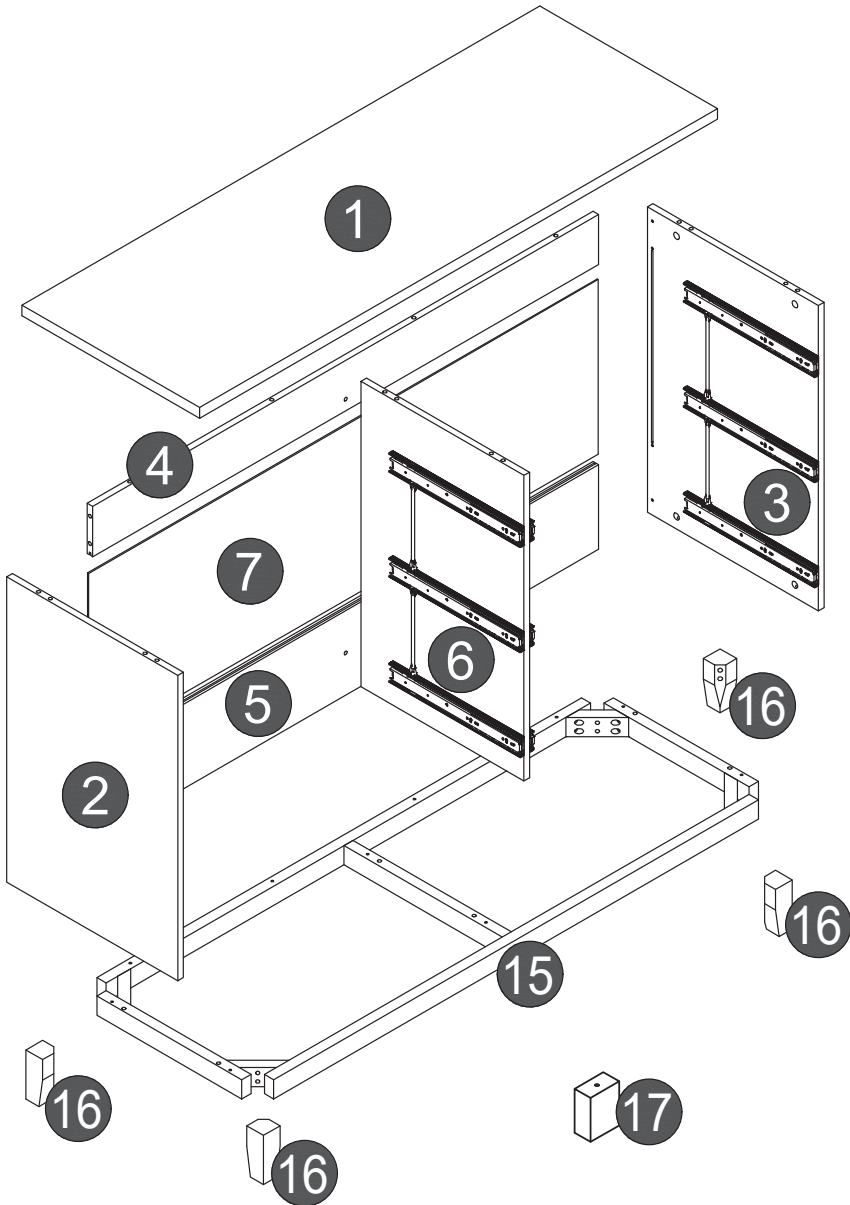

Overview

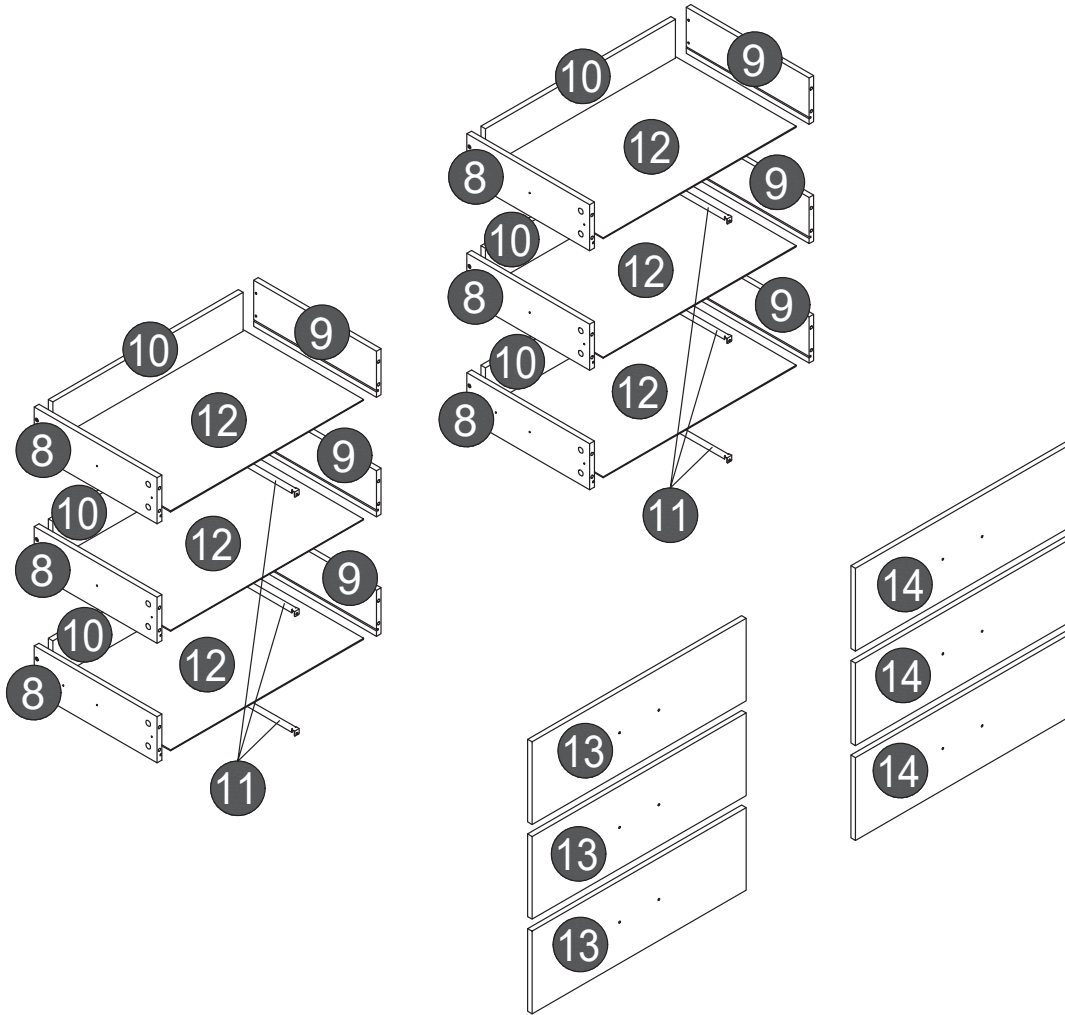

1

B x8 

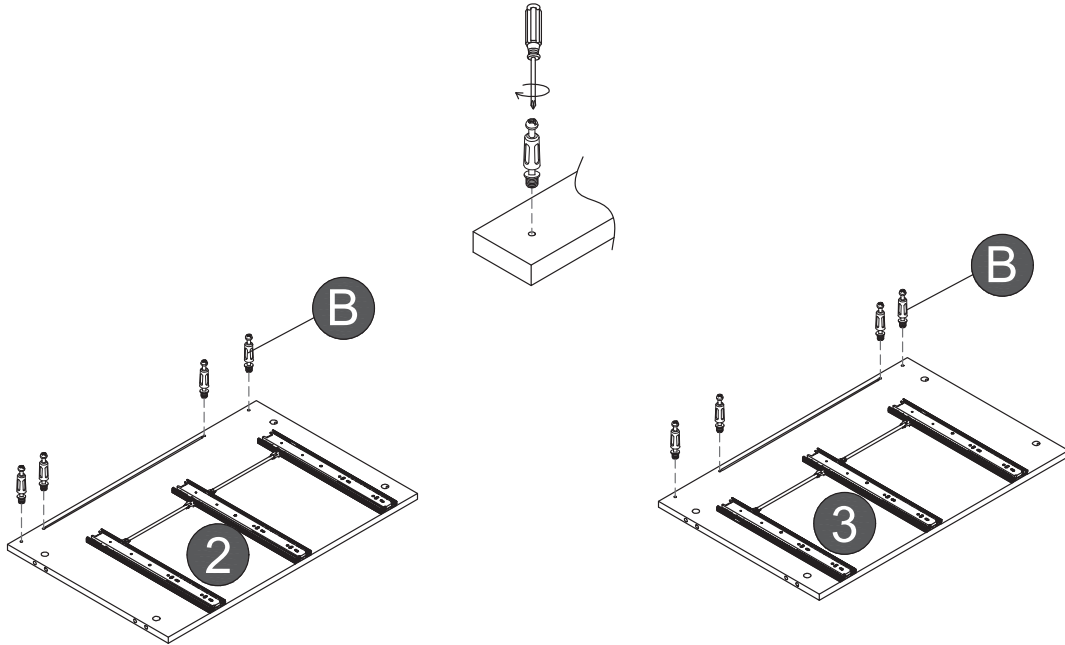

2

A x2 

Upside down

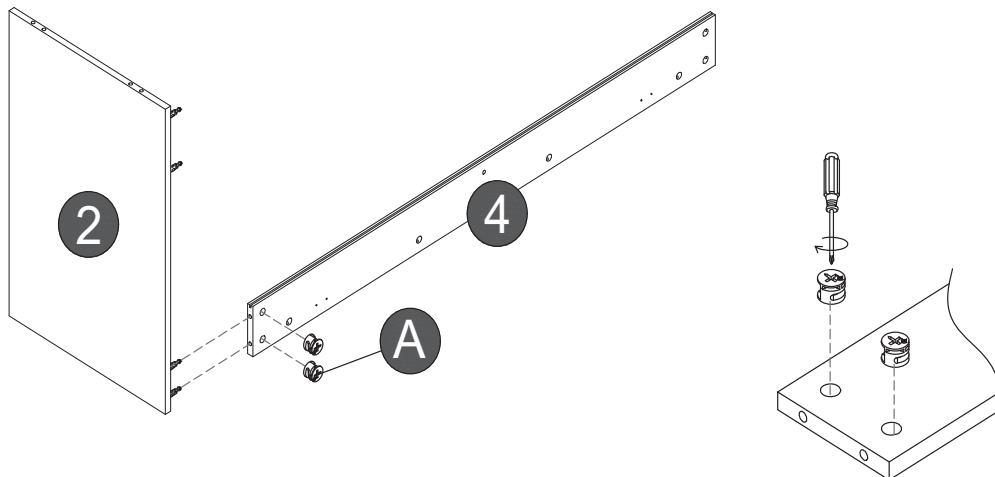

3

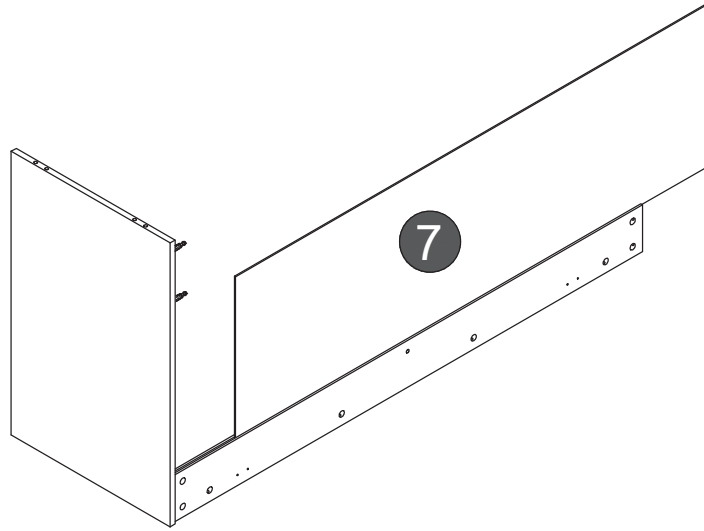

4

A x2

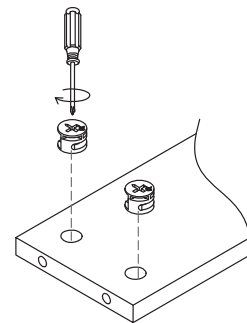
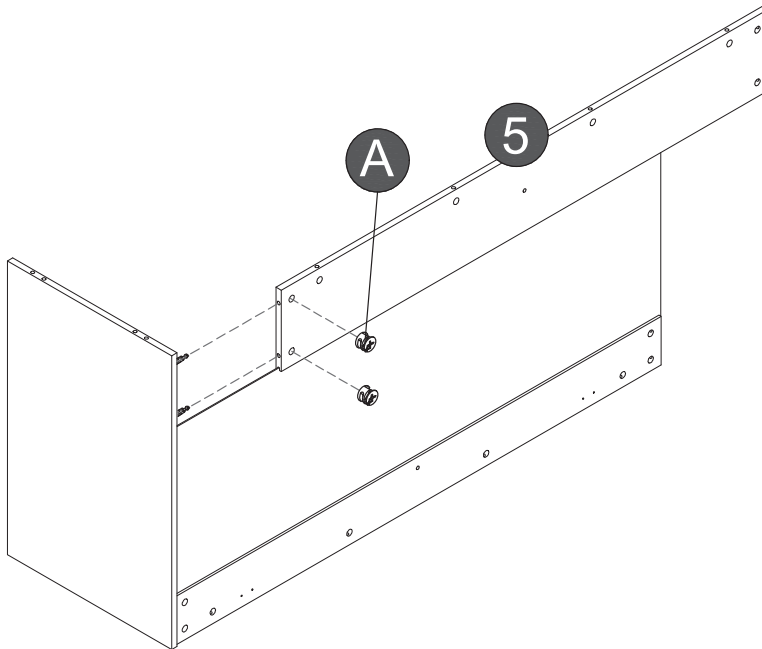

5

D x2 

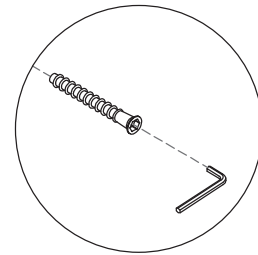
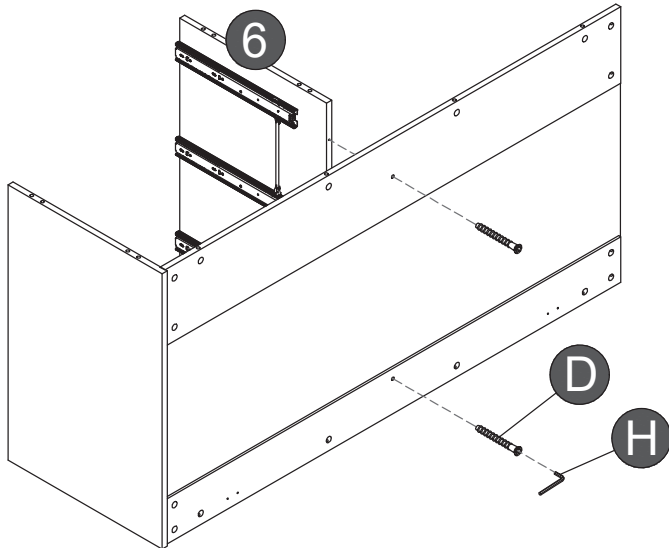

6

A x4 

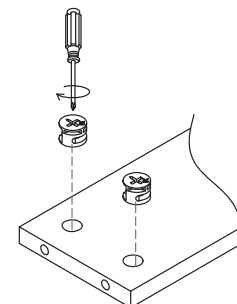
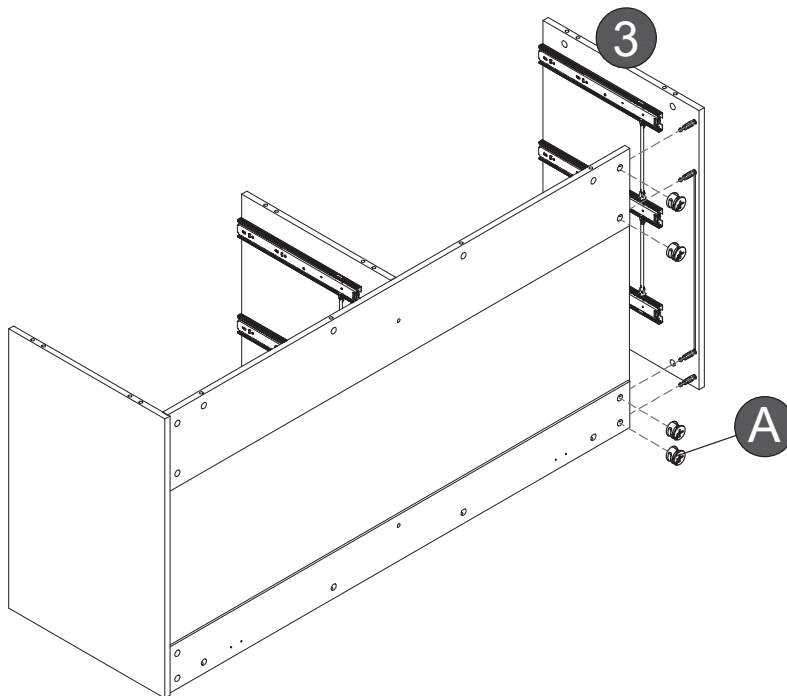

7

C x6

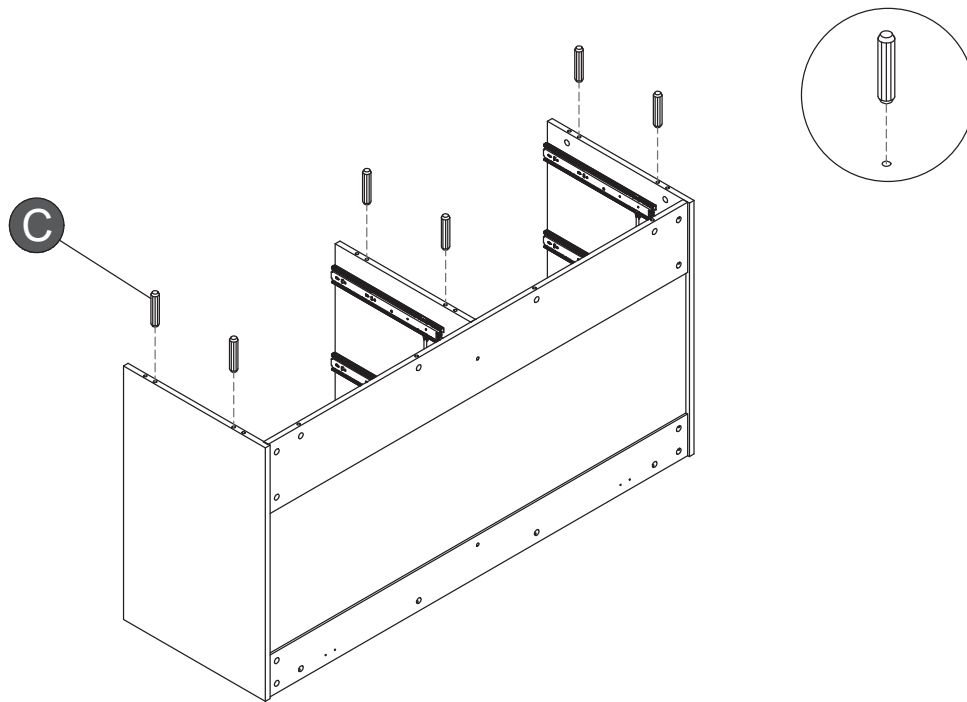

8

F x8

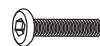

G x8

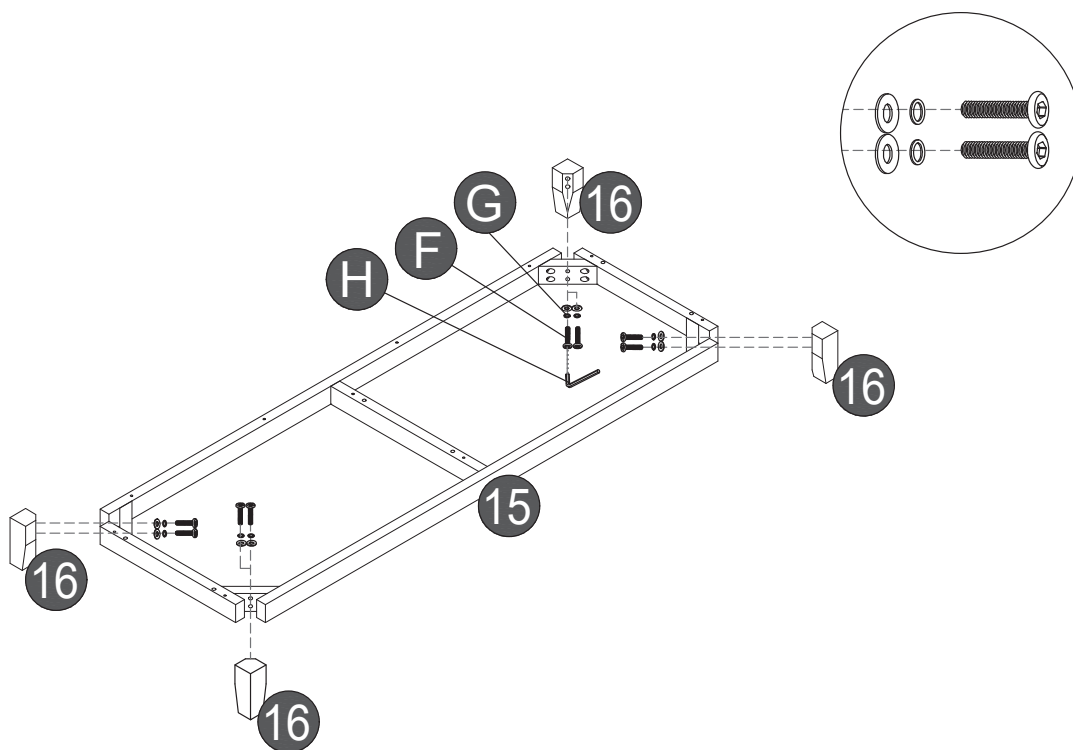

9

B x8



N x1

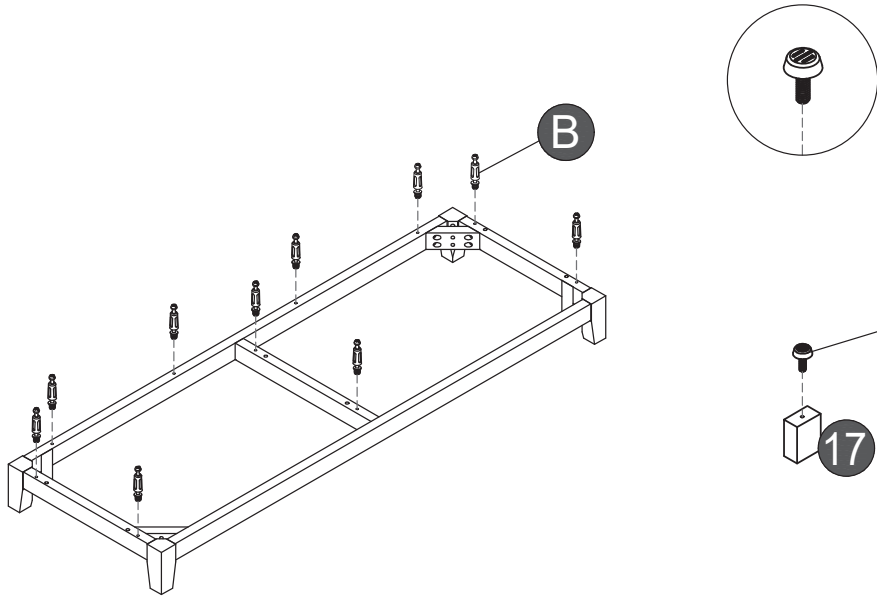

10

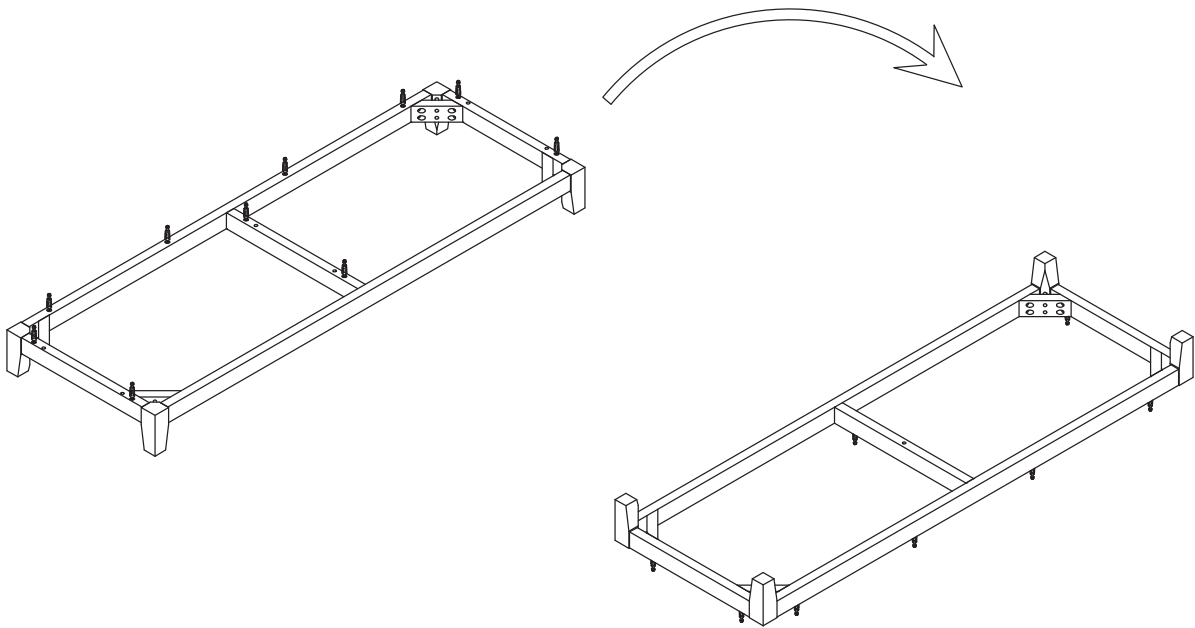

11

A x10



M x1

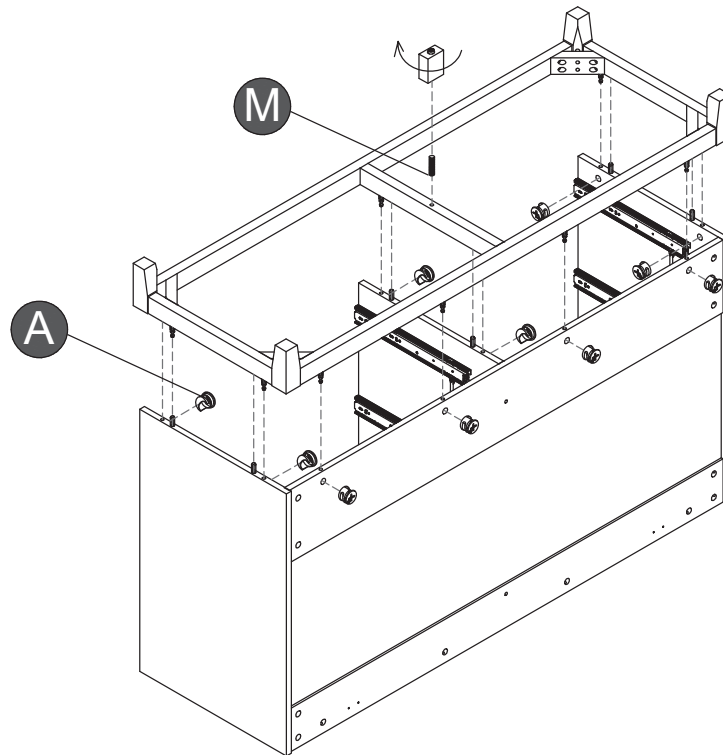

12

Turn over

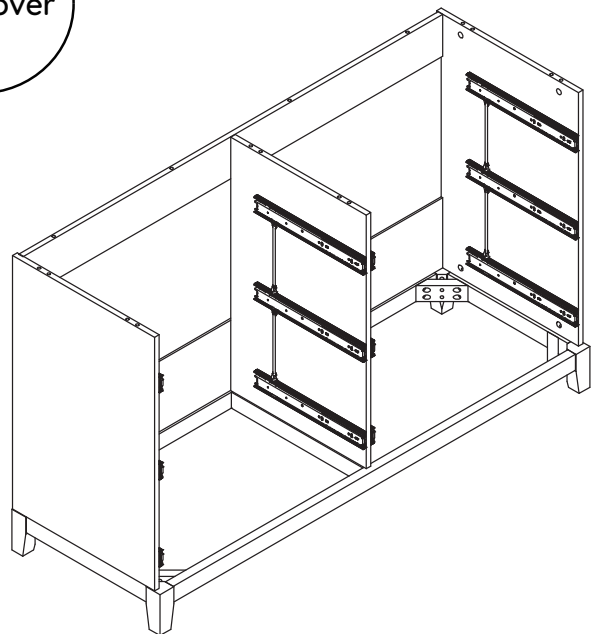
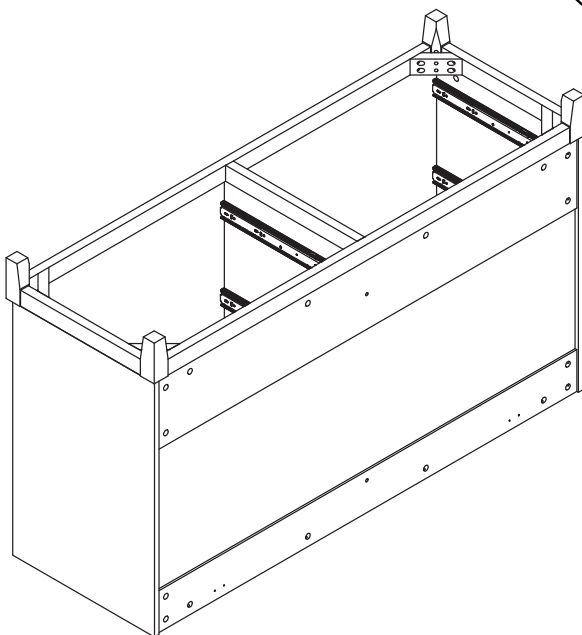

13

C x6 

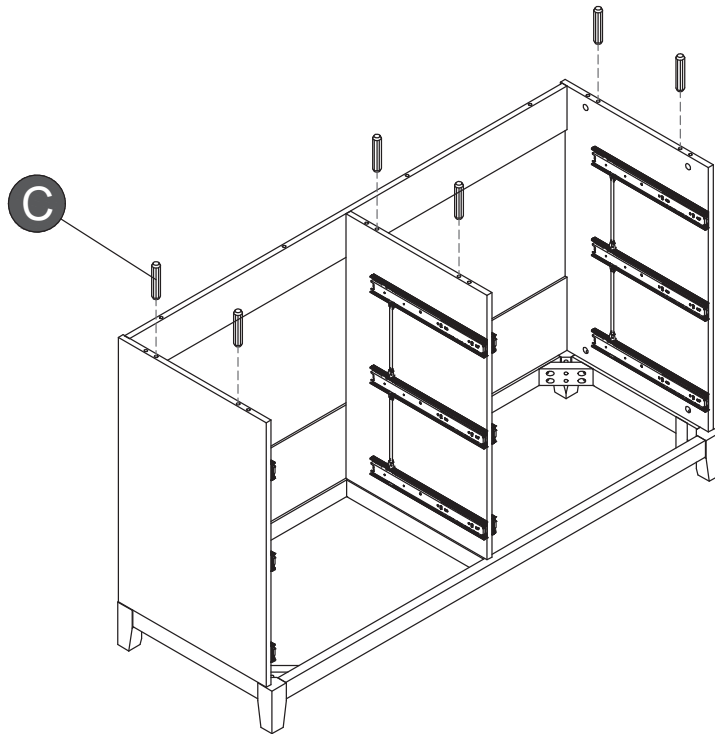

14

B x10 

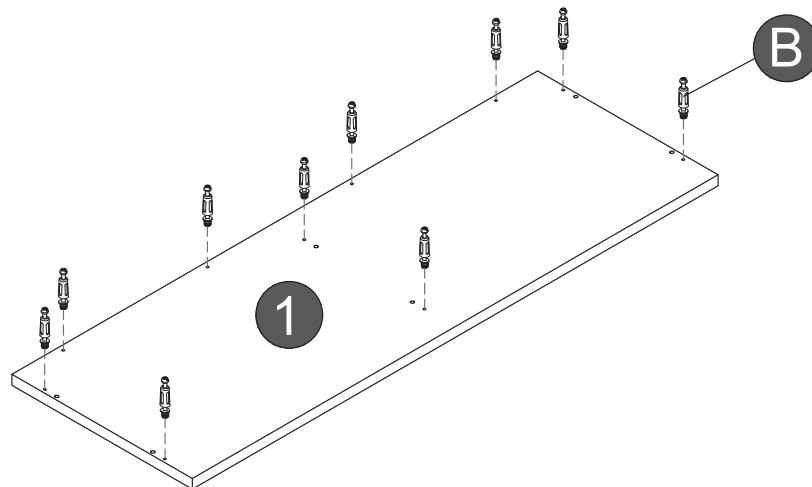

15

A x10

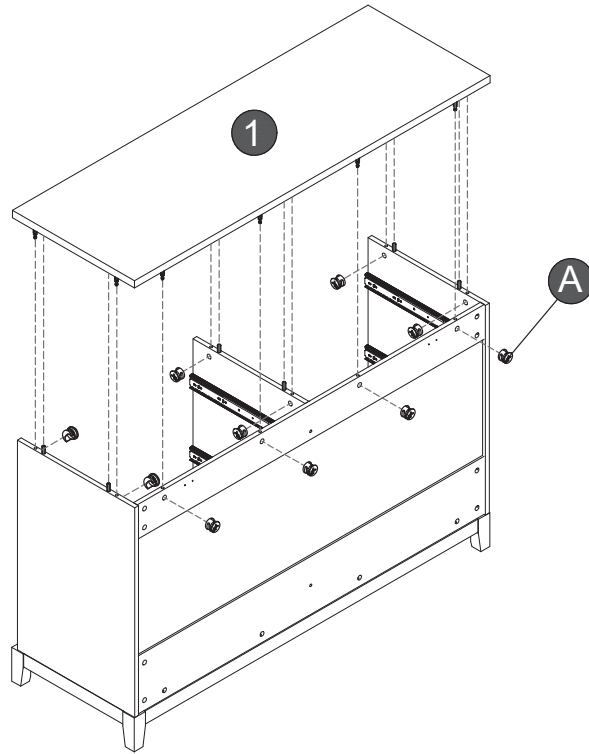

16

J x4

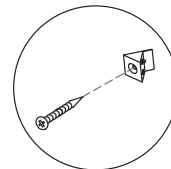
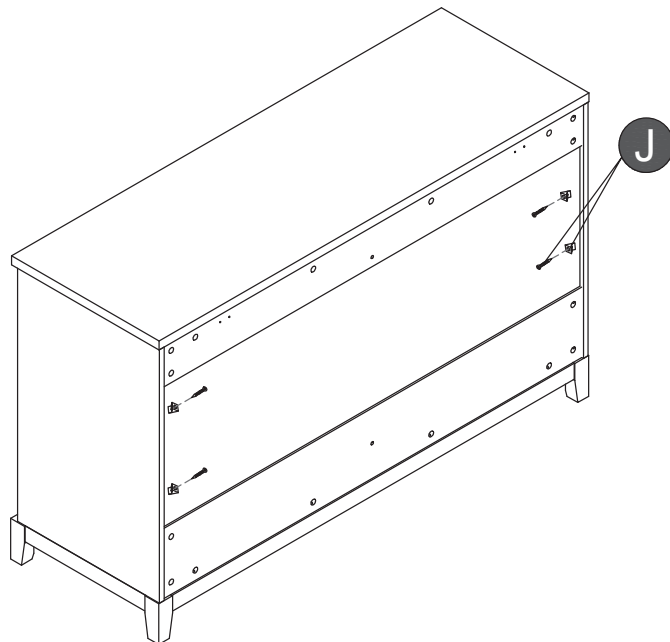

17

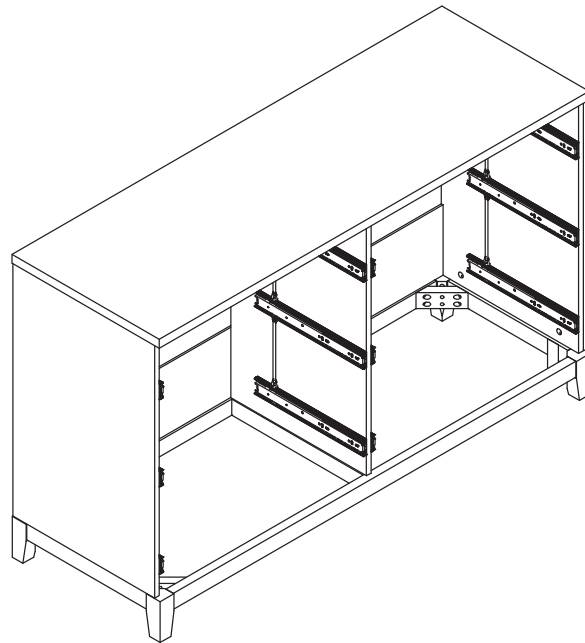

18

B x24 

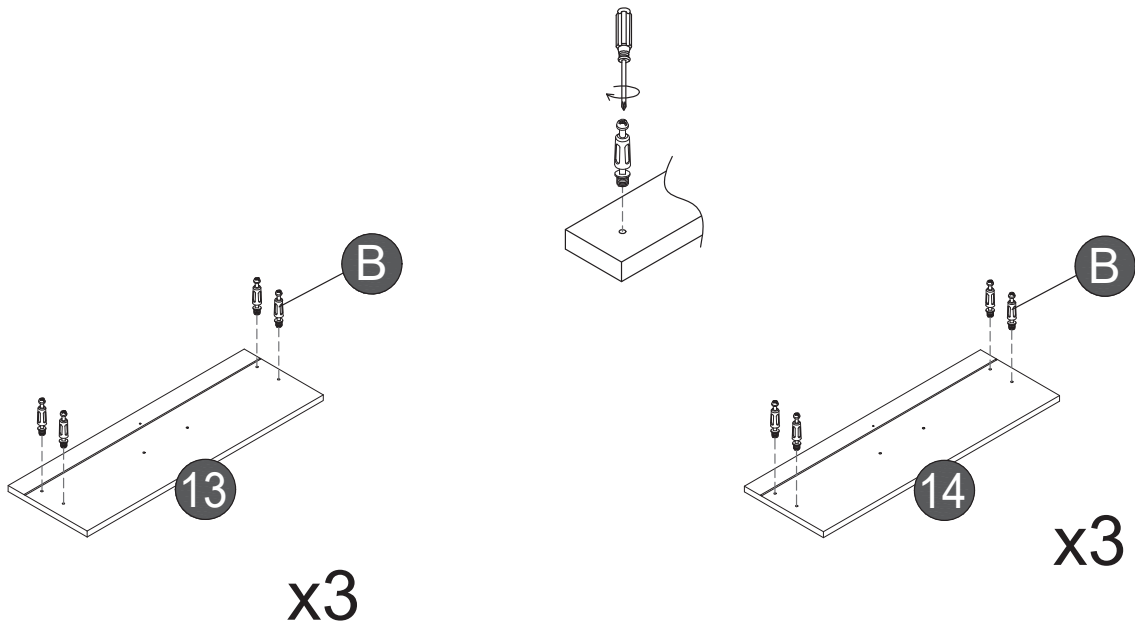

19

1 x24 

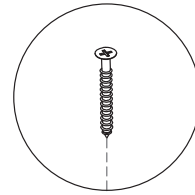
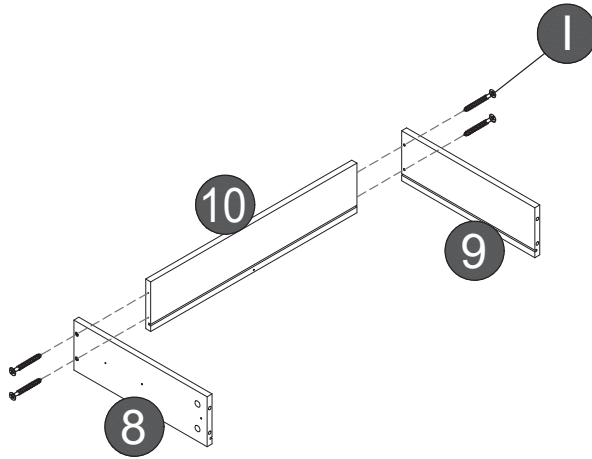

x6

20

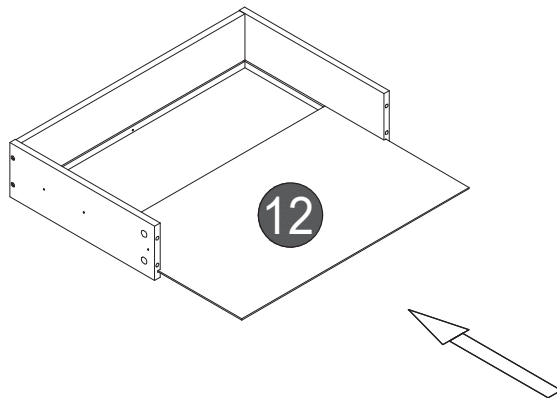

x6

21

A x4



K x1

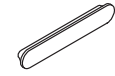

L x2



	WARNING Children have died from furniture tipover. To reduce the risk of furniture tipover: - ALWAYS use all the screws provided. - ALWAYS use the correct tools to tighten the screws. - ALWAYS place heavy items on the bottom of the shelves. - ALWAYS follow the maximum load capacity labels in the instruction manual. - Do not use the furniture on uneven surfaces. - Do not use the furniture on stairs.		AVERTISSEMENT Des enfants sont morts à cause d'un meuble qui s'est renversé. Pour réduire le risque de renversement: - TOUJOURS utiliser le dispositif de vissage entièrement fourni. - TOUJOURS utiliser les outils adéquats pour serrer les vis. - TOUJOURS placer les objets lourds sur les étagères inférieures. - TOUJOURS respecter la capacité maximale indiquée sur les étiquettes. - Ne pas utiliser le meuble sur des surfaces irrégulières. - Ne pas utiliser le meuble sur des escaliers.
---	---	---	---

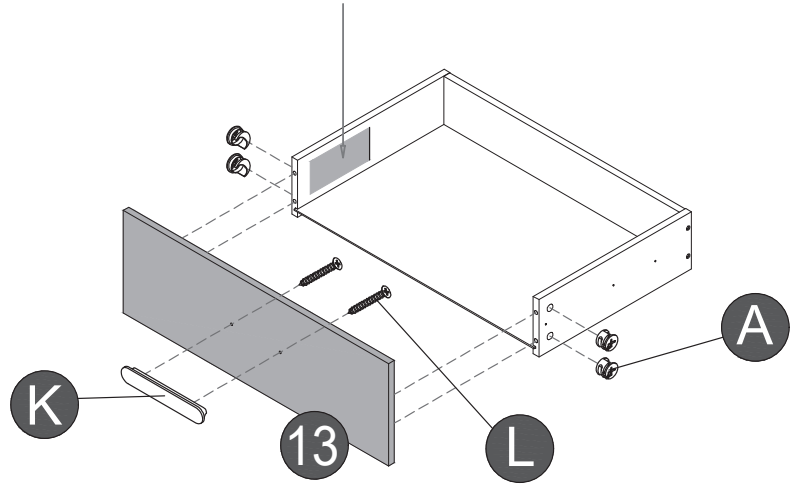

22

A x20



K x5

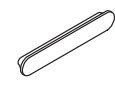

L x10

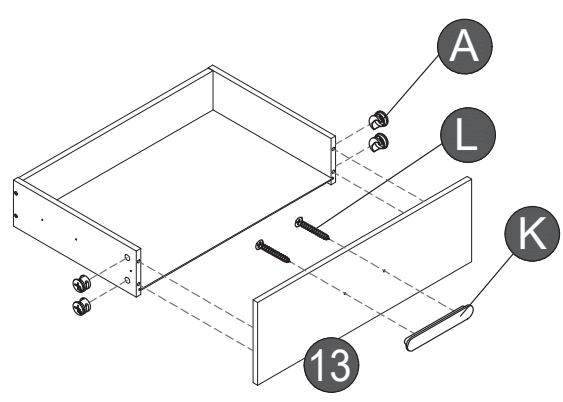
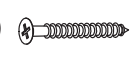

x2

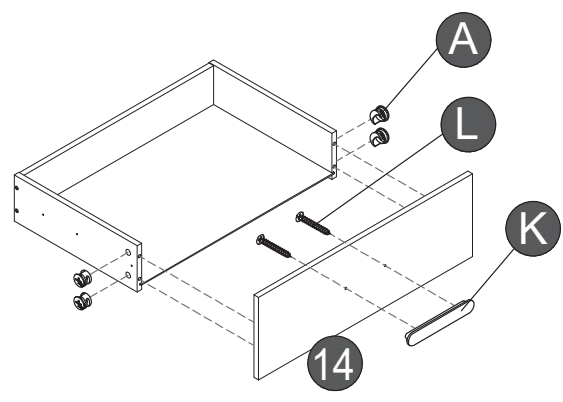

x3

23

E x12



J x36

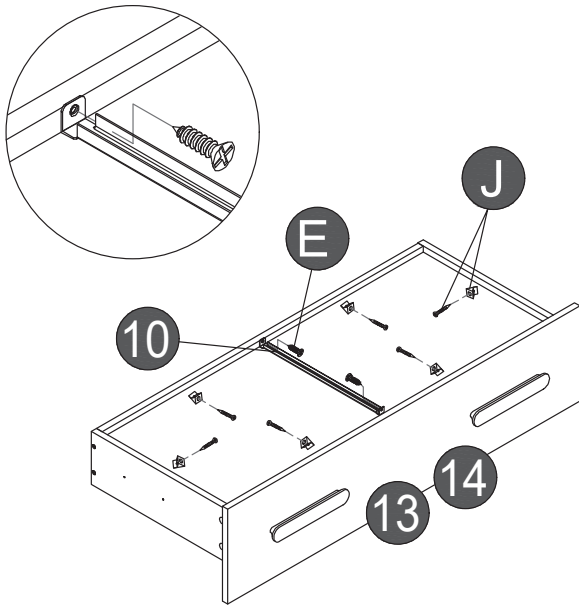

x3

24

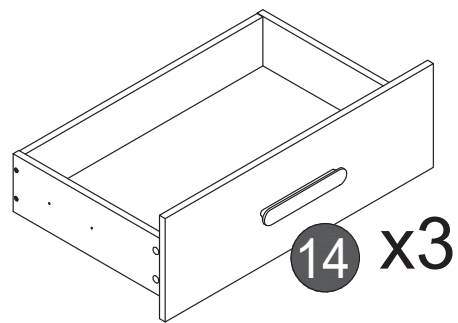
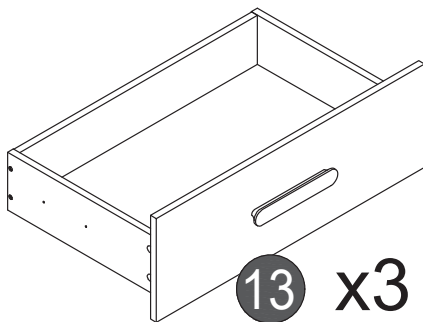

Furniture Anti-Tipping Kit Installation



WARNING

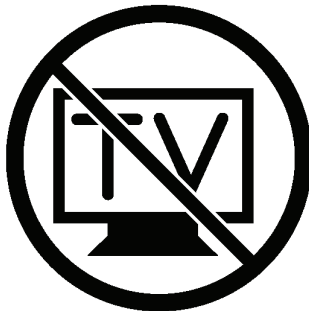

**Children have died from furniture tipover.
To reduce the risk of furniture tipover:**

- ALWAYS install tipover restraint provide.
- NEVER put a TV on this product
- NEVER allow children to stand, climb, or hang on drawers, doors, or shelves.
- NEVER open more than one drawer at a time.
- Place heaviest items in the lowest drawers.

This is a permanent label. Do not remove!

Anti-Tipping Kit

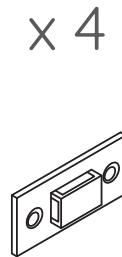
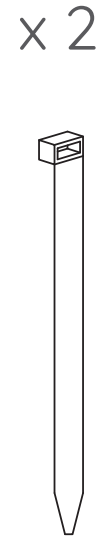

The hardware provided is for masonry or drywall without available wood stud. Please contact your local hardware store if you have questions regarding your wall material.

Tools Required for Assembly (not included)

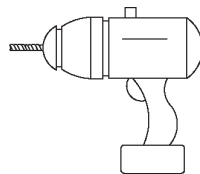
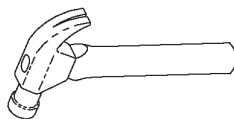
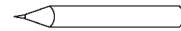
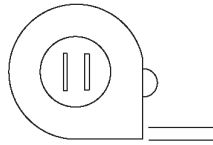
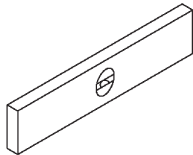

25

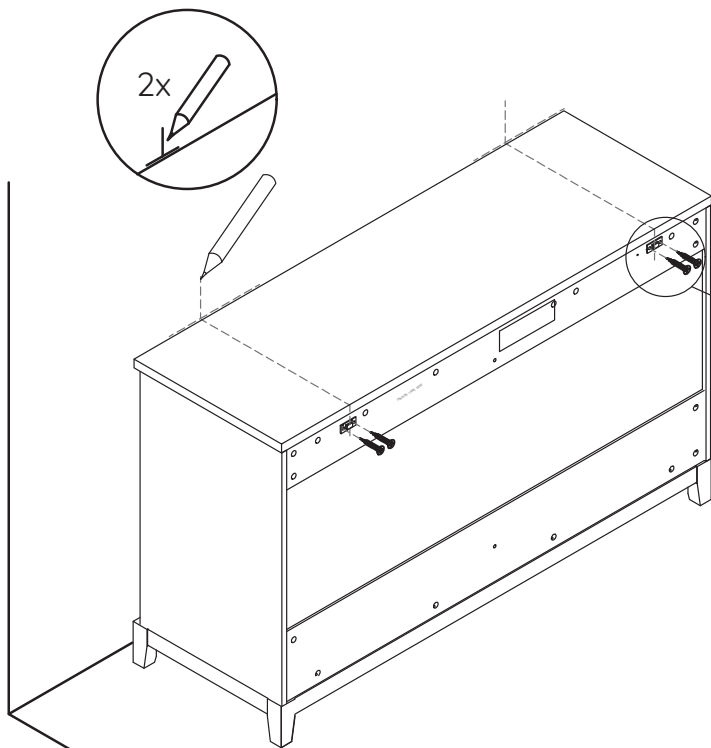

- Attach two brackets securely to the back top rail of the furniture using the short screws provided, through the smaller hole. Then at the appropriate height and positioned over wood stud(s), make two marks with a pencil.

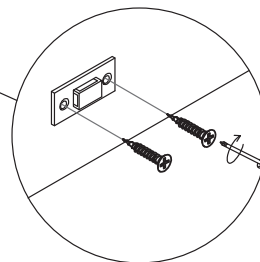

26

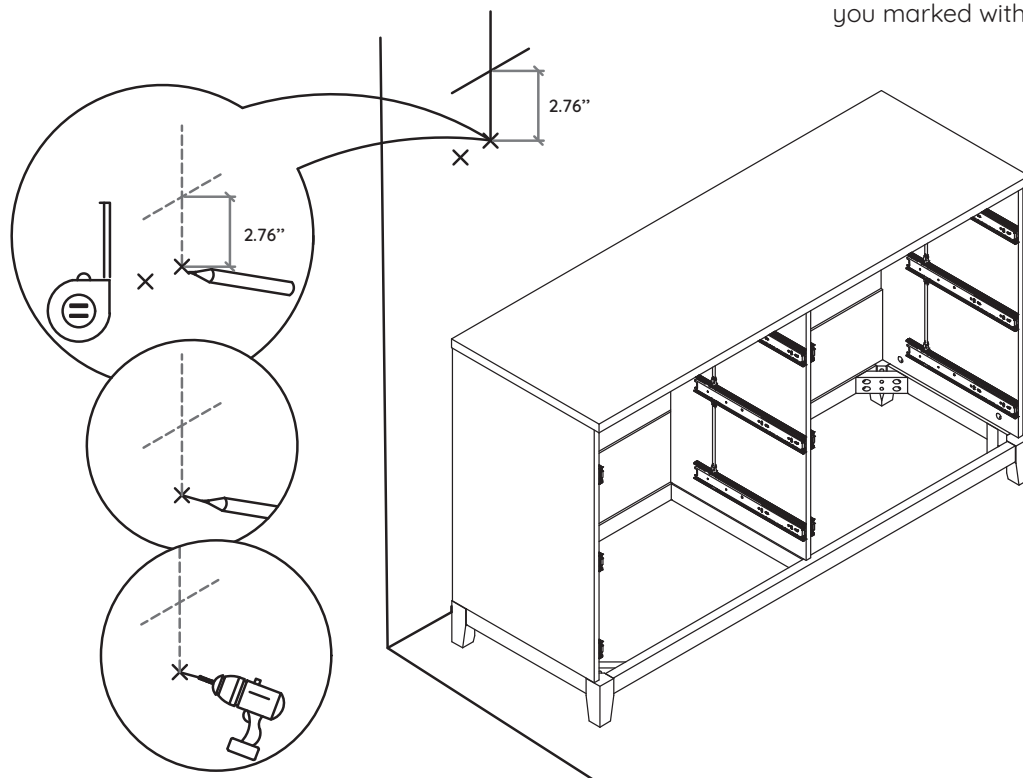

- Drill four 5/16 inch (8mm) diameter holes through the wall at the height you marked with pencil.

27

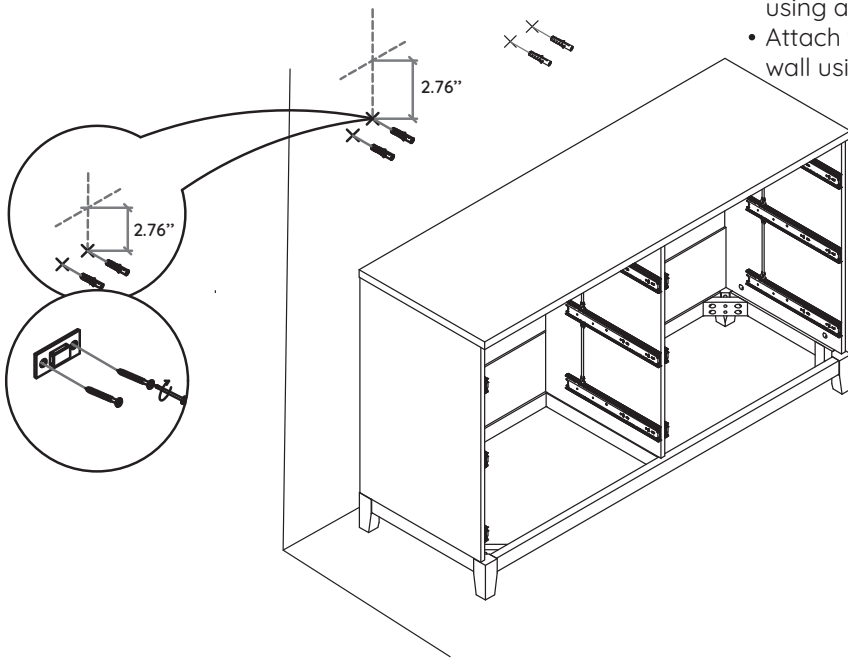

- Drive the plastic plugs into the holes, using a hammer if needed.
- Attach two brackets securely to the wall using the long screws provided.

28

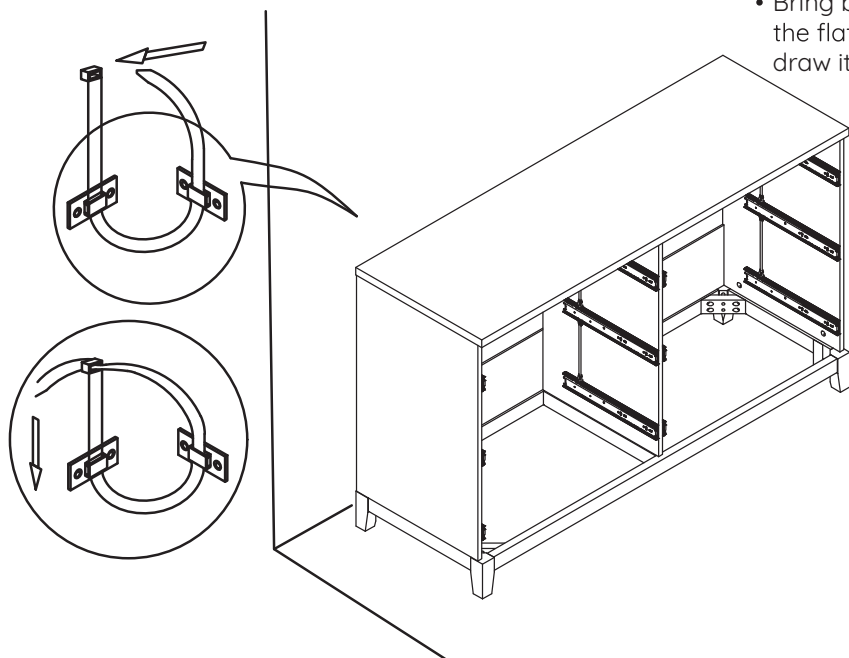

- Move the furniture into its final position.
- Lace the end of the restraint strap through the larger hole in each mounting bracket.
- Bring both ends together and slide the flat end through the locking end and draw it through until all slack is removed.

Only remove one set of runners at a time

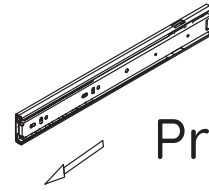
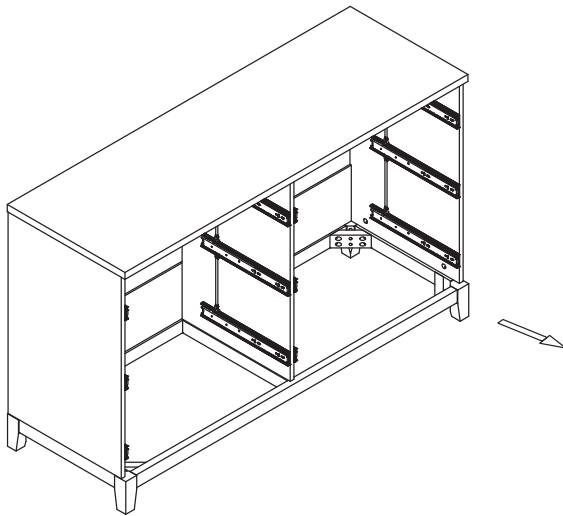

Press & Pull

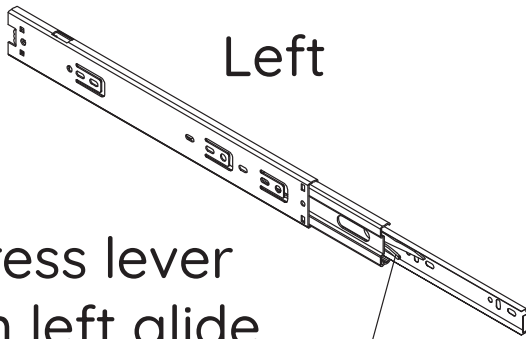
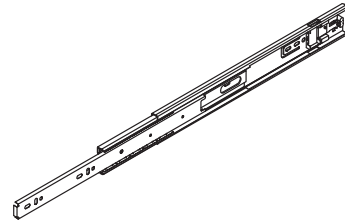

Left

Press lever
on left glide
down

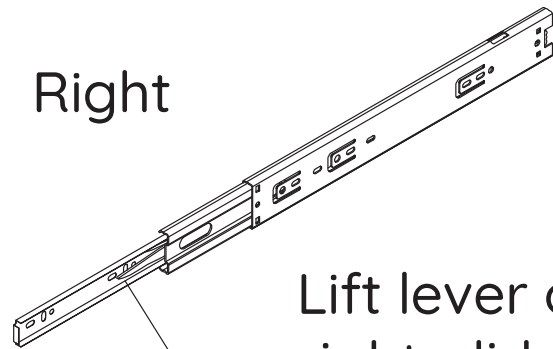
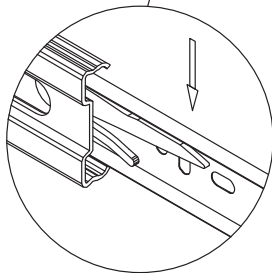

Right

Lift lever on
right glide up

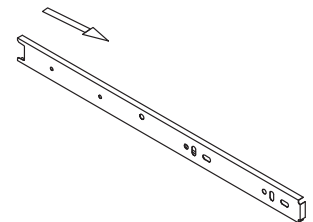
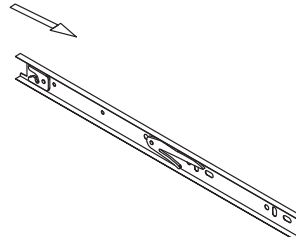
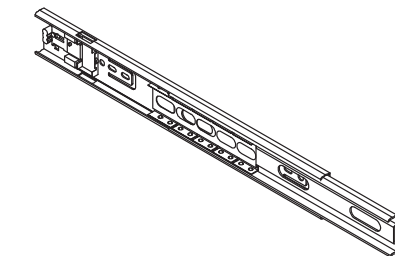
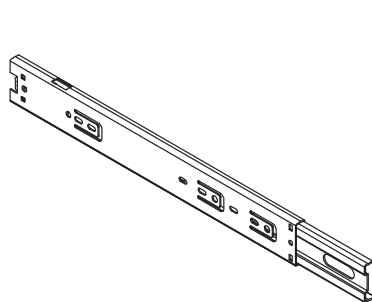
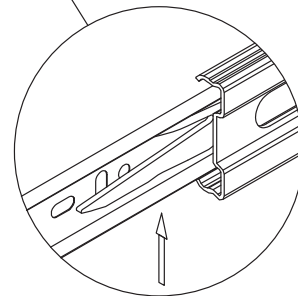

The silver portion of the glide must be pulled to the front of the glide when assembling the drawer into the case.

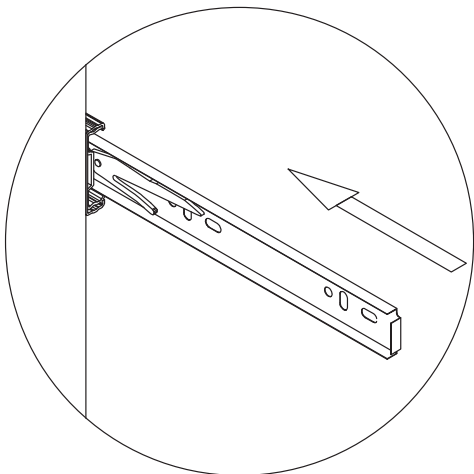
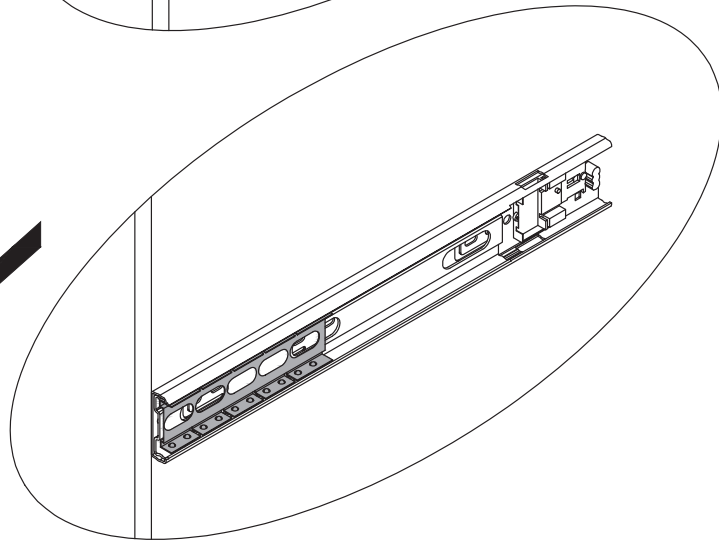
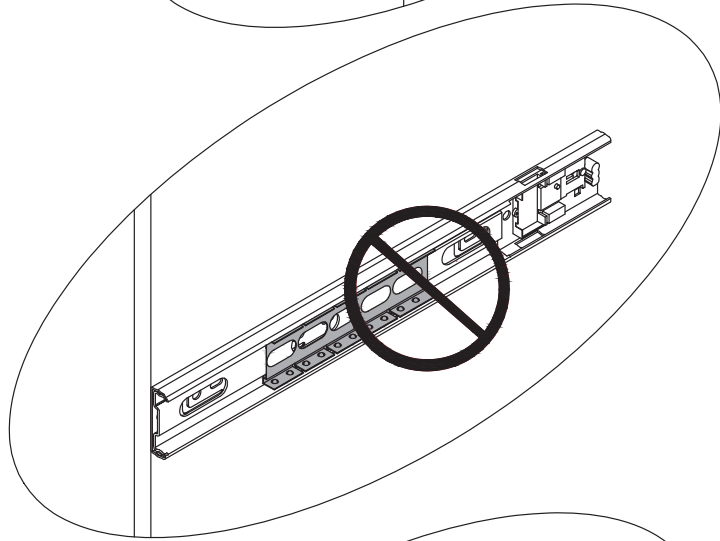
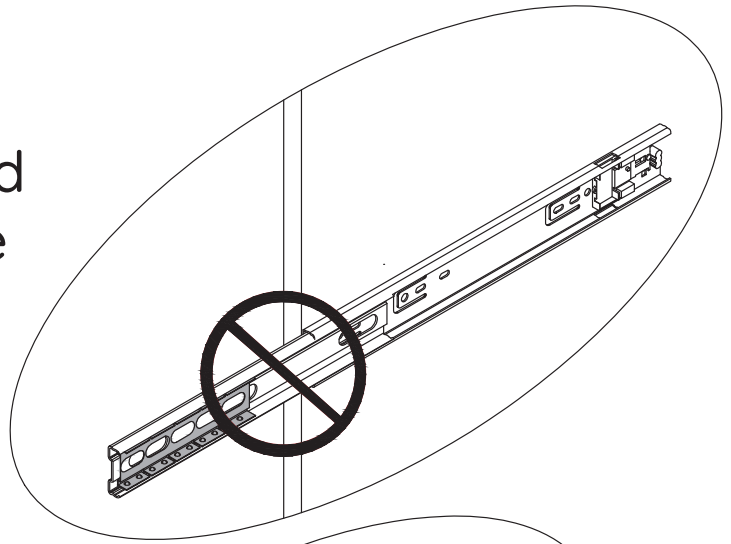

To insert drawer align male runner on drawer to female runner on case and push all the way in

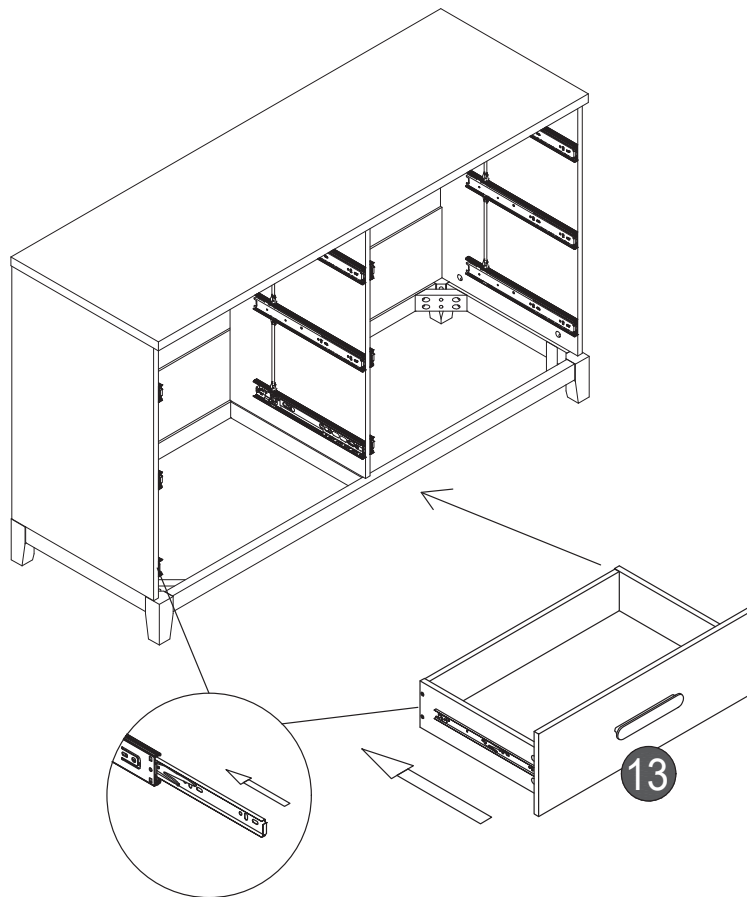
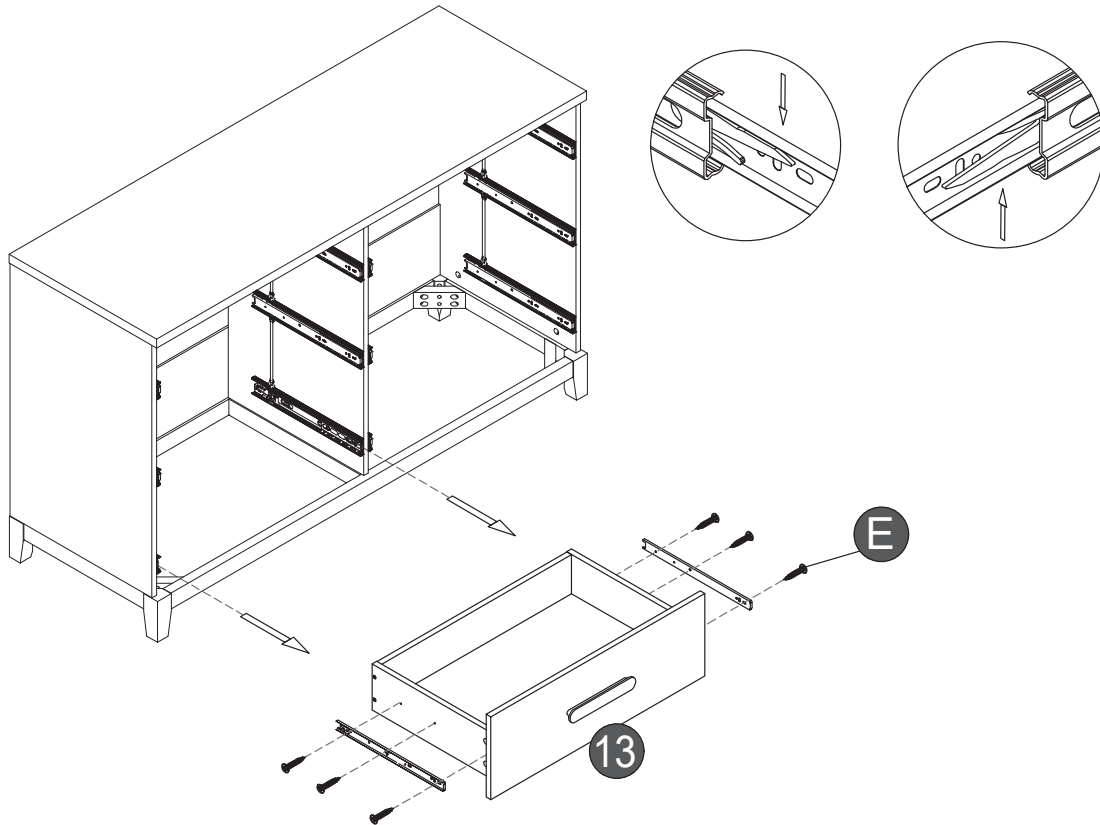

30

E x6 

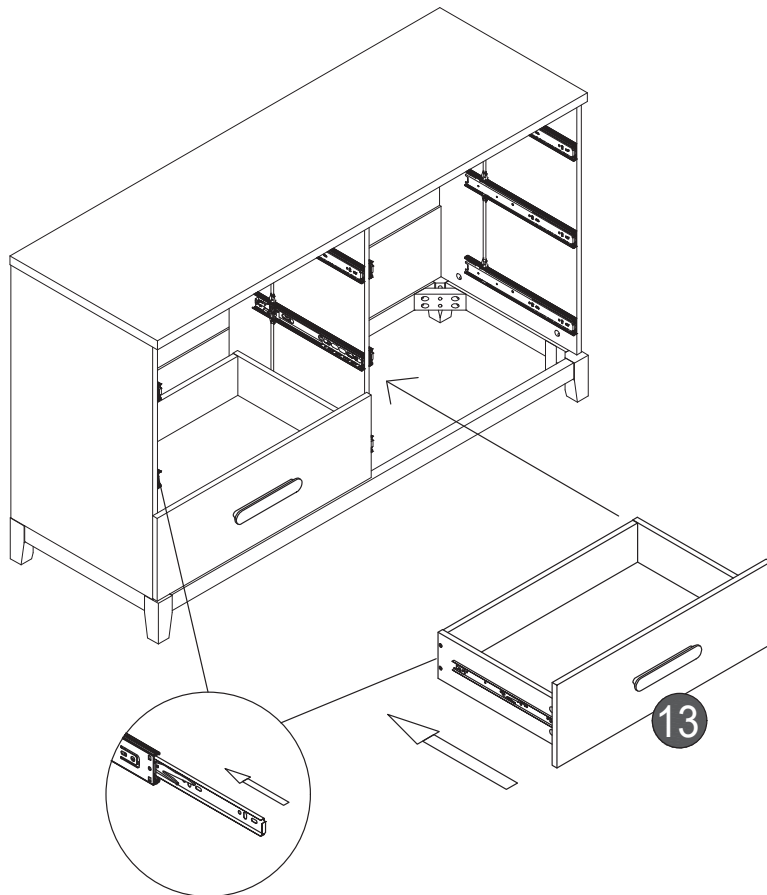
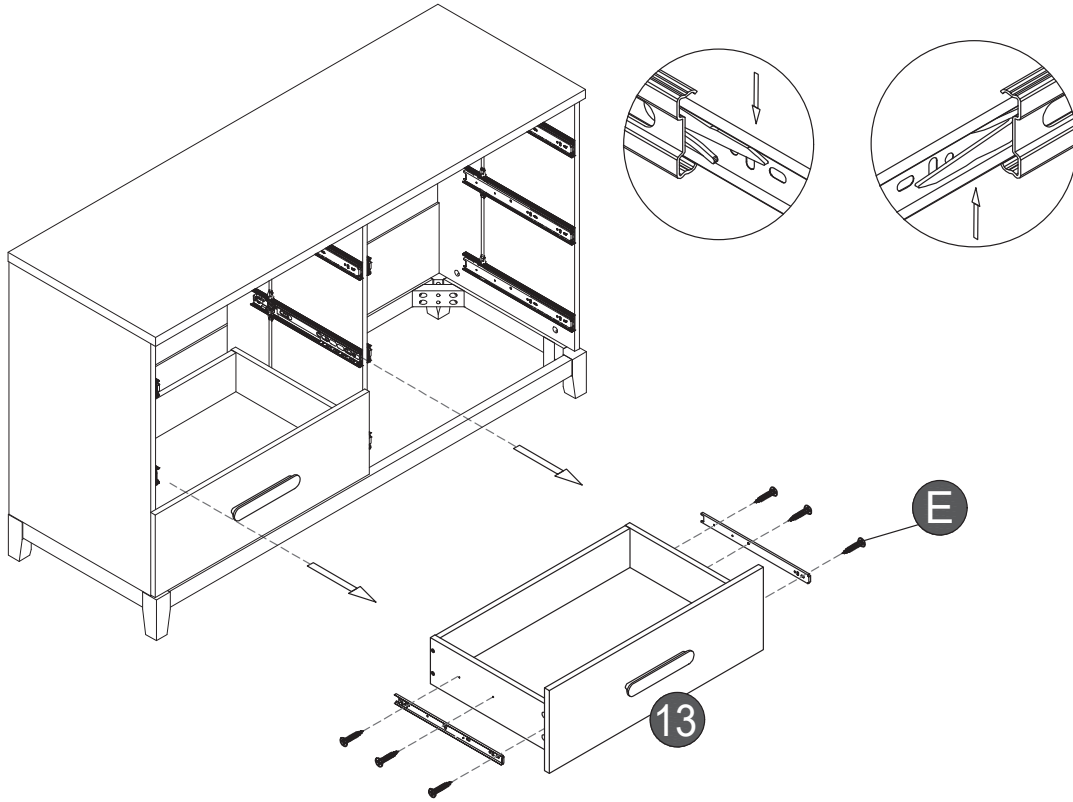

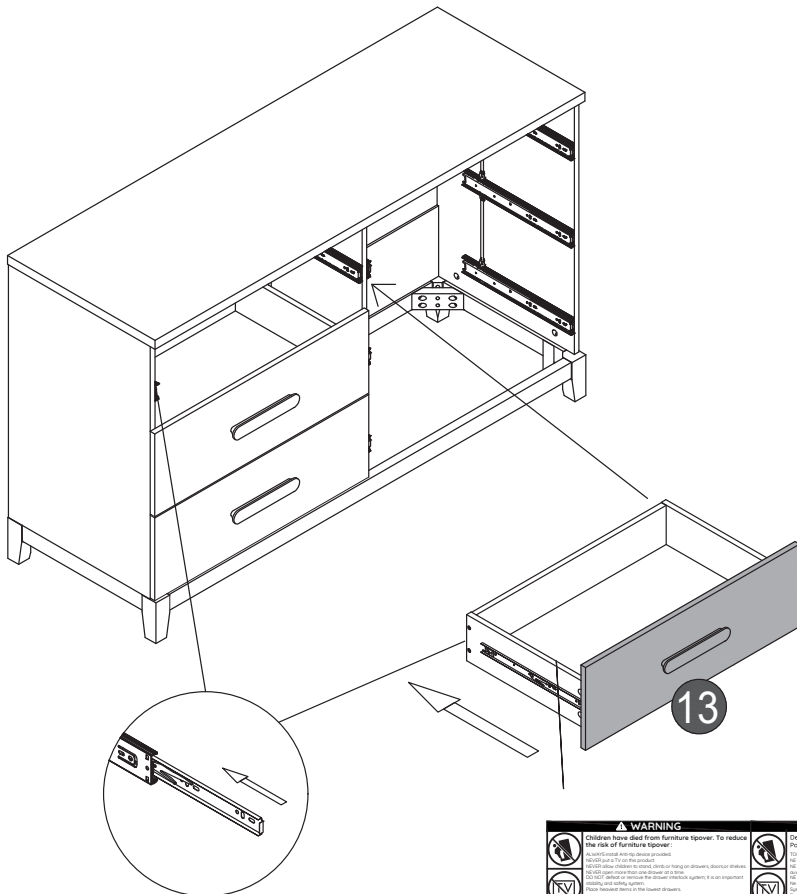
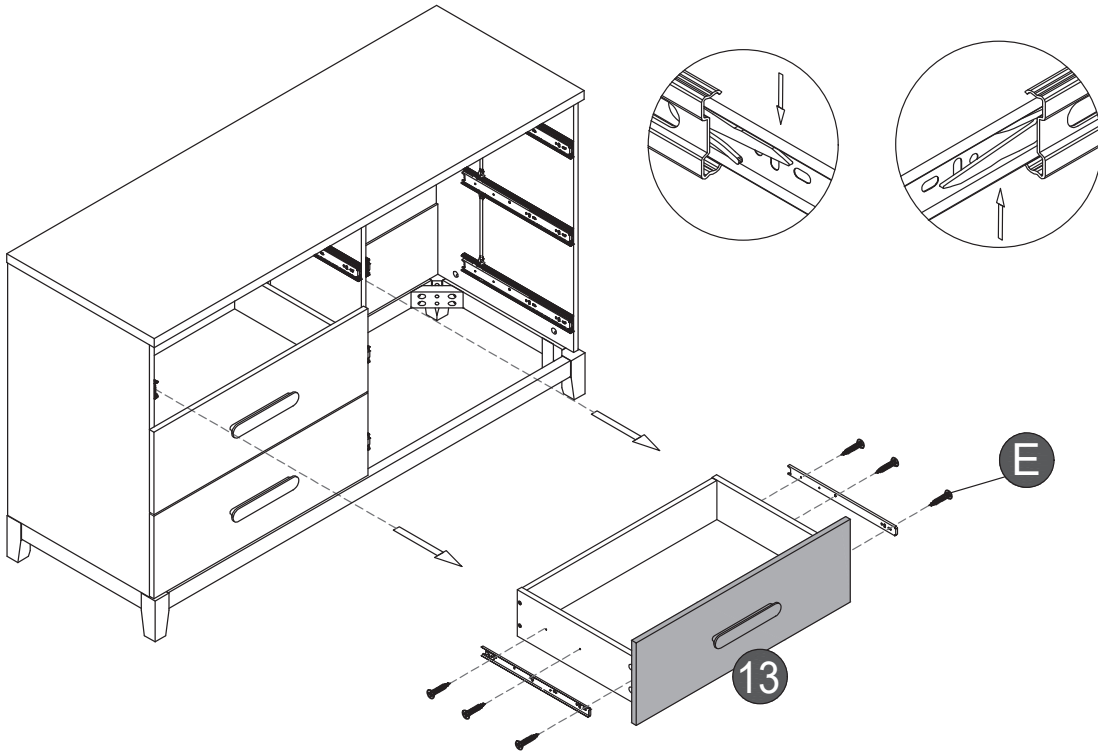

⚠ WARNING		⚠ AVERTISSEMENT	
<p>Children have died from furniture tipover. To reduce the risk of furniture tipover:</p> <ul style="list-style-type: none"> • Always use the correct assembly instructions. • Do not place heavy objects on top of the furniture. • Do not use the furniture as a step or ladder. • Do not use the furniture in areas where children play. • Do not use the furniture in areas where children play. <p>Place furniture firmly in the floor or on a mat.</p> <p><small>This is a permanent alert. Do not remove.</small></p>		<p>Des enfants sont morts à cause d'un meuble qui s'est renversé.</p> <p>Pour réduire le risque de risque de renversement:</p> <ul style="list-style-type: none"> • Utilisez toujours les instructions de montage. • Ne placez pas d'objets lourds sur le meuble. • Ne marchez pas sur le meuble. • Ne placez pas le meuble dans des zones où les enfants jouent. • Ne placez pas le meuble dans des zones où les enfants jouent. <p>Placez fermement le meuble sur le sol ou sur un tapis.</p> <p><small>Cette alerte est permanente. Ne pas retirer.</small></p>	

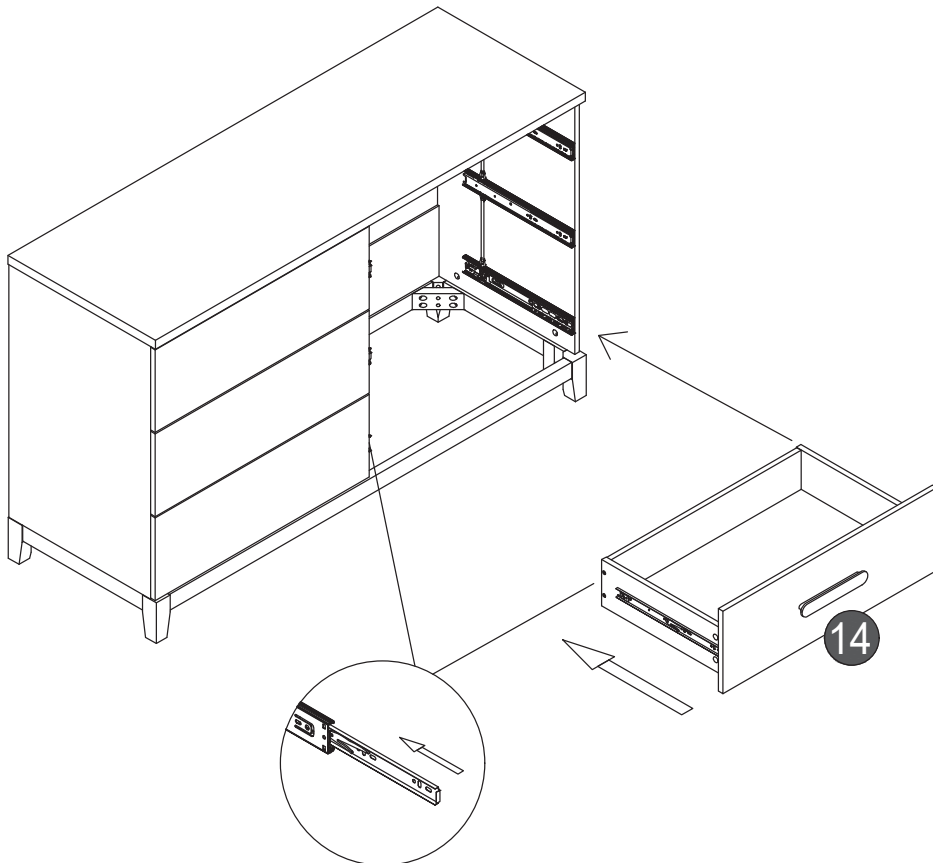
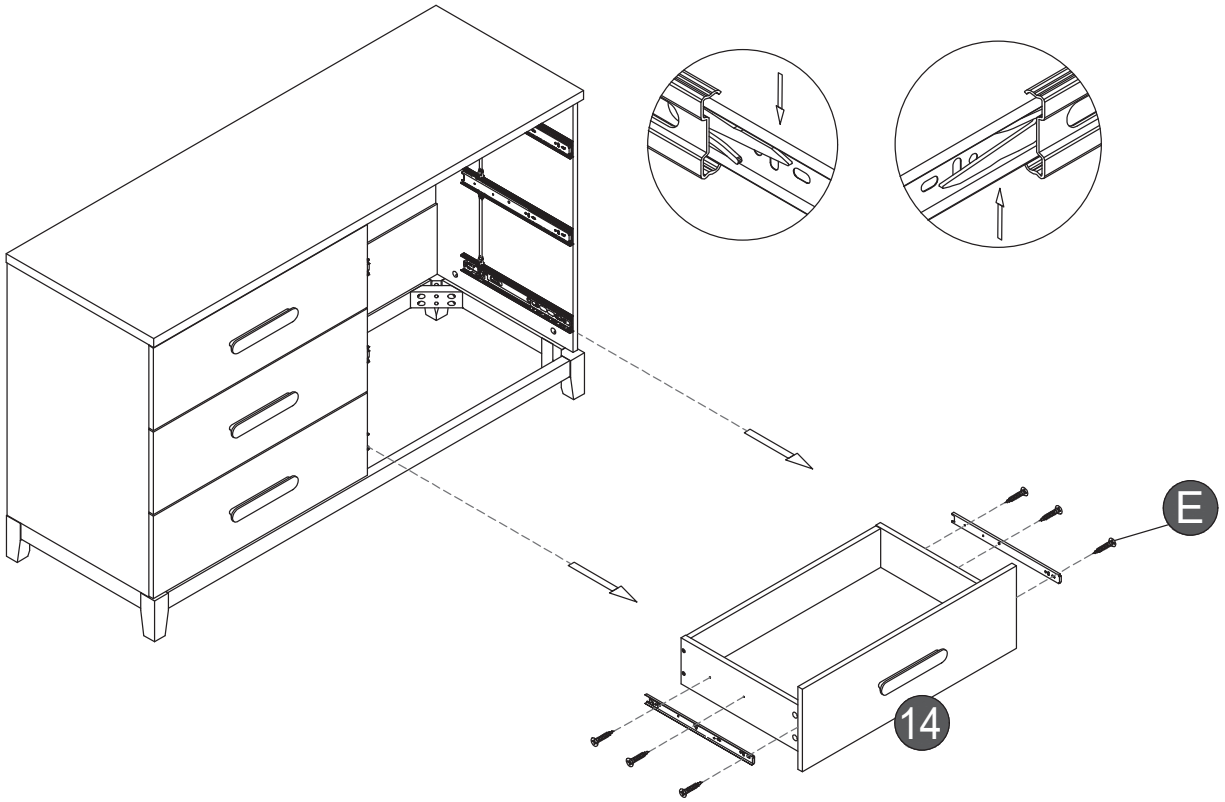

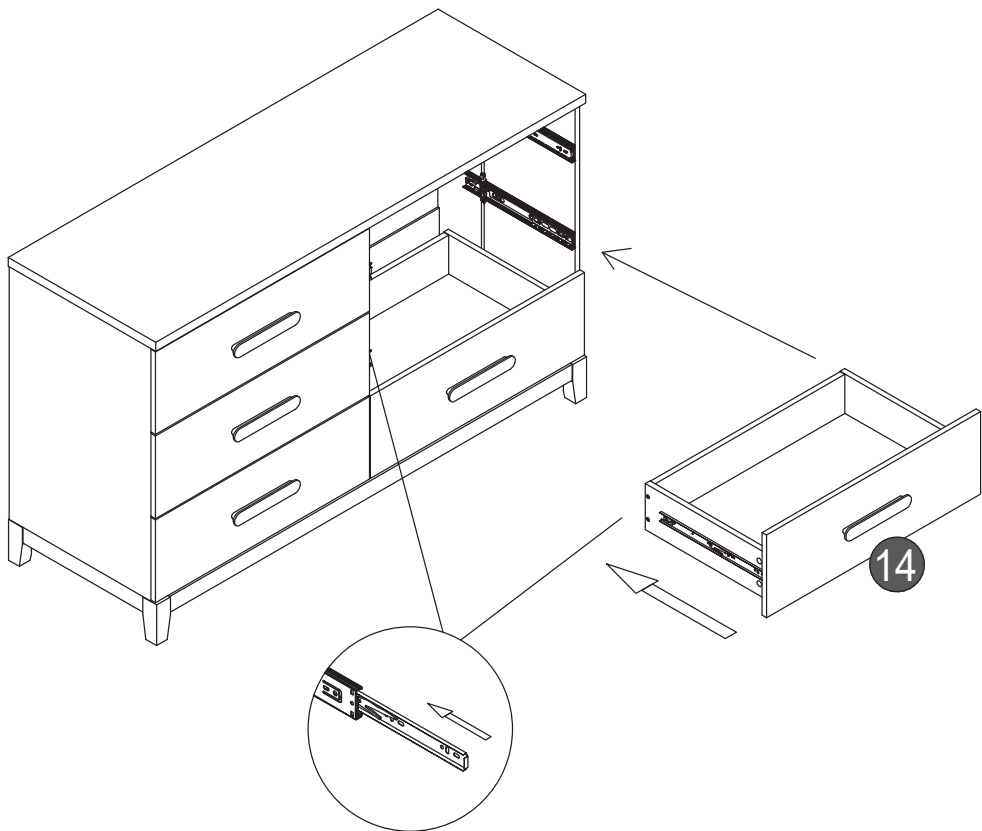
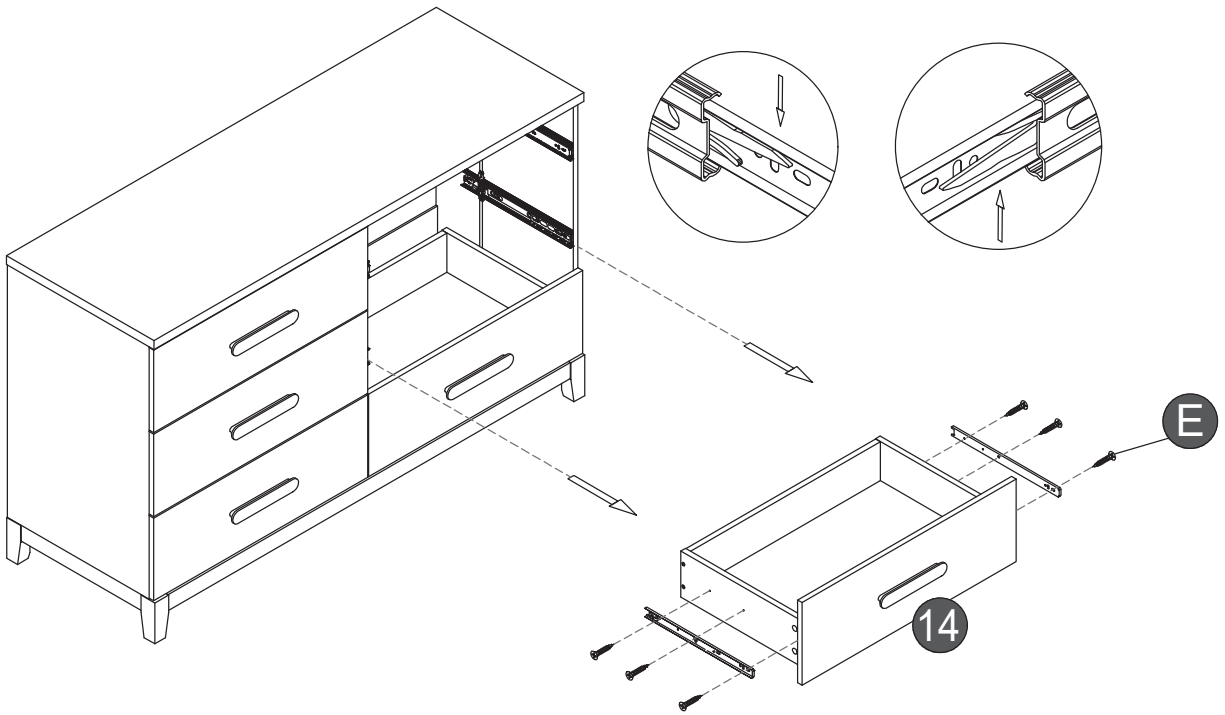

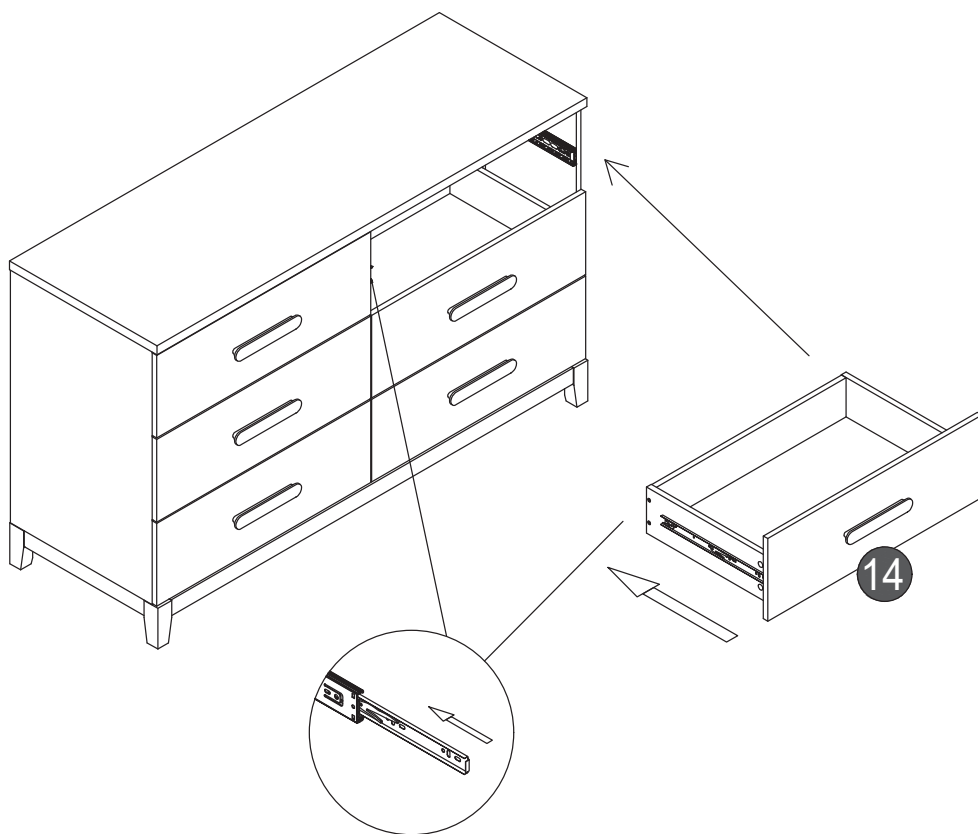
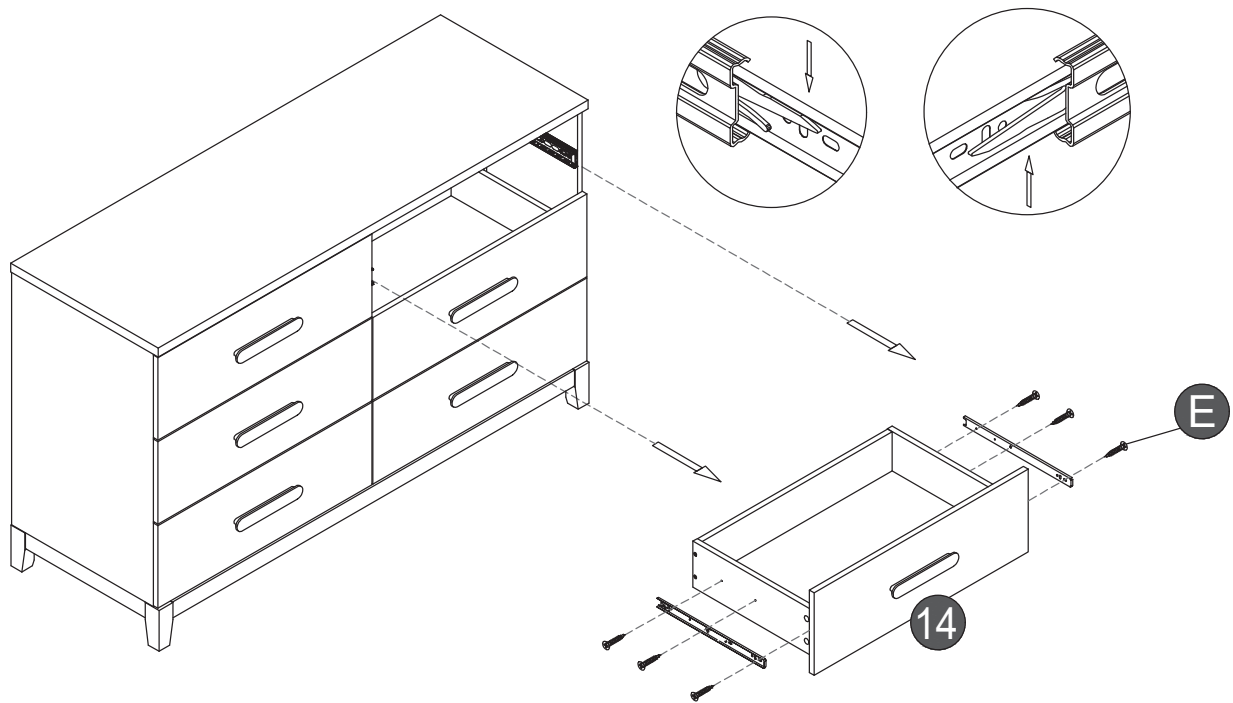

Finish



Thank you
for choosing dadada Baby

We hope you enjoy your new product. We would love to hear about your baby's first moments.

Be sure to tag @dadadababyusa and use #dadadamoments

If there is anything we can improve upon, we would love to know!
You can reach out to our team directly

Website: dadadababy.com
Phone number: (800) 722-5798
Email address: service@dadadababy.com

Care / Cleaning / Maintenance

- Regular care, cleaning, and maintenance will extend the life of your furniture.
- Furniture should not be exposed to direct sunlight, extreme temperatures, or moisture, as this can result in irreparable damage.
- In case of water splashes, remove water immediately and wipe.
- If cleaning is needed, use only a soft, clean cloth, lightly dampened with water.
- Never use abrasive agents or solvents.
- Do not scrub, scratch, or chip the finish.
- Limits of warranty: The use of cleaning agents such as chemicals, scouring powders, or other aggressive formulas can damage the furniture and will void the warranty.

Limited Warranty

- We guarantee this product for a period of 1 year from date of purchase.
- The warranty covers any product failure which may occur due to manufacturing fault.
- The warranty does NOT include normal wear and tear, or parts that are damaged due to incorrect installation and assembly, misuse, or neglect.
- The specific legal rights of this warranty may vary from state to state.
- Some states do not allow any exclusion or limitation of incidental damages.
- Some states do not allow limitation on how long an implied warranty lasts.



1-YEAR WARRANTY



Customer Service

For any missing or faulty parts:

Please re-check your packaging to ensure that parts are missing, then contact our Customer Care team using the contact info below.

Our Care team will need the following information:

- Copy of your receipt
- Model number of the unit purchased
- Description/part number of the missing or faulty part
- Quantity of the parts needed

dadada Customer Care team contact information:

Website: dadadababy.com

Phone number: (800) 722-5798

Email address: service@dadadababy.com

follow us on instagram

@dadadababyusa

