

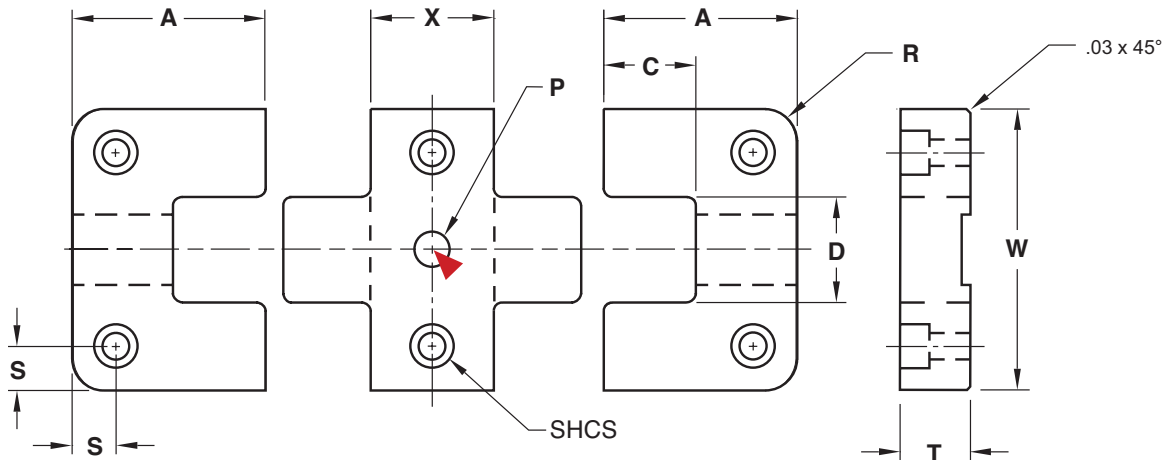

X-STYLE SIDE LOCKS Z-SERIES

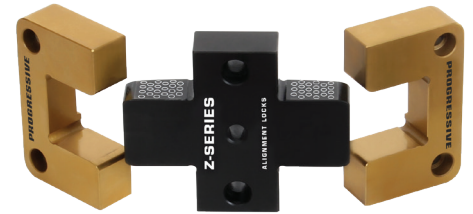

Females (2): **M** D-2 **H** Core: 58-62 HRC, Surface: 80 HRC **S** Titanium Nitride Coated
 Male: **M** H-13 **H** Core: 42-48 HRC, Surface: 70 HRC **S** Salt Bath Nitride

CAD insertion point

CATALOG NUMBER	T +0.00 -0.02	W +0.000 -0.004	X +0.00 -0.02	A +0.00 -0.02	C ±0.01	D .0001/.0003 Clearance Per Side	R Pocket Radius	S ±0.01	P +0.01 -0.00	SHCS
SLX50X87	.500	2.000	.875	1.375	.87	.750	.187	.312	.250	#10-32 x 5/8"
SLX75X137	.750	3.000	1.375	1.875	1.18	1.250	.250	.375	.313	1/4-20 x 3/4"
SLX75X187	.750	3.000	1.875	1.875	1.18	1.250	.250	.375	.313	1/4-20 x 3/4"
SLX100X137	1.000	4.000	1.375	2.375	1.43	1.500	.500	.500	.375	3/8-16 x 1"

Note: 500°F max operating temperature.

Screws included.

For custom Locks, refer to the templates in section X.

SHUTTLE MOLD SETS

Examples of Shuttle Mold configurations:

2 Female Inserts : 1 Male Insert

To order, specify "-SF" after the catalog number of the lock.
 Examples: SL50X200-SF GL100X150-SF TL75X125-SF TL50X100-R-SF
 CF31X62-SF CRSM08-SF

2 Male Inserts : 1 Female Insert

To order, specify "-SM" after the catalog number of the lock.
 Example: SL75X300-SM GL250X450-SM TL112X200-SM TL150X250-R-SM
 CF31X62-SM CRSM08-SM

Individual males and females and special configurations (Ex. 4M:1F) are available.
 Contact Customer Service for pricing and availability.





SIDE/TOP/GUIDE LOCK SELECTION GUIDE

Refer to the chart below to match the correct alignment lock for the corresponding mold size and weight of B-Side and press platen, using four locks per mold. Clean and lubricate lock every 100,000 cycles, and prevent corrosion during mold storage.

RECOMMENDED MAX MOLD SIZE (LXWXH)	SIDE LOCKS	METRIC SIDE LOCKS	GUIDE LOCKS	TOP LOCKS	TOTAL MAX WEIGHT B SIDE + PRESS PLATEN (LBS/KG)
RTI AND MOLDS 8 X 8 X 8 AND SMALLER	SL37X100, SL50X125 SL50X150, SL50X200 SLS62X150, SLS62X200 SLR50X125, SLR50X150	SLM16X50, SLP16X20 SLPM16X40, SLP20X25 SLPM20X50, SLM13X38 SLMS16X50	GL100X150 GLM25X45	TL50X100, TL62X125 TL75X125, TLM26X35 TLR87X150	2,000 / 900
11 X 16 X 10	SL50X125, SL50X150 SL50X200, SLS62X150 SLS62x200, SLS75X300 SLS75X400, SLR50X150 SLR50X200	SLM16X50, SLMS19X75 SLPM25X32, SLP25X63 SLPM32X40, SLP32X80 SLPM40X50 SLPM40X100 SLMS19X100	GL100X150 GL150X250 GLM25X45	TL62X125, TL75X125 TLM26X35 TLR87X150 TLR112X200	5,000 / 2,300
16 X 24 X 16	SL50X150, SL50X200 SL75X300, SLS112X500 SLS75X300, SLS75X400 SLR75X300, SLR100X400	SLM19X75, SLM19X100 SLMS25X125 SLPM50X56, SLP50X112 SLRM32X63, SLRM40X100	GL150X250 GLM40X65	TL75X125, TL87X150 TLM26X35, TLM30X45 TLR112X200 TLR150X250	7,000 / 3,200
28 X 34 X 24	SL75X300, SLS112X500	SLM19X75, SLM19X100	GL200X350 GL150X250 GLM40X65	TL100X150, TL100X200 TL112X200, TL112X300 TLM26X35, TLM30X45	10,000 / 4,500
32 X 40 X 28	SL100X400	SLM25X125	GL200X350 GLM40X65	TL112X200, TL112X300 TLM36X55, TLM36X75	15,000 / 6,800
42 X 48 X 34	SL125X500		GL250X450 GLM50X90	TL150X250, TL175X300 TLM36X55, TLM36X75	20,000 / 9,000
48 X 52 X 38	SL150X600		GL250X450	TL175X300, TL200X350 TLM45X100	26,000 / 11,800

BAR LOCK SELECTION GUIDE

BAR CATALOG NUMBER	GUIDE CATALOG NUMBER	BAR LOCK ENGAGEMENT	TOTAL MAX WEIGHT SUPPORTED (LBS/KG)
BLB100L4	BLG100L1.3, BLG100L1.8	2.50	15,000 / 6,800
BLB100L6	BLG100L2.3, BLG100L2.8	4.50	
BLBM25L125	BLGM25L27, BLGM25L36	89 mm	15,000 / 6,800
BLB125L5	BLG125L1.3, BLG125L1.8	3.00	20,000 / 9,000
BLB125L9	BLG125L2.3, BLG125L2.8	7.00	
BLBM32L160	BLGM32L36, BLGM32L46	114 mm	20,000 / 9,000
BLB137L6	BLG137L1.8, BLG137L2.3	3.50	23,000 / 10,400
BLB137L11	BLG137L2.8, BLG137L3.3, BLG137L3.8	8.50	
BLBM38L250	BLGM38L46, BLGM38L76	194 mm	26,000 / 11,800
BLB150L8	BLG150L1.8, BLG150L2.3	4.50	26,000 / 11,800
BLB150L16	BLG150L2.8, BLG150L3.3, BLG150L3.8	12.50	
BLN150L8	BLG150L1.8, BLG150L2.3 BLG150L2.8, BLG150L3.3, BLG150L3.8	3.75	25,000 / 11,340
BLN250L10	BLG250L4.3	5.00	50,000 / 22,500
BLN350L13	BLG350L4.8	6.00	75,000 / 34,000

