

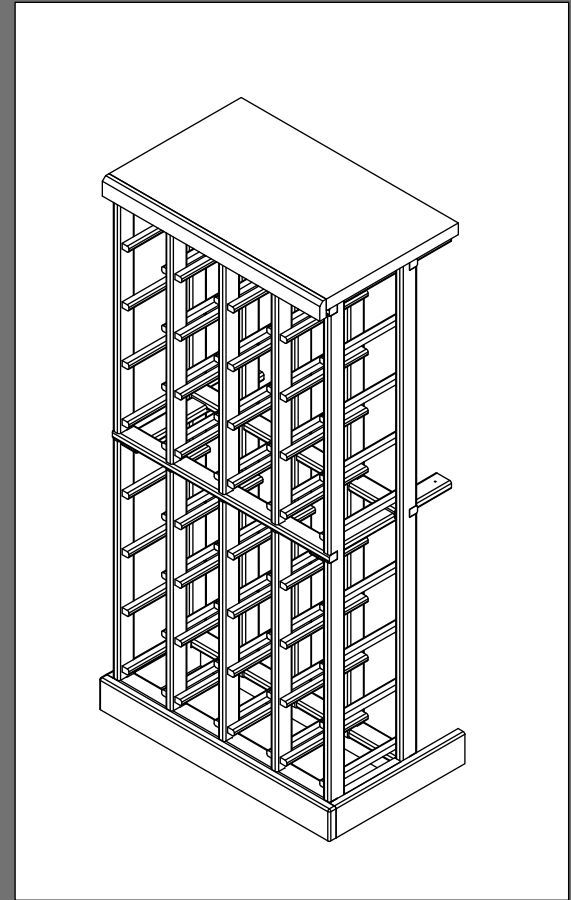

ASSEMBLY INSTRUCTIONS



FOR KIT RACKS:

- TASTING TABLE 16 32

INTRODUCTION

Thank you for purchasing a KIT RACK by Genuwine Cellars. The following instructions will help you assemble kits:

TASTING TABLE 16 32

Please study the instructions carefully prior to starting the assembly.

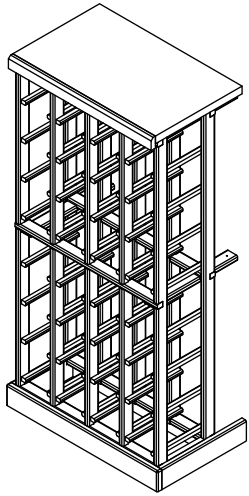

COMPONENTS

The following components are included in Tasting Table 32 32

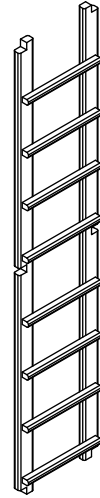

SIDE LADDERS

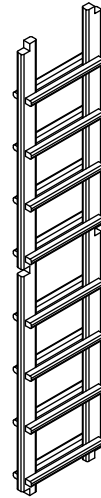

MIDDLE LADDERS

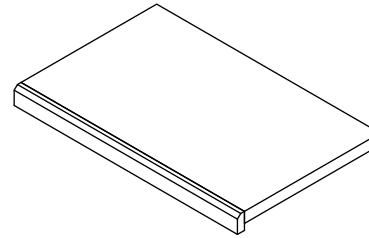

COUNTER TOP

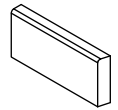

BASE MOULD FRONT & SIDE

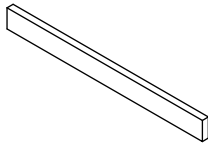

BASE BLOCK

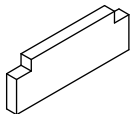

BASE SIDES

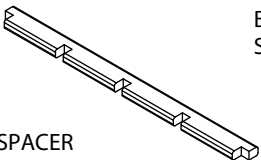

SPACER BARS

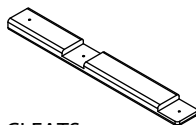

CLEATS

QUANTITY OF COMPONENTS

COMPONENT	QTY
SIDE LADDER	2
MIDDLE LADDER	3
COUNTER TOP	1
SPACER BARS	6
BASE SIDES	2
BASE BLOCKS	2
BASE MOULD FRONT	1
BASE MOULD SIDES	2
CLEATS	4

TOOLS REQUIRED

The following tools are required (NOT INCLUDED):

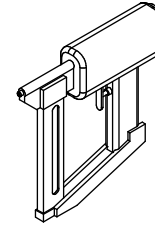

NAIL GUN
(with appropriate air compressor or electric nailer)
18 gauge brand nails (supplied)



WOOD GLUE

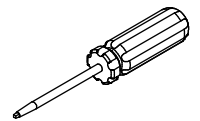

PHILIPS HEAD SCREWDRIVER

IMPORTANT!
Always follow the manufacturer's instructions on how to use the nail gun to prevent injury. Genuwine Cellars is not liable for any injury incurred by any power or hand tool used to assemble the kit.

HARDWARE

The following hardware is included in all kits:

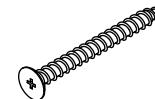

• Philips Flathead 1 1/2"
QTY: 4



• Philips Flathead 1/2"
QTY: 4

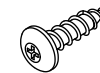

• Philips Panhead 5/8"
QTY: 8



• **DRYWALL ANCHORS (4)**

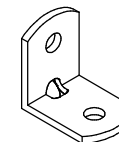

• **ANGLED BRACKETS (4)**

• **GAUGE BRAD NAILS (6 SLEEVES)**

ASSEMBLY- IB RACKS

STEP 1 APPLY GLUE TO SPACER BARS

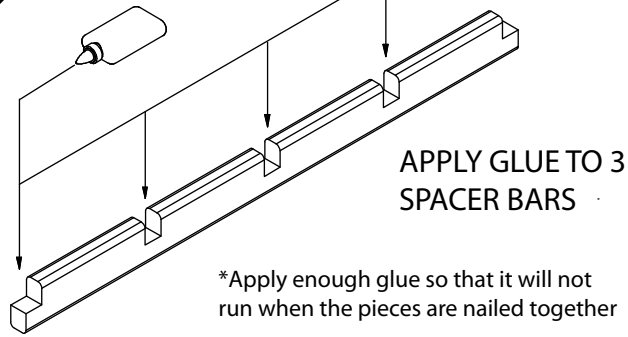

STEP 3 APPLY GLUE TO CLEATS

APPLIE GLUE TO 4 CLEAT NOTCHES

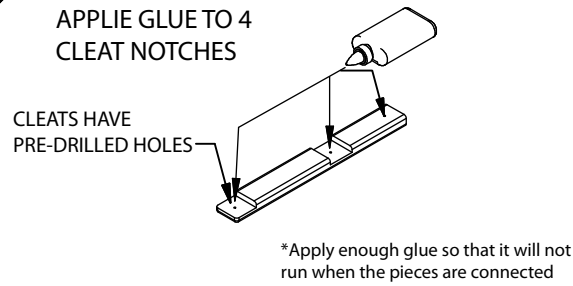

STEP 2

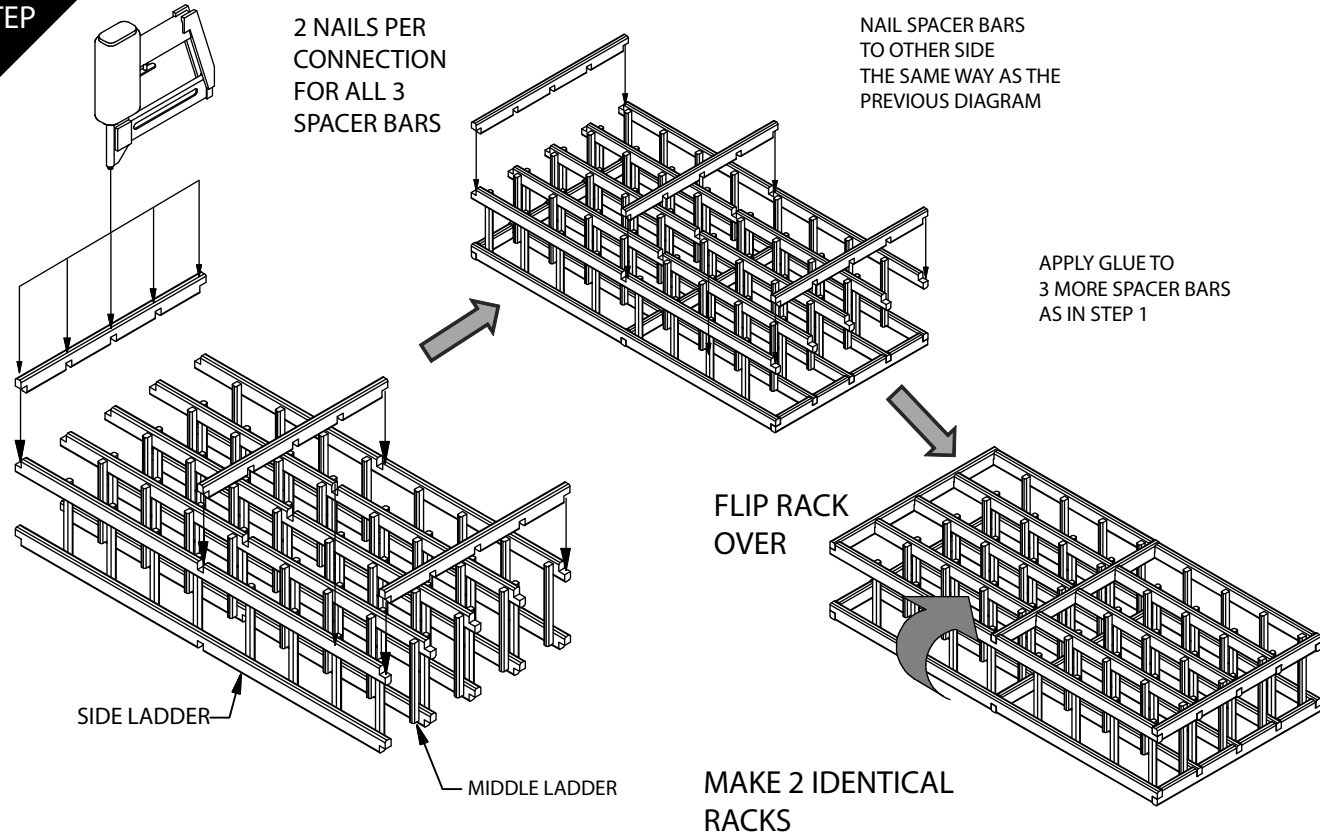

STEP 4

TURN RACK OVER ON ITS TOP SPACER BARS

PLACE CLEATS AT THESE LOCATIONS

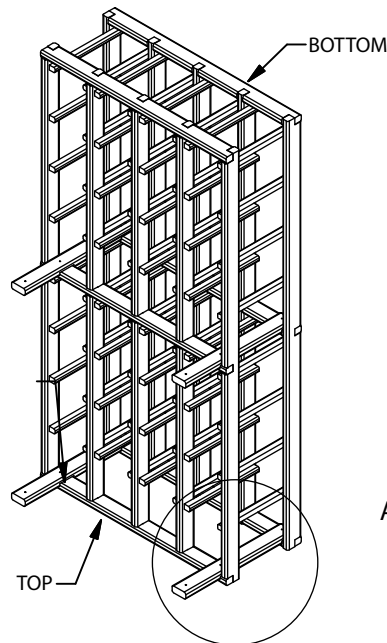

SCREW CLEATS TO SPACER BARS AS SHOWN

Philips Panhead 5/8"

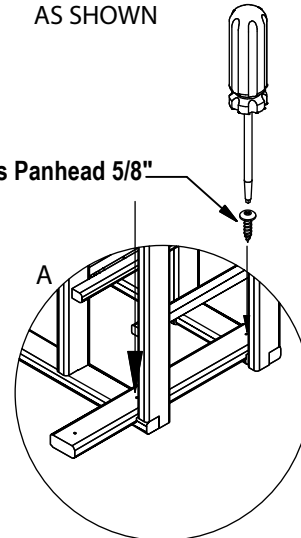

ASSEMBLY- BASE

STEP 1

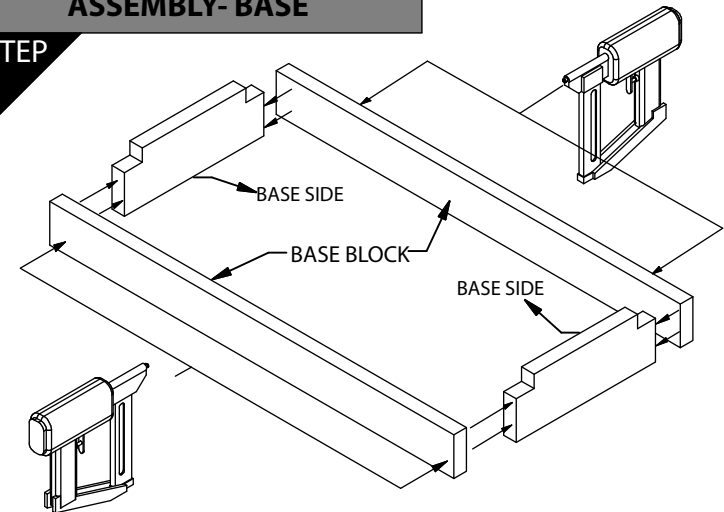

MAKE 3-4 NAILS PER CONNECTION
2 IDENTICAL BASES

STEP 2 ATTACH BASE MOULDS

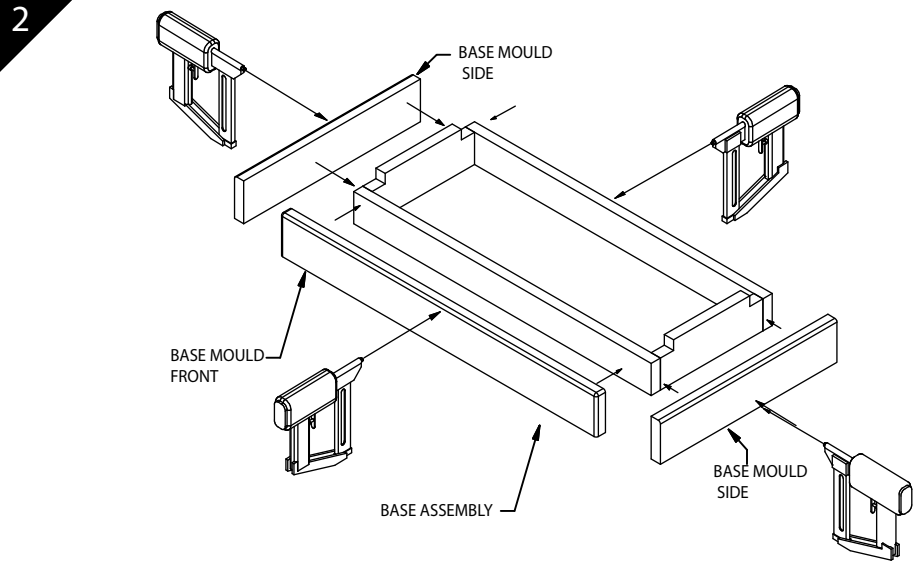

FINISHED BASE ASSEMBLY

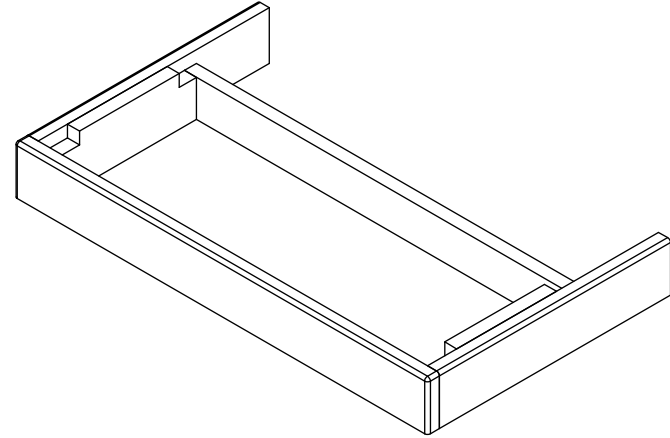

TASTING TABLE ASSEMBLY

STEP 1 B

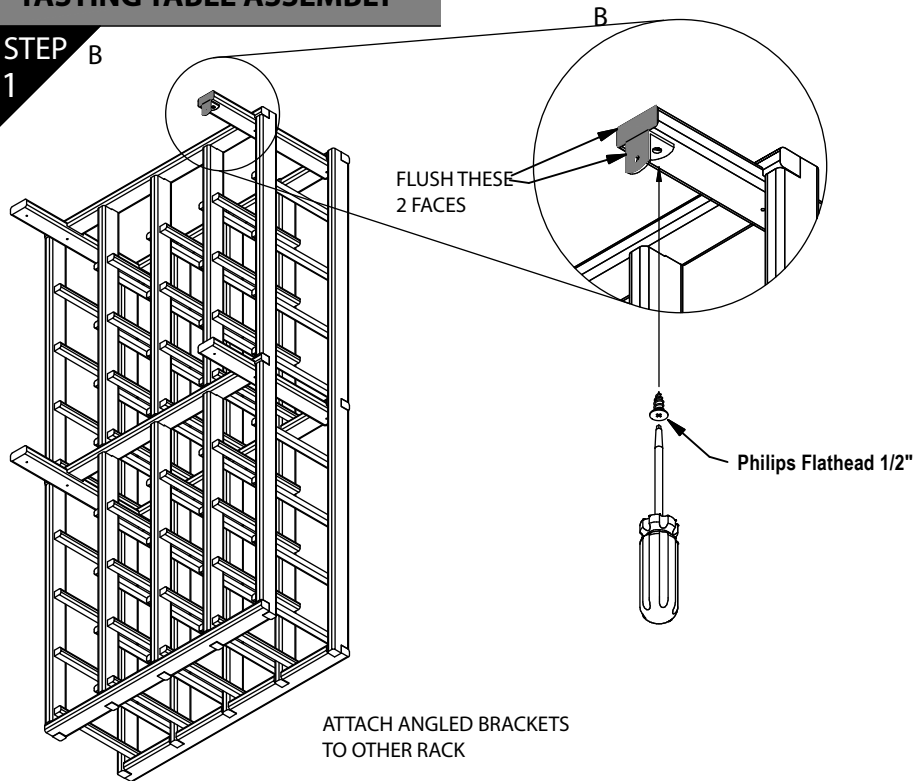

STEP 2

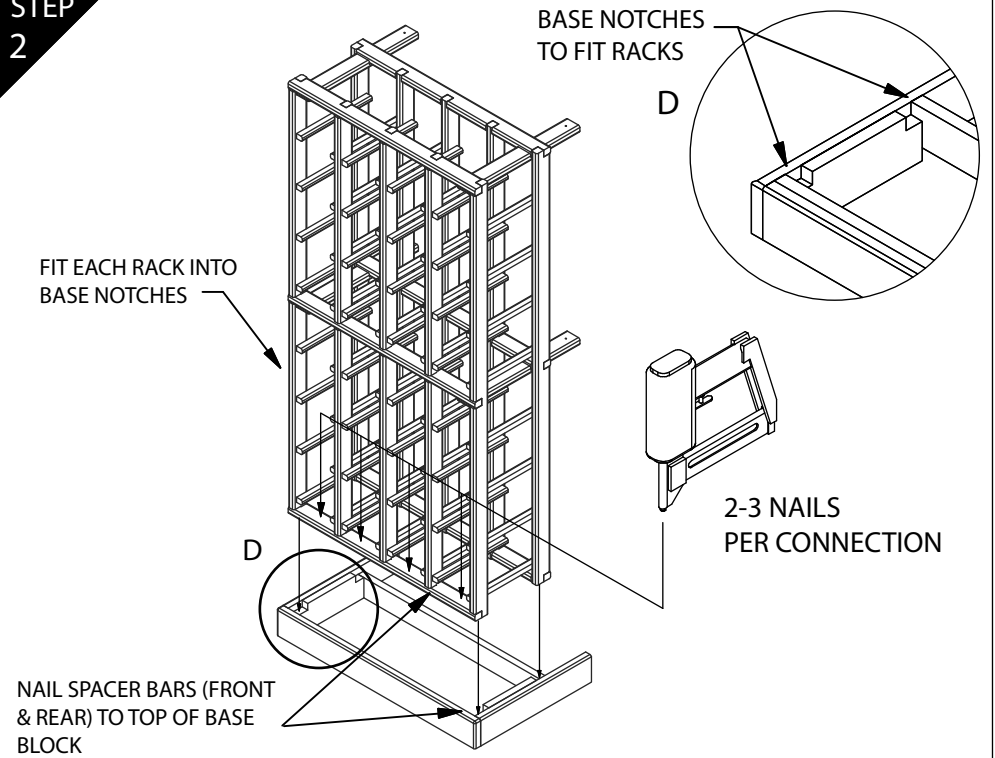

STEP
3

PLACE COUNTERTOP
ON RACKS

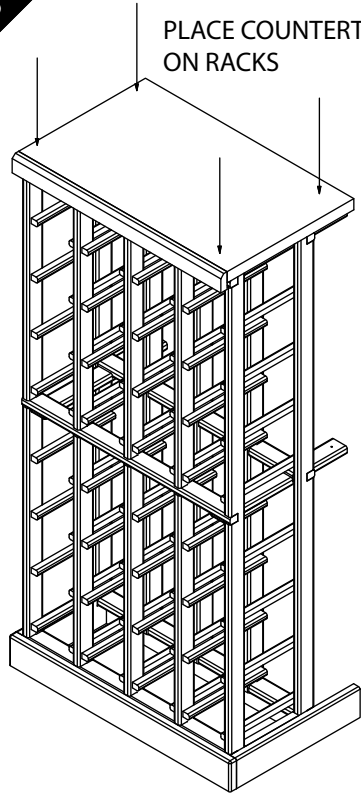

PLACING THE COUNTERTOP

STEP
4

PLACE NAIL THROUGH
TOP SPACER BAR AT
THESE LOCATIONS

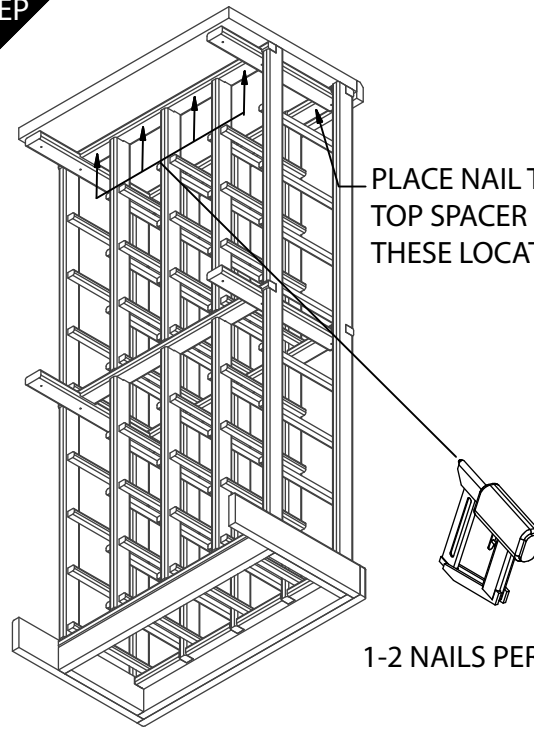

1-2 NAILS PER LOCATION

VIEW OF TASTE TABLE FROM UNDERNEATH TO
SHOW LOCATIONS OF NAILS

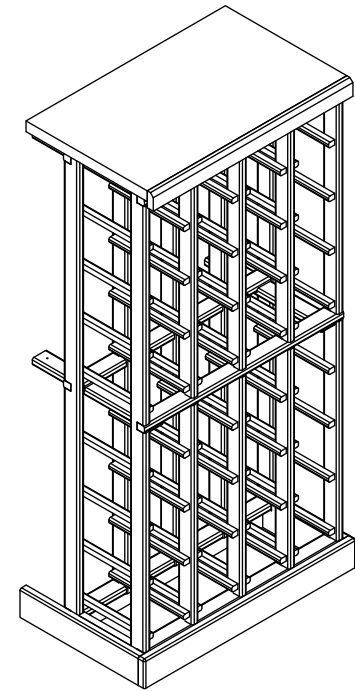

**TASTING TABLE 16 32 ASSEMBLY
IS COMPLETED**