

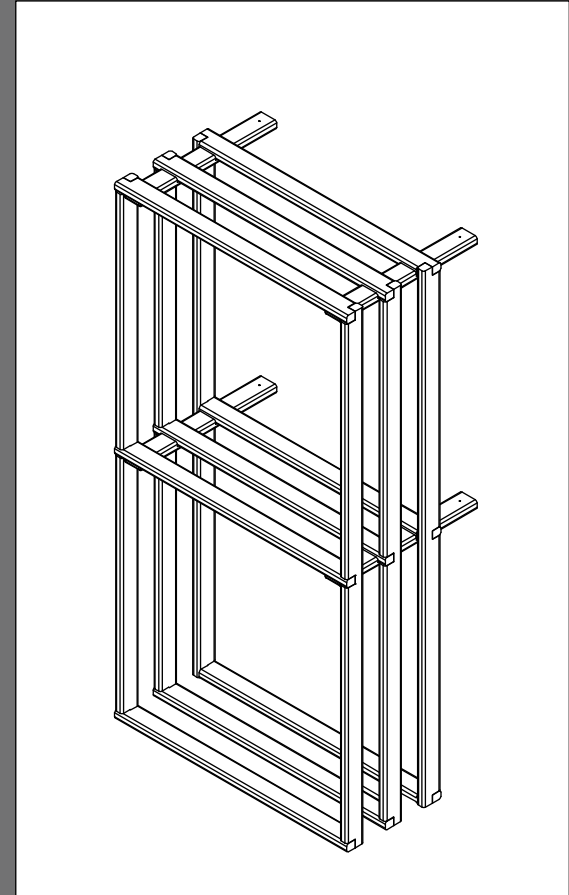

ASSEMBLY INSTRUCTIONS



FOR KIT RACKS:

- BIN16 32
- BIN16 48
- BIN32 32
- BIN32 48
- BURGUNDY 16 32
- BURGUNDY 16 48
- CHAMPAGNE 16 32
- CHAMPAGNE 16 48
- WOODCASE 16 32
- WOODCASE 16 48

INTRODUCTION

Thank you for purchasing a KIT RACK by Genuwine Cellars. The following instructions will help you assemble kit number BIN 16 32. The same procedure can be followed to assemble kits BIN 16 48, BIN 32 32, BIN 32 48, BURGUNDY 16 32, BURGUNDY 16 48, CHAMPAGNE 16 32, CHAMPAGNE 16 48, WOOD CASE 24 32, WOOD CASE 24 48

Please study carefully the instructions prior to starting the assembly.

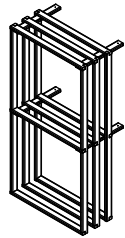

BIN 16 32

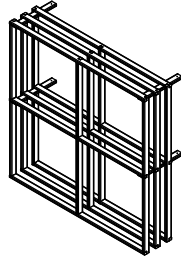

BIN 32 32

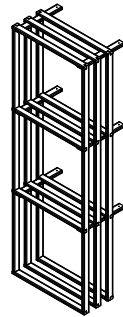

BIN 16 48

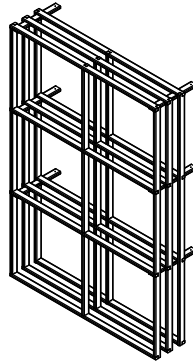

BIN 32 48

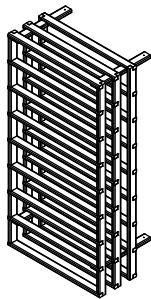

BURGUNDY 16 32

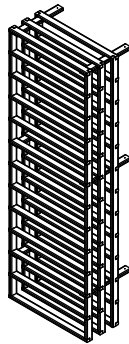

BURGUNDY 16

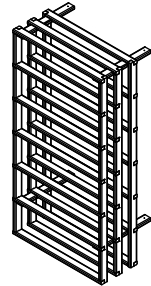

CHAMPAGNE 16 32

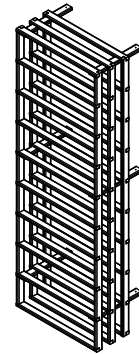

CHAMPAGNE 16 48

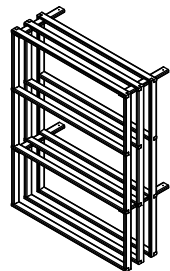

WOOD CASE 24 32

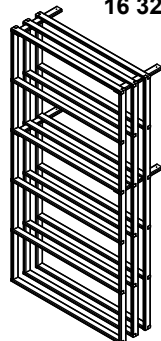

WOOD CASE 24 48

TYPE

- Philips Flathead 1 1/2" QTY: 4



- Philips Flathead 1/2" QTY: 4



- Philips Panhead 5/8" QTY: 12



COMPONENTS

The following components are included in kit:

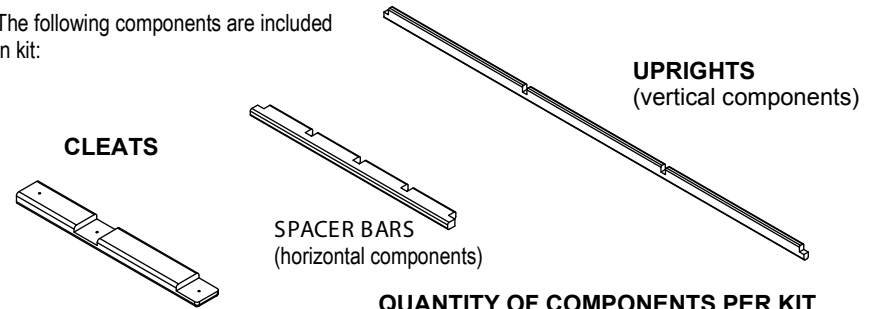

QUANTITY OF COMPONENTS PER KIT

KIT NUMBER	COMPONENT		
	SPACER BARS	UPRIGHTS	CLEATS
BIN 16 32	9	6	4
BIN 32 32	N/A	18	4
BIN 16 48	12	6	4
BIN 32 48	12	9	4
BURGUNDY 16 32	27	6	4
BURGUNDY 16 48	39	6	6
CHAMPAGNE 16 32	21	6	4
CHAMPAGNE 16 48	30	6	6
WOOD CASE 24 32	12	6	4
WOOD CASE 24 48	18	6	4

HARDWARE

The following hardware and quantity is included in kit:
(NOTE: Quantity vary in kit)

- ANGLED BRACKETS QTY: 4

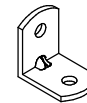

- DRYWALL ANCHORS QTY: 4



- BRAD NAILS 18 GAUGE (3 SLEEVES)

TOOLS REQUIRED

The following tools are required (NOT INCLUDED):

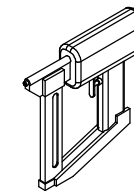

NAIL GUN (with appropriate air compressor or electric nailer)
For 18 gauge brand nails (supplied)

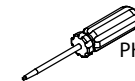

PHILIPS HEAD SCREWDRIVER



WOOD GLUE

IMPORTANT!
Always follow the manufacturer's instructions on how to use the nail gun to prevent injury. Genuwine Cellars Inc. is not liable for any injury incurred by any power tool or tool used to assemble the kit

ASSEMBLY

STEP 1

ASSEMBLE "LADDERS"

NAIL SPACER BARS TO UPRIGHTS

1-2 NAILS PER CONNECTION

APPLY GLUE TO UPRIGHT NOTCHES

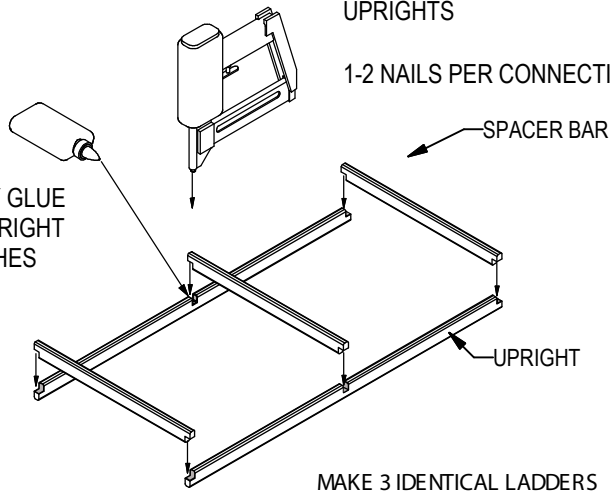

MAKE 3 IDENTICAL LADDERS

STEP 5

PLACE 3 MORE CLEATS

FOLLOW STEP 3 TO ATTACH 3 MORE CLEATS IN THE POSITIONS SHOWN ON THE DIAGRAM

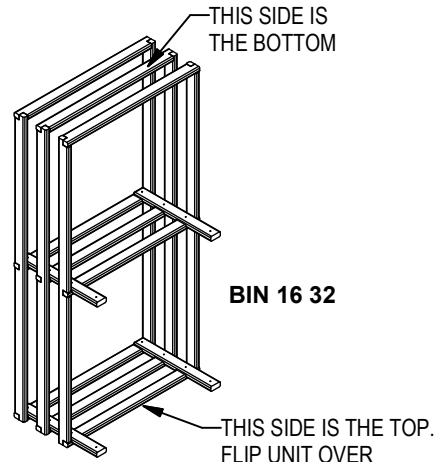

BIN 16 32

NOTE:

Placement of the cleats depends on the kit you purchased. See the diagrams below to determine the position of the cleats according to your kit.

STEP 2

APPLY GLUE TO CLEAT NOTCHES

APPLY GLUE SPARINGLY TO FIRST NOTCHE

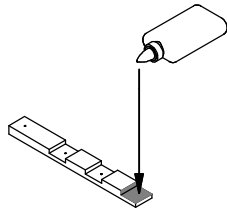

STEP 4

PLACE 2 REMAINING LADDERS INTO CLEAT NOTCHES

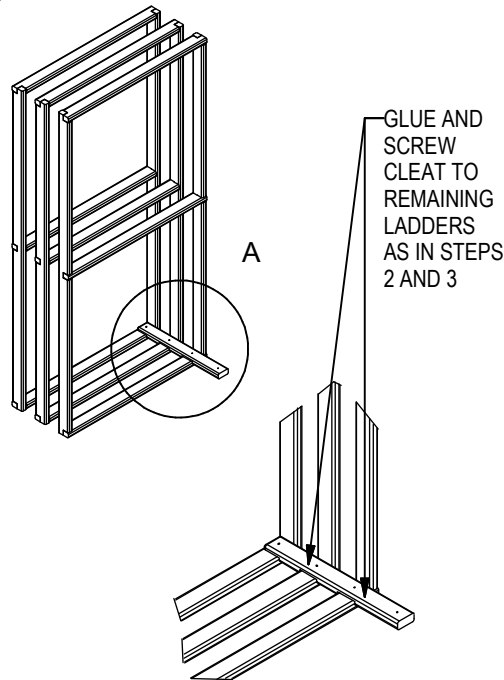

A

A

STEP 3

SCREW CLEAT TO LADDER

Philips Panhead 5/8"

CLEAT WITH PRE-DRILLED HOLES AND GLUE APPLIED

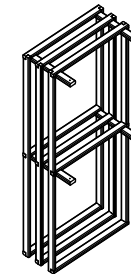
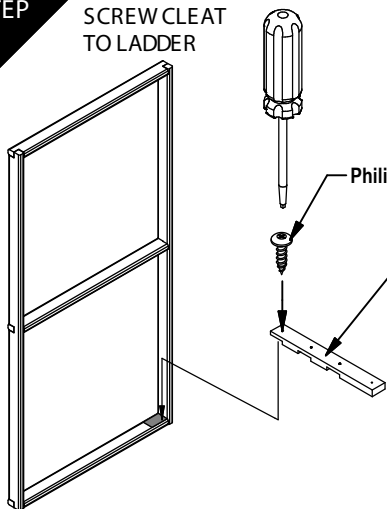

BIN 16 32

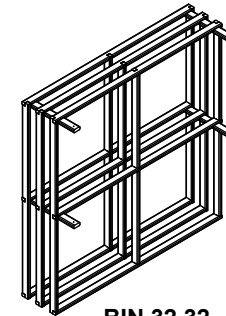

BIN 32 32

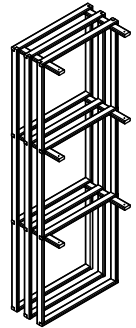

BIN 16 48

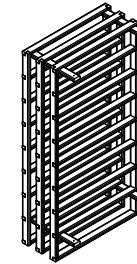

BURGUNDY 16 32

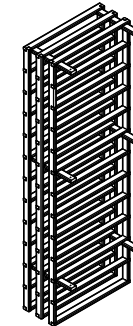

BURGUNDY 16 48

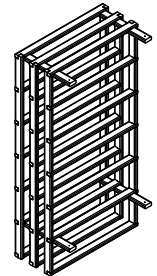

CHAMPAGNE 16 32

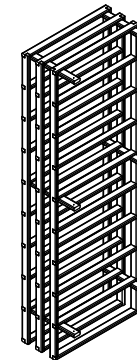

CHAMPAGNE 16 48

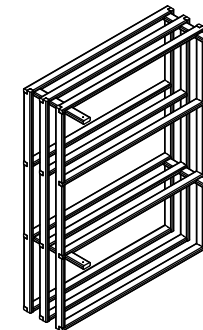

WOOD CASE 24 32

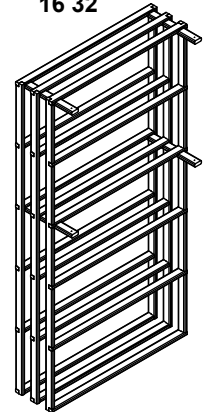

WOOD CASE 24 48

STEP 6

SCREW ANGLED BRACKETS TO EACH CLEAT

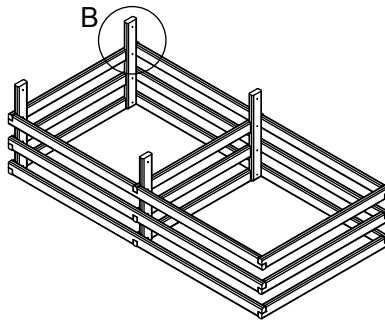
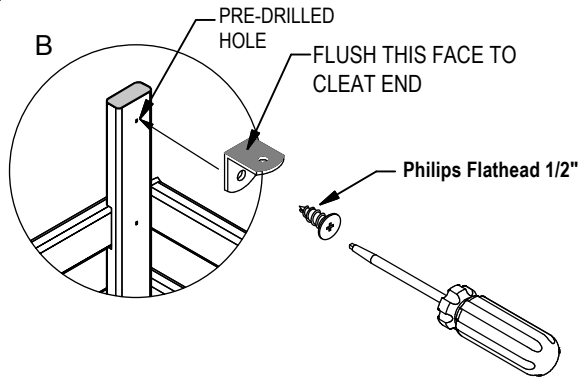

**AT THIS POINT THE BIN IS COMPLETED
FOLLOW STEP 6 IF THIS UNIT REQUIRES
A BASE ASSEMBLY
FOLLOW STEP 7 FOR ASSEMBLING TO
OTHER UNITS AND MOUNTING TO WALL**

STEP 7

ATTACHING BASE ASSEMBLY (sold separately)

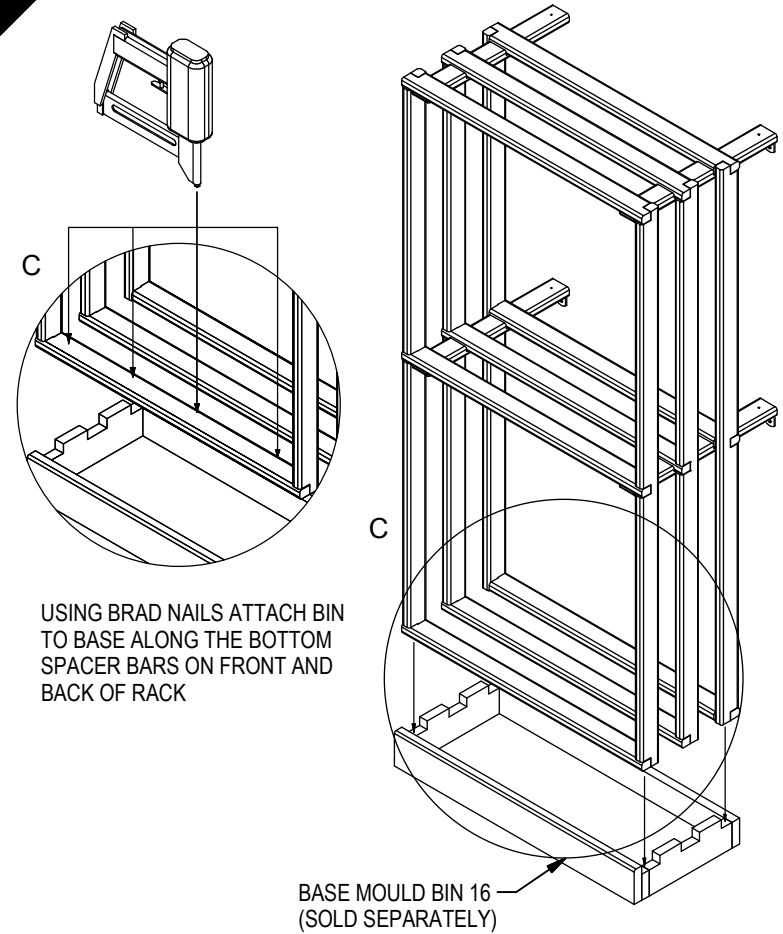

STEP 8

ATTACHING COMPLETED UNIT TO WALL AND OTHER UNITS

USE NAIL GUN TO ATTACH UNITS TO EACH OTHER

3 - 4 NAILS PER SIDE

MULTIPLE UNITS MAY BE STACKED TO REACH DESIRED HEIGHT

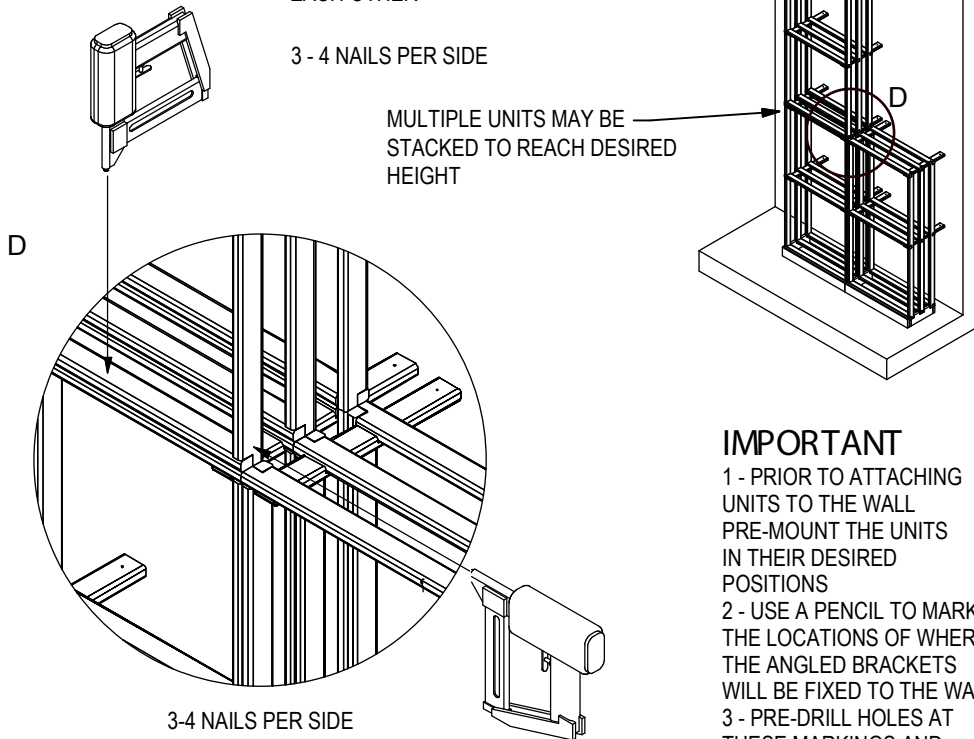

IMPORTANT

- 1 - PRIOR TO ATTACHING UNITS TO THE WALL PRE-MOUNT THE UNITS IN THEIR DESIRED POSITIONS
- 2 - USE A PENCIL TO MARK THE LOCATIONS OF WHERE THE ANGLED BRACKETS WILL BE FIXED TO THE WALL
- 3 - PRE-DRILL HOLES AT THESE MARKINGS AND INSTALL THE DRYWALL ANCHORS PROVIDED WITH THE KIT

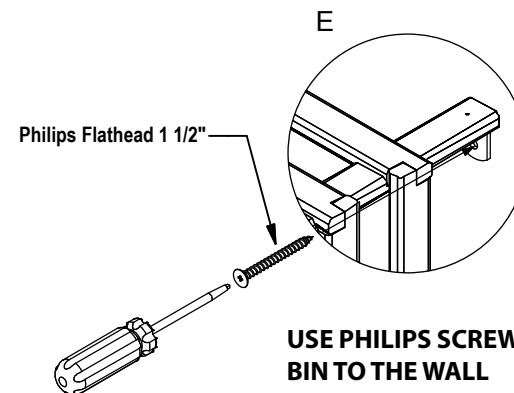

**STEP
8**

ATTACHING CROWN MOULD TO BIN

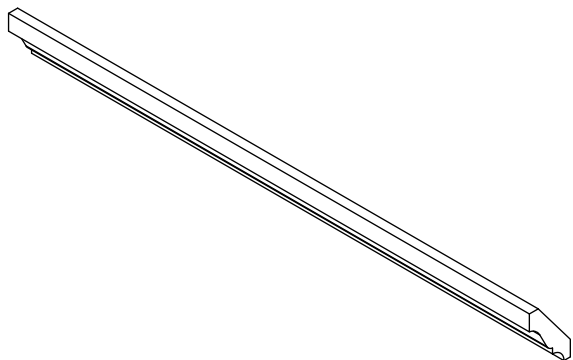

***NOTE: CROWN IS NOT PROVIDED WITH KITS**

CROWN PROFILE

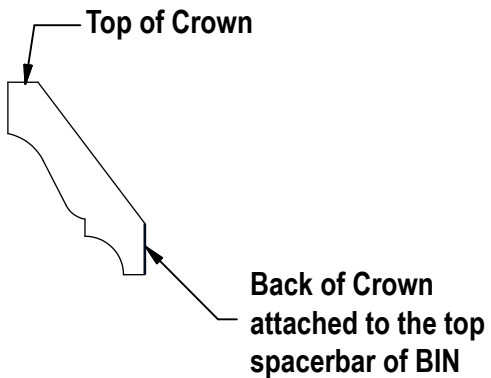

SIDE VIEW OF CROWN ATTACHED TO TOP SPACERBAR OF BIN

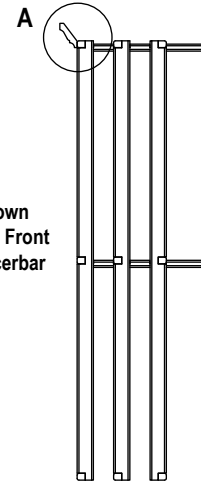
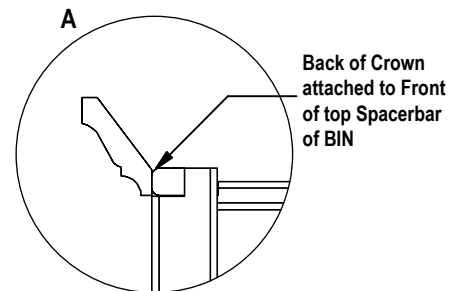

B

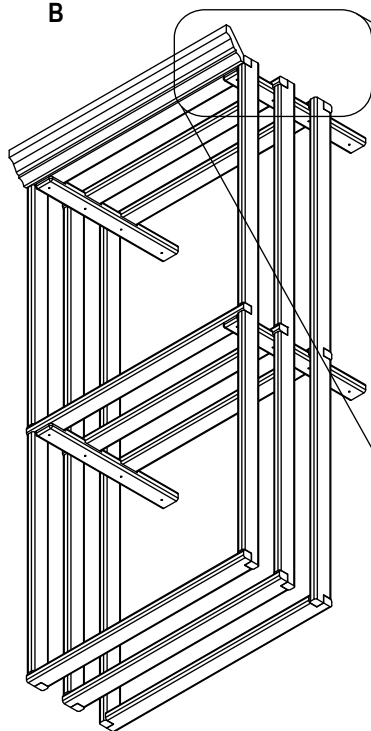

VIEW OF BIN FROM UNDERNEATH TO SHOW FACES OF CROWN FLUSHED WITH BIN

Side of Crown attached to the side of the upright of Bin

B

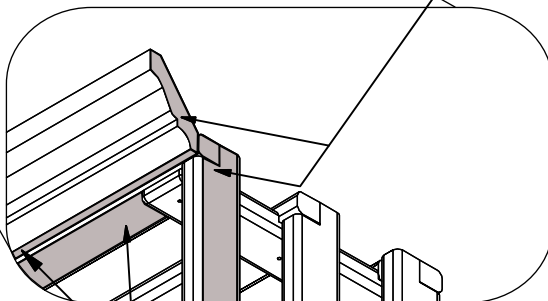

Bottom of Crown Flushed to the Bottom of the top Spacerbar of Bin

CROWN ATTACHED TO BIN

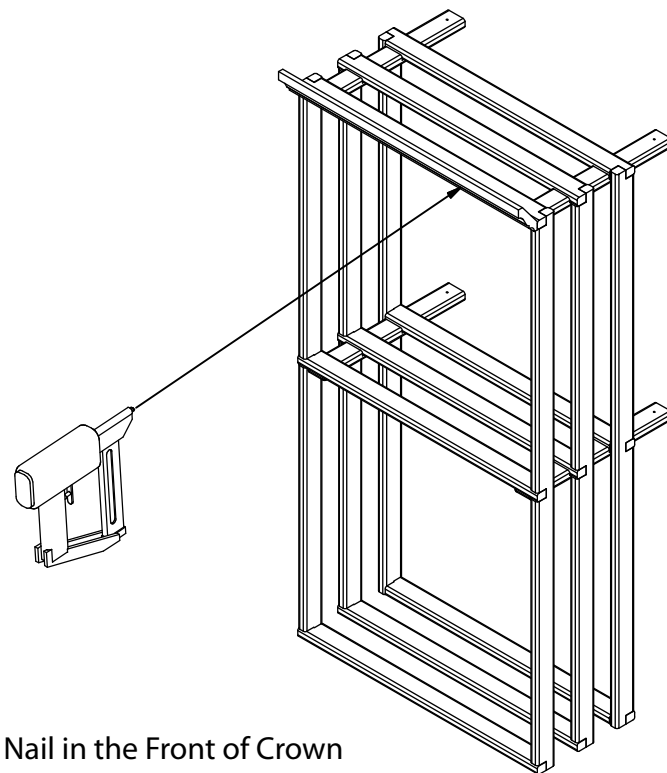

Nail in the Front of Crown

1-2 NAILS PER LOCATION

STEP
9

SLIDE BIN DIVIDERS INTO PLACE

Dividers slid into place

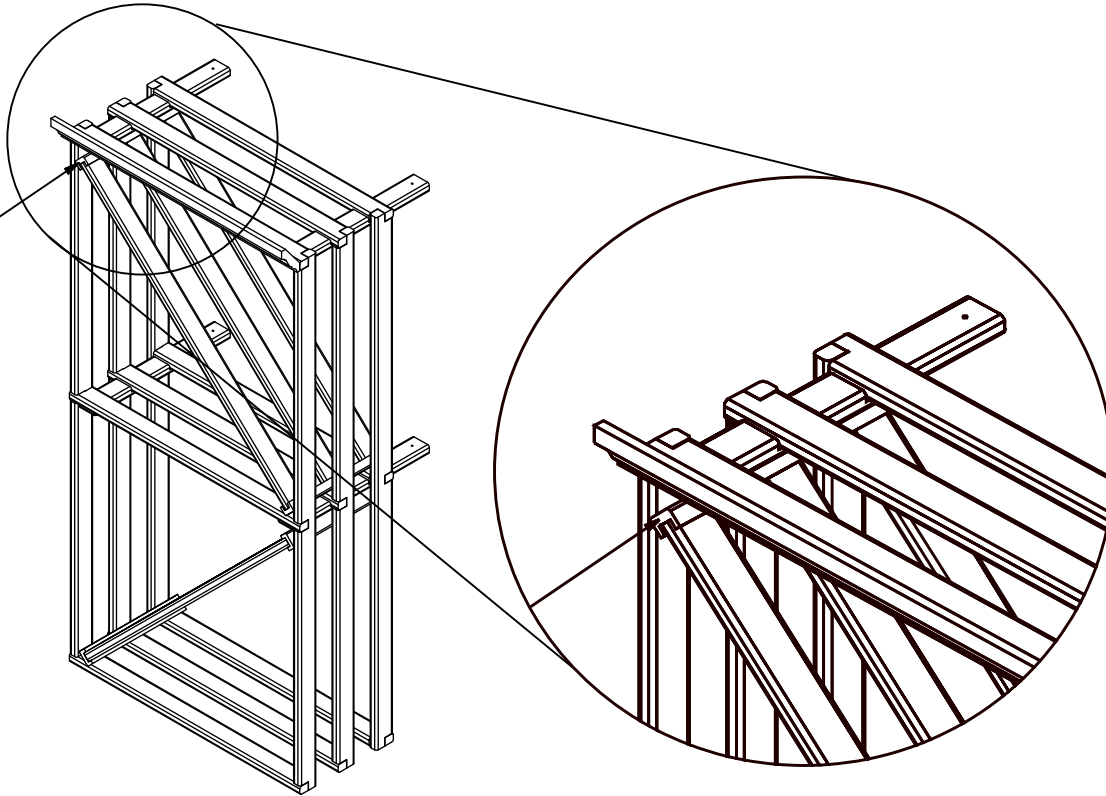

FRONT VIEW OF BINS WITH DIVIDERS

