

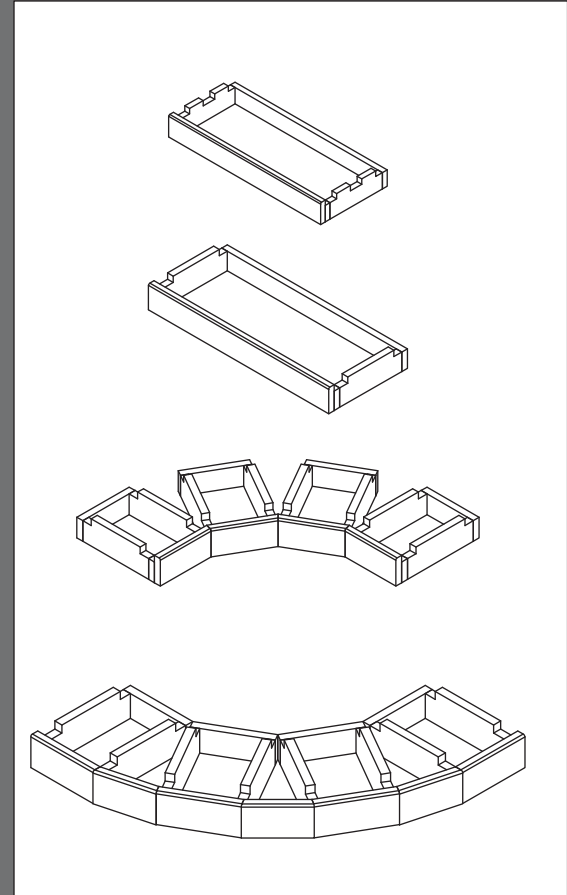

ASSEMBLY INSTRUCTIONS



FOR KIT RACKS:

- BASE MOULD BIN 16, 24, 32
- BASE MOULD IB 16, 32
- BASE MOULD CORNER (INSIDE)
- BASE MOULD CORNER (OUTSIDE)

INTRODUCTION

Thank you for purchasing a **KIT RACK** by **Genuine Cellars**.
The following instructions will help you assemble kits:

- BASE MOULD BIN 16
- BASE MOULD IB 16
- BASE MOULD CORNER (inside)
- BASE MOULD CORNER (outside)

The same instructions may be used to assemble kits:

- BASE MOULD BIN 24
- BASE MOULD BIN 32
- BASE MOULD IB 32

Please study the instructions carefully prior to starting the assembly.

BASE MOULD BIN 16

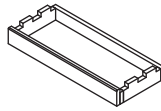

BASE MOULD IB 16

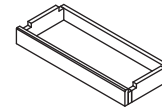

BASE MOULD CORNER (inside)

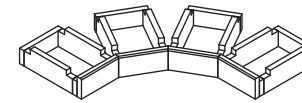

BASE MOULD BIN 24

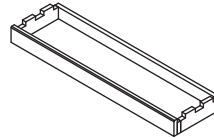

BASE MOULD IB 32

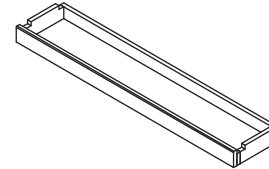

BASE MOULD CORNER (outside)

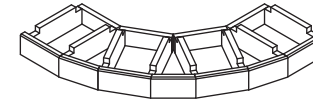

BASE MOULD BIN 32

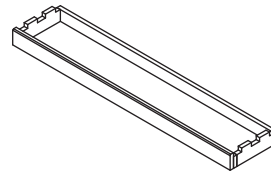

COMPONENTS

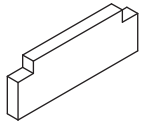

IB BASE SIDE
With 2 notches

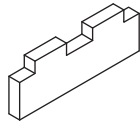

BIN BASE SIDE
With 3 notches

BASE BLOCK

- Sizes:
- 4 3/8"
 - 16"
 - 24"
 - 32"

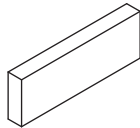

BASE MOULDING

- Sizes:
- 16"
 - 24"
 - 32"

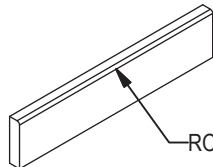

ROUNDED EDGE

NOTE:

Base moulding for the BASE MOULD CORNERS have mitered ends to facilitate assembly of the curved corners.

KIT NUMBER	COMPONENT			
	IB BASE SIDE	BIN BASE SIDE	BASE BLOCK	BASE MOULDING
BASE MOULD IB 16	2	N/A	2	1
BASE MOULD IB 32	2	N/A	2	1
BASE MOULD BIN 16	N/A	2	2	1
BASE MOULD BIN 24	N/A	2	2	1
BASE MOULD BIN 32	N/A	2	2	1
BASE MOULD CORNER (Outside)	2	N/A	8	7
BASE MOULD CORNER (Inside)	2	N/A	8	4

HARDWARE

The following hardware is included in all kits:

**18 GAUGE BRAD NAILS
(3 SLEEVES)**

TOOLS REQUIRED

The following tools are required
(NOT INCLUDED):

NAIL GUN
(with appropriate air compressor
or electric nailer)
18 gauge brand nails (supplied)

**WOOD
GLUE**

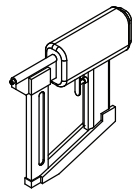

IMPORTANT!

Always follow the manufacturer's instructions on how to use the nail gun to prevent injury. Genuine Cellars is not liable for any injury incurred by any power or hand tool used to assemble the kit.

ASSEMBLY - BASE MOULD BIN & IB

STEP 1

APPLY GLUE TO THE ENDS OF THE BASE

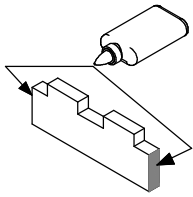

BIN BASE SIDE

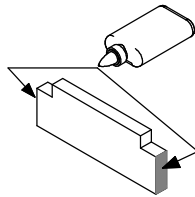

IB BASE SIDE

*Apply enough glue so that it will not run when the pieces are nailed together

STEP 2

NAIL BASE BLOCKS TO BASE SIDES

3 NAILS PER CONNECTION

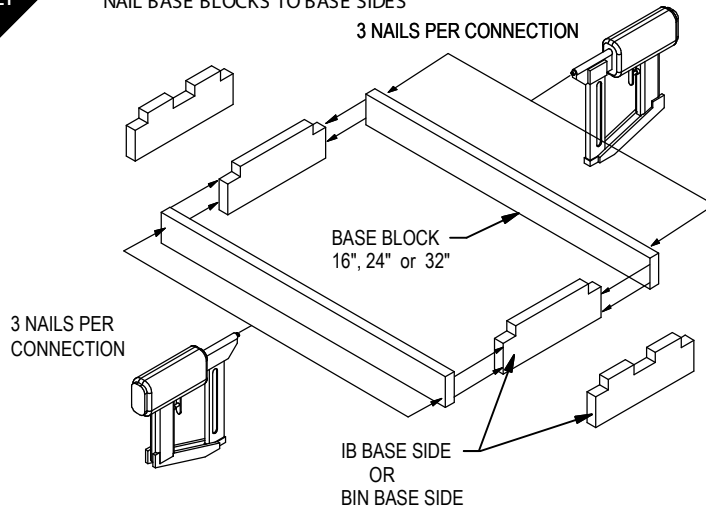

STEP 4

ATTACHING BASE MOULD BIN TO BINS AND BASE MOULD IB TO IB RACKS

BIN 16 32

IB 16 32

NAIL IB RACK AND BIN TO BASE MOULD THROUGH THE FRONT AND REAR SPACER BARS

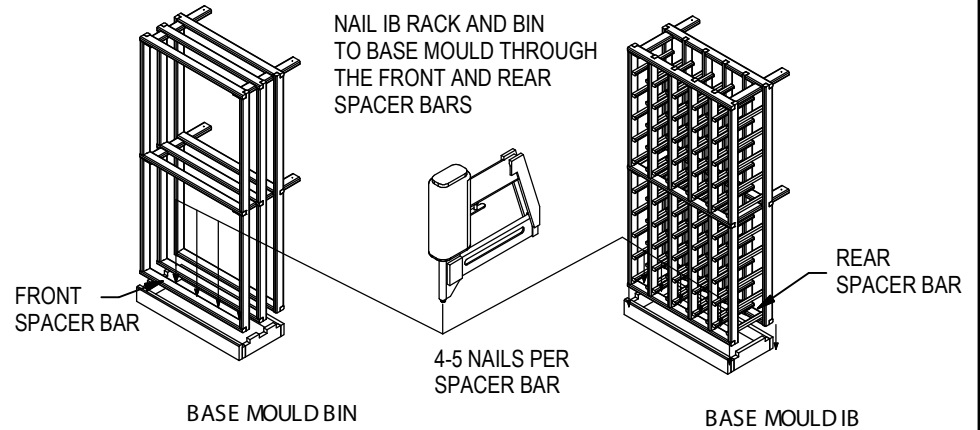

ASSEMBLY - BASE MOULD CORNER (Inside & Outside)

STEP 1

APPLY GLUE TO BASE SIDES

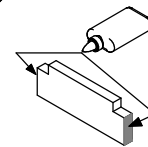

IB BASE SIDE

STEP 2

NAIL BASE BLOCKS TO BASE SIDES

APPLY GLUE TO THE ENDS OF THE BASE

3 NAILS PER CONNECTION

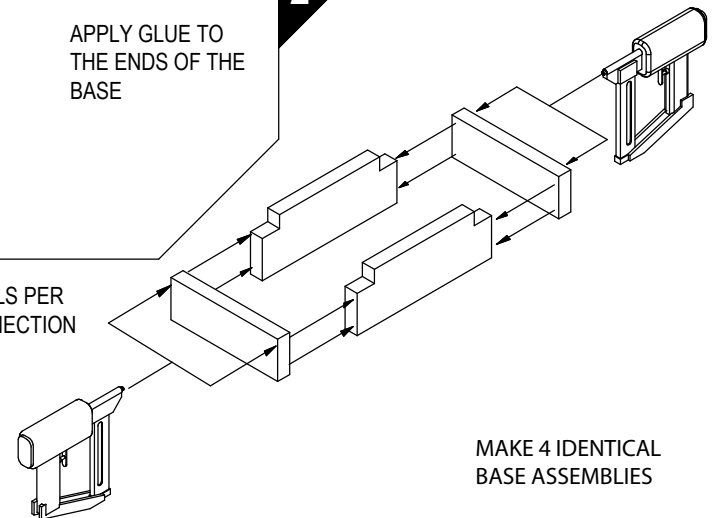

STEP 3

ATTACH BASE MOULD TO ASSEMBLY

4-5 NAILS

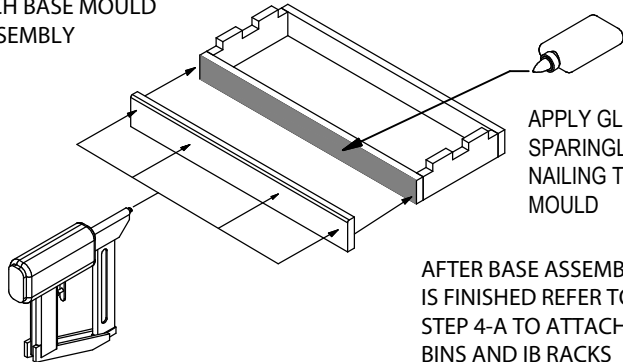

APPLY GLUE SPARINGLY BEFORE NAILING THE BASE MOULD

AFTER BASE ASSEMBLY IS FINISHED REFER TO STEP 4-A TO ATTACH TO BINS AND IB RACKS

STEP 3

ATTACH BASE MOULD TO BASE ASSEMBLY
(DESCRIBED SEPARATELY FOR EACH
INSIDE AND OUTSIDE CURVED CORNER)

A

BASE MOULD CORNER (INSIDE) ASSEMBLY

APPLY GLUE
SPARINGLY BEFORE
NAILING THE BASE
MOULD

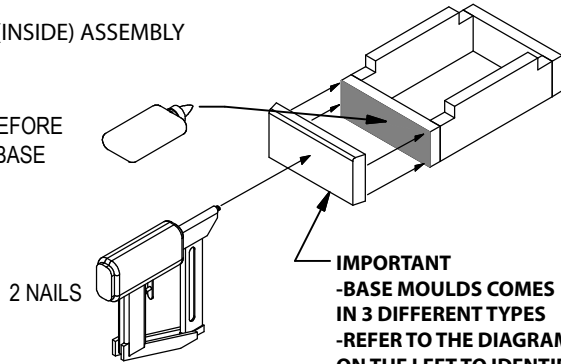

2 NAILS

IMPORTANT
-BASE MOULDS COMES
IN 3 DIFFERENT TYPES
-REFER TO THE DIAGRAM
ON THE LEFT TO IDENTIFY
EACH BASE MOULD
-ATTACH ONE OF THESE
TO EACH BASE ASSEMBLY

TOP VIEW

LEFT SIDE
BASE MOULD

RIGHT SIDE
BASE MOULD
MIDDLE
BASE MOULDS

ONCE BASE MOULDS ARE ATTACHED
REFER TO STEP 4-B FOR ATTACHING
BASE ASSEMBLY TO CURVE CORNER KIT

STEP 4

ATTACHING BASE MOULD CORNER TO
CURVED CORNER KIT (INSIDE & OUTSIDE)

CURVED CORNER
KIT (INSIDE)

REAR
SPACER BARS

FRONT
SPACER BARS

2-3 NAILS PER
SPACER BAR

NAIL CURVED CORNER
TO BASE MOULD THROUGH
THE FRONT AND REAR
SPACER BARS

STEP 3

BASE MOULD CORNER (OUTSIDE) ASSEMBLY

B

APPLY GLUE
SPARINGLY BEFORE
NAILING THE BASE
MOULD

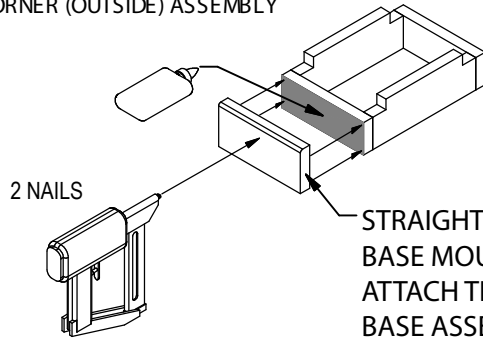

2 NAILS

STRAIGHT END
BASE MOULD
ATTACH THESE TO
BASE ASSEMBLY

TOP VIEW

ANGLED END
BASE MOULD
-DO NOT ATTACH THESE
BASE MOULDS UNTIL
THE WHOLE BASE
ASSEMBLY IS ATTACHED
TO THE CURVED
CORNER

ONCE BASE MOULDS ARE ATTACHED
TO BASE MOULD ASSEMBLY
REFER TO STEP 4-B FOR ATTACHING
BASE MOULD ASSEMBLY TO CURVE CORNER KIT

CURVED CORNER
KIT (OUTSIDE)

2-3 NAILS
PER SPACER BARS

FRONT
SPACER BARS

ATTACH THE INDIVIDUAL
BASE MOULD ASSEMBLIES
FIRST

2-3 NAILS
PER CONNECTION

NAIL ANGLED BASE MOULDS
TO THE BASE ASSEMBLY
AT AN ANGLE

