



# MIMOSA<sup>®</sup>

THE SIGNATURE COLLECTION



## OUTDOOR GAS AREA HEATER -DIRECTIONAL BLACK



- Provides warmth and ambiance for outdoor settings
- AGA Gas Certified

ITEM NO.  
0229110  
MADE IN  
CHINA

INFORMATION

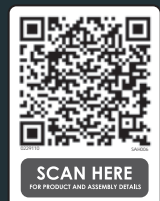

Important: Please retain these instructions for future use

# Gas Leak Test

Gas connections on the heater are leak tested at the factory prior to shipment. A complete gas tightness check must be performed due to possible mishandling in shipment or excessive pressure being applied to the heater gas connections.

1. Make a soap solution of one part liquid detergent and one part water.



Make sure the control knob on the heater is off and the gas valve on the cylinder is off before mixing the soapy solution.

2. Turn on the gas bottle.

3. Apply the soap solution to the gas connections using a soft bristle brush.

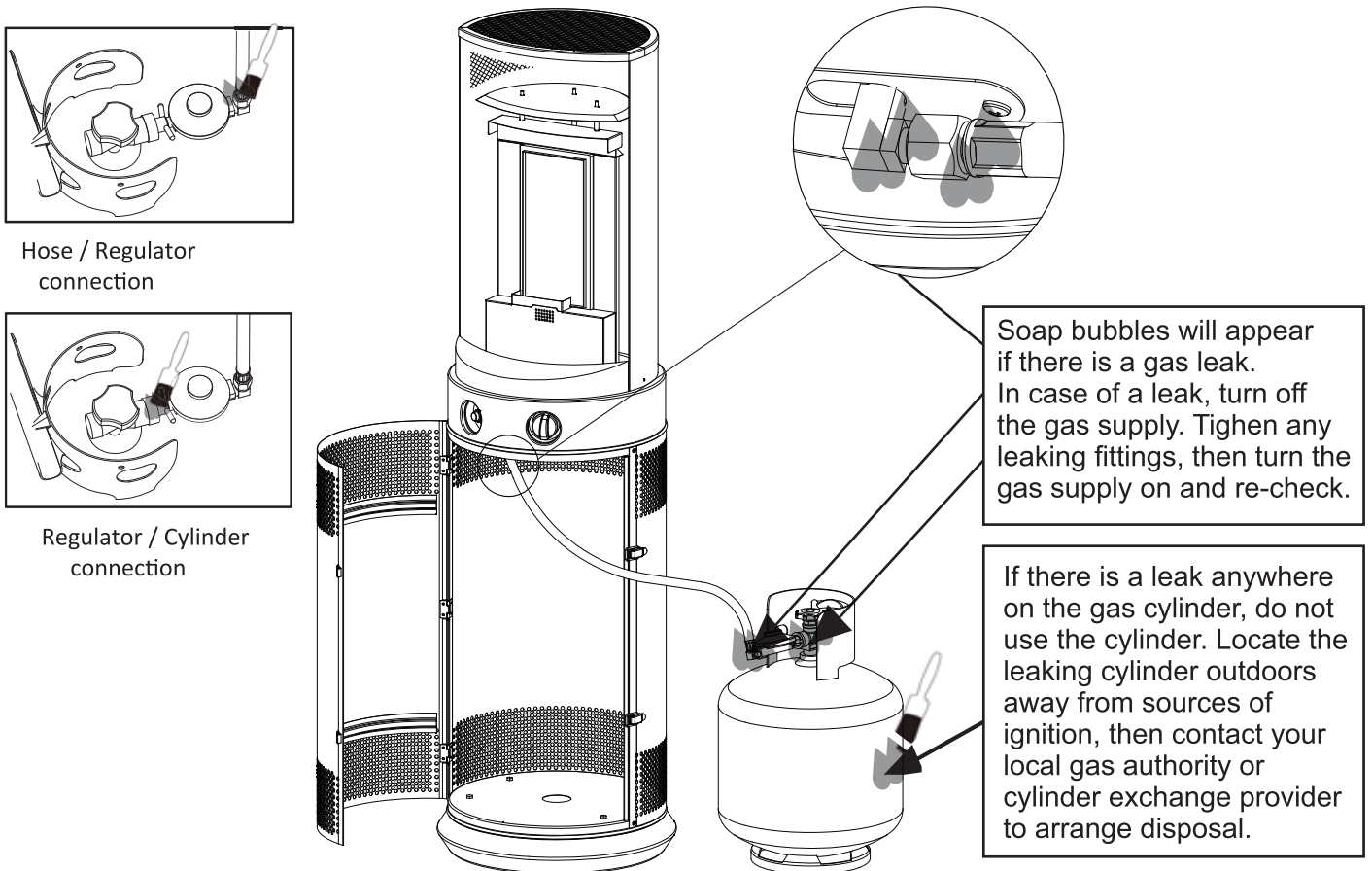

## Warning:

Do not operate the appliance until all gas leaks have been rectified.  
Never leak test while smoking.

# Table Of Contents

Caution.....	Page 1
Heater Stand and Location.....	Page 2
Gas Requirements.....	Page 5
Leakage Test.....	Page 5
Operation and Storage.....	Page 6
Cleaning and Care.....	Page 7
Parts and Specifications.....	Page 7
Assembly Parts and Procedures.....	Page 8
Assembly Steps.....	Page 9
Pilot Service.....	Page 10
Trouble Shooting.....	Page 11
Product Warranty.....	Page 12

# Caution

## PLEASE READ CAREFULLY THE FOLLOWING SAFETY GUIDELINES BEFORE OPERATION.

- This patio heater is not for commercial use.
- Do not use the patio heater for indoors, as it may cause personal injury or property damage.
- Do not place articles on or against this appliance
- Do not use or store flammable materials near this appliance
- Do not spray aerosols in the vicinity of this appliance while it is in operation
- This outdoor heater is not intended to be installed on recreational vehicles and/or boats.
- Repair should be done by a qualified service person.
- Improper installation, adjustment, alteration can cause personal injury or property damage.
- Do not attempt to alter the unit in any manner.
- Never replace or substitute the regulator with any regulator other than the factory-suggested replacement.
- Do not store or use petrol or other flammable vapors or liquids in the heater unit.
- The whole gas system, hose, regulator, pilot or burner should be inspected for leaks or damage before use, and at least annually by a qualified service person.
- All leak tests should be done with a soap solution. Never use an open flame to check for leaks.
- Do not use the heater until all connections have been leak tested.
- Turn off the gas valve immediately if smell of gas is detected.
- Do not transport heater while it's operating.
- Do not move the heater after it has been turned off until the temperature has cooled down.
- Keep the ventilation opening of the cylinder enclosure free and clear of debris.
- Do not paint the radiant screen, control panel or top canopy reflector.
- Control compartment, burner and circulation air passageways of the heater must be kept clean. More frequent cleaning may be required as necessary.
- The gas cylinder should be turned off when the heater is not in use.
- Check the heater immediately if any of the following occurs:
  - the heater does not reach temperature.
  - the burner makes popping noise during use ( a slight noise is normal when the burner is extinguished ).
  - smell of gas in conjunction with extreme yellow tipping of the burner flames.
- The regulator/hose assembly must be located out of pathways where people may trip over it or in area where the hose will not be subject to accidental damage.
- Any guard or other protective device removed for servicing the heater must be replaced before operating the heater.
- Adults and children should stay away from high temperature surface to avoid burns or clothing ignition.
- Children should be carefully supervised when they are in the area of the heater.
- Clothing or other flammable materials should not be hung on the heater or placed on or near the heater.
- This appliance shall not be installed or used indoors
- If there is any evidence of excessive abrasion or wear, Or if the hose assembly is damaged do not operate the appliance until a replacement hose assembly has been obtained from your authorized service provider Ensure that the replacement hose assembly is as specified by the manufacturer.
- Due to radiant heat Certain materials or items may be seriously damaged if stored under or near this appliance while it is in operation.
- Remove any packaging/transit protection prior to operating this appliance.
- **This heater must be protected from rain.**
- **DO NOT MODIFY THIS APPLIANCE**
- **DO NOT USE AN ADAPTOR AT THE CYLINDER CONNECTION**

# Heater Stand and Location

- The heater is for outdoor use only. Always ensure that adequate fresh air ventilation is provided.
- Always maintain proper clearance to combustible materials, i.e. top 480mm and sides 480mm minimum.
- **Heater must be placed on level firm ground.**
- Never operate heater in an explosive atmosphere like in areas where petrol or other flammable liquids or vapors are stored.
- This appliance shall only be used in an above ground open-air situation with natural ventilation, without stagnant areas, where gas leakage and products of combustion are rapidly dispersed by wind and natural convection.
- This appliance shall be used only in an outdoor area and shall not be used in a building, garage or any other enclosed area unless the enclosure meets the requirements outlined in this instruction manual.
- **Any enclosure in which the appliance is used shall comply with one of the following:**

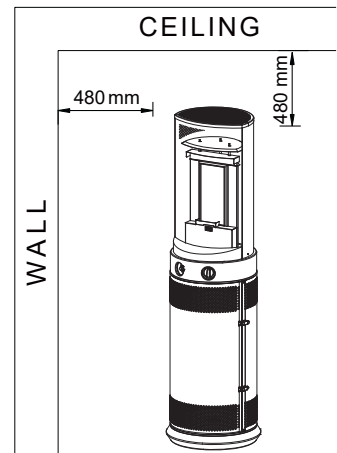

**An enclosure with walls on all sides, but at least one permanent opening at ground level and no overhead cover.**

**Within a partial enclosure that includes an overhead cover and no more than two walls.**

**Within a partial enclosure that includes an overhead cover and more than two walls, the following shall apply:**

- at least 25% of the total wall area is completely open, and
- at least 30% of the remaining wall area is open and unrestricted.

**In the case of balconies, at least 20% of the total wall area shall be and remain open and unrestricted.**

## How to locate the heater with Zero Clearance

This heater can be located with zero clearance provided the heater does not transfer excessive heat to the surrounding walls. Ensure to locate your heater as described below to prevent heat damage or fire on surrounding structures.

**Corner location.**  
Zero clearance  
to rear corner.

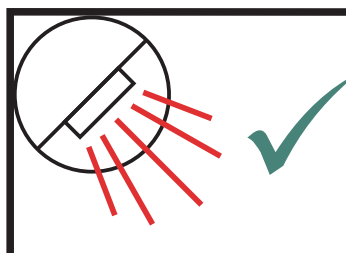

**Wall location.**  
Zero Clearance  
to rear wall.

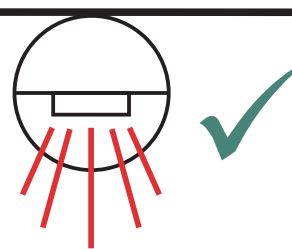

**Incorrect location.**  
Don't face the heater  
towards a corner or wall.

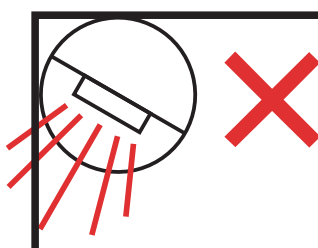

**Incorrect location.**  
Don't face the heater so  
heat is projected along a wall.

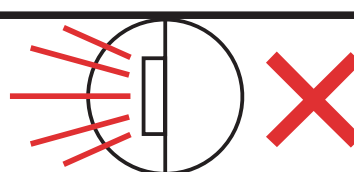

## DIAGRAMMATICAL REPRESENTATIONS OF OUTDOOR AREAS

(Informative)

The following figures are diagrammatical representations of outdoor areas as described above. Rectangular areas have been used in these figures - the same principles apply to any other shaped area.

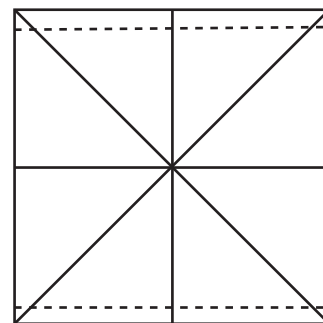
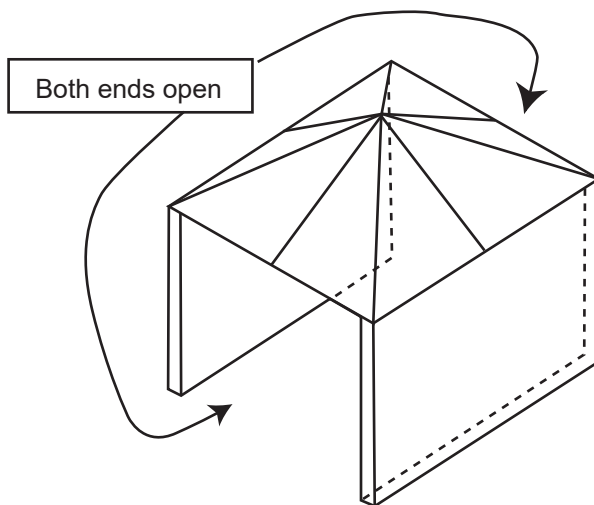
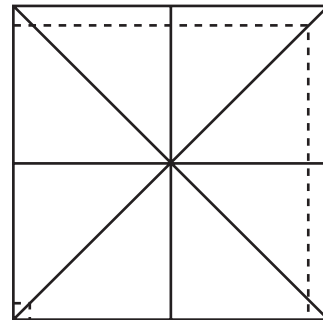
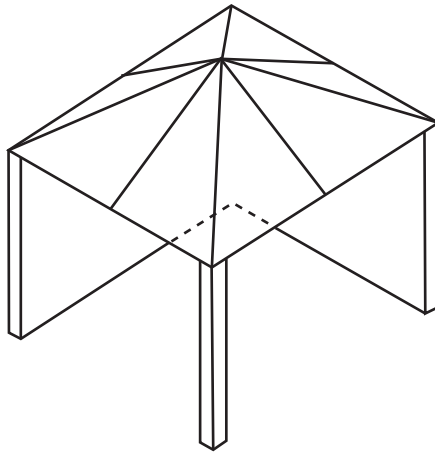
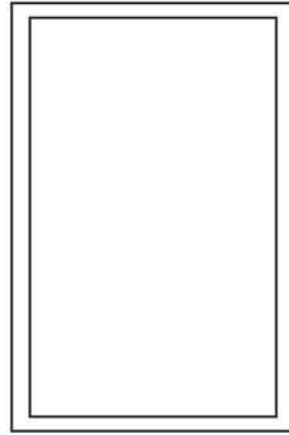
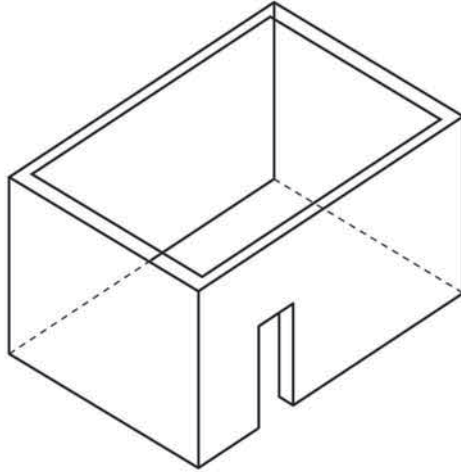

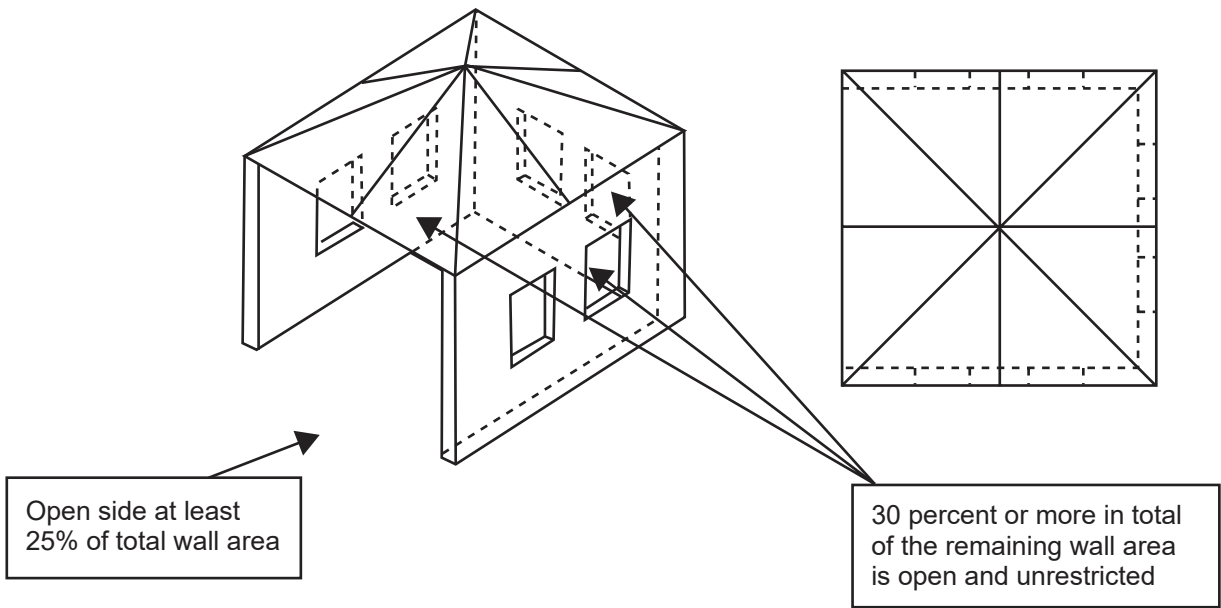
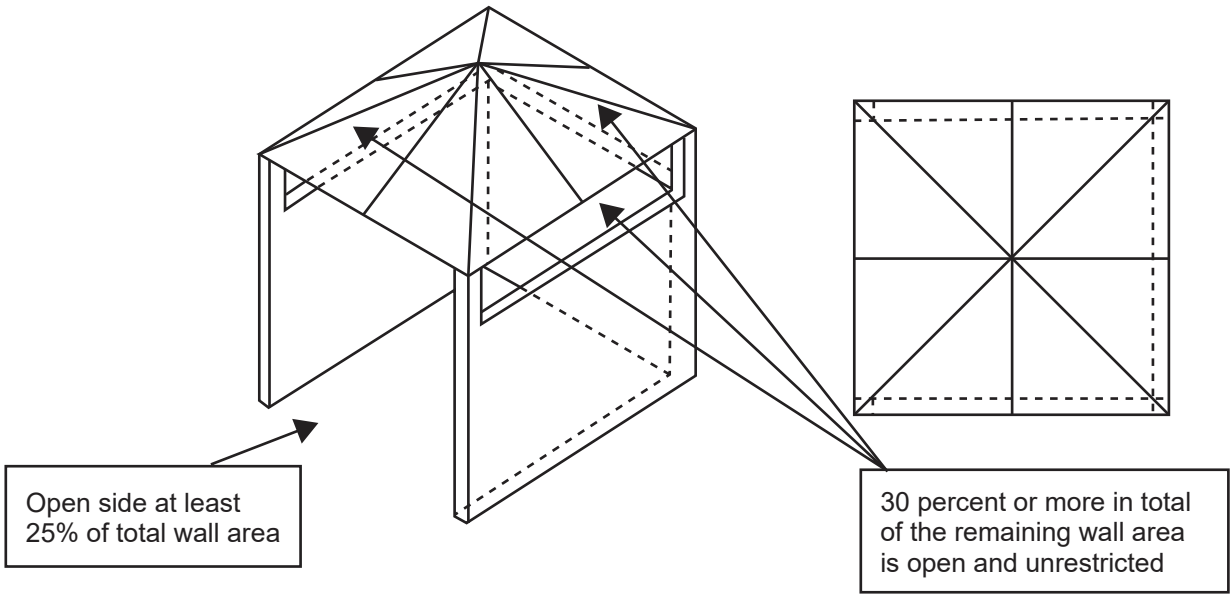

# Gas Requirements

- Refer to the gas type label for confirmation of the gas type to be used with your appliance.
- Use only the pressure regulator and hose assembly supplied with this appliance.
- A dented, rusted or damaged gas cylinder may be hazardous and should be checked by your cylinder supplier. Never use a gas cylinder with a damaged valve connection.
- Never connect an unregulated gas cylinder to the heater.
- This appliance is NOT suitable for use with a fixed gas supply system. Use ONLY a 9kg gas cylinder.

# Leakage Test

- Gas connections on the heater are leak tested at the factory prior to shipment. A complete gas tightness check must be performed due to possible mishandling in shipment or excessive pressure being applied to the heater.
- Make a soap solution of one part liquid detergent and one part water.
- The soap solution can be applied with a spray bottle, brush or rag. Soap bubbles will appear in case of a leak.
- The heater must be checked with a full cylinder.
- Make sure the safety control valve is in the OFF position.
- Apply the soap solution to the gas connections.
- Turn the gas supply ON.
- In case of a leak, turn off the gas supply. Tighten any leaking fittings, then turn the gas supply on and re-check.
- Do not operate the appliance until all gas leaks have been rectified.
- Never leak test while smoking.



# Operation and Storage

## TO TURN ON THE HEATER

1. The pilot burner is a very small burner below the large heater burner.

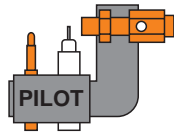

2. To light the heater, turn the control knob to the pilot position and keep the control knob depressed so gas can flow to the pilot burner. This can take 1 to 2 minutes.

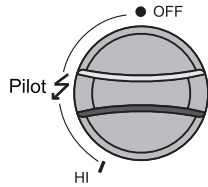

3. Activate the igniter button repeatedly until you see the blue flame of the pilot through the viewing holes. The pilot flame can be difficult to see in direct sunlight.



4. Keep the control knob depressed for 30 seconds after the pilot burner is alight to establish the pilot flame, then release the knob and check the pilot remains alight.

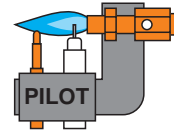

5. Turn knob to the HI position to light the heater burner.

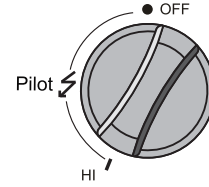

6. If the pilot will not stay alight, reset the tip over switch by tilting the heater 45°, then return the heater to upright.

Lighting Tip: If the Pilot flame drops out repeatedly while lighting, try turning the knob to HI immediately after the pilot has ignited.

## TO TURN OFF THE HEATER

1. Turn the variable control knob to PILOT position.
2. Press and turn the variable control knob to OFF position.
3. Turn off the valve on the gas supply cylinder completely.

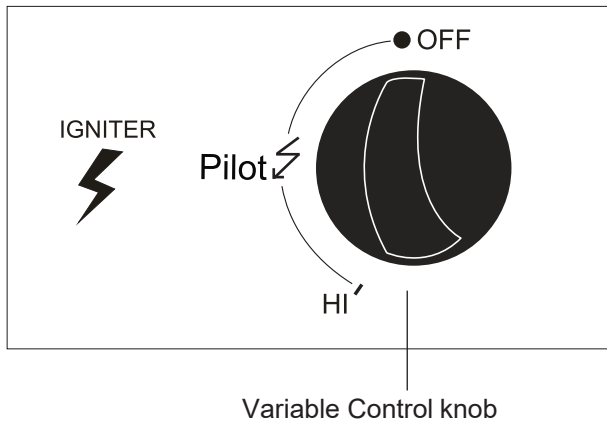

**THE GUARD IS FITTED TO THIS APPLIANCE TO REDUCE THE RISK OF FIRE OR INJURY FROM BURNS AND NO PART OF IT SHOULD BE REMOVED.**

**WHEN LIGHTING HEATER, KEEP FACE AWAY FROM EMITTER GUARD.**

## **Storage**

1. Always close the gas valve of the gas cylinder after use or in case of a disturbance.
2. Disconnect the regulator from the gas cylinder valve.
3. Check the tightness of the gas valve for damage. If you suspect damage, have it changed by your gas dealer.
4. Never store gas cylinders underground or in places without adequate air ventilation.
5. There is no limitation on the storage of appliances indoors provided that the cylinder is removed from the appliance; and
6. Storage of an appliance indoors with the cylinder attached is only permitted if the size of the cylinder complies with AS/NZS 1596; otherwise cylinders must be stored outdoors in a well-ventilated area and out of reach of children.

# Cleaning and Care

- Wipe off powder coated surfaces with soft, moist rag. Do not clean heater with cleaners that are combustible or corrosive.
- Remove debris from the burner to keep it clean and safe for use.
- Cover the burner unit with the optional protective cover when the heater is not in use.

# Parts and Specifications

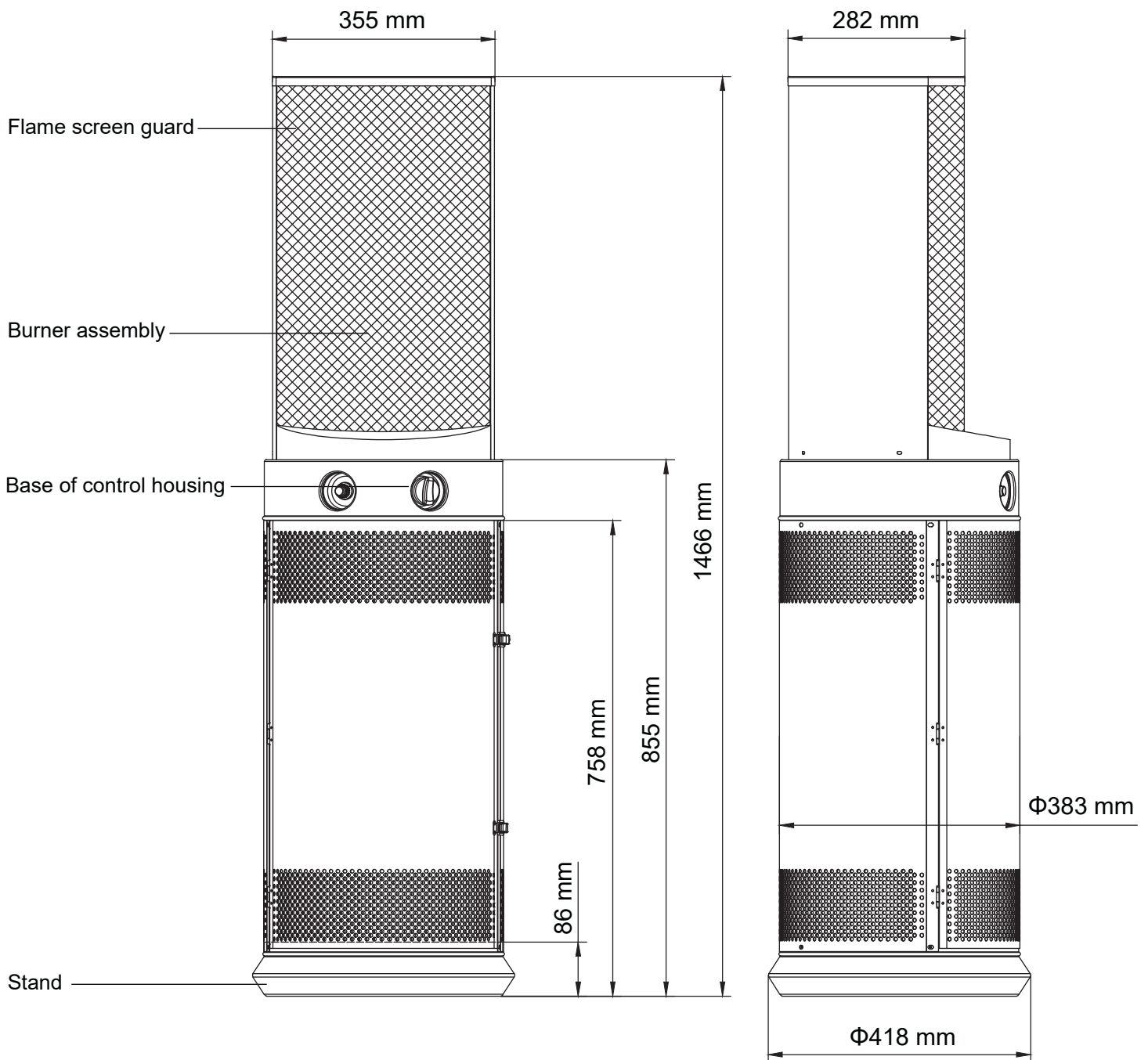

### A. Construction and characteristics

- Transportable terrace/garden heater
- Gas hose connections with screw caps
- Stainless steel flame screen
- Heat emission from reflector

### B. Specifications

- For outdoor use only
- Factory set for use with Propane gas.
- Nominal gas consumption at high setting: Propane 12.7MJ/h
- Weight: Metal w/ powder coating 13.0 kgs.
- Height: 146.6 cm including stand
- With AGA, CE and CSA certificates
- Gas inlet fitting: 1/4' inverted flare type with internal O-ring seal.

### C. Table of openings

Model	Gas inlet pressure	Main opening
Propane	2.75KPa	1.05 mm

## Assembly Parts and Procedures

#### Tools needed:

- Open end wrench 10 & 13 mm
- Adjustable opening wrench (2) 20 cm long
- Slip joint pliers 23 cm long
- Philips screwdriver w/ medium blade
- Spray bottle of soap solution for leakage test

#### Parts supplied:

- 4pcs Self Taping Screws for burner head and tank housing body
- Hose and regulator assembly

# Assembly Steps

## STEP 1

Open the door, use 4pcs Self Taping Screws to join the burner head and tank housing body.

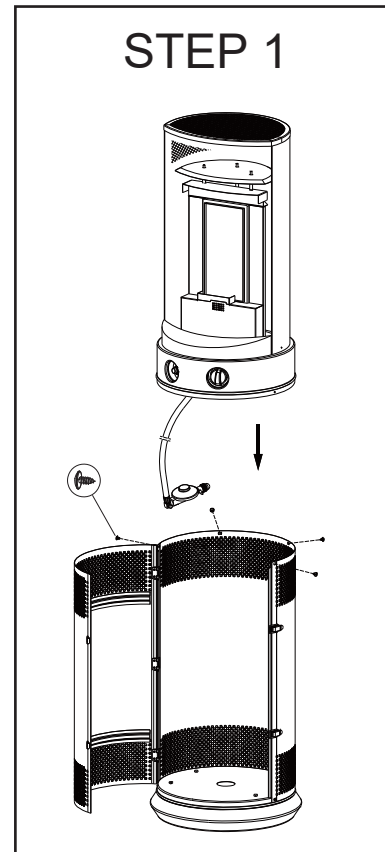

## STEP 2

2-1. Unscrew the igniter button, then install the battery and tighten igniter button.

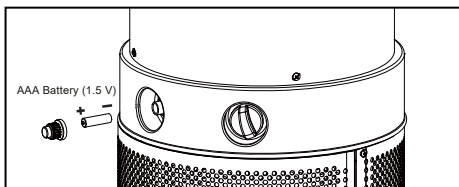

2-2. Open the door of tank housing.

2-3. Attach the regulator to the gas cylinder and tighten with wrench if fitted with a nut, or tighten by hand if fitted with a hand wheel.

2-4. Then leak test the gas inlet and gas cylinder connections as explained in the section, GAS LEAK TEST.

2-5. Thoroughly check the gas connections for gas leakage. If you identify a leak and it cannot be stopped, disconnect the LPG cylinder and do not use the heater until the leak has been fixed.

2-6. Put the gas cylinder into the tank housing, then close the door.

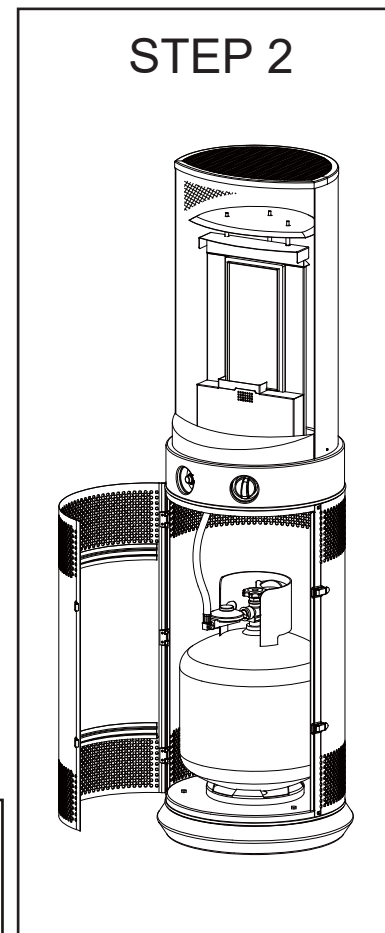

**Note:** The ignitor is powered by a small battery, if the pilot can't be lighted, the problem may be the battery which is exhausted. Please replace the battery(DC 1.5V).

# Pilot Service

The pilot burner should produce a small blue flame. If your pilot flame is very large or orange or the pilot flame comes out of the side holes, you need to service your pilot burner.

To service the pilot burner, remove the safety guard then remove the windshields to access the pilot. Then insert a pipe cleaner into the air holes at the base of the pilot tube, and in the pilot burner tube as shown below to clear spider webs or nests.

Blow air through the pilot burner tube and through the air holes at the base of the pilot tube to clear the pilot burner of dead moths or bugs.

Don't poke wire or drills into the pilot burner to prevent damage to the precise gas jet inside the pilot tube.

A pilot blockage will prevent normal operation of your heater so regularly check your pilot.

In normal operation, the pilot flame touches the brass probe. If you see any black soot build up on the brass probe, wipe it off with a tissue.

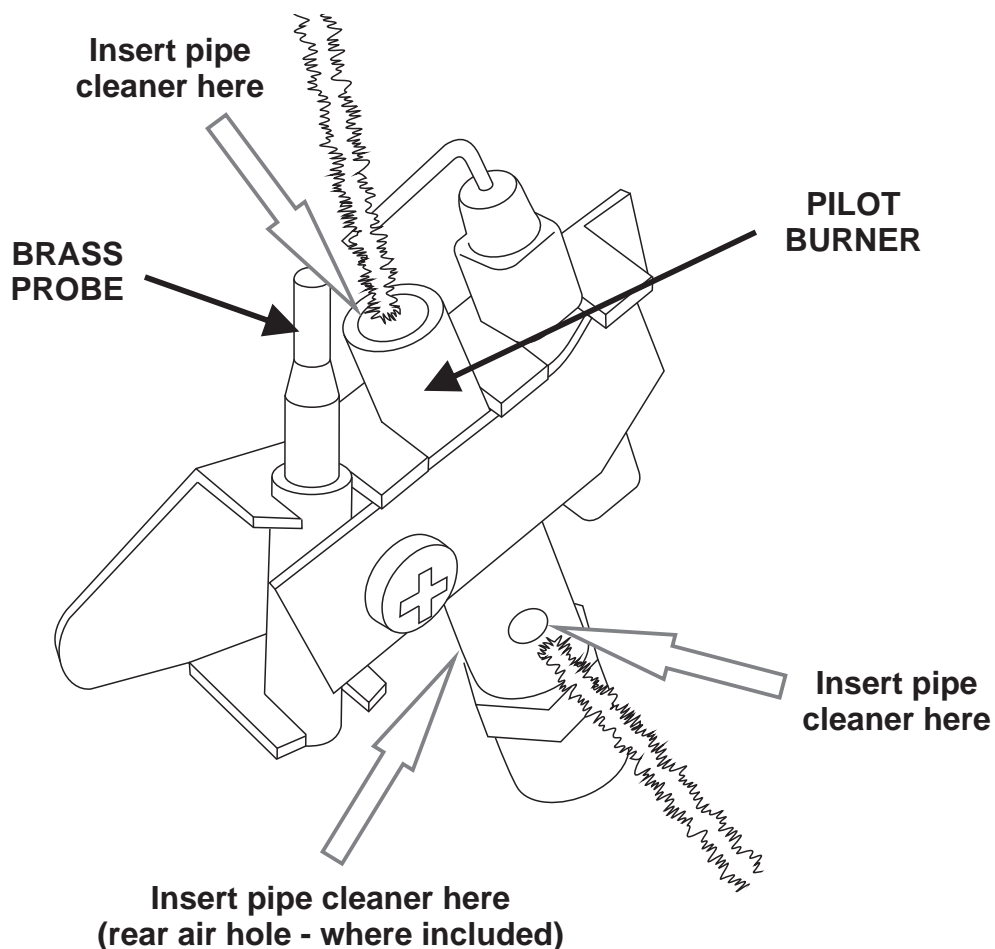

The Illustration above is generic. The pilot burner fitted to your heater may have a slightly different appearance however, the servicing procedure is exactly the same as described above.

# Trouble Shooting

<b>Problem</b>	<b>Possible cause</b>	<b>Solution</b> (If these do not solve the problem contact a service technician).	<b>What ONLY an authorised service technician can do</b>
Pilot will not light	LPG Cylinder valve may be OFF  LPG Cylinder may be empty  Air has not been fully removed from the pilot gas supply line  Blockage in Pilot burner  Thermocouple failure  Loose gas connections causing a drop in supply pressure  Attempting to use the heater in an enclosed area.	Check regulator is correctly connected to the LPG cylinder, then open the LPG cylinder valve.  Arrange refilling or exchange of your LPG cylinder  Follow the lighting steps again. Turn knob to PILOT, then press and hold the knob in for at least one minute.  Service the pilot burner as shown in this manual  The pilot flame heats the thermocouple and this allows gas to flow to the pilot. If the thermocouple or its connections fail, the thermocouple assembly must be replaced.  Follow the leak check instructions in this manual to check the connections from the LPG cylinder to regulator, check all along hose for leaks and check the hose connection to the heater.  As mandated by the Australian Government, this heater is fitted with an oxygen sensing pilot burner which will not operate in a low oxygen environment or indoors. Only use this heater in an outdoor area.	Refill the LPG cylinder          Disassemble then re-assemble all the internal gas connections.
Burner will not stay on	LPG Cylinder may be empty  Loose gas connections causing a drop in supply pressure	Arrange refilling or exchange of your LPG cylinder  Follow the leak check instructions in this manual to check the connections from the LPG cylinder to regulator, check all along hose for leaks and check the hose connection to the heater.	Refill the LPG cylinder   Disassemble then re-assemble all the internal gas connections.
Burner flame is low	Supply hose is bent or twisted	Straighten hose and perform leak test on hose	
Thick Black Smoke or Carbon Build Up	Blockage in burner	Turn off the heater and let it cool.	Remove blockage and clear burner inside and outside
Gas leak at inlet connection	Damaged or deteriorated O-ring seal	Fit a new O-ring	

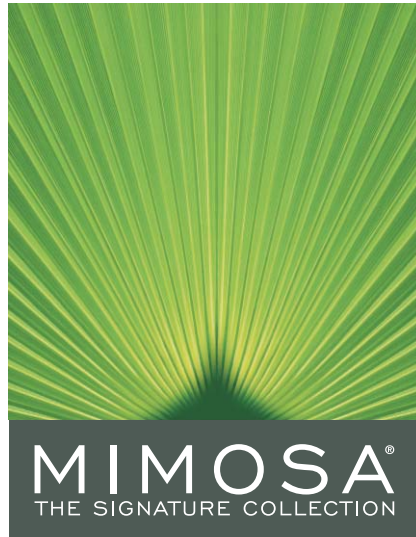

---

## PRODUCT WARRANTY

---

Any claim under this warranty must be made within 12 Months of the date of purchase of the product. To make a claim under the warranty, take the product (with proof of purchase) to any Bunnings store (see [www.bunnings.com.au](http://www.bunnings.com.au) or [bunnings.co.nz](http://bunnings.co.nz) for store locations)

Bunnings Group Ltd bears reasonable, direct, expenses of claiming under the warranty. You may submit details and proof to our store for consideration.

The warranty covers manufacturer defects in materials, workmanship and finish under normal use.

This warranty is provided in addition to other rights and remedies you may have under law: our goods come with guarantees which cannot be excluded under the Australian Consumer Law or Consumer Guarantees Act 1993 (NZ). You are entitled to replacement or refund for a major failure and to compensation for other reasonably foreseeable loss or damage. You are also entitled to have the goods repaired or replaced if the goods fail to be of acceptable quality and the failure does not amount to a major failure.

The warranty excludes damage resulting from product misuse or product neglect. The warranty covers domestic use only and does not apply to commercial applications.

This warranty is given by Bunnings Group Limited ABN 26 008 672 179, Botanicca 3 Level 2 East Tower 570 Swan Street, Burnley, VIC 312, e-mail:

[CustomerSupport@bunnings.com.au](mailto:CustomerSupport@bunnings.com.au)

Or call our Customer Support Team – Ph.1800 797 586

This warranty is given by Bunnings NZ Limited: Postal address: PO Box 14436, Panmure, Auckland 1741,

e-mail: [OnlineEnquiries@bunnings.co.nz](mailto:OnlineEnquiries@bunnings.co.nz) Or call our Customer Support Team – [Ph.1800 797 586](tel:1800797586)